

Features and Benefits

- Small package (SOIC20)
- Short-circuit protection
- Diagnostic features
- Current limitation
- Low-power consumption
- Over-temperature protection
- Direct micro controller compatible
- Integrated free wheel diodes

Applications

- Automotive climate Control
- Dashboard
- Industrial Actuator control

Ordering Information

Part No.	Temperature Suffix	Package Code	Option code
MLX10410	E (-40°C to 85°C)	DF (SOIC-20)	CA

Functional Diagram

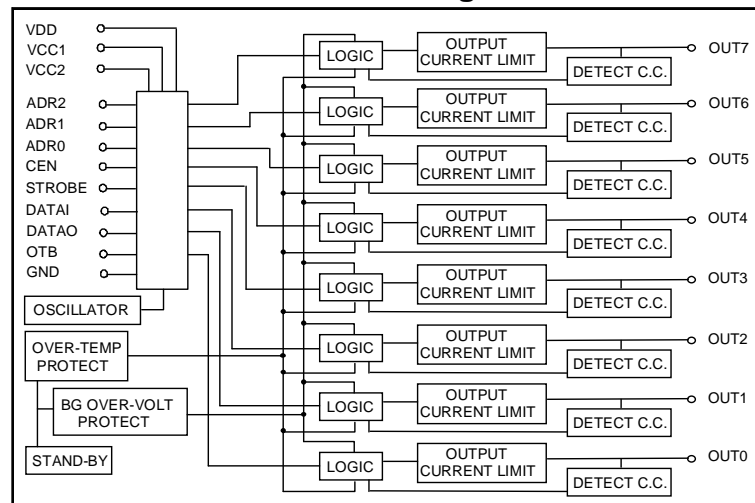

Figure 1

Description

The 10410 is a high-side driver for automotive applications. It can drive small lamps, relays, coils etc. The output current can be up to 250mA per driver (current limit at minimum 250mA).

The IC will only react to commands on the bus if the CEN (chip enable) signal is high. The CEN signal has nothing to do with the power down mode, the IC will react to the micro controller commands if CEN is high.

In order to switch a particular output, it is necessary to apply its address on the 3 bit bus and the data on the input DATAI. A high level on STROBE will latch the data and switch the output. When the IC is in active mode and CEN is high, the logic level of the addressed output will be available on the pin DATAO.

When all 8 outputs are inactive (latched value is low) the circuit automatically switches to power down mode.

Diagnostic mode: when the DATAI is low and the STROBE is high, a 50K pull up to VCC is switched on, on the corresponding output channel (addressed by ADR2, ADR1, ADR0) to see whether there is a load connected. The logic level of the output can be observed on the pin DATAO. In this way, it is possible to scan all the outputs for an open circuit.

When the IC is in active mode, then there is an over-temperature sensor that monitors the temperature of the IC. If the die temperature goes above 165°C, all outputs are switched off and the output OTB will go low. As soon as the temperature decreases below 125°C all outputs are switched back to their previous state.

The outputs are short-circuit proof against GND and VCC. When an output is shorted to GND, the current is limited and, after a delay of typically 20ms, the output is switched off and the output OTB goes low. A delay is used to guarantee that the output does not detect a short circuit when a normal lamp is driven. The latched value of the output is set to 0. A rising edge on CEN will set OTB back to 1. When an output is shorted to a supply larger than VCC+100mV, the output driver bulk is immediately disconnect from VCC, and after a delay of typically 20ms, the output is switched off and the output OTB goes low. The latched value of the output is set to 0. A rising edge on CEN will set OTB back to 1

There is an over-voltage shut off that switches all the outputs off when the VCC voltage is above 18V for at least 1ms. When an over-voltage occurs, CEN being low, DATAO pin will go low. The outputs will come on again as soon as the voltage decreases below 18V. The status of all 8 outputs stays latched.

Every output stage is protected with a free wheel diode both to ground and to VCC.

Table 1

Active mode			Description	DATA O	OTB
CEN	STROBE	DATA I			
0	0	0	Chip Disabled	0 Over-voltage	0 Over-temperature OR Short-circuit to GND
0	0	1		1 No Over-voltage	
0	1	0			
0	1	1			
1	0	0	No Command	Addressed output logic level	1 No Over-temperature
1	0	1	No Command		
1	1	0	Addressed output turned OFF (Diagnostic mode)	0 Load	
				1 No Load	
1	1	1	Addressed output turned ON	Addressed output logic level (always 1)	

ABSOLUTE MAXIMUM RATINGS

VCC	-0.3 to 40V
VDD	-0.3 to 5.5V
Maximum Output Voltage	-0.3V to VCC+0.3V
Maximum Output Current	±550mA
Maximum Free-Wheel Diodes Current	±250mA
Die Temperature	+170°C
Thermal Resistance Package	85°K/W
Storage Temperature	-55 °C to 125°C
ESD Protection all pins (human body model)	2KV

DYNAMIC CHARACTERISTICS

Characteristics	Description	Limits			
		Min	Typ	Max	Units
t_{sw}	STROBE pulse width	1.0			us
t_{sds}	DATA1 to STROBE setup time	0.1			us
t_{hds}	DATA1 to STROBE hold time	0.1			us
t_{scs}	CEN to STROBE setup time	0.1			us
t_{shs}	CEN to STROBE hold time	0.1			us
t_{dso}	STROBE to OUTPUT delay (R_{on} reached 20% of nominal value)			10	us
t_{dov}	Delay between Over voltage detection and outputs switched off	0.5	1.0	2.0	ms
t_{dso}	Delay between short circuit detection and output switched off	12	20	40	ms
t_{rov}	Recovery time from an over voltage detection			10	us

Electrical Characteristics

Following characteristics are valid over the temperature range from -40°C to $+85^{\circ}\text{C}$ unless otherwise specified.

Characteristics	Test Conditions	Limits			
		Min	Typ	Max	Units
Supply voltage VDD		4.5	5.0	5.5	V
Supply voltage VCC		4.5		25	V
Supply current Iccs	all outputs switched off			200	μA
Supply current Icca	all outputs on and no load			1000	μA
Supply current Icci	VCC=12V, one output on and no load			200	μA
Supply current Iccm	VCC=12V, one output on, no load, per supplementary output on			25	μA
Supply current Idds	all outputs switched off			100	μA
Supply current Idda	all outputs on and no load			500	μA
Supply current Iddi	one output on and no load			150	μA
Input threshold ADR2, ADR1, ADR0, DATAI, STROBE, CEN		$0.25 \cdot \text{VDD}$		$0.75 \cdot \text{VDD}$	V
Input hysteresis ADR2, ADR1, ADR0, DATAI, STROBE, CEN			$0.1 \cdot \text{VDD}$		V
Input current ADR2, ADR1, ADR0, DATAI, STROBE, CEN	V D D = 5 V a n d $0 < V_{in} < \text{VDD}$	-1.0	0.0	1.0	μA
V _{ol} DATAO, OTB	I _{out} =1mA			0.5	V
V _{oh} DATAO	I _{out} =1mA	VDD-0.5			V
I _{ohl} OTB	V _{out} =5V	-1.0		1.0	μA
Input threshold OUT7-0	diagnostic mode	$0.2 \cdot \text{VDD}$		$0.3 \cdot \text{VDD}$	V
Pull up resistor	diagnostic mode	25	50	100	k Ω
Output resistance Ron(OUT7-0)	active mode I _{out} =200mA, VCC=12V		2.5	4.0	Ω
Output current limitation I _{lim} (OUT7-0)	VCC=12V and V _{out} =0V	250		500	mA
Output short circuit threshold (OUT7-0)		$2/3 \text{VCC} - 0.5$	$2/3 \text{VCC}$	$2/3 \text{VCC} + 0.5$	V
Over voltage Shut-Off threshold	VCC	18.0	21.0	24	V
Over voltage Shut-Off Hysteresis	VCC		1.0		V
Over temperature Shut-Off	T _j	150	165	180	$^{\circ}\text{C}$

Name	Function
VCC1, VCC2	power inputs, both inputs need to be connected.
GND	circuit ground
VDD	5V logic supply
OUT7,	OUT0 power outputs
DATAI	data input
STROBE	data is latched on the high level of strobe
ADR2, ADR1, ADR0	address for output selection
DATAO	data output
OTB	open drain output that indicates that the IC is in over temperature protection
CEN	chip enable signal (in a system with only one IC, it is possible to connect this signal directly to VDD).
Pin Assignment	
Pin 1: VDD	Pin 20: CEN
Pin 2: OTB	Pin 19: DATAO
Pin 3: GND	Pin 18: OUT7
Pin 4: OUT0	Pin 17: OUT6
Pin 5: OUT1	Pin 16: VCC
Pin 6: VCC	Pin 15: OUT5
Pin 7: OUT2	Pin 14: OUT4
Pin 8: OUT3	Pin 13:STROBE
Pin 9:ADR2	Pin 12:DATAI
Pin 10:ADR1	Pin 11: ADR0

Reliability Information

Melexis devices are classified and qualified regarding suitability for infrared, vapor phase and wave soldering with usual (63/37 SnPb-) solder (melting point at 183degC).

The following test methods are applied:

- IPC/JEDEC J-STD-020A (issue April 1999)
Moisture/Reflow Sensitivity Classification For Nonhermetic Solid State Surface Mount Devices
- CECC00802 (issue 1994)
Standard Method For The Specification of Surface Mounting Components (SMDs) of Assessed Quality
- MIL 883 Method 2003 / JEDEC-STD-22 Test Method B102
Solderability

For all soldering technologies deviating from above mentioned standard conditions (regarding peak temperature, temperature gradient, temperature profile etc) additional classification and qualification tests have to be agreed upon with Melexis.

The application of Wave Soldering for SMD's is allowed only after consulting Melexis regarding assurance of adhesive strength between device and board.

For more information on manufacturability/solderability see quality page at our website:
<http://www.melexis.com/>

ESD Precautions

Electronic semiconductor products are sensitive to Electro Static Discharge (ESD).

Always observe Electro Static Discharge control procedures whenever handling semiconductor products

Disclaimer

Devices sold by Melexis are covered by the warranty and patent indemnification provisions appearing in its Term of Sale. Melexis makes no warranty, express, statutory, implied, or by description regarding the information set forth herein or regarding the freedom of the described devices from patent infringement. Melexis reserves the right to change specifications and prices at any time and without notice. Therefore, prior to designing this product into a system, it is necessary to check with Melexis for current information. This product is intended for use in normal commercial applications. Applications requiring extended temperature range, unusual environmental requirements, or high reliability applications, such as military, medical life-support or life-sustaining equipment are specifically not recommended without additional processing by Melexis for each application.

The information furnished by Melexis is believed to be correct and accurate. However, Melexis shall not be liable to recipient or any third party for any damages, including but not limited to personal injury, property damage, loss of profits, loss of use, interrupt of business or indirect, special incidental or consequential damages, of any kind, in connection with or arising out of the furnishing, performance or use of the technical data herein. No obligation or liability to recipient or any third party shall arise or flow out of Melexis' rendering of technical or other services.

© 2002 Melexis NV. All rights reserved.

For the latest version of this document, go to our website at:

www.melexis.com

Or for additional information contact Melexis Direct:

Europe and Japan:

Phone: +32 13 670495
E-mail: sales_europe@melexis.com

All other locations:

Phone: +1 603 223 2362
E-mail: sales_usa@melexis.com

QS9000, VDA6.1 and ISO14001 Certified