

Features and Benefits

- Programmable Linear Hall IC
- Quad Switched / Chopper Stabilized
- Ratiometric Output for A/D Interface
- Adjustable Quiescent Voltage (V_{OQ})
- Very Low Quiescent Voltage Temperature Drift
- Adjustable Sensitivity
- Adjustable Temperature Compensation of Sensitivity

Applications

- Linear Position Sensing
- Rotary Position Sensing
- Current Sensing

Ordering Information

Part No.	Temperature Suffix	Package	Temperature Range
MLX90215	L	VA(4 Lead SIP)	-40°C to 150°C
MLX90215	E	VA(4 Lead SIP)	-40°C to 85°C

Functional Diagram

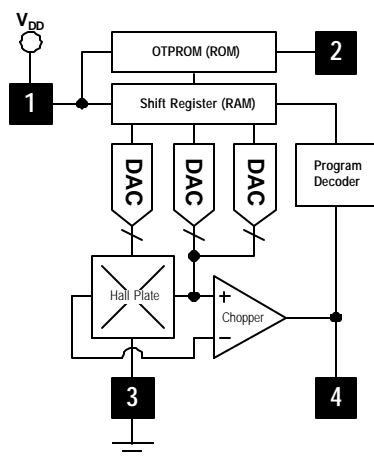

- Pin 1 - V_{DD} (Supply)
 Pin 2 - Test/Readback Enable
 Pin 3 - V_{SS} (Ground)
 Pin 4 - Output

Description

The MLX90215 is a Programmable Linear Hall Effect sensor IC fabricated utilizing silicon-CMOS technology. It possesses active error correction circuitry which virtually eliminates the offset errors normally associated with analog Hall Effect devices. All magnetic response functions of the MLX90215 are fully programmable for even greater versatility. The V_{OQ} ($V_{OUT@ B=0}$), sensitivity, direction of slope and the magnitude of sensitivity drift over temperature, are all programmable.

The ratiometric output voltage is proportional to the supply voltage. When using the supply voltage as a reference for an A/D converter, fluctuations of $\pm 10\%$ in supply voltage will not affect accuracy. When programmed for a conventional sensitivity (with a positive gain), the voltage at the output will increase as a South magnetic field is applied to the branded face of the MLX90215. Conversely, the voltage output will decrease in the presence of a North magnetic field. The MLX90215 has a sensitivity drift of less than $\pm 1\%$ error, and V_{OQ} stability drift of less than $\pm 0.4\%$ error, over a broad temperature range.

Note: Static sensitive device, please observe ESD precautions.

MLX90215 Electrical Specifications

Parameter	Symbol	Test Conditions	Min	Typ	Max	Units
Supply Voltage	V _{DD}	Operating	4.5	5.0	5.5	V
Supply Current	I _{DD}	B = 0, V _{DD} = 5V, I _{OUT} = 0	2.5	4.0	6.5	mA
Output Current (1)	I _{OUT}	V _{DD} = 5V ± 10%	-2	-	2	mA
Quiescent Output Voltage (2)	V _{OQ}	10-Bit Programmable, B = 0	0.5	-	4.5	V
Output Voltage (1)	V _{OH}	V _{DD} = 5V, I _{OUT} = -2mA	4.50	4.65		V
Output Voltage (1)	V _{OL}	V _{DD} = 5V, I _{OUT} = 2mA		0.35	0.50	V
Sampling Rate	f _{SAMP}	RoughGain @ Max and Min	4	-	40	kHz
Bandwidth (3)	BW	RoughGain @ Min		-	1.300	kHz
Bandwidth (3)	BW	RoughGain @ Max	0.130	-		kHz
Impulse Response Time (6)	T _{RMIN}	RoughGain @ Min	25	-		µs
Impulse Response Time (6)	T _{RMIN}	RoughGain @ Max	250			µs
Offset Voltage Adjustment Resolution	ΔV _{OQ}	B = 0, T _A = 25°C	-1.5	-	1.5	mV
Offset Voltage Drift over Temperature	ΔV _{OQ} /ΔT	B = 0, T _A = -40°C to 150°C S < 100mV/mT & V _{OQ} > 0.75V	-20	-	20	mV
Offset Voltage Drift (2) over Temperature	ΔV _{OQ} /ΔT	B = 0, T _A = -40°C to 150°C S > 100mV/mT & V _{OQ} < 0.75V	-40	-	40	mV
Range of Sensitivity (7)	s	13-Bit Programmable	5	-	140	mV/mT
Peak to Peak Noise (4)			8	25	60	mV
Output Resistance	R _{OUT}			6		Ω
Sensitivity Drift(5)		T _A = 25°C	-1	-	1	%

Notes:

- (1) If output current and voltage specifications are exceeded, linearity will be degraded.
- (2) If V_{OQ} is programmed beyond these limits, the temperature compensation may become a problem at high temperatures. It is not recommended to program values of V_{OQ} below 1V or above 4V when sensitivity exceeds 100 mV/mT. Temperature instability can occur on some devices under these conditions.
- (3) Bandwidth is inversely proportional to ROUGHGAIN.
- (4) Peak to Peak Noise is a function of ROUGHGAIN setting. See page 5, Peak to Peak Noise versus Sensitivity.
- (5) Sensitivity drift is independent of other parameters and does not include individual tolerances (ΔV_{OQ} or ΔV_{OQ}/ΔT). The tolerance for sensitivity is ± 1% of its initial value. This does not include tolerance stack-up.
- (6) If the impulse occurs in the middle of a sample interval, the small signal response delay will double. If a 50% to 100% impulse, slew rate may result in double or triple delay.
- (7) 1 mT = 10 Gauss

How does it Work?

The MLX90215 programming is done through the output pin, by changing supply voltage levels. Please note that the V_{DD} is raised to approximately 13V and 18V during programming. **Any connected components must also tolerate this voltage excursion.** When the supply voltage is at 4.5V to 5.5V, the output behaves normally. If the supply voltage is raised to 13V, the output then behaves as an input, or LOAD mode, allowing the 31-bit word to be clocked in. All data is loaded through a single line, with no dedicated clock signal. Clock and data are integrated into one signal which is initiated with the beginning of the LOAD sequence, then clocked with the positive edge of each bit. Variables are changed with the PC software and loaded into the temporary register of the device (RAM) via the timings of the programmer's microcontroller. Data can be loaded as many times as desired while in LOAD mode. Once a word is loaded, results are checked by observing the output voltage. This can be done with an external Voltmeter attached directly to pin 4 of the device, or with the internal ADC of the programmer. Once the desired program is loaded, the word can be "Zapped" permanently into ROM.

This is done when the supply voltage rises above 18V, or ZAP mode, creating enough current to "zap" 31 zener diodes which correspond to the temporary register. The ZAP function is a one-time function and cannot be erased.

The above description is only for reference. The voltage levels and data transfer rates are completely controlled by the ASIC programmer. For more information on the programmer hardware, contact Melexis and request a datasheet for the SDAP programmer.

Programming The Quiescent Offset Voltage (V_{OQ})
10 bits, 1024 steps of resolution, are allotted to adjust the Quiescent Offset Voltage (V_{OQ}). By utilizing the

Table 1 - Programming Offset Voltage (V_{OQ})

HalfVDD	OffsetDAC	Output	Units
0	0	4.97	V
0	512	2.47	V
0	1023	0.03	V
1	0	3.07	V
1	512	2.45	V
1	1023	1.83	V

HALFVDD function, the V_{OQ} can be set to one of two ranges. With the HALFVDD function disabled, the V_{OQ} can be programmed within a range of 10% to 90% V_{DD} with about 5mV per step resolution. With the HALFVDD function enabled, the device may be programmed within a 2V to 3V window with less than 1mV per step resolution

Programming the Sensitivity (Gain)

The sensitivity is programmed with a ROUGHGAIN and a FINEGAIN adjustment. The ROUGHGAIN is adjusted by utilizing three bits, or 8 increments. The FINEGAIN is programmed with 10 bits or 1024 increments. The sensitivity can be programmed within a range of 5mV/mT to 140mV/mT. Another 1-bit function allows the direction of the sensitivity to be reversed. The INVERTSLOPE function, when activated, will cause the Voltage output of the MLX90215 to decrease in the presence of a South magnetic field, and to increase in the presence of a North magnetic field. Table 2 expresses examples of sensitivity resulting from programming ROUGH GAIN and FINE GAIN codes, with the INVERT SLOPE function turned off.

Note: Tables 1 and 2 are examples how various codes affect the

Table 2 - Programming Sensitivity

RoughGain	FineGain	Output	Units
0	0	4.1	mV/mT
0	1023	9.4	mV/mT
1	0	6.2	mV/mT
1	1023	14.6	mV/mT
2	0	9.5	mV/mT
2	1023	22.4	mV/mT
3	0	14.2	mV/mT
3	1023	33.1	mV/mT
4	0	21.5	mV/mT
4	1023	50.4	mV/mT
5	0	31.3	mV/mT
5	1023	72.5	mV/mT
6	0	46.2	mV/mT
6	1023	107	mV/mT
7	0	68.9	mV/mT
7	1023	140	mV/mT

Temperature Compensation

Temperature compensation (TC) is defined as the change in sensitivity over temperature. Expressed in (Parts Per Million per Degree Celcius) ppm/°C.

$$TC = \frac{Sens_{T1} - Sens_{T2}}{Sens_{25}} * \frac{1}{T1 - T2} * 10^6 \frac{ppm}{^{\circ}C}$$

Sens_{T1} = Sensitivity measured at Temperature 1 (T1)

Sens_{T2} = Sensitivity measured at Temperature 2 (T2)

Sens₂₅ = Initial Sensitivity measured at 25°C

Table 3 - Temperature Compensation

TC Code	Min	Typical	Max	Units
0	-600	-450	-300	ppm/°C
1	-535	-385	-235	ppm/°C
2	-465	-315	-165	ppm/°C
3	-390	-240	-90	ppm/°C
4	-300	-150	0	ppm/°C
5	-235	-85	65	ppm/°C
6	-150	0	150	ppm/°C
7	-85	65	215	ppm/°C
8	125	275	425	ppm/°C
9	125	360	510	ppm/°C
10	210	435	585	ppm/°C
11	285	515	665	ppm/°C
12	450	600	750	ppm/°C
13	535	685	835	ppm/°C
14	600	750	900	ppm/°C
15	680	830	980	ppm/°C
16	1150	1300	1450	ppm/°C
17	1230	1380	1530	ppm/°C
18	1320	1470	1620	ppm/°C
19	1405	1555	1705	ppm/°C
20	1490	1640	1790	ppm/°C
21	1575	1725	1875	ppm/°C
22	1665	1815	1965	ppm/°C
23	1750	1900	2950	ppm/°C
24	2165	2365	2565	ppm/°C
25	2340	2490	2640	ppm/°C
26	2425	2575	2725	ppm/°C
27	2500	2650	2800	ppm/°C
28	2595	2745	2895	ppm/°C
29	2680	2830	2980	ppm/°C
30	2710	2910	3110	ppm/°C
31	2775	2975	3175	ppm/°C

Programming the Temperature Compensation

The MLX90215 has a 5-bit (32 step) programmable adjustment that changes its sensitivity drift over a given temperature range. By adjusting the TC code the sensitivity can be programmed to increase as temperature increases to counteract the decrease in magnetic flux most magnets display over temperature. For example a SmCo (Samarium Cobalt) magnet has a temperature coefficient of approximately -300 ppm/°C. The MLX90215 can be programmed with a TC of 300 ppm/°C to counteract the TC of the magnet and greatly improve linearity over temperature.

Table 3 (left) illustrates the way the TC code affects the sensitivity temperature drift. Also note in Table 3, the overlap in TC codes. The numbers in the table represent typical results and are for reference only. For accurate results the TC code must be determined experimentally. This Tc code map applies to MLX90215's with a second line brand showing "15DXX"

Special Note

The MLX90215 programmed with a zero TC code (default) has a typical TC value between the range of -300 to -600 ppm/°C. This means sensitivity will decrease slightly as temperature increases. The slightly negative initial TC value allows the MLX90215 to be accurately programmed up to 0 TC. Almost all magnets have a naturally negative TC code. The natural TC of a magnet added with the initial negative TC value of the MLX90215 could degrade linearity over a large temperature span. Using a TC code of 6, 7, or 8 will give the MLX90215 a slightly positive TC code.

Early revisions of the MLX90215 with second line brand of "15AXX" should refer to factory for Tc code

Condition	Output Level
V _{OUT} Shorted to V _{DD}	V _{OUT} = V _{DD}
V _{OUT} Shorted to V _{SS}	V _{OUT} = V _{SS}
V _{OUT} open with pull up load	V _{OUT} = V _{DD}
V _{OUT} open with pull down load	V _{OUT} = V _{SS}
V _{SS} open with pull up load	V _{OUT} = V _{DD}
V _{SS} open with pull down load > 10 K Ohms	V _{OUT} = V _{DD} or 94% V _{DD}
V _{DD} open with pull up load > 4.7 K Ohms	V _{OUT} = V _{SS} or 3% V _{DD}
V _{DD} open with pull down load	V _{OUT} = V _{SS}

MLX90215 Performance

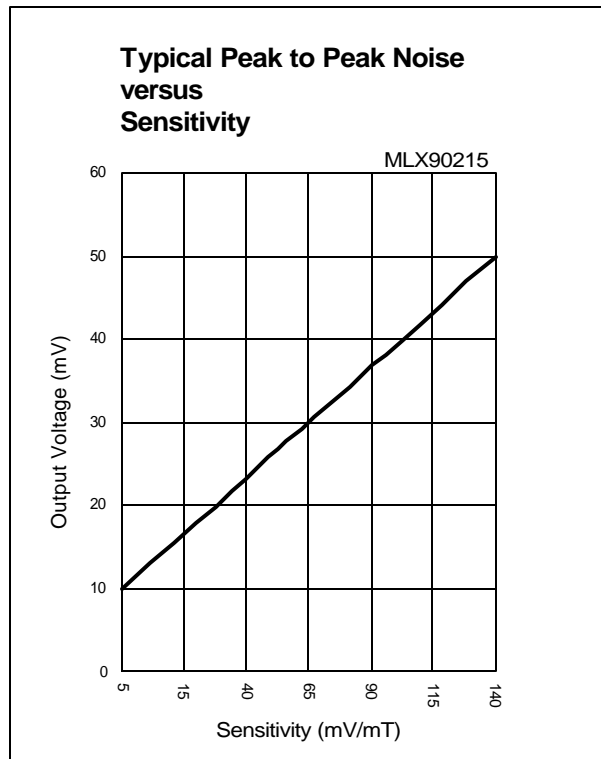
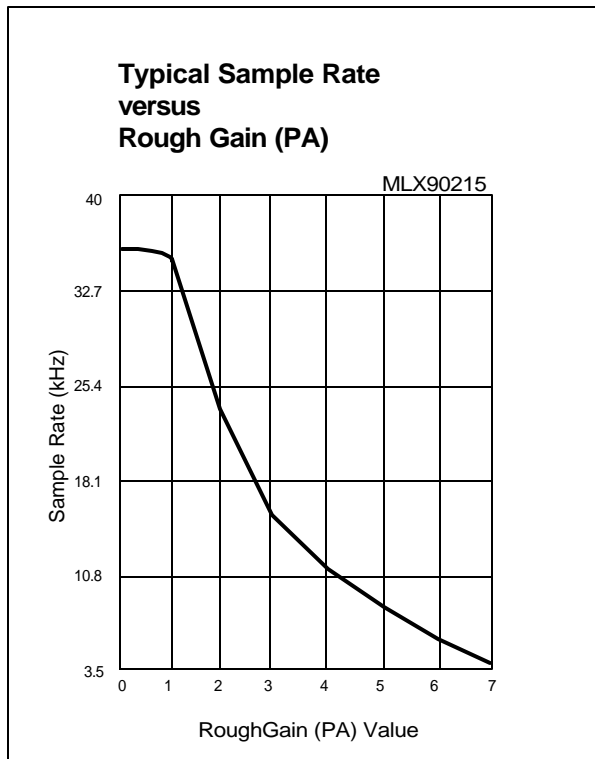
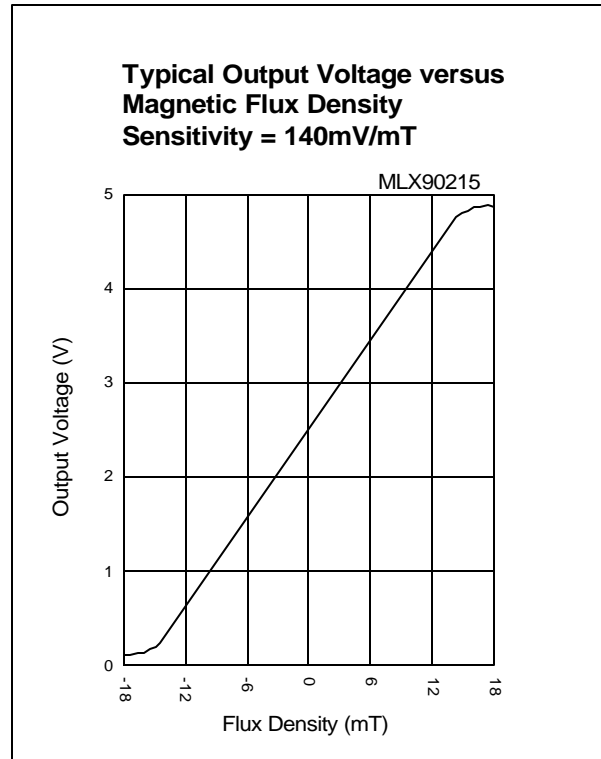
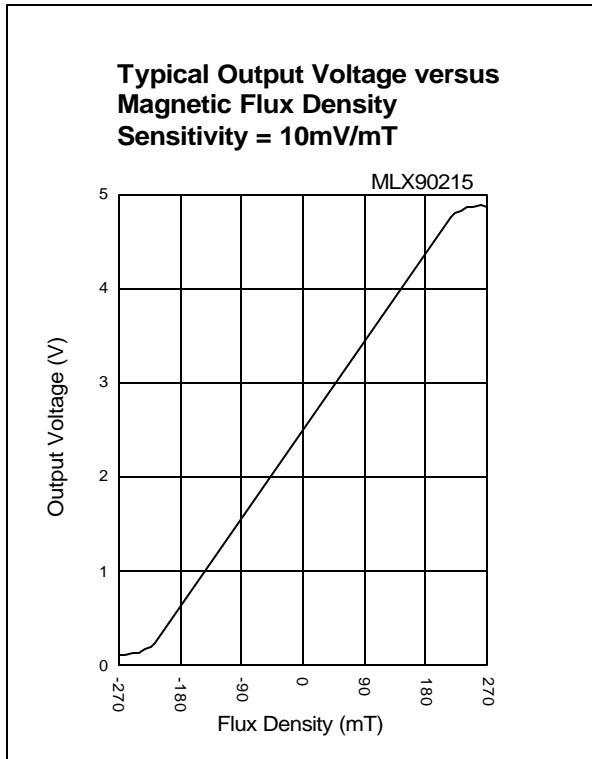

Melexis Programmer

Melexis offers a programmer (PTC-01) for programming the MLX90215. The PTC-01 comes complete with windows based software that makes programming the MLX90215 simple. The programmer communicates with a PC via a RS232 serial interface. The programmer and software allows users to load settings in the MLX90215, take measurements, calibrate sensors, and program the MLX90215. For more information the PTC-01 goto www.melexis.com, or contact Melexis.

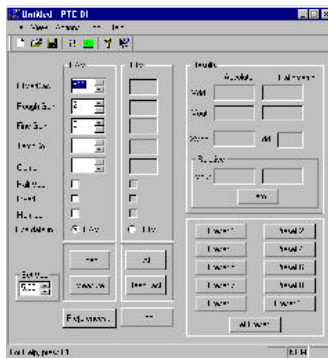

Left, PTC-01 windows based software. Works with any IBM compatible PC running windows 9x.

Absolute Maximum Ratings

Supply Voltage (Over Voltage)	18V
Supply Voltage (Operating)	5V ± 10%
Reverse Voltage Protection	-14.5V
Magnetic Flux Density	Unlimited
Supply Current, I _{DD}	6.5 mA
Output Current (Short to V _{DD})	+12 mA
Output Current (Short to V _{SS})	-12 mA
Operating Temperature Range, T _A	-40°C to 150°C
Storage Temperature Range, T _S	-55°C to 165°C
ESD Sensitivity	±7kV

Melexis PTC-01 Programmer

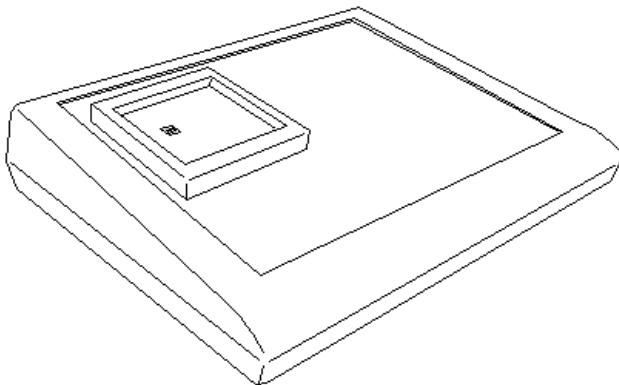

Pin Description Recommended Wiring

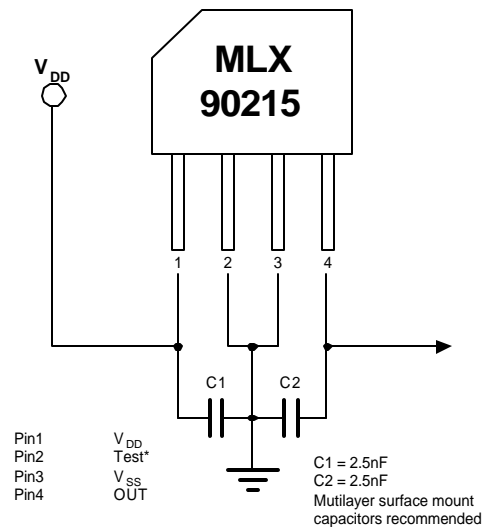

*Readback diagnostic use only. Pin 2 is NOT for programming device. For best results, tie to GND.

Clamping the Output Voltage

The MLX90215 has a 2bit CLAMP feature which allows Four output voltage options. The CLAMP feature is independent of the gain, and will not effect sensitivity of the device. The table below illustrates limits for each of the four options.

Bit Value	Limits (% V_{DD})
0 (default))	no clamp
1	5 to 45
2	10 to 90
3	5 to 95

Application Comments

The following is a list of recommended operating parameters that will help to ensure the accuracy and stability of the MLX90215. These are not the absolute programming limits of the device.

- 1.) V_{OQ} is best programmed in the absence of any magnetic influence and to voltages closest to $1/2 V_{DD}$, where temperature drift will be $\pm 0.4\%$ or less. It is not recommended to use V_{OQ} values close to 0 volts or V_{DD} when programming extremely high sensitivity (> 100 mV/mT) values. Temperature instability may be observed on some devices under these conditions.
- 2.) Best linearity of sensitivity is obtained when V_{OQ} is programmed at $1/2 V_{DD}$. This is with the $1/2 V_{DD}$ function enabled.
- 3.) Best linearity of sensitivity is obtained when the gain is programmed between 5mV/mT and 100mV/mT.
- 4.) Best temperature stability is realized when the temperature compensation function is programmed to zero ppm/ $^{\circ}C$.
- 5.) The Test/Readback pin is for diagnostic use only. This pin is normally tied to GND. Contact Melexis for more details on programming this device.

Installation Comments

- 1.) Avoid mechanical stress on leads or package. Stress may cause V_{OQ} shift.
 - A.) Avoid bending leads at the package interface.
 - B.) Support the leads by clamping, when bending.
 - C.) Avoid gluing device to another material. This may cause temperature-related stress.
- 2.) CMOS products are static sensitive devices, please observe ESD precautions.
- 3.) Observe temperature limits during soldering.

Bit Allocation Table

Bit	Function
1	INVERTSLOPE
2	OFFSETDAC 5
3	OFFSETDAC 6
4	OFFSETDAC 7
5	OFFSETDAC 8
6	OFFSETDAC 9
7	OFFSETDAC 4
8	OFFSETDAC 3
9	OFFSETDAC 2
10	OFFSETDAC 1
11	OFFSETDAC 0
12	FINEGAIN 0
13	FINEGAIN 1
14	FINEGAIN 2
15	HALFVDD
16	FINEGAIN 3
17	FINEGAIN 4
18	FINEGAIN 5
19	FINEGAIN 8
20	FINEGAIN 9
21	FINEGAIN 6
22	FINEGAIN 7
23	ROUGHGAIN 2
24	ROUGHGAIN 1
25	ROUGHGAIN 0
26	TEMP CO 0
27	TEMP CO 1
28	TEMP CO 2
29	TEMP CO 3
30	TEMP CO 4
31	CLAMP 1
32	CLAMP 0
33	MEMLOCK
34	TEST 0
35	TEST 1
36	TEST 2
37	TEST 3

Physical Characteristics

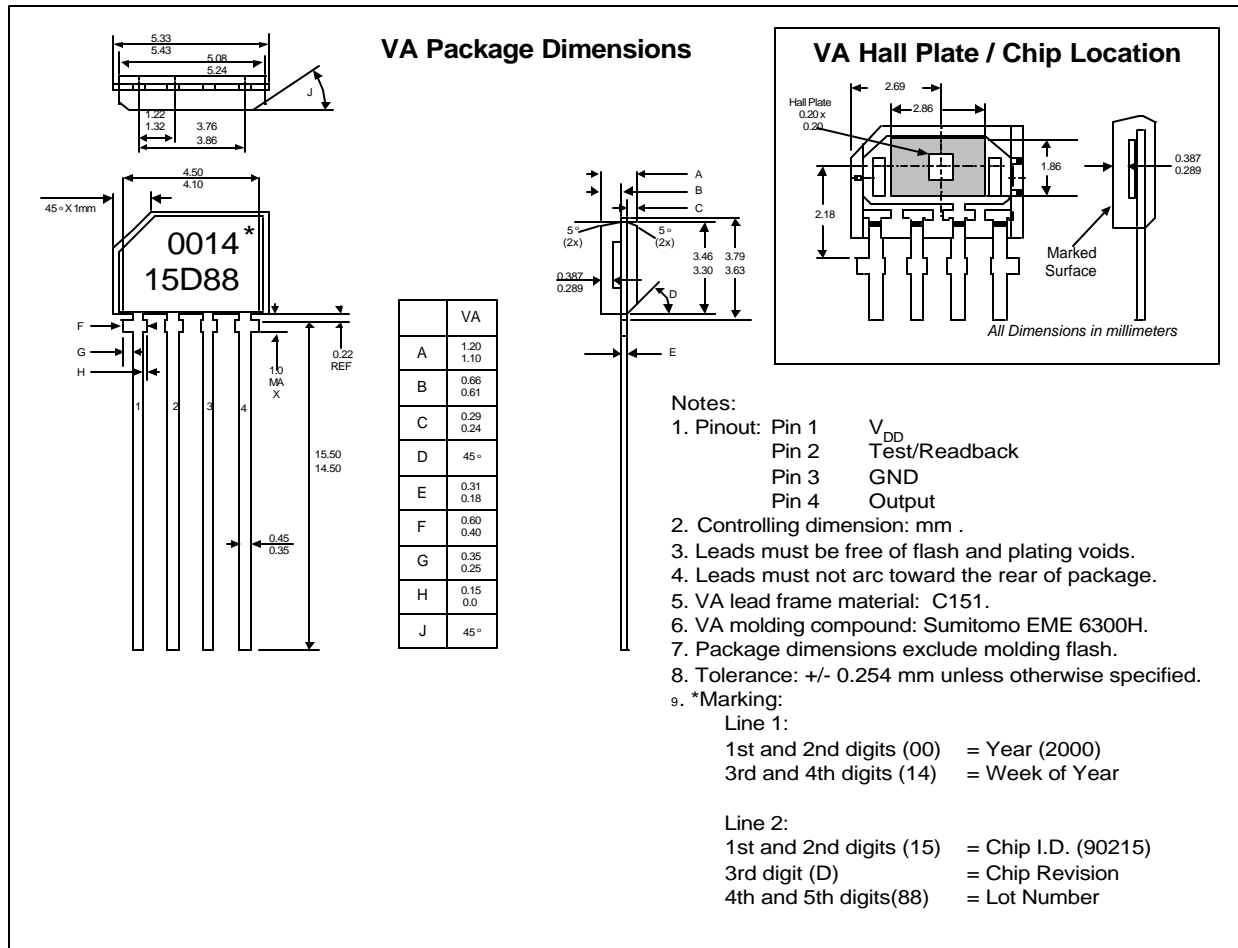

For the latest version of this document,
Go to our Website at:

WWW.Melexis.Com

For additional information
Contact Melexis direct at:

Europe and Japan
E-mail: sales_europe@melexis.com
Phone: 011-32-13-670-780

USA and Rest of World
Sales_usa@melexis.com
(603) 223-2362

Application Notes

Linear Precision Current Sensor

The Programmable gain, offset, and temperature compensation of MLX90215 allows great flexibility in the design of a current sensor.

Current flowing through a conductor can produce a proportional magnetic field. The MLX90215 can then produce an output voltage proportional to the current. Using the programmable gain and offset function the output of the MLX90215 can be adjusted to sense a wide range of current allowing for a flexible design.

Slotted Torroid Example Assuming infinite permeability of the core, the magnetic field through the air gap produced by a single wire turn is given by equation 2

Equation 2

$$B = \frac{I}{l_g} \mu_o$$

Where: I = current in Amperes
 B = magnetic field in Tesla
 l_g = length of air gap in Meters
 μ_o = Permeability of free space ($4\pi 10^{-7} \text{H/m}$)

This equation is a close estimate for the field in the air gap, but does not take into account magnetic losses in the core, fringing effects, and mechanical tolerances of the air gap. The programmable MLX90215 can be adjusted to compensate for these errors simplifying the design. The temperature compensation of MLX90215 can also be adjusted to counteract temperature losses of core.

For sensing a current $\pm 100\text{A}$, with an air gap of 2mm equation 2 yields a magnetic field range of $\pm 63\text{mT}$. The output range of the MLX90215 is 0.5V to 4.5V (4V full scale). Equations 3a and 3b yield a sensitivity of 32mV/mT and a V_{oq} of 2.5V.

Equation 3

- a) $S = 4000\text{mV} / 126\text{mT}$
- b) $V_{oq} = 4\text{V} / 2 + 0.5\text{V}$

The resulting gain of the current sensor is 20mV/A with an offset of 2.5V. For best results it is recommended that MLX90215 be programmed with a V_{oq} of 50% $V_{dd} / 2$ V_{dd} bit set.

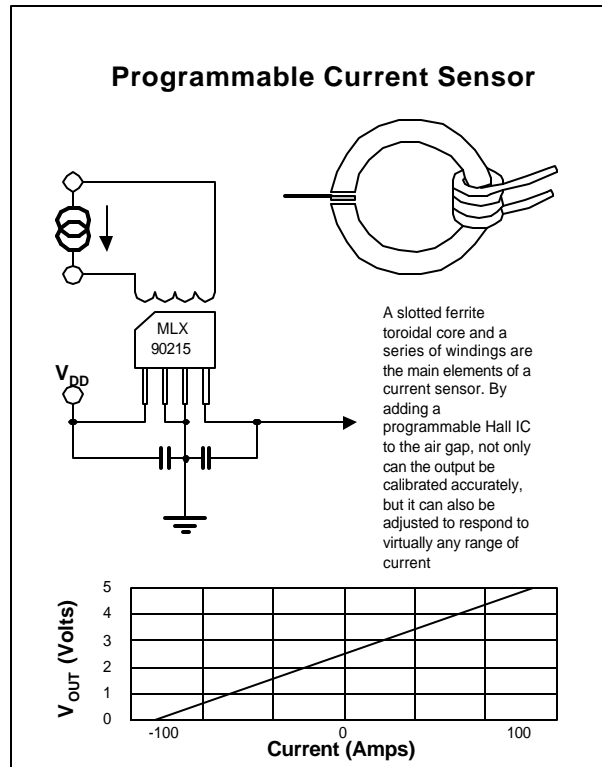

Magnetic Suppliers

Elna Ferrites Technologies Inc

Eastern Components

Fair Rite Products Corp