

Features

- Remote temperature measurement
- Fully linearised signals
- Analog voltage output
- Factory calibrated
- EEprom ECC
- Open drain relay driver output

Applications

- Automotive climate control
- Toasters, microwave ovens and other appliances that require temperature control
- Residential, commercial climate control and occupancy detection
- Industrial temperature transducer and monitoring applications

Ordering Information

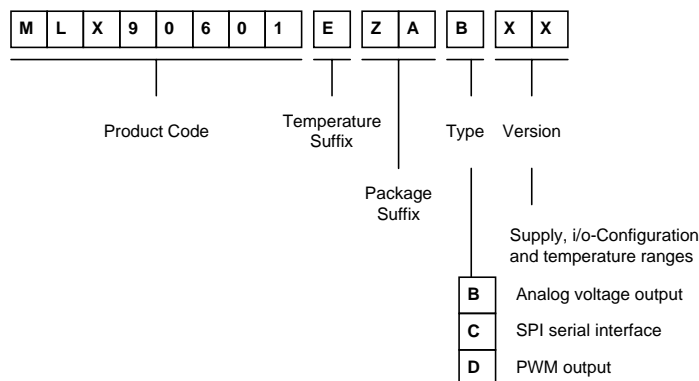

Part No	Temperature	Package	Type	Version	Description
MLX90601	E	ZA	B	AA	8 bit Analog -20/120°C 5V supply
MLX90601	E	ZA	B	BA	8 bit Analog 5/60°C 5V supply

Functional Diagram

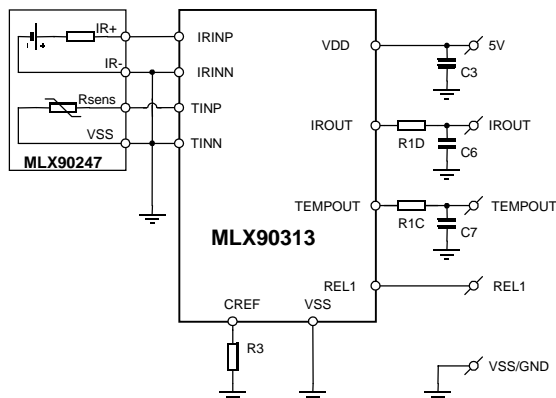

Description

The MLX90601B is a versatile IR thermometer module, which performs signal conditioning, linearisation and ambient temperature compensation. The module is built around the MLX90313 IR sensor interface, which uses high performance chopper stabilized amplifiers, providing excellent noise performance. The sensing element is the MLX90247 discrete IR thermopile.

The module is delivered factory calibrated. The output is an absolute analog voltage output for both sensor ambient temperature and the object temperature. The REL1 output is the open drain relay driver output available in MLX90313.

ELECTRICAL CHARACTERISTICS

Parameter	Symbol	Test Condition	Min	Typ	Max	Unit
Regulator and consumption						
Supply voltage range	Vin	VDD	4.5	5	6	V
Supply current	Idd	@ Ta=25°C		5	5.6	mA
POR threshold voltage	Vpor		1.1	1.3	1.5	V
IR-chain amplifier and output driver						
Power supply rejection ratio	PSSR	f ≤ 100kHz	75			dB
Input referred white noise	Vnir	rms-value			25	nV/√Hz
Chopper frequency	fc			8		kHz
Output voltage range		IROUT	0		Vdd-0.2	V
Output source current	Iod	IROUT	1			mA
Output sink current	Ios	IROUT	20			uA
DC Output impedance, drive	rod	IROUT			10	Ω
DC Output impedance, sink	ros	IROUT			100	Ω
Amplifier bandwidth	BW			500		Hz
Temp-chain amplifier and output driver						
Power supply rejection ratio	PSSR	f ≤ 100kHz	75			dB
Input referred white noise	Vntemp	rms-value			400	nV/√Hz
Chopper frequency	fc			15		kHz
Output voltage range	ORtemp	TEMPOUT	0		Vdd-0.2	V
Output source current	Iod	TEMPOUT	1			mA
Output sink current	Ios	TEMPOUT	20			uA
AC Output impedance	ro	TEMPOUT			100	Ω
Amplifier bandwidth	BW			500		Hz
Rel1 open drain relay driver						
High voltage protections			32			V
output impedance	Ro			10		Ω
ADC						
Resolution				12		bit
Monotonicity			guaranteed by design			
Differential non-linearity	DNL				0.4	LSB
Integral non-linearity	INL				½	LSB
Gain error		full scale			1	LSB
Total input-referred noise		Vref=3V			0.2	LSB
DAC						
Resolution				8		bit
Monotonicity			guaranteed by design			
Differential non-linearity	DNL				½	LSB
Integral non-linearity	INL				½	LSB

General Description

MLX90601 is a versatile IR thermometer built around the MLX90247 Discrete IR thermopile sensor with on-chip PTC and the MLX90313 Programmable IR sensor interface.

MLX90313 amplifies the signals coming from MLX90247 and converts them to digital by means of two high performance, low noise, chopper stabilized amplifiers and the 12-bit analog to digital converter. The digital unit on the interface then performs the ambient compensation of the IR signal. This results in two temperature signals, one representing the temperature of the object the IR sensor is pointed at (T_{object}) and one representing the temperature of the sensor (T_{ambient}). Both signals are then linearised and presented at the outputs (T_{object} is present at pin IROUT, T_{ambient} is present at pin TEMPOUT) by means of the 8 bit digital to analog converter.

The REL1 output is directly connected to the open drain relay driver output of MLX90313. This output is switched by means of a factory programmable comparator.

Unique Features

MLX90601 is an automotive grade IR thermometer that can be fitted to any contactless temperature measurement application by means of the programmable interface. The module is designed to cope with all standard qualification tests oriented towards the harsh automotive environment.

If so desired, all temperature ranges and comparator settings can be adapted to the application.

MLX90601 is delivered calibrated, relieving the customer of IR calibration.

Absolute Maximum Ratings

Supply Voltage, V_{DD} (overvoltage)	80V
Supply Voltage, V_{DD} (operating)	4.5V - 6V
Reverse Voltage Protection	-5V
Supply Current, I_{DD} @25°C	6 mA
Output Current, I_{OUT}	mA
Operating Temperature Range, T_{A}	-40°C - 125°C
Storage Temperature Range, T_{S}	-55°C - 150°C
ESD Sensitivity	4kV

Pinout

Pin	Symbol	Description
1	IROUT	Object temperature output
2	TEMPOUT	Ambient temperature output
3	VDD	Supply pin
4	REL1	Open drain, relay driver comparator output
5	VSS	Ground

Detailed Description

Analog Features

Supply

The module should be supplied directly with a nominal 5V regulated supply on pin VDD. (4.5V – 6V)

The power-on reset circuitry is internal to MLX90313. The module is fully operational 16 ms from the time the supply crosses 1.3V. The POR circuit will issue another reset if the supply voltage goes below 1.3V.

A/D

The MLX90313 on the module contains a 12-bit analog to digital converter. True 12-bit conversion is achieved by a fully differential analog part of the converter. Automatic calibration is implemented in the background, which allows precise conversion in a very wide temperature range.

D/A

An 8-bit digital to analog converter is used to output the data for the linearised T_{object}- and T_{ambient} signals.

Output drivers

The IROUT and TEMPOUT pin drivers can source 1mA and sink 20µA and are reverse voltage protected down to –5V relative to VSS. REL1 is an open drain relay driver output controlled by the comparator circuitry of MLX90313. The digital comparator's threshold (25°C) and hysteresis (2°C) are preset from factory. The comparator uses T_{object} as input signal.

Linearisation Unit

The linearisation unit of MLX90313 realizes 3 functions:

1. Offset measurement and calibration (offset drift compensation)
2. Measurement and offset cancellation
3. Linearisation.

Linearisation proceeds in two steps. In the first step the ambient temperature is calculated from the measured signal coming from the on-chip PTC temperature sensor of MLX90247. The value is stored in a dedicated register, controlling the output electronics.

In the second step the value of the ambient temperature is combined with the measured signal coming from the IR thermopile sensor inside MLX90247 to obtain a calculated value for the object temperature, based on the calibration data. The value is stored in a dedicated register and from there available for the output electronics.

Note that on request any arbitrary linearisation curve can be programmed. A very wide range of applications can be covered by MLX90601 family.

Sensor Characteristics

For detailed specification we refer to the datasheet on MLX90247, available from the Melexis website.

In a calibrated module the linearisation unit of MLX90313 takes all characteristics of the sensor into account, including all process variations they are subject to.

The TO-39 sensor housing of the thermopile has a 2.5mm diameter aperture, resulting in a 70° full angle field of view.

The silicon filter used as IR-window is treated with an antireflective coating that will pass minimum 75% of IR radiation in the wave length band from 7.5µm to 13.5µm. Below 5µm, 99.5% of incoming radiation is reflected by the filter.

Pin Descriptions

IROUT

IROUT analog voltage output pin. The voltage at this pin is a linear representation of T_{object}, the temperature of the object the IR sensor is pointed at. The driver can source at least 1mA and sink at least 20µA to/from an external load.

TEMPOUT

Tempout analog voltage output pin. The voltage

at this pin is a linear representation of $T_{ambient}$, the temperature of the IR sensor, as measured by the PTC inside MLX90247. The driver can source at least 1mA and sink at least 20 μ A to/from an external load.

VDD: Supply pin

REL1

Open drain relay driver output. The typical on-resistance of this driver is <math><10\Omega</math> with a supply voltage of $VDD=5V$.

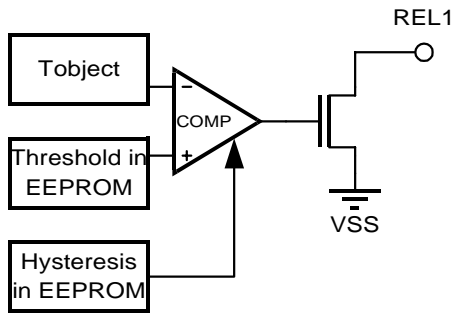

The comparator is a digital comparator, with a resolution of 12 bits. By default the input polarity is inverting. Threshold and hysteresis values are version dependent, as indicated below. These settings can be changed by factory programming on request.

Version	default REL1 settings	
	Threshold	Hysteresis
5/60°C version	25°C	$\pm 2^\circ\text{C}$
-20/120°C version	50°C	$\pm 5^\circ\text{C}$

VSS: Supply pin

Applications Information

Connection of the MLX90601 module into an application is straightforward. The 5V regulated supply should be connected between pin 3 (VDD) and pin 5 (VSS).

The outputs can be measured relative to VSS at pin 1 (IROUT) for T_{object} and pin 2 (TEMPOUT) for $T_{ambient}$, e.g. by means of a voltmeter. In an actual application the module outputs can be directly connected to the A/D inputs of a microcontroller, e.g. as a replacement for a conventional temperature sensor.

In many applications, the ambient temperature of the sensor is not needed. In this case, pin 2 can simply be left open.

The REL1 signal at pin 4 can be used as input for a digital I/O or to drive a relay (not shown).

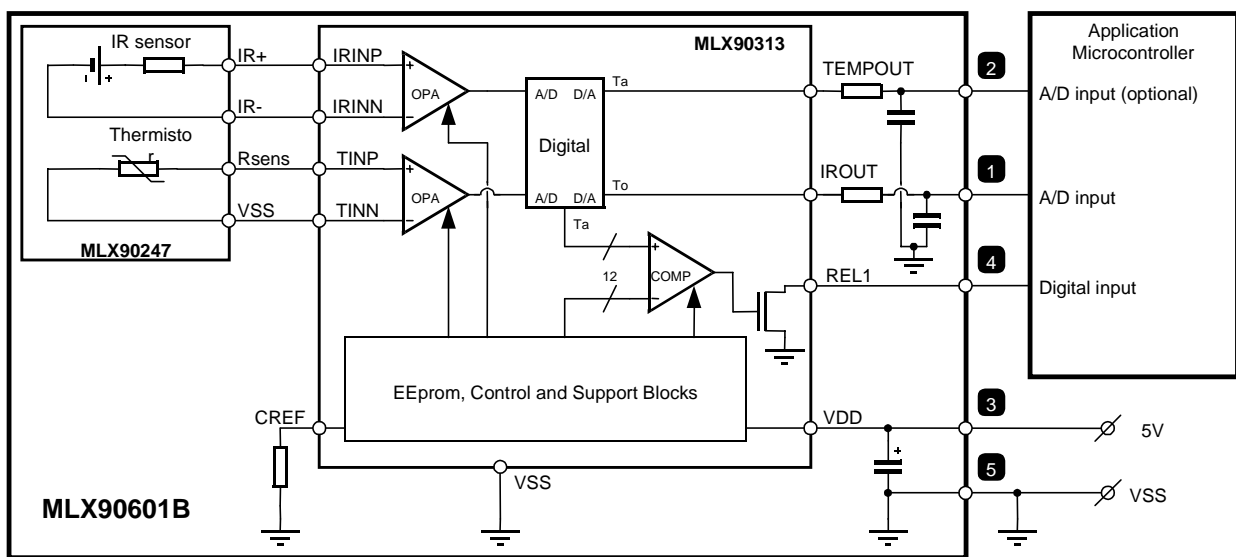

Output waveforms

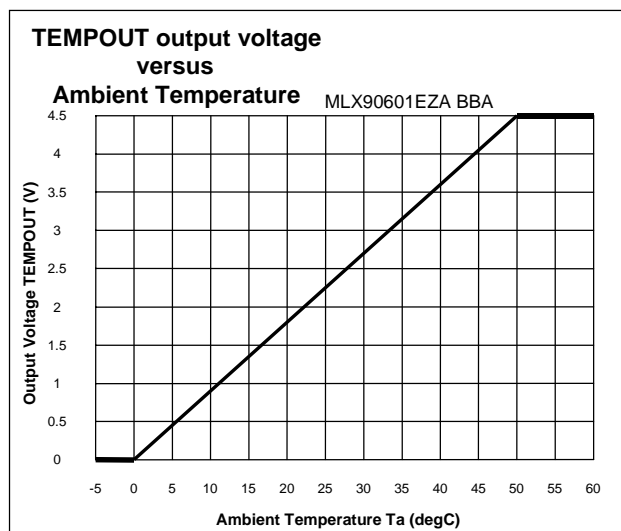
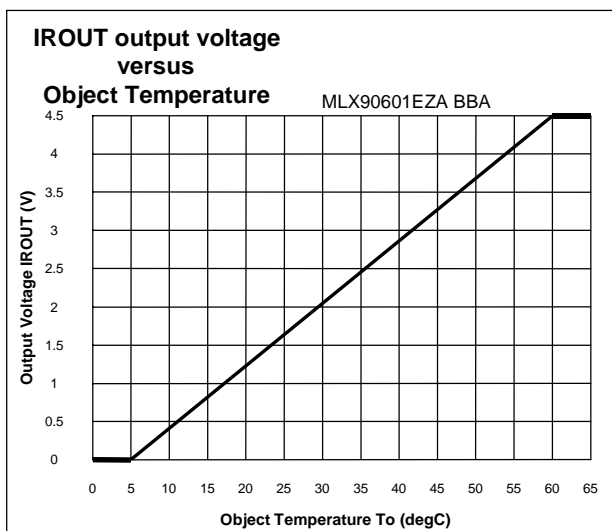

ESD Precautions

Electronic semiconductor products are sensitive to Electro Static Discharge (ESD). Always observe Electro Static Discharge control procedures whenever handling semiconductor products.

FAQ

Q: What is the accuracy?

A: For an object temperature range between 5°C and 60°C the accuracy of measurement is $\pm 1^\circ\text{C}$. For the wider object temperature range version (-20°C/120°C) the accuracy of measurement is $\pm 2^\circ\text{C}$.

Q: What is FOV?

A: The FOV or Field Of View is a definition of the area the sensor is 'seeing'. The sensor will detect radiation coming in at angles, relative to the sensor's central axis, from 0° to 35°. The full viewing angle is thus 70°.

Q: What is the useful temperature range?

A: There are two temperature ranges of interest; the temperature of the object (or target), which you are trying to measure and the temperature of the sensor. The sensor temperature, called T_{ambient} , should be between 0°C and 50°C. Outside this range the ambient temperature compensation will no longer work and calculation of the object's temperature will no longer be correct. The TEMPOUT output will saturate under this condition. The object temperature, called T_{object} , should be between 5°C and 60°C. (-20°C/120°C for wide range version) Outside this range the IROUT output will saturate.

Q: Can the temperature ranges be changed?

A: Yes, MLX90313 is a programmable device. Melexis selected a limited set of standard ranges that will fit the majority of applications in order to limit delivery times. However, if necessary, the ranges can be adapted for any particular application. Contact your sales representative for more information.

Glossary of Terms

ADC: Analog to Digital Converter

Ambient Compensation: The IR signal captured by a thermopile sensor is not only dependent on the temperature of the object (T_{object}) but also on the temperature of the sensor itself. Therefore the IR signal is compensated for this effect by means of the measured sensor temperature (T_{ambient}). This rather complex calculation is performed in the linearisation unit of MLX90313.

Chopper Amplifier: Special amplifier configuration aimed at ultra low offset.

DAC: Digital to Analog Converter.

EEProm: Non-volatile memory that can be electrically erased and rewritten. This type of memory is used to store configuration and calibration data for the module.

ECC: Error Checking and Correction. The EEPROM on board of MLX90313 is equipped with a checking and correction feature based on the Hamming Code method.

IR: Infrared. Every object emits infrared radiation in relation to its temperature. This effect can be used to measure this temperature without the need for physical contact.

Linearisation: The signal from a thermopile is not linear with the object temperature. MLX90313 is therefore equipped with a digital calculation unit that produces an output that is linear with the object temperature.

POR: Power-on reset: Reset circuit that starts the digital system in a known state whenever the supply voltage is cycled

PSSR: Power Supply Rejection Ratio: Measure for an amplifier's immunity to disturbances on the supply connections.

PTC: See Thermistor

T_a , T_{ambient} : The temperature of the IR sensor.

Target: or Object: The object the IR module is aimed at.

Thermistor: Temperature dependant resistor. Basically there are 2 types. The types that increase their resistance with rising temperature are PTC (positive thermal coefficient) type. The ones that decrease their resistance with rising temperature we call NTC (negative thermal coefficient) type. The MLX90313 can work with both types. The MLX90601 modules are equipped with sensors that use PTCs.

T_o , T_{object} : The temperature of the object one wishes to measure with the module

Disclaimer

Melexis reserves the right to periodically make modifications to product specifications. The information included herein is believed to be accurate and reliable. However, Melexis

assumes no responsibility for its use; nor for any infringements of patents or other rights of third parties, which may result from its use.

Physical Characteristics

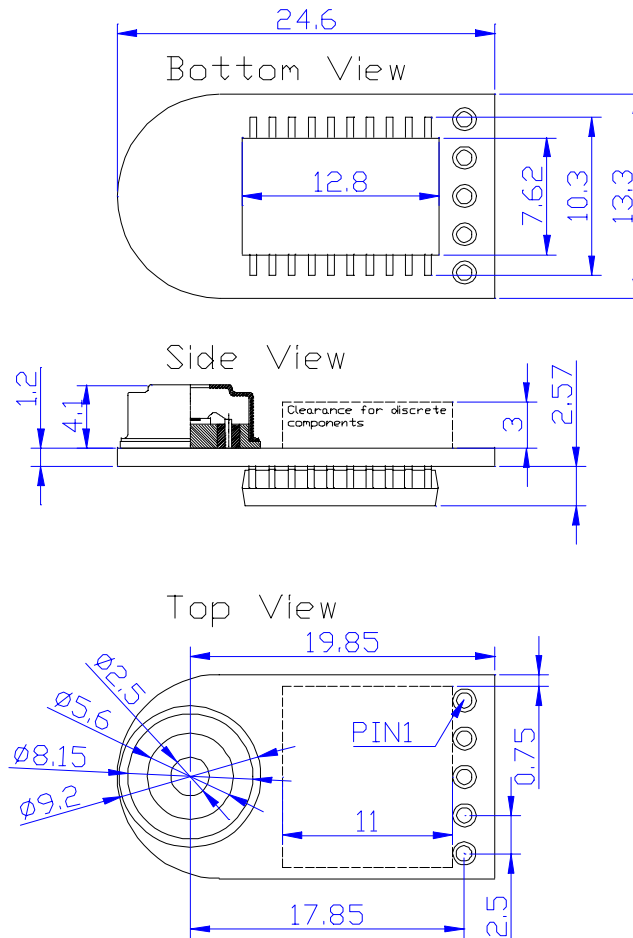

For the latest version of this document, go to our website at:
www.melexis.com

Or for additional information contact Melexis Direct:

Europe and Japan:	All other locations:
Phone: +32 13 61 16 31	Phone: +1 603 223 2362
E-mail: sales_europe@melexis.com	E-mail: sales_usa@melexis.com