

1. Features and Benefits

- High sensitivity
- Outstanding linearity
- High stability and reliability
- 0 – 30..50Bar Absolute pressure sensor
- Fully automotive qualified beyond AEC-Q100 requirements
- Compact design

2. Application Examples

- Automotive applications:
 - Engine/Transmission oil pressure
 - HVAC pressure
- Multi-Market:
 - HVAC/Refrigeration
 - Industrial process controls
 - Appliance
 - Consumer electronics
 - Ships and marine systems
 - Medical instruments

3. Ordering Information

Product Code	Temperature Code	Package Code	Option Code	Packing Form Code
MLX90816	L	UF	ABA-000	WB

Legend:

Temperature Code: L(-40°C to 150°C)
 Package Code: UF=Die on Foil
 Option Code: ABA-000
 Packing Form: WB = Wafer Box
 Ordering example: MLX90816LUF-ACA-000-WB

4. Functional Diagram

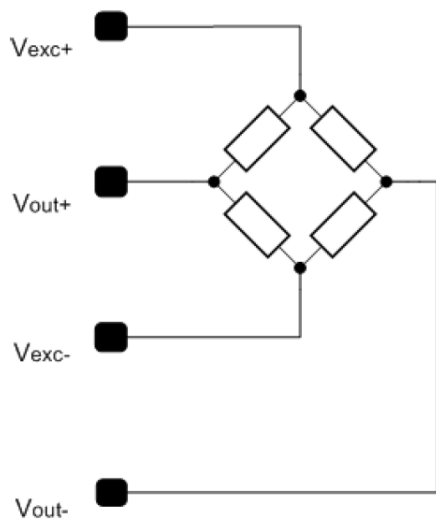

Figure 4-1 Functional block diagram MLX90816

5. General Description

The MLX90816 discrete micromachined absolute pressure sensors has been designed for an optimal performance when sensing pressures from 0 to 30..50 bar absolute. This device is fully automotive qualified. It can directly be used in non corrosive/non aggressive media applications. For harsh media, the MLX90816 can be used in a fluid filled module design. The sensor is a piezoresistive wheatstone bridge on a membrane made with a silicon micromachining process. As pressure is applied on the membrane a differential voltage change is seen across the Wheatstone bridge outputs while a bias voltage is applied to the bridge inputs.

The MLX90816 can be used in combination with the Melexis sensor interfaces ICs that can perform the conditioning of the bridge signal (MLX90328, MLX90329).

6. Table of Contents

1.	Features and Benefits.....	1
2.	Application Examples.....	1
3.	Ordering Information.....	1
4.	Functional Diagram.....	1
5.	General Description.....	1
6.	Table of Contents	2
7.	Absolute Maximum Ratings	3
8.	Die Information	3
9.	General Electrical Specifications.....	4
10.	Application Information	4
11.	Standard information regarding manufacturability of Melexis products with different soldering processes.....	5
12.	ESD Precautions	5
13.	Disclaimer	6
14.	Contact Information	6

7. Absolute Maximum Ratings

Parameter	Symbol	Min Value	Max Value	Units
Supply Voltage (overvoltage)	V		10	V
Operating Temperature Range	T	-40	150	°C
Storage Temperature Range	T	- 55	150	°C
Burst Pressure			200	Bar

Table 1: Absolute maximum ratings

Exceeding the absolute maximum ratings may cause permanent damage. Exposure to absolute maximum rated conditions for extended periods may affect device reliability.

8. Die Information

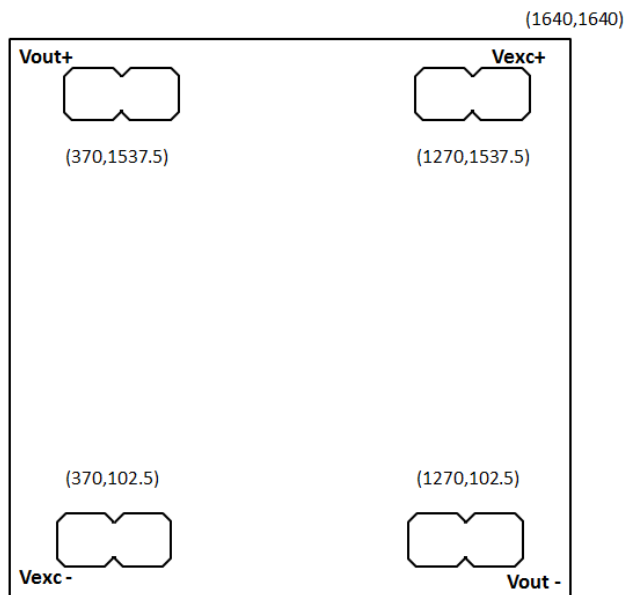

(0,0)

Figure 2 Chip Dimensions and bond pad positions (all dim. in μm)

Bond Pads opening size (x, y) in μm	Die thickness (μm)
(330,155)	700

Bond Pad	Function / Description
Vexc +	Supply voltage
Vout +	Positive output voltage
Vout -	Negative output voltage
Vexc -	Ground connection

Table 2: Bond pads description

9. General Electrical Specifications

DC Operating Parameters $T_A = 25\text{ }^\circ\text{C}$, $V_{DD} = 5\text{V}$, Pressure = 50 bar Full Scale unless otherwise specified.

Parameter	Symbol	Min	Max	Units
Sensitivity	S	0.42	.58	mV/V/bar
Bridge Resistance	Rb	3	5.5	k Ω
Offset	O	-30	30	mV
Non linearity (best fit)	NL	-0.2	0.2	%FS
Thermal Hysteresis	Hyst	-0.2	0.2	%FS
Thermal coefficient of Span	TCS	-0.23	-0.15	%FS/ $^\circ\text{C}$
Thermal coefficient of Offset	TCO	-0.06	0.06	%FS/ $^\circ\text{C}$
Thermal coefficient of bridge resistance	TCR	0.30	0.40	%FS/ $^\circ\text{C}$

Table 3: Electrical specifications

The MLX90816 can also be used with full scale pressures other than 50bar (30 to 50bar). Contact Melexis for detailed information on the IC performance at different full scale pressures.

10. Application Information

The MLX90816 is a very reliable discrete absolute pressure sensor fully automotive qualified. Like all Melexis pressure sensors it has been qualified beyond typical semiconductors qualification standards. For harsh media applications the MLX90816 can be used in a fluid filled housing.

If the application requires an amplified conditioned output the MLX90816 can be used in combination with Melexis sensor interfaces IC like the MLX90328 and the MLX90329. By programming some calibration settings in the sensor interface IC the sensitivity and offset variations from part to part as well as their variations over temperature can be compensated for.

11. Standard information regarding manufacturability of Melexis products with different soldering processes

Our products are classified and qualified regarding soldering technology, solderability and moisture sensitivity level according to following test methods:

Reflow Soldering SMD's (Surface Mount Devices)

- IPC/JEDEC J-STD-020
Moisture/Reflow Sensitivity Classification for Nonhermetic Solid State Surface Mount Devices (classification reflow profiles according to table 5-2)
- EIA/JEDEC JESD22-A113
Preconditioning of Nonhermetic Surface Mount Devices Prior to Reliability Testing (reflow profiles according to table 2)

Wave Soldering SMD's (Surface Mount Devices) and THD's (Through Hole Devices)

- EN60749-20
Resistance of plastic- encapsulated SMD's to combined effect of moisture and soldering heat
- EIA/JEDEC JESD22-B106 and EN60749-15
Resistance to soldering temperature for through-hole mounted devices

Iron Soldering THD's (Through Hole Devices)

- EN60749-15
Resistance to soldering temperature for through-hole mounted devices

Solderability SMD's (Surface Mount Devices) and THD's (Through Hole Devices)

- EIA/JEDEC JESD22-B102 and EN60749-21
Solderability

For all soldering technologies deviating from above mentioned standard conditions (regarding peak temperature, temperature gradient, temperature profile etc) additional classification and qualification tests have to be agreed upon with Melexis.

The application of Wave Soldering for SMD's is allowed only after consulting Melexis regarding assurance of adhesive strength between device and board.

Melexis recommends reviewing on our web site the General Guidelines [soldering recommendation](http://www.melexis.com/Quality_soldering.aspx) (http://www.melexis.com/Quality_soldering.aspx) as well as [trim&form recommendations](http://www.melexis.com/Assets/Trim-and-form-recommendations-5565.aspx) (<http://www.melexis.com/Assets/Trim-and-form-recommendations-5565.aspx>).

Melexis is contributing to global environmental conservation by promoting **lead free** solutions. For more information on qualifications of **RoHS** compliant products (RoHS = European directive on the Restriction Of the use of certain Hazardous Substances) please visit the quality page on our website: <http://www.melexis.com/quality.aspx>

12. ESD Precautions

Electronic semiconductor products are sensitive to Electro Static Discharge (ESD).

Always observe Electro Static Discharge control procedures whenever handling semiconductor products.

13. Disclaimer

Devices sold by Melexis are covered by the warranty and patent indemnification provisions appearing in its Term of Sale. Melexis makes no warranty, express, statutory, implied, or by description regarding the information set forth herein or regarding the freedom of the described devices from patent infringement. Melexis reserves the right to change specifications and prices at any time and without notice. Therefore, prior to designing this product into a system, it is necessary to check with Melexis for current information. This product is intended for use in normal commercial applications. Applications requiring extended temperature range, unusual environmental requirements, or high reliability applications, such as military, medical life-support or life-sustaining equipment are specifically not recommended without additional processing by Melexis for each application.

The information furnished by Melexis is believed to be correct and accurate. However, Melexis shall not be liable to recipient or any third party for any damages, including but not limited to personal injury, property damage, loss of profits, loss of use, interrupt of business or indirect, special incidental or consequential damages, of any kind, in connection with or arising out of the furnishing, performance or use of the technical data herein. No obligation or liability to recipient or any third party shall arise or flow out of Melexis' rendering of technical or other services.

© 2014 Melexis NV. All rights reserved.

14. Contact Information

For the latest version of this document, go to our website at
www.melexis.com

Or for additional information contact Melexis Direct:

Europe, Africa, Asia:

Phone: +32 1367 0495

E-mail:

sales_europe@melexis.com

America:

Phone: +1 248 306 5400

E-mail:

sales_usa@melexis.com

ISO/TS 16949 and ISO14001 Certified