

Features and Benefits

- Programmable high speed current sensor
- Programmable linear transfer characteristic
- Selectable analog ratiometric output
- Measurement range from 15 to 450mT
- Single die VA package RoHS compliant
- Wideband: DC to 200kHz
- Lead free component, suitable for lead free soldering profile 260°C (target), MSL1
- Short response time

Application Examples

- Inverter applications in HEV and EV
- BLDC motor current monitoring
- AC/DC converters
- Over current detection circuit

Ordering Information

Product Code	Temperature Code	Package Code	Option Code	Packing Form Code
MLX91209	L	VA	CAA-000	BU
MLX91209	L	VA	CAA-000	CR

Caption

Temperature Code: L = (-40°C to 150°C)
 Package Code: VA = SIP 4L (single in-line package)
 Option Code: CAA = Sensitivity Range 5-150mV/mT (typical: 50mV/mT)
 Packing Form: BU = Bulk / CR = Radial Tape
 Ordering Example: "MLX91209LVA-CAA-000-CR"

Functional Diagram

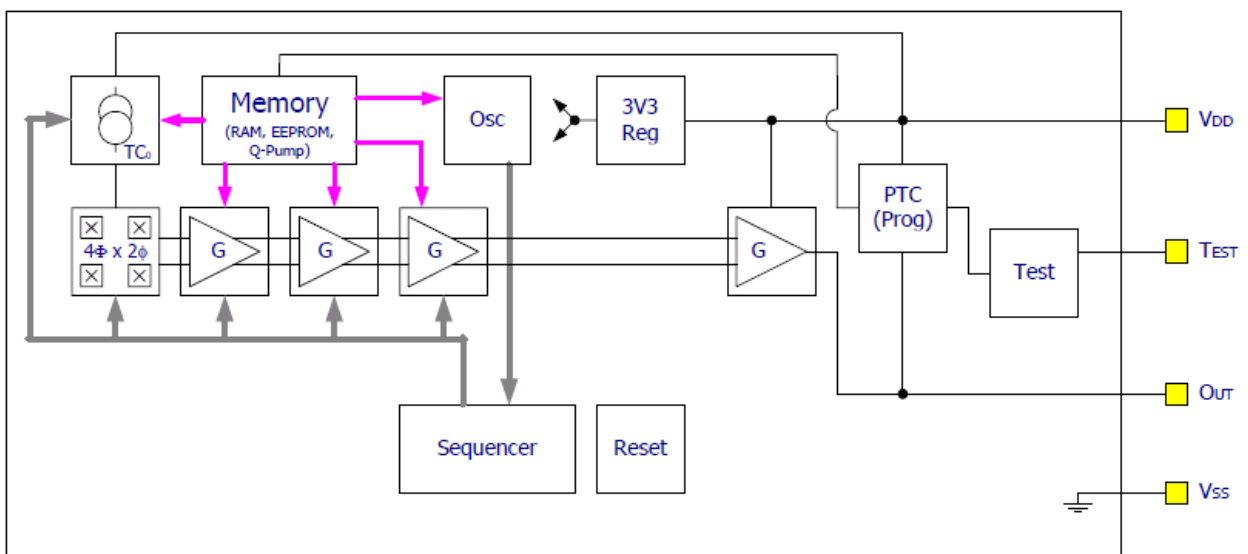

Figure 1: Block Diagram

General Description

The MLX91209 is a monolithic programmable Hall sensor IC featuring the planar Hall technology, which is sensitive to the flux density applied orthogonally to the IC surface. The sensor provides an output signal proportional to the applied magnetic flux density and is preferably suited for current measurement.

The transfer characteristic of the MLX91209 is programmable (offset, gain). The linear analog output is designed for applications where a very fast response is required, such as inverter applications.

In a typical application, the sensor is used in combination with a ring shaped soft ferromagnetic core. The Hall IC is placed in a small air gap and the current conductor is passed through the inner part of the ferromagnetic ring. The ring concentrates and amplifies the magnetic flux on the Hall sensor IC, which generates an output voltage proportional to the current flowing in the conductor.

Glossary of Terms

ADC	Analog to Digital Converter
DAC	Digital to Analog Converter
DNL	Differential Non Linearity
INL	Integral Non Linearity
LSB	Least Significant Bit
MSB	Most Significant Bit
NC	Not Connected
PTC	Programming Through Connector
TC	Temperature Coefficient in ppm/°C
Tesla	Units for the magnetic flux density, 1 mT = 10 Gauss

Absolute Maximum Ratings

Parameter	Symbol	Value	Units
Positive Supply Voltage	Vdd	+10	V
Reverse Supply Voltage		-0.3	V
Positive Output Voltage ⁽¹⁾		+10	V
Output Current	Iout	±70	mA
Reverse Output Voltage		-0.3	V
Reverse Output Current		-50	mA
Package Thermal Resistance	Rth	105	°C/W
Operating Ambient Temperature	T _A	-40 to +150	°C
Storage Temperature Range	T _S	-55 to +165	°C
Magnetic Flux Density		infinite	T

Table 1: Absolute maximum ratings

Exceeding the absolute maximum ratings may cause permanent damage. Exposure to absolute maximum rated conditions for extended periods may affect device reliability.

(1) Valid for supply=10V or supply-pin floating.

Table of Contents

Features and Benefits	1
Application Examples	1
Ordering Information	1
Functional Diagram	1
General Description	2
Glossary of Terms	2
Absolute Maximum Ratings	2
Table of Contents	3
Pin Definitions and Descriptions	4
General Electrical Specifications	4
Magnetic specification	5
Analog output specification	6
Programmable items	8
Self diagnostic	9
Recommended Application Diagrams	10
Standard information regarding manufacturability of Melexis products with different soldering processes	11
ESD Precautions	13
FAQ	13
Package Information	14
Disclaimer	15
Contact Information	15

Pin Definitions and Descriptions

Pin #	Name	Type	Function
1	VDD	Supply	Supply Voltage
2	OUT	Analog	Current Sensor Output
3	TEST/MUST	Digital	Test and Factory Calibration
4	VSS	Ground	Supply Voltage

Table 2: Pin definitions and descriptions

Unused pins should be connected to Ground for optimal EMC results.

General Electrical Specifications

Operating Parameters: $T_A = -40^\circ\text{C}$ to 125°C , $V_{dd} = 4.5\text{V}$ to 5.5V , $I_{out} = -2\text{mA}$ to 2mA , recommended application diagram, unless otherwise specified. Mentioned component values can have a $\pm 20\%$ tolerance.

Parameter	Symbol	Test Conditions	Min	Typ	Max	Units
Nominal Supply Voltage	V_{dd}		4.5	5	5.5	V
Supply Current	I_{dd}	No output load, application mode, $T_A = -40^\circ\text{C}$ to 150°C	7	12	14	mA
DC Load Current	I_{out}	R_{load} in range [6k Ω , 100k Ω]	-2		2	mA
Maximum Output Current (driving capability)	I_{max}	Inside this range, output voltage reaches 3 and 97% V_{dd}	-2		2	mA
Output Resistance		$V_{out} = 50\% V_{dd}$, $R_L = 10\text{k}\Omega$		1	5	Ω
Output Capacitive Load	C_{load}	Capacitive load for the stability of the output amplifier			10	nF
Output Resistive Load (pull-up and pull-down resistor)	R_{load}	Output resistive load for high linearity	6			k Ω
Output Short Circuit Current (Permanent)	I_{short}	Output shorted to V_{dd}	35		180	mA
		Output shorted to V_{ss}	35		180	mA
Output Leakage current	I_{leak}	High impedance mode ⁽¹⁾ $T_A = 150^\circ\text{C}$	0.5	1.5	20	μA
Output Voltage Swing (Linear Range)	V_{out_pu}	pull up $\geq 10\text{k}\Omega$	10		90	% V_{dd}
	V_{out_pd}	pull down $\geq 10\text{k}\Omega$	10		90	% V_{dd}
High-impedance mode levels ⁽¹⁾	$V_{out_HiZ_pu}$	pull-up $R_L \leq 25\text{k}\Omega$, $T \leq 125^\circ\text{C}$	95			% V_{dd}
	$V_{out_HiZ_pd}$	pull-down $R_L \leq 25\text{k}\Omega$, $T \leq 125^\circ\text{C}$			5	% V_{dd}
Under-voltage detection ⁽²⁾	V_{dd_uvd}	Low to High Voltage	3.15	3.3	3.45	V
	V_{dd_uvh}	Hysteresis	0.25	0.3	0.4	V
Ratiometry fault detection	V_{ratio_d}	Low to High Voltage	4		4.4	V
	V_{ratio_h}	Hysteresis	0.05		0.5	V
Over-voltage detection ⁽²⁾	V_{dd_ovd2}	Low to High Voltage	6.7		7.6	V
	V_{dd_ovh2}	Hysteresis	0.05		0.7	V

Table 3: General electrical parameters

(1) Refer to section *Self diagnostic*, Table 8.

(2) According to the following diagram:

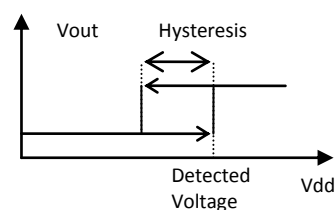

Magnetic specification

Operating Parameters $T_A = -40^{\circ}\text{C}$ to 125°C , $V_{dd} = 4.5\text{V}$ to 5.5V , unless otherwise specified.

Parameter	Symbol	Test Conditions / Comments	Min	Typ	Max	Units
Magnetic field range	B		± 15	± 45	± 450	mT
Linearity Error	NL	V_{dd} in range [4.5V, 5.5V] V_{out} in [10% V_{dd} , 90% V_{dd}]	-0.4		+0.4	%FS
Programmable Sensitivity	S		5	50	150	mV/mT
Sensitivity programming Resolution	Sres			0.1		%

Table 4: Magnetic specification

Sensor active measurement direction

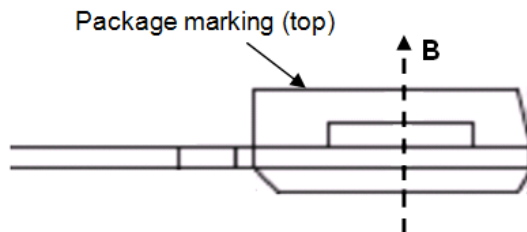

Figure 1: Magnetic Field Direction

Analog output specification

Timing specification

Operating Parameters $T_A = -40^{\circ}\text{C}$ to 125°C , $V_{dd} = 4.5\text{V}$ to 5.5V (unless otherwise specified).

Parameter	Symbol	Test Conditions / Comments	Min	Typ	Max	Units
Refresh rate	Trr		0.8	1	2	μs
Step Response Time	Tresp	Delay between the input signal reaching 90% and the output signal reaching 90%, (2V step at the output, input rise time = $1\mu\text{s}$) -Noise filter OFF -Noise filter ON		2	3	μs
				5	6	μs
Bandwidth	BW	-Noise filter OFF -Noise filter ON	200	250	300	kHz
			120	150	180	kHz
Power on Delay	T_{POD}	$V_{\text{out}} = 100\%$ of FS Pull-down resistor $\leq 100\text{k}\Omega$ During the Power-on delay, output will remain within the 10% fault band at all time.			5	ms
Ratiometry Cut-off Frequency	Fratio			250		Hz

Table 5: Timing specification for high speed analog output

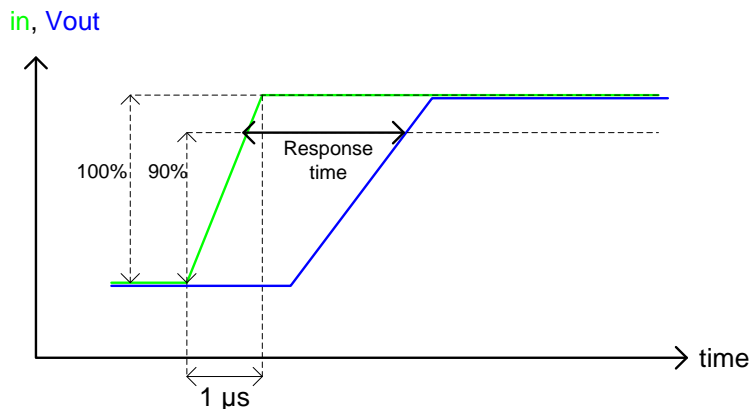

Figure 2: Response time definition

Accuracy specification

Operating Parameters $T_A = -40^{\circ}\text{C}$ to 125°C , $V_{dd} = 4.5\text{V}$ to 5.5V (unless otherwise specified).

Parameter	Symbol	Test Conditions	Min	Typ	Max	Units
Thermal Offset Drift ⁽¹⁾	$\Delta^T \text{Voq}$	Thermal offset drift referred to 25°C $S=50 \text{ mV/mT}$ (@ $V_{dd}=5\text{V}$) $\text{TC} = 0 \pm 150 \text{ ppm}/^{\circ}\text{C}$ $\text{Voq} = 50 \pm 0.2 \%V_{dd}$	-0.002		+0.002	$\%V_{dd}/^{\circ}\text{C}$
Thermal Offset Drift Resolution	$\Delta^T \text{VoqRes}$			0.00075		$\%V_{dd}/^{\circ}\text{C}$
Thermal Sensitivity Drift	TC		-1.5	0	+1.5	% of S
Thermal Sensitivity Drift resolution	TCres			40		ppm/ $^{\circ}\text{C}$
RMS Output noise	N_{rms}	$S=50\text{mV/mT}$, $Bw= 0\text{-}250\text{kHz}$, $\text{Trr}= 1\text{usec}$ -Noise filter OFF -Noise filter ON			0.2 0.12	$\%V_{dd}$ $\%V_{dd}$
Ratiometry Error Offset	ΔVoq	$\text{Voq} = 50\%V_{dd}$ $\Delta V_{dd} = 10\%V_{dd}$	-0.4		+0.4	% of Voq
Ratiometry Error Sensitivity	ΔS	$\Delta V_{dd} = 10\%V_{dd}$	-0.4		+0.4	% of S

Table 6: Accuracy specification for high speed analog output

(1) Thermal offset drift specification is only valid when RATIOMETRY is enabled.

Remarks to the achievable accuracy

The achievable target accuracy depends on end-of-line calibration in the application. Resolution for offset calibration is better than $0.1\%V_{dd}$. Trimming capability is higher than measurement accuracy. End-of-line calibration can increase overall system accuracy.

Programmable items

Parameter table

Parameter	Bits	Comment
VOQ[11:0]	12	Quiescent output level (0 gauss) adjustment
RG[2:0]	3	Rough gain adjustment
FG[9:0]	10	Fine gain adjustment
ENRATIO	1	Ratiometry enablement
TC1[7:0]	8	First order temperature compensation of the magnetic sensitivity
TC2HOT[4:0]	5	Extra temperature compensation of the magnetic sensitivity at high temperature
TC2COLD[4:0]	5	Extra temperature compensation of the magnetic sensitivity at low temperature
OFFDR2C[5:0]	6	Adjustment of the offset drift at low temperature after the VGA
OFFDR2H[5:0]	6	Adjustment of the offset drift at high temperature after the VGA
NOISEFILT	1	Noise filter enablement
CRC[15:0]	16	16-bit CRC for the checksum calculation of the configuration register.
ID[47:0]	48	Customer identification code

Table 7: Customer programmable items

Sensitivity programming (RG, FG)

The sensitivity can be programmed from 5 to 150 mV/mT, with the ROUGHGAIN (3 bits) and FINEGAIN (10 bits) parameters.

Offset / output quiescent voltage programming (VOQ)

The offset is programmable with 12 bits in 1.5 mV steps over the full output range. This corresponds to a calibration resolution of 0.03 %VDD. (The typical step would be $5V/4096 = 1.22$ mV, the actual step size can differ from the nominal value because of internal gain tolerance. The maximum step size of 1.5 mV is guaranteed).

Note: for optimal performance over temperature, VOQ should be programmed in the range 2 to 3V.

Output ratiometry (ENRATIO)

The ratiometry of the output versus the supply can be disabled by setting this bit to 0.

Note: for optimal performance over temperature, ratiometry should always be enabled (ENRATIO=1).

Sensitivity temperature drift programming (TC1, TC2COLD, TC2HOT)

First order sensitivity temperature drift can be trimmed from -2000 to 2000ppm/K with TC1. The programming resolution is 40ppm/K.

Second order sensitivity temperature drift can be trimmed from TC2COLD and TC2HOT. The programming resolution is 2ppm/K² for TC2COLD and 0.6ppm/K² for TC2HOT. The second order can also be seen as third order correction since cold and hot sides are independently adjusted.

Note: for optimal performance over temperature, the first order sensitivity drift compensation (TC1ST) should not exceed ± 500 ppm/K.

Offset temperature drift programming (OFFDR2C, OFFDR2H)

Offset temperature drift caused by the output amplifier can be compensated with these two parameters. This first order correction is done independently for temperatures over and below 25°C.

Note: two additional parameters (OFFDR1C, OFFDR1H) are calibrated by Melexis to compensate for the offset temperature drift caused by the Hall element (before the variable gain amplifier). These parameters should not be adjusted on customer-side.

Noise filter (NOISEFILT)

Setting this bit to 1 enables the noise filter, reducing noise and increasing response time.

Identification code (ID)

48 bits programmable identification code.

Self diagnostic

The MLX91209 provides self diagnostic features to detect internal memory errors and over- / under-voltage conditions. These features increase the robustness of the IC functionality, as they prevent erroneous output signal in case of internal or external failure modes.

Error	Action	Effect on Output	Remarks
Calibration Data CRC Error (at power up and in normal working mode)	Fault mode	High Impedance mode	Pull down resistive load => Diag Low Pull up resistive load => Diag High
Power On Delay		High Impedance mode	Max 5ms in high impedance followed by settling
Undervoltage Mode	IC reset	High Impedance mode	300mV Hysteresis (typical)
Overvoltage Detection	IC reset	High Impedance mode	100mV Hysteresis (typical)

Table 8: Self diagnostic

Recommended Application Diagrams

Resistor and capacitor values

Part	Description	Value	Unit
C1	Supply capacitor, EMI, ESD	100	nF
C2	Decoupling, EMI, ESD	2-10 ⁽¹⁾	nF
R1	Pull up or pull down resistor	6 - 100	kΩ

Table 10: Resistor and capacitor values

(1) 10nF is recommended for better EMC and ESD performance.

Pull down resistor for diagnostic low

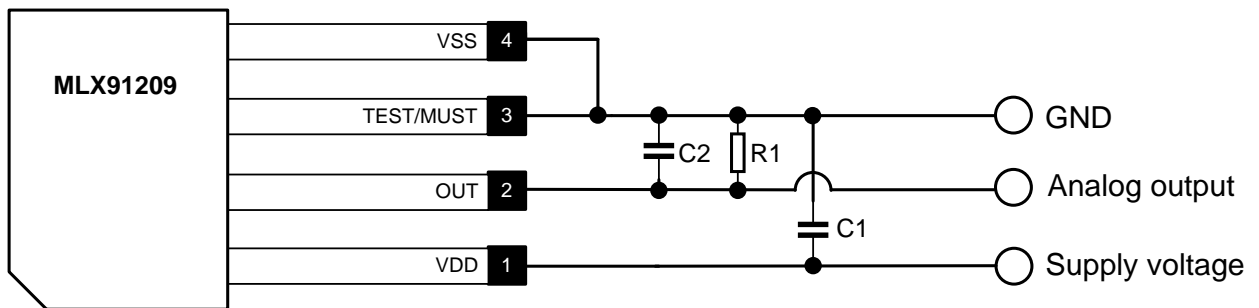

Figure 3: Diagnostic low

Pull up resistor for diagnostic high

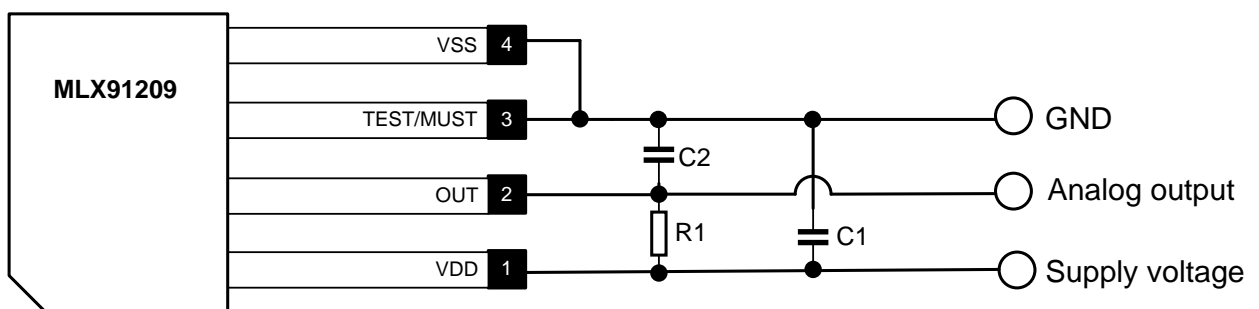

Figure 4: Diagnostic high

Typical performance

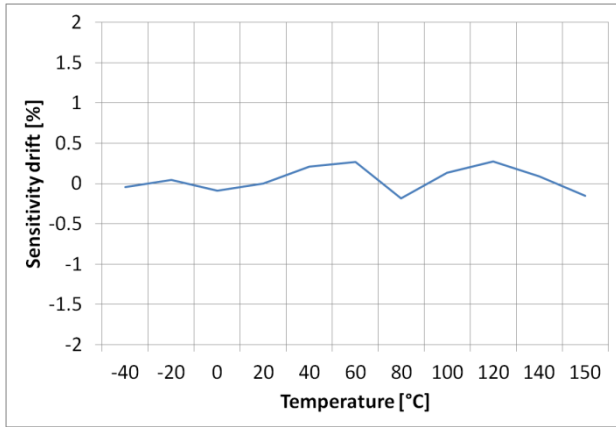

Figure 5: Thermal sensitivity drift.

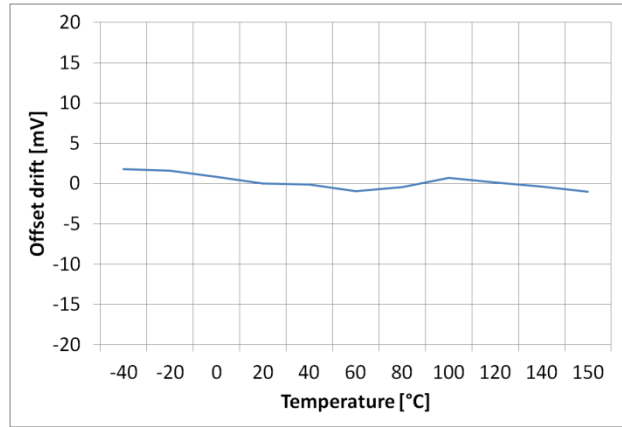

Figure 6: Thermal offset drift

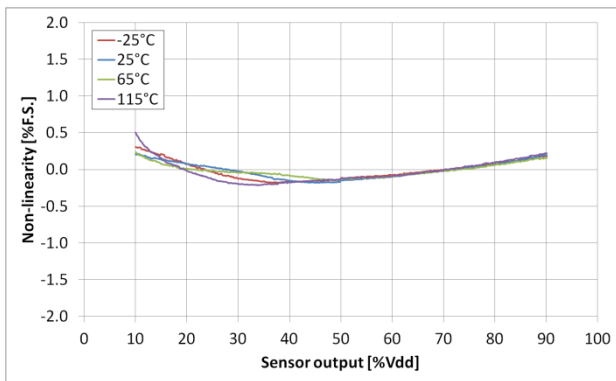

Figure 7: Non-linearity over temperature

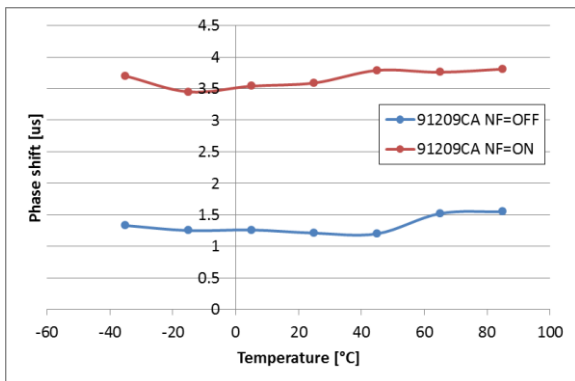

Figure 8: Phase shift over temperature.

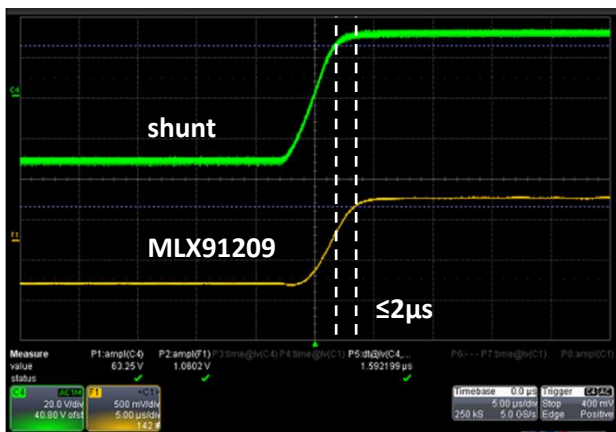

Figure 9: Response time with noise filter OFF.

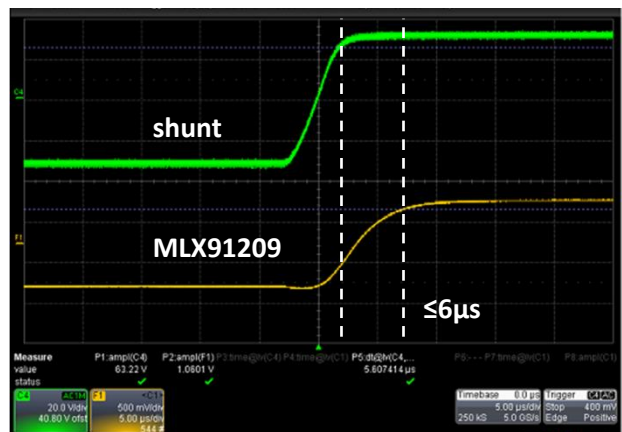

Figure 10: Response time with noise filter ON.

Standard information regarding manufacturability of Melexis products with different soldering processes

Our products are classified and qualified regarding soldering technology, solderability and moisture sensitivity level according to following test methods:

Reflow Soldering SMD's (Surface Mount Devices)

- IPC/JEDEC J-STD-020
Moisture/Reflow Sensitivity Classification for Nonhermetic Solid State Surface Mount Devices (classification reflow profiles according to table 5-2)
- EIA/JEDEC JESD22-A113
Preconditioning of Nonhermetic Surface Mount Devices Prior to Reliability Testing (reflow profiles according to table 2)

Wave Soldering SMD's (Surface Mount Devices) and THD's (Through Hole Devices)

- EN60749-20
Resistance of plastic- encapsulated SMD's to combined effect of moisture and soldering heat
- EIA/JEDEC JESD22-B106 and EN60749-15
Resistance to soldering temperature for through-hole mounted devices

Iron Soldering THD's (Through Hole Devices)

- EN60749-15
Resistance to soldering temperature for through-hole mounted devices

Solderability SMD's (Surface Mount Devices) and THD's (Through Hole Devices)

- EIA/JEDEC JESD22-B102 and EN60749-21
Solderability

For all soldering technologies deviating from above mentioned standard conditions (regarding peak temperature, temperature gradient, temperature profile, etc.) additional classification and qualification tests have to be agreed upon with Melexis.

The application of Wave Soldering for SMD's is allowed only after consulting Melexis regarding assurance of adhesive strength between device and board.

Melexis recommends reviewing on our web site the General Guidelines [soldering recommendation](http://www.melexis.com/Quality_soldering.aspx) (http://www.melexis.com/Quality_soldering.aspx) as well as [trim&form recommendations](http://www.melexis.com/Assets/Trim-and-form-recommendations-5565.aspx) (<http://www.melexis.com/Assets/Trim-and-form-recommendations-5565.aspx>).

Melexis is contributing to global environmental conservation by promoting **lead free** solutions. For more information on qualifications of **RoHS** compliant products (RoHS = European directive on the Restriction Of the use of certain Hazardous Substances) please visit the quality page on our website: <http://www.melexis.com/quality.aspx>

ESD Precautions

Electronic semiconductor products are sensitive to Electro Static Discharge (ESD).

Always observe Electro Static Discharge control procedures whenever handling semiconductor products.

FAQ

For which current range can the sensor be used?

The magnetic field [mT] seen by the sensor for a given current [A] depends on the design of the enclosing ferromagnetic core (air gap size, material type, etc.). Therefore, the current range is not limited by the sensor itself, but rather by the magnetic properties of the core (saturation, hysteresis, etc.).

What is the default sensitivity of the sensor?

The sensor is factory calibrated for a typical sensitivity of 50mV/mT.

How can I program the sensor?

The sensor uses a 3 wires communication protocol (Vdd, Vss and Out) and can be programmed using Melexis Universal Programmer (PTC-04), with the dedicated daughter board PTC04-DB-HALL05. For more information, please visit <http://www.melexis.com/Hardware-and-Software-Tools/Programming-Tools/PTC-04-568.aspx>.

Package Information

VA / SIP 4L (single in-line package)

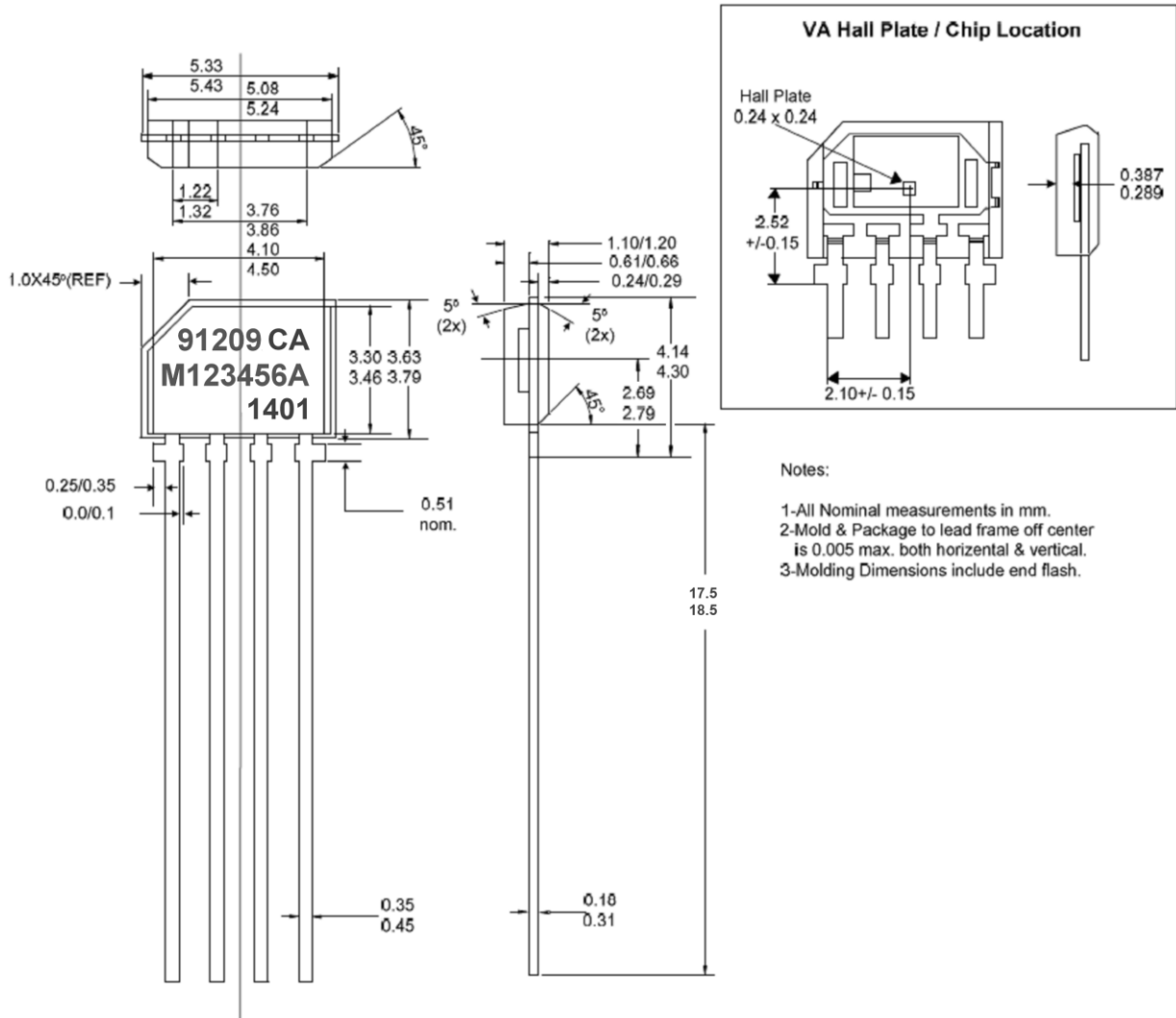

Figure 11: VA / SIP 4L (single in-line package) dimensions

Disclaimer

Devices sold by Melexis are covered by the warranty and patent indemnification provisions appearing in its Term of Sale. Melexis makes no warranty, express, statutory, implied, or by description regarding the information set forth herein or regarding the freedom of the described devices from patent infringement. Melexis reserves the right to change specifications and prices at any time and without notice. Therefore, prior to designing this product into a system, it is necessary to check with Melexis for current information. This product is intended for use in normal commercial applications. Applications requiring extended temperature range, unusual environmental requirements, or high reliability applications, such as military, medical life-support or life-sustaining equipment are specifically not recommended without additional processing by Melexis for each application.

The information furnished by Melexis is believed to be correct and accurate. However, Melexis shall not be liable to recipient or any third party for any damages, including but not limited to personal injury, property damage, loss of profits, loss of use, interrupt of business or indirect, special incidental or consequential damages, of any kind, in connection with or arising out of the furnishing, performance or use of the technical data herein. No obligation or liability to recipient or any third party shall arise or flow out of Melexis' rendering of technical or other services.

© 2012 Melexis NV. All rights reserved.

Contact Information

For the latest version of this document, go to our website at
www.melexis.com

Or for additional information contact Melexis Direct:

Europe, Africa, Asia:

Phone: +32 1367 0495
E-mail: sales_europe@melexis.com

America:

Phone: +1 248 306 5400
E-mail: sales_usa@melexis.com

ISO/TS 16949 and ISO14001 Certified