

## FEATURES

- Low drain-source ON resistance
- High forward transfer admittance
- Repetitive avalanche ratings
- Simple drive requirements
- Ease of paralleling

## APPLICATIONS

- Switching power supplies
- Motor controls
- Inverters and choppers
- Audio amplifiers and energy pulse circuits

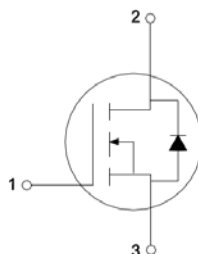

1.GATE  
2.DRAIN  
3.SOURCE

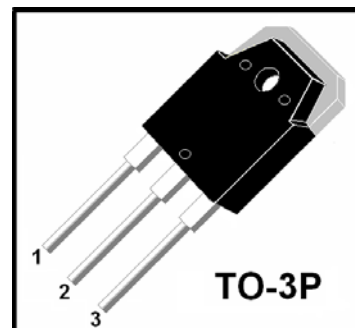

## ABSOLUTE MAXIMUM RATINGS

$T_C=25^{\circ}\text{C}$  unless otherwise specified

Symbol	Parameter	Test Conditions	Values	Unit
$V_{DS}$	Drain - Source Voltage	$T_J=25^{\circ}\text{C}$	500	V
$V_{GS}$	Gate - Source Voltage		$\pm 20$	V
$I_D$	Continuous Drain Current	$T_C=25^{\circ}\text{C}$	22	A
		$T_C=100^{\circ}\text{C}$	15	A
$I_{DM}$	Pulsed Drain Current	Limited by $T_{jmax}$	60	A
$P_D$	Maximum Power Dissipation		150	W
$E_{AS}$	Single Pulse Avalanche Energy		800	mJ
$I_{AR}$	Avalanche Current		22	A
$E_{AR}$	Repetitive Avalanche Energy		25	mJ
$T_J$	Operating Junction		150	$^{\circ}\text{C}$
$T_{STG}$	Storage Temperature Range		-55~150	$^{\circ}\text{C}$
Weight			12	g

## THERMAL CHARACTERISTICS

$T_C=25^{\circ}\text{C}$  unless otherwise specified

Symbol	Parameter	Test Conditions	Values	Unit
$R_{th(ch-c)}$	Thermal resistance,channel to case		0.83	$^{\circ}\text{C}/\text{W}$
$R_{th(ch-a)}$	Thermal resistance,channel to ambient		40	$^{\circ}\text{C}/\text{W}$

## MM15N050P

### ELECTRICAL CHARACTERISTICS

$T_C=25^\circ\text{C}$  unless otherwise specified

Symbol	Parameter	Test Conditions	Min.	Typ.	Max.	Unit
$V_{(BR)DSS}$	Drain-Source Breakdown Voltage	$V_{GS}=0V, I_D=250\mu A$	500			V
$R_{DS(ON)}$	Drain-Source ON Resistance	$V_{GS}=10V, I_D=7A$		0.27		$\Omega$
		$V_{GS}=10V, I_D=15A$		0.28		$\Omega$
$V_{GS(th)}$	Gate Threshold Voltage	$V_{GS}=V_{DS}, I_D=250\mu A$	2	3	4	V
$I_{GSS}$	Gate Leakage Current	$V_{DS}=0V, V_{GS}=\pm 20V$	-200		200	nA
$I_{DSS}$	Zero Gate Voltage Drain Current	$V_{DS}=500V, V_{GS}=0V$			100	$\mu A$
$Q_g$	Total Gate Charge	$V_{DD}=300V, I_D=15A, V_{GS}=10V$		99		nC
$Q_{gs}$	Gate-Source Charge			35		nC
$Q_{gd}$	Gate-Drain Charge			32		nC
$g_{fs}$	Forward Transconductance	$V_{DS}=50V, I_D=7A$		12		S
$C_{iss}$	Input Capacitance	$V_{DS}=25V, V_{GS}=0V, f=1\text{MHz}$		4400		pF
$C_{oss}$	Output Capacitance			900		pF
$C_{rss}$	Reverse Transfer Capacitance			270		pF
$t_{d(on)}$	Turn - on Delay Time	$V_{DD}=300V, I_D=15A,$ $R_G=7.5\Omega,$ $V_{GS}=10V,$ $R_L=20\Omega$	$T_J=25^\circ\text{C}$	30		ns
			$T_J=125^\circ\text{C}$	32		ns
$t_r$	Rise Time		$T_J=25^\circ\text{C}$	35		ns
			$T_J=125^\circ\text{C}$	38		ns
$t_{d(off)}$	Turn - off Delay Time		$T_J=25^\circ\text{C}$	100		ns
			$T_J=125^\circ\text{C}$	105		ns
$t_f$	Fall Time		$T_J=25^\circ\text{C}$	28		ns
			$T_J=125^\circ\text{C}$	35		ns

### Source-Drain RATINGS AND CHARACTERISTICS

$T_C=25^\circ\text{C}$  unless otherwise specified

Symbol	Parameter	Test Conditions	Min.	Typ.	Max.	Unit
$I_{SD}$	Continuous Source-Drain Current				15	A
$I_{SDM}$	Pulse Source-Drain Current				60	A
$V_{SD}$	Source-Drain Voltage	$I_{SD}=15A, V_{GS}=0V, T_J=25^\circ\text{C}$		0.85	1.6	V
$t_{rr}$	Reverse Recovery Time	$I_{SD}=15A, di_{SD}/dt=-100A/\mu s$ $T_J=25^\circ\text{C}$		420		ns
$I_{RRM}$	Max. Reverse Recovery Current			18		A
$Q_{RRM}$	Max. Reverse Recovery Charge			4.3		$\mu C$

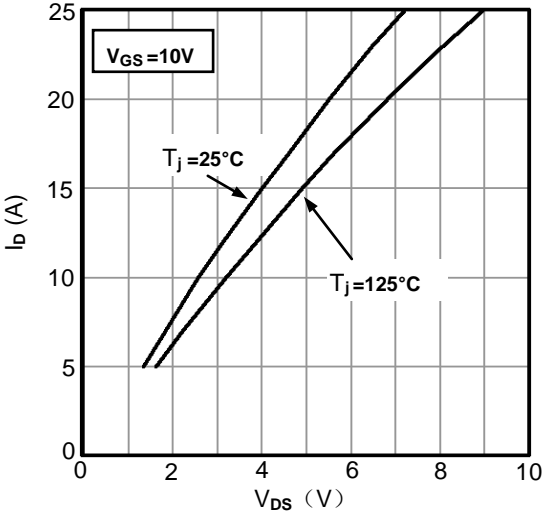

Figure1. Typical Output Characteristics

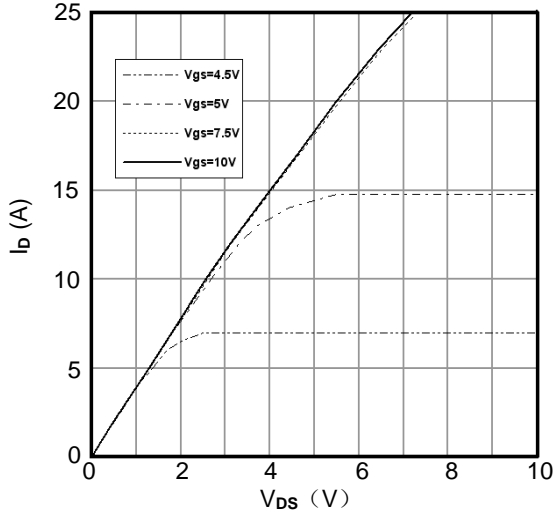

Figure2. Typical Output Characteristics

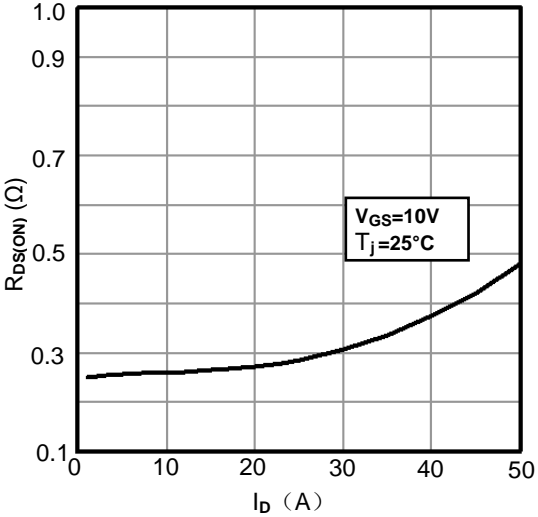

Figure3. Drain-Source ON Resistance vs. I\_D

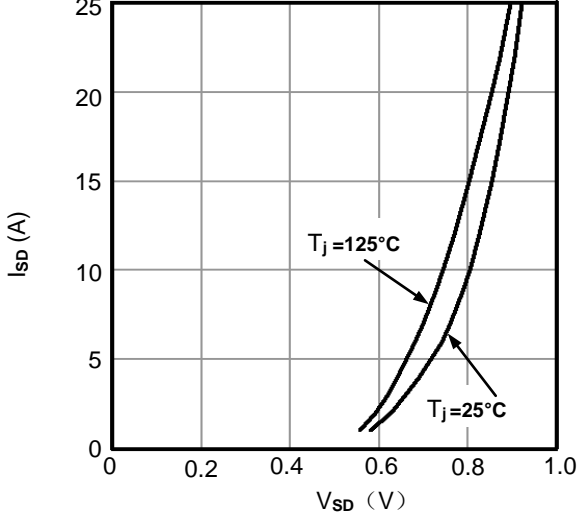

Figure4. Source-Drain Voltage

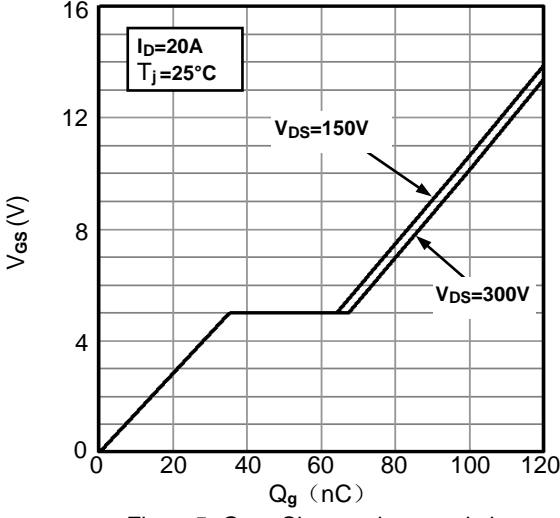

Figure5. Gate Charge characteristics

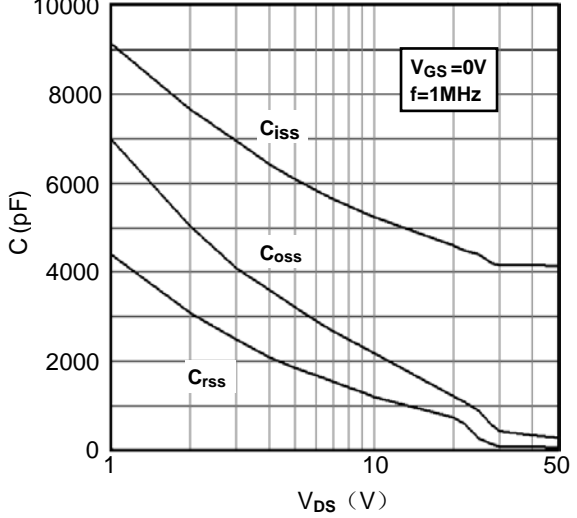

Figure6. Typical Capacitances vs. V\_DS

**MM15N050P**

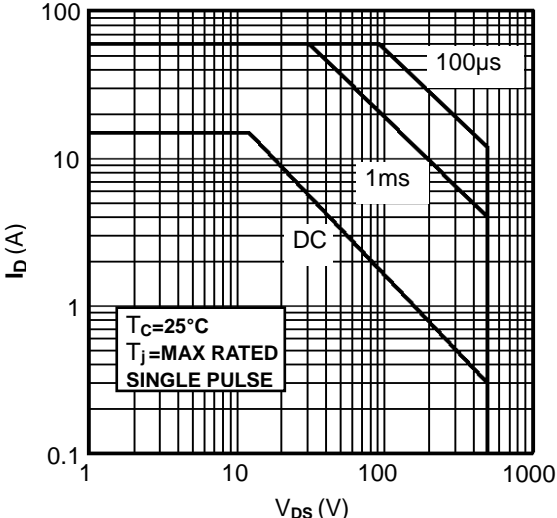

Figure 7. Forward Bias Safe Operating Area

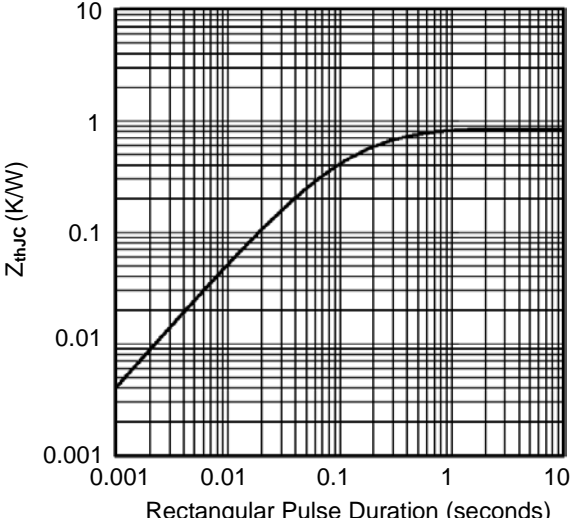

Figure 8. Transient Thermal Impedance

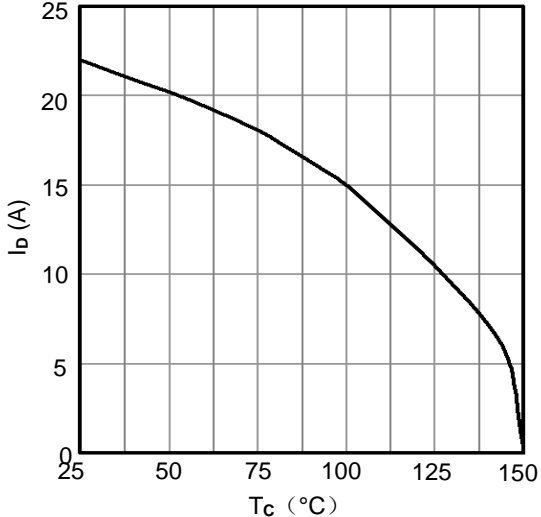

Figure 9. Maximum Continuous Drain Current vs. Case Temperature

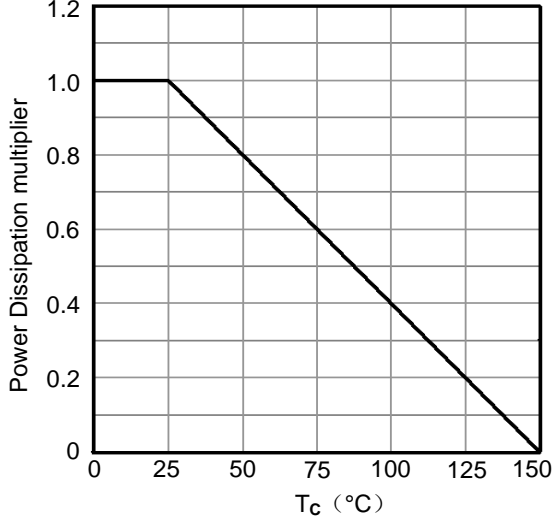

Figure 10. Normalized Power Dissipation vs. Case Temperature

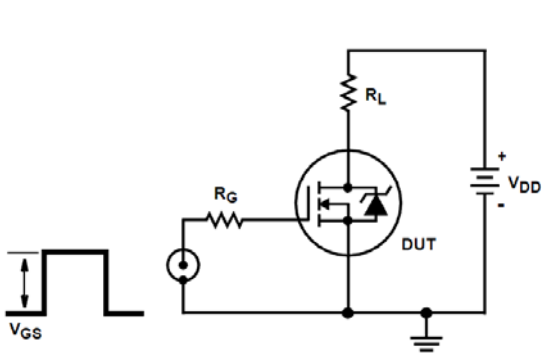

Figure 11. Switching Time Test Circuit

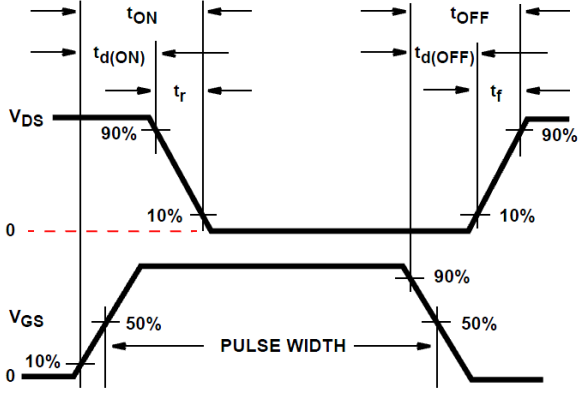

Figure 12. Resistive Switching Waveforms

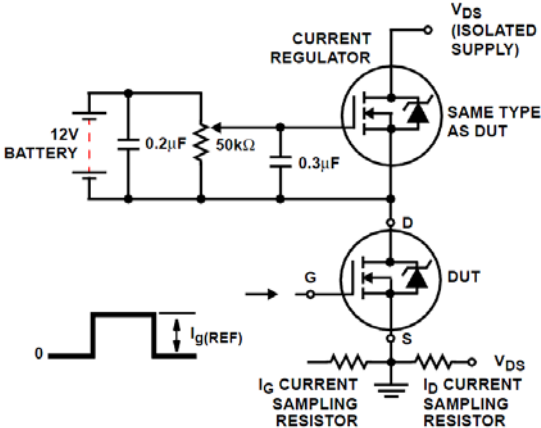

Figure13. Gate Charge Test Circuit

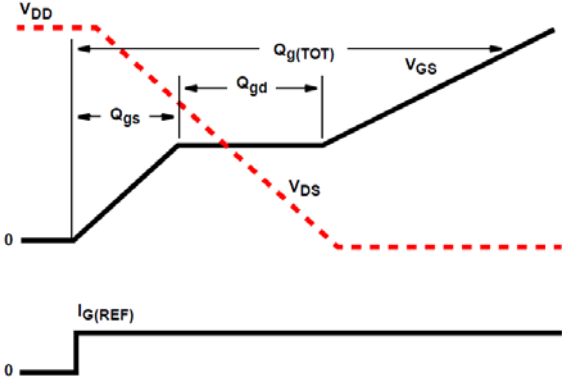
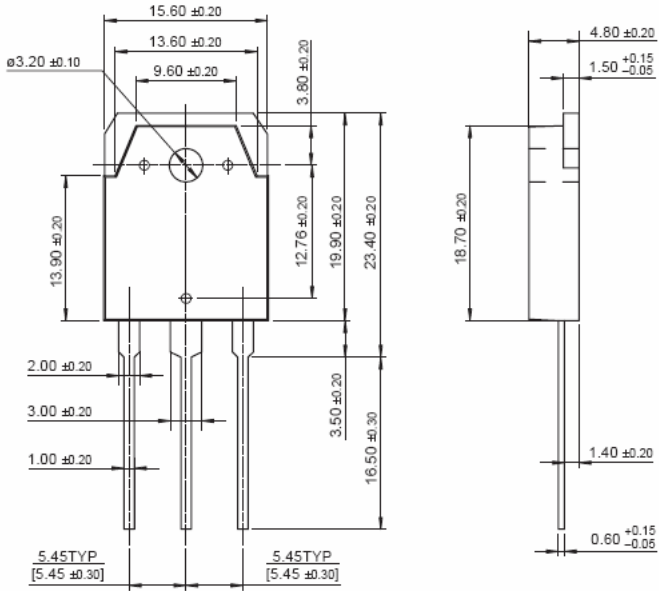

Figure14. Gate Charge Waveforms



Dimensions (mm)  
Figure15. Package Outline