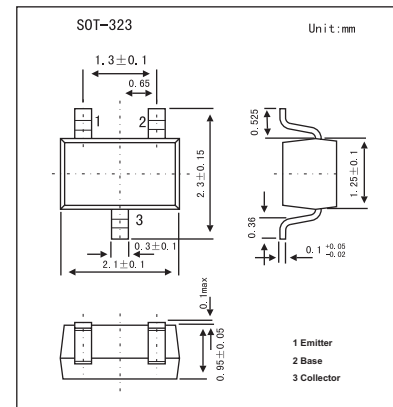
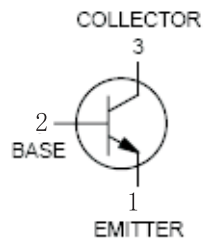

General Purpose Transistor

MMBT3906W

■ Features

- General purpose transistor.
- Pb-Free package is available.

■ Absolute Maximum Ratings $T_a = 25^\circ\text{C}$

Parameter	Symbol	Rating	Unit
Collector-emitter voltage	V_{CEO}	-40	V
Collector-base voltage	V_{CBO}	-40	V
Emitter-base voltage	V_{EBO}	-5	V
Collector current	I_C	-200	mA
Total Device Dissipation FR-5 Board	P_D	150	mW
Thermal Resistance, Junction-to-Ambient	$R_{\theta JA}$	833	$^\circ\text{C}/\text{W}$
Junction temperature	T_j	150	$^\circ\text{C}$
Storage temperature	T_{stg}	-55 to +150	$^\circ\text{C}$

MMBT3906W

■ Electrical Characteristics Ta = 25°C

Parameter	Symbol	Testconditions	Min	Typ	Max	Unit
Collector-emitter breakdown voltage	$V_{(BR)CEO}$	$I_C = -1.0 \text{ mA}, I_B = 0$	-40			V
Collector-base breakdown voltage	$V_{(BR)CBO}$	$I_C = -10 \mu\text{A}, I_E = 0$	-40			V
Emitter-base breakdown voltage	$V_{(BR)EBO}$	$I_E = -10 \mu\text{A}, I_C = 0$	-5			V
Base cutoff current	I_{BL}	$V_{CE} = -30 \text{ V}, V_{EB} = -3.0 \text{ V}$			-50	nA
Collector cutoff current	I_{CEX}	$V_{CE} = -30 \text{ V}, V_{EB} = -3.0 \text{ V}$			-50	nA
DC current gain *	H_{FE}	$I_C = -0.1 \text{ mA}, V_{CE} = -1.0 \text{ V}$ $I_C = -1.0 \text{ mA}, V_{CE} = -1.0 \text{ V}$ $I_C = -10 \text{ mA}, V_{CE} = -1.0 \text{ V}$ $I_C = -50 \text{ mA}, V_{CE} = -1.0 \text{ V}$ $I_C = -100 \text{ mA}, V_{CE} = -1.0 \text{ V}$	60 80 100 60 30		300	
Collector-emitter saturation voltage *	$V_{CE(sat)}$	$I_C = -10 \text{ mA}, I_B = -1.0 \text{ mA}$ $I_C = -50 \text{ mA}, I_B = -5.0 \text{ mA}$			-0.25 -0.4	V
Base-emitter saturation voltage *	$V_{BE(sat)}$	$I_C = -10 \text{ mA}, I_B = -1.0 \text{ mA}$ $I_C = -50 \text{ mA}, I_B = -5.0 \text{ mA}$	-0.65		-0.85 -0.95	
Current-gain-bandwidth product	f_T	$I_C = -10 \text{ mA}, V_{CE} = -20 \text{ V}, f = 100 \text{ MHz}$	250			MHz
Output capacitance	C_{obo}	$V_{CB} = -5.0 \text{ V}, I_E = 0, f = 1.0 \text{ MHz}$			4.5	pF
Input capacitance	C_{ibo}	$V_{EB} = -0.5 \text{ V}, I_C = 0, f = 1.0 \text{ MHz}$			10	pF
Input impedance	h_{ie}	$V_{CE} = -10 \text{ V}, I_C = -1.0 \text{ mA}, f = 1.0 \text{ kHz}$	2.0		12	k Ω
Voltage feedback ratio	h_{re}	$V_{CE} = -10 \text{ V}, I_C = -1.0 \text{ mA}, f = 1.0 \text{ kHz}$	0.1		10	$\times 10^{-4}$
Small-signal current gain	h_{fe}	$V_{CE} = -10 \text{ V}, I_C = -1.0 \text{ mA}, f = 1.0 \text{ kHz}$	100		400	
Output admittance	h_{oe}	$V_{CE} = -10 \text{ V}, I_C = -1.0 \text{ mA}, f = 1.0 \text{ kHz}$	3.0		60	μmhos
Noise figure	NF	$V_{CE} = -5.0 \text{ V}, I_C = -100 \mu\text{A}, R_s = 1.0 \text{ k}\Omega, f = 1.0 \text{ kHz}$			4.0	dB
Delay time	t_d	$V_{CC} = -3.0 \text{ V}, V_{BE} = 0.5 \text{ V}$			35	ns
Rise time	t_r	$I_C = -10 \text{ mA}, I_{B1} = -1.0 \text{ mA}$			35	ns
Storage time	t_s	$V_{CC} = -3.0 \text{ V}, I_C = -10 \text{ mA}$			225	ns
Fall time	t_f	$I_{B1} = I_{B2} = -1.0 \text{ mA}$			75	ns

* Pulse test: pulse width $\leq 300 \mu\text{s}$, duty cycle $\leq 2.0\%$.

■ Marking

Marking	2A
---------	----