

High Voltage switching Diode

MMSD103

FEATURES

- Surface Mount Package Ideally Suited For Automatic Insertion
- For General Purpose Switching Applications

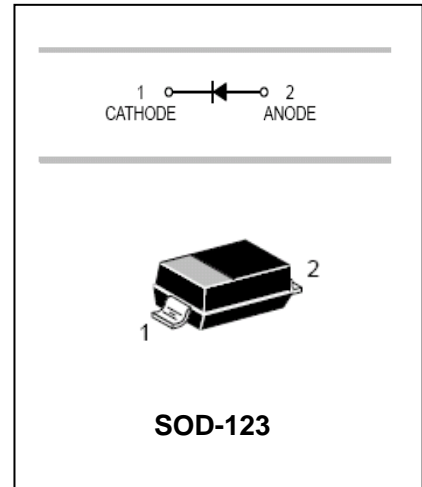

APPLICATIONS

- Surface mount fast switching diode

ORDERING INFORMATION

Type No.	Marking	Package Code
MMSD103	JS	SOD-123

MAXIMUM RATING @ Ta=25°C unless otherwise specified

Characteristic	Symbol	Value	Unit
Continuous reverse Voltage	V_R	250	V
Forward Continuous Current	I_F	200	mA
Peak Forward Surge Current	I_{FSM}	625	mA
Power Dissipation	P_d	400	mW
Thermal Resistance, Junction to case	$R_{\theta JL}$	174	°C/W
Thermal Resistance, Junction to Ambient	$R_{\theta JA}$	492	°C/W
Operating and Storage Temperature Range	T_j, T_{STG}	-55 to +150	°C

ELECTRICAL CHARACTERISTICS @ Ta=25°C unless otherwise specified

Characteristic	Symbol	Min	Max	Unit	Test Condition
Reverse Breakdown Voltage	$V_{(BR)R}$	250	-	V	$I_R=100\mu A$
Forward Voltage	V_F	-	1.0 1.25	V	$I_F=100mA$ $I_F=200mA$
Reverse Current	I_R	-	1 100	μA μA	$V_R=200V$ $V_R=200V, T_J=150^\circ C$
Diode Capacitance	C_D	-	5.0	pF	$V_R=0, f=1.0MHz$
Reverse Recovery Time	t_{rr}	-	50	ns	$I_F=I_R=30mA, R_L=100\Omega$



High Voltage switching Diode

MMSD103

TYPICAL CHARACTERISTICS @ $T_a=25^\circ\text{C}$ unless otherwise specified

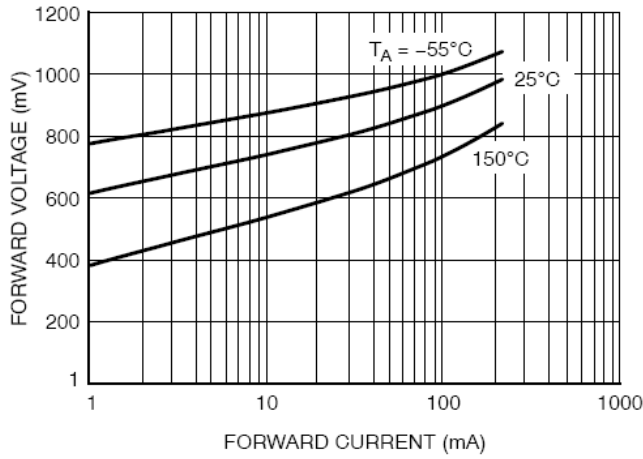

Figure 1. Forward Voltage

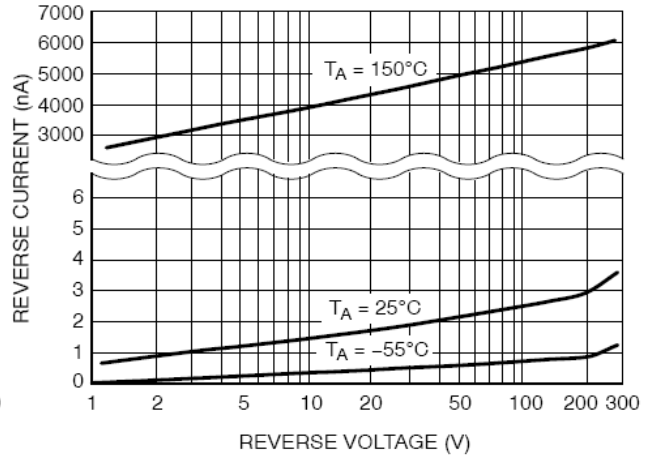

Figure 2. Reverse Leakage

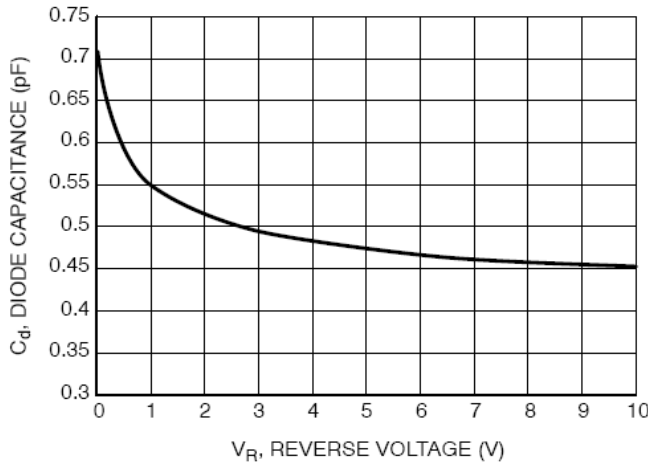

Figure 3. Diode Capacitance

High Voltage switching Diode

MMSD103

PACKAGE OUTLINE

Plastic surface mounted package

SOD-123

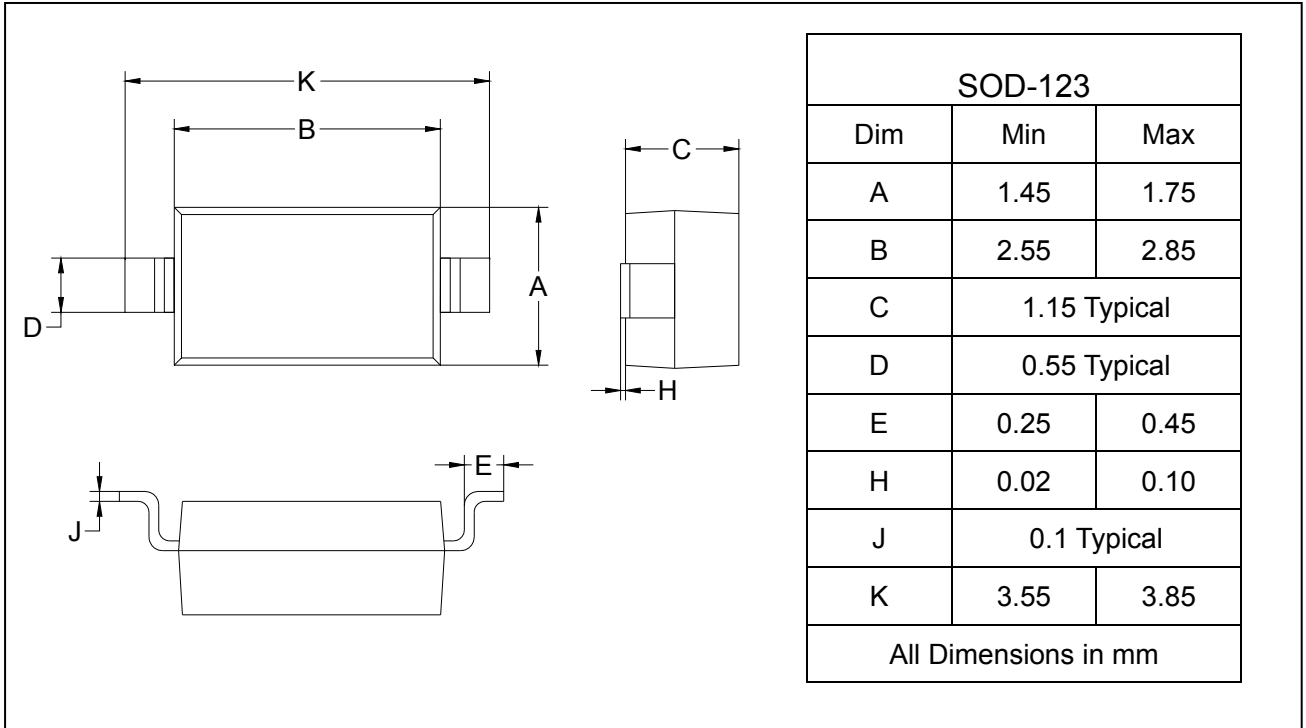

SOLDERING FOOTPRINT

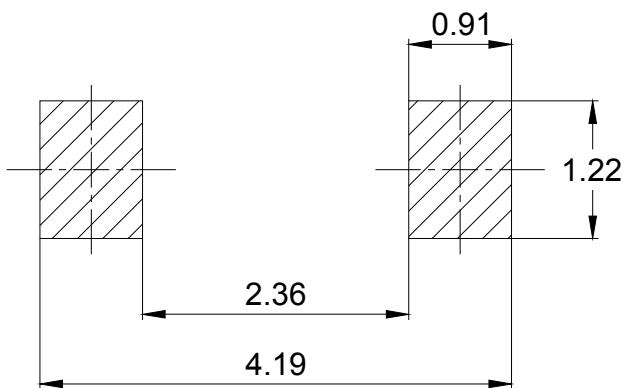

Unit: mm

PACKAGE INFORMATION

Device	Package	Shipping
MMSD103	SOD-123	3000/Tape&Reel