

# **PanaXSeries**

*TheOneToWatch for Constant Innovation-Making theFuture Come Alive*

MICROCOMPUTER

MN101C

MN101C49G/49H/49K/F49K/P49K

LSI User's Manual

Pub.No.21449-041E



PanaXSeries is a trademark of Matsushita Electric Industrial Co., Ltd.

The other corporation names, logotype and product names written in this book are trademarks or registered trademarks of their corresponding corporations.

## Request for your special attention and precautions in using the technical information and semiconductors described in this book

- (1) An export permit needs to be obtained from the competent authorities of the Japanese Government if any of the products or technologies described in this book and controlled under the "Foreign Exchange and Foreign Trade Law" is to be exported or taken out of Japan.
- (2) The technical information described in this book is limited to showing representative characteristics and applied circuits examples of the products. It neither warrants non-infringement of intellectual property right or any other rights owned by our company or a third party, nor grants any license.
- (3) We are not liable for the infringement of rights owned by a third party arising out of the use of the product or technologies as described in this book.
- (4) The products described in this book are intended to be used for standard applications or general electronic equipment (such as office equipment, communications equipment, measuring instruments and household appliances).  
Consult our sales staff in advance for information on the following applications:
  - Special applications (such as for airplanes, aerospace, automobiles, traffic control equipment, combustion equipment, life support systems and safety devices) in which exceptional quality and reliability are required, or if the failure or malfunction of the products may directly jeopardize life or harm the human body.
  - Any applications other than the standard applications intended.
- (5) The products and product specifications described in this book are subject to change without notice for modification and/or improvement. At the final stage of your design, purchasing, or use of the products, therefore, ask for the most up-to-date Product Standards in advance to make sure that the latest specifications satisfy your requirements.
- (6) When designing your equipment, comply with the guaranteed values, in particular those of maximum rating, the range of operating power supply voltage, and heat radiation characteristics. Otherwise, we will not be liable for any defect which may arise later in your equipment.  
Even when the products are used within the guaranteed values, take into the consideration of incidence of break down and failure mode, possible to occur to semiconductor products. Measures on the systems such as redundant design, arresting the spread of fire or preventing glitch are recommended in order to prevent physical injury, fire, social damages, for example, by using the products.
- (7) When using products for which damp-proof packing is required, observe the conditions (including shelf life and amount of time let standing of unsealed items) agreed upon when specification sheets are individually exchanged.
- (8) This book may be not reprinted or reproduced whether wholly or partially, without the prior written permission of Matsushita Electric Industrial Co., Ltd.

If you have any inquiries or questions about this book or our semiconductors, please contact one of our sales offices listed at the back of this book.

# About This Manual

MN101C66 series offers a choice of masked ROM version. We're now developing user-programmable Flash EPROM version.

## ■Organization

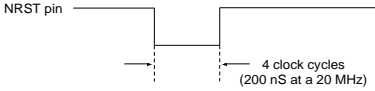


In this LSI manual, this LSI functions are presented in the following order : overview, basic CPU functions, interrupt functions, port functions, timer functions, serial functions, and other peripheral hardware functions.

Each section contains overview of function, block diagram, control register, operation, and setting example.

## Manual Configuration

Each section of this manual consists of a title, summary, main text, key information, precautions and warnings, and references.

The layout and definition of each section are shown below.

Subtitle	<p>Chapter 2 Basic CPU</p> <h3>2-8 Reset</h3> <h4>2-8-1 Reset operation</h4> <p>The CPU contents are reset and registers are initialized when the NRST pin (P.27) is pulled to low.</p> <p>■ Initiating a Reset There are two methods to initiate a reset.</p> <p>(1) Drive the NRST pin low for at least four clock cycles. NRST pin should be holded "low" for more than 4 clock cycles (200 nS at a 20 MHz).</p>  <p><b>Figure 2-8-1 Minimum Reset Pulse Width</b></p> <p>(2) Setting the P2OUT7 flag of the P2OUT register to "0" outputs low level at P27 (NRST) pin. And transferring to reset by program (software reset) can be executed. If the internal LSI is reset and register is initiated, the P2OUT7 flag becomes "1" and reset is released.</p> <p>[ Chapter 4, 4-4-2. Registers ]</p> <div data-bbox="517 1290 1102 1357"> <p> On this LSI, the starting mode is NORMAL mode that high oscillation is the base clock.</p> </div> <div data-bbox="517 1384 1102 1451"> <p> When the power voltage low circuit is connected to NRST pin, circuit that gives pulse for enough low level time at sudden unconnected. And reset can be generated even if its pulse is low level as the oscillation clock is under 4 clocks, take notice of noise.</p> </div> <p>II - 44 Reset</p>	Summary
Sub-subtitle		Introduction to the
The smallest block in this manual.		section.
Main text		References
Key information Important information from the text.		References for the main text.
	Precautions and warnings	
	Precautions are listed in case. Be sure to read these of lost functionality or damage.	

## ■ Finding Desired Information

This manual provides three methods for finding desired information quickly and easily.

- (1) Consult the index at the front of the manual to locate the beginning of each section.
- (2) Consult the table of contents at the front of the manual to locate desired titles.
- (3) Chapter names are located at the top outer corner of each page, and section titles are located at the bottom outer corner of each page.

## ■ Related Manuals

Note that the following related documents are available.

"MN101C Series LSI user's Manual"

<Describes the device hardware>

"MN101C Series Instruction Manual"

<Describes the instruction set.>

"MN101C Series C Compiler User's Manual: Usage Guide"

<Describes the installation, the commands, and options of the C Compiler.>

"MN101C Series C Compiler User's Manual: Language Description"

<Describes the syntax of the C Compiler.>

"MN101C Series C Compiler User's Manual: Library Reference"

<Describes the standard library of the C Compiler.>

"MN101C Series Cross-assembler User's Manual"

<Describes the assembler syntax and notation.>

"MN101C Series C Source Code Debugger User's Manual"

<Describes the use of C source code debugger.>

"MN101C Series PanaX Series Installation Manual"

<Describes the installation of C compiler, cross-assembler and C source code debugger and the procedure for bringing up the in-circuit emulator.>

Chapter 1	Overview	1
Chapter 2	CPU Basics	2
Chapter 3	Interrupts	3
Chapter 4	I/O Ports	4
Chapter 5	Prescaler	5
Chapter 6	8-bit Timers	6
Chapter 7	16-bit Timer	7
Chapter 8	Time Base Timer / 8-bit Free-running Timer	8
Chapter 9	Watchdog Timer	9
Chapter 10	Buzzer	10
Chapter 11	Serial Interface 0	11
Chapter 12	Serial Interface 1	12
Chapter 13	Serial Interface 2	13
Chapter 14	Serial Interface 3	14
Chapter 15	Automatic Transfer Controller	15
Chapter 16	A/D Converter	16
Chapter 17	D/A Converter	17
Chapter 18	AC Timing Variable Functions	18
Chapter 19	Appendices	19
Chapter 20	Flash EEPROM	20

# Contents

## Chapter 1 Overview

1-1	Overview .....	I - 2
1-1-1	Overview .....	I - 2
1-1-2	Product Summary .....	I - 2
1-2	Hardware Functions .....	I - 3
1-3	Pin Description .....	I - 8
1-3-1	Pin Configuration .....	I - 8
1-3-2	Pin Specification .....	I - 9
1-3-3	Pin Functions .....	I - 11
1-4	Block Diagram .....	I - 18
1-4-1	Block Diagram .....	I - 18
1-5	Electrical Characteristics .....	I - 19
1-5-1	Absolute Maximum Ratings .....	I - 19
1-5-2	Operating Conditions .....	I - 20
1-5-3	DC Characteristics .....	I - 23
1-5-4	A/D Converter Characteristics .....	I - 28
1-5-5	D/A Converter Characteristics .....	I - 29
1-6	Package Dimension .....	I - 30
1-7	Precautions .....	I - 32
1-7-1	General Usage .....	I - 32
1-7-2	Unused Pins .....	I - 33
1-7-3	Power Supply .....	I - 35
1-7-4	Power Supply Circuit .....	I - 36

## Chapter 2 CPU Basics

2-1	Overview .....	II - 2
2-1-1	Block Diagram .....	II - 3
2-1-2	CPU Control Registers .....	II - 4
2-1-3	Instruction Execution Controller .....	II - 5
2-1-4	Pipeline Process .....	II - 6
2-1-5	Registers for Address .....	II - 6
2-1-6	Registers for Data .....	II - 7
2-1-7	Processor Status Word .....	II - 8
2-1-8	Addressing Modes .....	II - 10
2-2	Memory Space .....	II - 12
2-2-1	Memory Mode .....	II - 12
2-2-2	Single-chip Mode .....	II - 13
2-2-3	Memory Expansion Mode .....	II - 14



2-2-4	Processor Mode .....	II - 15
2-2-5	Special Function Registers .....	II - 16
2-3	Bus Interface .....	II - 17
2-3-1	Bus Controller .....	II - 17
2-3-2	Control Registers .....	II - 18
2-3-3	Fixed Wait Cycle Mode .....	II - 20
2-3-4	Handshake Mode .....	II - 20
2-3-5	External Memory Connection Example .....	II - 22
2-4	Standby Function .....	II - 23
2-4-1	Overview .....	II - 23
2-4-2	CPU Mode Control Register .....	II - 25
2-4-3	Transition between SLOW and NORMAL .....	II - 26
2-4-4	Transition to STANDBY Modes .....	II - 27
2-5	Clock Switching .....	II - 29
2-6	Bank Function .....	II - 31
2-6-1	Overview .....	II - 31
2-6-2	Bank Setting .....	II - 31
2-6-3	Bank Memory Space .....	II - 33
2-7	ROM Correction .....	II - 36
2-7-1	Overview .....	II - 36
2-7-2	Correction Sequence .....	II - 36
2-7-3	ROM Correction Control Register .....	II - 38
2-7-4	ROM Correction Setup Example .....	II - 41
2-8	Reset .....	II - 44
2-8-1	Reset Operation .....	II - 44
2-8-2	Oscillation Stabilization Wait Time .....	II - 46

## Chapter 3 Interrupts

3-1	Overview .....	III - 2
3-1-1	Functions .....	III - 3
3-1-2	Block Diagram .....	III - 4
3-1-3	Operation .....	III - 5
3-1-4	Interrupt Flag Setup .....	III - 14
3-2	Control Registers .....	III - 15
3-2-1	Registers List .....	III - 15
3-2-2	Interrupt Control Registers .....	III - 16
3-3	External Interrupts .....	III - 40
3-3-1	Overview .....	III - 40
3-3-2	Block Diagram .....	III - 41
3-3-3	Control Registers .....	III - 44
3-3-4	Programmable Active Edge Interrupt .....	III - 48
3-3-5	Both Edges Interrupt .....	III - 50

3-3-6	Key Input Interrupt .....	III - 51
3-3-7	Noise Filter .....	III - 53
3-3-8	AC Zero-Cross Detector .....	III - 56

## Chapter 4 I/O Ports

4-1	Overview .....	IV - 2
4-1-1	I/O Port Diagram .....	IV - 2
4-1-2	I/O Port Status at Reset .....	IV - 3
4-1-3	Control Registers .....	IV - 5
4-2	Port 0 .....	IV - 7
4-2-1	Description .....	IV - 7
4-2-2	Registers .....	IV - 8
4-2-3	Block Diagram .....	IV - 9
4-3	Port 1 .....	IV - 13
4-3-1	Description .....	IV - 13
4-3-2	Registers .....	IV - 14
4-3-3	Block Diagram .....	IV - 17
4-4	Port 2 .....	IV - 19
4-4-1	Description .....	IV - 19
4-4-2	Registers .....	IV - 20
4-4-3	Block Diagram .....	IV - 21
4-5	Port 3 .....	IV - 22
4-5-1	Description .....	IV - 22
4-5-2	Registers .....	IV - 23
4-5-3	Block Diagram .....	IV - 24
4-6	Port 4 .....	IV - 28
4-6-1	Description .....	IV - 28
4-6-2	Registers .....	IV - 29
4-6-3	Block Diagram .....	IV - 31
4-7	Port 5 .....	IV - 32
4-7-1	Description .....	IV - 32
4-7-2	Registers .....	IV - 33
4-7-3	Block Diagram .....	IV - 35
4-8	Port 6 .....	IV - 36
4-8-1	Description .....	IV - 36
4-8-2	Registers .....	IV - 37
4-8-3	Block Diagram .....	IV - 38
4-9	Port 7 .....	IV - 39
4-9-1	Description .....	IV - 39
4-9-2	Registers .....	IV - 40

4-9-3	Block Diagram .....	IV - 42
4-10	Port 8.....	IV - 43
4-10-1	Description .....	IV - 43
4-10-2	Registers .....	IV - 44
4-10-3	Block Diagram .....	IV - 45
4-11	Port A .....	IV - 46
4-11-1	Description .....	IV - 46
4-11-2	Registers .....	IV - 47
4-11-3	Block Diagram .....	IV - 49
4-12	Port C .....	IV - 50
4-12-1	Description .....	IV - 50
4-12-2	Registers .....	IV - 51
4-12-3	Block Diagram .....	IV - 52
4-13	Port D .....	IV - 53
4-13-1	Description .....	IV - 53
4-13-2	Registers .....	IV - 54
4-13-3	Block Diagram .....	IV - 56
4-14	Real Time Output Control (Port 1) .....	IV - 57
4-14-1	Registers .....	IV - 57
4-14-2	Operation .....	IV - 58
4-15	Synchronous Output (Port D) .....	IV - 60
4-15-1	Block Diagram .....	IV - 60
4-15-2	Registers .....	IV - 61
4-15-3	Operation .....	IV - 62
4-15-4	Setup Example .....	IV - 64

## Chapter 5 Prescaler

5-1	Overview .....	V - 2
5-1-1	Peripheral Functions .....	V - 3
5-1-2	Block Diagram .....	V - 4
5-2	Control Registers .....	V - 5
5-2-1	Registers List .....	V - 5
5-2-2	Control Registers .....	V - 6
5-3	Operation .....	V - 12
5-3-1	Operation .....	V - 12
5-3-2	Setup Example .....	V - 13

## Chapter 6 8-bit Timers

6-1	Overview .....	VI - 2
6-1-1	Functions .....	VI - 2
6-1-2	Block Diagram .....	VI - 3

6-2	Control Registers .....	VI - 7
6-2-1	Registers .....	VI - 7
6-2-2	Programmable Timer Registers .....	VI - 9
6-2-3	Timer Mode Registers .....	VI - 11
6-3	8-bit Timer Count .....	VI - 17
6-3-1	Operation .....	VI - 17
6-3-2	Setup Example .....	VI - 19
6-4	8-bit Event Count .....	VI - 21
6-4-1	Operation .....	VI - 21
6-4-2	Setup Example .....	VI - 23
6-5	8-bit Timer Pulse Output .....	VI - 25
6-5-1	Operation .....	VI - 25
6-5-2	Setup Example .....	VI - 26
6-6	8-bit PWM Output .....	VI - 28
6-6-1	Operation .....	VI - 28
6-6-2	Setup Example .....	VI - 30
6-7	8-bit Timer Synchronous Output .....	VI - 32
6-7-1	Operation .....	VI - 32
6-7-2	Setup Example .....	VI - 33
6-8	Serial Interface Transfer Clock Output .....	VI - 35
6-8-1	Operation .....	VI - 35
6-8-2	Setup Example .....	VI - 36
6-9	Simple Pulse Width Measurement .....	VI - 38
6-9-1	Operation .....	VI - 38
6-9-2	Setup Example .....	VI - 39
6-10	Cascade Connection .....	VI - 41
6-10-1	Operation .....	VI - 41
6-10-2	Setup Example .....	VI - 43
6-11	Remote Control Carrier Output .....	VI - 45
6-11-1	Operation .....	VI - 45
6-11-2	Setup Example .....	VI - 46

## Chapter 7 16-bit Timer

7-1	Overview .....	VII - 2
7-1-1	Functions .....	VII - 2
7-1-2	Block Diagram .....	VII - 3
7-2	Control Registers .....	VII - 4
7-2-1	Registers .....	VII - 4
7-2-2	Programmable Timer Registers .....	VII - 5
7-2-3	Timer Mode Registers .....	VII - 8

7-3	16-bit Timer Count .....	VII - 10
7-3-1	Operation .....	VII - 10
7-3-2	Setup Example .....	VII - 14
7-4	16-bit Event Count .....	VII - 16
7-4-1	Operation .....	VII - 16
7-4-2	Setup Example .....	VII - 18
7-5	16-bit Timer Pulse Output .....	VII - 20
7-5-1	Operation .....	VII - 20
7-5-2	Setup Example .....	VII - 22
7-6	16-bit Standard PWM Output (Only duty can be changed consecutively) .....	VII - 24
7-6-1	Operation .....	VII - 24
7-6-2	Setup Example .....	VII - 26
7-7	16-bit High Precision PWM Output (Cycle/Duty can be changed consecutively) .....	VII - 28
7-7-1	Operation .....	VII - 28
7-7-2	Setup Example .....	VII - 30
7-8	16-bit Timer Synchronous Output .....	VII - 32
7-8-1	Operation .....	VII - 32
7-8-2	Setup Example .....	VII - 33
7-9	16-bit Timer Capture .....	VII - 35
7-9-1	Operation .....	VII - 35
7-9-2	Setup Example .....	VII - 38

## Chapter 8 Time Base Timer / 8-bit Free-running Timer

8-1	Overview .....	VIII - 2
8-1-1	Functions .....	VIII - 2
8-1-2	Block Diagram .....	VIII - 3
8-2	Control Registers .....	VIII - 4
8-2-1	Control Registers .....	VIII - 4
8-2-2	Programmable Timer Registers .....	VIII - 5
8-2-3	Timer Mode Registers .....	VIII - 6
8-3	8-bit Free-running Timer .....	VIII - 7
8-3-1	Operation .....	VIII - 7
8-3-2	Setup Example .....	VIII - 10
8-4	Time Base Timer .....	VIII - 12
8-4-1	Operation .....	VIII - 12
8-4-2	Setup Example .....	VIII - 14

## Chapter 9 Watchdog Timer

9-1	Overview .....	IX - 2
9-1-1	Block Diagram .....	IX - 2

9-2	Control Registers .....	IX - 3
9-3	Operation .....	IX - 4
9-3-1	Operation .....	IX - 4
9-3-2	Setup Example .....	IX - 7

## Chapter 10 Buzzer

10-1	Overview .....	X - 2
10-1-1	Block Diagram .....	X - 2
10-2	Control Register .....	X - 3
10-3	Operation .....	X - 4
10-3-1	Operation .....	X - 4
10-3-2	Setup Example .....	X - 5

## Chapter 11 Serial Interface 0

11-1	Overview .....	XI - 2
11-1-1	Functions .....	XI - 2
11-1-2	Block Diagram .....	XI - 3
11-2	Control Registers .....	XI - 4
11-2-1	Registers .....	XI - 4
11-2-2	Data Buffer Registers .....	XI - 5
11-2-3	Mode Registers .....	XI - 6
11-3	Operation .....	XI - 12
11-3-1	Clock Synchronous Serial Interface .....	XI - 12
11-3-2	Setup Example .....	XI - 27
11-3-3	UART Serial Interface .....	XI - 30
11-3-4	Setup Example .....	XI - 45

## Chapter 12 Serial Interface 1

12-1	Overview .....	XII - 2
12-1-1	Functions .....	XII - 2
12-1-2	Block Diagram .....	XII - 3
12-2	Control Registers .....	XII - 4
12-2-1	Registers .....	XII - 4
12-2-2	Data Buffer Registers .....	XII - 5
12-2-3	Mode Registers .....	XII - 6
12-3	Operation .....	XII - 11
12-3-1	Clock Synchronous Serial Interface .....	XII - 11
12-3-2	Setup Example .....	XII - 26
12-3-3	UART Serial Interface .....	XII - 29

12-3-4	Setup Example .....	XII - 42
12-3-5	IC Card I/F .....	XII - 48
12-3-6	Setup Example .....	XII - 55

## Chapter 13 Serial Interface 2

13-1	Overview .....	XIII - 2
13-1-1	Functions .....	XIII - 2
13-1-2	Block Diagram .....	XIII - 3
13-2	Control Registers .....	XIII - 4
13-2-1	Registers List .....	XIII - 4
13-2-2	Data Register .....	XIII - 5
13-2-3	Mode Registers .....	XIII - 6
13-3	Operation .....	XIII - 9
13-3-1	Clock Synchronous Serial Interface .....	XIII - 9
13-3-2	Setup Example .....	XIII - 24

## Chapter 14 Serial Interface 3

14-1	Overview .....	XIV - 2
14-1-1	Functions .....	XIV - 2
14-1-2	Block Diagram .....	XIV - 3
14-2	Control Registers .....	XIV - 4
14-2-1	Registers .....	XIV - 4
14-2-2	Data Register .....	XIV - 5
14-2-3	Mode Registers .....	XIV - 6
14-3	Operation .....	XIV - 10
14-3-1	Clock Synchronous Serial Interface .....	XIV - 10
14-3-2	Setup Example .....	XIV - 24
14-3-3	Single Master IIC Interface .....	XIV - 27
14-3-4	Setup Example .....	XIV - 36

## Chapter 15 Automatic Transfer Controller

15-1	Overview .....	XV - 2
15-1-1	ATC1 .....	XV - 2
15-1-2	Functions .....	XV - 3
15-1-3	Block Diagram .....	XV - 4
15-2	Control Registers .....	XV - 5
15-2-1	Registers .....	XV - 5
15-3	Operation .....	XV - 9

15-3-1	Basic Operations and Timing .....	XV - 9
15-3-2	Setting the Memory Address .....	XV - 11
15-3-3	Setting the Data Transfer Count .....	XV - 12
15-3-4	Setting the Data Transfer Modes .....	XV - 13
15-3-5	Transfer Mode 0 .....	XV - 14
15-3-6	Transfer Mode 1 .....	XV - 15
15-3-7	Transfer Mode 2 .....	XV - 16
15-3-8	Transfer Mode 3 .....	XV - 17
15-3-9	Transfer Mode 4 .....	XV - 18
15-3-10	Transfer Mode 5 .....	XV - 19
15-3-11	Transfer Mode 6 .....	XV - 20
15-3-12	Transfer Mode 7 .....	XV - 22
15-3-13	Transfer Mode 8 .....	XV - 24
15-3-14	Transfer Mode 9 .....	XV - 26
15-3-15	Transfer Mode A .....	XV - 28
15-3-16	Transfer Mode B .....	XV - 29
15-3-17	Transfer Mode C .....	XV - 30
15-3-18	Transfer Mode D .....	XV - 31
15-3-19	Transfer Mode E .....	XV - 32
15-3-20	Transfer Mode F .....	XV - 33
15-4	Setup Example .....	XV - 34

## Chapter 16 A/D Converter

16-1	Overview .....	XVI - 2
16-1-1	Functions .....	XVI - 2
16-1-2	Block Diagram .....	XVI - 3
16-2	Control Registers .....	XVI - 4
16-2-1	Registers .....	XVI - 4
16-2-2	Control Registers .....	XVI - 5
16-2-3	Data Buffers .....	XVI - 7
16-3	Operation .....	XVI - 8
16-3-1	Setup .....	XVI - 10
16-3-2	Setup Example .....	XVI - 12
16-3-3	Cautions .....	XVI - 16

## Chapter 17 D/A Converter

17-1	Overview .....	XVII - 2
17-2	D/A Conversion .....	XVII - 3
17-3	D/A Converter Control Registers .....	XVII - 4
17-3-1	Overview .....	XVII - 4
17-3-2	D/A Converter Control Register (DACTR) .....	XVII - 5
17-3-3	D/A Conversion Input Data Registers .....	XVII - 6
17-4	D/A Converter Setup Example .....	XVII - 7



## Chapter 18 AC Timing Variable Functions

18-1	Overview .....	XVIII - 2
18-2	Operation .....	XVIII - 3
18-2-1	Setup .....	XVIII - 3
18-2-2	Operation .....	XVIII - 5
18-2-3	Setup Example .....	XVIII - 6

## Chapter 19 Appendices

19-1	EPROM Versions .....	XIX - 2
19-1-1	Overview .....	XIX - 2
19-1-2	Cautions on Use .....	XIX - 3
19-1-3	Erasing Data in Windowed Package .....	XIX - 4
19-1-4	Differences between Mask ROM version and EPROM version .....	XIX - 5
19-1-5	Writing to Microcomputer with Internal EPROM .....	XIX - 6
19-1-6	Cautions on Operation of ROM Writer .....	XIX - 8
19-1-7	Programming Adapter Connection .....	XIX - 9
19-2	Differences from the previous model .....	XIX - 10
19-3	Probe Switches (PRB-ADP101C12/49(100 PIN)) .....	XIX - 11
19-4	Special Function Registers List .....	XIX - 12
19-5	Instruction Set .....	XIX - 25
19-6	Instruction Map .....	XIX - 31

## Chapter 20 Appendices

20-1	Overview .....	XX - 2
20-1-1	Overview .....	XX - 2
20-1-2	Differences between Mask ROM version and Flash EEPROM version .....	XX - 4
20-2	Pin Descriptions .....	XX - 5
20-3	Electrical Characteristics .....	XX - 6
20-3-1	Absolute Maximum Ratings .....	XX - 6
20-3-2	Operating Conditions .....	XX - 7
20-3-3	DC Characteristics .....	XX - 10
20-3-4	A/D Converter Characteristics .....	XX - 15
20-3-5	D/A Converter Characteristics .....	XX - 16
20-4	Reprogramming Flow .....	XX - 17
20-5	PROM writer mode .....	XX - 18
20-6	Onboard Serial Programming Mode .....	XX - 20
20-6-1	Overview .....	XX - 20
20-6-2	Circuit Requirements for the Target Board .....	XX - 21
20-6-3	On-board Programming Mode .....	XX - 23
20-6-4	Memory Space .....	XX - 25





## 1-1 Overview

### 1-1-1 Overview

The MN101C series of 8-bit single-chip microcontroller incorporate multiple types of peripheral functions. This chip series is well suited for camera, VCR, MD, TV, CD, LD, printer, telephone, home automation, pager, air conditioner, PPC remote control, fax machine, musical instrument, and other applications.

The MN101C49K series brings to embedded microcontroller applications flexible, optimized hardware configurations and a simple efficient instruction set. The MN101C49K has an internal 224 KB of ROM and 10 KB of RAM. Peripheral functions include 6 external interrupts, 17 internal interrupts including NMI, 8 timer counters, 4 sets of serial interfaces, A/D converter, D/A converter, watchdog timer, automatic data transfer, synchronous output, buzzer output, and remote control output. The configuration of this microcontroller is well suited for application such as a system controller in a camera, VCR selection timer, CD player, or MD.

With two oscillation systems (max.20 MHz/32 kHz) contained on the chip, the system clock can be switched to high speed oscillation (**NORMAL mode**), or to low speed oscillation (**SLOW mode**). The system clock is generated by dividing the oscillation clock. The best operation clock for the system can be selected by switching its frequency by software. There are 2 choices for high speed oscillation : the normal mode, which has a system clock based on the clock ( $f_{osc}/2$ ) divided by 2, and the 2x-speed mode, which has a system clock based on the same cycle clock ( $f_{osc}$ ).

On the normal mode, when the oscillation source( $f_{osc}$ ) is 8 MHz, **minimum instructions execution time** is for 250 ns, and when  $f_{osc}$  is 20 MHz, it is 100 ns. On the 2x-speed mode, CPU is operated with the same cycle to the external clock, when  $f_{osc}$  is 8 MHz, minimum instructions execution time is 125 ns. The packages are 100-pin QFP and 100-pin LQFP.

### 1-1-2 Product Summary

This manual describes the following models of the MN101C49K series. These products have same peripheral functions. MN101C49K is main in this manual. Differences between MN101C49G/49H/49K and MN101CP49K are shown in table 19-1-1 "Differences between MASK ROM version and internal EPROM version".

And MN101CF49K is described on another manual.

**Table 1-1-1 Product Summary**

Model	ROM Size	RAM Size	Classification
MN101C49G	128 KB	4 KB	Mask ROM version
MN101C49H	160 KB	6 KB	Mask ROM version
MN101C49K	224 KB	10 KB	Mask ROM version
MN101CP49K	224 KB	10 KB	EPROM version
MN101CF49K	224 KB	10 KB	Flash EEPROM version

## 1-2 Hardware Functions

### CPU Core

#### MN101C Core

- LOAD-STORE architecture (3-stage pipeline)
- Half-byte instruction set / Handy addressing
- Memory addressing space is 256 KB
- Minimum instructions execution time

#### High speed oscillation

[normal]	0.10 $\mu$ s	/	20 MHz	(4.5 V to 5.5 V)
	0.238 $\mu$ s	/	8.39 MHz	(2.7 V to 5.5 V)
	1.00 $\mu$ s	/	2 MHz	(2.0 V to 5.5 V) *1
[2x-speed]	0.119 $\mu$ s	/	8.39 MHz	(4.5 V to 5.5 V)
	0.25 $\mu$ s	/	4 MHz	(3.0 V to 5.5 V)
Low speed oscillation	61.04 $\mu$ s	/	32.768 kHz	(2.0 V to 5.5 V) *1

\*1 : Minimum rating for EPROM vers. is 2.7 V to 5.5 V.

- Operation modes

NORMAL mode ( High speed oscillation )

SLOW mode ( Low speed oscillation )

HALT mode

STOP mode

(The operation clock can be switched in each mode.)

### Memory bank

- Data memory space expansion by bank form (4 banks unit : 64 KB / 1 bank)
- Bank for source address / Bank for destination address

### ROM correction

- Max.3 parts in program can be corrected

### Internal memory

**ROM 224 KB** \*2

**RAM 10 KB** \*2

\*2:Differs depending upon the model. [  Chapter 1. 1-1-1 Product Summary ]

### Interrupts

#### 17 Internal interrupts

<Non-maskable interrupt (NMI)>

- Incorrect code execution interrupt and Watchdog timer interrupt

< Timer interrupts >

- Timer 0 interrupt
- Timer 1 interrupt
- Timer 2 interrupt
- Timer 3 interrupt
- Timer 4 interrupt
- Timer 6 interrupt
- Time base interrupt
- Timer 7 interrupt
- Match interrupt for Timer 7 compare register 2

< Serial interface interrupts >

- Serial interface 0 interrupt
- Serial interface 0 UART reception interrupt
- Serial interface 1 interrupt
- Serial interface 2 interrupt
- Serial interface 3 interrupt

< A/D interrupt >

- A/D converter interrupt

< Automatic transfer controller(ATC) interrupt >

- ATC 1 interrupt

**6 External interrupts**

- IRQ0 : Edge selectable. With/Without noise filter.
- IRQ1 : Edge selectable. With/Without noise filter. AC zero cross detector.
- IRQ2 : Edge selectable. Both edges interrupt.  
(STOP/HALT : can be recovered at the both edges)
- IRQ3 : Edge selectable. Both edges interrupt.  
(STOP/HALT : can be recovered at the both edges)
- IRQ4 : Edge selectable. Key interrupt function.
- IRQ5 : Edge selectable.

**Timers**

**8 timers ( 7 can operate independently )**

- 8-bit timer for general use 3 sets
- 8-bit timer for general use (UART baud rate timer) 2 sets
- 8-bit free-running timer 1 set
- Time base timer 1 set
- 16-bit timer for general use 1 set

**Timer 0 ( 8-bit timer for general use )**

- Square wave output ( Timer pulse output ), PWM output, Event count, Remote control carrier output, Simple pulse width measurement, Real time output control
- Clock source  
fosc, fosc/4, fosc/16, fosc/32, fosc/64, fs/2, fs/4, fx, external clock

**Timer 1 ( 8-bit timer for general use )**

- Square wave output ( Timer pulse output ), Event count, 16-bit cascade connection function ( connected to timer 0 ), Timer synchronous output
- Clock source  
fosc, fosc/4, fosc/16, fosc/64, fosc/128, fs/2, fs/8, fx, external clock

**Timer 2 ( 8-bit timer for general use or UART baud rate timer )**

- Square wave output ( Timer pulse output ), PWM output, Event count, Timer synchronous output, Simple pulse width measurement, Real time output control, Serial interface transfer clock
- Clock source  
fosc, fosc/4, fosc/16, fosc/32, fosc/64, fs/2, fs/4, fx, external clock

**Timer 3 ( 8-bit timer for general use )**

- Square wave output ( Timer pulse output ), Event counter, Serial transfer clock, 16-bit cascade connection function ( connect to timer 2 ), Remote control carrier output
- Clock source  
fosc, fosc/4, fosc/16, fosc/64, fosc/128, fs/2, fs/8, fx, external clock

**Timer 4 ( 8-bit timer for general use or UART baud rate timer )**

- Square wave output ( Timer pulse output ), PWM output, Event count Simple pulse width measurement, Serial interface transfer clock
- Clock source  
fosc, fosc/4, fosc/16, fosc/32, fosc/64, fs/2, fs/4, fx, external clock

**Timer 6 ( 8-bit free-running timer, Time base timer )****□ 8-bit free-running timer**

- Clock source  
fosc, fosc/2<sup>12</sup>, fosc/2<sup>13</sup>, fs, fx, fx/2<sup>12</sup>, fx/2<sup>13</sup>

**□ Time base timer**

- Interrupt generation cycle  
fosc/2<sup>7</sup>, fosc/2<sup>8</sup>, fosc/2<sup>9</sup>, fosc/2<sup>10</sup>, fosc/2<sup>13</sup>, fosc/2<sup>15</sup>,  
fx/2<sup>7</sup>, fx/2<sup>8</sup>, fx/2<sup>9</sup>, fx/2<sup>10</sup>, fx/2<sup>13</sup>, fx/2<sup>15</sup>  
at 32.768 kHz for low speed oscillation input  
can be set to measure one minute intervals

**Timer 7 ( 16-bit timer for general use )**

- Clock source  
fosc, fosc/2, fosc/4, fosc/16, fs, fs/2, fs/4, fs/16,  
1/1, 1/2, 1/4, 1/16 of the external clock
- Hardware organization
 

Compare register with double buffer	2 sets
Input capture register	1 set
Timer interrupt	2 vectors
- Timer functions  
Square wave output ( Timer pulse output ), Event count,  
High precision PWM output ( Cycle / Duty continuous changeable),  
Timer synchronous output, Input capture function ( Both edges  
can be operated )
- Real time output control  
At the falling edge of the external interrupt 0 (IRQ0), PWM output  
( Timer output ) is controlled to 3 values ; "fixed high", "fixed low",  
"Hi-z".

**Watchdog timer**

- Watchdog timer frequency can be selected from fs/2<sup>16</sup>, fs/2<sup>18</sup> or fs/2<sup>20</sup>.

**Remote control output**

Based on the timer 0, and timer 3 output, a remote control carrier with duty cycle of 1/2 or 1/3 can be output.

## Synchronous output

### Timer synchronous output, Interrupt synchronous output

- Port D outputs the latched data, on the event timing of the synchronous output signal of timer 1, 2, or 7, or of the external interrupt 2 (IRQ 2).

## Buzzer output

Output frequency can be selected from  $f_{osc}/2^9$ ,  $f_{osc}/2^{10}$ ,  $f_{osc}/2^{11}$ ,  $f_{osc}/2^{12}$ ,  $f_{osc}/2^{13}$ ,  $f_{osc}/2^{14}$ ,  $f_x/2^3$ ,  $f_x/2^4$ .

## Automatic transfer controller (ATC)

Data in the whole memory space (256 KB) can be transferred.

- External interrupt start / internal event start / software start
- Max. 255 bytes continuous transfer
- Support serial interface sequence transmission / reception
- Burst transfer ( interrupt shutdown is built-in )

**A/D converter**                      **10 bits X 8 channels input**

**D/A converter**                      **8 bits X 4 channels input**

**Serial interface**                      **4 types**

### Serial interface 0 ( Duplex UART / Synchronous serial interface )

#### □ Synchronous serial interface

- Transfer clock source  
 $f_{osc}/2$ ,  $f_{osc}/4$ ,  $f_{osc}/16$ ,  $f_{osc}/64$ ,  $f_s/2$ ,  $f_s/4$   
UART baud rate timer ( timers 2 and 4 ) output
- MSB/LSB can be selected as the first bit to be transferred. Any transfer size from 1 to 8 bits can be selected.
- Sequence transmission, sequence reception or both are available.

#### □ Duplex UART ( Baud rate timer : Timers 2 and 4 )

- Parity check, Overrun error, Framing error detection
- Transfer size 7 to 8 bits can be selected.
- At UART communication, transmission / reception complete interrupts are available.

### Serial interface 1 ( Half-duplex UART / Synchronous serial interface )

#### □ Synchronous serial interface

- Transfer clock source  
 $f_{osc}/2$ ,  $f_{osc}/4$ ,  $f_{osc}/16$ ,  $f_{osc}/64$ ,  $f_s/2$ ,  $f_s/4$   
UART baud rate timer ( timer 4 ) output
- MSB/LSB can be selected as the first bit to be transferred. Any transfer size 1 to 8 bits can be selected.
- Sequence transmission, sequence reception or both are available.

#### □ Half-duplex UART ( Baud rate timer : Timer 4 )

- Parity check, Overrun error, Framing error detection
- Transfer size 7 to 8 bits can be selected.



**Serial interface 2 ( Synchronous serial interface )**

- Transfer clock source  
fosc/2, fosc/4, fosc/16, fosc/32, fs/2, fs/4, Timer 3 output
  - MSB/LSB can be selected as the first bit to be transferred. Any transfer size 1 to 8 bits can be selected.
  - Sequence transmission, sequence reception or both are available.
- [Note : When Matsushita standard serial writer is used for flash memory version, serial interface 2 is used for program transfer.]

**Serial interface 3 ( Single master IIC / Synchronous serial interface )****□ Synchronous serial interface**

- Transfer clock source  
fosc/2, fosc/4, fosc/16, fosc/32, fs/2, fs/4, timer 3 output
- MSB/LSB can be selected as the first bit to be transferred. Any transfer size 1 to 8 bits can be selected.
- Sequence transmission, sequence reception or both are available.

**□ Single master IIC**

- IIC communication for single master ( 9-bit transfer )

**LED driver****8 pins****Port****I/O ports****73 pins**

- LED ( large current ) driver pin 8 pins
- External memory I/F pin 29 pins
- External DMA I/F pin 5 pins
- dual function for D/A output 4 pins

**Input ports****15 pins**

- dual function for External interrupt 6 pins
- dual function for A/D input 8 pins

**Special pins**

- Analog reference voltage input pin 4 pins
- Operation mode input pin 1 pin
- Reset input pin 1 pin
- Power pin 2 pins
- Oscillation pin 4 pins

**Package****100-pin QFP ( 18 mm square / 0.65 mm pitch )**

code name : QFP100-P-1818B

**100-pin LQFP ( 14 mm square / 0.5 mm pitch )**

code name : LQFP100-P-1414

# 1-3 Pin Description

## 1-3-1 Pin Configuration

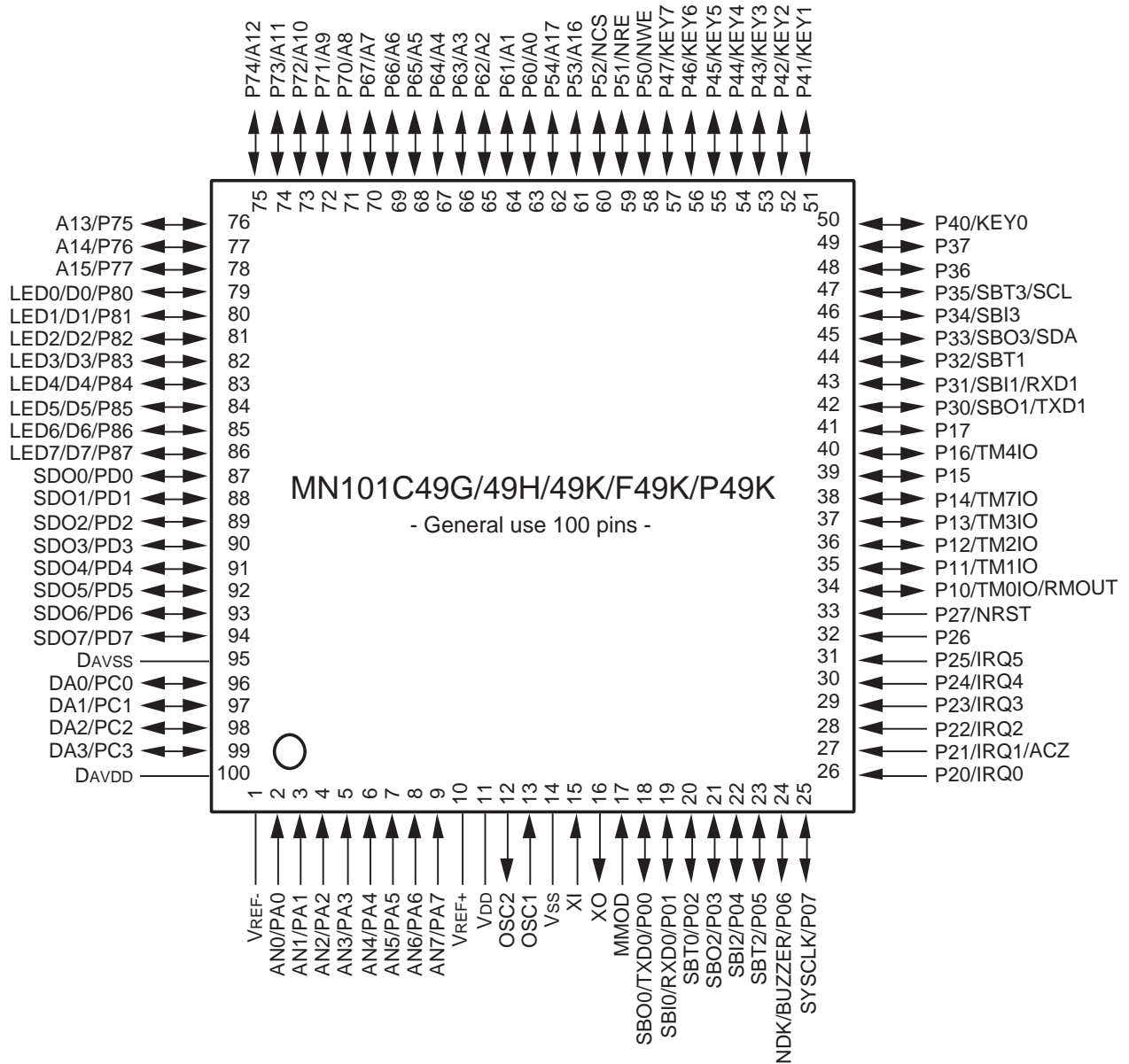


Figure 1-3-1 Pin Configuration ( 100QFP/100LQFP : Top view )

## 1-3-2 Pin Specification

**Table 1-3-1 Pin Specification ( 1/2 )**

Pins	Special Functions	I/O	Direction Control	Pin Control	Functions Description
P00	SBO0/TXD0	in/out	P0DIR0	P0PUL0	SBO0 : Serial interface 0 transmission data output TXD0 : UART0 transmission data output
P01	SBI0/RXD0	in/out	P0DIR1	P0PUL1	SBI0 : Serial interface 0 reception data input RXD0 : UART0 reception data input
P02	SBT0	in/out	P0DIR2	P0PUL2	SBT0 : Serial interface 0 clock I/O
P03	SBO2	in/out	P0DIR3	P0PUL3	SBO2 : Serial interface 2 transmission data output
P04	SBI2	in/out	P0DIR4	P0PUL4	SBI2 : Serial interface 2 reception data input
P05	SBT2	in/out	P0DIR5	P0PUL5	SBT2 : Serial interface 2 clock I/O
P06	NDK BUZZER	in/out	P0DIR6	P0PUL6	NDK : Data acknowledge signal BUZZER : Buzzer output
P07	SYSCCLK	in/out	P0DIR7	P0PUL7	SYSCCLK : System clock output
P10	TM0IO RMOU	in/out	P1DIR0	P1PUL0	TM0IO : Timer 0 I/O RMOU : Remote control carrier output
P11	TM1IO	in/out	P1DIR1	P1PUL1	TM1IO : Timer 1 I/O
P12	TM2IO	in/out	P1DIR2	P1PUL2	TM2IO : Timer 2 I/O
P13	TM3IO	in/out	P1DIR3	P1PUL3	TM3IO : Timer 3 I/O
P14	TM7IO	in/out	P1DIR4	P1PUL4	TM7IO : Timer 7 I/O
P15		in/out	P1DIR5	P1PUL5	
P16	TM4IO	in/out	P1DIR6	P1PUL6	TM4IO : Timer 4 I/O
P17		in/out	P1DIR7	P1PUL7	
P20	IRQ0	in	-	P2PUL0	IRQ0 : External interrupt 0
P21	IRQ1 ACZ	in	-	P2PUL1	IRQ1 : External interrupt 1 ACZ : Zero-cross input
P22	IRQ2	in	-	P2PUL2	IRQ2 : External interrupt 2
P23	IRQ3	in	-	P2PUL3	IRQ3 : External interrupt 3
P24	IRQ4	in	-	P2PUL4	IRQ4 : External interrupt 4
P25	IRQ5	in	-	P2PUL5	IRQ5 : External interrupt 5
P26		in	-	P2PUL6	
P27	NRST	in	-	-	NRST : Reset
P30	SBO1/TXD1	in/out	P3DIR0	P3PUL0	SBO1 : Serial interface1 transmission data output TXD1 : UART 1 Transmission data output
P31	SBI1/RXD1	in/out	P3DIR1	P3PUL1	SBI1 : Serial interface1 reception data input RXD1 : UART 1 Reception data input
P32	SBT1	in/out	P3DIR2	P3PUL2	SBT1 : Serial interface1 clock I/O
P33	SBO3	in/out	P3DIR3	P3PUL3	SBO3 : Serial interface 3 transmission data output
P34	SBI3	in/out	P3DIR4	P3PUL4	SBI3 : Serial interface 3 reception data input
P35	SBT3	in/out	P3DIR5	P3PUL5	SBT3 : Serial interface 3 clock I/O
P36		in/out	P3DIR6	P3PUL6	
P37		in/out	P3DIR7	P3PUL7	
P40	KEY0	in/out	P4DIR0	P4PUL0	KEY0 : Key interrupt input 0
P41	KEY1	in/out	P4DIR1	P4PUL1	KEY1 : Key interrupt input 1
P42	KEY2	in/out	P4DIR2	P4PUL2	KEY2 : Key interrupt input 2
P43	KEY3	in/out	P4DIR3	P4PUL3	KEY3 : Key interrupt input 3
P44	KEY4	in/out	P4DIR4	P4PUL4	KEY4 : Key interrupt input 4
P45	KEY5	in/out	P4DIR5	P4PUL5	KEY5 : Key interrupt input 5
P46	KEY6	in/out	P4DIR6	P4PUL6	KEY6 : Key interrupt input 6
P47	KEY7	in/out	P4DIR7	P4PUL7	KEY7 : Key interrupt input 7
P50	NWE	in/out	P5DIR0	P5PUL0	NWE : Write enable signal
P51	NRE	in/out	P5DIR1	P5PUL1	NRE : Read enable signal
P52	NCS	in/out	P5DIR2	P5PUL2	NCS : Chip select signal
P53	A16	in/out	P5DIR3	P5PUL3	A16 : Address output (bp16)
P54	A17	in/out	P5DIR4	P5PUL4	A17 : Address output (bp17)

**Table 1-3-2 Pin Specification (2/2)**

Pins	Special Functions	I/O	Direction Control	Pin Control	Functions Description
P60	A0	in/out	P6DIR0	P6PUL0	A0 : Address output (bp0)
P61	A1	in/out	P6DIR1	P6PUL1	A1 : Address output (bp1)
P62	A2	in/out	P6DIR2	P6PUL2	A2 : Address output (bp2)
P63	A3	in/out	P6DIR3	P6PUL3	A3 : Address output (bp3)
P64	A4	in/out	P6DIR4	P6PUL4	A4 : Address output (bp4)
P65	A5	in/out	P6DIR5	P6PUL5	A5 : Address output (bp5)
P66	A6	in/out	P6DIR6	P6PUL6	A6 : Address output (bp6)
P67	A7	in/out	P6DIR7	P6PUL7	A7 : Address output (bp7)
P70	A8	in/out	P7DIR0	P7PUL0	A8 : Address output (bp8)
P71	A9	in/out	P7DIR1	P7PUL1	A9 : Address output (bp9)
P72	A10	in/out	P7DIR2	P7PUL2	A10 : Address output (bp10)
P73	A11	in/out	P7DIR3	P7PUL3	A11 : Address output (bp11)
P74	A12	in/out	P7DIR4	P7PUL4	A12 : Address output (bp12)
P75	A13	in/out	P7DIR5	P7PUL5	A13 : Address output (bp13)
P76	A14	in/out	P7DIR6	P7PUL6	A14 : Address output (bp14)
P77	A15	in/out	P7DIR7	P7PUL7	A15 : Address output (bp15)
P80	D0 LED0	in/out	P8DIR0	P8PUL0	D0 : Data I/O (bp0) LED0 : LED driver pin 0
P81	D1 LED1	in/out	P8DIR1	P8PUL1	D1 : Data I/O (bp1) LED1 : LED driver pin 1
P82	D2 LED2	in/out	P8DIR2	P8PUL2	D2 : Data I/O (bp2) LED2 : LED driver pin 2
P83	D3 LED3	in/out	P8DIR3	P8PUL3	D3 : Data I/O (bp3) LED3 : LED driver pin 3
P84	D4 LED4	in/out	P8DIR4	P8PUL4	D4 : Data I/O (bp4) LED4 : LED driver pin 4
P85	D5 LED5	in/out	P8DIR5	P8PUL5	D5 : Data I/O (bp5) LED5 : LED driver pin 5
P86	D6 LED6	in/out	P8DIR6	P8PUL6	D6 : Data I/O (bp6) LED6 : LED driver pin 6
P87	D7 LED7	in/out	P8DIR7	P8PUL7	D7 : Data I/O (bp7) LED7 : LED driver pin 7
PA0	AN0	in	-	PAPUL0	AN0 : Analog 0 input
PA1	AN1	in	-	PAPUL1	AN1 : Analog 1 input
PA2	AN2	in	-	PAPUL2	AN2 : Analog 2 input
PA3	AN3	in	-	PAPUL3	AN3 : Analog 3 input
PA4	AN4	in	-	PAPUL4	AN4 : Analog 4 input
PA5	AN5	in	-	PAPUL5	AN5 : Analog 5 input
PA6	AN6	in	-	PAPUL6	AN6 : Analog 6 input
PA7	AN7	in	-	PAPUL7	AN7 : Analog 7 input
PC0	DA0	in/out	PCDIR0	PCPUL0	DA0 : DA 0 output
PC1	DA1	in/out	PCDIR1	PCPUL1	DA1 : DA 1 output
PC2	DA2	in/out	PCDIR2	PCPUL2	DA2 : DA 2 output
PC3	DA3	in/out	PCDIR3	PCPUL3	DA3 : DA 3 output
PD0	SDO0	in/out	PDDIR0	PDPUL0	SDO0 : Timer synchronous output 0
PD1	SDO1	in/out	PDDIR1	PDPUL1	SDO1 : Timer synchronous output 1
PD2	SDO2	in/out	PDDIR2	PDPUL2	SDO2 : Timer synchronous output 2
PD3	SDO3	in/out	PDDIR3	PDPUL3	SDO3 : Timer synchronous output 3
PD4	SDO4	in/out	PDDIR4	PDPUL4	SDO4 : Timer synchronous output 4
PD5	SDO5	in/out	PDDIR5	PDPUL5	SDO5 : Timer synchronous output 5
PD6	SDO6	in/out	PDDIR6	PDPUL6	SDO6 : Timer synchronous output 6
PD7	SDO7	in/out	PDDIR7	PDPUL7	SDO7 : Timer synchronous output 7

## 1-3-3 Pin Functions

**Table 1-3-3 Pin Function Summary (1/7)**

Name	No.	I/O	Function	Description	Other Function
Vss VDD	14 11		Power supply pin	Supply 2.0 V to 5.5 V to VDD and 0 V to Vss.	
OSC1 OSC2	13 12	Input Output	Clock input pin Clock output pin	Connect these oscillation pins to ceramic or crystal oscillators for high-frequency clock operation. If the clock is an external input, connect it to OSC1 and leave OSC2 open. The chip will not operate with an external clock when using either the STOP or SLOW modes.	
XI XO	15 16	Input Output	Clock input pin Clock output pin	Connect these oscillation pins to crystal oscillators for low-frequency clock operation. If the clock is an external input, connect it to XI and leave XO open. The chip will not operate with an external clock when using the STOP mode. If these pins are not used, connect XI to Vss and leave XO open.	
NRST	33	Input	Reset pin [Active low]	This pin resets the chip when power is turned on, is allocated as P27 and contains an internal pull-up resistor (Typ.35 kΩ). Setting this pin low initializes the internal state of the device. Thereafter, setting the input to high releases the reset. The hardware waits for the system clock to stabilize, then processes the reset interrupt. Also, if "0" is written to P27 and the reset is initiated by software, a low level will be output. The output has an n-channel open-drain configuration. If a capacitor is to be inserted between NRST and Vss, it is recommended that a discharge diode be placed between NRST and VDD.	P27
P00 P01 P02 P03 P04 P05 P06 P07	18 19 20 21 22 23 24 25	I/O	I/O port 0	8-bit CMOS tri-state I/O port. Each bit can be set individually as either an input or output by the PODIR register. A pull-up resistor for each bit can be selected individually by the P0PLU register. At reset, the input mode is selected and pull-up resistors are disabled (high impedance output).	SBO0, TXD0 SB10, RXD0 SBT0 SBO2 SB12 SBT2 NDK, BUZZER SYSCLK
P10 P11 P12 P13 P14 P15 P16 P17	34 35 36 37 38 39 40 41	I/O	I/O port 1	8-bit CMOS tri-state I/O port. Each bit can be set individually as either an input or output by the P1DIR register. A pull-up resistor for each bit can be selected individually by the P1PLU register. At reset, the input mode is selected and pull-up resistors are disabled (high impedance output).	TM0IO, RMOUT TM1IO TM2IO TM3IO TM7IO  TM4IO

Table 1-3-4 Pin Function Summary (2/7)

Name	No.	I/O	Function	Description	Other Function
P20 P21 P22 P23 P24 P25 P26	26 27 28 29 30 31 32	Input	Input port 2	7-bit input port. A pull-up resistor for each bit can be selected individually by the P2PLU register. At reset, pull-up resistors are disabled.	IRQ0 IRQ1, ACZ IRQ2 IRQ3 IRQ4 IRQ5
P27	33	Input	I/O port 2	P27 has an n-channel open-drain configuration. When "0" is written and the reset is initiated by software, a low level will be output.	NRST
P30 P31 P32 P33 P34 P35 P36 P37	42 43 44 45 46 47 48 49	I/O	I/O port 3	8-bit CMOS tri-state I/O port. Each bit can be set individually as either an input or output by the P3DIR register. A pull-up resistor for each bit can be selected individually by the P3PLU register. At reset, the input mode is selected and pull-up resistors are disabled (high impedance output).	SBO1, TXD1 SBI1, RXD1 SBT1 SBO3 SBI3 SBT3
P40 P41 P42 P43 P44 P45 P46 P47	50 51 52 53 54 55 56 57	I/O	I/O port 4	8-bit CMOS tri-state I/O port. Each bit can be set individually as either an input or output by the P4DIR register. A pull-up resistor for each bit can be selected individually by the P4PLU register. At reset, the input mode is selected and pull-up resistors are disabled (high impedance output).	KEY0 KEY1 KEY2 KEY3 KEY4 KEY5 KEY6 KEY7
P50 P51 P52 P53 P54	58 59 60 61 62	I/O	I/O port 5	5-bit CMOS tri-state I/O port. Each bit can be set individually as either an input or output by the P5DIR register. A pull-up resistor for each bit can be selected individually by the P5PLU register. At reset, when single chip mode is selected, the input mode is selected and pull-up resistors for P50 to P54 are disabled (high impedance output). During processor mode, NWE, NRE, NCS, A16, and A17 are set to output mode.	NWE NRE NCS A16 A17
P60 P61 P62 P63 P64 P65 P66 P67	63 64 65 66 67 68 69 70	I/O	I/O port 6	8-bit CMOS tri-state I/O port. Each bit can be set individually as either an input or output by the P6DIR register. A pull-up resistor for each bit can be selected individually by the P6PLU register. At reset, when single chip mode is selected, the input mode is selected and pull-up resistors for P60 to P67 are disabled (high impedance output). During processor mode, output mode is selected for A0 to A7.	A0 A1 A2 A3 A4 A5 A6 A7

Table 1-3-5 Pin Function Summary (3/7)

Name	No.	I/O	Function	Description	Other Function
P70 P71 P72 P73 P74 P75 P76 P77	71 72 73 74 75 76 77 78	I/O	I/O port 7	8-bit CMOS tri-state I/O port. Each bit can be set individually as either an input or output by the P7DIR register. A pull-up or pull-down resistor for each bit can be selected individually by the P7PLUD register. However, pull-up and pull-down resistors cannot be mixed. At reset, when single-chip mode is selected, the input mode is selected and pull-up resistors for P70 to P77 are disabled (high impedance output). During processor mode, A8 to A15 are set to output mode.	A8 A9 A10 A11 A12 A13 A14 A15
P80 P81 P82 P83 P84 P85 P86 P87	79 80 81 82 83 84 85 86	I/O	I/O port 8	8-bit CMOS tri-state I/O port. Each individual bit can be switched to an input or output by the P8DIR register. A pull-up resistor for each bit can be selected individually by the P8PLU register. When configured as outputs, these pins can drive LEDs directly. At reset, when single-chip mode is selected, the input mode is selected and pull-up resistors for P80 to P87 are disabled (high impedance output). During processor mode, D0 to D7 are set to input mode (high impedance output).	D0, LED0 D1, LED1 D2, LED2 D3, LED3 D4, LED4 D5, LED5 D6, LED6 D7, LED7
PA0 PA1 PA2 PA3 PA4 PA5 PA6 PA7	2 3 4 5 6 7 8 9	Input	Input port A	8-bit input port. A pull-up or pull-down resistor for each bit can be selected individually by the PAPLUD register. However, pull-up and pull-down resistors cannot be mixed. At reset, the PA0 to PA7 input mode is selected and pull-up resistors are disabled.	AN0 AN1 AN2 AN3 AN4 AN5 AN6 AN7
PC0 PC1 PC2 PC3	96 97 98 99	I/O	I/O port C	4-bit CMOS tri-state I/O port. Each bit can be set individually as either an input or output by the PCDIR register. A pull-up resistor for each bit can be selected individually by the PCPLU register. At reset, the input mode is selected and pull-up resistors are disabled (high impedance output).	DA0 DA1 DA2 DA3
PD0 PD1 PD2 PD3 PD4 PD5 PD6 PD7	87 88 89 90 91 92 93 94	I/O	I/O port D	8-bit CMOS tri-state I/O port. Each bit can be set individually as either an input or output by the PDDIR register. A pull-up resistor for each bit can be selected individually by the PDPLU register. At reset, the input mode is selected and pull-up resistors are disabled (high impedance output).	SDO0 SDO1 SDO2 SDO3 SDO4 SDO5 SDO6 SDO7

**Table 1-3-6 Pin Function Summary (4/7)**

Name	No.	I/O	Function	Description	Other Function
SBO0 SBO1 SBO2 SBO3	18 42 21 45	Output	Serial interface transmission data output pins	Transmission data output pins for serial interfaces 0 to 3. The output configuration, either CMOS push-pull or n-channel open-drain can be selected. Pull-up resistors can be selected by the P0PLU register, the P3PLU register. Select output mode by the P0DIR register, the P3DIR register, and serial data output mode by serial mode register 1 (SC0MD1, SC1MD1, SC2MD1, SC3MD1). These can be used as normal I/O pins when the serial interface is not used.	P00, TXD0 P30, TXD1 P03 P33
SBi0 SBi1 SBi2 SBi3	19 43 22 46	Input	Serial interface reception data input pins	Reception data input pins for serial interfaces 0 to 3. Pull-up resistors can be selected by the P0PLU register, the P3PLU register. Select input mode by the P0DIR register, the P3DIR register, and serial input mode by the serial mode register 1 ( SC0MD1, SC1MD1, SC2MD1, SC3MD1). These can be used as normal I/O pins when the serial interface is not used.	P01, RXD0 P31, RXD1 P04 P34
SBT0 SBT1 SBT2 SBT3	20 44 23 47	I/O	Serial interface clock I/O pins	Clock I/O pins for serial interfaces 0 to 3. The output configuration, either CMOS push-pull or n-channel open-drain can be selected. Pull-up resistors can be selected by the P0PLU register and the P3PLU register. Select clock I/O for each communication mode by the P0DIR register, the P3DIR register and serial mode register 1 ( SC0MD1, SC1MD1, SC2MD1, SC3MD1). These can be used as normal I/O pins when the serial interface is not used.	P02 P32 P05 P35
TXD0 TXD1	18 42	Output	UART transmission data output pins	In the serial interface in UART mode, these pins are configured as the transmission data output pins. The output configuration, either CMOS push-pull or n-channel open-drain can be selected. Pull-up resistors can be selected by the P0PLU register and the P3PLU register. Select output mode by the P0DIR register and the P3DIR register, and serial data output by serial interface 1 mode register 1 ( SC0MD1, SC1MD1). These can be used as normal I/O pins when the serial interface is not used.	SBO0, P00 SBO1, P30



Table 1-3-7 Pin Function Summary (5/7)

Name	No.	I/O	Function	Description	Ohter Function
RXD0 RXD1	19 43	Input	UART reception data input pin	In the serial interface in UART mode, these pins are configured as the received data input pin. Pull-up resistors can be selected by the P3PLU register. Set this pin to the input mode by the P3DIR register, and to the serial input mode by the serial interface1 mode register 1 ( SC0MD1, SC1MD1). This can be used as normal I/O pin when the serial interface is not used.	SBI0, P01 SBI1, P31
TM0IO TM1IO TM2IO TM3IO TM4IO	34 35 36 37 40	I/O	Timer I/O pins	Event counter clock input pins, timer output and PWM signal output pins for 8-bit timers 0 to 4. To use these pins as event clock inputs, configure them as inputs by the P1DIR register. When the pins are used as inputs, pull-up resistors can be specified by the P1PLU register. For timer output, PWM signal output, select the special function pin by the port 1 output mode register (P1OMD) and set to the output mode by the P1DIR register. When not used for timer I/O, these can be used as normal I/O pins.	P10, RMOUT P11 P12 P13 P16
RMOUT	34	I/O	Remote control transmission signal output pin	Output pin for remote control transmission signal with a carrier signal. For remote control carrier output, select the special function pin by the port 1 output mode register (P1OMD) and set to the output mode by the P1DIR register. Also, set to the remote control carrier output by the remote control carrier output control register (RMCTR). This can be used as a normal I/O pin when remote control is not used.	P10, TM0IO
BUZZER	24	Output	Buzzer output	Piezoelectric buzzer driver pin. The driving frequency can be selected by the DLYCTR register. Select output mode by the P0DIR register and select P06 buzzer output by the DLYCTR register. When not used for buzzer output, this pin can be used as a normal I/O pin.	P06, NDK
TM7IO	38	I/O	Timer I/O pin	Event counter clock input pin, timer output and PWM signal output pin for 16-bit timer 7. To use this pin as event clock input, configure this as input by the P1DIR register. In the input mode, pull-up resistors can be selected by the P1PLU register. For timer output, PWM signal output, select the special function pin by the port 1 output mode register (P1OMD), and set to the output mode by the P1DIR register. When not used for timer I/O, this can be used as normal I/O pin.	P14

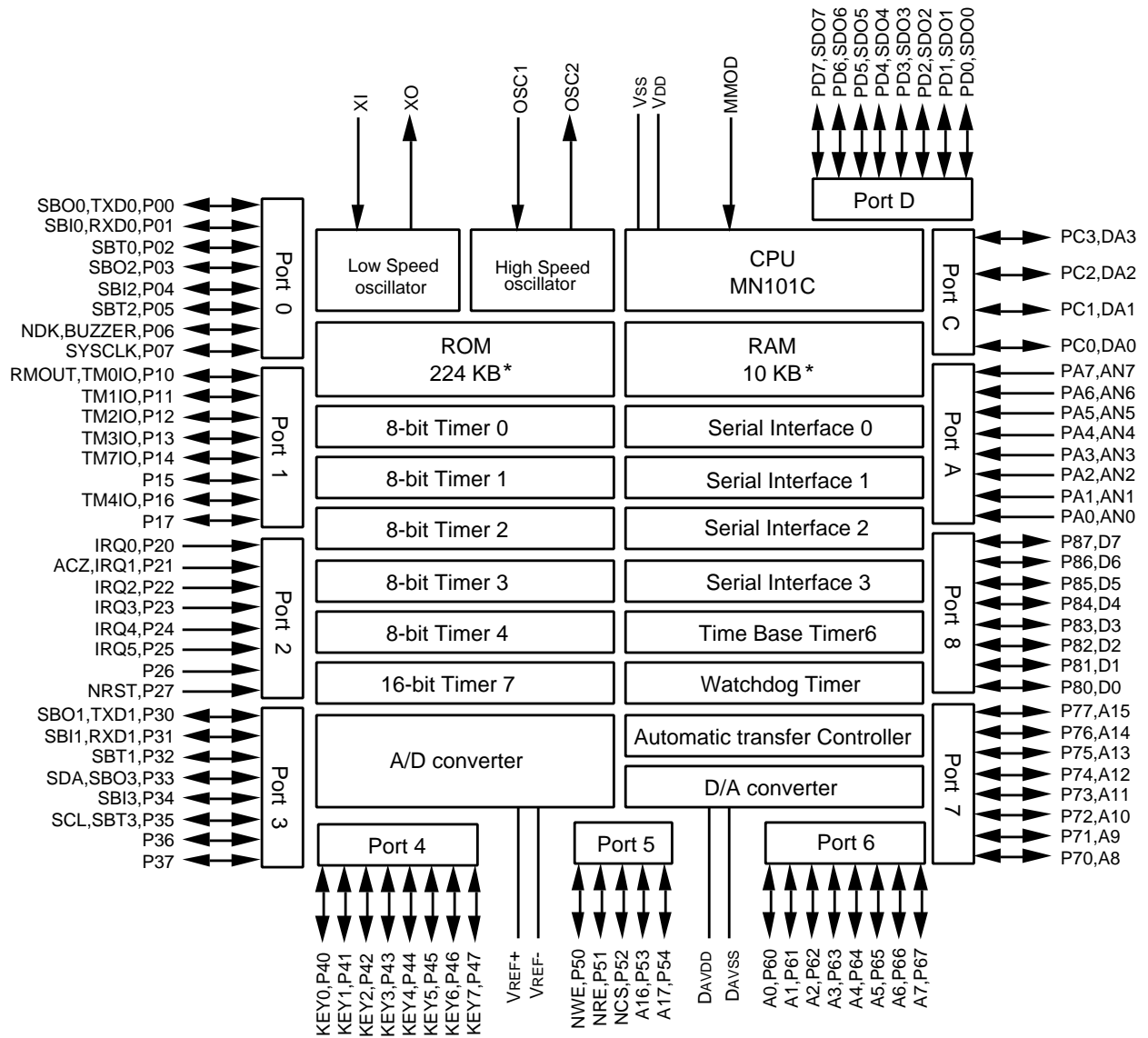
Table 1-3-8 Pin Function Summary (6/7)

Name	No.	I/O	Function	Description	Other Function
SDO0 SDO1 SDO2 SDO3 SDO4 SDO5 SDO6 SDO7	87 89 90 91 92 93 94 95	Output	Synchronous output pins	8-bit synchronous output pins. Synchronous output for each bit can be selected individually by the port D synchronous output control register (PDSY0). Set to the output mode by the P1DIR register. When not used for synchronous output, these pins can be used as a normal I/O pins.	PD0 PD1 PD2 PD3 PD4 PD5 PD6 PD7
VREF+ VREF-	10 1	- -	+power supply for A/D converter - power supply for A/D converter	Reference power supply pins for the A/D converter. Normally, the values of VREF+=VDD and VREF-=VSS are used.	
AN0 AN1 AN2 AN3 AN4 AN5 AN6 AN7	2 3 4 5 6 7 8 9	Input	Analog input pins	Analog input pins for an 8-channel, 10-bit A/D converter. When not used for analog input, these pins can be used as normal input pins.	PA0 PA1 PA2 PA3 PA4 PA5 PA6 PA7
DAVDD DAVSS	100 95	- -	+power supply for D/A converter - power supply for D/A converter	Reference power supply pins for the D/A converter. Normally, the values of DAVDD=VDD and DAVSS=VSS are used.	
DA0 DA1 DA2 DA3	96 97 98 99	Input	Analog output pins	Analog output pins for an 4-channel, 8-bit D/A converter. When not used for analog output, these pins can be used as normal I/O pins.	PC0 PC1 PC2 PC3
IRQ0 IRQ1 IRQ2 IRQ3 IRQ4 IRQ5	26 27 28 29 30 31	Input	External interrupt input pins	External interrupt input pins. The valid edge for IRQ0 to 5 can be selected with the IRQnICR register. IRQ1 is an external interrupt pin that is able to determine AC zero crossings. Both edge for IRQ2, 3 are valid for interrupt. When these are not used for interrupts, these can be used as normal input pins.	P20 P21, ACZ P22 P23 P24 P25
ACZ	27	Input	AC zero-cross detection input pin	An input pin for an AC zero-cross detection circuit. The AC zero-cross detection circuit outputs a high level when the input is at an intermediate level. It outputs a low level at all other times. ACZ input signal is connected to the P21 input circuit and the IQR1 interrupt circuit. When the AC zero-cross detection circuit is not used, this pin can be used as a normal P21 input.	P21, IRQ1



# 1-4 Block Diagram

## 1-4-1 Block Diagram



\*Differs depending upon the model. [ Table 1-1-1. Product Summary ]

Figure 1-4-1 Block Diagram

## 1-5 Electrical Characteristics

This LSI user's manual describes the standard specification. System clock (fs) is 1/2 of high speed oscillation at NORMAL mode, or 1/4 of low speed oscillation at SLOW mode. Please ask our sales offices for its own product specifications.

Model	MN101C49K
Contents	
Structure	CMOS integrated circuit
Application	General purpose
Function	8-bit single-chip microcontroller

### 1-5-1 Absolute Maximum Ratings<sup>\*2,\*3</sup> (voltages referenced to Vss)

No.	Parameter	Symbol	Rating	Unit	
1	Power supply voltage	V <sub>DD</sub>	- 0.3 to +7.0	V	
2	Input clamp current (ACZ)	I <sub>c</sub>	- 400 to 400	μA	
3	Input pin voltage	V <sub>I</sub>	- 0.3 to V <sub>DD</sub> +0.3	V	
4	Output pin voltage	V <sub>O</sub>	- 0.3 to V <sub>DD</sub> +0.3		
5	I/O pin voltage	V <sub>IO1</sub>	- 0.3 to V <sub>DD</sub> +0.3 (except ACZ)		
6	Peak output current	Port 8	I <sub>OL1</sub> (peak)	30	mA
7		Other than Port 8	I <sub>OL2</sub> (peak)	20	
8		All pins	I <sub>OH</sub> (peak)	- 10	
9	Average output current <sup>*1</sup>	Port 8	I <sub>OL1</sub> (avg)	20	
10		Other than Port 8	I <sub>OL2</sub> (avg)	15	
11		All pins	I <sub>OH</sub> (avg)	- 5	
12	Power dissipation	P <sub>D</sub>	400 (T <sub>a</sub> = +85 °C)	mW	
13	Operating ambient temperature	T <sub>a</sub>	- 40 to +85	°C	
14	Storage temperature	T <sub>stg</sub>	- 55 to +125		

\*1 Applied to any 100 ms period.

\*2 Connect at least one bypass capacitor of 0.1 μF or larger between the power supply pin and the ground for latch-up prevention.

\*3 The absolute maximum ratings are the limit values beyond which the LSI may be damaged and proper operation is not assured.

## 1-5-2 Operating Conditions [ NORMAL mode : $f_s=f_{osc}/2$ , SLOW mode : $f_s=f_x/4$ ]

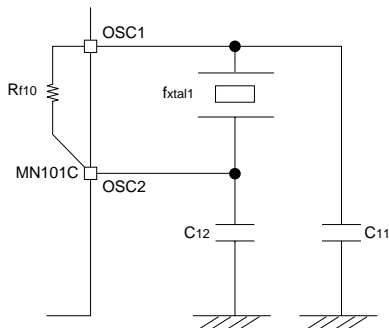
$T_a=-40\text{ }^\circ\text{C}$  to  $+85\text{ }^\circ\text{C}$  ( $-20\text{ }^\circ\text{C}$  to  $+70\text{ }^\circ\text{C}$ )  $V_{DD}=2.0\text{ V}$  (2.7 V) to 5.5 V  $V_{SS}=0\text{ V}$   
 EPROM vers. is in ( ).

Parameter	Symbol	Conditions	Rating			Unit	
			MIN	TYP	MAX		
Power supply voltage							
1	Power supply voltage	$V_{DD1}$	$f_{osc}\leq 20.0\text{ MHz}$ [normal mode : $f_s=f_{osc}/2$ ]	4.5	-	5.5	V
2		$V_{DD2}$	$f_{osc}\leq 8.39\text{ MHz}$ [normal mode : $f_s=f_{osc}/2$ ]	2.7	-	5.5	
3		$V_{DD3}$	$f_{osc}\leq 2.00\text{ MHz}$ [normal mode : $f_s=f_{osc}/2$ ]	2.0 (2.7)	-	5.5	
4		$V_{DD4}$	$f_{osc}\leq 8.39\text{ MHz}$ [2x speed mode : $f_s=f_{osc}$ ]	4.5	-	5.5	
5		$V_{DD5}$	$f_{osc}\leq 4.00\text{ MHz}$ [2x speed mode : $f_s=f_{osc}$ ]	3.0	-	5.5	
6		$V_{DD6}$	$f_x=32.768\text{ kHz}$	2.0 (2.7)	-	5.5	
7	Voltage to maintain RAM data	$V_{DD7}$	During STOP mode	1.8	-	5.5	
Operation speed *1							
8	minimum instruction execution time	tc1	$V_{DD}=4.5\text{ V}$ to 5.5 V [normal mode : $f_s=f_{osc}/2$ ]	0.100	-	-	$\mu\text{s}$
9		tc2	$V_{DD}=2.7\text{ V}$ to 5.5V [normal mode : $f_s=f_{osc}/2$ ]	0.238	-	-	
10		tc3	$V_{DD}=2.0\text{ V}$ (2.7 V) to 5.5 V [normal mode : $f_s=f_{osc}/2$ ]	1.00	-	-	
11		tc4	$V_{DD}=4.5\text{ V}$ to 5.5 V [2x speed mode : $f_s=f_{osc}$ ]	0.119	-	-	
12		tc5	$V_{DD}=3.0\text{ V}$ to 5.5 V [2x speed mode : $f_s=f_{osc}$ ]	0.250	-	-	
13		tc6	$V_{DD}=2.0\text{ V}$ (2.7 V) to 5.5 V [ $f_s=f_x/2$ ]	-	61.04	-	

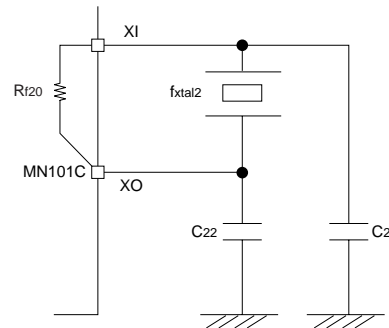
\*1 tc1, tc2, tc3, tc4, tc5 : 1/2 of high speed oscillation at NORMAL mode  
 tc6 : 1/4 of low speed oscillation at SLOW mode

Ta=-40 °C to +85 °C (-20 °C to +70 °C) V<sub>DD</sub>=2.0 V (2.7 V) to 5.5 V V<sub>SS</sub>=0 V  
 EPROM vers. is in ( ).

Parameter	Symbol	Conditions	Rating			Unit	
			MIN	TYP	MAX		
Crystal oscillator 1 Fig. 1-5-1							
14	Crystal frequency	f <sub>xtal1</sub>	V <sub>DD</sub> =4.5 V to 5.5 V	1.0	-	20.0	MHz
15	External capacitors	C <sub>11</sub>		-	20	-	pF
16		C <sub>12</sub>		-	20	-	
17	Internal feedback resistor	R <sub>f10</sub>		-	700	-	kΩ
Crystal oscillator 2 Fig. 1-5-2							
18	Crystal frequency	f <sub>xtal2</sub>		32.768	-	100	kHz
19	External capacitors	C <sub>21</sub>		-	20	-	pF
20		C <sub>22</sub>		-	20	-	
21	Internal feedback resistor	R <sub>f20</sub>		-	4.0	-	MΩ




The feedback resistor is built-in.



The feedback resistor is built-in.

Figure 1-5-1 Crystal Oscillator 1

Figure 1-5-2 Crystal Oscillator 2

 Connect the external capacitor suits the used pin. When crystal oscillator or ceramic oscillator is used, frequency is changed depending on the condenser rate. Therefore, please consult the manufacturer the external capacitors suits the used pin.

Ta=-40 °C to +85 °C (-20 °C to +70 °C ) V<sub>DD</sub>=2.0 V (2.7 V) to 5.5 V V<sub>SS</sub>=0 V  
 EPROM vers. is in ( ).

Parameter	Symbol	Conditions	Rating			Unit
			MIN	TYP	MAX	
External clock input 1 OSC1 (OSC2 is unconnected)						
22	Clock frequency	fosc	1.0	-	20.0	MHz
23	High level pulse width	t <sub>wh1</sub>	*2	Fig. 1-5-3	20.0	ns
24	Low level pulse width	t <sub>wl1</sub>			20.0	
25	Rising time	t <sub>wr1</sub>	Fig. 1-5-3	-	5.0	ns
26	Falling time	t <sub>wf1</sub>		-	5.0	
External clock input 2 XI (XO is unconnected)						
27	Clock frequency	f <sub>x</sub>	32.768	-	100	kHz
28	High level pulse width	t <sub>wh2</sub>	*2	Fig. 1-5-4	3.5	μs
29	Low level pulse width	t <sub>wl2</sub>			3.5	
30	Rising time	t <sub>wr2</sub>	Fig. 1-5-4	-	20	ns
31	Falling time	t <sub>wf2</sub>		-	20	

\*2 The clock duty rate in the standard mode should be 45% to 55%.

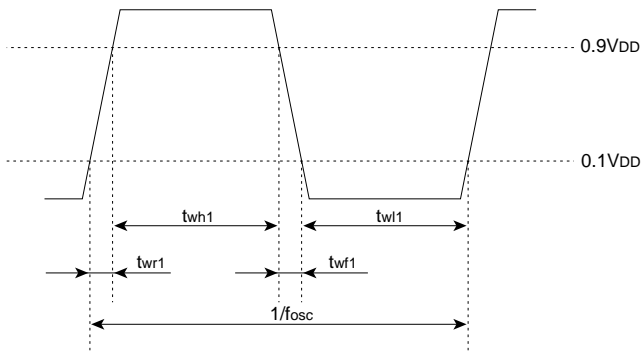


Figure 1-5-3 OSC1 Timing Chart

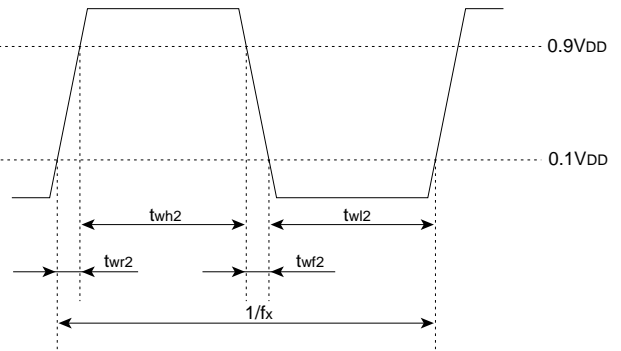


Figure 1-5-4 XI Timing Chart



## 1-5-3 DC Characteristics

$T_a = -40\text{ }^\circ\text{C}$  to  $+85\text{ }^\circ\text{C}$  ( $-20\text{ }^\circ\text{C}$  to  $70\text{ }^\circ\text{C}$ )  $V_{DD} = 2.0\text{ V}$  (2.7 V) to 5.5 V  $V_{SS} = 0\text{ V}$   
 EPROM vers. is in ( ).

Parameter	Symbol	Conditions	Rating			Unit	
			MIN	TYP	MAX		
Power supply current (no load at output pin) *1							
1	Power supply current	$I_{DD1}$	$f_{osc} = 20.0\text{ MHz}$ $V_{DD} = 5\text{ V}$ [the normal mode : $f_s = f_{osc}/2$ ]	-	30	70	mA
2		$I_{DD2}$	$f_{osc} = 8.39\text{ MHz}$ $V_{DD} = 5\text{ V}$ [the normal mode : $f_s = f_{osc}/2$ ]	-	15	30	
3		$I_{DD3}$	$f_x = 32.768\text{ kHz}$ $V_{DD} = 3\text{ V}$ ( $f_s = f_x/4$ )	-	40	120	$\mu\text{A}$
4	Supply current during HALT mode	$I_{DD4}$	$f_x = 32.768\text{ kHz}$ $V_{DD} = 3\text{ V}$ $T_a = 25\text{ }^\circ\text{C}$	-	5	11	
5		$I_{DD5}$	$f_x = 32.768\text{ kHz}$ $V_{DD} = 3\text{ V}$ ( $T_a = +70\text{ }^\circ\text{C}$ )	-	-	30	
6	Supply current during STOP mode	$I_{DD6}$	$V_{DD} = 5\text{ V}$ $T_a = 25\text{ }^\circ\text{C}$	-	0	30	
7		$I_{DD7}$	$V_{DD} = 5\text{ V}$ ( $T_a = +70\text{ }^\circ\text{C}$ )	-	-	60	

\*1 Measured under conditions of no load.

- The supply current during operation,  $I_{DD1}$ ( $I_{DD2}$ ), is measured under the following conditions : After all I/O pins are set to input mode and the oscillation is set to <NORMAL mode>, the MMOD pin is connected to  $V_{SS}$  level, the input pins are connected to  $V_{DD}$  level, and a 20 MHz(8.39 MHz) square wave of  $V_{DD}$  amplitude is input to the OSC1 pin.
- The supply current during operation,  $I_{DD3}$ , is measured under the following conditions : After all I/O pins are set to input mode and the oscillation is set to <SLOW mode>, the MMOD pin is connected to  $V_{SS}$  level, the input pins are connected to  $V_{DD}$  level, and a 32.768 kHz square wave of  $V_{DD}$  amplitude is input to the XI pin.
- The supply current during HALT mode,  $I_{DD4}$ ( $I_{DD5}$ ), is measured under the following conditions : After all I/O pins are set to input mode and the oscillation is set to <HALT mode>, the MMOD pin is connected to  $V_{SS}$  level, the input pins are connected to  $V_{DD}$  and an 32.768 kHz square wave of  $V_{DD}$  amplitude is input to the XI pin.
- The supply current during STOP mode,  $I_{DD6}$ ( $I_{DD7}$ ), is measured under the following conditions : After the oscillation is set to <STOP mode>, the MMOD pin is connected to  $V_{SS}$  level, the input pins are connected to  $V_{DD}$ , and the OSC1 and XI pins are unconnected.

$T_a = -40\text{ }^\circ\text{C}$  to  $+85\text{ }^\circ\text{C}$  ( $-20\text{ }^\circ\text{C}$  to  $+70\text{ }^\circ\text{C}$ )  $V_{DD} = 2.0\text{ V}$  (2.7 V) to 5.5 V  $V_{SS} = 0\text{ V}$   
 EPROM vers. is in ( ).

Parameter	Symbol	Conditions	Rating			Unit	
			MIN	TYP	MAX		
Input pin 1 MMOD							
8	Input high voltage 1	$V_{IH1}$		0.8 $V_{DD}$	-	$V_{DD}$	V
9	Input high voltage 2	$V_{IH2}$	$V_{DD} = 4.5\text{ V}$ to $5.5\text{ V}$	0.7 $V_{DD}$	-	$V_{DD}$	
10	Input low voltage 1	$V_{IL1}$		0	-	0.2 $V_{DD}$	
11	Input low voltage 2	$V_{IL2}$	$V_{DD} = 4.5\text{ V}$ to $5.5\text{ V}$	0	-	0.3 $V_{DD}$	
12	Input leakage current	$I_{LK1}$	$V_I = 0\text{ V}$ to $V_{DD}$	-	-	$\pm 10$	$\mu\text{A}$
Input pin 2 P20, P22 to P26 (Schmitt trigger input)							
13	Input high voltage	$V_{IH3}$		0.8 $V_{DD}$	-	$V_{DD}$	V
14	Input low voltage	$V_{IL3}$		0	-	0.2 $V_{DD}$	
15	Input leakage current	$I_{LK3}$	$V_I = 0\text{ V}$ to $V_{DD}$	-	-	$\pm 10$	$\mu\text{A}$
16	Input high current	$I_{IH3}$	$V_{DD} = 5.0\text{ V}$ $V_I = 1.5\text{ V}$ Pull-up resistor ON	-30	-100	-300	
Input pin 3-1 P21 (Schmitt trigger input)							
17	Input high voltage	$V_{IH4}$		0.8 $V_{DD}$	-	$V_{DD}$	V
18	Input low voltage	$V_{IL4}$		0	-	0.2 $V_{DD}$	
19	Input leakage current	$I_{LK4}$	$V_I = 0\text{ V}$ to $V_{DD}$	-	-	$\pm 10$	$\mu\text{A}$
20	Input high current	$I_{LK4}$	$V_{DD} = 5.0\text{ V}$ $V_I = 1.5\text{ V}$ Pull-up resistor ON	-30	-100	-300	
Input pin 3-2 P21 (at used as ACZ) $V_{DD} = 5\text{ V}$							
21	High detection voltage	$V_{DLH}$	Fig. 1-5-5	-	-	3.5	V
22		$V_{DHL}$		1.5	-	-	
23	Low detection voltage	$V_{DHH}$		4.5	-	-	
24		$V_{DLL}$		-	-	0.5	
25	Input leakage current	$I_{LK10}$	$V_I = 0\text{ V}$ to $V_{DD}$	-	-	$\pm 10$	$\mu\text{A}$
26	Input clamp current	$I_{C10}$	$V_I > V_{DD}$ $V_I < 0\text{ V}$	-	-	$\pm 400$	
ACZ pins							
27	Rising time	$t_{rs}$	Fig. 1-5-5	30	-	-	$\mu\text{s}$
28	Falling time	$t_{fs}$		30	-	-	

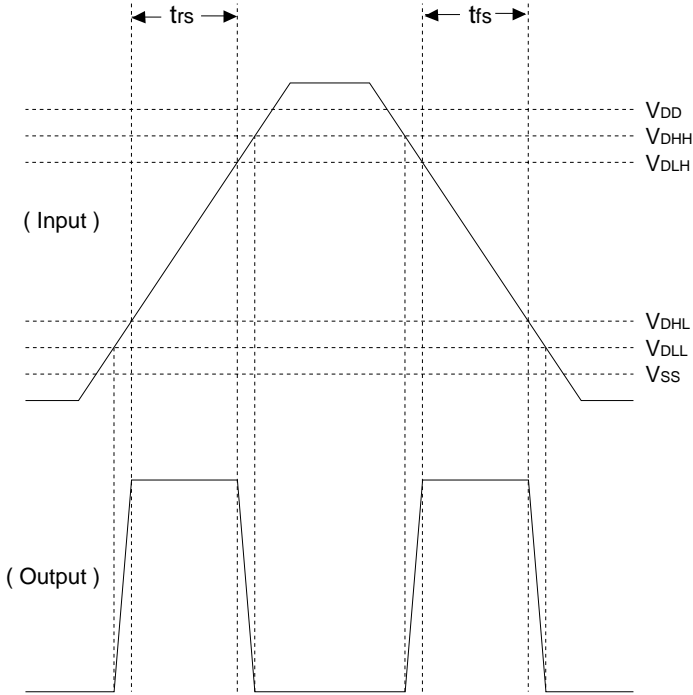


Figure 1-5-5 AC Zero-Cross Detector

Ta=-40 °C to +85 °C(-20 °C to +70 °C) V<sub>DD</sub>=2.0 V (2.7 V) to 5.5 V V<sub>SS</sub>=0 V  
 EPROM vers. is in ( ).

Parameter	Symbol	Conditions	Rating			Unit	
			MIN	TYP	MAX		
Input pin 4 PA 0 to PA 7							
29	Input high voltage 1	V <sub>IH5</sub>		0.8 V <sub>DD</sub>	-	V <sub>DD</sub>	V
30	Input high voltage 2	V <sub>IH6</sub>	V <sub>DD</sub> =4.5 V to 5.5V	0.7 V <sub>DD</sub>	-	V <sub>DD</sub>	
31	Input low voltage 1	V <sub>IL5</sub>		0	-	0.2 V <sub>DD</sub>	
32	Input low voltage 2	V <sub>IL6</sub>	V <sub>DD</sub> =4.5 V to 5.5V	0	-	0.3 V <sub>DD</sub>	
33	Input leakage current	I <sub>LK5</sub>	V <sub>I</sub> =0 V to V <sub>DD</sub>	-	-	± 2	µA
34	Input high current	I <sub>IH5</sub>	V <sub>DD</sub> =5.0 V V <sub>I</sub> =1.5 V Pull-up resistor ON	-30	-100	-300	
35	Input low current	I <sub>IL5</sub>	V <sub>DD</sub> =5.0 V V <sub>I</sub> =3.5 V Pull-down resistor ON	30	100	300	
I/O pin 5 P27 (NRST)							
36	Input high voltage	V <sub>IH7</sub>		0.8 V <sub>DD</sub>	-	V <sub>DD</sub>	V
37	Input low voltage	V <sub>IL7</sub>		0	-	0.15V <sub>DD</sub>	
38	Input high current	I <sub>IH7</sub>	V <sub>DD</sub> =5.0 V V <sub>I</sub> =1.5 V Pull-up resistor ON	-30	-100	-300	µA
I/O pin 6 P00 to P07, P10 to P17, P30 to P37, PC0 to PC3, PD0 to PD7 (Schmitt trigger input, except PC0 to PC3)							
39	Input high voltage	V <sub>IH8</sub>		0.8 V <sub>DD</sub>	-	V <sub>DD</sub>	V
40	Input low voltage	V <sub>IL8</sub>		0	-	0.2V <sub>DD</sub>	
41	Input leakage current	I <sub>LK8</sub>	V <sub>I</sub> =0 V to V <sub>DD</sub>	-	-	± 10	µA
42	Input high current	I <sub>IH8</sub>	V <sub>DD</sub> =5.0 V V <sub>I</sub> =1.5 V Pull-up resistor ON	-30	-100	-300	
43	Output high voltage	V <sub>OH8</sub>	V <sub>DD</sub> =5.0 V I <sub>OH</sub> =-0.5 mA	4.5	-	-	V
44	Output low voltage	V <sub>OL8</sub>	V <sub>DD</sub> =5.0 V I <sub>OL</sub> =1.0 mA	-	-	0.5	
I/O pin 7 P40 to P47							
45	Input high voltage 1	V <sub>IH9</sub>		0.8 V <sub>DD</sub>	-	V <sub>DD</sub>	V
46	Input low voltage 1	V <sub>IL9</sub>		0	-	0.2V <sub>DD</sub>	
47	Input leakage current	I <sub>LK9</sub>	V <sub>I</sub> =0 V to V <sub>DD</sub>	-	-	± 10	µA
48	Input high current	I <sub>IH9</sub>	V <sub>DD</sub> =5.0 V V <sub>I</sub> =1.5 V Pull-up resistor ON	-30	-100	-300	
49	Input low current	I <sub>IL9</sub>	V <sub>DD</sub> =5.0 V V <sub>I</sub> =1.5 V Pull-down resistor ON	30	100	300	
50	Output high voltage	V <sub>OH9</sub>	V <sub>DD</sub> =5.0 V I <sub>OH</sub> =0.5 mA	4.5	-	-	V
51	Output low voltage	V <sub>OL9</sub>	V <sub>DD</sub> =5.0 V I <sub>OL</sub> =1.0 mA	-	-	0.5	

$T_a = -40\text{ }^{\circ}\text{C}$  to  $+85\text{ }^{\circ}\text{C}$  (  $-20\text{ }^{\circ}\text{C}$  to  $+70\text{ }^{\circ}\text{C}$  )  $V_{DD} = 2.0\text{ V}$  (2.7 V) to 5.5 V  $V_{SS} = 0\text{ V}$   
 EPROM vers. is in ( ).

Parameter	Symbol	Conditions	Rating			Unit	
			MIN	TYP	MAX		
Input pin 8 P50 to P54, P60 to P67							
52	Input high voltage 1	$V_{IH10}$		0.8 $V_{DD}$	-	$V_{DD}$	V
53	Input high voltage 2	$V_{IH11}$	$V_{DD} = 4.5\text{ V to } 5.5\text{ V}$	0.7 $V_{DD}$	-	$V_{DD}$	
54	Input low voltage 1	$V_{IL10}$		0	-	0.2 $V_{DD}$	
55	Input low voltage 2	$V_{IL11}$	$V_{DD} = 4.5\text{ V to } 5.5\text{ V}$	0	-	0.3 $V_{DD}$	
56	Input leakage current	$I_{LK10}$	$V_I = 0\text{ V to } V_{DD}$	-	-	$\pm 10$	$\mu\text{A}$
57	Input high current	$I_{IH10}$	$V_{DD} = 5.0\text{ V}$ $V_I = 1.5\text{ V}$ Pull-up resistor ON	-30	-100	-300	
58	Output high voltage	$V_{OH10}$	$V_{DD} = 5.0\text{ V}$ $I_{OH} = -0.5\text{ mA}$	4.5	-	-	V
59	Output low voltage	$V_{OL10}$	$V_{DD} = 5.0\text{ V}$ $I_{OL} = 1.0\text{ mA}$	-	-	0.5	
I/O pin 9 P70 to P77							
60	Input high voltage 1	$V_{IH12}$		0.8 $V_{DD}$	-	$V_{DD}$	V
61	Input high voltage 2	$V_{IH13}$	$V_{DD} = 4.5\text{ V to } 5.5\text{ V}$	0.7 $V_{DD}$	-	$V_{DD}$	
62	Input low voltage 1	$V_{IL12}$		0	-	0.2 $V_{DD}$	
63	Input low voltage 2	$V_{IL13}$	$V_{DD} = 4.5\text{ V to } 5.5\text{ V}$	0	-	0.3 $V_{DD}$	
64	Input leakage current	$I_{LK12}$	$V_I = 0\text{ V to } V_{DD}$	-	-	$\pm 10$	$\mu\text{A}$
65	Input high current	$I_{IH12}$	$V_{DD} = 5.0\text{ V}$ $V_I = 1.5\text{ V}$ Pull-up resistor ON	-30	-100	-300	
66	input low current	$I_{IL12}$	$V_{DD} = 5.0\text{ V}$ $V_I = 1.5\text{ V}$ Pull-down resistor ON	30	100	300	
67	Output high voltage	$V_{OH12}$	$V_{DD} = 5.0\text{ V}$ $I_{OH} = -0.5\text{ mA}$	4.5	-	-	V
68	Output low voltage	$V_{OL12}$	$V_{DD} = 5.0\text{ V}$ $I_{OL} = 1.0\text{ mA}$	-	-	0.5	
I/O pin 10 P80 to P87							
69	Input high voltage 1	$V_{IH14}$		0.8 $V_{DD}$	-	$V_{DD}$	V
70	Input high voltage 2	$V_{IH15}$	$V_{DD} = 4.5\text{ V to } 5.5\text{ V}$	0.7 $V_{DD}$	-	$V_{DD}$	
71	Input low voltage 1	$V_{IL14}$		0	-	0.2 $V_{DD}$	
72	Input low voltage 2	$V_{IL15}$	$V_{DD} = 4.5\text{ V to } 5.5\text{ V}$	0	-	0.3 $V_{DD}$	
73	Input leakage current	$I_{LK14}$	$V_I = 0\text{ V to } V_{DD}$	-	-	$\pm 10$	$\mu\text{A}$
74	Input high current	$I_{IH14}$	$V_{DD} = 5.0\text{ V}$ $V_I = 1.5\text{ V}$ Pull-up resistor ON	-30	-100	-300	
75	Output high voltage	$V_{OH14}$	$V_{DD} = 5.0\text{ V}$ $I_{OH} = -0.5\text{ mA}$	4.5	-	-	V
76	Output low voltage	$V_{OL14}$	$V_{DD} = 5.0\text{ V}$ $I_{OL} = 15\text{ mA}$	-	-	1.0	

## 1-5-4 A/D Converter Characteristics

$T_a = -40\text{ }^\circ\text{C}$  to  $+85\text{ }^\circ\text{C}$  ( $-20\text{ }^\circ\text{C}$  to  $+70\text{ }^\circ\text{C}$ )  $V_{DD} = 2.0\text{ V}$  (2.7 V) to 5.0 V  $V_{SS} = 0\text{ V}$   
 EPROM vers. is in ( ).

Parameter	Symbol	Conditions	Rating			Unit	
			MIN	TYP	MAX		
1	Resolution		-	-	10	Bits	
2	Non-linearity error 1	$V_{DD} = 5.0\text{ V}$ $V_{SS} = 0\text{ V}$ $V_{REF+} = 5.0\text{ V}$ $V_{REF-} = 0\text{ V}$ $T_{AD} = 800\text{ ns}$	-	-	$\pm 3$	LSB	
3	Differential non-linearity error 1		-	-	$\pm 3$		
4	Non-linearity error 2	$V_{DD} = 5.0\text{ V}$ $V_{SS} = 0\text{ V}$ $V_{REF+} = 5.0\text{ V}$ $V_{REF-} = 0\text{ V}$ $f_{OSC} = 32.768\text{ kHz}$	-	-	$\pm 5$		
5	Differential non-linearity error 2		-	-	$\pm 5$		
6	Zero transition voltage	$V_{DD} = 5.0\text{ V}$ $V_{SS} = 0\text{ V}$ $V_{REF+} = 5.0\text{ V}$ $V_{REF-} = 0\text{ V}$ $T_{AD} = 800\text{ ns}$	-	30	100	mV	
7	Full-scale transition voltage		-	30	100		
8	A/D conversion time	$T_{AD} = 800\text{ ns}$	9.6	-	-	$\mu\text{s}$	
9		$f_x = 32.768\text{ kHz}$	-	-	183		
10	Sampling time	$f_{OSC} = 8\text{ MHz}$	1.0	-	36		
11		$f_x = 32.768\text{ kHz}$	-	30.5			
12	Reference voltage	$V_{REF+}$	2.0	-	$V_{DD}$	V	
13		$V_{REF-}$	$V_{SS}$	-	3.0		
14	Analog input voltage		$V_{REF-}$	-	$V_{REF+}$		
15	Analog input leakage current	$V_{ADIN} = 0\text{ V}$ to $5.0\text{ V}$ unselected channel	-	-	$\pm 2$	$\mu\text{A}$	
16	Reference voltage pin input leakage current	Ladder resistor OFF $V_{REF-} \leq V_{REF+} \leq V_{DD}$	-	-	$\pm 10$		
17	Ladder resistance	$R_{LADD}$	$V_{DD} = 5.0\text{ V}$	20	50	80	$\text{k}\Omega$

Ratings in 2 to 5 are guaranteed when  $V_{DD} = V_{REF+} = 5.0\text{ V}$ ,  $V_{SS} = V_{REF-} = 0\text{ V}$ .

## 1-5-5 D/A Converter Characteristics

Ta=25 °C VDD=5.0 V VSS=0 V

	Parameter	Symbol	Conditions	Rating			Unit
				MIN	TYP	MAX	
1	Resolution	-	-	-	-	8	Bits
2	Reference voltage low level	DAVSS	-	0	-	1.0	V
3	Reference voltage high level	DAVDD	-	4.0	-	VDD	
4	Zero scale output voltage	VZS	DAVSS=0 V DAVDD=5.0 V D7 to D0=ALL"L"	-0.05	0	0.05	
5	Full scale output voltage	VFS	DAVSS=0 V DAVDD=5.0 V D7 to D0=ALL"H"	4.93	4.98	5.03	
6	Analog output resistance (Minimum reference resistance)	ROAT	-	6	10	14	kΩ
7	Non-linearity error	NLE	DAVSS=1.0 V DAVDD=4.0 V	-	± 0.5	± 1.0	LSB
8	Differential Non-linearity error	DNLE	DAVSS=1.0 V DAVDD=4.0 V	-	± 2.0	± 3.0	
9	Settling time	TSET	External capacitor CL=35 pF All bits are set to ON or OFF.	-	1.5	3.0	μs
10	Reference voltage pin input leakage current	-	-	-	-	± 10	μA

Ratings in 7 and 8 are guaranteed when VDD=DAVDD=5.0 V, VSS=DAVSS=0 V.

# 1-6 Package Dimension

Package Code : QFP100-P-1818B  
 Unit : mm

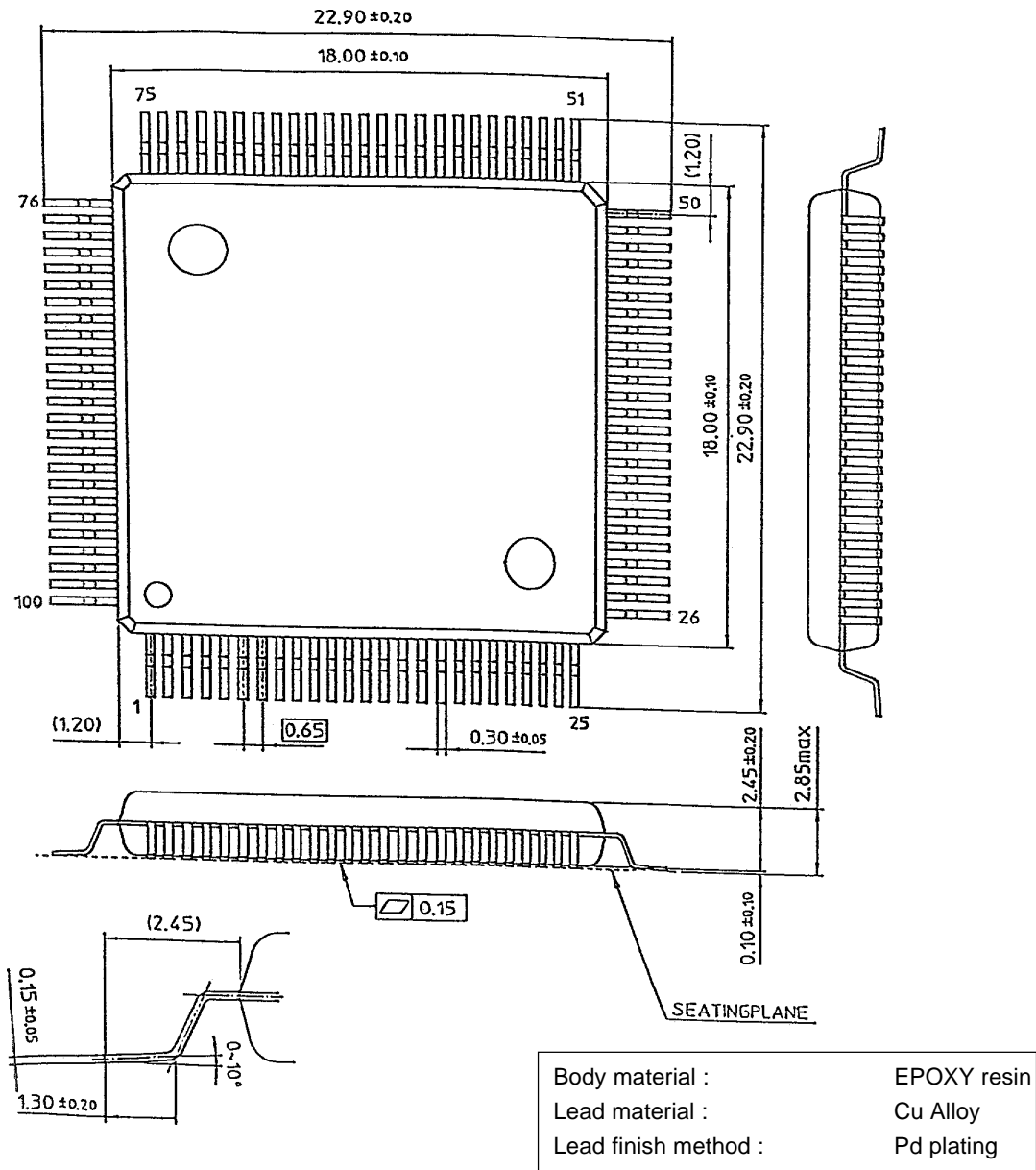



Figure 1-6-1 100-Pin QFP

 The package dimension is subjected to change. Before using this product, please obtain product specifications from the sales office.



Package Code : LQFP100-P-1414

Unit : mm

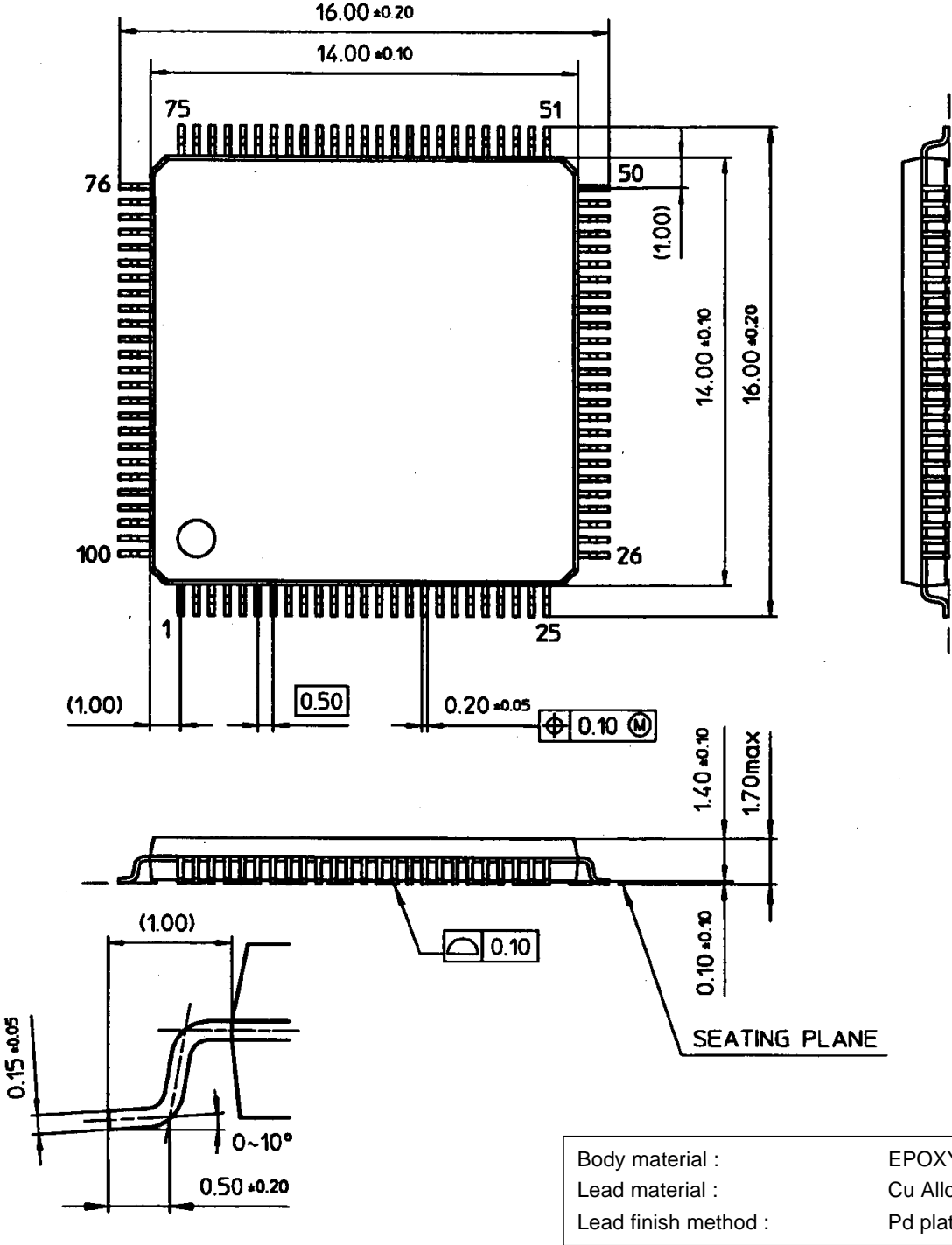


Figure 1-6-2 100-Pin LQFP

## 1-7 Precautions

### 1-7-1 General Usage

#### ■ Connection of VDD pin, and VSS pin

All VDD pins should be connected directly to the power supply and all VSS pins should be connected to ground in the external. Please consider the LSI chip orientation before mounting it on the printed circuit board. Incorrect connection may lead a fusion and break a micro controller.

#### ■ Cautions for Operation

- (1) If you install the product close to high-field emissions (under the cathode ray tube, etc), shield the package surface to ensure normal performance.
- (2) Each model has different operating condition,
  - Operation temperature should be well considered. For example, if temperature is over the operating condition, its operation may be executed wrongly.
  - Operation voltage should be also well considered. If the operation voltage is over the operation range, it can be shortened the length of its life. If the operation voltage is below the operating range, its operation may be executed wrongly.

## 1-7-2 Unused Pins

### ■Unused Pins (only for input)

Insert 10 kΩ to 100 kΩ resistor to unused pins (only for input) for pull-up or pull-down. If the input is unstable, Pch transistor and Nch transistor of input inverter are on, and through current goes to the input circuit. That increases current consumption and causes power supply noise.

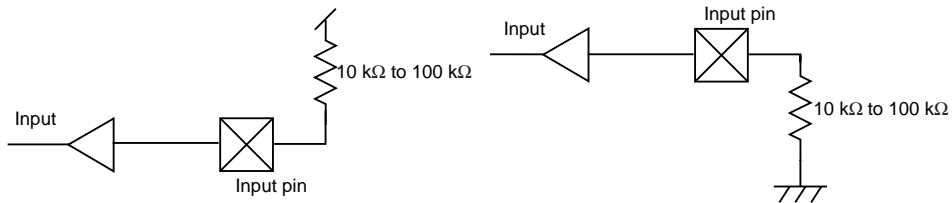


Figure 1-7-1 Unused Pins (only for input)

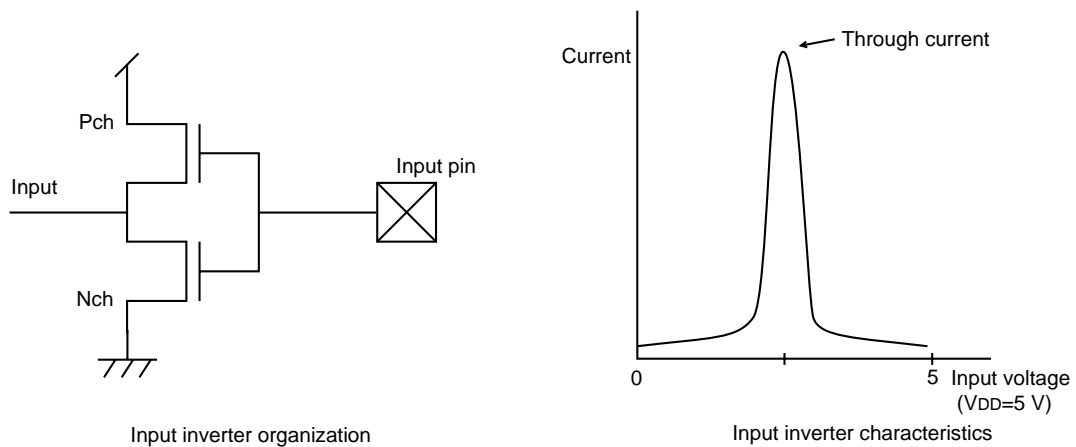


Figure 1-7-2 Input Inverter Organization and Characteristics

■ Unused pins (for I/O)

Unused I/O pins should be set according to pins' condition at reset. If the output is high impedance (Pch / Nch transistor : output off) at reset, to stabilize input, set 10 kΩ to 100 kΩ resistor to be pull-up or pull-down. If the output is on at reset, set them open.

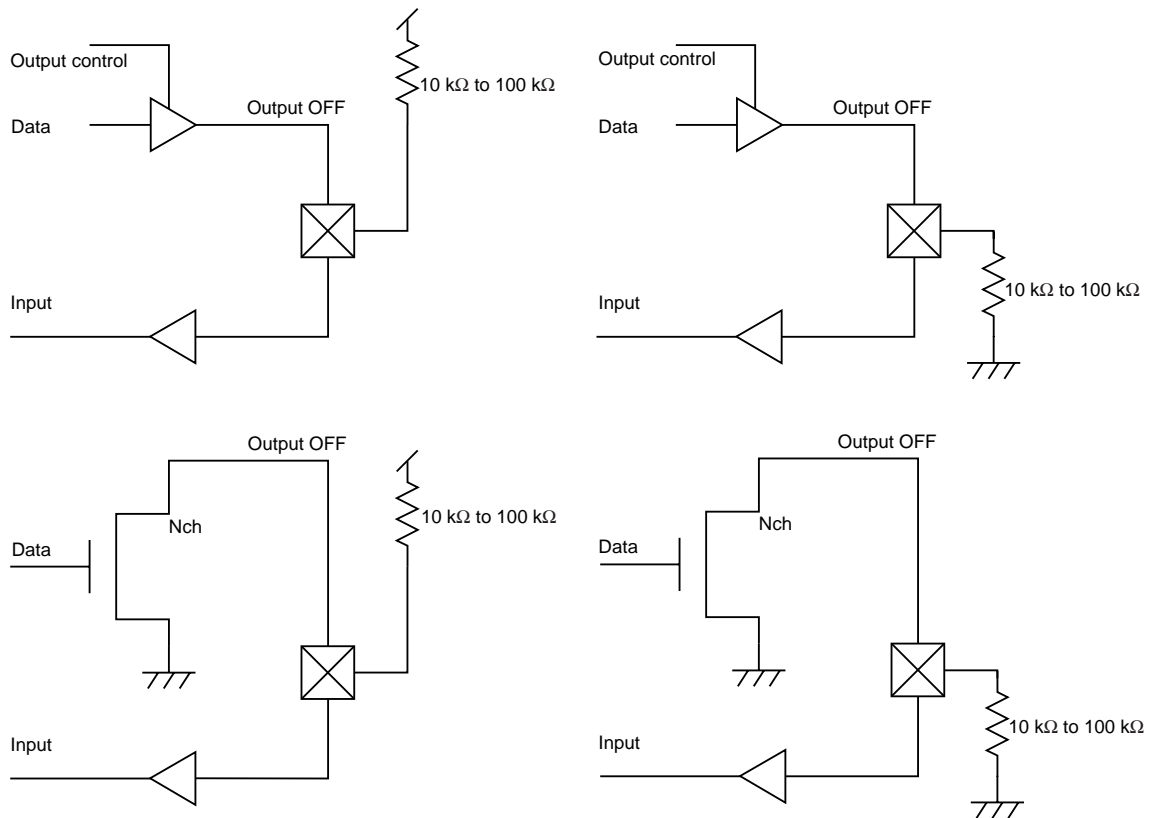


Figure 1-7-3 Unused I/O pins (high impedance output at reset)

### 1-7-3 Power Supply

#### ■The Relation between Power Supply and Input Pin Voltage

Input pin voltage should be supplied only after power supply is on. If the input pin voltage is applied before power supply is on, a latch up occurs and causes the destruction of micro controller by a large current flow.

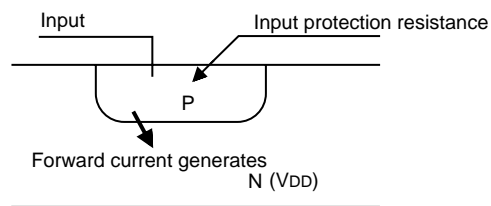
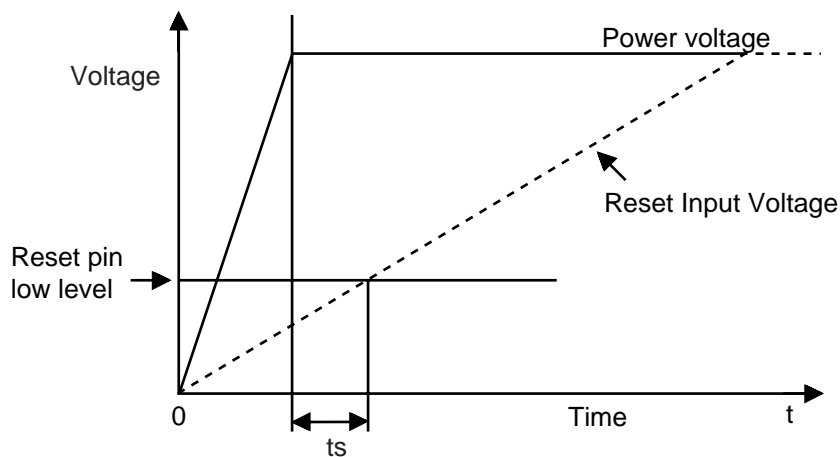


Figure 1-7-4 Power Supply and Input Pin Voltage

#### ■The Relation between Power Supply and Reset Input Voltage

After power supply is on, reset pin voltage should be low for sufficient time,  $t_s$ , before rising, in order to be recognized as a reset signal.




[  Chapter 2. 2-8-1 Reset Operation ]

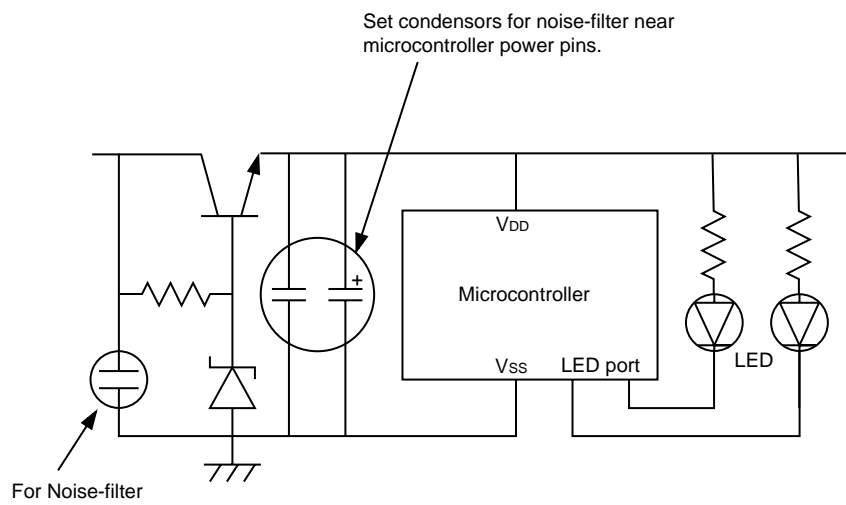
Figure 1-7-5 Power Supply and Reset Input Voltage

## 1-7-4 Power Supply Circuit

### ■Cautions for Setting Power Supply Circuit

The CMOS logic microcontroller is high speed and high density. So, the power circuit should be designed, taking into consideration of AC line noise, ripple caused by LED driver. Figure 1-7-6 shows an example for emitter follower type power supply circuit.

### ■An example for Emitter Follower Type Power Supply Circuit




**Figure 1-7-6 An Example for Emitter follower type Power Supply Circuit**



## 2-1 Overview

The MN101C CPU has a flexible optimized hardware configuration. It is a high speed CPU with a simple and efficient instruction set. Specific features are as follows:

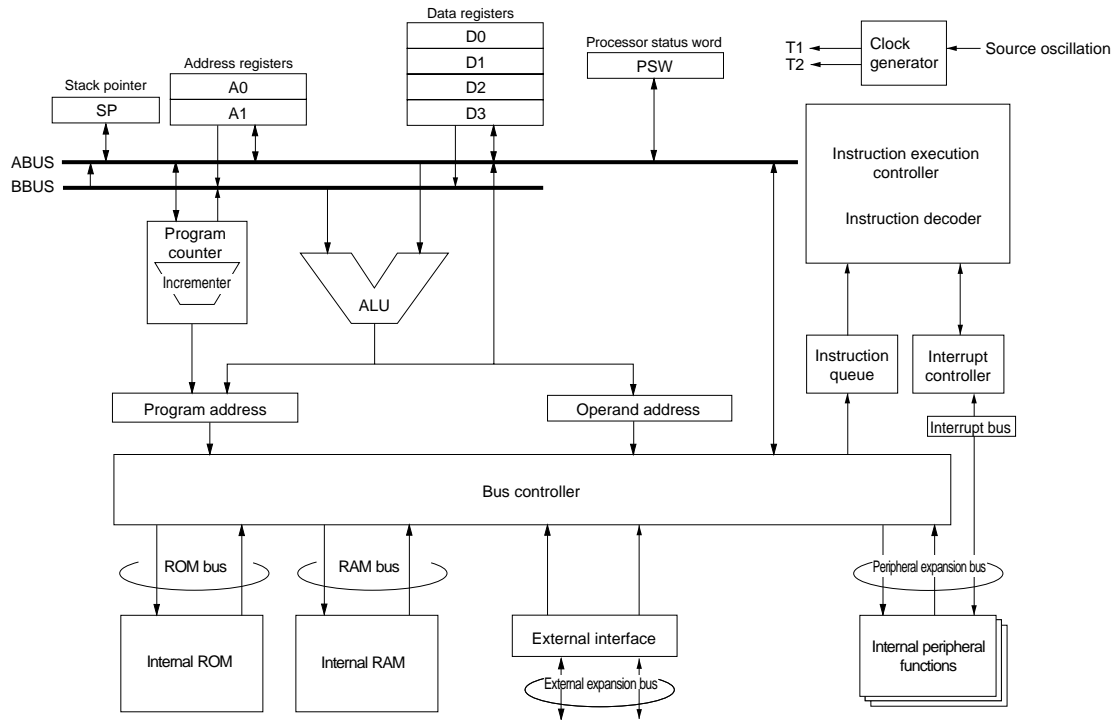
1. Minimized code sizes with instruction lengths based on 4-bit increments  
 The series keeps code sizes down by adopting a basic instruction length of one byte and variable instruction lengths based on 4-bit increments.
2. Minimum execution instruction time is one system clock cycle.
3. Minimized register set that simplifies the architecture and supports C language  
 The instruction set has been determined, depending on the size and capacity of hardware, after an analysis of embedded application programming code and creation code by C language compiler. Therefore, the set is simple instruction using the minimal register set required for C language compiler. [  "MN101C LSI User's Manual" (Architecture Instructions) ]

**Table 2-1-1 Basic Specifications**

Structure	Load / store architecture	
	Six registers	Data : 8-bit x 4 Address : 16-bit x 2
	Other	PC : 19-bit PSW : 8-bit SP : 16-bit
Instructions	Number of instructions	37
	Addressing modes	9
	Instruction length	Basic portion : 1 byte (min.) Extended portion : 0.5-byte x n (0 ≤ n ≤ 9)
Basic performance	Instruction execution	Min. 1 cycle
	Inter-register operation	Min. 2 cycles
	Load / store	Min. 2 cycles
	Conditional branch	2 to 3 cycles
Pipeline	3-stage (instruction fetch, decode, execution)	
Address space	256 KB (max. 64 KB for data)	 2-2 Memory space]
External bus	Address	18-bit (max.)
	Data	8-bit
	Minimum bus cycle	1 system clock cycle
Interrupt	Vector interrupt	3 interrupt levels
Low-power dissipation mode	STOP mode	
	HALT mode	



## 2-1-1 Block Diagram





Clock generator	Uses a clock oscillator circuit driven by an external crystal or ceramic resonator to supply clock signals to CPU blocks.
Program counter	Generates addresses for the instructions to be inserted into the instruction queue. Normally incremented by sequencer indication, but may be set to branch destination address or ALU operation result when branch instructions or interrupts occur.
Instruction queue	Stores up to 2 bytes of pre-fetched instructions.
Instruction decoder	Decodes the instruction queue, sequentially generates the control signals needed for instruction execution, and executes the instruction by controlling the blocks within the chip.
Instruction execution controller	Controls CPU block operations in response to the result decoded by the instruction decoder and interrupt requests.
ALU	Executes arithmetic operations, logic operations, shift operations, and calculates operand addresses for register relative indirect addressing mode.
Internal ROM, RAM	Assigned to the execution program, data and stack region.
Address register	Stores the addresses specifying memory for data transfer. Stores the base address for register relative indirect addressing mode.
Data register	Holds data for operations. Two 8-bit registers can be connected to form a 16-bit register.
Interrupt controller	Detects interrupt requests from peripheral functions and requests CPU shift to interrupt processing.
Bus controller	Controls connection of CPU internal bus and CPU external bus. Includes bus usage arbitration function.
Internal peripheral functions	Includes peripheral functions (timer, serial interface, A/D converter, D/A converter, etc.). Peripheral functions vary with model.

**Figure 2-1-1 Block Diagram and Function**

## 2-1-2 CPU Control Registers

This LSI locates the peripheral circuit registers in memory space (x'03F00' to x'03FFF') with memory-mapped I/O. CPU control registers are also located in this memory space.

**Table 2-1-2 CPU Control Registers**

Registers	Address	R/W	Function	Pages
CPUM	x'03F00'	R/W *1	CPU mode control register	II - 25,29
MEMCTR	x'03F01'	R/W	Memory control register	II - 18
RCCTR	x'03F09'	R/W	ROM correction control register	II - 38
SBNKR	x'03F0A'	R/W	Bank register for source address	II - 32
DBNKR	x'03F0B'	R/W	Bank register for destination address	II - 32
OSCMD	x'03F0D'	R/W	Oscillation frequency control register	II - 29
RCnAP	x'03FC7' to x'03FCF'	R/W	ROM correction address setting register	II - 39, 40
Reserved	x'03FE0'	-	For debugger	-
NMICR	x'03FE1'	R/W	Non - maskable interrupt control register [  Chapter 3 ]	III - 16
xxlCR	x'03FE2' to x'03FFE'	R/W	Maskable interrupt control register [  Chapter 3 ]	III - 17 to 38
Reserved	x'03FFF'	-	Reserved ( For reading interrupt vector data on interrupt process)	-

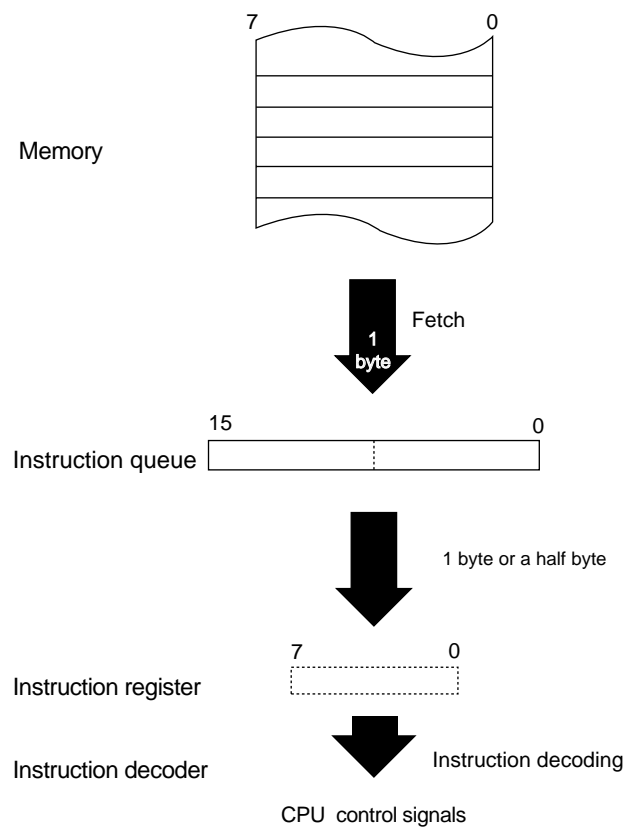
R/W : Readable / Writable

\*1 a part of bit is only readable

### 2-1-3 Instruction Execution Controller

The instruction execution controller consists of four blocks: memory, instruction queue, instruction registers, and instruction decoder.

Instructions are fetched in 1-byte units, and temporarily stored in the 2-byte instruction queue. Transfer is made in 1-byte or half-byte units from the instruction queue to the instruction register to be decoded by the instruction decoder.



**Figure 2-1-2 Instruction Execution Controller Configuration**

## 2-1-4 Pipeline Process

Pipeline process means that reading and decoding are executed at the same time on different instructions, then instructions are executed without stopping. Pipeline process makes instruction execution continual and speedy. This process is executed with instruction queue and instruction decoder.

Instruction queue is buffer that fetches the second instruction in advance. That is controlled to fetch the next instruction when instruction queue is empty at each cycle on execution. At the last cycle of instruction execution, the first word (operation code) of executed instruction is stored to instruction register. At that time, the next operand or operation code is fetched to instruction queue, so that the next instruction can be executed immediately, even if register direct (da) or immediate (imm) is needed at the first cycle of the next instruction execution. But on some other instruction such as branch instruction, instruction queue becomes empty on the time that the next operation code to be executed is stored to instruction register at the last cycle. Therefore, only when instruction queue is empty, and direct address (da) or immediate data (imm) are needed, instruction queue keeps waiting for a cycle.

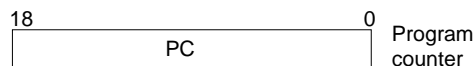
Instruction queue is controlled automatically by hardware so that there is no need to be controlled by software. But when instruction execution time is estimated, operation of instruction queue should be into consideration. Instruction decoder generates control signal at each cycle of instruction execution by micro program control. Instruction decoder uses pipeline process to decode instruction queue at one cycle before control signal is needed.

## 2-1-5 Registers for Address

Registers for address include program counter (PC), address registers (A0, A1), and stack pointer (SP).

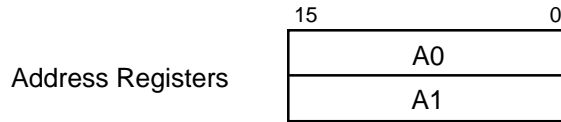
### ■Program Counter (PC)

This register gives the address of the currently executing instruction. It is 19 bits wide to provide access to a 256 KB address space in half byte(4-bit increments). The LSB of the program counter is used to indicate half byte instruction. The program counter after reset is stored from the value of vector table at the address of 4000.



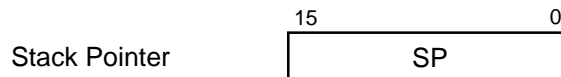
■Address Registers (A0, A1)

These registers are used as address pointers specifying data locations in memory. They support the operations involved in address calculations (i.e. addition, subtraction and comparison). Those pointers are 2 bytes data. Transfers between these registers and memory are always in 16-bit units. Either odd or even address can be transferred. At reset, the value of address register is undefined.



■Stack Pointer (SP)

This register gives the address of the byte at the top of the stack. It is decremented during push operations and incremented during pop operations. At reset, the value of SP is undefined.



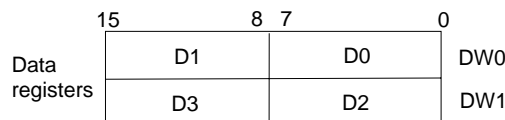
## 2-1-6 Registers for Data

Registers for data include four data registers (D0, D1, D2, D3).

■Data Registers (D0, D1, D2, D3)

Data registers D0 to D3 are 8-bit general-purpose registers that support all arithmetic, logical and shift operations. All registers can be used for data transfers with memory.

The four data registers may be paired to form the 16-bit data registers DW0 (D0+D1) and DW1 (D2+D3). At reset, the value of Dn is undefined.





#### ■Zero Flag (ZF)

Zero flag (ZF) is set to "1", when all bits are '0' in the operation result. Otherwise, zero flag is cleared to "0".

#### ■Carry Flag (CF)

Carry flag (CF) is set to "1", when a carry from or a borrow to the MSB occurs. Carry flag is cleared to "0", when no carry or borrow occurs.

#### ■Negative Flag (NF)

Negative flag (NF) is set to "1" when MSB is '1' and reset to "0" when MSB is '0'. Negative flag is used to handle a signed value.

#### ■Overflow Flag (VF)

Overflow flag (VF) is set to "1", when the arithmetic operation results overflow as a signed value. Otherwise, overflow flag is cleared to "0".

Overflow flag is used to handle a signed value.

#### ■Interrupt Mask Level (IM1 and IM0)

Interrupt mask level (IM1 and IM0) controls the maskable interrupt acceptance in accordance with the interrupt factor interrupt priority for the interrupt control circuit in the CPU. The two-bit control flag defines levels '0' to '3'. Level 0 is the highest mask level. The interrupt request will be accepted only when the level set in the interrupt level flag (xxxLVn) of the interrupt control register (xxxICR) is higher than the interrupt mask level. When the interrupt is accepted, the level is reset to IM1-IM0, and interrupts whose mask levels are the same or lower are rejected during the accepted interrupt processing.

**Table 2-1-3 Interrupt Mask Level and Interrupt Acceptance**

	Interrupt mask level		Priority	Acceptable interrupt levels
	IM1	IM0		
Mask level 0	0	0	High	Non-maskable interrupt (NMI) only
Mask level 1	0	1	.	NMI, Level 0
Mask level 2	1	0	.	NMI, Level 0 to 1
Mask level 3	1	1	Low	NMI, Level 0 to 2

#### ■Maskable Interrupt Enable (MIE)

Maskable interrupt enable flag (MIE) enables/disables acceptance of maskable interrupts by the CPU's internal interrupt acceptance circuit. A '1' enables maskable interrupts; a '0' disables all maskable interrupts regardless of the interrupt mask level (IM1-IM0) setting in PSW.

This flag is not changed by interrupts.

## 2-1-8 Addressing Modes

The MN101C49K series supports the nine addressing modes.

Each instruction uses a combination of the following addressing modes.

- 1) Register direct
- 2) Immediate
- 3) Register indirect
- 4) Register relative indirect
- 5) Stack relative indirect
- 6) Absolute
- 7) RAM short
- 8) I/O short
- 9) Handy

These addressing modes are well-suited for C language compilers. All of the addressing modes can be used for data transfer instructions. In modes that allow half-byte addressing, the relative value can be specified in half-byte (4-bit) increments, so that instruction length can be shorter. Handy addressing reuses the last memory address accessed and is only available with the MOV and MOVW instructions. Combining handy addressing with absolute addressing reduces code size. For transfer data between memory, 7 addressing modes ; register indirect, register relative indirect, stack relative indirect, absolute, RAM short, I/O short, handy can be used. For operation instruction, register direct and immediate can be used. Refer to instruction's manual for the MN101C series.



This LSI is designed for 8-bit data access. It is possible to transfer data in 16-bit increments with odd or all even addresses.



Table 2-1-4 Addressing Modes

Addressing mode		Effective address	Explanation
Register direct	Dn/DWn An/SP PSW	-	Directly specifies the register. Only internal registers can be specified.
Immediate	imm4/imm8 imm16	-	Directly specifies the operand or mask value appended to the instruction code.
Register indirect	(An)	$\begin{array}{c} 15 \qquad \qquad 0 \\ \boxed{\text{An}} \end{array}$	Specifies the address using an address register.
Register relative indirect	(d8, An)	$\begin{array}{c} 15 \qquad \qquad 0 \\ \boxed{\text{An}+d8} \end{array}$	Specifies the address using an address register with 8-bit displacement.
	(d16, An)	$\begin{array}{c} 15 \qquad \qquad 0 \\ \boxed{\text{An}+d16} \end{array}$	Specifies the address using an address register with 16-bit displacement.
	(d4, PC) (branch instructions only)	$\begin{array}{c} 17 \qquad \qquad 0 \text{ H} \\ \boxed{\text{PC}+d4} \end{array} \quad * 1$	Specifies the address using the program counter with 4-bit displacement and H bit.
	(d7, PC) (branch instructions only)	$\begin{array}{c} 17 \qquad \qquad 0 \text{ H} \\ \boxed{\text{PC}+d7} \end{array} \quad * 1$	Specifies the address using the program counter with 7-bit displacement and H bit.
	(d11, PC) (branch instructions only)	$\begin{array}{c} 17 \qquad \qquad 0 \text{ H} \\ \boxed{\text{PC}+d11} \end{array} \quad * 1$	Specifies the address using the program counter with 11-bit displacement and H bit.
	(d12, PC) (branch instructions only)	$\begin{array}{c} 17 \qquad \qquad 0 \text{ H} \\ \boxed{\text{PC}+d12} \end{array} \quad * 1$	Specifies the address using the program counter with 12-bit displacement and H bit.
	(d16, PC) (branch instructions only)	$\begin{array}{c} 17 \qquad \qquad 0 \text{ H} \\ \boxed{\text{PC}+d16} \end{array} \quad * 1$	Specifies the address using the program counter with 16-bit displacement and H bit.
Stack relative indirect	(d4, SP)	$\begin{array}{c} 15 \qquad \qquad 0 \\ \boxed{\text{SP}+d4} \end{array}$	Specifies the address using the stack pointer with 4-bit displacement.
	(d8, SP)	$\begin{array}{c} 15 \qquad \qquad 0 \\ \boxed{\text{SP}+d8} \end{array}$	Specifies the address using the stack pointer with 8-bit displacement.
	(d16, SP)	$\begin{array}{c} 15 \qquad \qquad 0 \\ \boxed{\text{SP}+d16} \end{array}$	Specifies the address using the stack pointer with 16-bit displacement.
Absolute	(abs8)	$\begin{array}{c} 7 \qquad \qquad 0 \\ \boxed{\text{abs8}} \end{array}$	Specifies the address using the operand value appended to the instruction code. Optimum operand length can be used to specify the address.
	(abs12)	$\begin{array}{c} 11 \qquad \qquad 0 \\ \boxed{\text{abs12}} \end{array}$	
	(abs16)	$\begin{array}{c} 15 \qquad \qquad 0 \\ \boxed{\text{abs16}} \end{array}$	
	(abs18) (branch instructions only)	$\begin{array}{c} 17 \qquad \qquad 0 \text{ H} \\ \boxed{\text{abs18}} \end{array} \quad * 1$	
RAM short	(abs8)	$\begin{array}{c} 7 \qquad \qquad 0 \\ \boxed{\text{abs8}} \end{array}$	Specifies an 8-bit offset from the address x'00000'.
I/O short	(io8)	$\begin{array}{c} 15 \qquad \qquad 0 \\ \boxed{\text{IOTOP}+io8} \end{array}$	Specifies an 8-bit offset from the top address (x'03F00') of the special function register area.
Handy	(HA)	-	Reuses the last memory address accessed and is only available with the MOV and MOVW instructions. Combined use with absolute addressing reduces code size.

\* 1 H: half-byte bit

## 2-2 Memory Space

### 2-2-1 Memory Mode

ROM is the read only area and RAM is the memory area which contains readable/writable data. In addition to these, peripheral resources such as memory-mapped special registers are allocated. The MN101C series supports three memory modes (single chip mode, memory expansion mode, processor mode) in its memory model. Setting of each mode is different.

In single chip mode, the system consists of only internal memory. In memory expansion mode, and processor mode, ROM, RAM and external device for operation can be connected.

Settings for each modes are as follows ;

**Table 2-2-1 Memory Mode Setup**

Memory mode	MMOD pin	EXMEM flag in (MEMCTR register)	EXADV3 to 1 flag in (EXADV register)
Single chip mode	L	0	-
Memory expansion mode	L	1	1
Processor mode	H	-	-

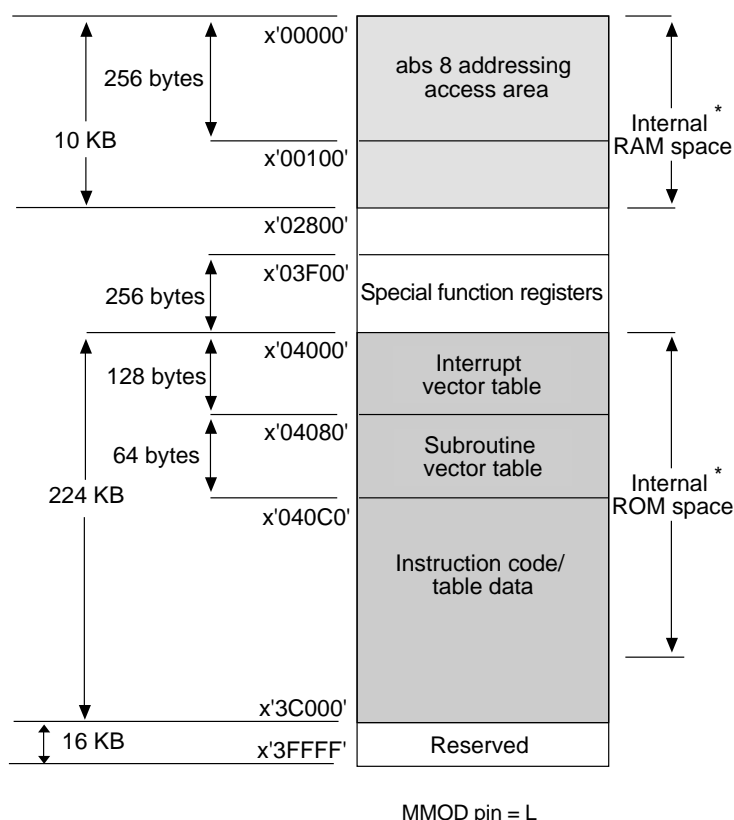


MMOD pin should be fixed to "L" level, or "H" level. Do not change the setup of MMOD pin after reset.

## 2-2-2 Single-chip Mode

In single-chip mode, the system consists of only internal memory. This is the optimized memory mode and allows construction of systems with the highest performance.

The single-chip mode uses only internal ROM and internal RAM. The MN101C series devices offer up to 12 KB of RAM and up to 240 KB of ROM. This LSI offers 10 KB of RAM and 224 KB of ROM.



**Figure 2-2-1 Single-chip Mode**

\*Differs depending upon the model. [  Table 2-2-2. Internal ROM / Internal RAM ]

**Table 2-2-2. Internal ROM / Internal RAM**

Model	Internal RAM		Internal ROM	
	Address	bytes	Address	bytes
MN101C49G	X'00000' to X'00FFF'	4 K	X'04000' to X'23FFF'	128 K
MN101C49H	X'00000' to X'017FF'	6 K	X'04000' to X'2BFFF'	160 K
MN101C49K	X'00000' to X'027FF'	10 K	X'04000' to X'3BFFF'	224 K
MN101CP49K	X'00000' to X'027FF'	10 K	X'04000' to X'3BFFF'	224 K



The value of internal RAM is uncertain when power is applied to it. It needs to be initialized before it is used.

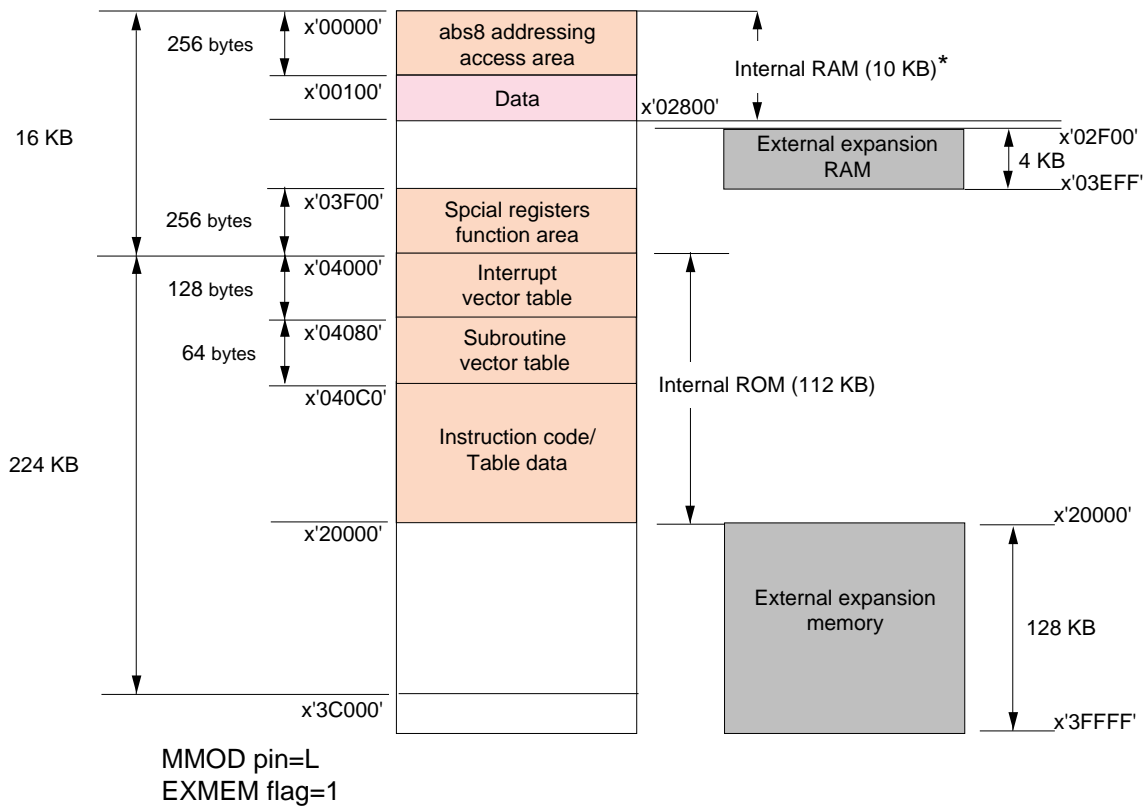
### 2-2-3 Memory Expansion Mode

The MN101C series can connect external ROM, RAM and external devices for operation in memory expansion mode. This is the mode to expand to external memory while using internal ROM and RAM.

The memory expansion mode is set by assigning EXMEM flag (bp4) of the memory control register (MEMCTR), on single chip mode. The address expansion control register(EXADV) controls address output to pins.

Memory areas can be externally expanded as follows :

- ROM: x'20000'-x'3FFFF' (128 KB)
- RAM: x'02F00'-x'03EFF' (4 KB) (no bank switching required)



**Figure 2-2-2 Memory Expansion Mode**

\* Differs depending upon the model. [ Table 2-2-2. Internal ROM / Internal RAM ]

In memory expansion mode, if more than 4KB external RAM area is set, use bank functions.

The value of internal RAM is uncertain when power is applied to it. It needs to be initialized before it is used.

## 2-2-4 Processor Mode

This mode accesses the external expansion ROM and RAM, ignoring any internal ROM present.

For processor mode, set the MMOD pin to high.

Memory areas can be externally expanded as follows:

ROM: x'04000'-x'3FFFF' (240 KB)

RAM: x'02F00'-x'03EFF' (4 KB) (no bank switching required)

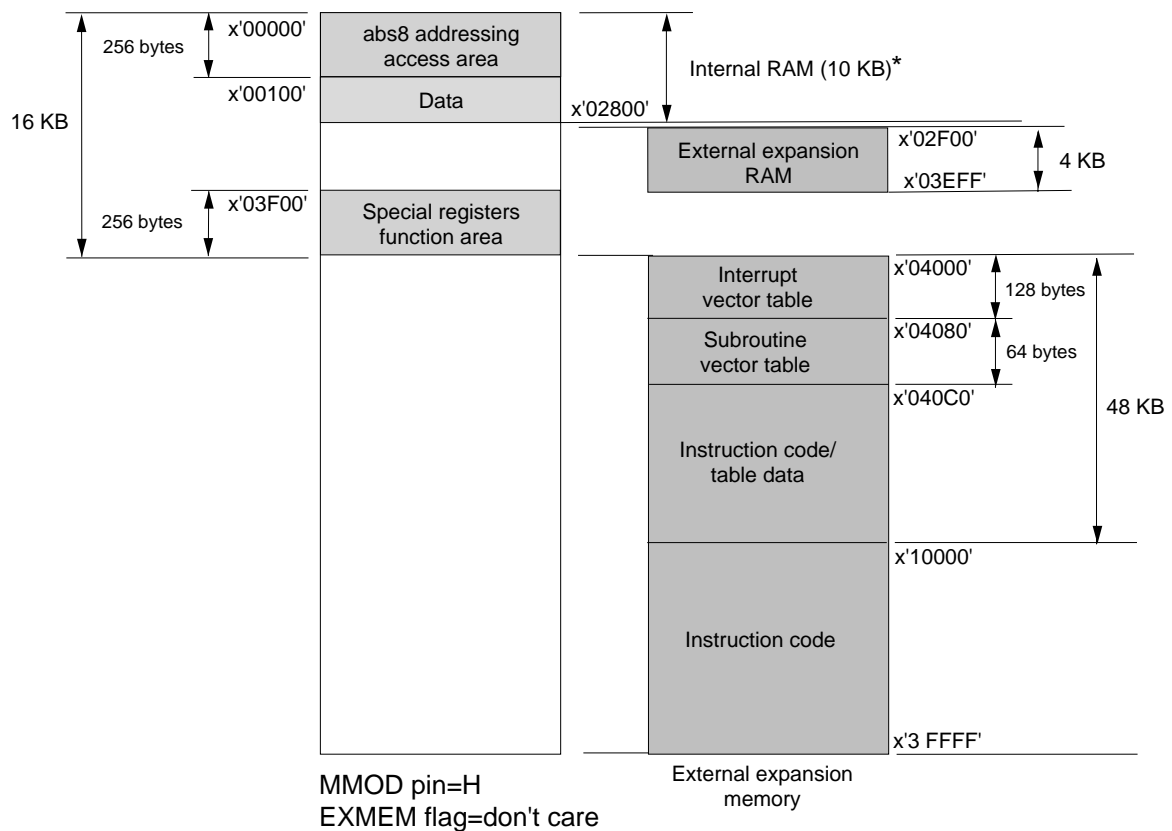


Figure 2-2-3 Processor Mode

\*Differs depending upon the model. [ Table 2-2-2. Internal ROM / Internal RAM ]



In the processor mode, use bank switching when external memory expansion (more than 4 KB) is used.



The value of internal RAM is uncertain when power is applied to it. It needs to be initialized before it is used.

## 2-2-5 Special Function Registers

The MN101C series locates the special function registers (I/O spaces) at the addresses x'03F00' to x'03FFF' in memory space. The special function registers of this LSI are located as shown below.

**Table 2-2-3 Register Map**

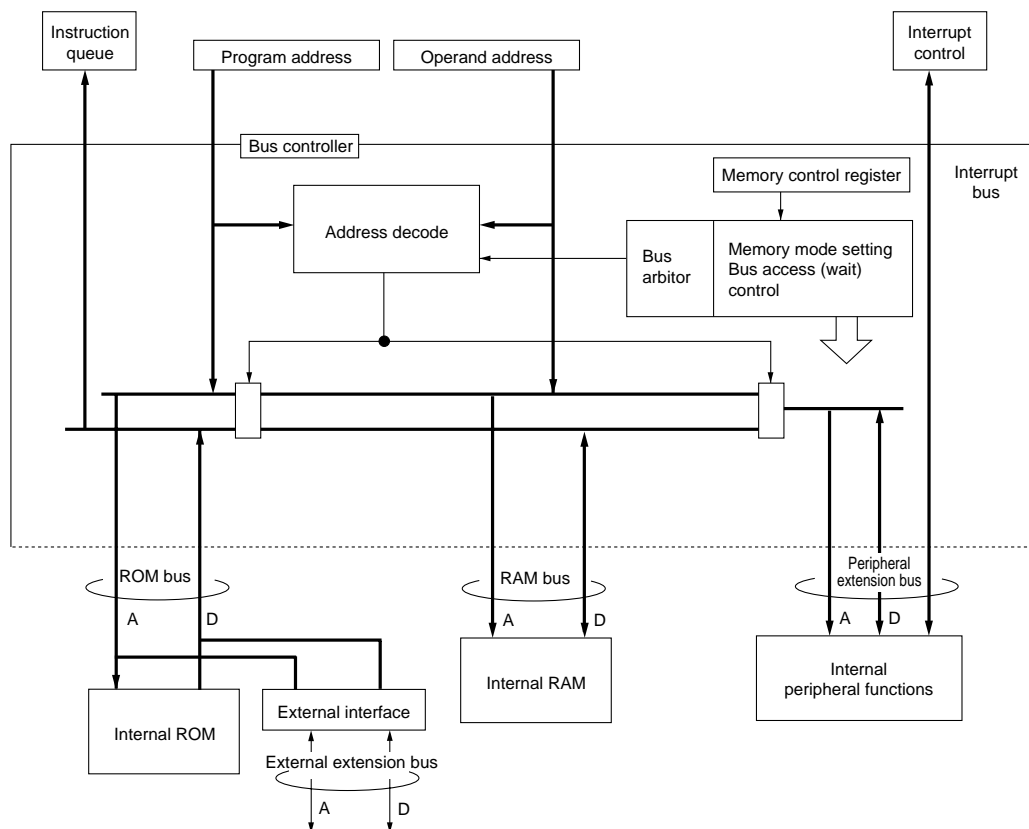
	0	1	2	3	4	5	6	7	8	9	A	B	C	D	E	F	
03F0X	CPUM	MEM CTR	WDCTR	DLYCTR	Reserved		ACTMD			RCCTR	SBNKR	DBNKR		OSCMD	EXADV	Reserved	CPU mode, memory control
03F1X	P0OUT	P1OUT	P2OUT	P3OUT	P4OUT	P5OUT	P6OUT	P7OUT	P8OUT				PCOUT	PDOUT		PDSVO	Port output
03F2X	P0IN	P1IN	P2IN	P3IN	P4IN	P5IN	P6IN	P7IN	P8IN		PAIN		PCIN	PDIN	FLOAT	P10MD	Port input
03F3X	P0DIR	P1DIR		P3DIR	P4DIR	P5DIR	P6DIR	P7DIR	P8DIR		PAMID		PCCIR	PDDIR	P4MD		I/O mode control
03F4X	P0PLU	P1PLU	P2PLU	P3PLU	P4PLU	P5PLU	P6PLU	P7PLU	P8PLU		PAPLUD		PCPLU	PDPLU			Resistor control
03F5X	TM0BC	TM1BC	TM0OC	TM1OC	TM0MD	TM1MD	CK0MD	CK1MD	TM2BC	TM3BC	TM2OC	TM3OC	TM2MD	TM3MD	CK2MD	CK3MD	Timer control
03F6X	TM4BC		TM4OC		CK4MD		CK4MD		TM6BC	TM6OC	TM6MD	TBCLR		RMCTR	PSCMD		
03F7X	TM7BCL	TM7BCH	TM7OC1L	TM7OC1H	TM7PR1L	TM7PR1H	TM7ICL	TM7ICH	TM7MD1	TM7MD2	TM7OC2L	TM7OC2H	TM7PR2L	TM7PR2H	PITCNT		
03F8X															NFCTR	EDGDT	Interrupt I/F control
03F9X	SC0MD0	SC0MD1	SC0MD2	SC0STR	RXBUF0	TXBUF0	SC0ODC	SC0CKS	RXBUF1	TXBUF1	SC1MD0	SC1MD1	SC1MD2	SC1STR	SC1ODC	SC1CKS	Serial I/F control
03FAX	SC2MD0	SC2MD1	SC2TRB				SC2ODC	SC2CKS	SC3MD0	SC3MD1	SC3CTR	SC3TRB			SC3ODC	SC3CKS	
03FBX	ANCTR0	ANCTR1	ANCTR2	ANBUF0	ANBUF1	Reserved						DA2CTR	DA2DR0	DA2DR1	DA2DR2	DA2DR3	Analog I/F control
03FCX	Reserved	Reserved	Reserved	Reserved	Reserved	Reserved	Reserved	RC0APL	RC0APM	RC0APH	RC1APL	RC1APM	RC1APH	RC2APL	RC2APM	RC2APH	ROM correction control
03FDX	AT1CNT0	AT1CNT1	AT1TRC	AT1MAPOL	AT1MAP0M	AT1MAP0H	AT1MAP1L	AT1MAP1M	AT1MAP1H								ATC control
03FEX	Reserved	NMICR	IRQ0ICR	IRQ1ICR	IRQ2ICR	IRQ3ICR	IRQ4ICR	IRQ5ICR		TM0ICR	TM1ICR	TM2ICR	TM3ICR	TM4ICR		TM6ICR	Interrupt control
03FFX	TBICR	TM7ICR	T7OC2ICR		SC0RICR	SC0TICR	SC1ICR	SC2ICR	SC3ICR	ADICR	ATC1ICR					Reserved	

## 2-3 Bus Interface

### 2-3-1 Bus Controller

The MN101C series provides separate buses to the internal memory and internal peripheral circuits to reduce bus line loads and thus realize faster operation.

There are four such buses: ROM bus, RAM bus, peripheral expansion bus (I/O bus), and external expansion bus. They connect to the internal ROM, internal RAM, internal peripheral circuits, and external interfaces respectively. The bus control block controls the parallel operation of instruction read and data access, the access speed adjustment for low-speed external devices, and arbitration of bus access when using master devices on the external bus lines. A functional block diagram of the bus controller is given below.



**Figure 2-3-1 Functional Block Diagram of the Bus Controller**

In memory expansion mode or processor mode, the external expansion bus can access external device. Memory control register (MEMCTR) can be used to select the access mode, fixed wait cycle mode or handshake mode. Wait cycle setting to peripheral expansion bus, connected to internal peripheral circuits is available.

## 2-3-2 Control Registers

Bus interface is controlled by 2 registers : the memory control register (MEMCTR) and the expansion address control register (EXADV).

### ■ Memory Control Register (MEMCTR)

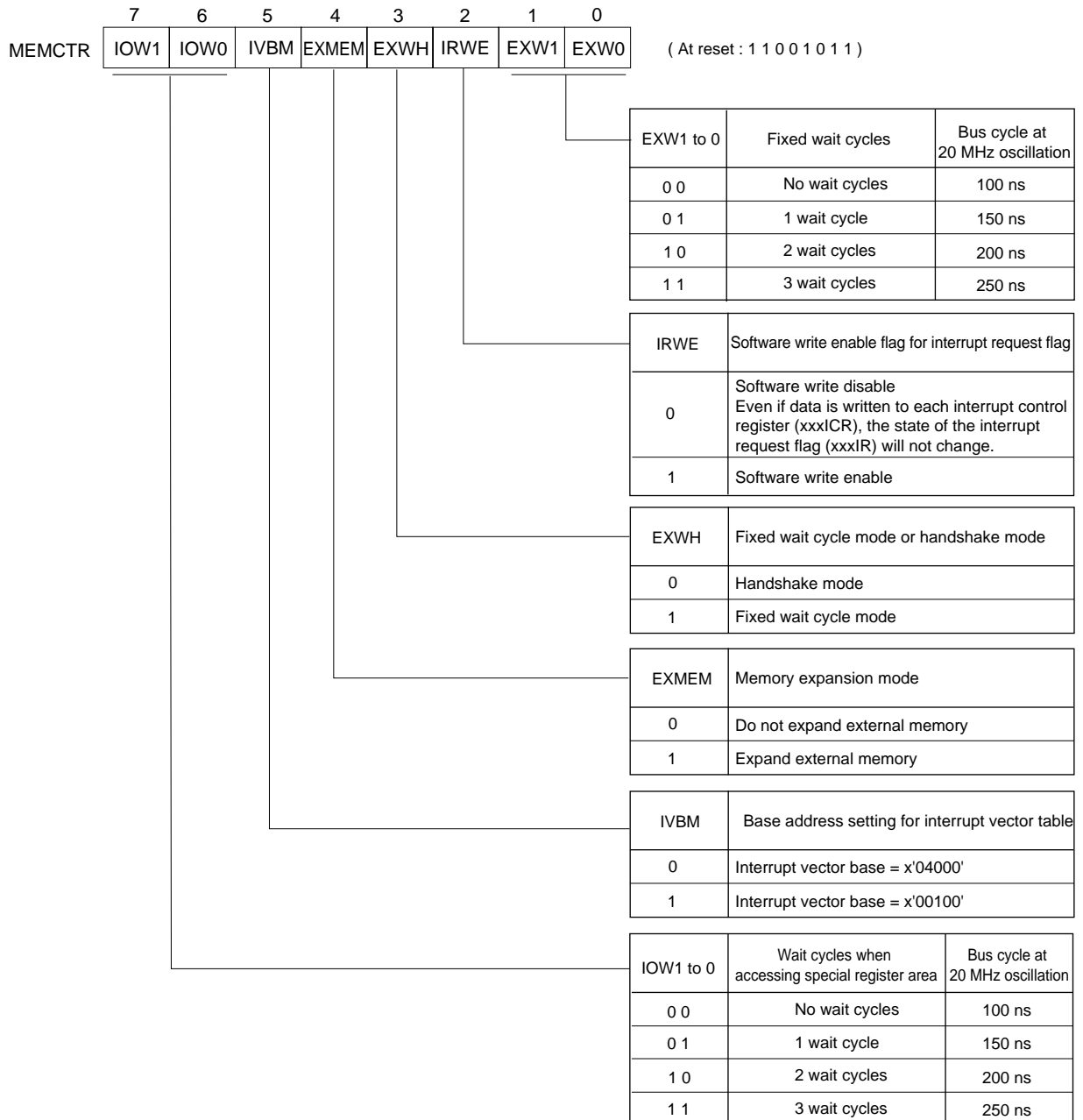


Figure 2-3-2 Memory Control Register (MEMCTR: x'03F01' R/W)





The EXW1-EXW0 wait settings affect accesses to external devices in the processor mode and memory expansion mode. After reset, MEMCTR specifies the fixed wait cycle mode with three wait cycles.



The IOW1-IOW0 wait settings affect accesses to the special registers located at the addresses x'3F00'-x'3FFF'. After reset, MEMCTR specifies the fixed wait cycle mode with three wait cycles. Wait setting of IOW is a function, which CPU supports for special use, for example, when special function register or I/O is expanded to external. For this LSI, wait cycle setting is not always necessary. Select "no-wait cycle" for high performance system construction.

### ■Expansion Address Control Register (EXADV)

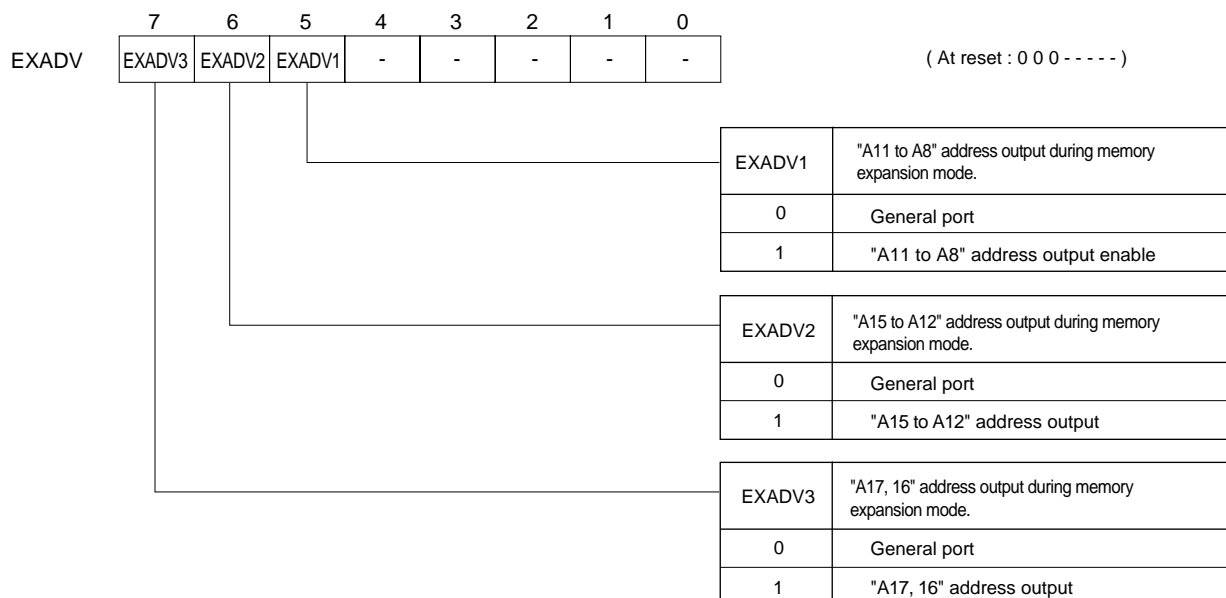


Figure 2-3-3 Expansion Address Control Register (EXADV : x'03F0E', R/W)



In memory expansion mode, unused address pins can be used as general ports.


### 2-3-3 Fixed Wait Cycle Mode

This mode accesses ROM, RAM, or other low-speed devices connected to the external expansion bus by inserting the number of wait cycles specified in the external fixed wait counter (EXW) field of the memory control register (MEMCTR).

Fixed wait cycle mode is used to automatically insert the number of wait cycles specified by the fixed wait counter (EXW1-0) in the MEMCTR. After reset, MEMCTR specifies the fixed wait cycle to three wait cycles. To change to handshake mode or to use a different number, modify the appropriate bits in MEMCTR.

### 2-3-4 Handshake Mode

Handshake mode uses the interlock control method in the data transfer sequence, with a transfer enable signals (NRE, NWE) and a data acknowledge signal (NDK).

Handshake mode adjusts the wait cycle for each external device that has a different access speed when the DK generation circuit is provided for each device. CPU of this LSI keeps waiting until the reception of data acknowledge signal to ensure sufficient wait time so that external device can reception data with no error. [  "MN101C LSI User's Manual" (Architecture Instructions) ]



During single-chip mode, handshake mode can not be used.



On handshake mode, watchdog timer can be used to detect NDK not received error. The reception of NDK is waited until the non-maskable interrupt is generated by the overflow of watchdog timer.

■ Access Timing with No Wait Cycles

The NRE or NWE timing is determined based on OSC2. However, since the delay from OSC1 to RE or WE varies depending upon the product, use NRE or NWE as the reference when synchronizing with other devices. Operation timing is same as the timing when the division factor is 2 (The beginning state after releasing reset) at NORMAL mode (OSC high speed oscillation selection).

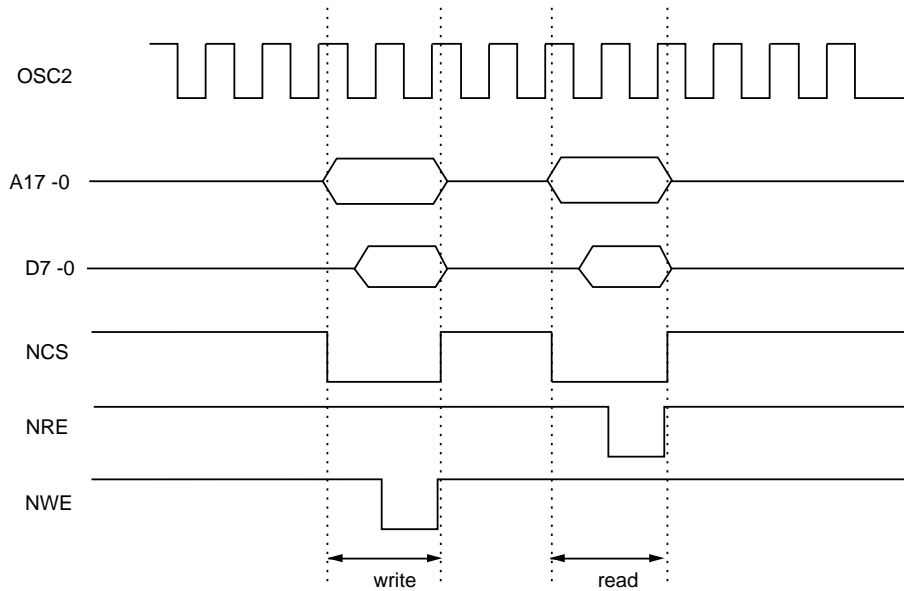


Figure 2-3-4 ROM and RAM Access Timing with No Wait Cycles

■ Access Timing with 1 Wait Cycle

Access timing with 2 or 3 wait cycles follows the same pattern. The latter part of the cycle is extended and the timing is the same.

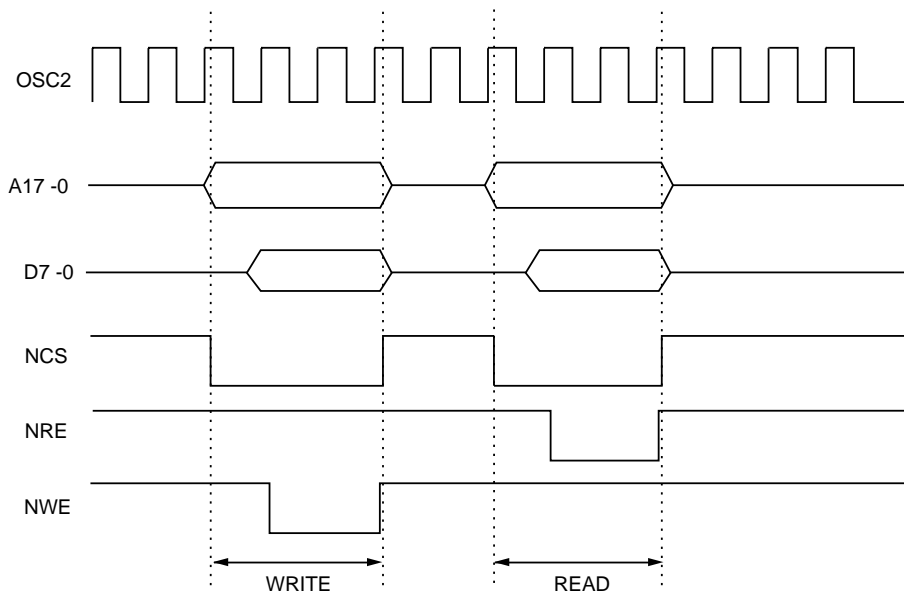


Figure 2-3-5 ROM and RAM Access Timing with 1 Wait Cycle

### 2-3-5 External Memory Connection Example

■ROM Connection Example (processor mode)

This example shows connection to ROM.

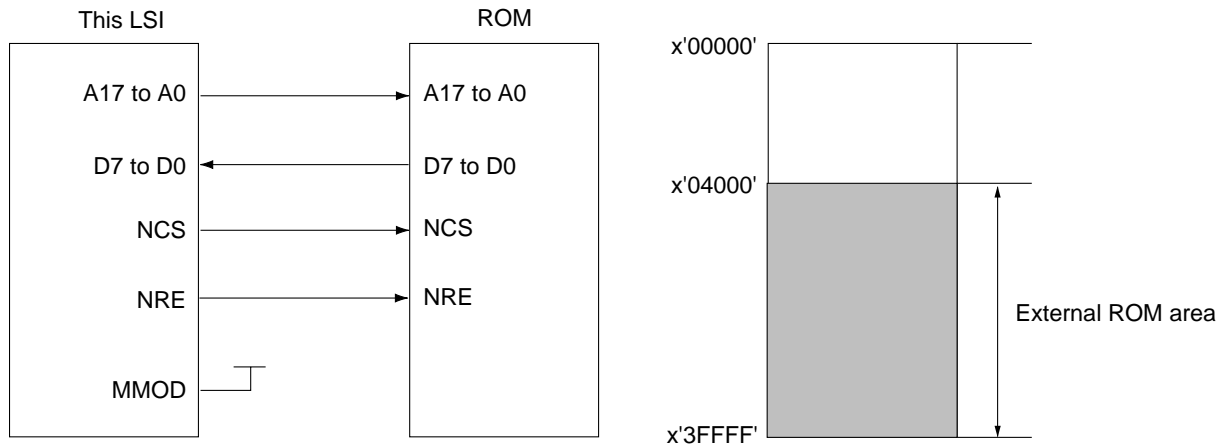


Figure 2-3-6 ROM Connection Example

■SRAM Connection Example

This example shows connection to SRAM.

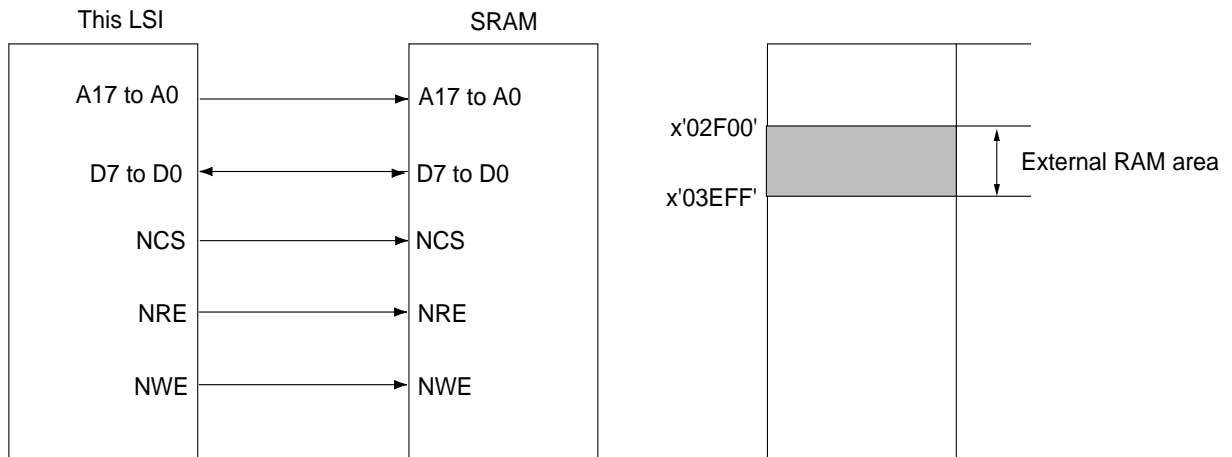


Figure 2-3-7 SRAM Connection Example

## 2-4 Standby Function

### 2-4-1 Overview

This LSI has two sets of system clock oscillator (high speed oscillation, low speed oscillation) for two CPU operating modes (NORMAL and SLOW), each with two standby modes (HALT and STOP). Power consumption can be decreased with using those modes.

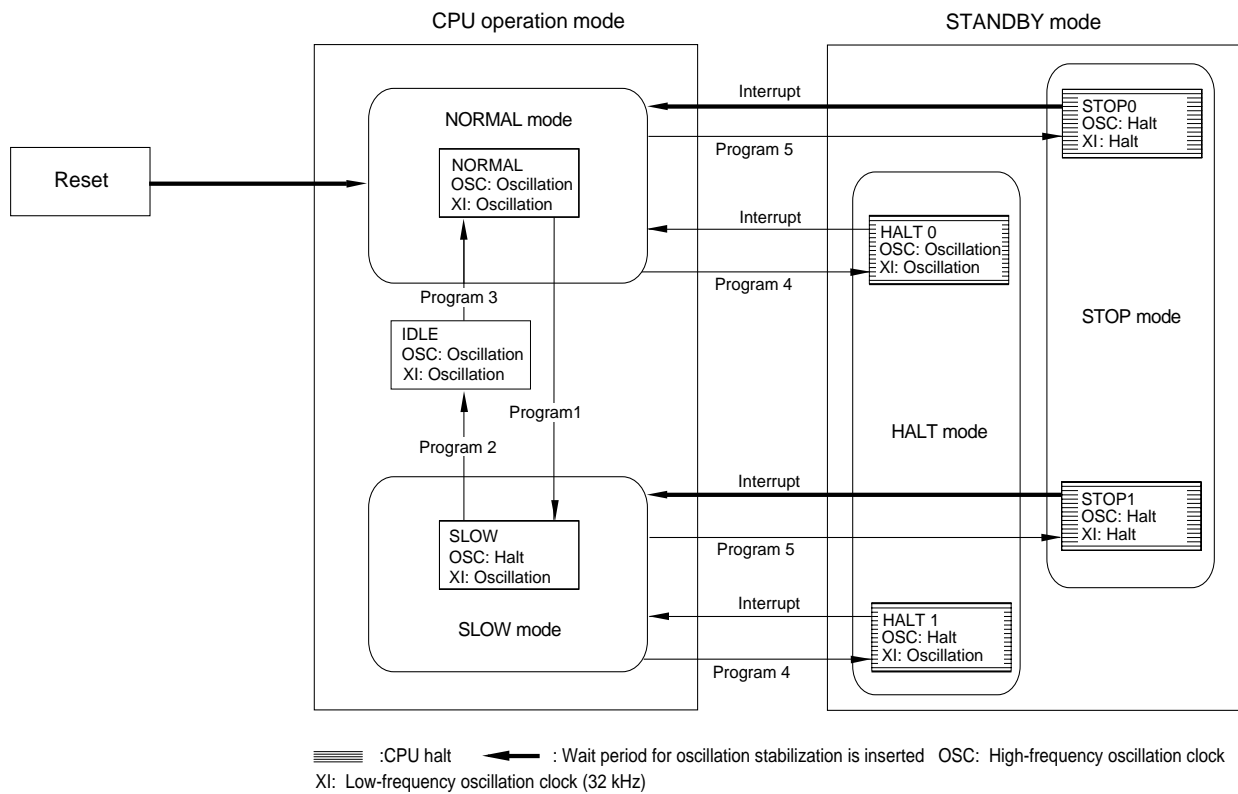


Figure 2-4-1 Transition Between Operation Modes

■ **HALT Modes (HALT0, HALT1)**

- The CPU stops operating. But both of the oscillators remain operational in HALT0 and only the high-frequency oscillator stops operating in HALT1.
- An interrupt returns the CPU to the previous CPU operating mode that is, to NORMAL from HALT0 or to SLOW from HALT1.

■ **STOP Modes (STOP0, STOP1)**

- The CPU and both of the oscillators stop operating.
- An interrupt restarts the oscillators and, after allowing time for them to stabilize, returns the CPU to the previous CPU operating mode - that is, to NORMAL from STOP0 or to SLOW from STOP1.

■ **SLOW Mode**

- This mode executes the software using the low-frequency clock. Since the high-frequency oscillator is turned off, the device consumes less power while executing the software.

■ **IDLE Mode**

- This mode allows time for the high-frequency oscillator to stabilize when the software is changing from SLOW to NORMAL mode.

To reduce power dissipation in STOP and HALT modes, it is necessary to check the stability of both the output current from pins and port level of input pins. For output pins, the output level should match the external level or direction control should be changed to input mode. For input pins, the external level should be fixed.

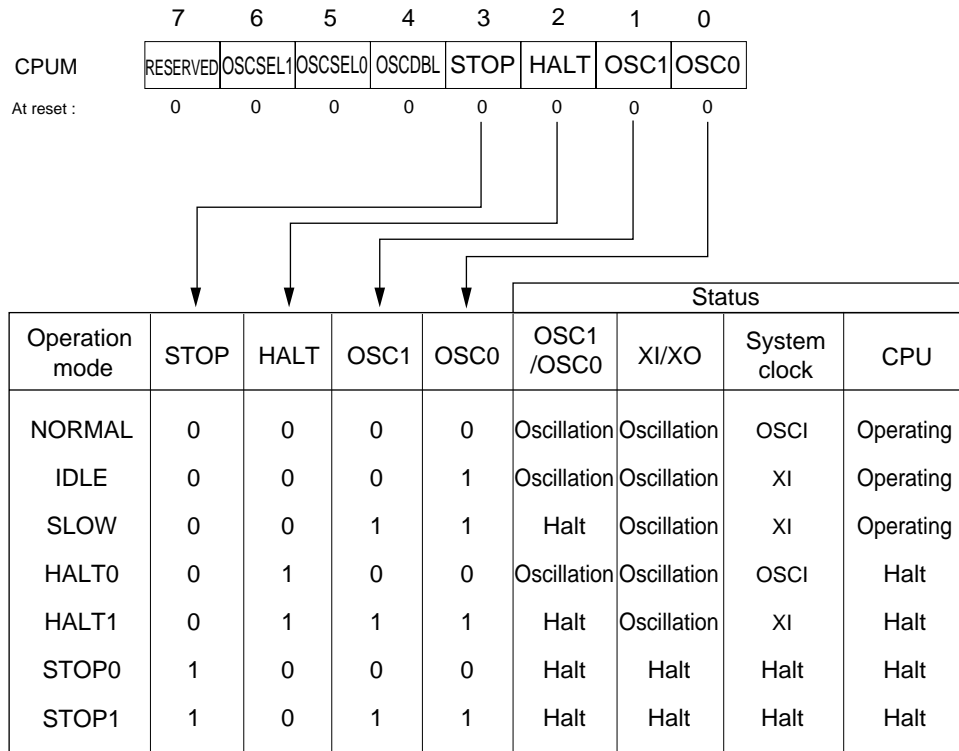
This LSI has two system clock oscillation circuits. OSC is for high-frequency operation (NORMAL mode) and XI is for low-frequency operation (SLOW mode). Transition between NORMAL and SLOW modes or to standby mode is controlled by the CPU mode control register (CPUM). Reset and interrupts are the return factors from standby mode. A wait period is inserted for oscillation stabilization at reset and when returning from STOP mode, but not when returning from HALT mode. High/low-frequency oscillation mode is automatically returned to the same state as existed before entering standby mode.



To stabilize the synchronization at the moment of switching clock speed between high speed oscillation ( $f_{osc}$ ) and low speed oscillation ( $f_x$ ),  $f_{osc}$  should be set to 2.5 times or higher frequency than  $f_x$ .

## 2-4-2 CPU Mode Control Register

Transition from one mode to another mode is controlled by the CPU mode control register (CPUM).



**Figure 2-4-2 Operating Mode and Clock Oscillation (CPUM : x'3F00', R/W)**

The procedure for transition from NORMAL to HALT or STOP mode is given below.


- (1) If the return factor is a maskable interrupt, set the MIE flag in the PSW to "1" and set the interrupt mask (IM) to a level permitting acceptance of the interrupt.
- (2) Clear the interrupt request flag (xxxIR) in the maskable interrupt control register (xxxICR) , set the interrupt enable flag (xxxIE) for the return factor, and set the IE flag in the PSW.
- (3) Set CPUM to HALT or STOP mode.



Set the IRWE flag of the memory control register (MEMCTR) to clear interrupt request flag by software.



System clock (fs) is changed depending on CPU operation mode. In NORMAL mode, HALT0 mode, fs is based on fosc (high speed oscillation). In SLOW mode, IDLE mode, HALT1 mode, fs is based on fx (low speed oscillation).

[  Chapter 2. 2-5 Clock Switching ]

### 2-4-3 Transition between SLOW and NORMAL

This LSI has two CPU operating modes, NORMAL and SLOW. Transition from SLOW to NORMAL requires passing through IDLE mode.

A sample program for transition from NORMAL to SLOW mode is given below.

```

Program 1
  MOV  x'3', D0          ; Set SLOW mode.
  MOV  D0, (CPUM)

```

Transition from NORMAL to SLOW mode, when the low-frequency clock has fully stabilized, can be done by writing to the CPU mode control register. In this case, transition through IDLE is not needed.

For transition from SLOW to NORMAL mode, the program must maintain the idle state until high-frequency clock oscillation is fully stable. In IDLE mode, the CPU operates on the low-frequency clock.



For transition from SLOW to NORMAL, oscillation stabilization waiting time is required same as that after reset. Software must count that time. We recommend selecting the oscillation stabilization time after consulting with oscillator manufacturers.

Sample program for transition from SLOW to NORMAL mode is given below.

```

Program 2
  MOV  x'01', D0        ; Set IDLE mode.
  MOV  D0, (CPUM)

```

```

Program 3
  MOV  x'0B', D0        ; A loop to keep approx. 6.7ms with low-frequency clock (32 kHz)
LOOP  ADD  -1, D0        ; operation when changed to high-frequency clock (20 MHz).
      BNE  LOOP          ;
      SUB  D0, D0        ;
      MOV  D0, (CPUM)    ; Set NORMAL mode.

```



### 2-4-4 Transition to STANDBY Modes

The program initiates transitions from a CPU operating mode to the corresponding STANDBY (HALT/STOP) modes by specifying the new mode in the CPU mode control register (CPUM). Interrupts initiate the return to the former CPU operating mode.

Before initiating a transition to a STANDBY mode, however, the program must

- (1) Set the maskable interrupt enable flag (MIE) in the processor status word (PSW) to '0' to disable all maskable interrupts temporarily.
- (2) Set the interrupt enable flags (xxxIE) in the interrupt control registers (xxxICR) to '1' or '0' to specify which interrupts do and do not initiate the return from the STANDBY mode. Set MIE '1' to enable those maskable interrupts.

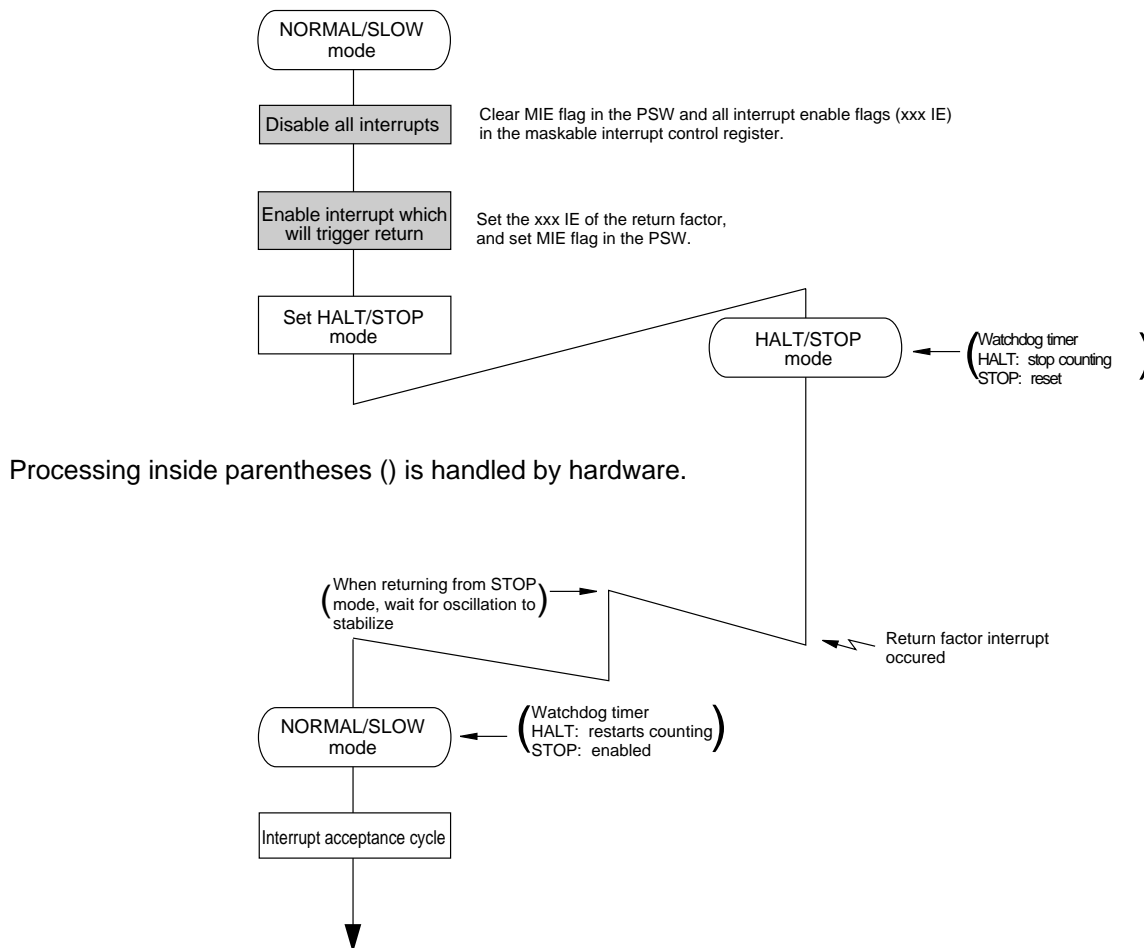


Figure 2-4-3 Transition to/from STANDBY Mode

**!** If the interrupt is enabled but interrupt priority level of the interrupt to be used is not equal to or higher than the mask level in PSW before transition to HALT or STOP mode, it is impossible to return to CPU operation mode by maskable interrupt.

■ Transition to HALT modes

The system transfers from NORMAL mode to HALT0 mode, and from SLOW mode to HALT1 mode. The CPU stops operating, but the oscillators remain operational. There are two ways to leave a HALT mode: a reset or an interrupt. A reset produces a normal reset; an interrupt, an immediate return to the CPU state prior to the transition to the HALT mode. The watchdog timer, if enabled, resumes counting.

```

Program 4
MOV      x'4', D0      ; Set HALT mode.
MOV      D0, (CPUM)
NOP
NOP      ; After written in CPUM, some NOP
NOP      ; instructions (three or less) are
NOP      ; executed.
    
```

■ Transition to STOP mode

The system transfers from NORMAL mode to STOP0 mode, and from SLOW mode to STOP1 mode. In both cases, oscillation and the CPU are both halted. There are two ways to leave a STOP mode: a reset or an interrupt.

```

Program 5
MOV      x'8', D0      ; Set STOP mode
MOV      D0, (CPUM)
NOP
NOP      ; After written in CPUM, some NOP
NOP      ; instructions (three or less) are
NOP      ; executed.
    
```



Right after the instruction of the transition to HALT, STOP mode, NOP instruction should be inserted 3 times.

## 2-5 Clock Switching

This LSI can select the best operation clock for system by switching clock cycle division factor by program. Division factor is determined by both flags of the CPU mode control register (CPUM) and the Oscillator frequency control register (OSCMD). At the highest-frequency, CPU can be operated in the same clock cycle to the external clock hence providing wider operating frequency range.

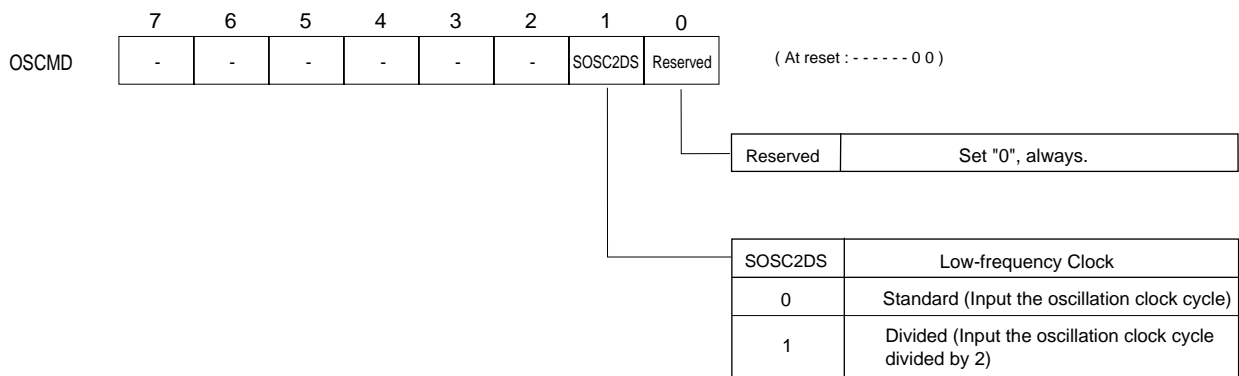


Figure 2-5-1 Oscillator Frequency Control Register (OSCMD : x'03F0D', R/W)

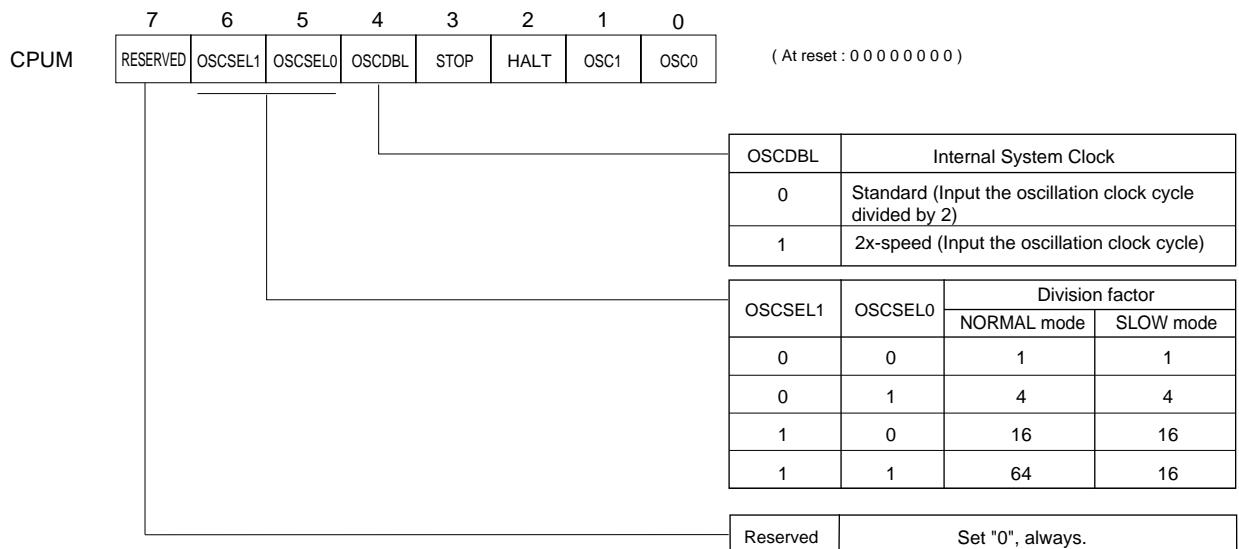


Figure 2-5-2 CPU Mode Control Register (CPUM : x'03F00', R/W)



## 2-6 Bank Function

### 2-6-1 Overview

CPU of MN101C series has basically 64 KB memory address space. On this LSI, address space can be expanded up to 4 banks (256 KB) based on units of 64KB, by bank function. In the expanded space based on bank units, each memory mode (single chip mode, memory expansion mode, processor mode) has a different data access.

### 2-6-2 Bank Setting

Bank function can be used by setting the proper bank area to the bank register for source address (SBNKR) or the bank register for destination address (DBNKR). At reset, both of the SBNKR register and the DBNKR register indicate bank 0. Bank function is valid after setting any value except "00" to the SBNKR register or the DBNKR register.

When the both registers of SBNKR and DBNKR are operated at interrupt processing, pushing onto the stack or popping are necessary.

**Table 2-6-1 Address Range**

SBA1 (DBA1)	SBA0 (DBA0)	Bank area	Address range
0	0	bank 0	x'00000' to x'0FFFF'
0	1	bank 1	x'10000' to x'1FFFF'
1	0	bank 2	x'20000' to x'2FFFF'
1	1	bank 3	x'30000' to x'3FFFF'




When bank area is changed at interrupt processing, pushing onto the stack or popping must be done by program, if it necessary.




The stack area should be set in the area of bank 0, always. Furnished C compiler does not support bank function.

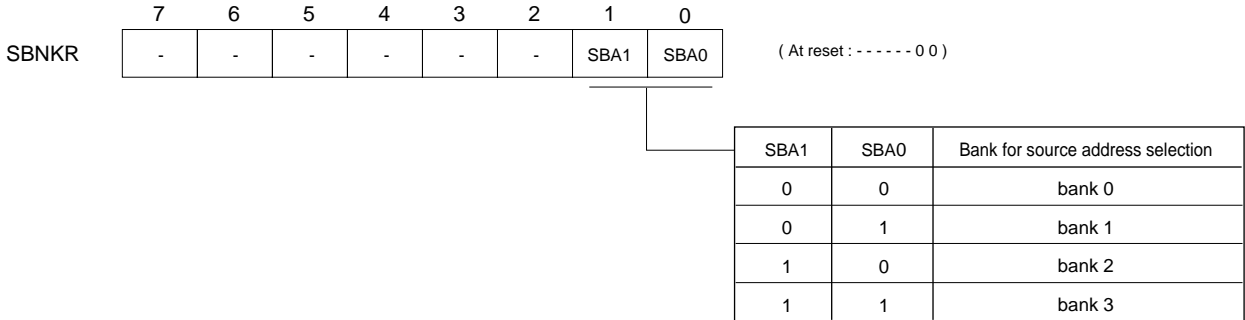


During bank function is valid, I/O short instruction should be used for access to the special function register area (x'03F00' to x'03FFF'). For access to the memory space x'13F00' to x'13FFF', x'23F00' to x'23FFF' and x'33F00' to x'33FFF', both instructions of register indirect and register relative indirect should be used. [  Chapter 2 2-1-8. Addressing Modes]

**Bank Register for Source Address**

The SBNKR register is used to specify bank area for loading instruction from memory to register. Once this register is specified, bank control is valid for all addressing modes except I/O short instruction and stack relative indirect instruction.


[  Chapter 2 2-1-8. Addressing modes ]

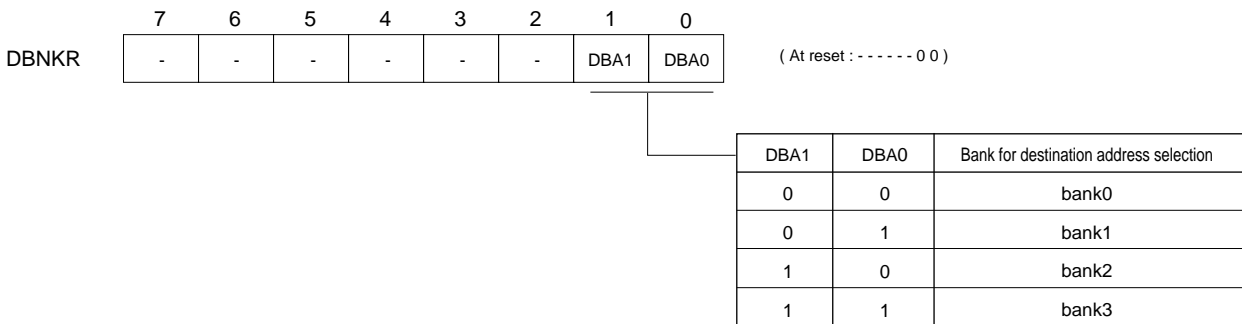


**Figure 2-6-1 Bank Register for Source Address (SBNKR:x'03F0A', R/W)**


**Bank Register for Destination Address**


The DBNKR register is used to specify bank area for storing instruction from register to memory. Once this register is specified, bank control is valid for all addressing modes except I/O short instruction, stack relative indirect instruction and bit manipulation instruction.

[  Chapter 2 2-1-8. Addressing modes ]



**Figure 2-6-2 Bank Register for Destination Address (DBNKR:x'03F0B', R/W)**

 Read, modify, write instruction such as bit manipulation (BSET, BCLR, BTST) depend on the value of the SBNKR register, both of for reading and writing.

 When the memory bank function of the MN101C49 series, EPROM version is used in single-chip mode, set the EXWH, EXW1-0 flags of the memory control register (MEMCTR; x'3F01') as follows;

Set the EXWH (bit3) to "1" (Fixed wait mode)  
Set the EXW1-0 (bit1,0) to "00" (No wait mode)

### 2-6-3 Bank Memory Space

When bank function is used, the memory space, where CPU can access as data, shows as the following hatched part. In the expanded data space based on bank units, each memory mode (single chip mode, memory expansion mode, processor mode) has a different data access.

#### ■Single Chip Mode

In single chip mode used internal ROM and internal RAM, an expanded bank area (bank 1, 2 and a part of bank 3) is in the memory space of internal ROM. In the expanded bank area, reading out of table data is enable, but rewrite is disable.

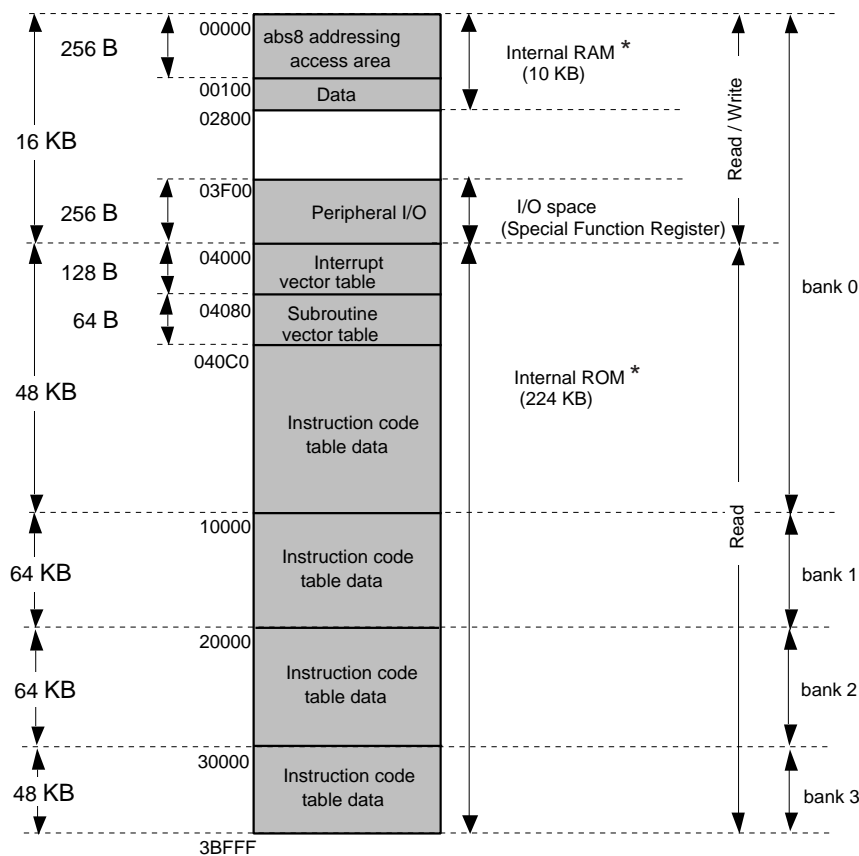


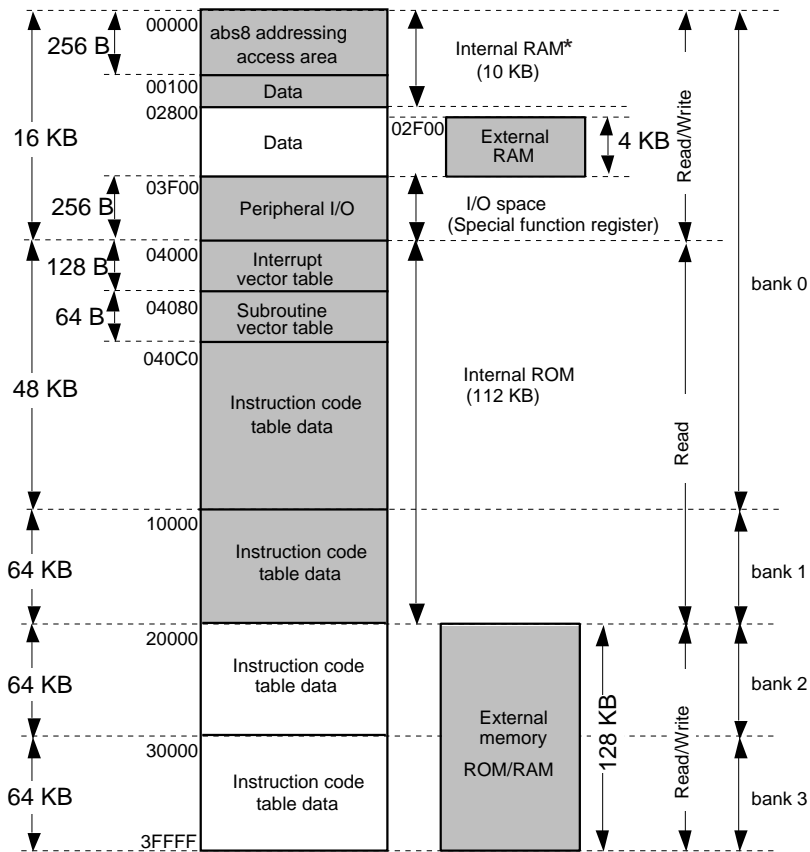
Figure 2-6-3 Single Chip Mode

\*Differs depending upon the model. [  Table 2-2-2. Internal ROM / Internal RAM ]

**Memory Expansion Mode**

In memory expansion mode used internal ROM, internal RAM and external memory (ROM/RAM), each expanded bank area has a different memory space. The area of bank 1 is in the internal ROM space, and the area of bank 2 to 3 is in the external memory (ROM/RAM) space.

In the internal ROM space of bank 1, reading of table data is enable, but rewrite is disable. In the external memory space of bank 2 to 3, both of reading and writing are enable.



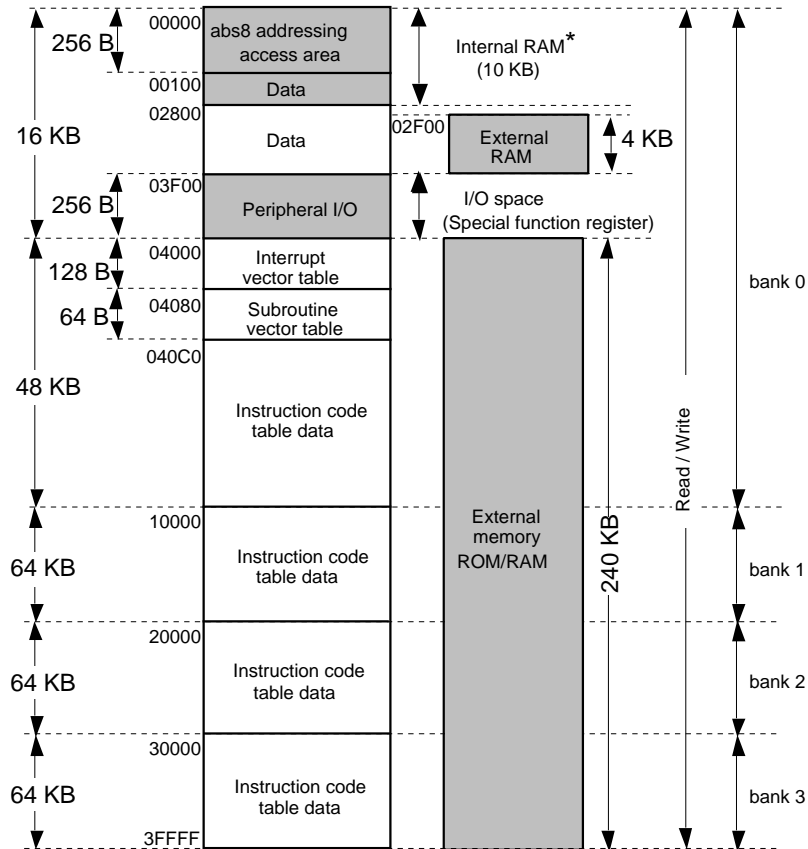
**Figure 2-6-4 Memory Expansion Mode**

\*Differs depending upon the model. [ Table 2-2-2. Internal ROM / Internal RAM ]



**Processor Mode**

In processor mode used internal RAM and the external memory (ROM/RAM), expanded bank area (bank1 to 3) is in the external memory (ROM/RAM) space. In the memory space of the expanded bank, data can be read out and rewrite.



**Figure 2-6-5 Processor Mode**

\*Differs depending upon the model. [  Table 2-2-2. Internal ROM / Internal RAM ]

## 2-7 ROM Correction

### 2-7-1 Overview

This LSI can correct and change max. 3 parts in a program on mask ROM with ROM correction function. The correct program is read from the external to the RAM space by using the external EEPROM or by using the serial transmission. This function is valid to the system with the external EEPROM.

### 2-7-2 Correction Sequence

Program is corrected as following steps.

- (1) The instruction execution address is compared to the correction address.
- (2) Program counter is branched indirectly to the RAM address (the head address of the correct program) stored to the RC vector table (RCnV(L), RCnV(H)), after matching the above addresses.  
This instruction needs 6 cycle.
- (3) The corrected program at the RAM area is executed.
- (4) Program counter is branched back to the program at ROM area.

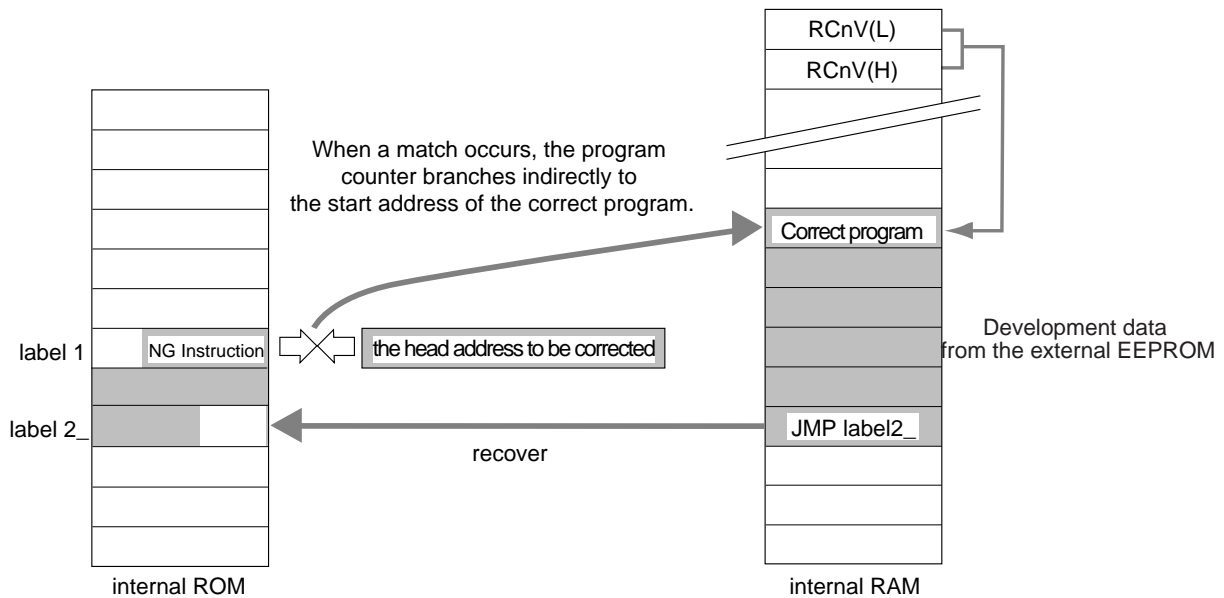


Figure 2-7-1 ROM Correction

The ROM correction setup procedure is as follows.

- (1) Set the head address of the program to be corrected to the ROM correction address setting register (RCnAPH/M/L).
- (2) Set the correct program at RAM area.
- (3) Set the head address of the correct program to RC vector table (RCnV(L), RCnV(H)).
- (4) Set the RCnEN flag of ROM correction control register (RCCTR) to enable the ROM correction.



When the instruction of the corrected program head address is the half-byte instruction, the ROM correction checks the execution instruction of the half-byte. Therefore, set the address by a byte to the ROM correction address setting register.



When the instruction of the corrected program last address is the half-byte instruction, the recover address should be set by half byte.

### 2-7-3 ROM Correction Control Register

ROM correction control register (RCCTR) and ROM correction address setting register (RCnAPL, RCnAPM, RCnAPH) control the ROM correction.

ROM correction control register (RCCTR) enables/disables the ROM correction function to 3 parts of the program to be corrected. When the RCnEN flag is set, the ROM correction is activated. And when the ROM address (the instruction execution address) reaches the set address to the ROM correction address setting register, it branches indirectly to the RAM address set on the RC vector table (RCnV(L), RCnV(H)). Set the RCnEN flag after setting the ROM correction address setting register.

■ROM Correction Control Register(RCCTR)

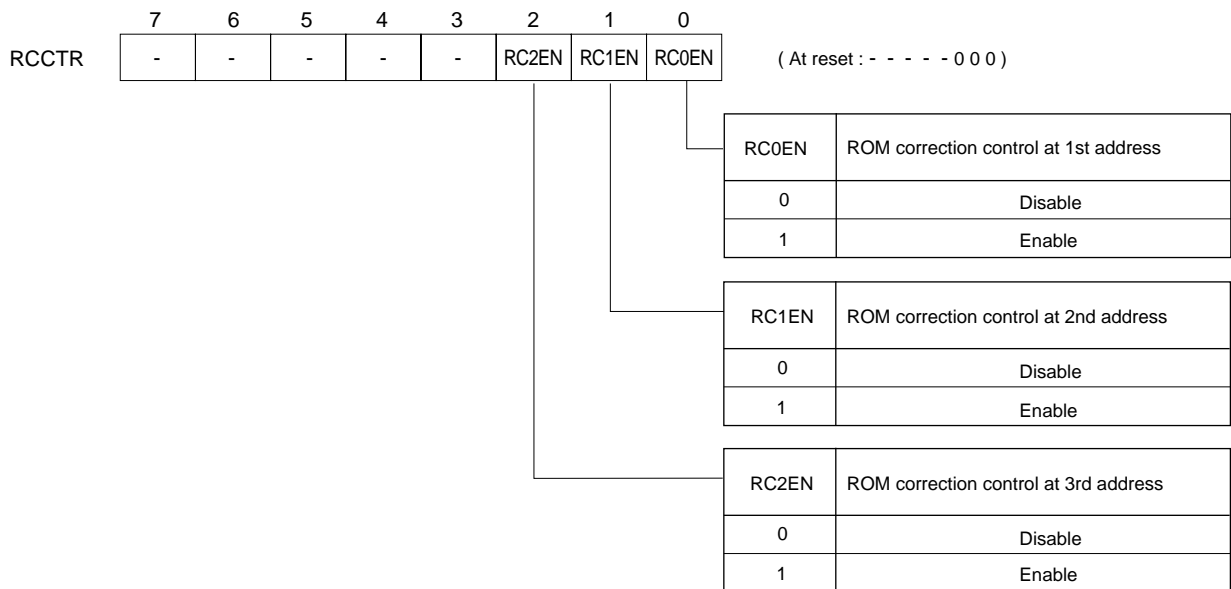
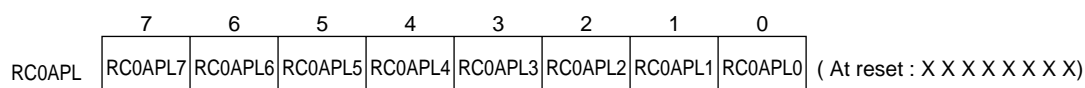


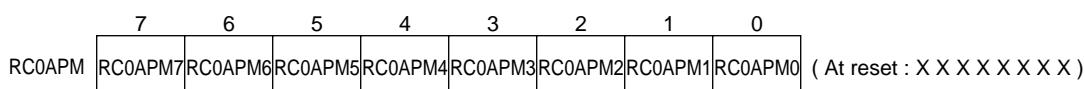
Figure 2-7-2 ROM Correction Control Register (RCCTR : x'03F09', R/W)

This register set the head address, which instructions to be corrected are stored to. Once the instruction execution address reaches to the set value to this register, program counter branches indirectly to the set address to the RC vector table (RCnV(L), RCnV(H)). When the ROM correction should be valid, set the RCnEN flag of the ROM correction control register (RCCTR) after setting the address to this register,.

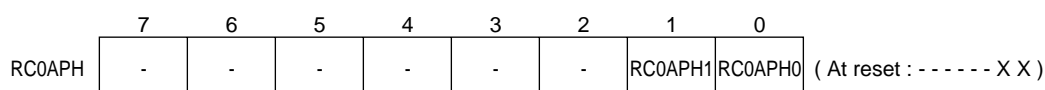
■ROM Correction Address 0 Setting Register (RC0AP)



**Figure 2-7-3 ROM Correction Address 0 Setting Register (lower 8 bits)**  
(RC0APL : x'03FC7', R/W)

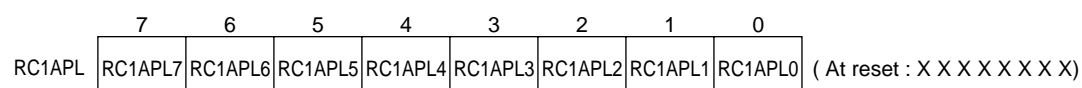


**Figure 2-7-4 ROM Correction Address 0 Setting Register (middle 8 bits)**  
(RC0APM : x'03FC8', R/W)

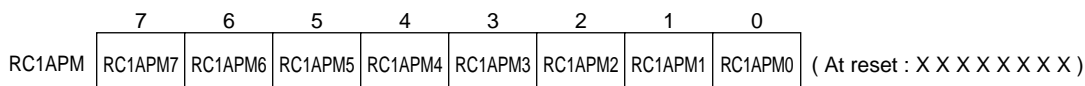


**Figure 2-7-5 ROM Correction Address 0 Setting Register (upper 2 bits)**  
(RC0APH : x'03FC9', R/W)

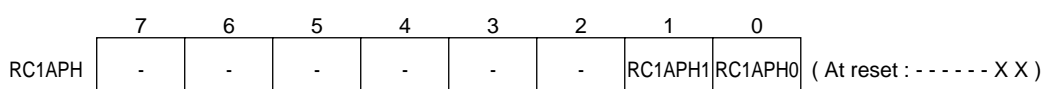
■ROM Correction Address 1 Setting Register (RC1AP)



**Figure 2-7-6 ROM Correction Address 1 Setting Register (lower 8 bits)**  
(RC1APL : x'03FCA', R/W)

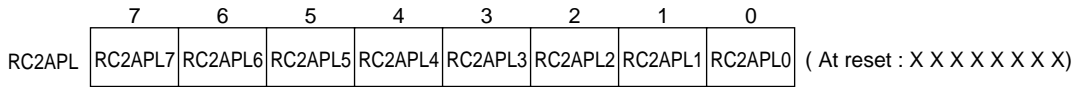


**Figure 2-7-7 ROM Correction Address 1 Setting Register (middle 8 bits)**  
(RC1APM : x'03FCB', R/W)

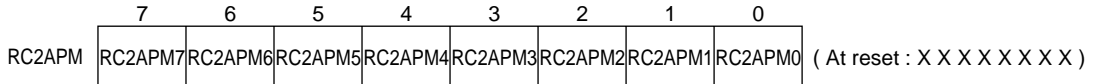


**Figure 2-7-8 ROM Correction Address 1 Setting Register (upper 2 bits)**  
(RC1APH : x'03FCC', R/W)

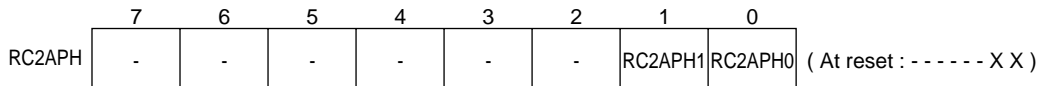
■ROM Correction Address 2 Setting Register (RC2AP)




**Figure 2-7-9 ROM Correction Address 2 Setting Register (lower 8 bits)**  
(RC2APL : x'03FCD', R/W)



**Figure 2-7-10 ROM Correction Address 2 Setting Register (middle 8 bits)**  
(RC2APM : x'03FCE', R/W)



**Figure 2-7-11 ROM Correction Address 2 Setting Register (upper 2 bits)**  
(RC2APH : x'03FCF', R/W)



Do not set the same address to more than two RCnAP (H/M/L) register. If there are several registers set the same address, the order of priority is as follows :

RC0AP > RC1AP > RC2AP

Here is the correspondence of the ROM correction address setting register, a ROM correction control flag of ROM correction control register and the RC vector table.

**Table 2-7-1 Correspondence**

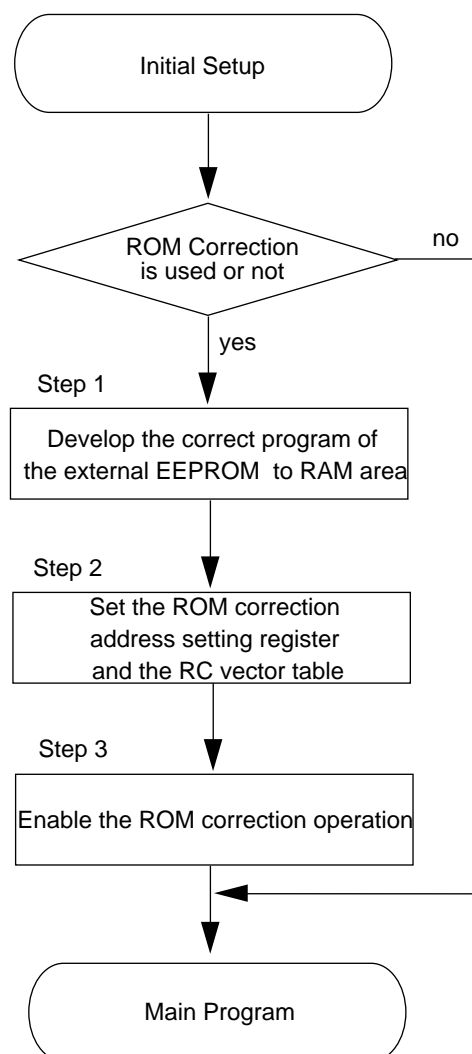
	ROM Correction address setting register		ROM correction control flag	RC-vector table	
	Register	address		vector	address
1st correction	RC0APL	x'3FC7'	RC0EN	RC0V(L)	x'0010'
	RC0APM	x'3FC8'		RC0V(H)	x'0011'
	RC0APH	x'3FC9'			
2nd correction	RC1APL	x'3FCA'	RC1EN	RC1V(L)	x'0012'
	RC1APM	x'3FCB'		RC1V(H)	x'0013'
	RC1APH	x'3FCC'			
3rd correction	RC2APL	x'3FCD'	RC2EN	RC2V(L)	x'0014'
	RC2APM	x'3FCE'		RC2V(H)	x'0015'
	RC2APH	x'3FCF'			

## 2-7-4 ROM Correction Setup Example

### ■Initial Routine with ROM Correction

The following routine should be set to correct the program. Also store the ROM correction setup and the correct program to the external EEPROM, in advance.

Here is the steps for ROM correction execution.

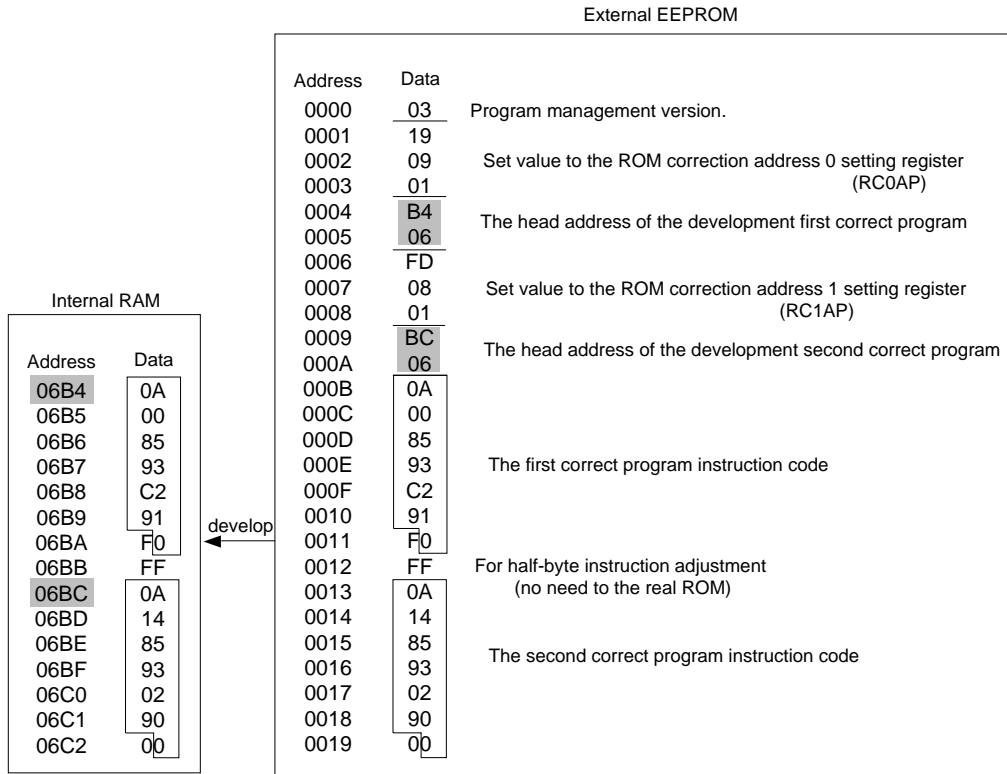


**Figure 2-7-12 Initial Routine for ROM Correction**

■ROM Correction Setup Example

The setup procedure with ROM correction to correct 2 parts of the program is shown below. For the step to execute the ROM correction, refer to figure 2-7-12. Initial Routine for ROM correction on the previous page.

(STEP 1) Develop the correct program of the external EEPROM to RAM area.



(STEP 2) Set the ROM correction address setting register and the RC vector table.

[Setup for the first correction]

Set the head address of the program to be corrected at first to the ROM correction address 0 setting register (RC0AP).

```
RC0APL = x'19'
RC0APM = x'09'
RC0APH = x'01'
```

Set the internal RAM address x'06B4' that stored the first correct program to the RC vector table address (RC0V(L), RC0V(H)).

```
RC0V(L) = x'B4'
RC0V(H) = x'06'
```

The first program to be corrected (internal ROM)

Address	Data	Description
10916	D900A0	cbne 0, d1, 1091E
10919	A005	mov 50, d0
1091B	58	mov d0, (a0)
1091C	8940	bra 10920
1091E	B4	sub d0, d0

The address for recover

The first correct program (internal RAM)

Address	Data	Description
006B4	A000	mov 0, d0
006B6	58	mov d0, (a0)
006B7	392C190	bra 1091C

The address for recover



[Setup for the second correction]

Set the head address of the program to be corrected at second to the ROM correction address 1 setting register (RC1AP).

RC0APL = x'FD'

RC0APM = x'08'

RC0APH = x'01'

Set the internal RAM address x'06BC' that stored the second correct program to the RC vector table address (RC1V(L), RC1V(H)).

RC1V(L) = x'BC'

RC1V(H) = x'06'

The second program to be corrected (internal ROM)

Address	Data	The head address of the correction (the set value of RC1AP)	
108FC	85	sub	d1, d1
108FD	A011	mov	11, d0
108FF	58	mov	d0, (a0)
10900	EC1	addw	1, a0
10901	A081	mov	_Msyscom_edge, 0

The address for recover

The second correct program (internal RAM)

Address	Data	The head address of the correction program (the set value of RC1V)	
006BC	A041	mov	14, d0
006BE	58	mov	d0, (a0)
006BF	3920090	jmp	10900

The address for recover

(STEP 3) Set the bit 0 (RC0EN) and the bit 1 (RC1EN) of the ROM correction control register (RCCTR) to "1".

After the main program is started, the instruction fetched address and the set address to the ROM correction address setting register (RCnAP) are always compared, then once they are matched program counter indirectly branches to the address in RAM area, that are stored to the RC vector table (RCnV).

The correction program in RAM area is executed.

Program counter recovers to the program in ROM area.

## 2-8 Reset

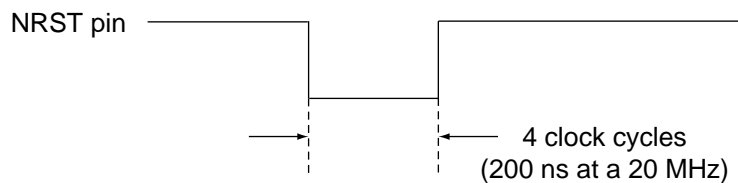
### 2-8-1 Reset operation

The CPU contents are reset and registers are initialized when the NRST pin is pulled to low.

#### ■ Initiating a Reset


There are two methods to initiate a reset.

- (1) Drive the NRST pin low.  
NRST pin should be held "low" for more than OSC 4 clock cycles (200 ns at a 20 MHz).



**Figure 2-8-1 Minimum Reset Pulse Width**

- (2) Setting the P2OUT7 flag of the P2OUT register to "0" outputs low level at P27 (NRST) pin. And transferring to reset by program (software reset) can be executed. If the internal LSI is reset and register is initiated, the P2OUT7 flag becomes "1" and reset is released.

[  Chapter 4. 4-4-2 Registers ]



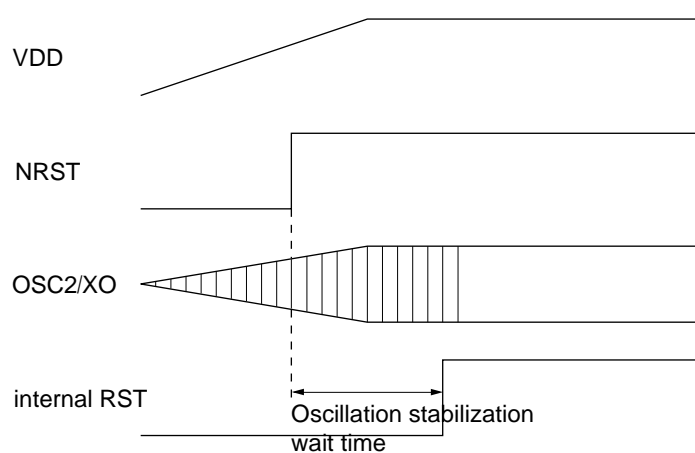
On this LSI, the starting mode is NORMAL mode that high oscillation is the base clock.



When NRST pin is connected to low power voltage detection circuit that gives pulse for enough low level time at sudden unconnected. And reset can be generated even if NRST pin is held "low" for less than OSC 4 clock cycles, take notice of noise.

### ■ Sequence at Reset

- (1) When reset pin comes to high level from low level, the internal 14-bit counter (It can be used as watchdog timer, too.) starts its operation by system clock. The period from starting its count from its overflow is called oscillation stabilization wait time.
- (2) During reset, internal register and special function register are initiated.
- (3) After oscillation stabilization wait time, internal reset is released and program is started from the address written at address X '4000' at interrupt rector table.



**Figure 2-8-2 Reset Released Sequence**

## 2-8-2 Oscillation Stabilization Wait time

Oscillation stabilization wait time is the period from the stop of oscillation circuit to the stabilization for oscillation. Oscillation stabilization wait time is automatically inserted at releasing from reset and at recovering from STOP mode. At recovering from STOP mode the oscillation stabilization wait time control register (DLYCTR) is set to select the oscillation stabilization wait time. At releasing from reset, oscillation stabilization wait time is fixed.

The timer that counts oscillation stabilization wait time is also used as a watchdog timer. That is used as a runaway detective timer at anytime except at releasing from reset and at recovering from STOP mode. Watchdog timer is initiated at reset and at STOP mode and starts counting from the initialize value (x'0000') when system clock (fs) is as clock source. After oscillation stabilization wait time, it continues counting as a watchdog timer. [ Chapter 9 Watchdog timer ]

### Block Diagram of Oscillation Stabilization Wait Time (watchdog timer)

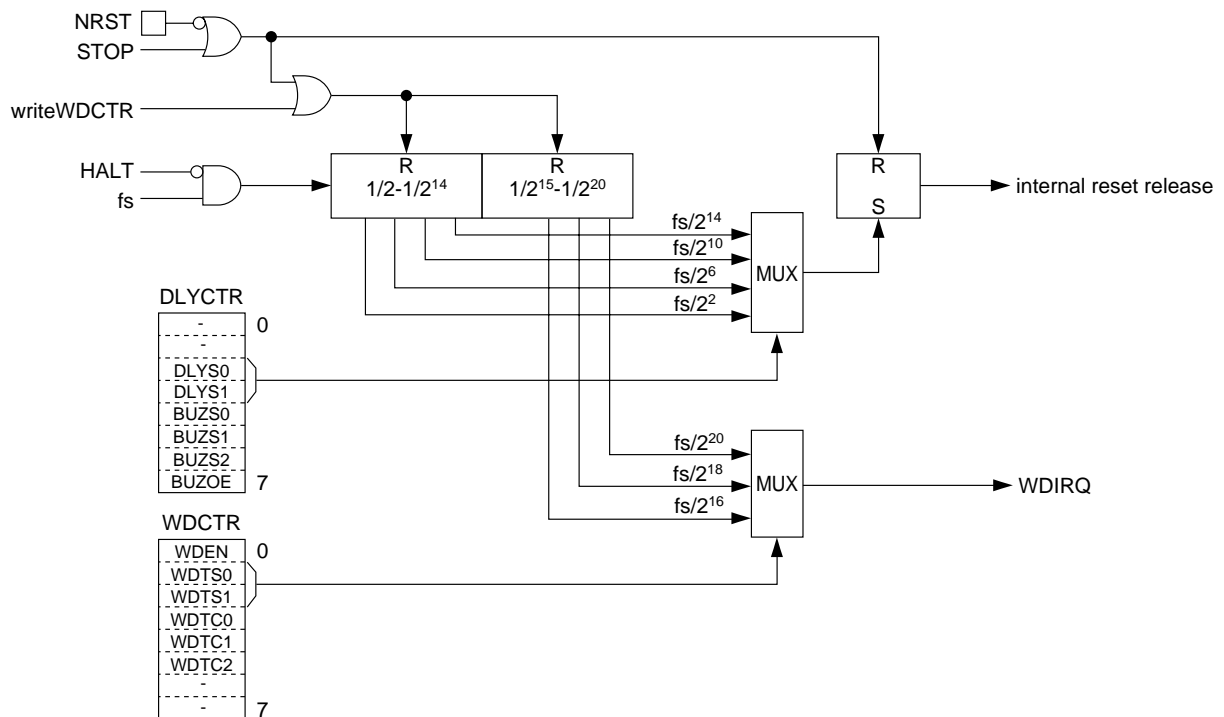
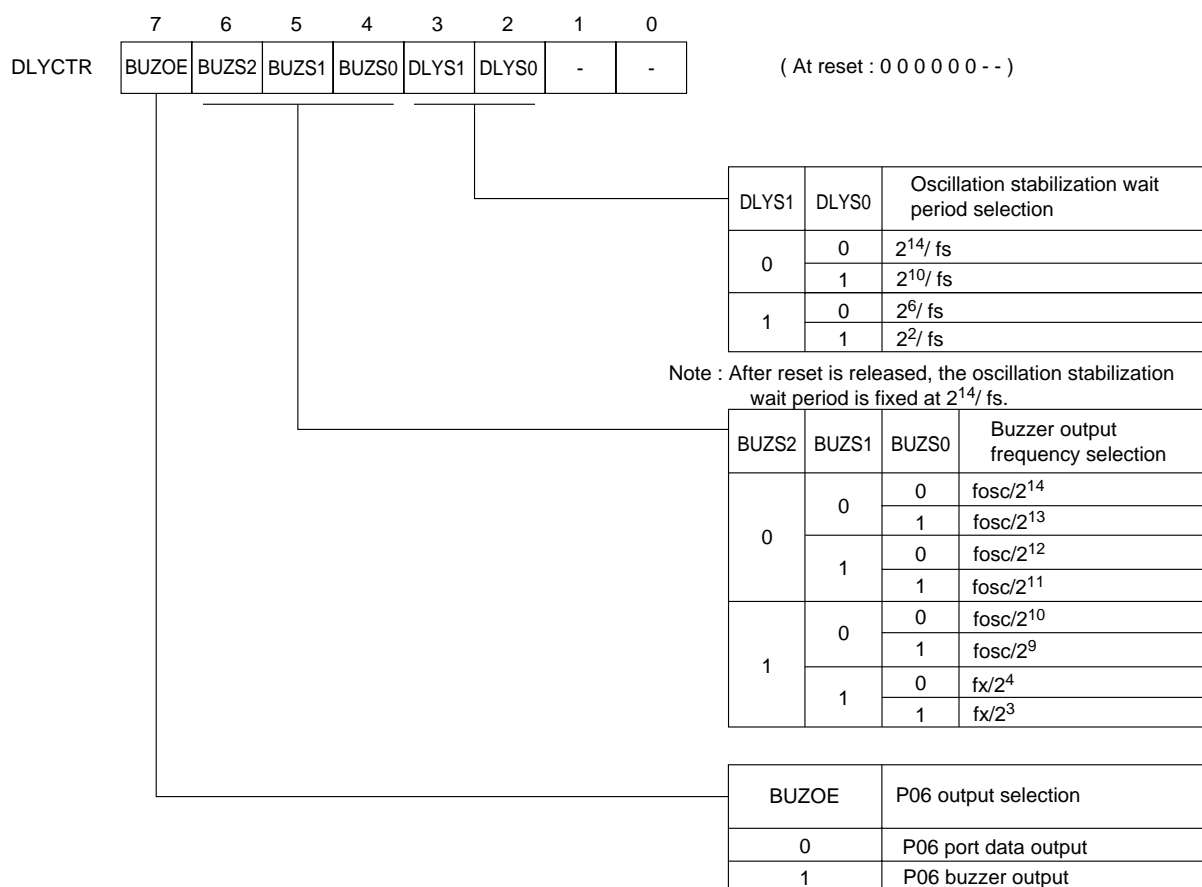


Figure 2-8-3 Block Diagram of Oscillation Stabilization Wait Time (watchdog timer)

### ■ Oscillation Stabilization Wait Time Control Register



**Figure 2-8-4 Oscillation Stabilization Wait Time Control Register (DLYCTR : x'03F03', R/W)**

#### ■ Control the Oscillation Stabilization Wait Time

At recovering from STOP mode, the bit 3-2 (DLYS1, DLYS0) of the oscillation stabilization wait time control register can be set to select the oscillation stabilization wait time from  $2^{14}$ ,  $2^{10}$ ,  $2^6$ ,  $2^2$  x system clock. The DLYCTR register is also used for controlling of buzzer functions.

[ Chapter 10 Buzzer ]

At releasing from reset, the oscillation stabilization wait time is fixed to " $2^{14}$  x system clock". System clock is determined by the CPU mode control register (CPUM).

**Table 2-8-1 Oscillation Stabilization Wait Time**

DLYS1	DLYS0	Oscillation stabilization wait time
0	0	$2^{14}$ x System clock
0	1	$2^{10}$ x System clock
1	0	$2^6$ x System clock
1	1	$2^2$ x System clock





## 3-1 Overview

This LSI speeds up interrupt response with circuitry that automatically loads the branch address to the corresponding interrupt service routine from an interrupt vector table : reset, non-maskable interrupts (NMI), 16 maskable peripheral interrupts, and 6 external interrupts.

For interrupts other than reset, the interrupt processing sequence consists of interrupt request, interrupt acceptance, and hardware processing. After the interrupt is accepted, the program counter (PC) and processor status word (PSW) and handy addressing data (HA) are saved onto the stack. And an interrupts handler ends by restoring, using the POP instruction and other means, the contents of any registers used during processing and then executing the return from interrupt (RTI) instruction to return to the point at which execution was interrupted. Max.12 machine cycles before execution, and max 11 machine cycles after execution.

Each interrupt has an interrupt control register, which controls the interrupts. Interrupt control register consists of the interrupt level field (LV1-0), interrupt enable flag (IE), and interrupt request flag (IR).

Interrupt request flag (IR) is set to "1" by an interrupt request, and cleared to "0" by the interrupt acceptance. This flag is managed by hardware, but can be rewritten by software.

Interrupt enable flag (IE) is the flag that enables interrupts in the group. There is no interrupt enable flag in non-maskable interrupt (NMI). Once this interrupt request flag is set, it is accepted without any conditions. Interrupt enable flag is set in maskable interrupt. Interrupt enable flag (IE) of each maskable interrupt is valid when the maskable interrupt enable flag (MIE flag) of PSW is "1".

Maskable interrupts have had vector numbers by hardware, but their priority can be changed by setting interrupts level field. There are three hierarchical interrupt levels. If multiple interrupts have the same priority, the one with the lowest vector number takes priority. Maskable interrupts are accepted when its level is higher than the interrupt mask level (IM1-0) of PSW. Non-maskable interrupts are always accepted, regardless of the interrupt mask level.



### 3-1-1 Functions

**Table 3-1-1 Interrupt Functions**

Interrupt type	Reset (interrupt)	Non-maskable interrupt	Maskable interrupt
Vector number	0	1	2 to 28
Table address	x'04000'	x'04004'	x'04008' to x'04070'
Starting address	Address specified by vector address		
Interrupt level	-	-	Level 0 to 2 (set by software)
Interrupt factor	External RST pin input	Errors detection, PI interrupt	External pin input Internal peripheral function
Generated operation	Direct input to CPU core	Input to CPU core from non-maskable interrupt control register (NMICR)	Input interrupt request level set in interrupt level flag (xxxL Vn) of maskable interrupt control register (xxxICR) to CPU core.
Accept operation	Always accepts	Always accepts	Acceptance only by the interrupt control of the register (xxxICR) and the interrupt mask level in PSW.
Machine cycles until acceptance	12	12	12
PSW status after acceptance	All flags are cleared to "0".	The interrupt mask level flag in PSW is cleared to "00".	Values of the interrupt level flag (xxxLVn) are set to the interrupt mask level (masking all interrupt requests with the same or the lower priority).

### 3-1-2 Block Diagram

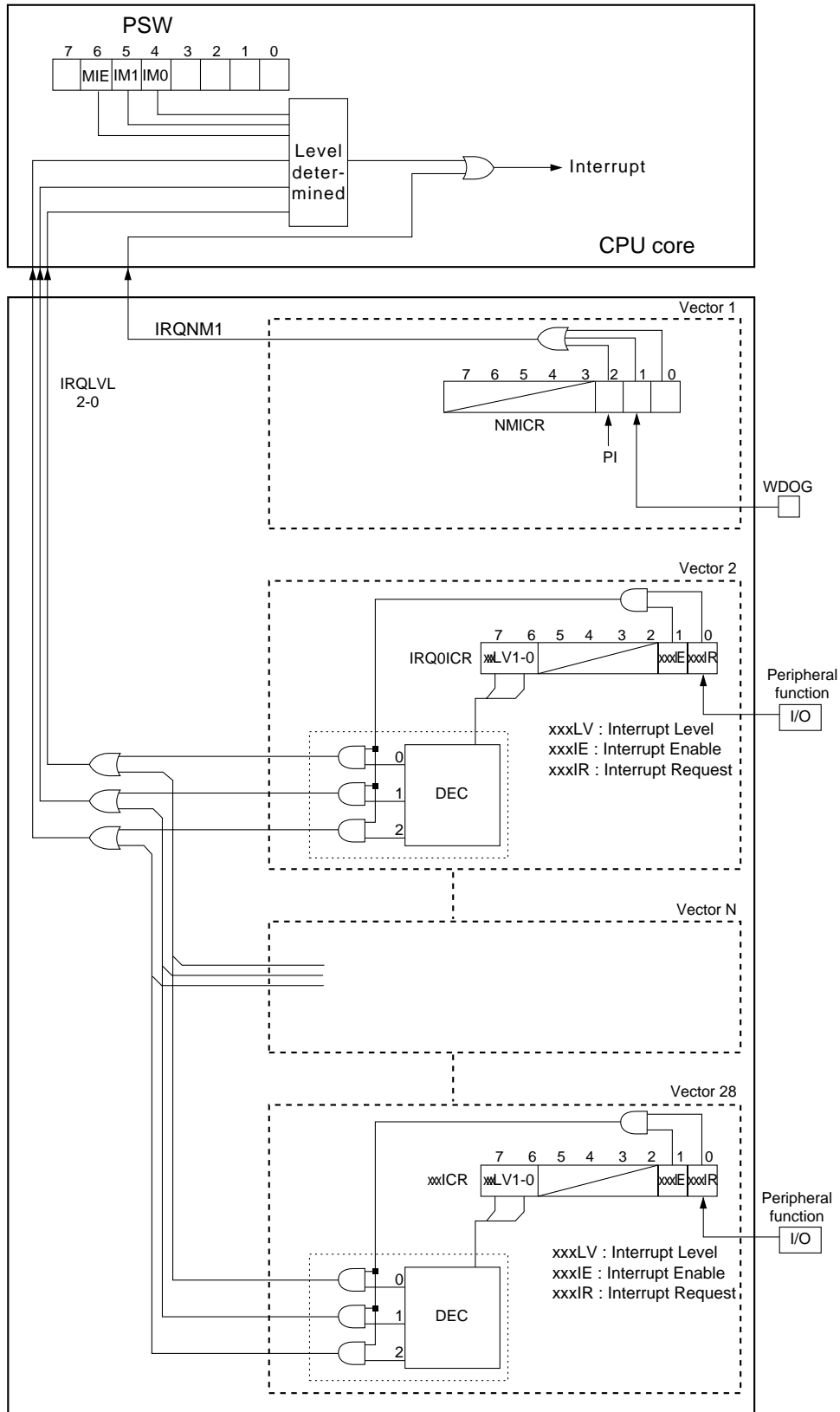


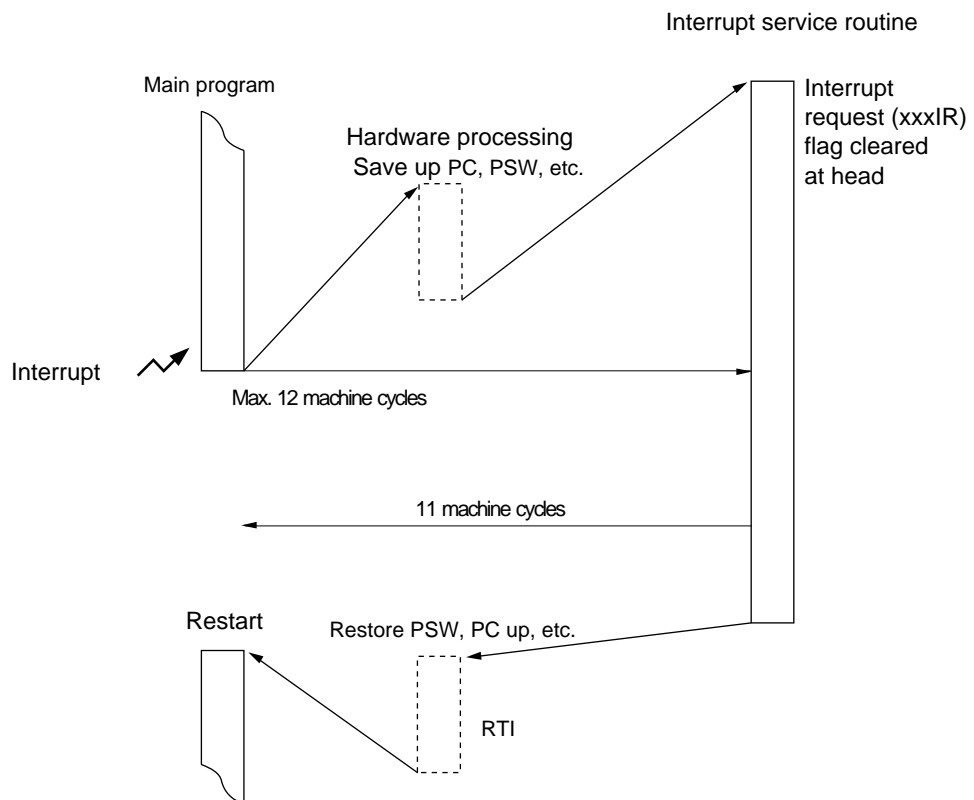
Figure 3-1-1 Interrupt Block Diagram

### 3-1-3 Operation

#### ■Interrupt Processing Sequence

For interrupts other than reset, the interrupt processing sequence consists of interrupt request, interrupt acceptance, and hardware processing. The program counter (PC) and processor status word (PSW) and handy addressing data (HA) are saved onto the stack, and execution branches to the address specified by the corresponding interrupt vector.

An interrupt handler ends by restoring the contents of any registers used during processing and then executing the return from interrupt (RTI) instruction to return to the point at which execution was interrupted.



**Figure 3-1-2 Interrupt Processing Sequence (maskable interrupts)**

### ■ Interrupt Sources and Vector Addresses

Here is the list of interrupt vector address and interrupt group.

**Table 3-1-2 Interrupt Vector Address and Interrupt Group**

Vector Number	Vector Address	Interrupt group (Interrupt source)		Control Register (address)	
0	x'04000'	Reset	-	-	-
1	x'04004'	Non-maskable interrupt	NMI	NMICR	x'03FE1'
2	x'04008'	External interrupt 0	IRQ0	IRQ0ICR	x'03FE2'
3	x'0400C'	External interrupt 1	IRQ1	IRQ1ICR	x'03FE3'
4	x'04010'	External interrupt 2	IRQ2	IRQ2ICR	x'03FE4'
5	x'04014'	External interrupt 3	IRQ3	IRQ3ICR	x'03FE5'
6	x'04018'	External interrupt 4	IRQ4	IRQ4ICR	x'03FE6'
7	x'0401C'	External interrupt 5	IRQ5	IRQ5ICR	x'03FE7'
8	x'04020'	Reserved	-	-	-
9	x'04024'	Timer 0 interrupt	TM0IRQ	TM0ICR	x'03FE9'
10	x'04028'	Timer 1 interrupt	TM1IRQ	TM1ICR	x'03FEA'
11	x'0402C'	Timer 2 interrupt	TM2IRQ	TM2ICR	x'03FEB'
12	x'04030'	Timer 3 interrupt	TM3IRQ	TM3ICR	x'03FEC'
13	x'04034'	Timer 4 interrupt	TM4IRQ	TM4ICR	x'03FED'
14	x'04038'	Reserved	-	-	-
15	x'0403C'	Timer 6 interrupt	TM6IRQ	TM6ICR	x'03FEF'
16	x'04040'	Time base interrupt	TBIRQ	TBICR	x'03FF0'
17	x'04044'	Timer 7 interrupt	TM7IRQ	TM7ICR	x'03FF1'
18	x'04048'	Timer 7 compare2-match	T7OC2IRQ	T7OC2ICR	x'03FF2'
19	x'0404C'	Reserved	-	-	-
20	x'04050'	Reserved	-	-	-
21	x'04054'	Serial interface 0 UART reception interrupt	SC0RIRQ	SC0RICR	x'03FF5'
22	x'04058'	Serial interface 0 interrupt	SC0TIRQ	SC0TICR	x'03FF6'
23	x'0405C'	Serial interface 1 interrupt	SC1IRQ	SC1ICR	x'03FF7'
24	x'04060'	Serial interface 2 interrupt	SC2IRQ	SC2ICR	x'03FF8'
25	x'04064'	Serial interface 3 interrupt	SC3IRQ	SC3ICR	x'03FF9'
26	x'04068'	A/D converter interrupt	ADIRQ	ADICR	x'03FFA'
27	x'0406C'	Reserved	-	-	-
28	x'04070'	ATC1 interrupt	ATC1IRQ	ATC1ICR	x'03FFC'
29	x'04074'	Reserved	-	-	-
30	x'04078'	Reserved	-	-	-



For unused interrupts and reserved interrupts, set the address on which the RTI instruction is described to the corresponded address.

■Interrupt Level and Priority

This LSI allocated vector numbers and interrupt control registers (except reset interrupt) to each interrupt. The interrupt level (except reset interrupt, non-maskable interrupt) can be set by software, per each interrupt group. There are three hierarchical interrupt levels. If multiple interrupts have the same priority, the one with the lowest vector number takes priority. For example, if a vector 3 set to level 1 and a vector 4 set to level 2 request interrupts simultaneously, vector 3 will be accepted.

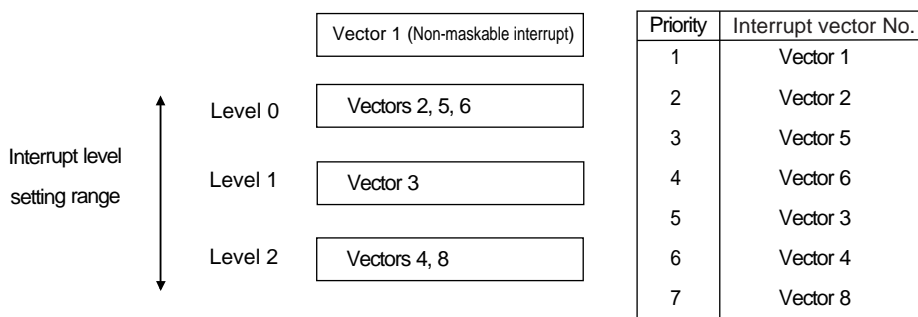

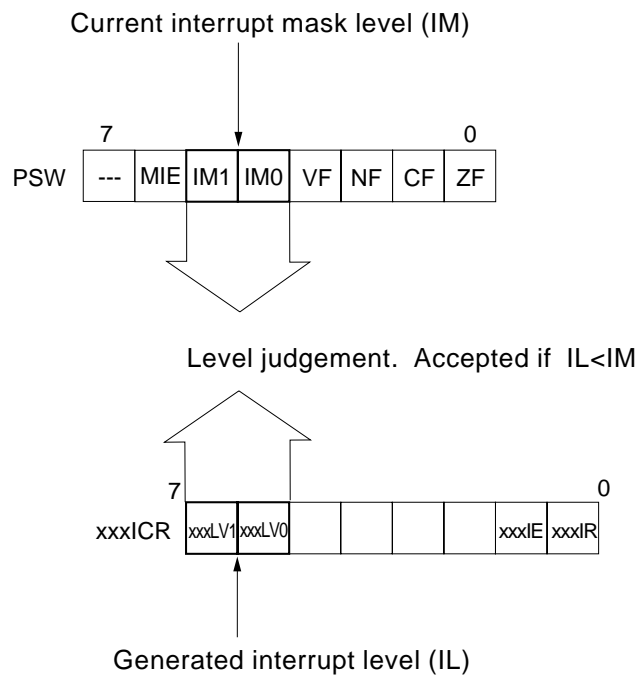


Figure 3-1-3 Interrupt Priority Outline


■ Determination of Interrupt Acceptance


The following is the procedure from interrupt request input to acceptance.

- (1) The interrupt request flag (xxxIR) in the corresponding external interrupt control register (IRQnICR) or internal interrupt control register (xxxICR) is set to '1'.
- (2) An interrupt request is input to the CPU, If the interrupt enable flag (xxxIE) in the same register is '1'.
- (3) The interrupt level (IL) is set for each interrupt. The interrupt level (IL) is input to the CPU.
- (4) The interrupt request is accepted, if IL has higher priority than IM and MIE is '1'  
 [  Chapter 2. 2-1-7 Processor Status Word ]
- (5) After the interrupt is accepted, the hardware resets the interrupt request flag (xxxIR) in the interrupt control register (xxxICR) to '0'.



**Figure 3-1-4 Determination of Interrupt Acceptance**

 The corresponding interrupt enable flag (xxxIE) is not cleared to "0", even if the interrupt is accepted.

 When the setting is as xxxLV=1, XXXLV0=1, the interrupt of that vector is disabled, regardless of the value of xxxIE, xxxIR.

MIE='0' and interrupts are disabled when:

- MIE in the PSW is reset to '0' by a program
- Reset is detected

MIE='1' and interrupts are enabled when:

- MIE in the PSW is set to '1' by a program

The interrupt mask level (IM=IM1 - IM0) in the processor status word (PSW) changes when:

- The program alters it directly,
- A reset initializes it to 0 (00b),
- The hardware accepts and thus switches to the interrupt level (IL) for a maskable interrupt, or
- Execution of the RTI instruction at the end of an interrupt service routine restores the processor status word (PSW) and thus the previous interrupt mask level.



The maskable interrupt enable (MIE) flag in the processor status word (PSW) is not cleared to "0".



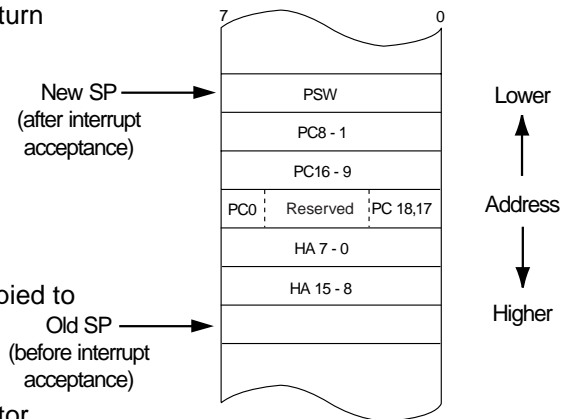
Non-maskable interrupts have priority over maskable ones.

**■Interrupt Acceptance Operation**

When accepting an interrupt, this LSI hardware saves the handy address register, the return address from the program counter, and the processor status word (PSW) to the stack and branches to the interrupt handler using the starting address in the vector table.

The following is the hardware processing sequence after by interrupt acceptance.

1. The stack pointer (SP) is updated.  
(SP-6 → SP)
2. The contents of the handy address register (HA) are saved to the stack.  
Upper half of HA → (SP+5)  
Lower half of HA → (SP+4)
3. The contents of the program counter (PC), the return address, are saved to the stack.  
PC bits 18, 17, and 0 → (SP+3)  
PC bits 16-9 → (SP+2)  
PC bits 8-1 → (SP+1)
4. The contents of the PSW are saved to the stack.  
PSW → (SP)
5. The interrupt level (xxxLVn) for the interrupt is copied to the interrupt mask (IMn) in the PSW.  
Interrupt level (xxxLVn) → IMn
6. The hardware branches to the address in the vector table.



**Figure 3-1-5 Stack Operation during interrupt acceptance**

**■Interrupt Return Operation**

An interrupt handler ends by restoring, using the POP instruction and other means, the contents of any registers used during processing and then executing the return from interrupt (RTI) instruction to return to the point at which execution was interrupted.

The following is the processing sequence after the RTI instruction.

1. The contents of the PSW are restored from the stack. (SP)
2. The contents of the program counter (PC), the return address, are restored from the stack. (SP+1 to SP+3)
3. The contents of the handy address register (HA) are restored from the stack. (SP+4, SP+5)
4. The stack pointer is updated. (SP+6 → SP)
5. Execution branches to the address in the program counter.

The handy address register is an internal register used by the handy addressing function. The hardware saves its contents to the stack to prevent the interrupt from interfering with operation of the function.

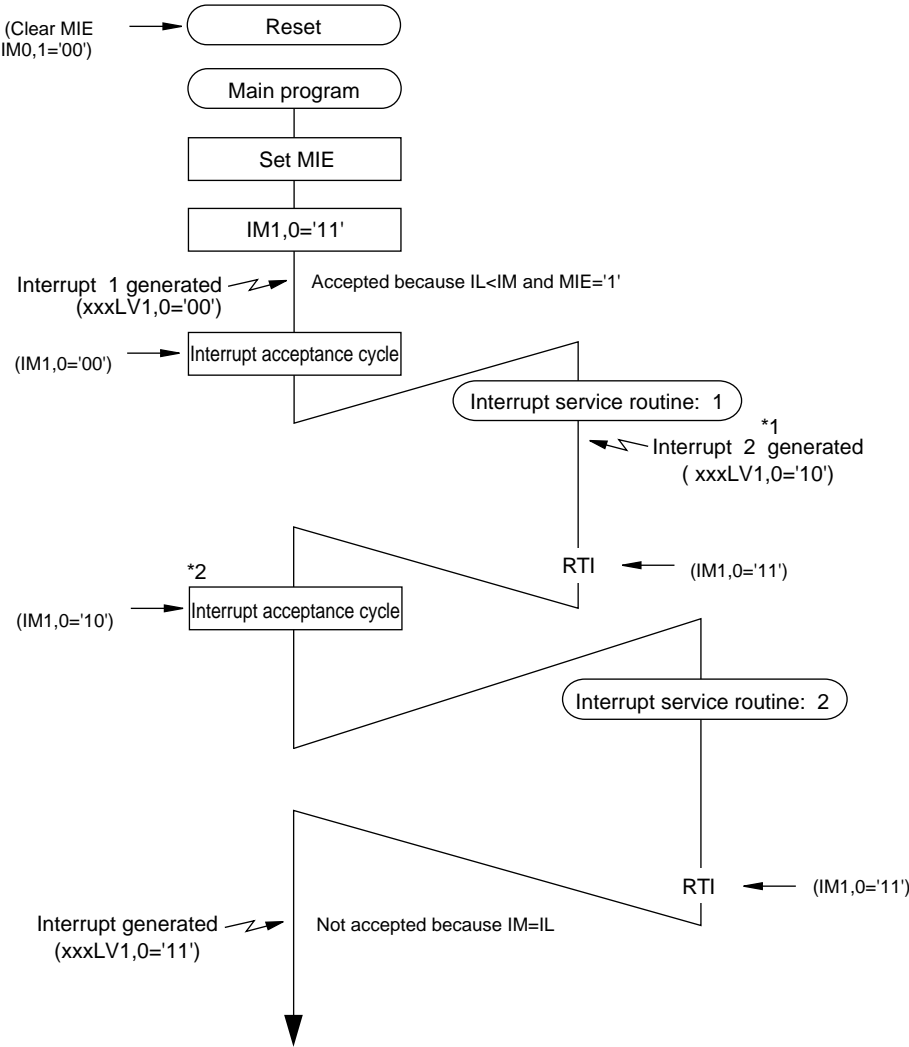
Registers such as data register, or address register are not saved, so that PUSH instruction should be used to save data register or address register onto the stack, if necessary.

The address bp6 to bp2, when program counter (PC) are saved to the stack, are reserved. Do not change by program.



■Maskable Interrupt

Figure 3-1-6 shows the processing flow when a second interrupt with a lower priority level (xxxLV1-xxxLV0='10') arrives during the processing of one with a higher priority level (xxxLV1-xxxLV0='00').



Parentheses ( ) indicate hardware processing.

\*1 If during the processing of the first interrupt, an interrupt request with an interrupt level (IL) numerically lower than the interrupt mask (IM) arrives, it is accepted as a nested interrupt. If  $IL \geq IM$ , however, the interrupt is not accepted.

\*2 The second interrupt, postponed because its interrupt level (IL) was numerically greater than the interrupt mask (IM) for the first interrupt service routine, is accepted when the first interrupt handler returns.

Figure 3-1-6 Processing Sequence for Maskable Interrupts

### ■ Multiplex Interrupt

When an MN101C49K series device accepts an interrupt, it automatically disables acceptance of subsequent interrupts with the same or lower priority level. When the hardware accepts an interrupt, it copies the interrupt level (xxxLVn) for the interrupt to the interrupt mask (IM) in the PSW. As a result, subsequent interrupts with the same or lower priority levels are automatically masked. Only interrupts with higher priority levels are accepted. The net result is that interrupts are normally processed in decreasing order of priority. It is, however, possible to alter this arrangement.

#### 1. To disable interrupt nesting

- Reset the MIE bit in the PSW to "0."
- Raise the priority level of the interrupt mask (IM) in the PSW.

#### 2. To enable interrupts with lower priority than the currently accepted interrupt

- Lower the priority level of the interrupt mask (IM) in the PSW.



Multiplex interrupts are only enabled for interrupts with levels higher than the PSW interrupt mask level (IM).

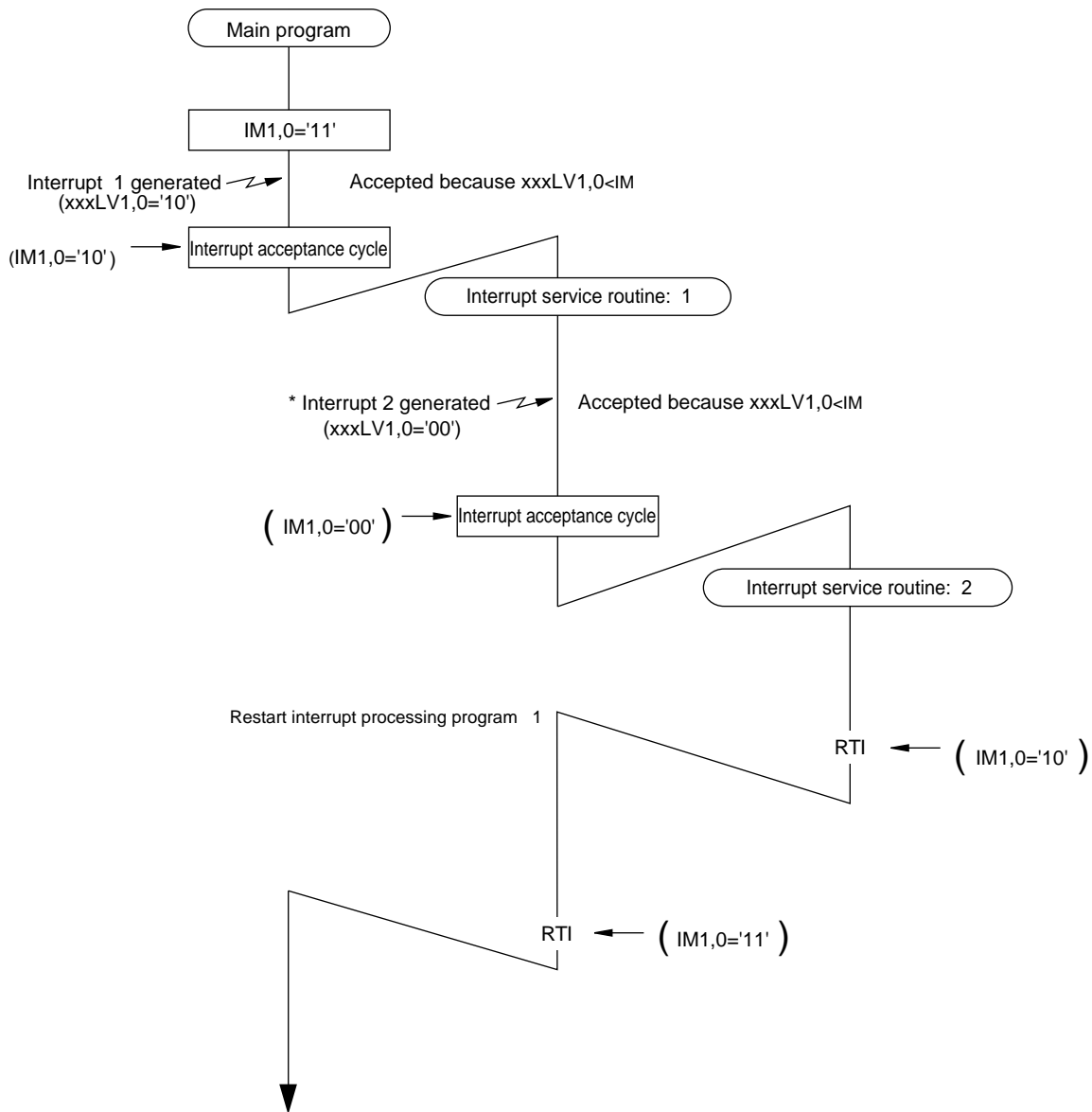


It is possible to forcibly rewrite IM to accept an interrupt with a priority lower than the interrupt being processed, but be careful of stack overflow.



Do not operate the maskable interrupt control register (xxxICR) when multiple interrupts are enabled. If operation is necessary, first clear the PSW MIE flag to disable interrupts.

Figure 3-1-7 shows the processing flow for multiple interrupts (interrupt 1: xxxLV1-xxxLV0='10', and interrupt 2: xxxLV1-xxxLV0='00').



Parentheses ( ) indicate hardware processing

Figure 3-1-7 Processing Sequence with Multiple Interrupts Enabled

### 3-1-4 Interrupt Flag Setup

#### ■ Interrupt request flag (IR) setup by the software

The interrupt request flag is operated by the hardware. That is set to "1" when any interrupt factor is generated, and cleared to "0" when the interrupt is accepted. If you want to operate it by the software, the IRWE flag of MEMCTR should be set to "1".

#### ■ Interrupt flag setup procedure

A setup procedure of the interrupt request flag set by the hardware and the software shows as follows ;

Setup Procedure	Description
(1) Disable all maskable interrupts. PSW bp6 : MIE = 0	(1) Clear the MIE flag of PSW to disable all maskable interrupts. This is necessary, especially when the interrupt control register is changed.
(2) Select the interrupt factor.	(2) Select the interrupt factor such as interrupt edge selection, or timer interrupt cycle change.
(3) Enable the interrupt request flag to be rewritten. MEMCTR (x'3F01') bp2 : IRWE = 1	(3) Set the IRWE flag of MEMCTR to enable the interrupt request flag to be rewritten. This is necessary only when the interrupt request flag is changed by the software.
(4) Rewrite the interrupt request flag. xxxICR bp0 : xxxIR	(4) Rewrite the interrupt request flag (xxxIR) of the interrupt control register (xxxICR).
(5) Disable the interrupt request flag to be rewritten. MEMCTR (x'3F01') bp2 : IRWE = 0	(5) Clear the IRWE flag so that interrupt request flag can not be rewritten by the software.
(6) Set the interrupt level. xxxICR bp7-6 : xxxLV1-0 PSW bp5-4 : IM1-0	(6) Set the interrupt level by the xxxLV1-0 flag of the interrupt control register (xxxICR). Set the IM1-0 flag of PSW when the interrupt acceptance level of CPU should be changed.
(7) Enable the interrupt. xxxICR bp1 : xxxIE = 1	(7) Set the xxxIE flag of the interrupt control register (xxxICR) to enable the interrupt.
(8) Enable all maskable interrupts. PSW bp6 : MIE = 1	(8) Set the MIE flag of PSW to enable maskable interrupts.

## 3-2 Control Registers

### 3-2-1 Registers List

**Table 3-2-1 Interrupt Control Registers**

Register	Address	R/W	Functions	Page
NMICR	x'03FE1'	R/W	Non-maskable interrupt control register	III - 16
IRQ0ICR	x'03FE2'	R/W	External interrupt 0 control register	III - 18
IRQ1ICR	x'03FE3'	R/W	External interrupt 1 control register	III - 19
IRQ2ICR	x'03FE4'	R/W	External interrupt 2 control register	III - 20
IRQ3ICR	x'03FE5'	R/W	External interrupt 3 control register	III - 21
IRQ4ICR	x'03FE6'	R/W	External interrupt 4 control register	III - 22
IRQ5ICR	x'03FE7'	R/W	External interrupt 5 control register	III - 23
TM0ICR	x'03FE9'	R/W	Timer 0 interrupt control register (Timer 0 interrupt)	III - 24
TM1ICR	x'03FEA'	R/W	Timer 1 interrupt control register (Timer 1 interrupt)	III - 25
TM2ICR	x'03FEB'	R/W	Timer 2 interrupt control register (Timer 2 interrupt)	III - 26
TM3ICR	x'03FEC'	R/W	Timer 3 interrupt control register (Timer 3 interrupt)	III - 27
TM4ICR	x'03FED'	R/W	Timer 4 interrupt control register (Timer 4 interrupt)	III - 28
TM6ICR	x'03FEF'	R/W	Timer 6 interrupt control register (Timer 6 interrupt)	III - 29
TBICR	x'03FF0'	R/W	Time base interrupt control register (Time base period)	III - 30
TM7ICR	x'03FF1'	R/W	Timer 7 interrupt control register (Timer 7 interrupt)	III - 31
T7OC2ICR	x'03FF2'	R/W	Timer 7 compare register2-match interrupt control register	III - 32
SC0RICR	x'03FF5'	R/W	Serial interface 0 UART reception interrupt control register (Serial interface 0 UART reception interrupt)	III - 33
SC0TICR	x'03FF6'	R/W	Serial interface 0 interrupt control register (Serial interface 0 interrupt)	III - 34
SC1ICR	x'03FF7'	R/W	Serial interface 1 interrupt control register (Serial interface 1 interrupt)	III - 35
SC2ICR	x'03FF8'	R/W	Serial interface 2 interrupt control register (Serial interface 2 interrupt)	III - 36
SC3ICR	x'03FF9'	R/W	Serial interface 3 interrupt control register (Serial interface 3 interrupt)	III - 37
ADICR	x'03FFA'	R/W	A/D conversion interrupt control register (A/D converter interrupt)	III - 38
ATC1ICR	x'03FFC'	R/W	ATC1 interrupt control register(ATC interrupt)	III - 39



Writing to the interrupt control register should be done after that all maskable interrupts are set to be disabled by the MIE flag of the PSW register.



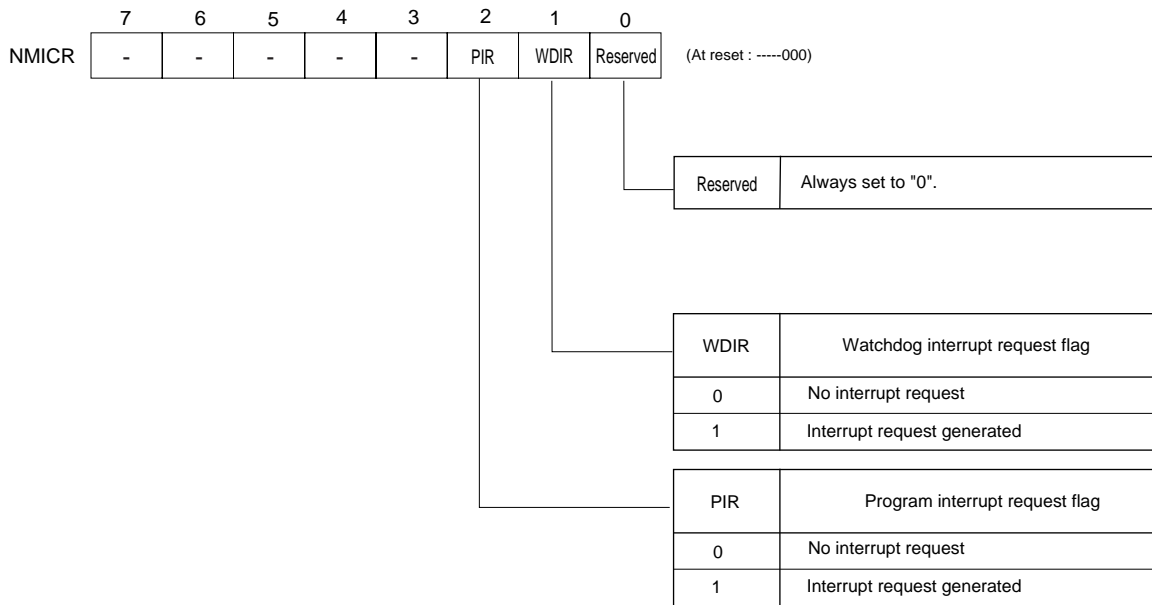
If the interrupt level flag (xxxLVn) is set to "level 3", its vector is disabled, regardless of interrupt enable flag and interrupt request flag.

### 3-2-2 Interrupt Control Registers

The interrupt control registers include the maskable interrupt control registers (xxxICR) and the non-maskable interrupt control register (NMICR).

■ Non-Maskable Interrupt Control Register (NMICR address: x'03FE1')

The non-maskable interrupt control register (NMICR) stores the non maskable interrupt request. When the non-maskable interrupt request is generated, the interrupt is accepted regardless of the interrupt mask level (IMn) of PSW. The hardware then branches to the address stored at location x'04004' in the interrupt vector table. The watchdog timer overflow interrupt request flag (WDIR) is set to "1" when the watchdog timer overflows. The program interrupt request flag (PIR) is set to "1" when the undefined instruction is executed.



**Figure 3-2-1 Non-Maskable Interrupt Control Register (NMICR:x'03FE1', R/W)**

On this LSI, when undefined instruction is decoded, the program interrupt request flag (PIR) is set to "1", and the non-maskable interrupt is generated. If the PIR flag setup is confirmed by the non-maskable interrupt service routine, the reset via the software is recommended. When software reset, the reset pin (p27) outputs "0".

Once the WDIR flag becomes "1" after non-maskable interrupt happens, only the program can clear it to "0".



Faulty interrupt that does not occur under normal conditions could be occurred with certain combinations of instruction codes. In programming, please follow the instructions shown below.

Faulty interrupt could be occurred independently of issue of a branch instruction if the instruction code right after the one of the following 19 branch instructions in a program is "2FD", "3DA", or "3DB", which is identical to relevant unspecified instructions.

The relevant 19 branch instructions are ; BEQ, BNE, BGE, BCC, BCS, BLT, BLE, BGT, BHI, BLS, BNC, BNS, BVC, BVS, BRA, CBEQ, CBNE, TBZ, TBNZ.

This faulty interrupt halts the ICE operation with "Illegal instruction break", and also causes a non-maskable interrupt on Mask ROM, EEPROM and Flash ROM products.

The cause is a design error in the hardware circuits.

Example :

When a branch instruction is placed right in front of a ROM data and if the instruction right behind a branch instruction (code "89") is "2FD", above faulty interrupt is occurred.

Addr	Code	Nmonic	
04100	AA	mov (A0),D0	
04100	89D7	bra +7D	) The instruction code (ROM data) right behind the branch instruction (code "89") is "2FD"
04102	2F	dc F2	
04103	D0	dc 0D	

We are providing a software diagnostic tool.

Please refer to the documents attached to the diagnostic tool for how to use it

If above problem is identified with the diagnostic tool, insert a "nop" instruction to avoid the above relevant condition to be fulfilled.

Example :

Addr	Code	Nmonic	
04100	AA	mov (A0),D0	
04100	89F7	bra +7F	If above problem is identified with the diagnostic tool, insert a "nop" instruction to avoid the above relevant condition to be fulfilled.
04102	00	nop	
04103	2F	dc F2	
04104	D0	dc 0D	

The diagnostic tool can be downloaded from our Web site of TECHNICAL REPORT.

■ External Interrupt 0 Control Register (IRQ0ICR)

The external interrupt 0 control register (IRQ0ICR) controls interrupt level of the external interrupt 0, active edge, interrupt enable and interrupt request. Interrupt control register should be operated when the maskable interrupt enable flag (MIE) of PSW is "0".

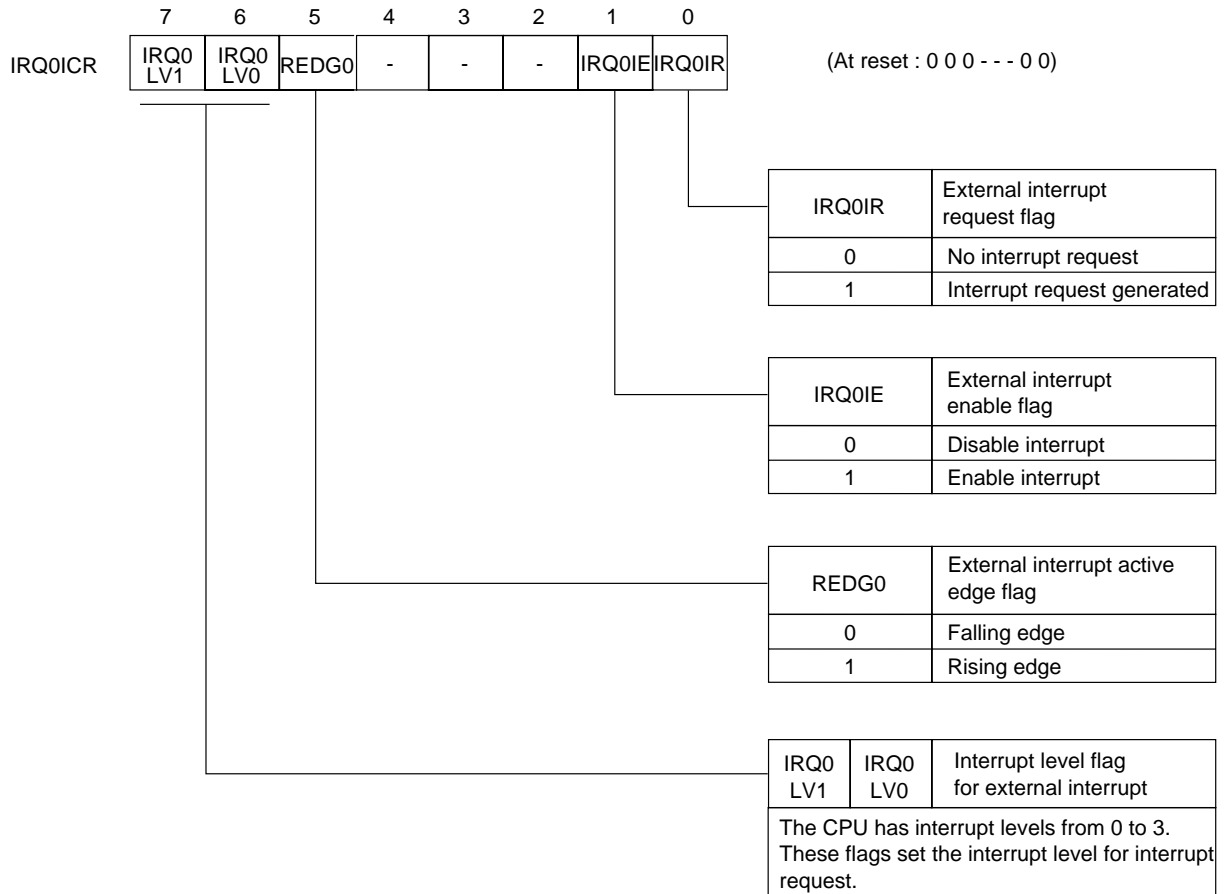


Figure 3-2-2 External Interrupt 0 Control Register (IRQ0ICR : x'03FE2', R/W)



■External Interrupt 1 Control Register (IRQ1ICR)

The external interrupt 1 control register (IRQ1ICR) controls interrupt level of external interrupt 1, active edge, interrupt enable and interrupt request. Interrupt control register should be operated when the maskable interrupt enable flag (MIE) of PSW is "0".

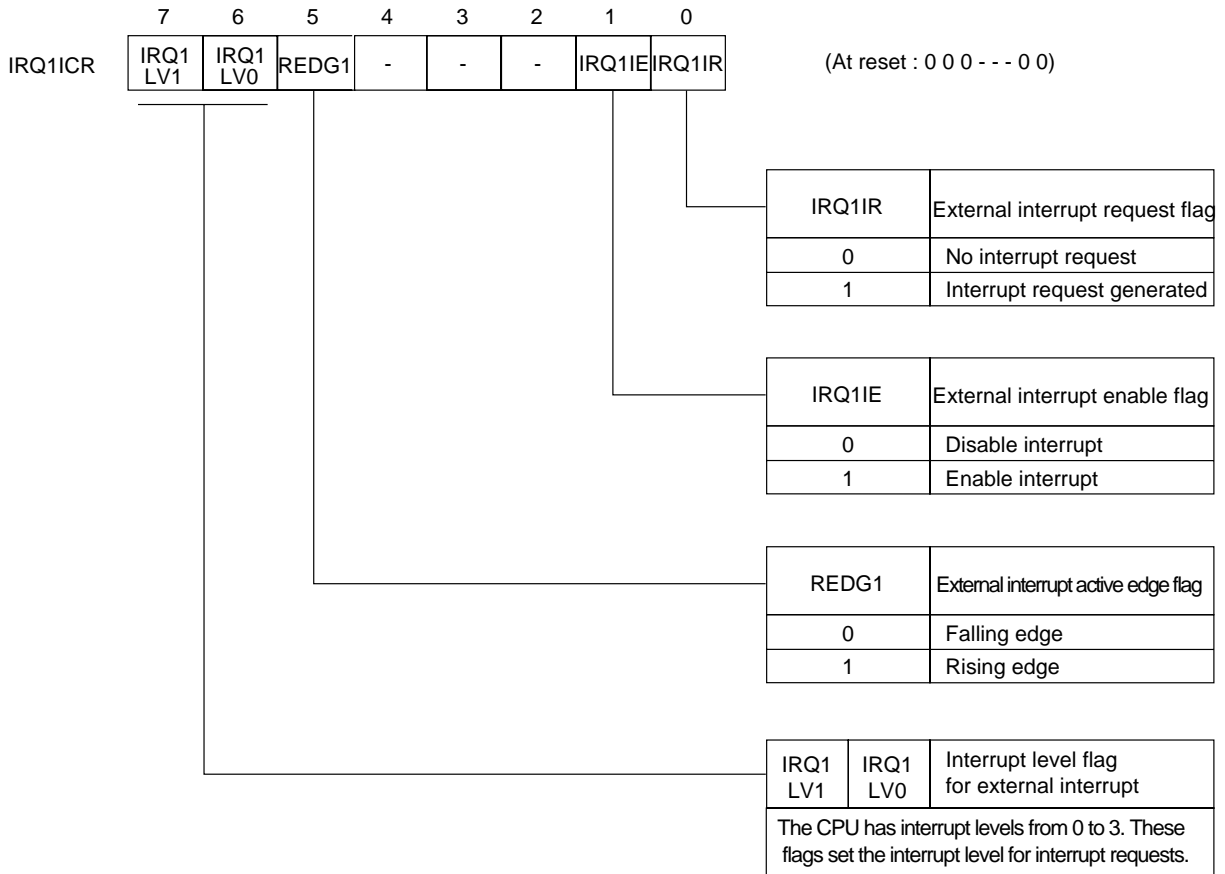


Figure 3-2-3 External Interrupt 1 Control Register (IRQ1ICR : x'03FE3', R/W)

■ External Interrupt 2 Control Register (IRQ2ICR)

The external interrupt 2 control register (IRQ2ICR) controls interrupt level of external interrupt 2, active edge, interrupt enable and interrupt request. Interrupt control register should be operated when the maskable interrupt enable flag (MIE) of PSW is "0".

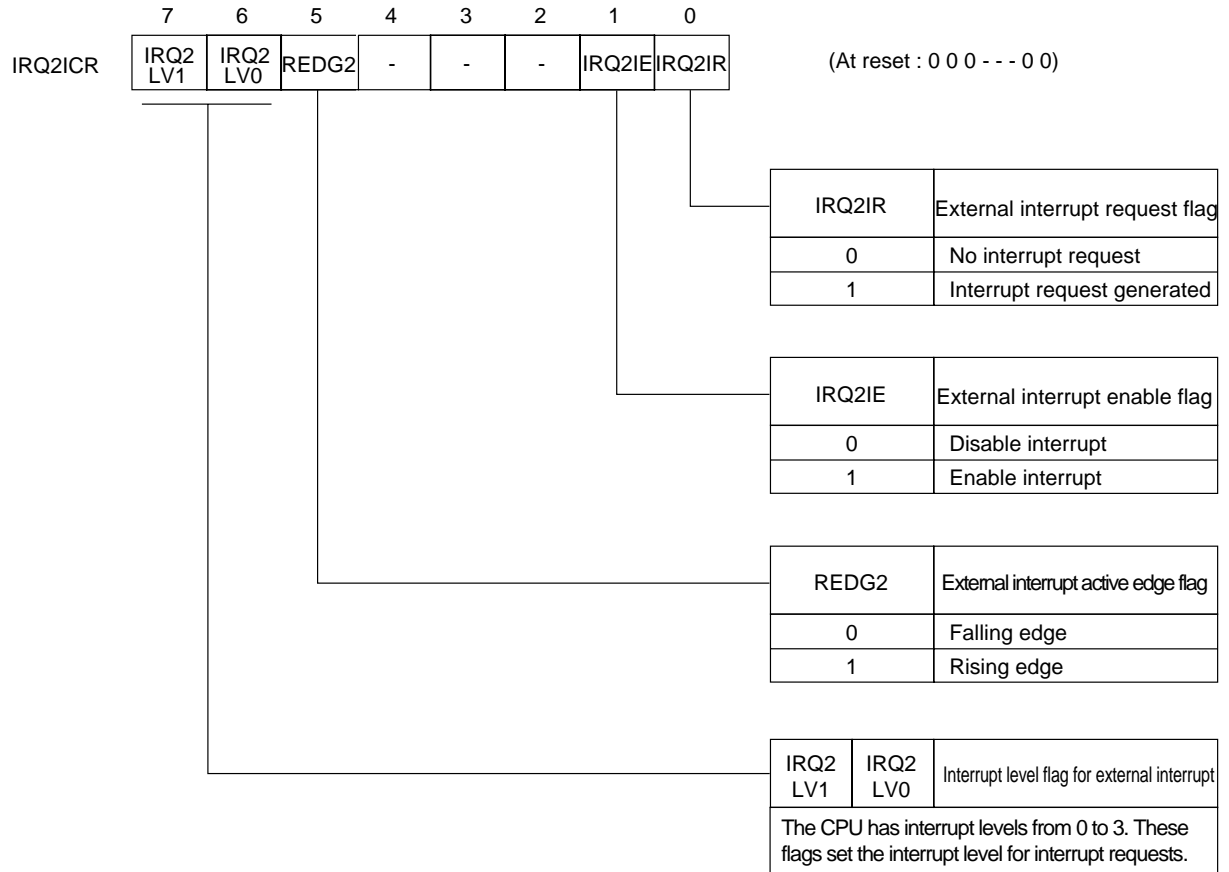


Figure 3-2-4 External Interrupt 2 Control Register (IRQ2ICR : x'03FE4', R/W)

■ External Interrupt 3 Control Register (IRQ3ICR)

The external interrupt 3 control register (IRQ3ICR) controls interrupt level of external interrupt 3, active edge, interrupt enable flag and interrupt request. Interrupt control register should be operated when the maskable interrupt enable flag (MIE) of PSW is "0".

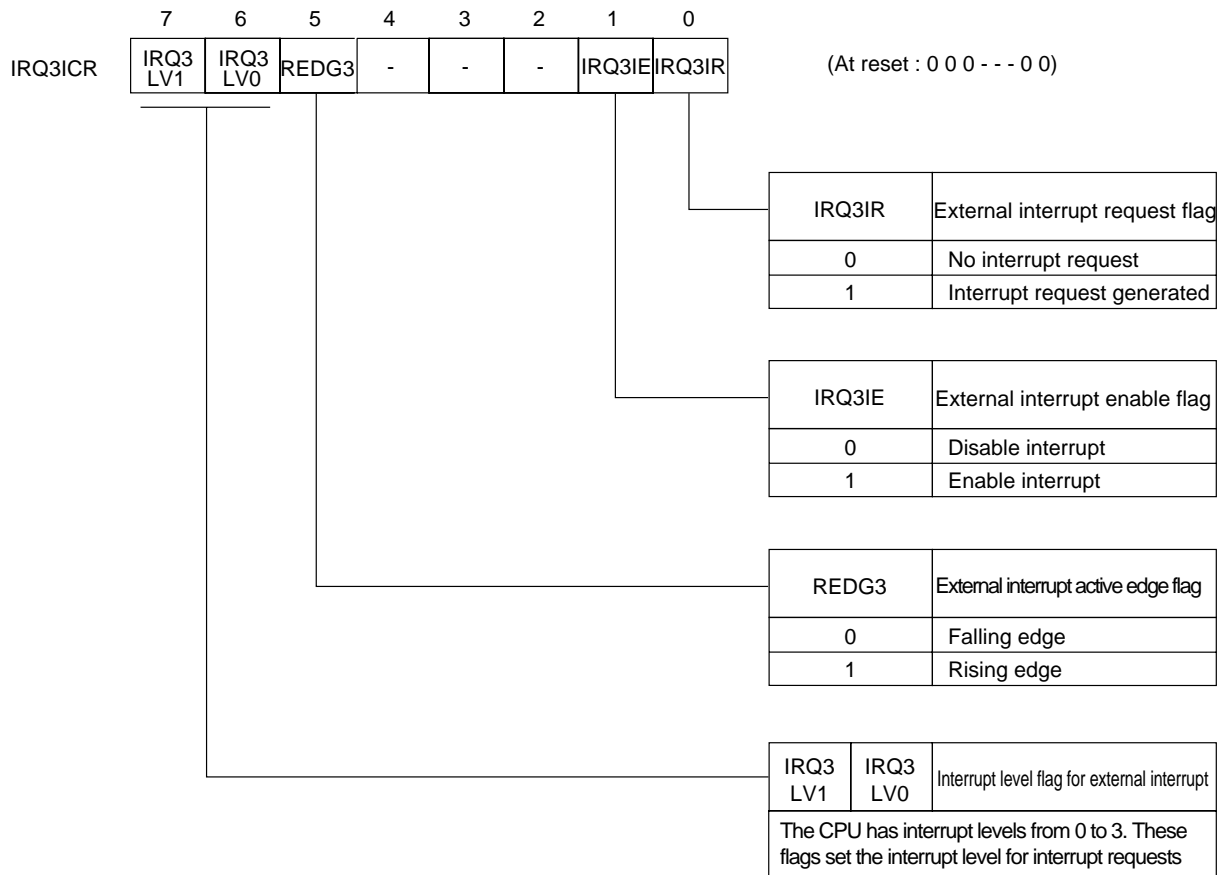


Figure 3-2-5 External Interrupt 3 Control Register (IRQ3ICR : x'03FE5', R/W)

■ External Interrupt 4 Control Register (IRQ4ICR)

The external interrupt 4 control register (IRQ4ICR) controls interrupt level of external interrupt 4, active edge, interrupt enable flag and interrupt request. Interrupt control register should be operated when the maskable interrupt enable flag (MIE) of PSW is "0".

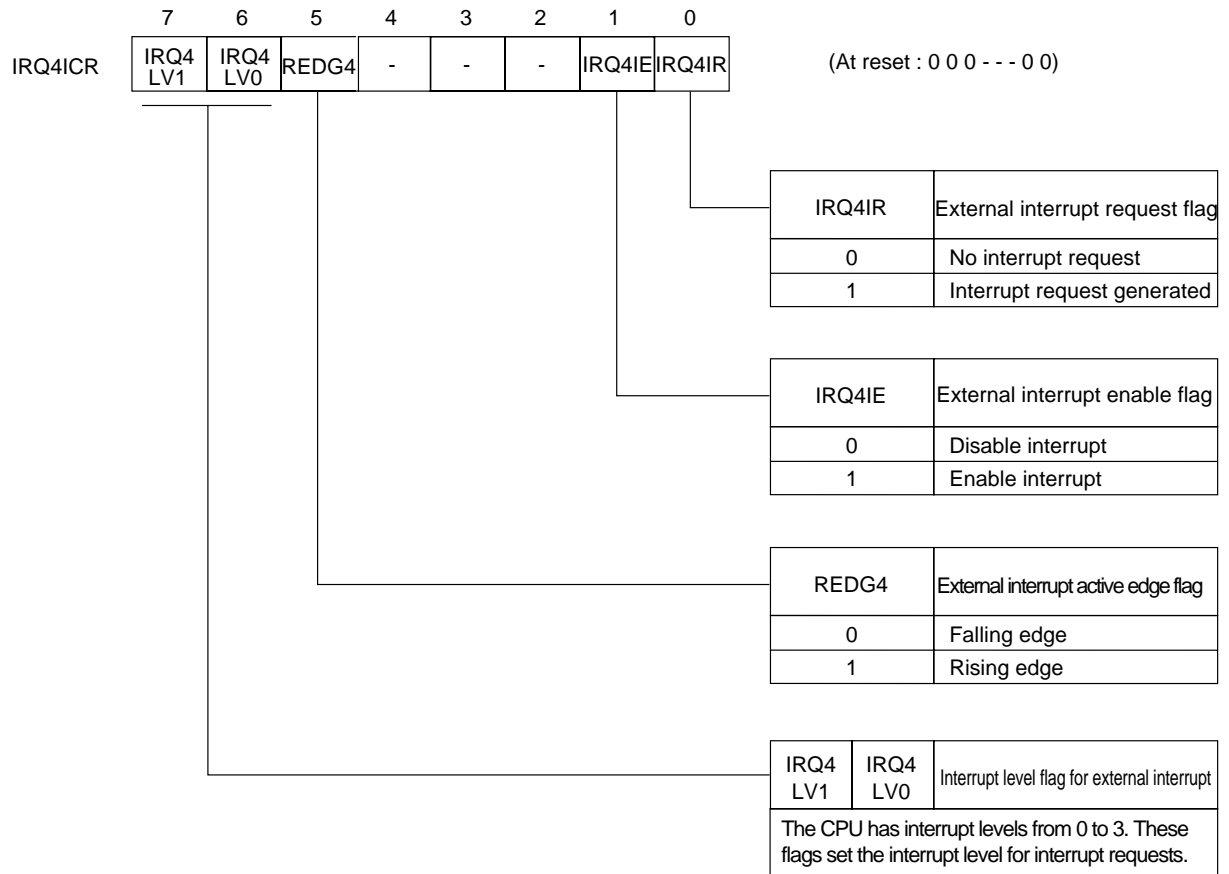


Figure 3-2-6 External Interrupt 4 Control Register (IRQ4ICR : x'03FE6', R/W)

■ External Interrupt 5 Control Register (IRQ5ICR)

The external interrupt 5 control register (IRQ5ICR) controls interrupt level of external interrupt 5, active edge, interrupt enable flag and interrupt request. Interrupt control register should be operated when the maskable interrupt enable flag (MIE) of PSW is "0".

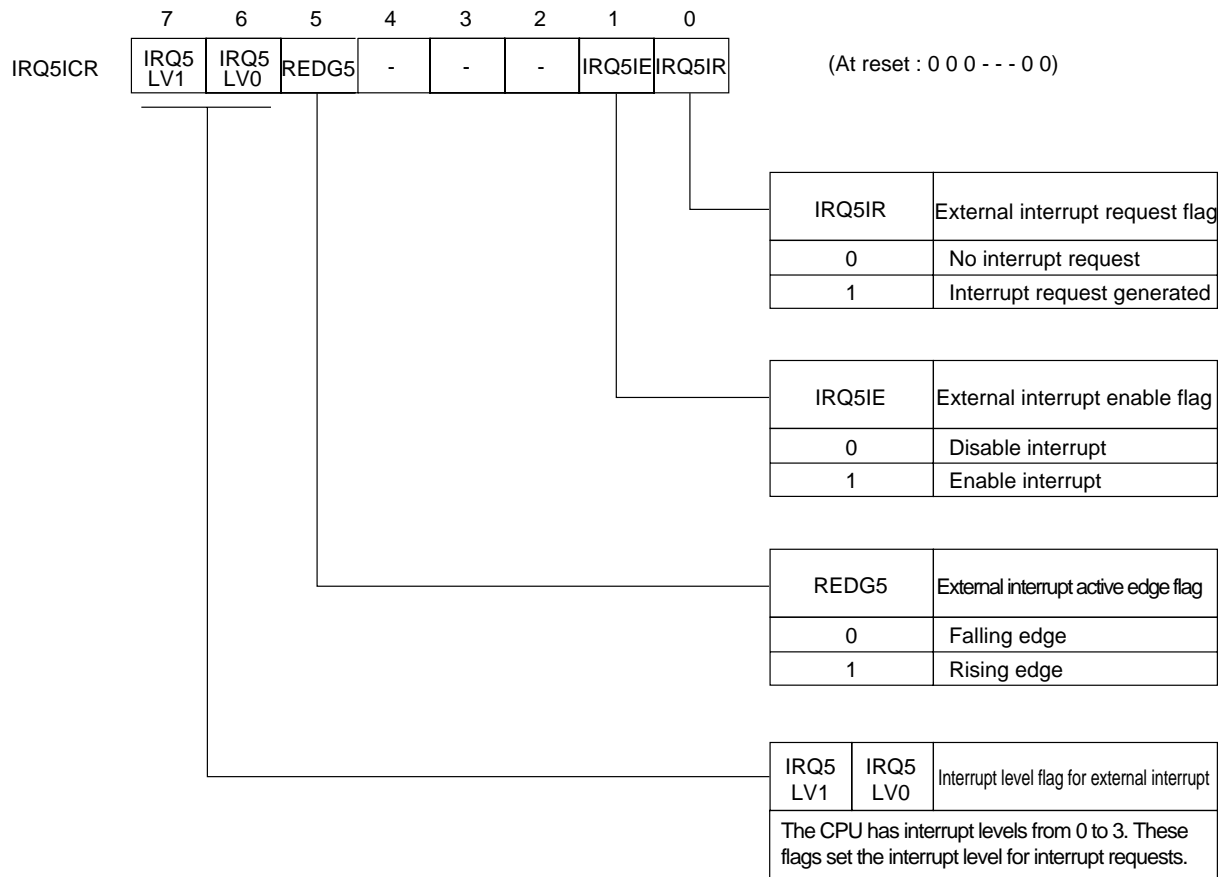


Figure 3-2-7 External Interrupt 5 Control Register (IRQ5ICR : x'03FE7', R/W)

■Timer 0 Interrupt Control Register (TM0ICR)

The timer 0 interrupt control register (TM0ICR) controls interrupt level of timer 0 interrupt, interrupt enable flag and interrupt request. Interrupt control register should be operated when the maskable interrupt enable flag (MIE) of PSW is "0".

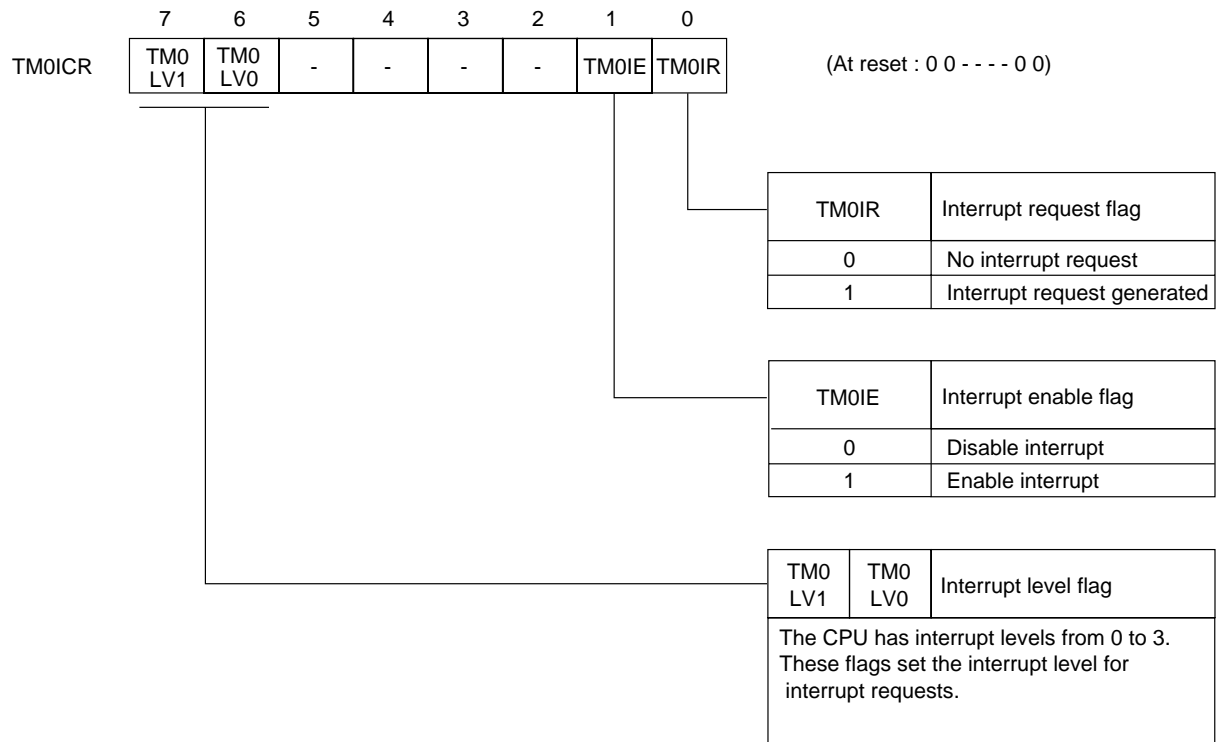


Figure 3-2-8 Timer 0 Interrupt Control Register (TM0ICR : x'03FE9', R/W)

■Timer 1 Interrupt Control Register (TM1ICR)

The timer 1 interrupt control register (TM1ICR) controls interrupt level of timer 1 interrupt, interrupt enable flag and interrupt request. Interrupt control register should be operated when the maskable interrupt enable flag (MIE) of PSW is "0".

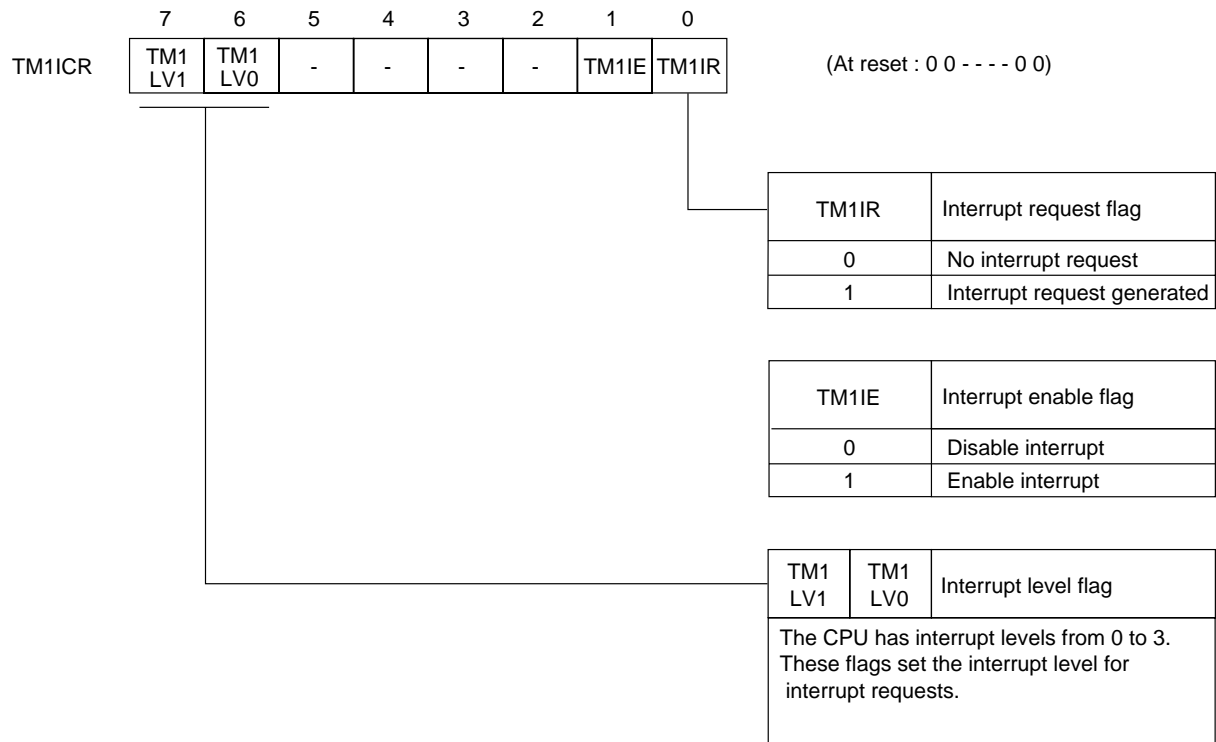


Figure 3-2-9 Timer 1 Interrupt Control Register (TM1ICR : x'03FEA', R/W)

■Timer 2 Interrupt Control Register (TM2ICR)

The timer 2 interrupt control register (TM2ICR) controls interrupt level of timer 2 interrupt, interrupt enable flag and interrupt request. Interrupt control register should be operated when the maskable interrupt enable flag (MIE) of PSW is "0".

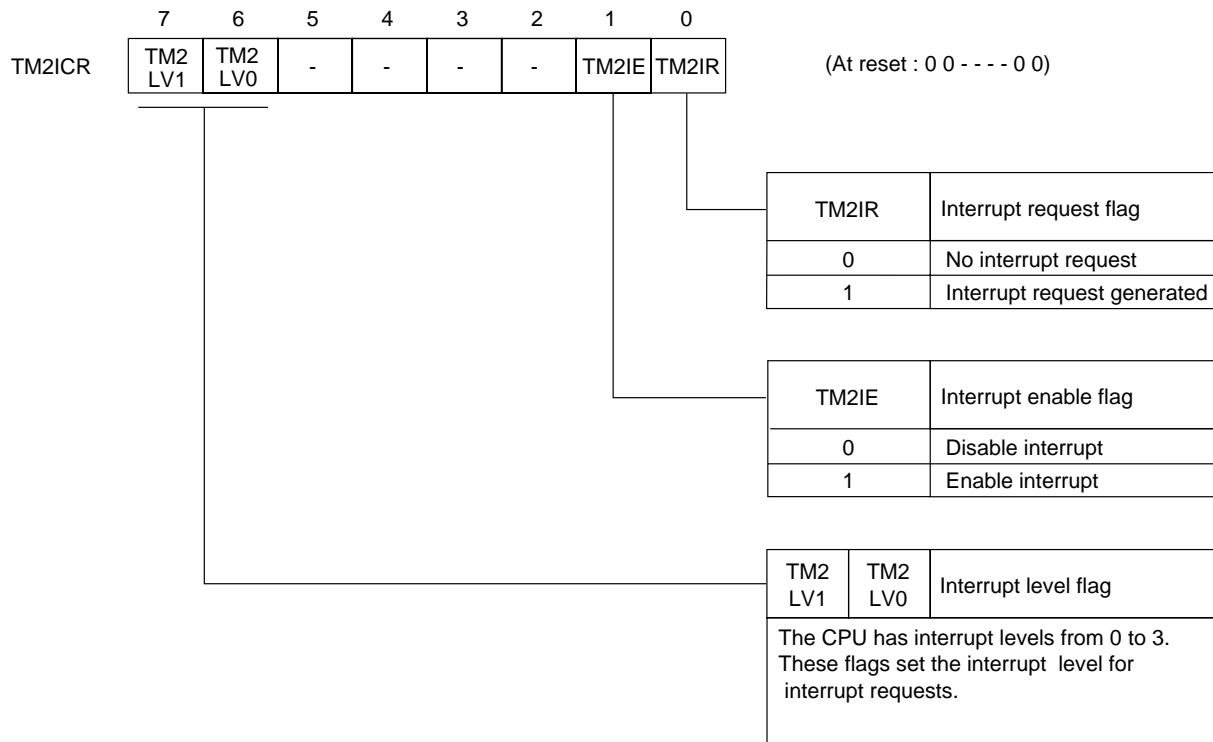


Figure 3-2-10 Timer 2 Interrupt Control Register (TM2ICR : x'03FEB', R/W)



■Timer 3 Interrupt Control Register (TM3ICR)

The timer 3 interrupt control register (TM3ICR) controls interrupt level of timer 3 interrupt, interrupt enable flag and interrupt request. Interrupt control register should be operated when the maskable interrupt enable flag (MIE) of PSW is "0".

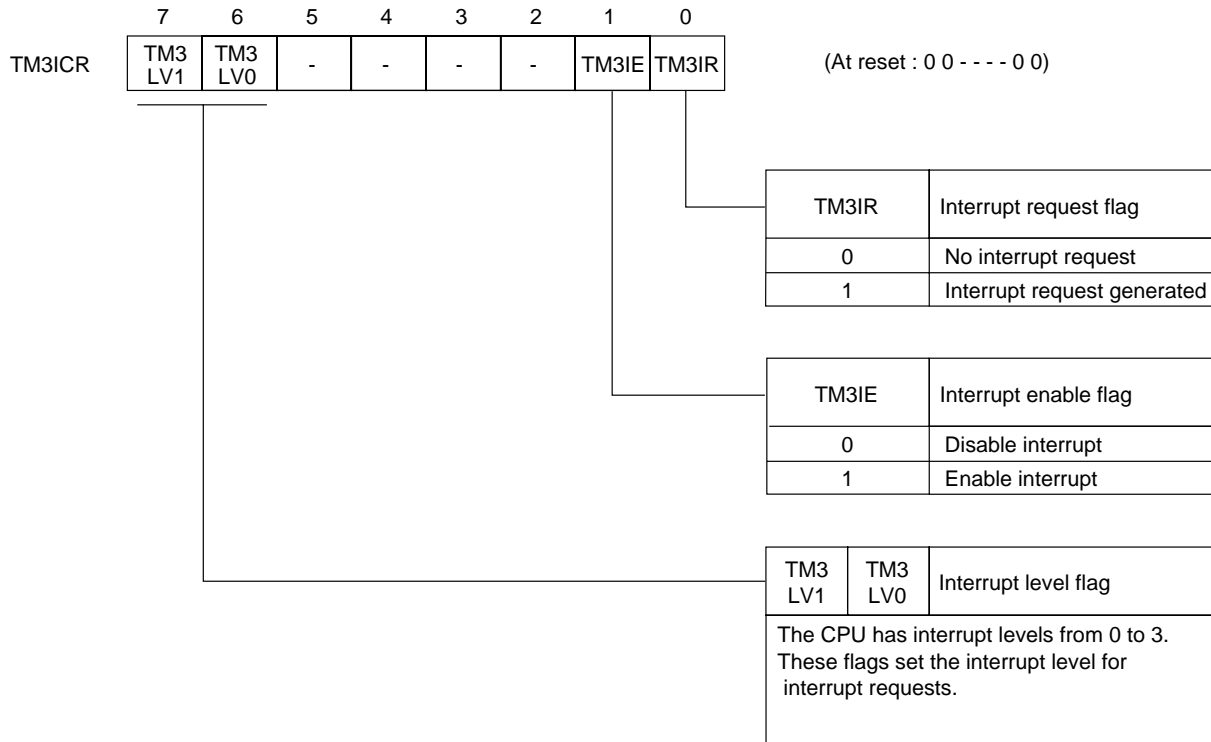


Figure 3-2-11 Timer 3 Interrupt Control Register (TM3ICR : x'03FEC', R/W)

■Timer 4 Interrupt Control Register (TM4ICR)

The timer 4 interrupt control register (TM4ICR) controls interrupt level of timer 4 interrupt, interrupt enable flag and interrupt request. Interrupt control register should be operated when the maskable interrupt enable flag (MIE) of PSW is "0".

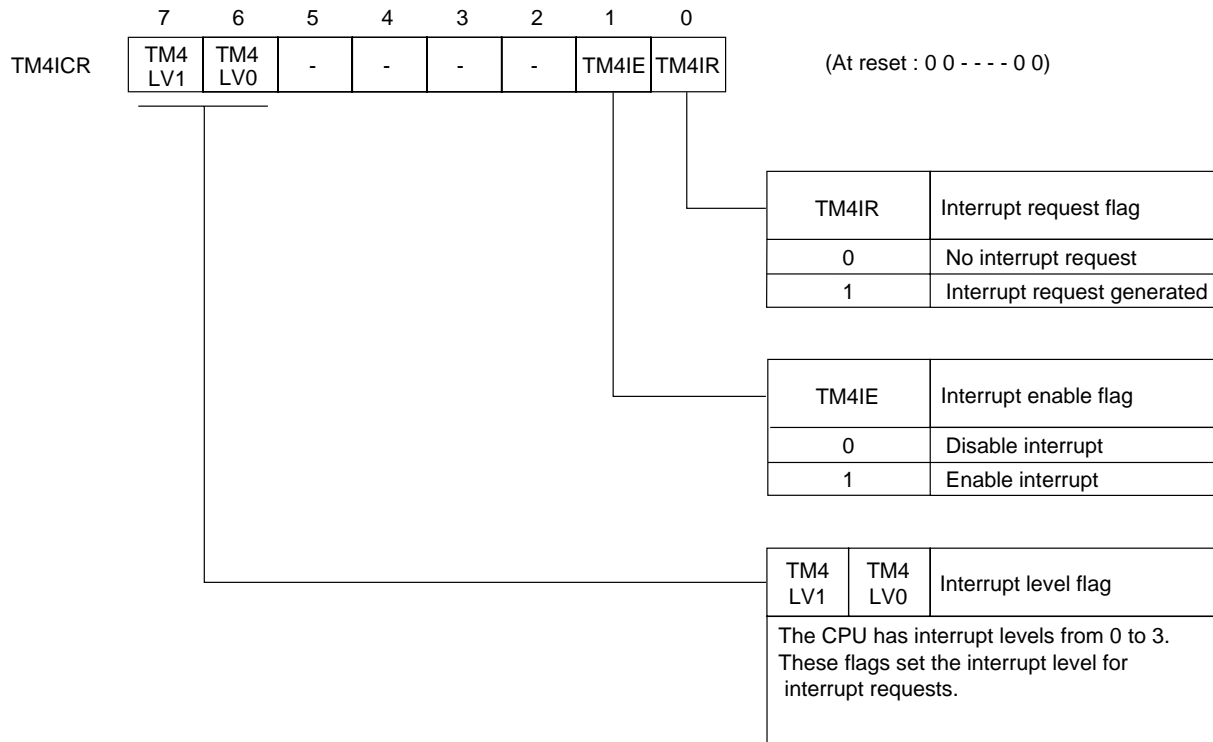


Figure 3-2-12 Timer 4 Interrupt Control Register (TM4ICR : x'03FED', R/W)

■Timer 6 Interrupt Control Register (TM6ICR)

The timer 6 interrupt control register (TM6ICR) controls interrupt level of timer 6 interrupt, interrupt enable flag and interrupt request. Interrupt control register should be operated when the maskable interrupt enable flag (MIE) of PSW is "0".

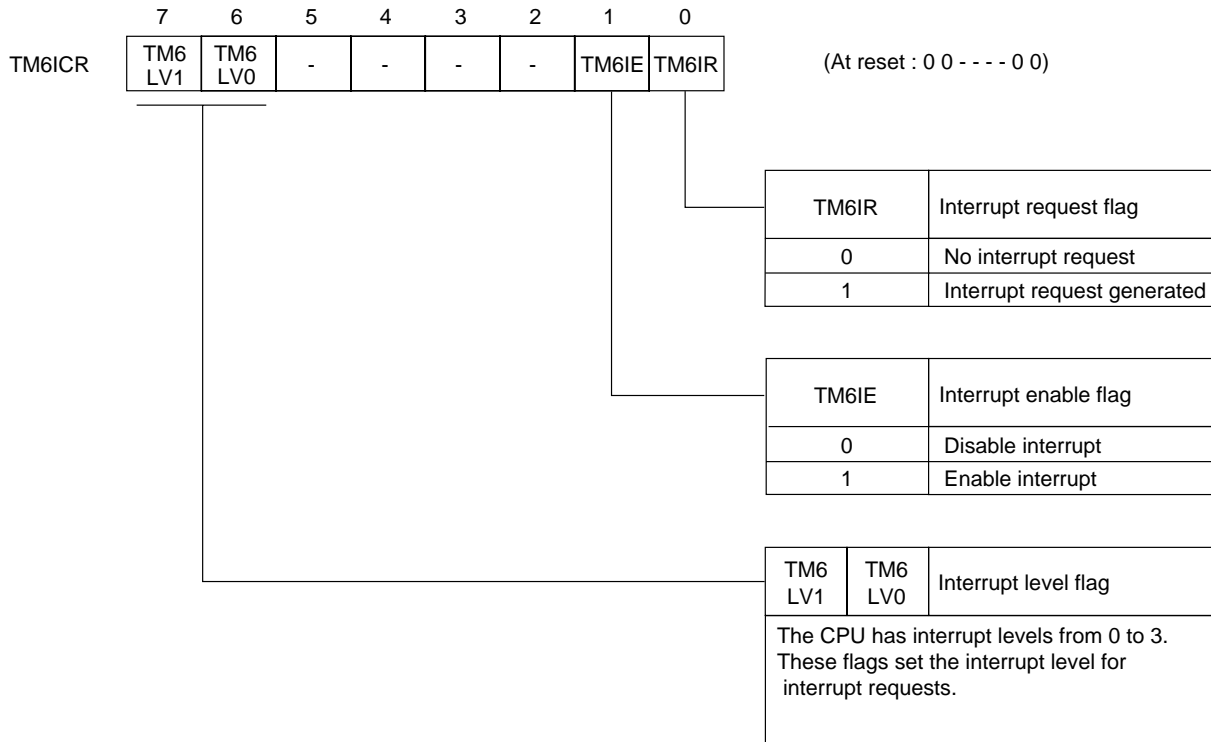


Figure 3-2-13 Timer 6 Interrupt Control Register (TM6ICR : x'03FEF', R/W)

■Time Base Interrupt Control Register (TBICR)

The time base interrupt control register (TBICR) controls interrupt level of time base interrupt, interrupt enable flag and interrupt request. Interrupt control register should be operated when the maskable interrupt enable flag (MIE) of PSW is "0".

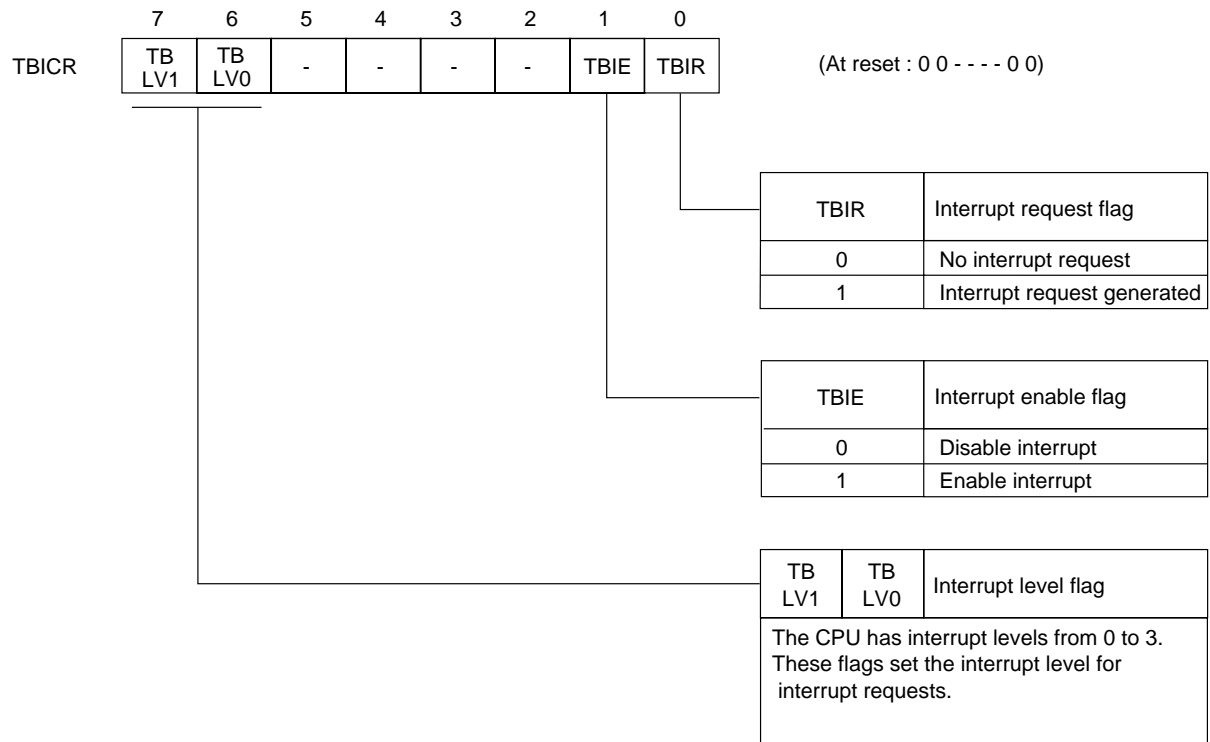


Figure 3-2-14 Time Base Interrupt Control Register (TBICR : x'03FF0', R/W)

■Timer 7 Interrupt Control Register (TM7ICR)

The timer 7 interrupt control register (TM7ICR) controls interrupt level of timer 7 interrupt, interrupt enable flag and interrupt request. Interrupt control register should be operated when the maskable interrupt enable flag (MIE) of PSW is "0".

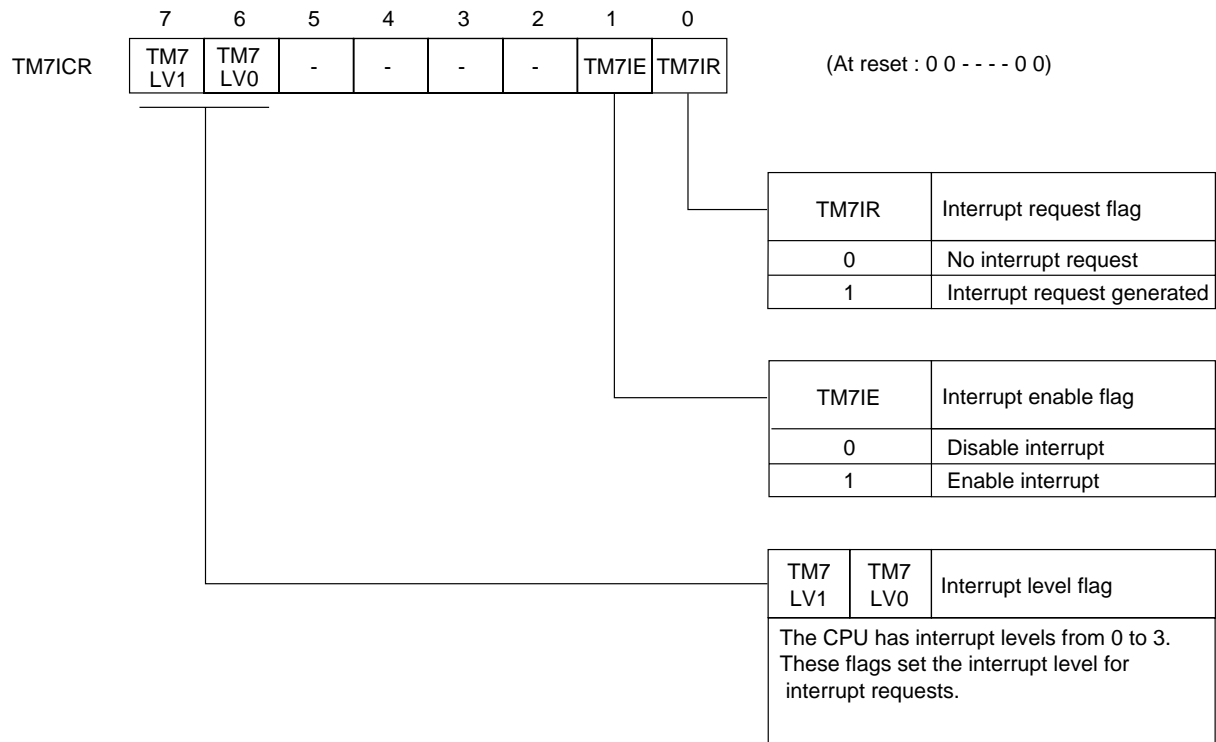
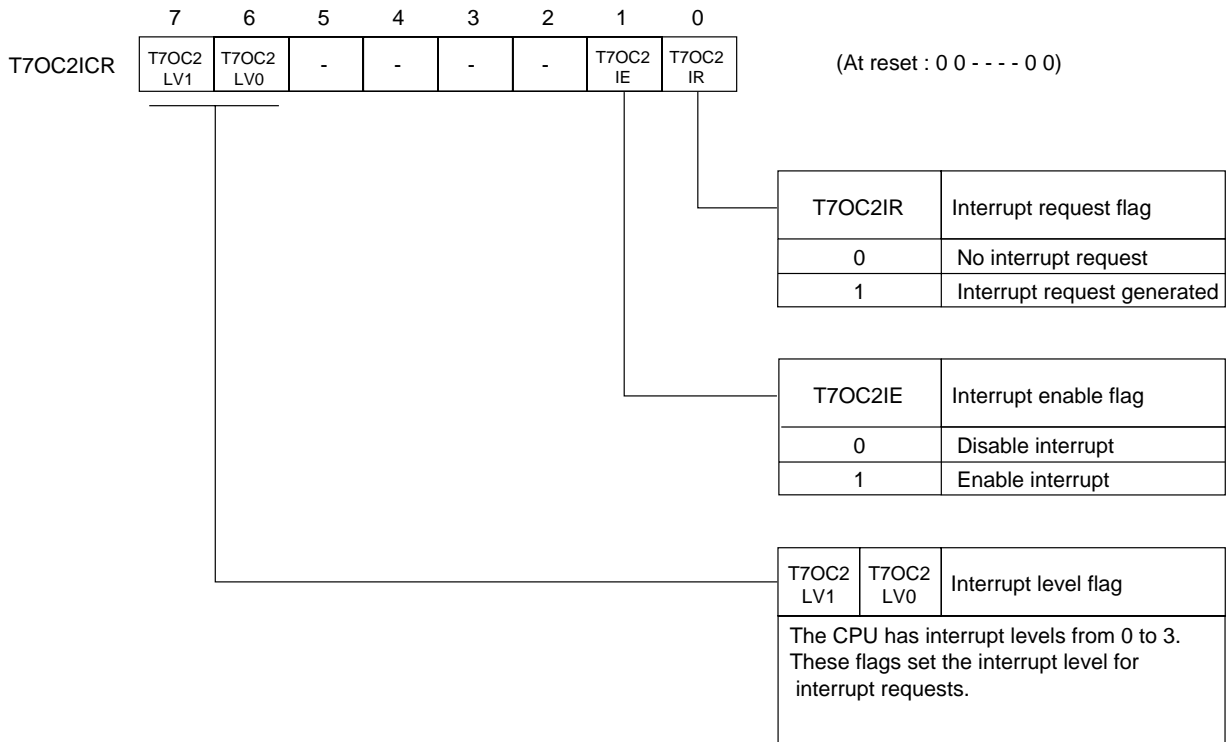


Figure 3-2-15 Timer 7 Interrupt Control Register (TM7ICR : x'03FF1', R/W)

■Timer 7 Compare Register 2-match Interrupt Control Register (TOC2ICR)

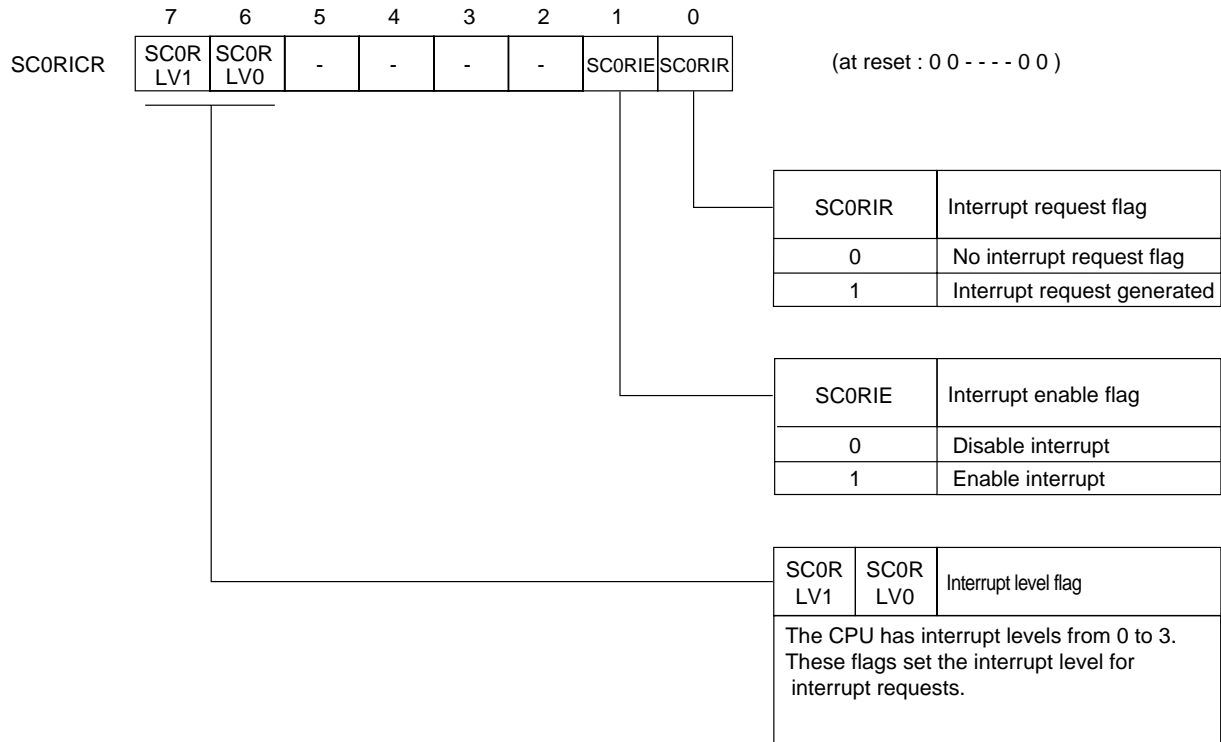
The timer 7 compare register 2-match interrupt control register (TOC2ICR) controls interrupt level of timer 7 compare register 2-match interrupt , interrupt enable flag and interrupt request. Interrupt control register should be operated when the maskable interrupt enable flag (MIE) of PSW is "0".



**Figure 3-2-16 Timer 7 Compare Register 2-match Interrupt Control Register (TMO C2ICR : x'03FF2', R/W)**

■Serial Interface 0 UART Interrupt Control Register (SC0RICR)

The serial Interface 0 UART reception interrupt control register (SC0RICR) controls interrupt level of serial Interface 0 UART reception interrupt, interrupt enable flag and interrupt request. Interrupt control register should be operated when the maskable interrupt enable flag (MIE) of PSW is "0".



**Figure 3-2-17 Serial Interface 0 UART Reception Interrupt Control register (SC0RICR:x'03FF5', R/W)**

■Serial Interface 0 Interrupt Control Register (SC0TICR)

The serial Interface 0 interrupt control register (SC0TICR) controls interrupt level of serial linterface 0 interrupt, interrupt enable flag and interrupt request. Interrupt control register should be operated when the maskable interrupt enable flag (MIE) of PSW is "0".

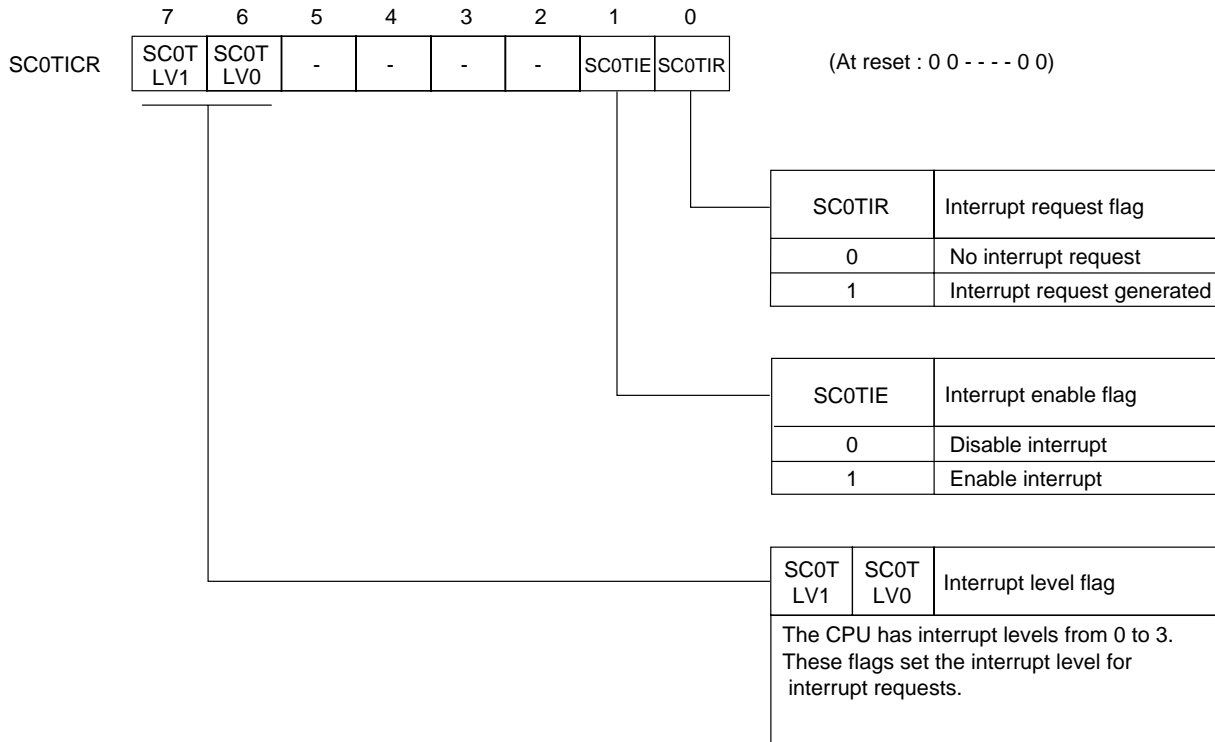


Figure 3-2-18 Serial Interface 0 Interrupt Control Register (SC0TICR : x'03FF6', R/W)



■Serial Interface 1 Interrupt Control Register (SC1ICR)

The serial Interface 1 interrupt control register (SC1ICR) controls interrupt level of serial Interface 1 interrupt, interrupt enable flag and interrupt request. Interrupt control register should be operated when the maskable interrupt enable flag (MIE) of PSW is "0".

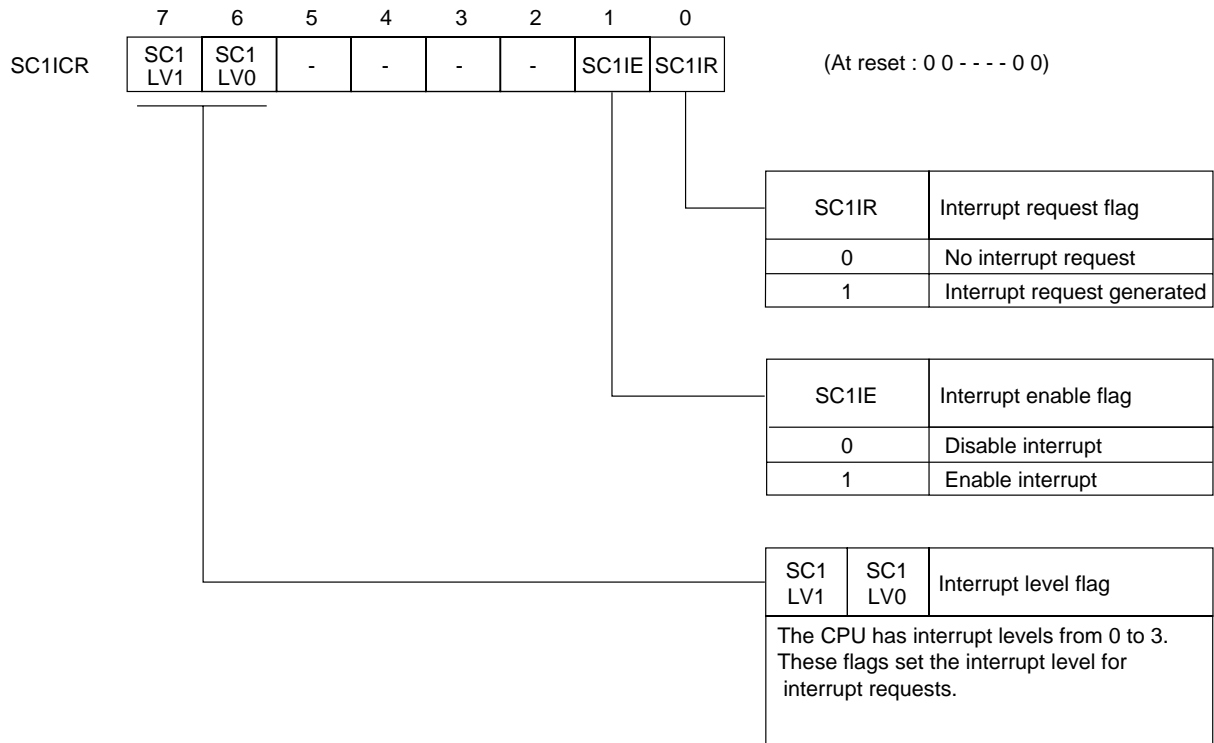


Figure 3-2-19 Serial Interface 1 Interrupt Control Register (SC1ICR : x'03FF7', R/W)

■Serial Interface 2 Interrupt Control Register (SC2ICR)

The serial Interface 2 interrupt control register (SC2ICR) controls interrupt level of serial Interface 2 interrupt, interrupt enable flag and interrupt request. Interrupt control register should be operated when the maskable interrupt enable flag (MIE) of PSW is "0".

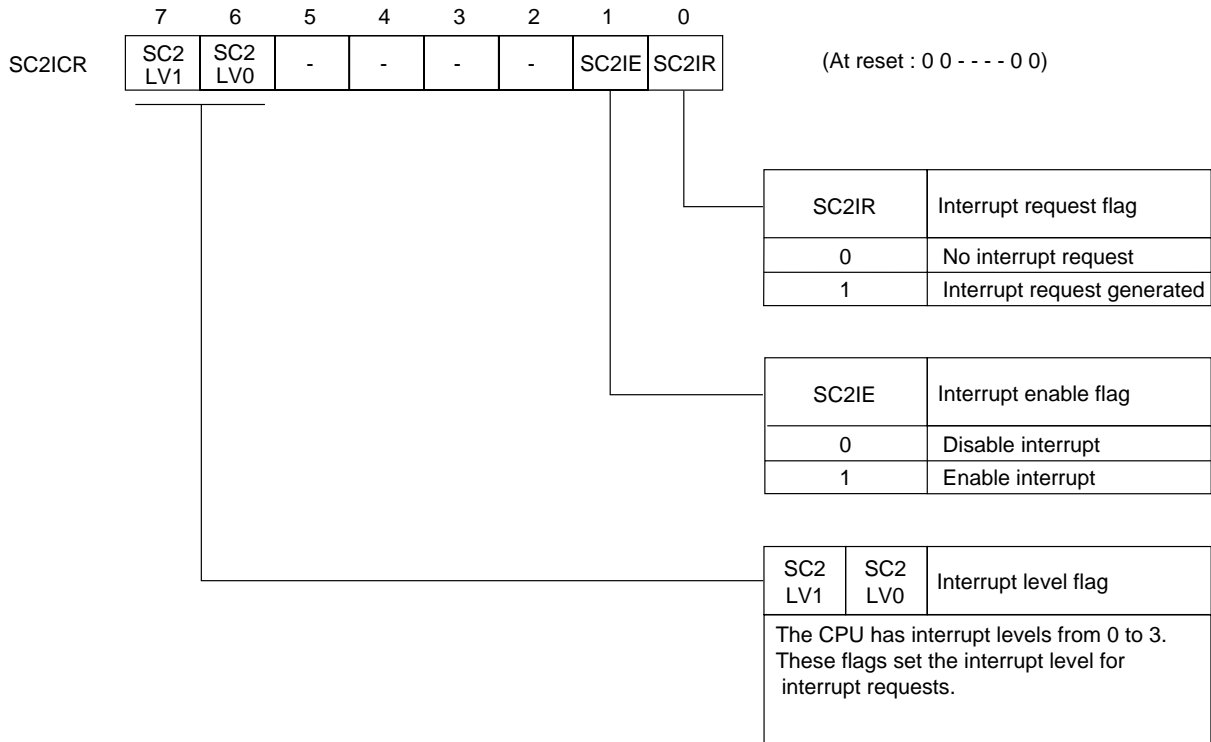


Figure 3-2-20 Serial Interface 2 Interrupt Control Register (SC2ICR : x'03FF8', R/W)

■Serial Interface 3 Interrupt Control Register (SC3ICR)

The serial interface 3 interrupt control register (SC3ICR) controls interrupt level of serial interface 3 interrupt, interrupt enable flag and interrupt request. Interrupt control register should be operated when the maskable interrupt enable flag (MIE) of PSW is "0".

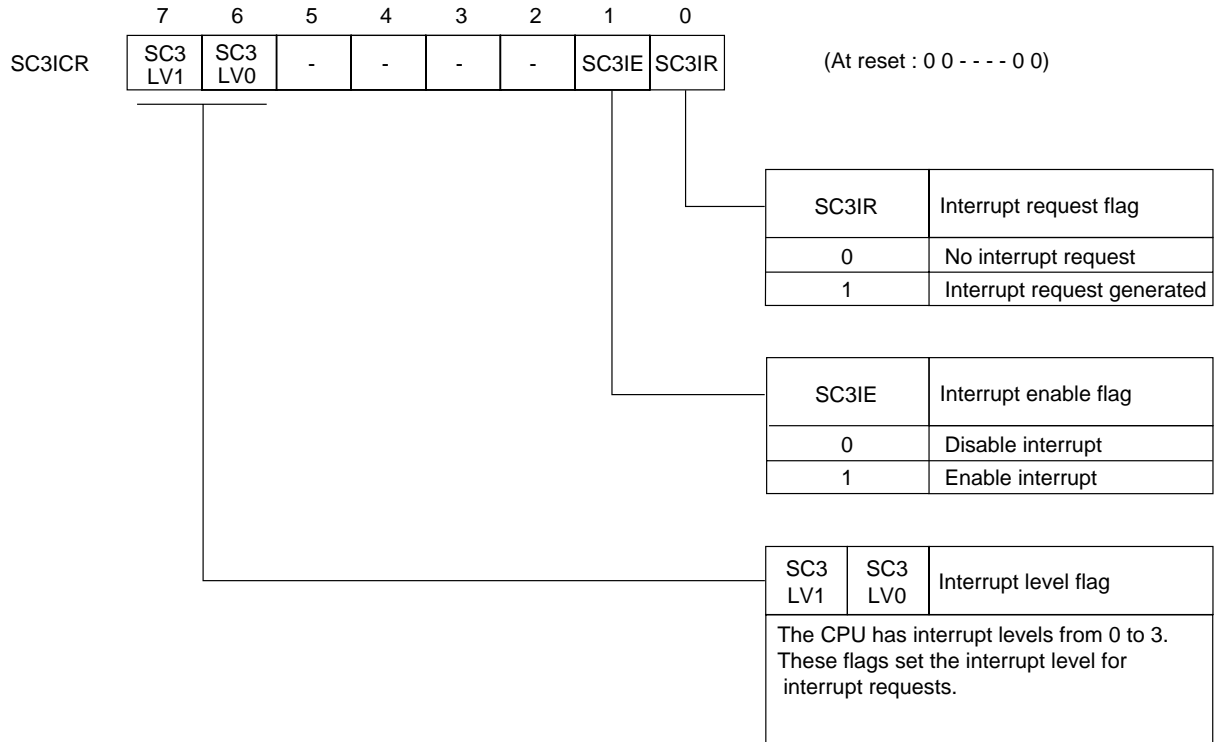


Figure 3-2-21 Serial Interface 3 Interrupt Control Register (SC3ICR : x'03FF9', R/W)

■A/D Converter Interrupt Control Register (ADICR)

The A/D converter interrupt control register (ADICR) controls interrupt level of A/D converter interrupt, interrupt enable flag and interrupt request. Interrupt control register should be operated when the maskable interrupt enable flag (MIE) of PSW is "0".

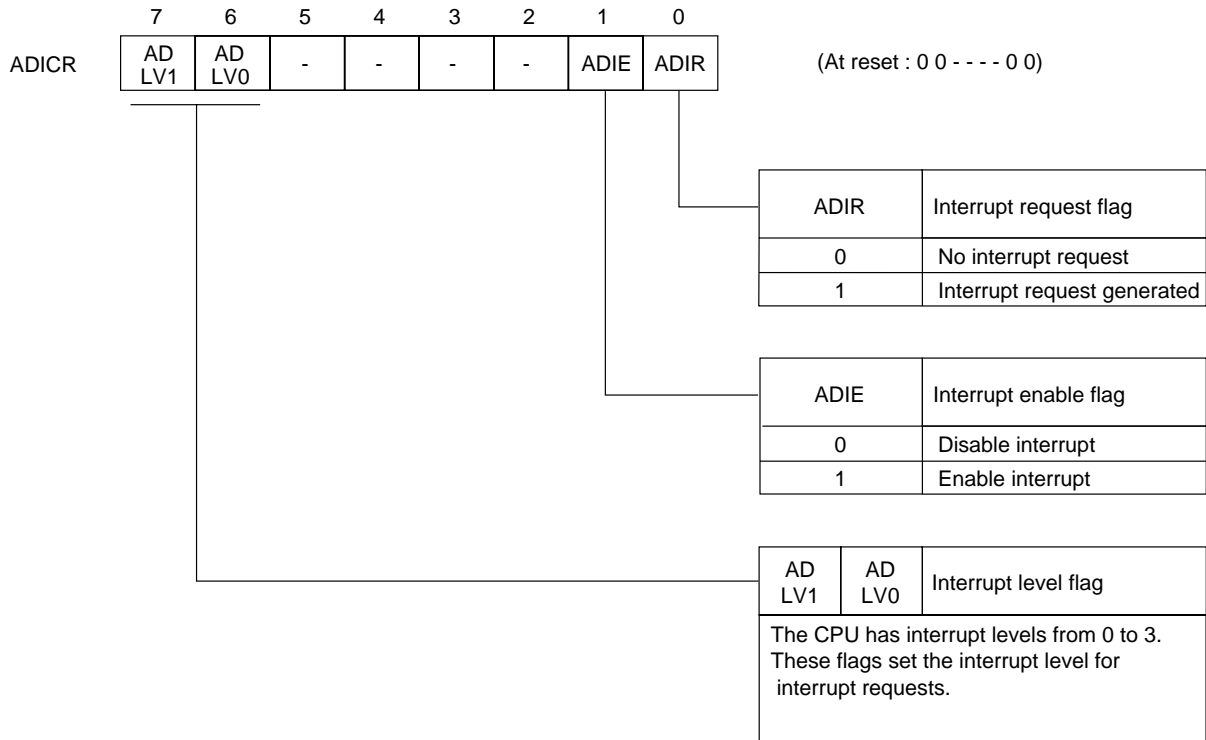


Figure 3-2-22 A/D Converter Interrupt Control Register (ADICR : x'03FFA', R/W)

■ATC 1 Interrupt Control Register (ATC1ICR)

The ATC 1 interrupt control register (ATC1ICR) controls interrupt level of ATC 1 interrupt, interrupt enable flag and interrupt request. Interrupt control register should be operated when the maskable interrupt enable flag (MIE) of PSW is "0".

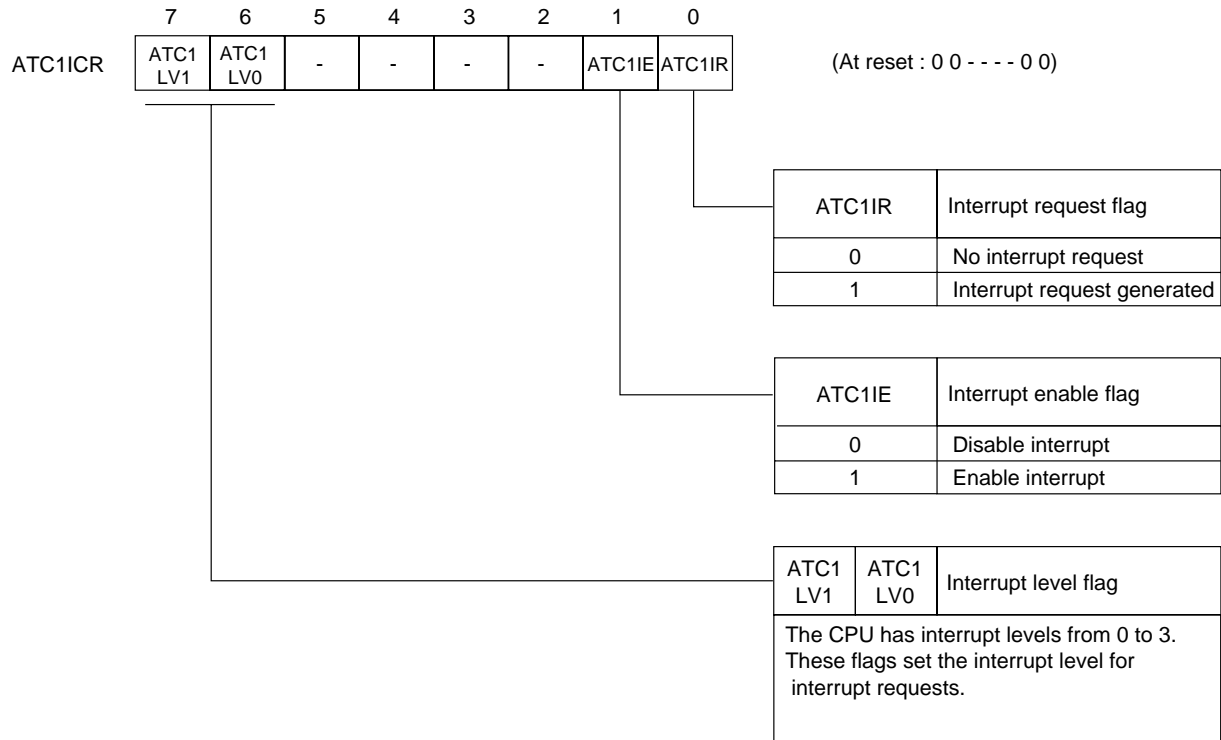


Figure 3-2-23 ATC1 Interrupt Control Register (ATC1ICR : x'03FFC', R/W)

## 3-3 External Interrupts

There are 6 external interrupts in this LSI. The circuit (external interrupt interface) for the external interrupt input signal, is built-in between the external interrupt input pin and the interrupt controller block. This external interrupt interface can manage to do with any kind of external interrupts.

### 3-3-1 Overview

Table 3-3-1 shows the list for functions which external interrupts 0 to 5 can be used.

**Table 3-3-1 External Interrupt Functions**

	External interrupt 0 (IRQ0)	External interrupt 1 (IRQ1)	External interrupt 2 (IRQ2)	External interrupt 3 (IRQ3)	External interrupt 4 (IRQ4)	External interrupt 5 (IRQ5)
External interrupt input pin	P20	P21	P22	P23	P24, P40-P47	P25
Programmable active edge interrupt	√	√	√	√	√ (P24)	√
Both edges interrupt	-	-	√	√	-	-
Key input interrupt	-	-	-	-	√ (P40-P47)	-
Noise filter built-in	√	√	-	-	-	-
AC zero cross detection	-	√	-	-	-	-

### 3-3-2 Block Diagram

External Interrupt 0 Interface, External Interrupt 1 Interface, Block Diagram

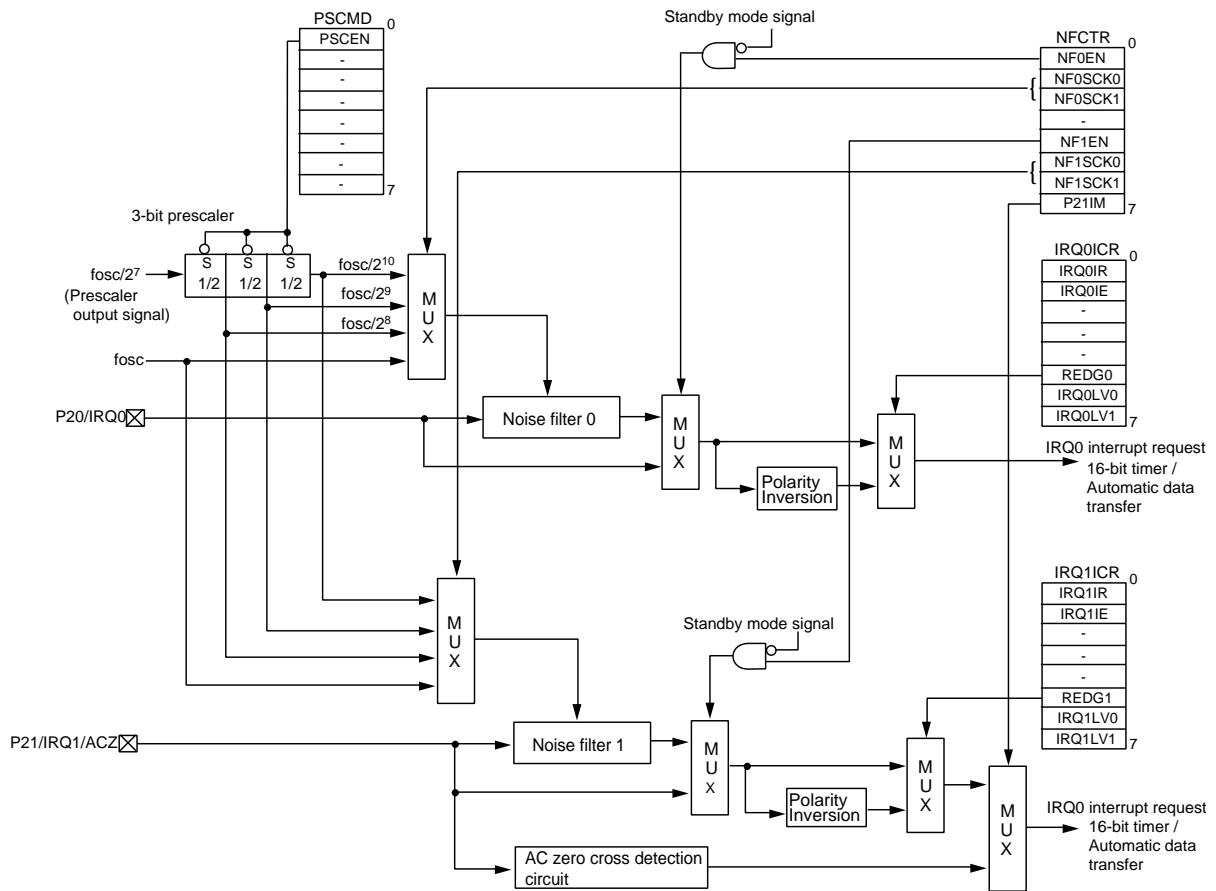


Figure 3-3-1 External Interrupt 0 Interface and External Interrupt 1 Interface Block Diagram

■ External Interrupt 2 Interface, External Interrupt 3 Interface, Block Diagram

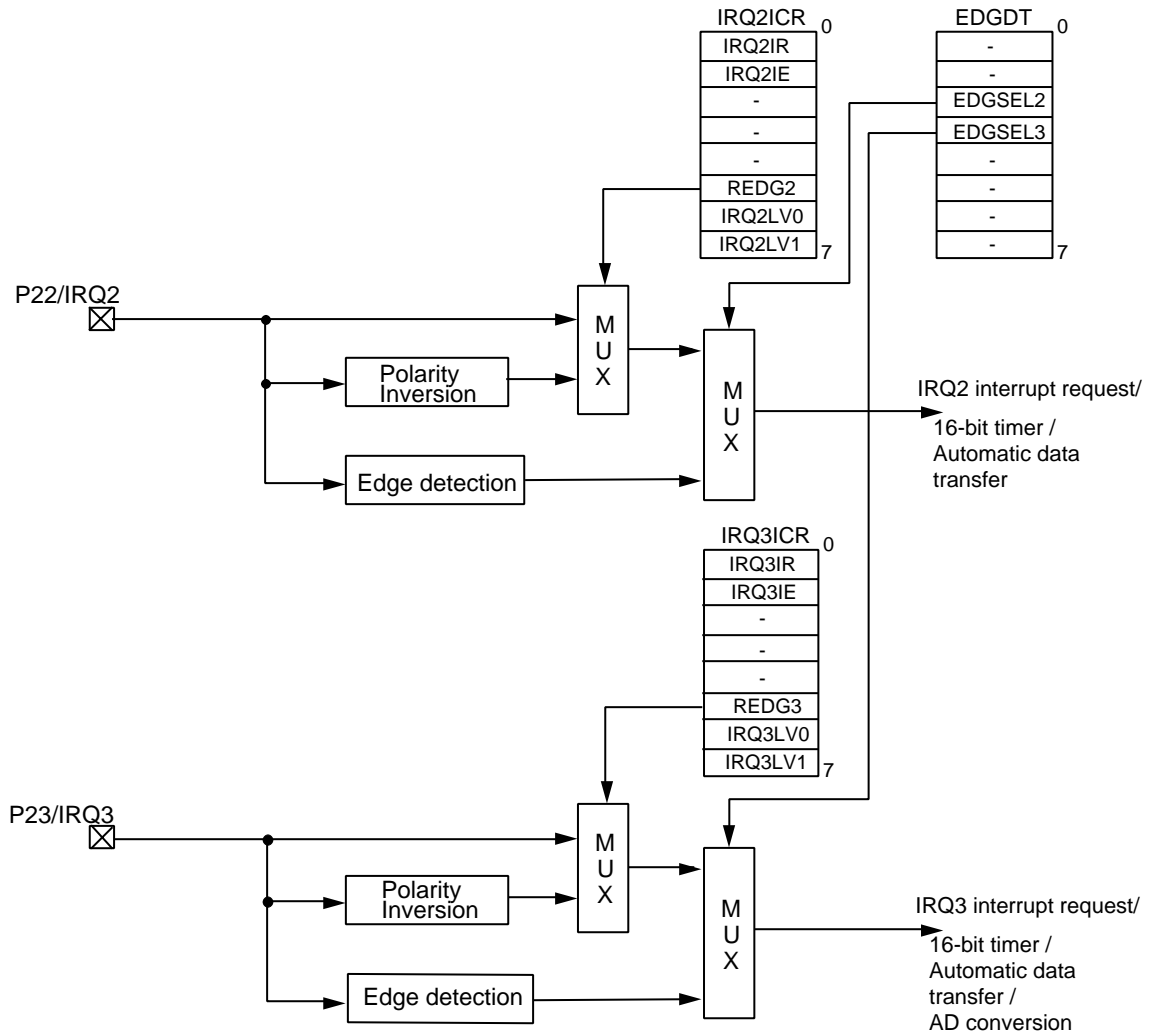


Figure 3-3-2 External Interrupt 2 Interface and External Interrupt 3 Interface, Block Diagram



External Interrupt 4 Interface, External Interrupt 5 Interface, Block Diagram

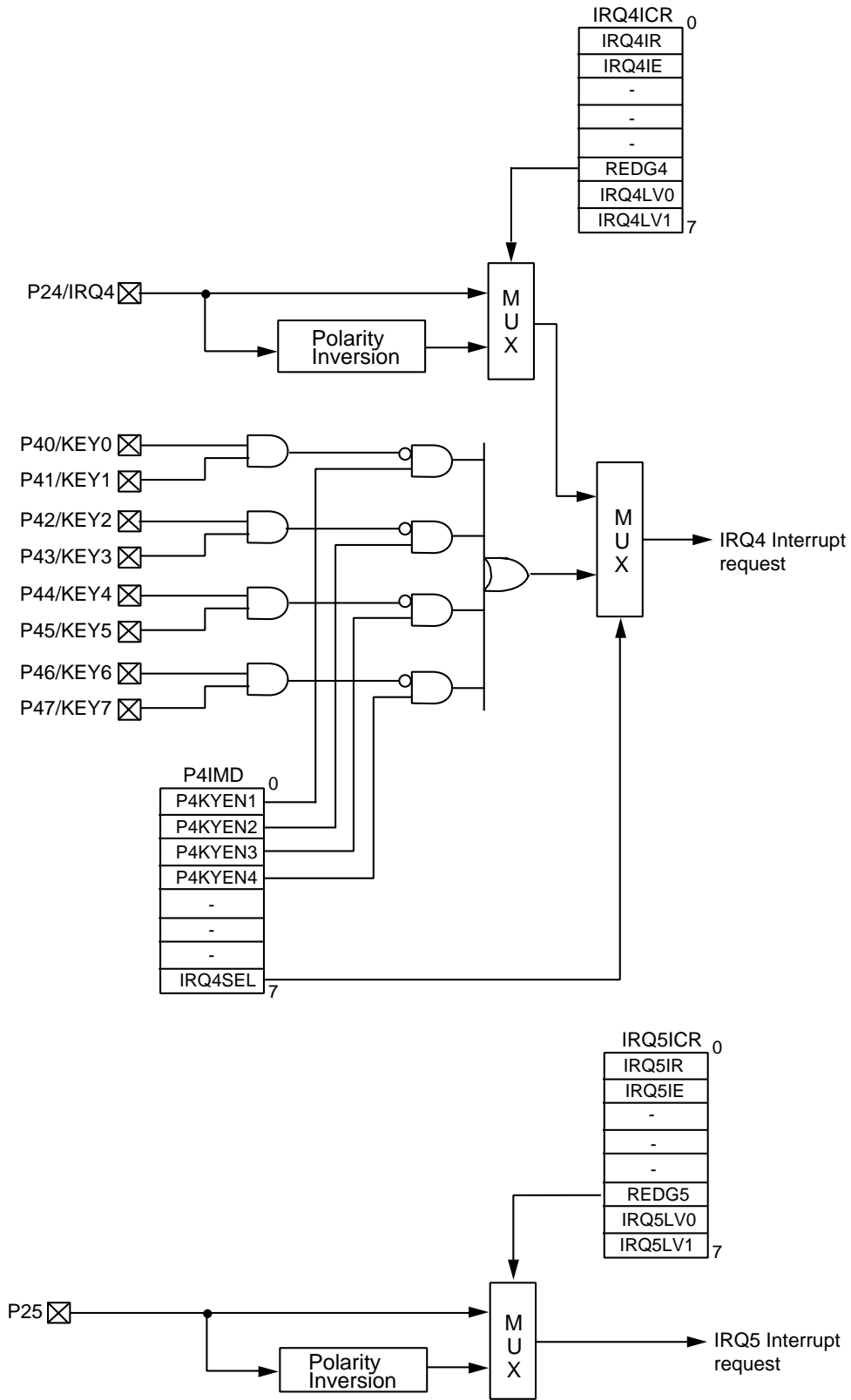


Figure 3-3-3 External Interrupt 4 Interface, External Interrupt 5 Interface, Block Diagram

### 3-3-3 Control Registers

The external interrupt input signal, which operated in each external interrupt 0 to 5 interface generate interrupt requests.

External interrupt 0 to 5 interface are controlled by the external interrupt control register (IRQnICR). And external interrupt interface 0 to 1 are controlled by the noise filter control register (NFCTR) and prescaler control register (PSCMD), external interrupt interface 2 to 3 are controlled by the both edges interrupt control register (EDGDT), and external interrupt interface 4 is controlled the port 4 key interrupt control register (P4IMD).

Table 3-3-2 shows the list of registers, control external interrupt 0 to 5.

**Table 3-3-2 External Interrupt Control Register**

External Interrupt	Register	Address	R/W	Function	Page
External interrupt 0	IRQ0ICR	x'03FE2'	R/W	External interrupt 0 control register	III -18
	NFCTR	x'03F8E'	R/W	Noise filter control register	III -45
	PSCMD	x'03F6F'	R/W	Prescaler control register	V-6
External interrupt 1	IRQ1ICR	x'03FE3'	R/W	External interrupt 1 control register	III -19
	NFCTR	x'03F8E'	R/W	Noise filter control register	III -45
	PSCMD	x'03F6F'	R/W	Prescaler control register	V-6
External interrupt 2	IRQ2ICR	x'03FE4'	R/W	External interrupt 2 control register	III -20
	EDGDT	x'03F8F'	R/W	Both edges interrupt control register	III -46
External interrupt 3	IRQ3ICR	x'03FE5'	R/W	External interrupt 3 control register	III -21
	EDGDT	x'03F8F'	R/W	Both edges interrupt control register	III -46
External interrupt 4	IRQ4ICR	x'03FE6'	R/W	External interrupt 4 control register	III -22
	P4IMD	x'03F3E'	R/W	Port 4 key interrupt control register	III -47
External interrupt 5	IRQ5ICR	x'03FE7'	R/W	External interrupt 5 control register	III -23

R/W : Readable / Writable.

■ Noise Filter Control Register (NFCTR)

The noise filter control register (NFCTR) sets the noise remove function for IRQ0 and IRQ1 and also selects the sampling cycle of noise remove function. And this register also set the AC zero cross detection function for IRQ1.

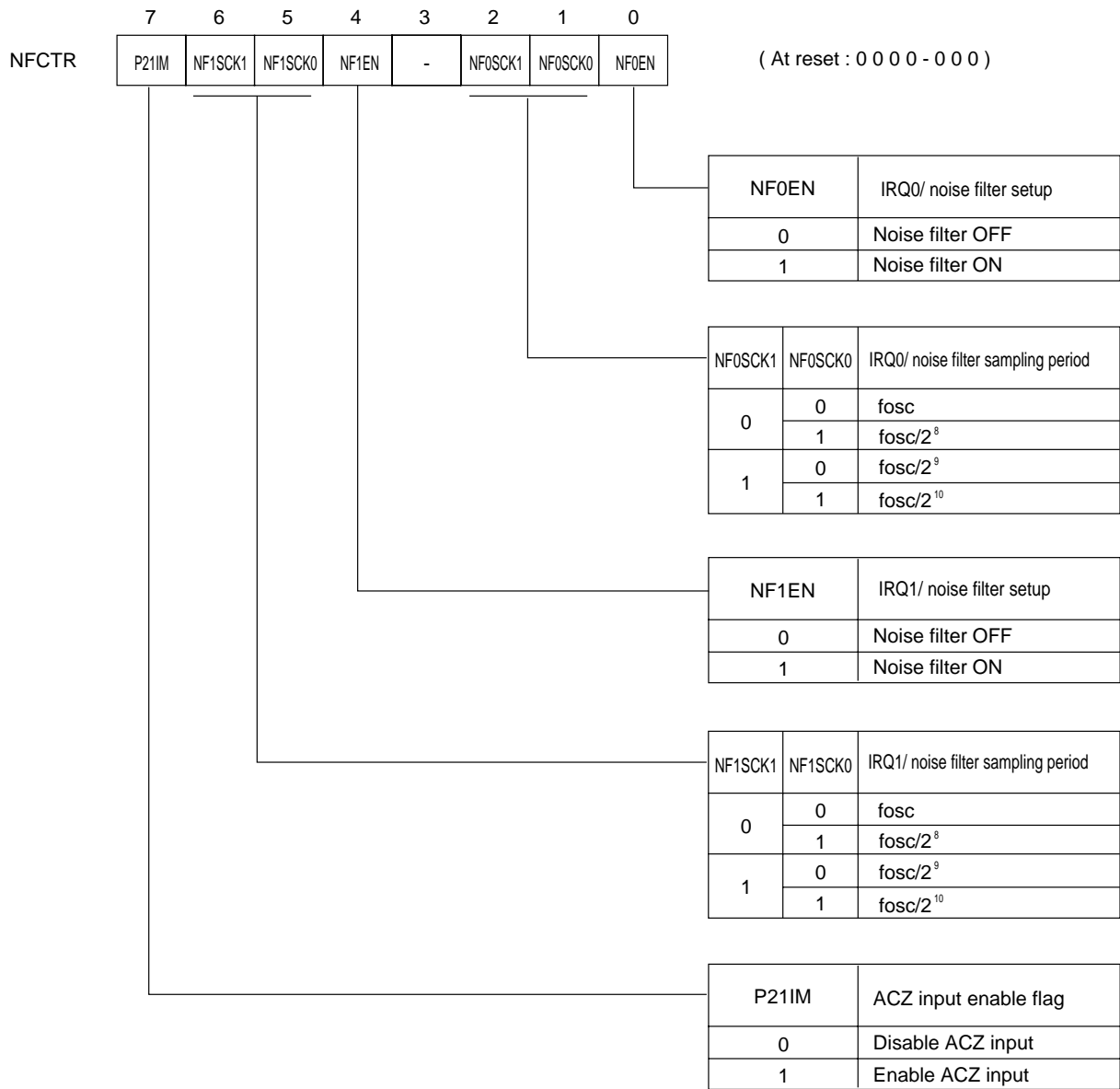
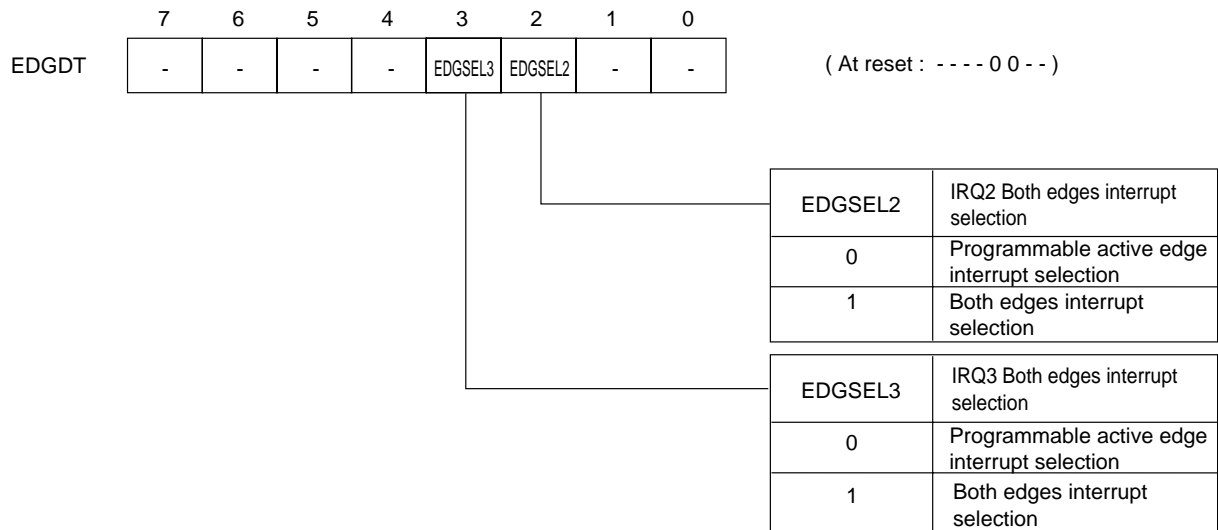


Figure 3-3-4 Noise Filter Control Register (NFCTR : x'03F8E', R/W)

■ Both Edges Interrupt Control Register (EDGDT)

The both edges interrupt control register (EDGDT) selects interrupt edges of IRQ2 and IRQ3. Interrupts are generated at both edges, or at single edge. The external interrupt control register (IRQ2ICR, IRQ3ICR) specifies whether interrupts are generated.



**Figure 3-3-5 Both Edges Interrupt Control Register (EDGDT : x'03F8F', R/W)**

■Port 4 Key Interrupt Control Register (P4IMD)

The port 4 key interrupt control register (P4IMD) selects if key interrupt is approved, and if external interrupt IRQ4 is approved. Also, this register selects, by 2 bits, which pin on port 4 approved key interrupt.

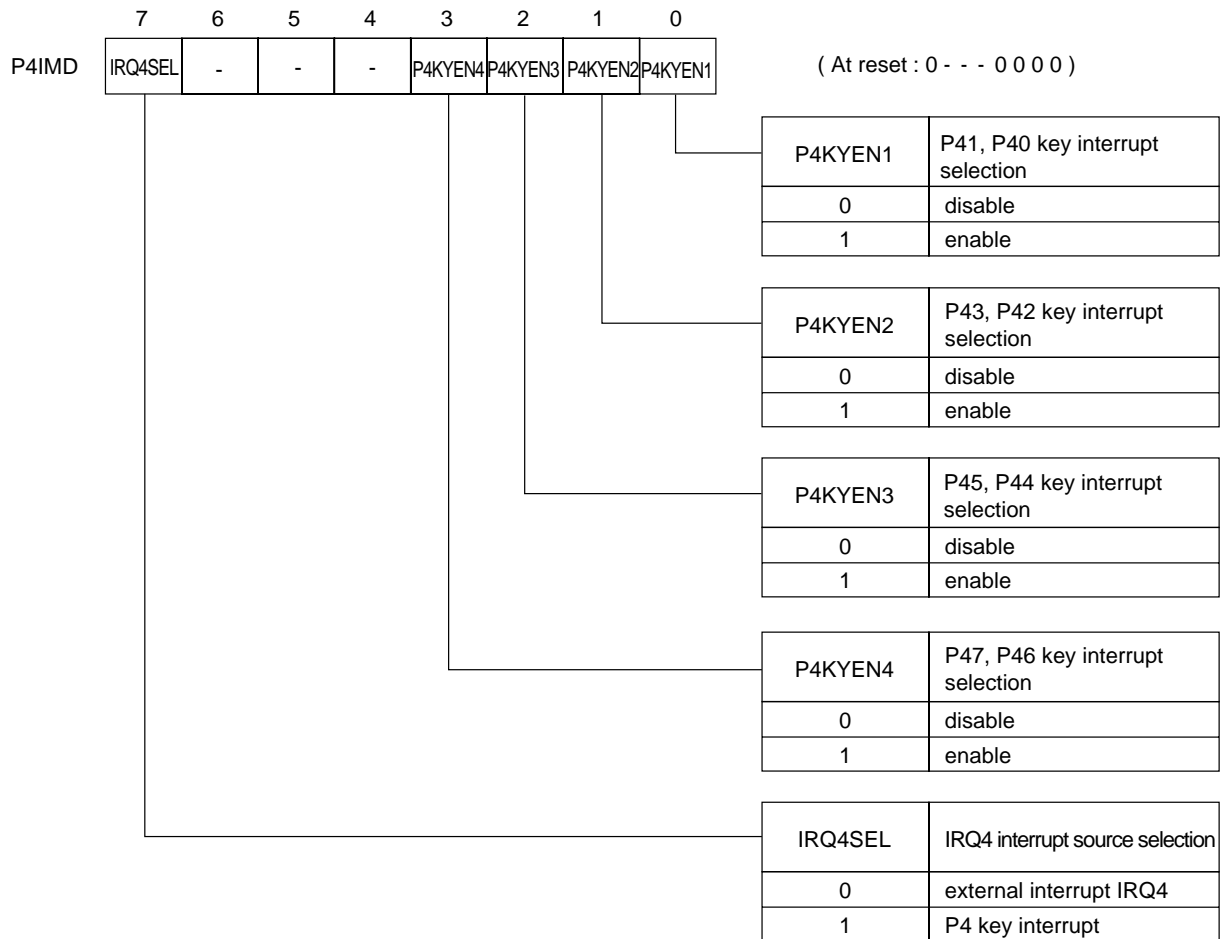


Figure 3-3-6 Port 4 Key Interrupt Control Register (P4IMD : x'03F3E', R/W)

### 3-3-4 Programmable Active Edge Interrupt


■Programmable Active Edge Interrupts (External interrupts 0 to 5)

Through register settings, external interrupts 0 to 5 can generate interrupt at the selected edge either rising or falling edge.


■Programmable Active Edge Interrupt Setup Example (External interrupt 0 to 5)


External interrupt 5 (IRQ5) is generated at the rising edge of the input signal from P25.


The table below provides a setup example for IRQ5.

Setup Procedure	Description
(1) Specify the interrupt active edge. IRQ5ICR (x'3FE7') bp5 : REDG5 = 1	(1) Set the REDG5 flag of the external interrupt 5 control register (IRQ5ICR) to "1" to specify the rising edge as the active edge for interrupts.
(2) Set the interrupt level. IRQ5ICR (x'3FE7') bp7-6 : IRQ5LV1-0= 10	(2) Set the interrupt priority level in the IRQ5LV1-0 flag of the IRQ5ICR register.  If the interrupt request flag has been already set, clear it. [  Chapter 3. 3-1-4 Interrupt flag setup ]
(3) Enable the interrupt. IRQ5ICR (x'3FE7') bp1 : IRQ5IE = 1	(3) Set the IRQ5IE flag of the IRQ5ICR register to "1" to enable the interrupt.

External interrupt 5 is generated at the rising edge of the input signal from P25.

 The Interrupt request flag can be set to "1" at switching the interrupt edge, so specify the interrupt active edge before the interrupt permission.

 The external interrupt pin is recommended to be pull-up in advance.

 When the programmable active edge interrupt is specified for external interrupt 2, 3(IRQ2, IRQ3), set the EDGSELn flag of the both edge interrupt control register (EDGDT) to "0".



Interrupt is not accepted when the both edges interrupt is selected for external interrupt and both following conditions 1), 2) are fulfilled, and also the timings of the following two operations a), b) match.

- 1) The IRWE flag of the memory control register (MEMCTR) is set to "1" (Enable the interrupt request flag to be written by software)
  - 2) Interrupt request flag (IRQnIR) of the external interrupt control register (IRQnICR) is set to "0" (no interrupt request)
- a) Generation of write pulse, which rewrites "0" to the interrupt request flag (IRQnIR) of the IRQnICR.  
b) Generation of interrupt request signal (interrupt edge) from external interface

When using both edges interrupt, rewrite to the interrupt request flag by software in following procedures.

- |   |            |
|---|------------|
| (1) Disable all the maskable interrupts                         | MIE= 0     |
| (2) Disable interrupt   | IRQnIE= 0  |
| (3) Select both edges interrupt                                 | EDGSELn= 1 |
| (4) Set the interrupt level                                     |            |
| (5) Enable the interrupt request flag to be written by software | IRWE= 1    |
| (6) Set the interrupt request flag                              | IRQnIR= 1  |

Needs to be set before interrupt request flag is cleared

- |  |           |
|--|-----------|
| (7) Clear the interrupt request flag                     | IRQnIR= 0 |
| (8) Disable the interrupt flag to be written by software | IRWE= 0   |
| (9) Enable the interrupt                                 | IRQnIE= 1 |
| (10) Enable all the maskable interrupt                   | MIE= 1    |

### 3-3-5 Both Edges Interrupt


■Both Edges Interrupt (External interrupts 2 and 3)

Both edges interrupt can generate interrupt at both the falling edge and the rising edge by the input signal from external input pins. CPU also can be returned from standby mode by both edges interrupt.




■Both Edges Interrupt Setup Example (External interrupts 2 and 3)

External interrupt 2 (IRQ2) is generated at the both edges of the input signal from P22 pin.

An example setup procedure, with a description of each step is shown below.

Setup Procedure	Description
(1) Select the both edges interrupt. EDGDT (x'3F8F') bp2 : EDGSEL2 = 1	(1) Set the EDGSEL2 flag of the both edges interrupt control register (EDGDT) to "1" to select the both edges interrupt.
(2) Set the interrupt level. IRQ2ICR (x'3FE4') bp7-6 : IRQ2LV1-0 = 10	(2) Set the interrupt level by the IRQ2LV1-0 flag of the IRQ2ICR register.  The interrupt request flag of the IRQ2ICR register may be set, so make sure to clear the interrupt request flag (IRQ2IR).  [  Chapter 3 3-1-4 Interrupt flag setup ]
(3) Enable the interrupt. IRQ2ICR (x'3FE4') bp1 : IRQ2IE = 1	(3) Set the IRQ2IE flag of the IRQ2ICR register to "1" to enable the interrupt.

At the both edge of the input signal from P22 pin, an external interrupt 2 is generated .

-  When the both edge interrupt is selected, the interrupt request generates at the both edge, regardless of the REDGn flag of the external interrupt control register (IRQnICR).
-  The interrupt request flag may be set to "1" at switching the interrupt edge. So, clear the interrupt request flag before the interrupt enable. Also, select the both edge interrupt before the interrupt enable.
-  The external interrupt pin is recommended to be pull-up, in advance.



### 3-3-6 Key Input Interrupt

#### ■Key Input Interrupt (External interrupt 4)

This LSI can set port 4 pin (P40 - P47) by 2 bits to key input pin. Key input interrupt can generate an interrupt at the falling edge, if at least 1 key input pin outputs low level.



Key input pin should be pull-up in advance.




When key input interrupt is used, set the IRQ4SEL flag of the port4 key interrupt control register (P4IMD) to "1".



When key input interrupt is used, set the REDG4 flag of the external interrupt 4 control register (IRQ4ICR) to "0" (falling edge).

■Key Input Interrupt Setup Example (External interrupt 4)

After P40 to P43 of port 4 are set to key input pins and key is input (low level), the external interrupt 4 (IRQ4) is generated. An example setup procedure, with a description of each step is shown below.

Setup Procedure	Description
(1) Set the key input pin to input. P4DIR (x'3F34') bp3-0 : P4DIR3-0 = 0000	(1) Set the P4DIR3-0 flag of the port 4 direction control register (P4DIR) to "0000" to set P40 to P43 pins to input pins.
(2) Set the pull-up resistance. P4PLUD (x'3F44') bp3-0 : P4PLUD3-0 = 1111	(2) Set the P4PLUD 3-0 flag of the port 4 pull-up/down resistance control register (P4PLUD) to "1111" to add the pull-up resistance to P40 to P43 pins.
(3) Select the key input interrupt. P4IMD (x'3F3E') bp7 : IRQ4SEL = 1	(3) Set the IRQ4SEL flag of the port 4 key interrupt control register (P4IMD) to "1" to select the external interrupt 4 source to the port 4 key interrupt.
(4) Select the key input pin. P4IMD (x'3F3E') bp1-0 : P4KYEN2-1= 11	(4) Set the P4KYEN 2-1 flag of the port 4 key interrupt control register (P4IMD) to "11" to set P40 to P43 pins to key input pins.
(5) Set the interrupt level. IRQ4ICR (x'3FE6') bp7-6 : IRQ4LV1-0= 10	(5) Set the interrupt level by the IRQ4LV1-0 flag of the IRQ4ICR register.  If the interrupt request flag has been already set, clear the it. [  Chapter 3 3-1-4. Interrupt flag setup ]
(6) Enable the interrupt. IRQ4ICR (x'3FE6') bp1 : IRQ4IE = 1	(6) Set the IRQ4IE flag of the IRQ4ICR register to "1" to enable the interrupt.

Note : The above (3) and (4) are set at the same time.

If there is at least one input signal, from the P40 to P43 pins, shows low level, the external interrupt 4 is generated at the falling edge.



The setup of the key input should be done before the interrupt is enabled.

### 3-3-7 Noise Filter

#### ■Noise Filter (External interrupts 0 to 1)

Noise filter reduce noise by sampling the input waveform from the external interrupt pins (IRQ0, IRQ1). Its sampling cycle can be selected from 4 types ( $f_{osc}$ ,  $f_{osc}/2^8$ ,  $f_{osc}/2^9$ ,  $f_{osc}/2^{10}$ ).

#### ■Noise Remove Selection (External interrupts 0 to 1)

Noise remove function can be used by setting the NFnEN flag of the noise filter control register (NFCTR) to "1".

**Table 3-3-3 Noise Remove Function**

NFnEN	IRQ0 input (P20)	IRQ1 input (P21)
0	IRQ0 Noise filter OFF	IRQ1 Noise filter OFF
1	IRQ0 Noise filter ON	IRQ1 Noise filter ON

#### ■Sampling Cycle Setup (External interrupts 0 and 1)

The sampling cycle of noise remove function can be set by the NFnSCK 1- 0 flag of the NFCTR register.

**Table 3-3-4 Sampling Cycle / Time of Noise Remove Function**

NFnCKS1	NFnCKS0	Sampling cycle	High-Speed oscillation			
			$f_{osc}=20$ MHz		$f_{osc}=8$ MHz	
0	0	$f_{osc}$	20 MHz	50 ns	8 MHz	125 ns
	1	$f_{osc}/2^8$	78.13 kHz	12.80 $\mu$ s	31.25 kHz	32 $\mu$ s
1	0	$f_{osc}/2^9$	39.06 kHz	25.60 $\mu$ s	15.62 kHz	64 $\mu$ s
	1	$f_{osc}/2^{10}$	19.53 kHz	51.20 $\mu$ s	7.81 kHz	128 $\mu$ s



When " $f_{osc}/2^8$ ", " $f_{osc}/2^9$ " or " $f_{osc}/2^{10}$ " is selected as a sampling cycle, set the prescaler ON by setting the PSCEN flag of the prescaler control register (PSCMD) to "1".

[  Chapter 5 Prescaler ]

■ Noise Remove Function Operation (External interrupts 0 to 1)

After sampling the input signal to the external interrupt pins ( IRQ0, IRQ1) by the set sampling time, if the same level comes continuously three times, that level is sent to the inside of LSI. If the same level does not come continuously three times, the previous level is sent. It means that only the signal with the width of more than " Sampling time X 3 sampling clock " can pass through the noise filter, and other much narrower signals are removed, because those are regarded as noise.

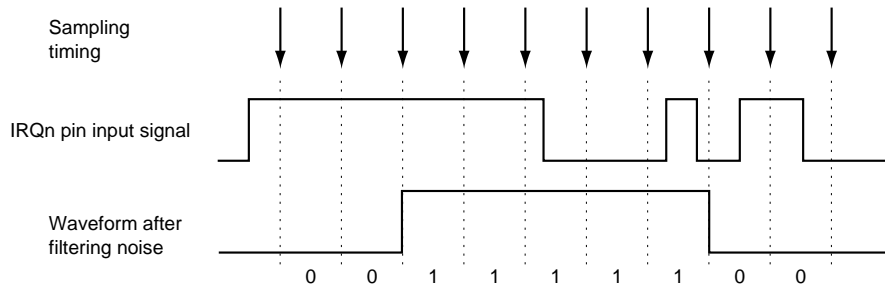



Figure 3-3-7 Noise Remove Function Operation



Noise filter can not be used at STOP mode, HALT mode and SLOW mode.

### ■ Noise Filter Setup Example (External interrupt 0 and 1)

Noise remove function is added to the input signal from P20 pin to generate the external interrupt 0 (IRQ0) at the rising edge. The sampling clock is set to fosc, and the operation state is fosc = 20 MHz. An example setup procedure, with a description of each step is shown below.

Setup Procedure	Description
(1) Specify the interrupt active edge. IRQ0ICR (x'3FE2') bp5 : REDG0 = 1	(1) Set the REDG0 flag of the external interrupt 0 control register (IRQ0ICR) to "1" to specify the interrupt active edge to the rising edge.
(2) Select the sampling clock. NFCTR (x'3F8E') bp2-1 : NF0SCK1-0 = 00	(2) Select the sampling clock to fosc by the NF0SCK 1-0 flag of the noise filter control register (NFCTR).
(3) Set the noise filter operation. NFCTR (x'3F8E') bp0 : NF0EN = 1	(3) Set the NF0EN flag of the NFCTR register to "1" to add the noise filter operation.
(4) Set the interrupt level. IRQ0ICR (x'3FE2') bp7-6 : IRQ0LV1-0 = 10	(4) Set the interrupt level by the IRQ0LV 1-0 flag of the IRQ0ICR register.  If the interrupt request flag has been already set, clear the request flag. [  Chapter 3 3-1-4. Interrupt flag setup ]
(5) Enable the interrupt. IRQ0ICR (x'3FE2') bp1 : IRQ0IE = 1	(5) Set the IRQ0IE flag of the IRQ0ICR register to "1" to enable the interrupt.

Note : The above (2) and (3) are set at the same time.

The input signal from the P20 pin generates the external interrupt 0 at the rising edge of the signal, after passing through the noise filter.



The setup of the noise filter should be done before the interrupt is enabled.



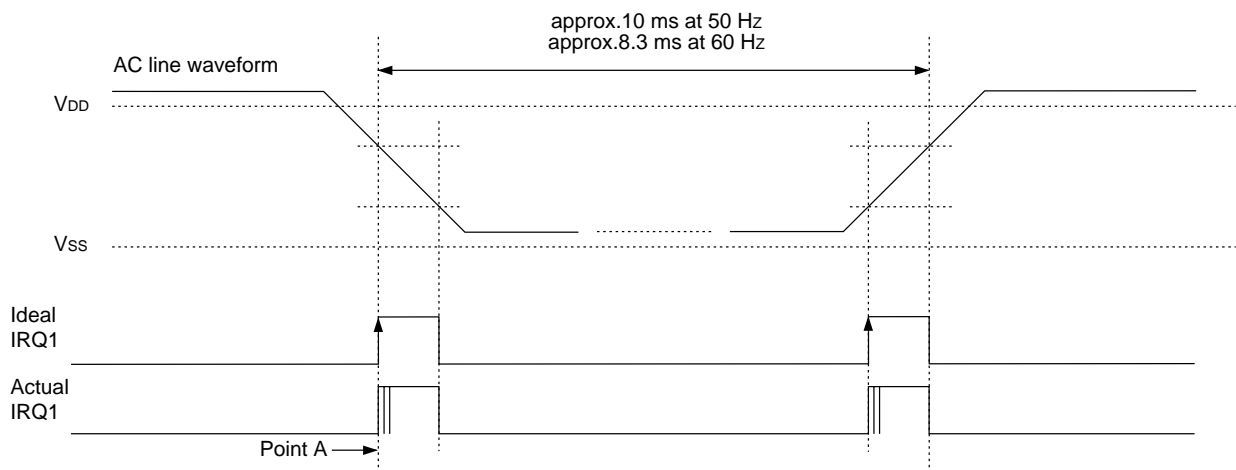
The external interrupt pins are recommended to be pull-up in advance.

### 3-3-8 AC Zero-Cross Detector

This LSI has AC zero-cross detector circuit. The P21 / ACZ pin is the input pin of AC zero-cross detector circuit. AC zero-cross detector circuit outputs the high level when the input level is at the middle, and outputs the low level at other level.

■ AC Zero-Cross Detector (External interrupt 1)

AC zero-cross detector sets the IRQ1 pin to the high level when the input signal (P21/ACZ pin) is at intermediate range. At the other level, IRQ1 pin is set to the low level. AC zero-cross can be detected by setting the P21IM flag of the noise filter control register (NFCTR) to "1".



**Figure 3-3-8 AC Line Waveform and IRQ1 Generation Timing**

Actual IRQ1 interrupt request is generated several times at crossing the 1/2 V<sub>DD</sub> of AC line waveform. So, the filtering operation by the program is needed.




The interrupt request is generated at the rising edge of the AC zero-cross detector signal.

### ■AC Zero-Cross Detector Setup Example (External interrupt 1)

AC zero-cross detector generates the external interrupt 1 (IRQ1) by using P21/ACZ pin.

An example setup procedure, with a description of each step is shown below.

Setup Procedure	Description
(1) Select the AC zero-cross detector signal. NFCTR (x'3F8E') bp7 : P21IM = 1	(1) Set the P21IM flag of the noise filter control register (NFCTR) to "1" to select the AC zero-cross detector signal as the external interrupt 1 generation factor.
(2) Set the interrupt level. IRQ1ICR (x'3FE3') bp7-6 : IRQ1LV1-0= 10	(2) Set the interrupt level by the IRQ1LV 1-0 flag of the IRQ1ICR register.  If the interrupt request flag has been already set, clear the interrupt flag. [  Chapter 3 3-1-4. Interrupt flag setup ]
(3) Enable the interrupt. IRQ1ICR (x'3FE3') bp1 : IRQ1IE = 1	(3) Set the IRQ1IE flag of the IRQ1ICR register to "1" to enable the interrupt.

When the input signal level from P21/ACZ pin crosses  $1/2 V_{DD}$ , the external interrupt 1 is generated.







## 4-1 Overview

### 4-1-1 I/O Port Diagram

A total of 89 pins on this LSI, including those shared with special function pins, are allocated for the 12 I/O ports of ports 0 to 8, port A, port C and port D. Each I/O port is assigned to its corresponding special function register area in memory. I/O ports are operated in byte or bit units in the same way as RAM.

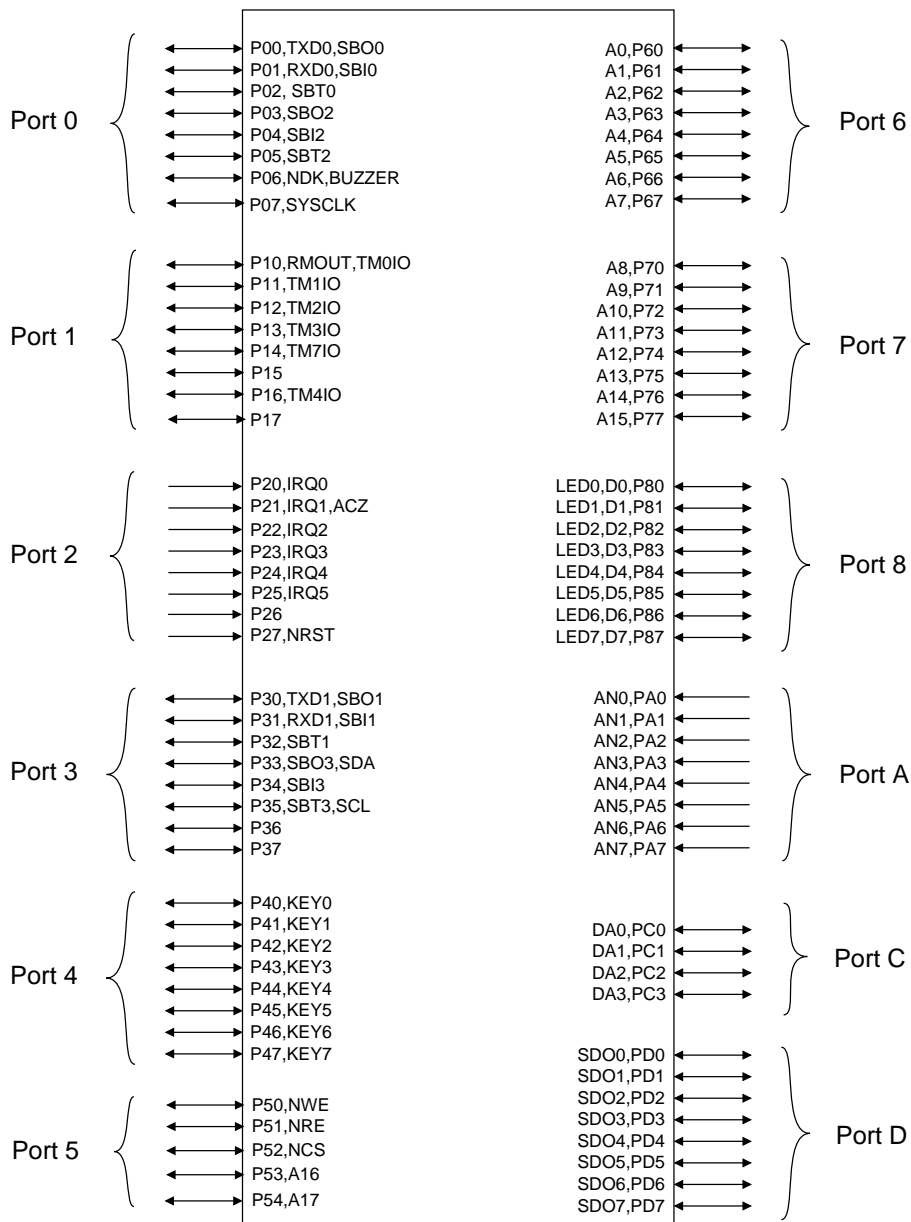


Figure 4-1-1 I/O Port Functions

## 4-1-2 I/O Port Status at Reset

**Table 4-1-1 I/O Port Status at Reset (Single chip mode)**

Port Name	I/O mode	Pull-up / Pull-down resistor	I/O port, special functions
Port 0	Input mode	No pull-up resistor	I/O port
Port 1	Input mode	No pull-up resistor	I/O port
Port 2	Input mode	P27 : Pull-up resistor Others : No pull-up resistor	I/O port
Port 3	Input mode	No pull-up resistor	I/O port
Port 4	Input mode	No pull-up / pull-down resistor	I/O port
Port 5	Input mode	No pull-up resistor	I/O port
Port 6	Input mode	No pull-up resistor	I/O port
Port 7	Input mode	No pull-up / pull-down resistor	I/O port
Port 8	Input mode	No pull-up resistor	I/O port
Port A	Input mode	No pull-up / pull-down resistor	I/O port
Port C	Input mode	No pull-up resistor	I/O port
Port D	Input mode	No pull-up resistor	I/O port

**Table 4-1-2 I/O Port Status at Reset (Memory expansion mode and Processor mode)**

Port Name	I/O mode	Pull-up / Pull-down resistor	I/O port, special functions
Port 0	P07 : Output mode Others : Input mode	No pull-up resistor	I/O port *
Port 1	Input mode	No pull-up resistor	I/O port
Port 2	Input mode	P27 : Pull-up resistor Others : No pull-up resistor	I/O port
Port 3	Input mode	No pull-up resistor	I/O port
Port 4	Input mode	No pull-up / pull-down resistor	I/O port
Port 5	Output mode	No pull-up resistor	NWE, NRE, NCS, A16, A17
Port 6	Output mode	No pull-up resistor	A0 to A7
Port 7	Output mode	No pull-up / pull-down resistor	A8 to A15
Port 8	Input mode	No pull-up resistor	D0 to D7
Port A	Input mode	No pull-up / pull-down resistor	I/O port
Port C	Input mode	No pull-up resistor	I/O port
Port D	Input mode	No pull-up resistor	I/O port

\* P06 is used as NDK pin (input mode).

P07 is used as system clock output pin (output mode).



The values of pull-up/pull-down resistors should be calculated in following ways based on the electrical characteristics in LSI User's Manual of each model.

**How to determine pull-up resistor value**

ex) When pins maintain the low level guaranteed performance (not 0 V) as specified in the electrical characteristics,  
and at  $V_{DD} = 5\text{ V}$ ,  $V_{IN} = 1.5\text{ V}$ ,

input current is min. = - 30  $\mu\text{A}$ , typ = - 100  $\mu\text{A}$ , max. = - 300  $\mu\text{A}$ .

( - means current passing from microcontroller.)

When convert above values to resistor value, typ = 35 k $\Omega$ .

Note that this value varies wildly depending on the temperature.

In temperature variation from - 40  $^{\circ}\text{C}$  to 85  $^{\circ}\text{C}$ , the resistor value varies from min. = 11.7 k $\Omega$  to max. = 117 k $\Omega$ .

**How to determine pull-down resistor value**

ex) When pins maintain the high level guaranteed performance (not  $V_{DD}$ ) as specified in the electrical characteristics,

and at  $V_{DD} = 5\text{ V}$ ,  $V_{IN} = 3.5\text{ V}$ ,

input current is min. = - 30  $\mu\text{A}$ , typ = - 100  $\mu\text{A}$ , max. = - 300  $\mu\text{A}$ .

When convert these values to resistance value, typ = 35 k $\Omega$ .

Note that this value varies wildly depending on the temperature.

In temperature variation from - 40  $^{\circ}\text{C}$  to 85  $^{\circ}\text{C}$ , the resistor value varies from min. = 11.7 k $\Omega$  to max. = 117 k $\Omega$ .

### 4-1-3 Control Registers

Ports 0 to 8, A, C and D are controlled by the data output register (PnOUT), the data input register (PnIN), the I/O direction control register (PnDIR), the pull-up resistor control register (PnPLU) and the pull-up / pull-down resistor control register (PnPLUD) and registers (P1OMD, P1TCNT, PAIMD, PDSYO, EXADV, FLOAT) that control special function pin.

Table 4-1-3 shows the registers to control ports 0 to 8, A, C and D ;

**Table 4-1-3 I/O Port Control Registers List (1/2)**

	Register	Address	R/W	Function	Page
Port 0	P0OUT	x'03F10'	R/W	Port 0 output register	IV-8
	P0IN	x'03F20'	R	Port 0 input register	IV-8
	P0DIR	x'03F30'	R/W	Port 0 direction control register	IV-8
	P0PLU	x'03F40'	R/W	Port 0 pull-up resistor control register	IV-8
Port 1	P1OUT	x'03F11'	R/W	Port 1 output register	IV-14
	P1IN	x'03F21'	R	Port 1 input register	IV-14
	P1DIR	x'03F31'	R/W	Port 1 direction control register	IV-14
	P1PLU	x'03F41'	R/W	Port 1 pull-up resistor control register	IV-14
	P1OMD	x'03F2F'	R/W	Port 1 output mode register	IV-15
	P1TCNT	x'03F7E'	R/W	Port 1 output control register	IV-16
Port 2	P2OUT	x'03F12'	R/W	Port 2 output register	IV-20
	P2IN	x'03F22'	R	Port 2 input register	IV-20
	P2PLU	x'03F42'	R/W	Port 2 pull-up resistor control register	IV-20
Port 3	P3OUT	x'03F13'	R/W	Port 3 output register	IV-23
	P3IN	x'03F23'	R	Port 3 input register	IV-23
	P3DIR	x'03F33'	R/W	Port 3 direction control register	IV-23
	P3PLU	x'03F43'	R/W	Port 3 pull-up resistor control register	IV-23
Port 4	P4OUT	x'03F14'	R/W	Port 4 output register	IV-29
	P4IN	x'03F24'	R	Port 4 input register	IV-29
	P4DIR	x'03F34'	R/W	Port 4 direction control register	IV-29
	P4PLUD	x'03F44'	R/W	Port 4 pull-up / pull-down resistor control register	IV-29

**Table 4-1-4 I/O Port Control Registers List (2/2)**

	Register	Address	R/W	Function	Page
Port 5	P5OUT	x'03F15'	R/W	Port 5 output register	IV-33
	P5IN	x'03F25'	R	Port 5 input register	IV-33
	P5DIR	x'03F35'	R/W	Port 5 direction control register	IV-33
	P5PLU	x'03F45'	R/W	Port 5 pull-up resistor control register	IV-33
Port 6	P6OUT	x'03F16'	R/W	Port 6 output register	IV-37
	P6IN	x'03F26'	R	Port 6 input register	IV-37
	P6DIR	x'03F36'	R/W	Port 6 direction control register	IV-37
	P6PLU	x'03F46'	R/W	Port 6 pull-up resistor control register	IV-37
Port 7	P7OUT	x'03F17'	R/W	Port 7 output register	IV-40
	P7IN	x'03F27'	R	Port 7 input register	IV-40
	P7DIR	x'03F37'	R/W	Port 7 direction control register	IV-40
	P7PLUD	x'03F47'	R/W	Port 7 pull-up / pull-down resistor control register	IV-40
Port 8	P8OUT	x'03F18'	R/W	Port 8 output register	IV-44
	P8IN	x'03F28'	R	Port 8 input register	IV-44
	P8DIR	x'03F38'	R/W	Port 8 direction control register	IV-44
	P8PLU	x'03F48'	R/W	Port 8 pull-up resistor control register	IV-44
Port A	PAIN	x'03F2A'	R	Port A input register	IV-47
	PAIMD	x'03F3A'	R/W	Port A input mode register	IV-47
	PAPLUD	x'03F4A'	R/W	Port A pull-up / pull-down resistor control register	IV-47
Port C	PCOUT	x'03F1C'	R/W	Port C output register	IV-51
	PCIN	x'03F2C'	R	Port C input register	IV-51
	PCDIR	x'03F3C'	R/W	Port C direction control register	IV-51
	PCPLU	x'03F4C'	R/W	Port C pull-up resistor control register	IV-51
Port D	PDOUT	x'03F1D'	R/W	Port D output register	IV-54
	PDIN	x'03F2D'	R	Port D input register	IV-54
	PDDIR	x'03F3D'	R/W	Port D direction control register	IV-54
	PDPLU	x'03F4D'	R/W	Port D pull-up resistor control register	IV-54
	PDSYO	x'03F1F'	R/W	Port D synchronous output control register	IV-55
Pin control	EXADV	x'03F0E'	R/W	Address output control register	IV-34,IV-41
	FLOAT	x'03F2E'	R/W	Pull-up / Pull-down resistor selection, pin control register	IV-30,IV-41, IV-48,IV-55

## 4-2 Port 0

### 4-2-1 Description

#### ■General Port Setup

Each bit of the port 0 control I/O direction register (P0DIR) can be set individually to set each pin as input or output. The control flag of the port 0 direction control register (P0DIR) should be set to "1" for output mode, and "0" for input mode.


To read input data of pin, set the control flag of the port 0 direction control register (P0DIR) to "0" and read the value of the port 0 input register (P0IN).

To output data to pin, set the control flag of the port 0 direction control register (P0DIR) to "1" and write the value of the port 0 output register (P0OUT).

Each pin can be set individually if pull-up resistor is added or not, by the port 0 pull-up resistor control register (P0PLU). Set the control flag of the port 0 pull-up resistor control register (P0PLU) to "1" to add pull-up resistor.


#### ■Special Function Pin Setup

P00 to P02 are used as I/O pin for serial interface 0, as well. P00 is output pin of the serial interface 0 transmission data, and UART 0 transmission data. When the SC0SBOS flag of the serial interface 0 mode register 1 (SC0MD1) is "1", P00 is serial data output pin. P01 is the input pin of the serial interface 0 reception data, and UART 0 transmission data. P02 is I/O pin of the serial interface 0 clock. When the SC0SBTS flag of serial interface 0 mode register 1 (SC0MD1) is "1", P02 is serial clock output pin. P00 and P02 can be selected as either an push-pull output or Nch open-drain output by the serial interface 0 port control register (SC0ODC).

[  Chapter 11 11-2. Control registers ]

P03 to P05 are used as I/O pin for serial interface 2, as well. P03 is output pin of the serial interface 2 transmission data. When the SC2SBOS flag of the serial interface 2 mode register 1 (SC2MD1) is "1", P03 is serial data output pin. P04 is the serial interface 2 reception data input pin. P05 is I/O pin of the serial interface 2 clock. When the SC2SBTS flag of serial interface 2 mode register 1 (SC2MD1) is "1", P05 is serial clock output pin.

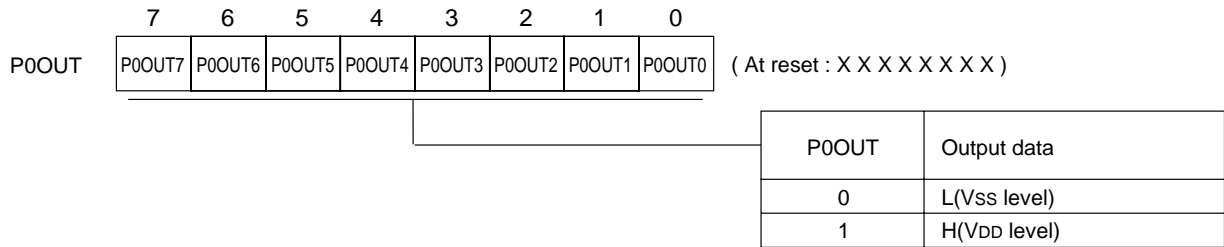
P03 and P05 can be selected as either an push-pull output or Nch open-drain output by the serial interface 2 port control register (SC2ODC).

[  Chapter 13 13-2. Control registers ]

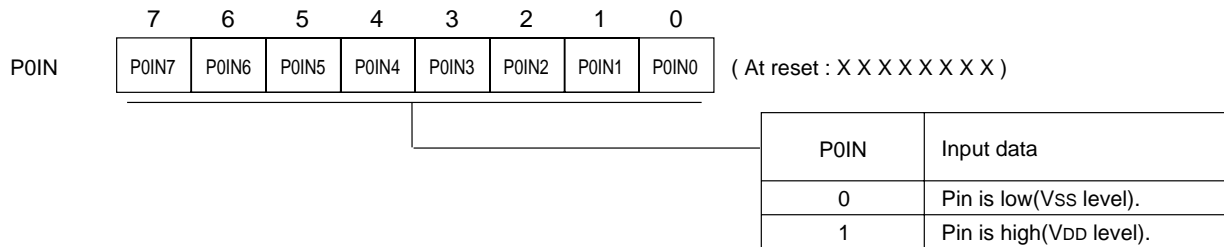
P06 is used as a buzzer output pin, as well. When the bp7 of the oscillation stabilization control register (DLYCTR) is "1", buzzer output is enabled. In processor mode or memory expansion mode, data acknowledge mode input pin is selected. In those mode, input mode is always selected.

In processor mode or memory expansion mode, P07 is system clock output pin. In those mode, output mode is always selected.

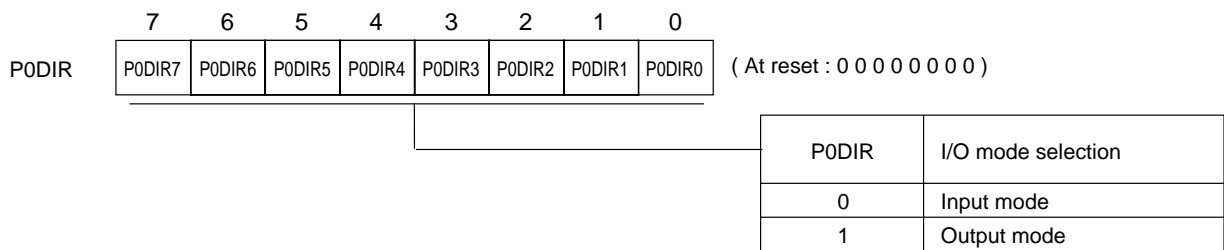
### 4-2-2 Registers



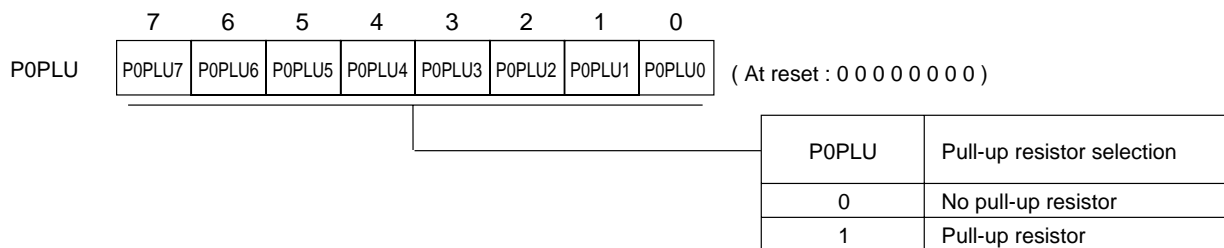
Port 0 output register (P0OUT : x'03F10', R/W)



Port 0 input register (P0IN : x'03F20', R)



Port 0 direction control register (P0DIR : x'03F30', R/W)



Port 0 pull-up resistor control register (P0PLU : x'03F40', R/W)

**Figure 4-2-1 Port 0 Registers**



### 4-2-3 Block Diagram

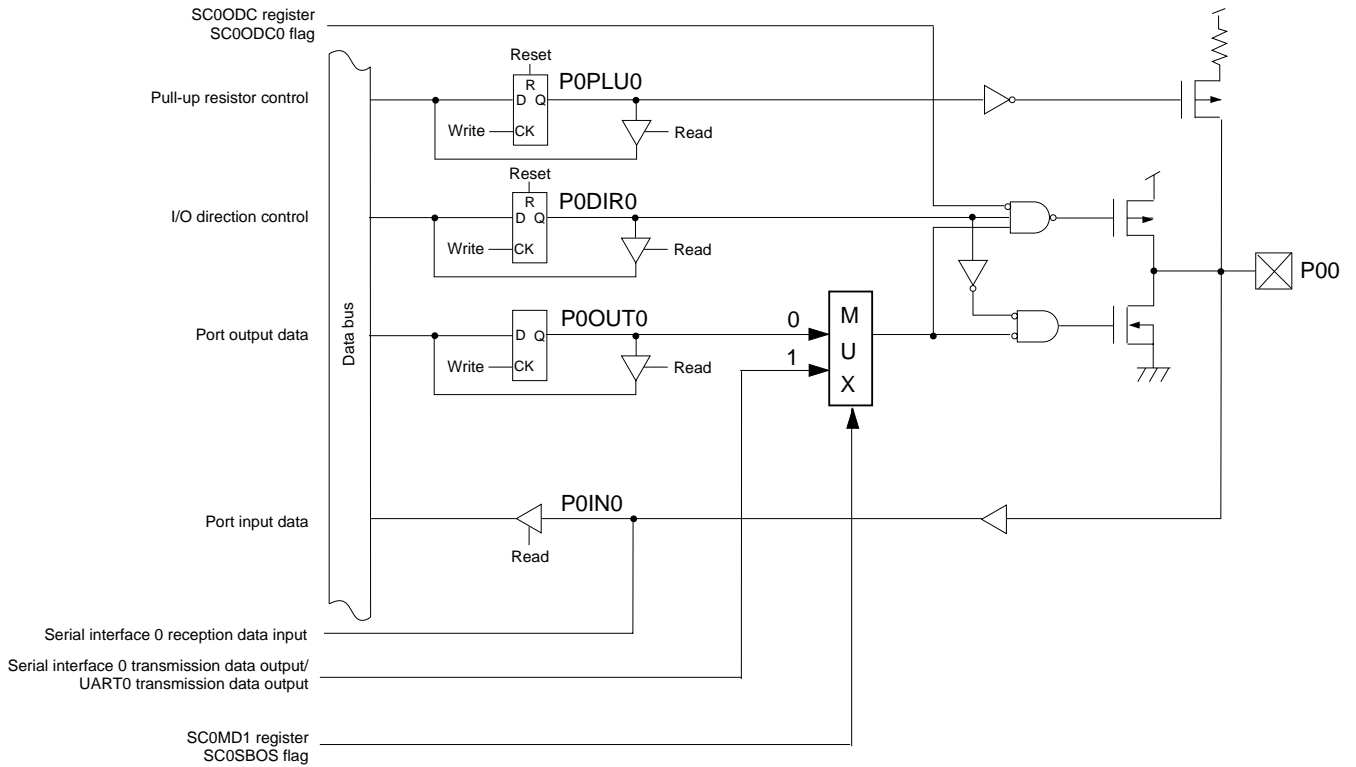


Figure 4-2-2 Block diagram (P00)

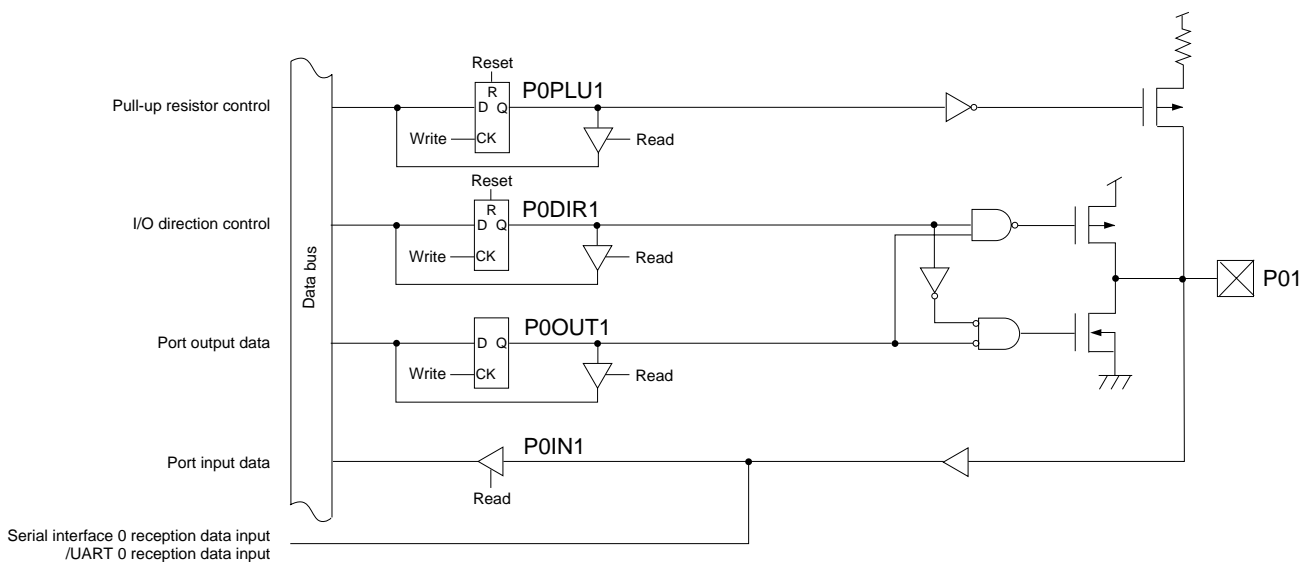


Figure 4-2-3 Block diagram (P01)

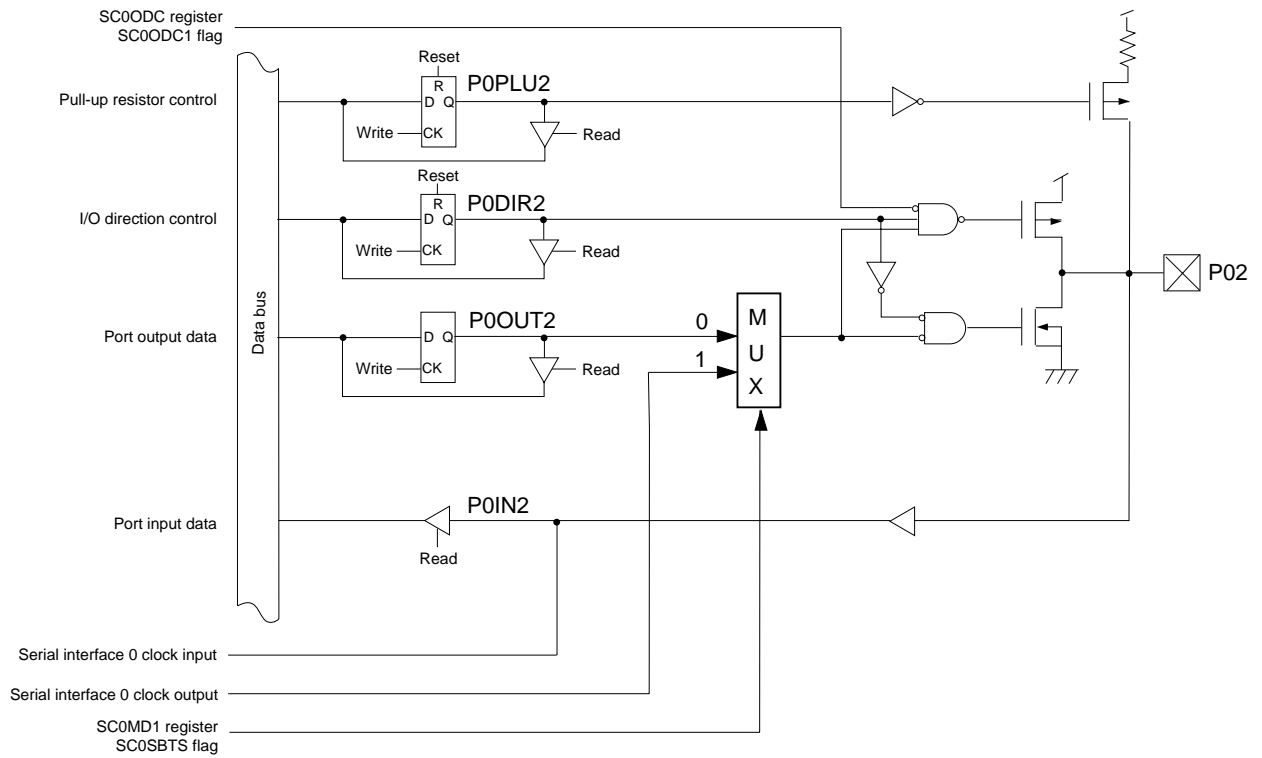


Figure 4-2-4 Block diagram (P02)

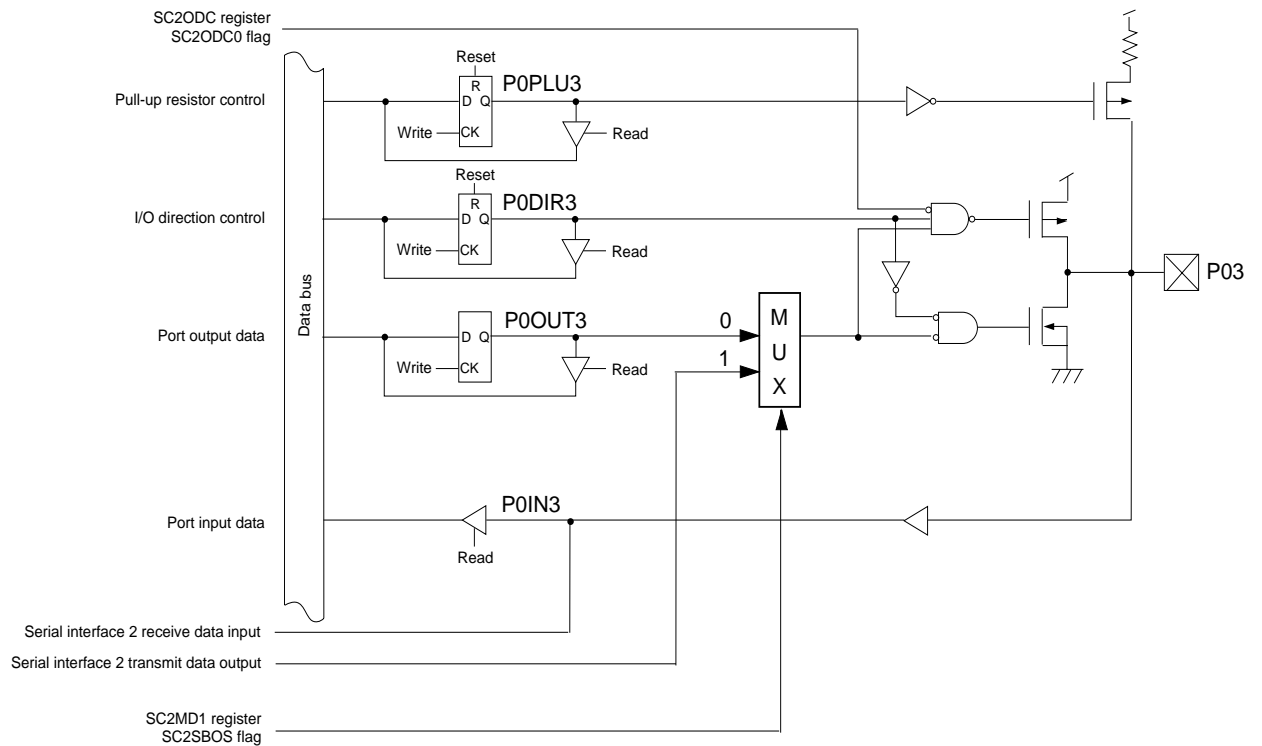


Figure 4-2-5 Block diagram (P03)

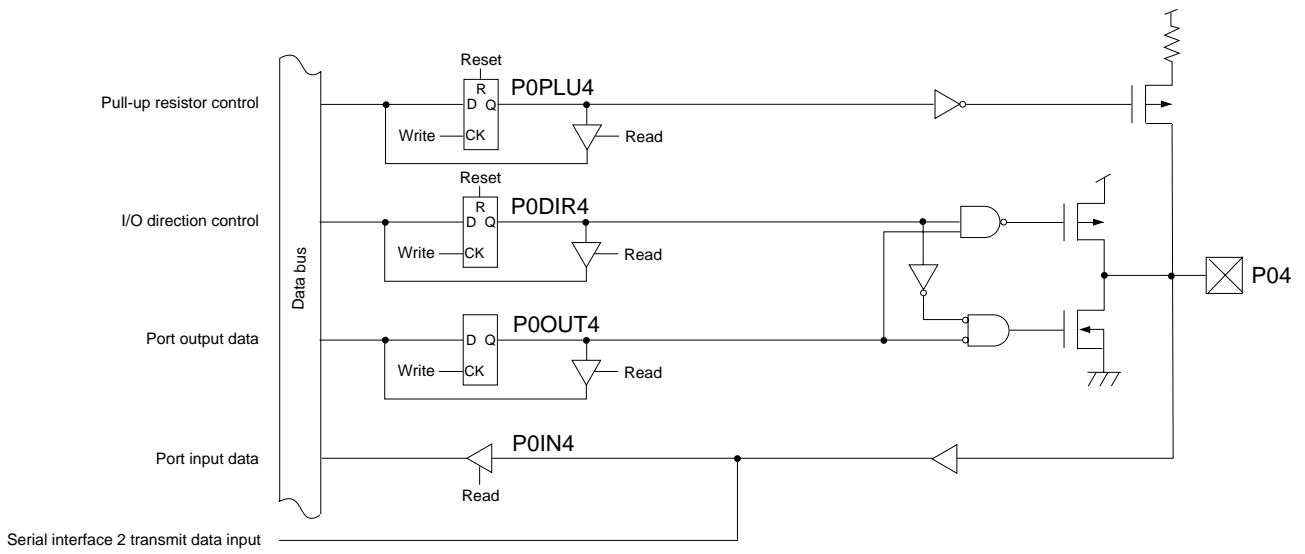


Figure 4-2-6 Block Diagram (P04)

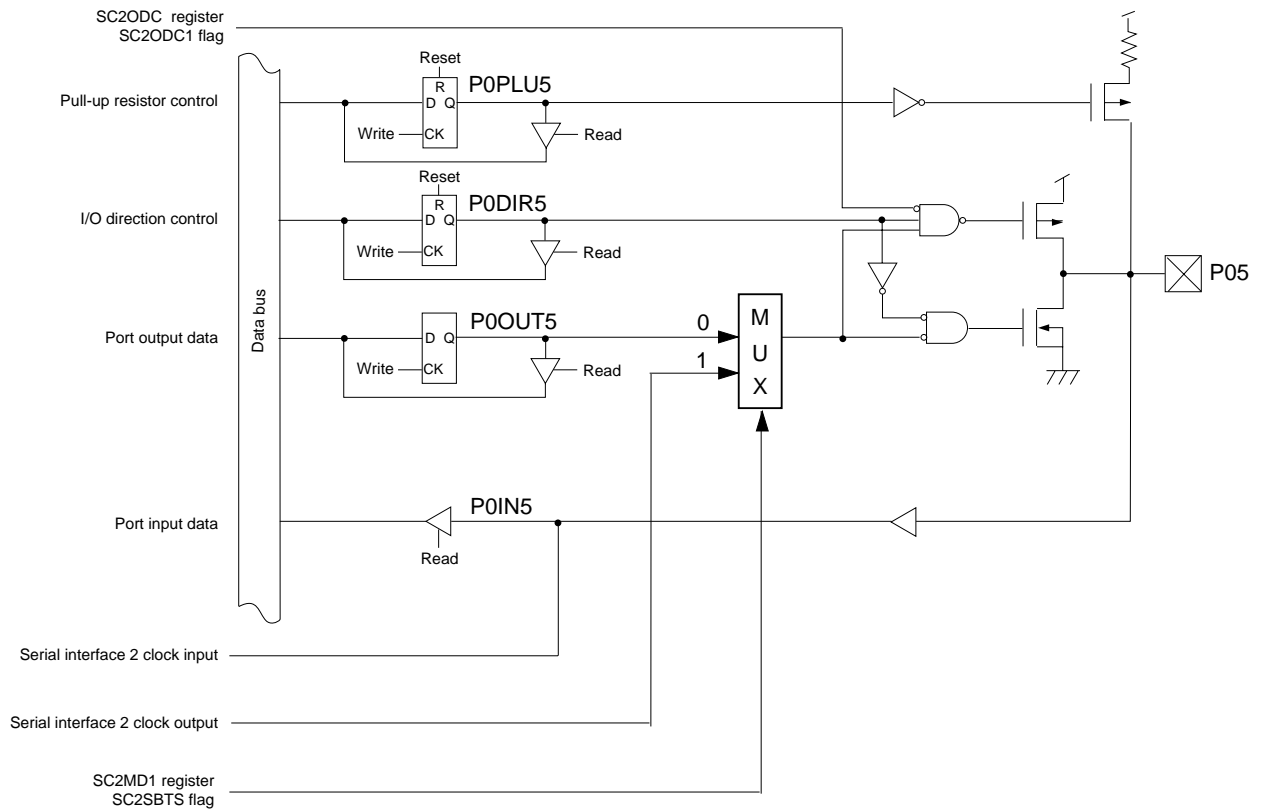


Figure 4-2-7 Block Diagram (P05)

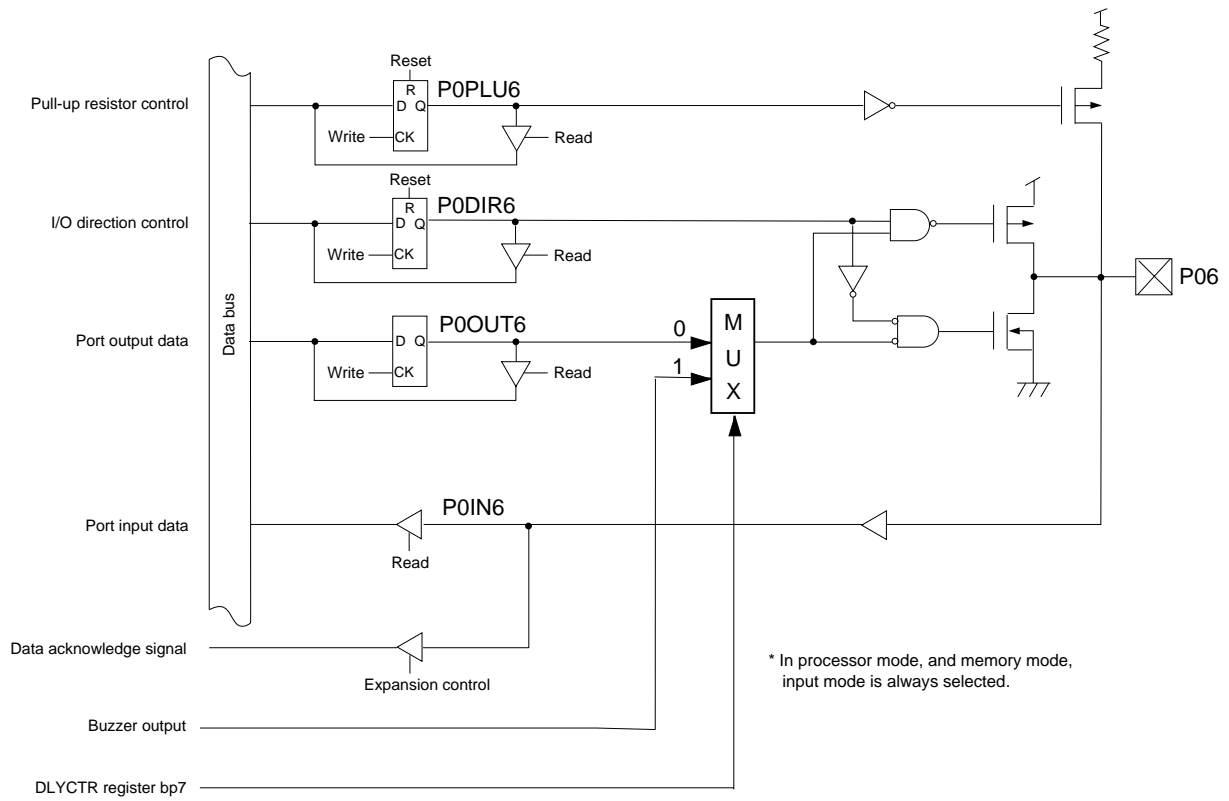


Figure 4-2-8 Block Diagram (P06)

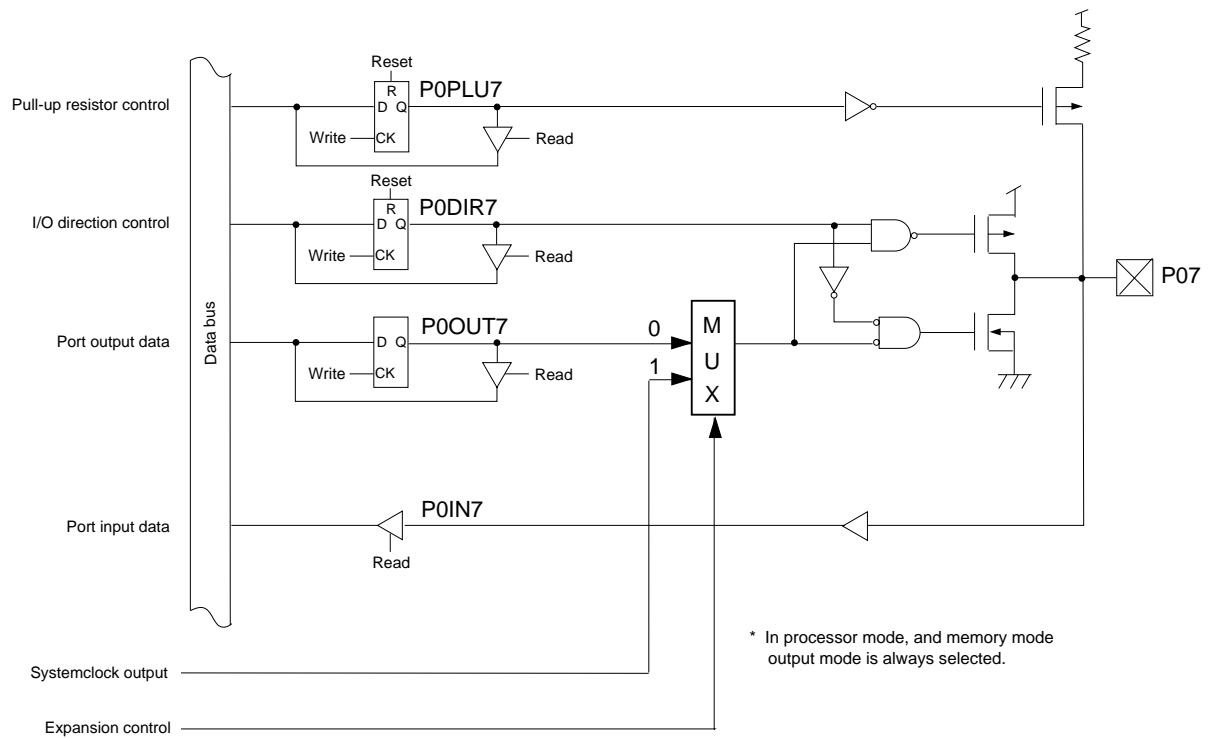


Figure 4-2-9 Block Diagram (P07)

## 4-3 Port 1

### 4-3-1 Description

#### ■General Port Setup

Each bit of the port 1 control I/O direction register (P1DIR) can be set individually to set pins as input or output. The control flag of the port 1 direction control register (P1DIR) should be set to "1" for output mode, and "0" for input mode.

To read input data of pin, set the control flag of the port 1 direction control register (P1DIR) to "0" and read the value of the port 1 input register (P1IN).

To output data to pin, set the control flag of the port 1 direction control register (P1DIR) to "1" and write the value of the port 1 output register (P1OUT).

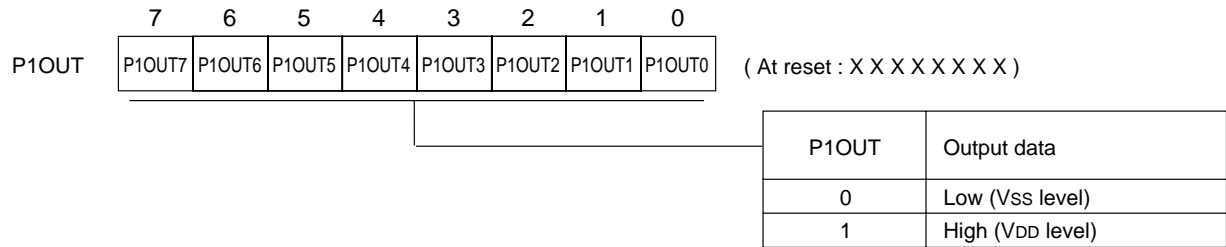
Each pin can be set individually if pull-up resistor is added or not, by the port 1 pull-up resistor control register (P1PLU). Set the control flag of the port 1 pull-up resistor control register (P1PLU) to "1" to add pull-up resistor.

#### ■Special Function Pin Setup

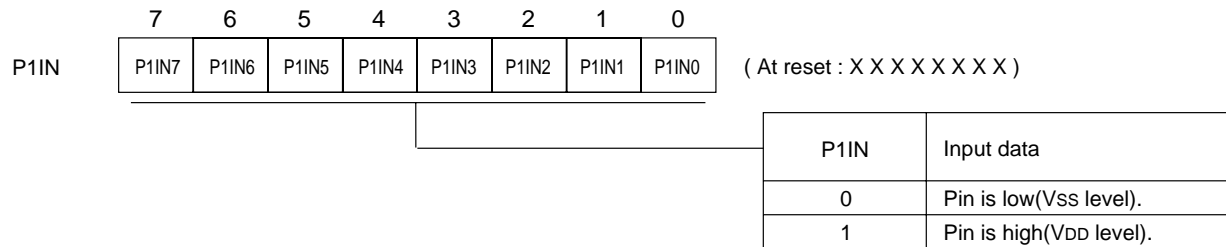
P10 to P14, P16 are used as timer I/O pin, as well. P10 is used as remote control carrier output pin, as well. The port 1 output mode register (P1OMD) can select P10 to P14, P16 output mode by each bit. When the port 1 output mode register (P1OMD) is "1", special function data is output, and when it is "0", they are used as general port.

Also, P10, P12 and P14 has real time output control function. They can switch pin output to 3 type; "0", "1", and "high-impedance state (Hi-z)", in synchronization with the falling edge of the external interrupt 0 pin (P20/IRQ0). Real time control changes the timer output signal (PWM output, timer pulse output, remote control carrier output) in synchronization with external event, without programming software. For more information, refer to 4-14 Real Time Output Control Function [p.IV-56].

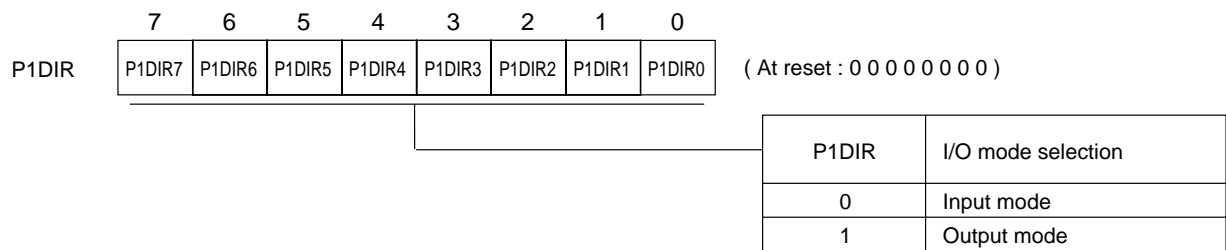
### 4-3-2 Registers



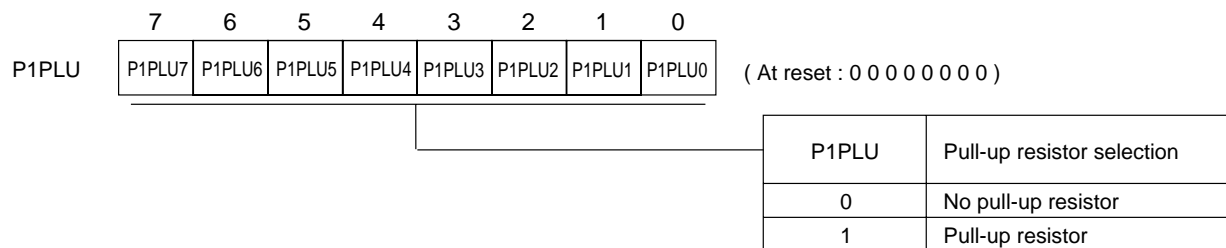
Port 1 output register (P1OUT : x'03F11', R/W)



Port 1 input register (P1IN : x'03F21', R)

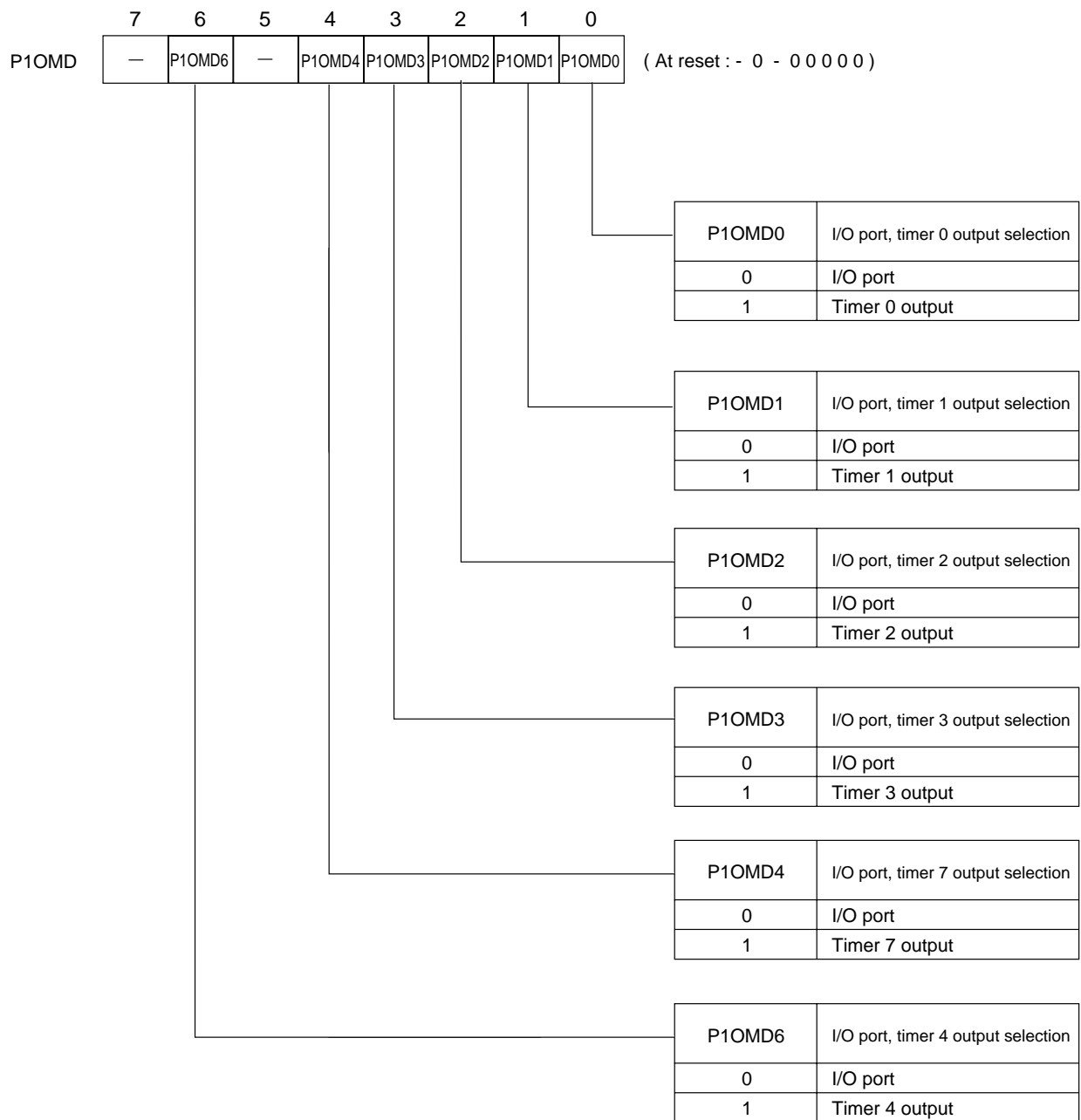


Port 1 direction control register (P1DIR : x'03F31', R/W)



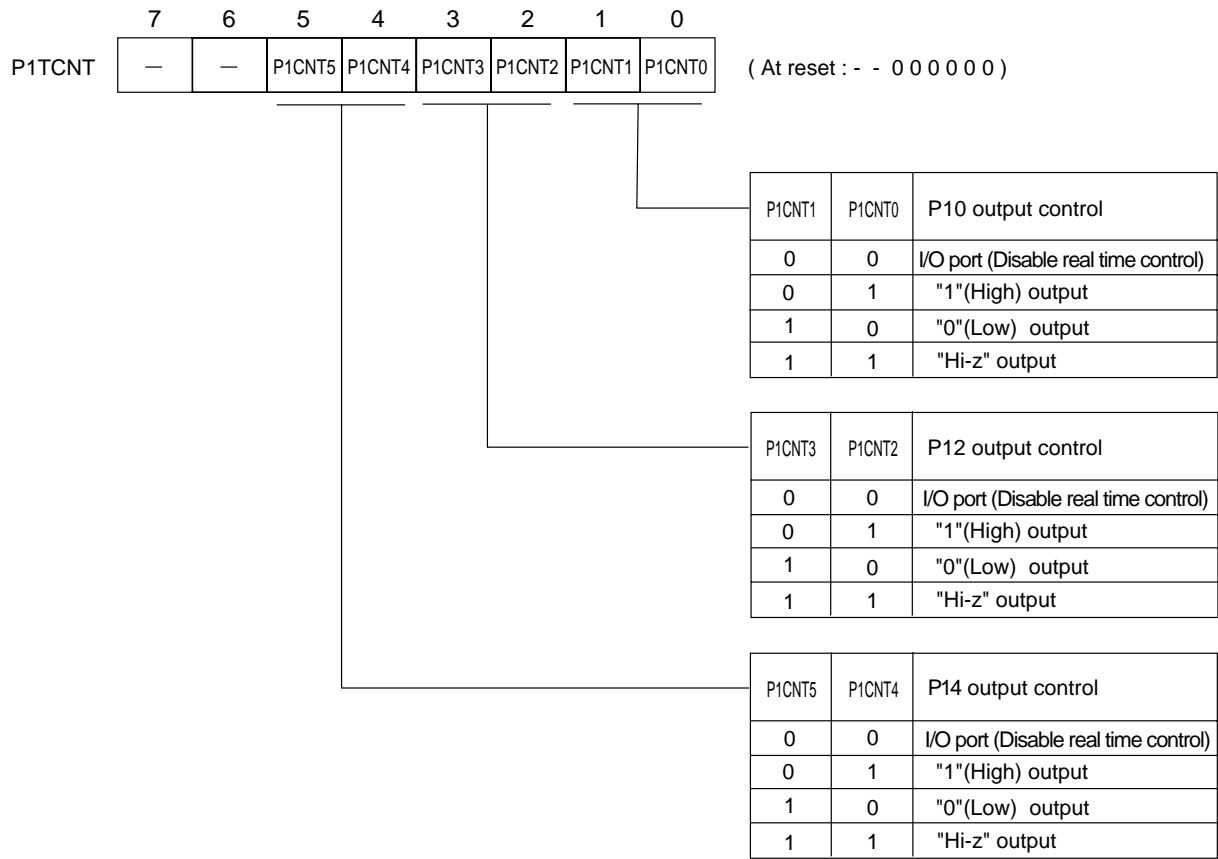
Port 1 pull-up resistor control register (P1PLU : x'03F41', R/W)

**Figure 4-3-1 Port 1 Registers (1/3)**



Port 1 output mode register (P1OMD : x'03F2F', R/W)

Figure 4-3-1 Port 1 Registers (2/3)



Port 1 output control register (P1TCNT : x'03F7E', R/W)

Figure 4-3-3 Port 1 Registers (3/3)



### 4-3-3 Block Diagram

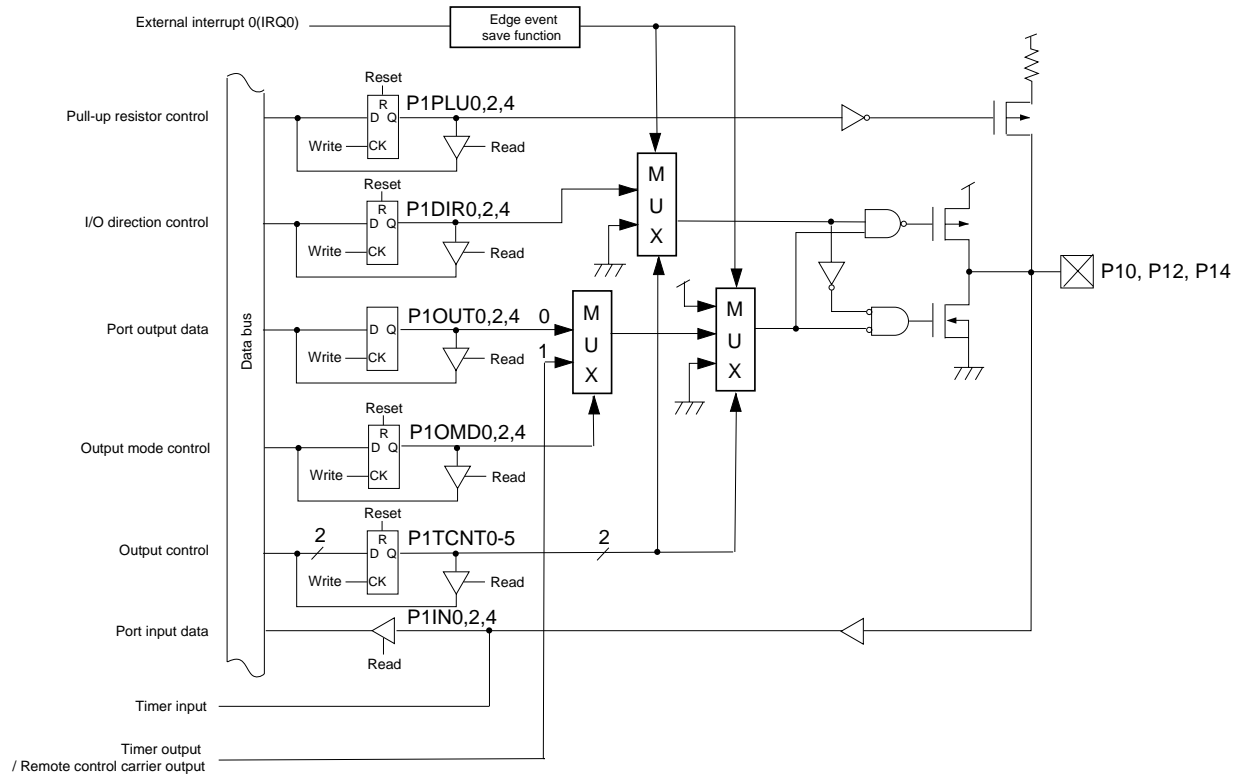


Figure 4-3-4 Block Diagram (P10, P12, P14)

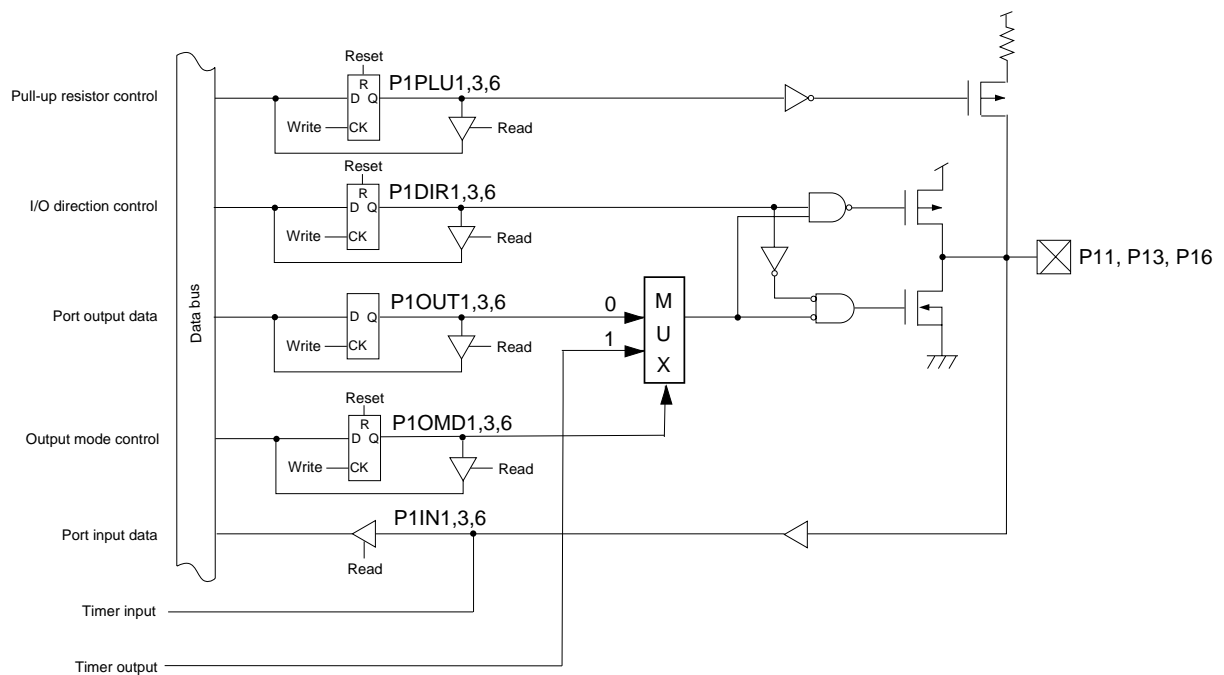


Figure 4-3-5 Block Diagram (P11, P13, P16)

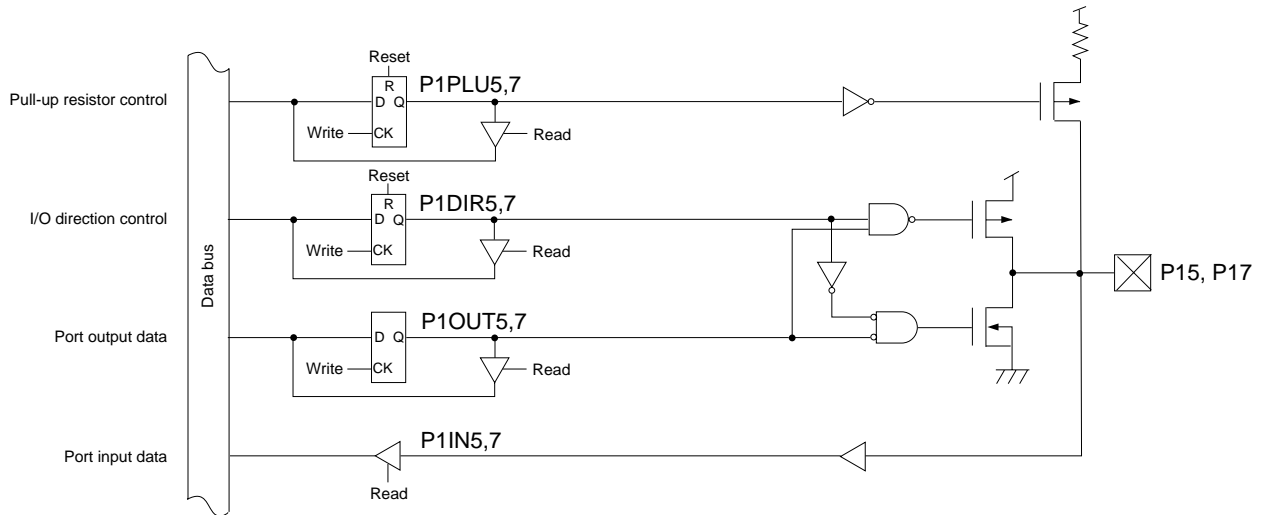


Figure 4-3-6 Block Diagram (P15, P17)

## 4-4 Port 2

### 4-4-1 Description

#### ■General Port Setup

Port 2 is input port, except P27. To read input data of pin, read out the value of the port 2 input register (P2IN).

P27 is reset pin. When the software is reset, write the bp7 of the port 2 output register (P2OUT) to "0".

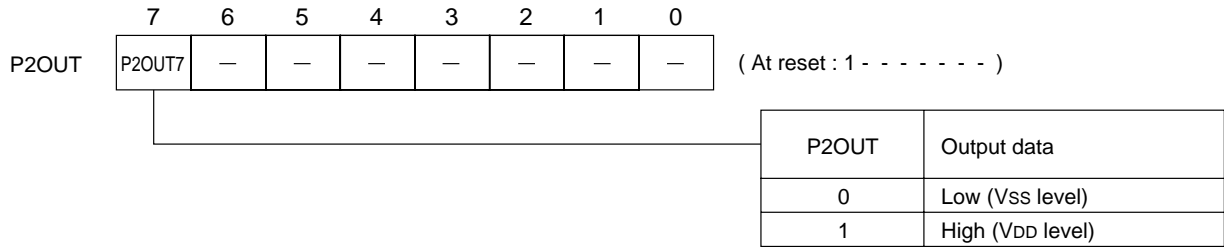
The port 2 pull-up resistor control register (P2PLU) can select if port 2 is added pull-up resistor or not, by each bit. When the control flag of the port 2 pull-up resistor control register (P2PLU) is set to "1", pull-up resistor is added. P27 is always added pull-up resistor.

#### ■Special Function Pin Setup

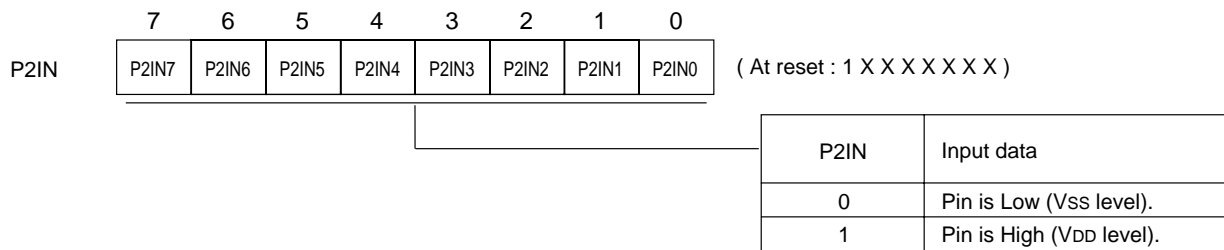
P20, P22 to P25 are used as external interrupt pins, as well.

P21 is used as an input pin for external interrupt and AC zero-cross. To read data of AC zero-cross, set the bp7 of the noise filter control register (NFCTR) to "1" and read the value of the port 2 input register (P2IN).

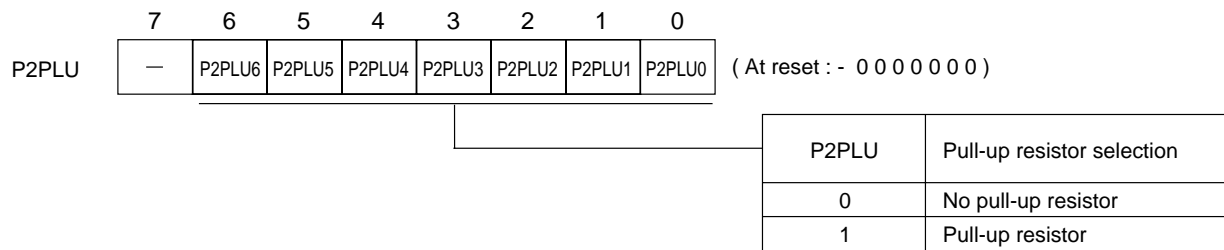
### 4-4-2 Registers



Port 2 output register(P2OUT : x'03F12', R/W)



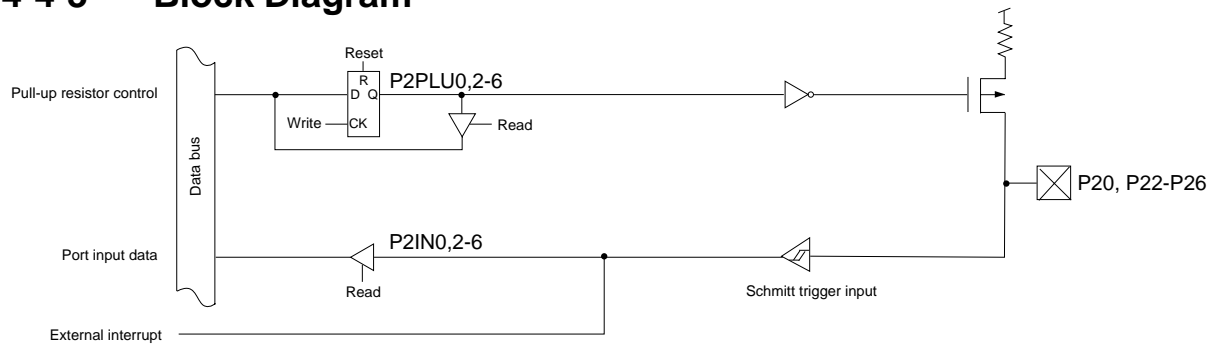
Port 2 input register(P2IN : x'03F22', R)



Port 2 pull-up resistor control register(P2PLU : x'03F42', R/W)

**Figure 4-4-1 Port 2 Registers**

### 4-4-3 Block Diagram



P26 is not used as an external interrupt pin

\*

Figure 4-4-2 Block Diagram (P20, P22 to P26)

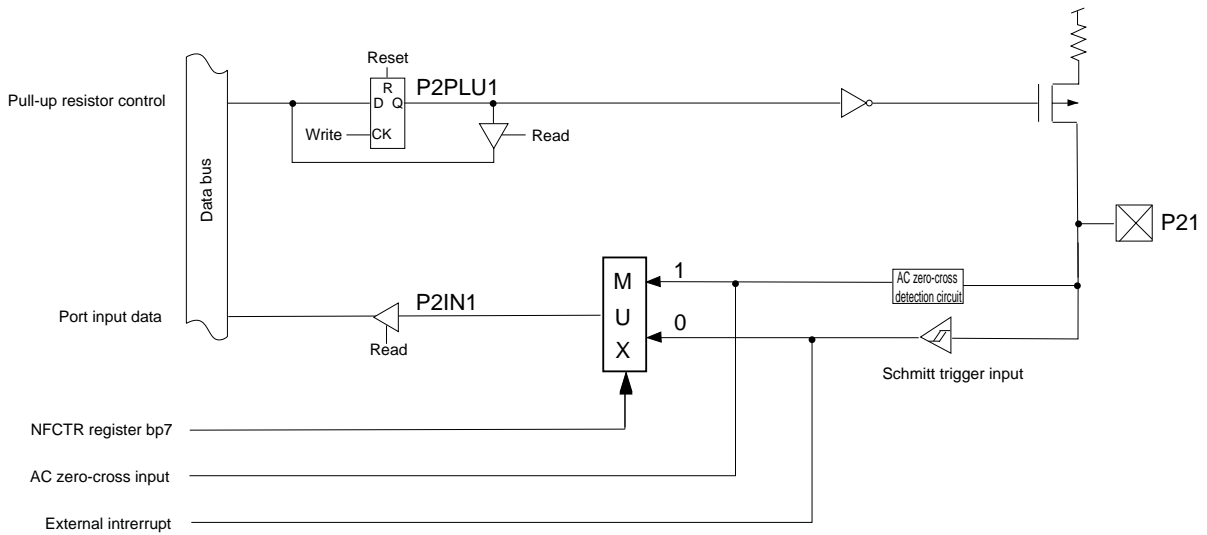


Figure 4-4-3 Block Diagram (P21)

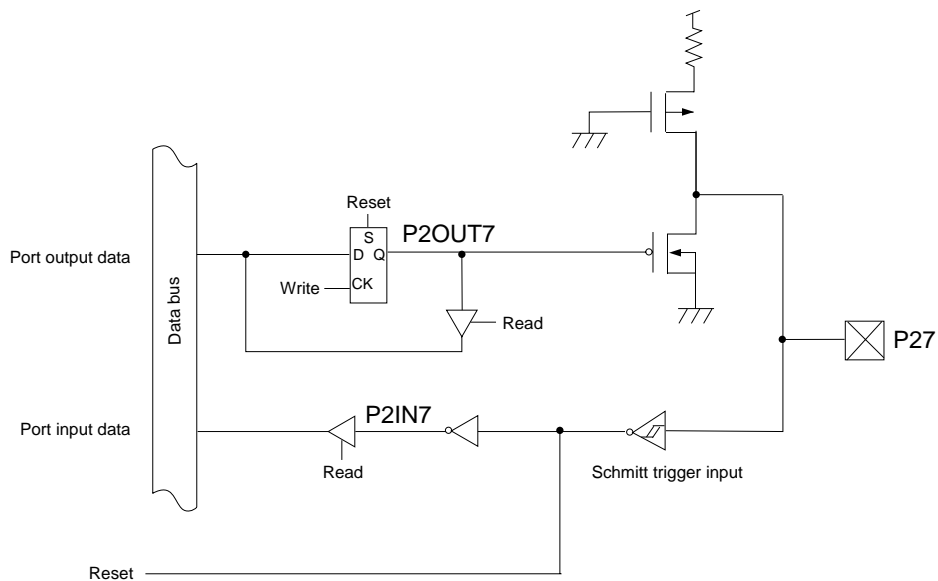


Figure 4-4-4 Block Diagram (P27)

## 4-5 Port 3

### 4-5-1 Description

#### ■General Port Setup


Each bit of the port 3 control I/O direction register (P3DIR) can be set individually to set pins as input or output. The control flag of the port 3 direction control register (P3DIR) is set to "1" for output mode, and "0" for input mode.

To read input data of pin, set the control flag of the port 3 direction control register (P3DIR) to "0" and read the value of the port 3 input register (P3IN).


To output data to pin, set the control flag of the port 3 direction control register (P3DIR) to "1" and write the value of the port 3 output register (P3OUT).

Each pin can be set individually if pull-up resistor is added or not, by the port 3 pull-up resistor control register (P3PLU). Set the control flag of the port 3 pull-up resistor control register (P3PLU) to "1" to add pull-up resistor.

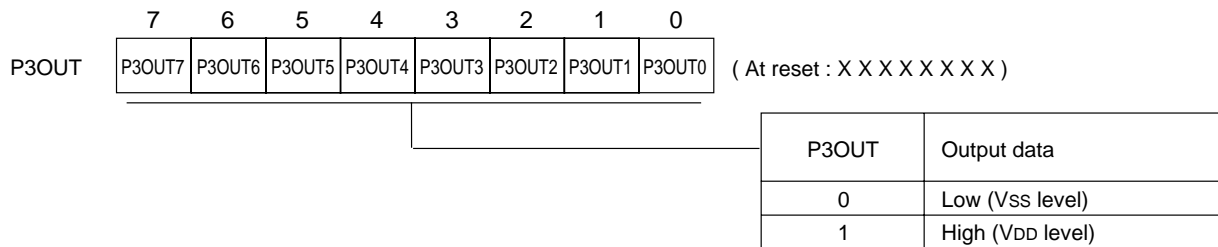
#### ■Special Function Pin Setup

P30 to P32 are used as serial interface 1 I/O pins, as well. P30 is an output pin for serial interface 1 transmission data and UART 1 transmission data. When the SC1SBOS flag of the serial interface 1 mode register 1 (SC1MD1) is set to "1", serial data output pin is selected. P31 is an input pin for serial 1 received data and UART 1 received data. P32 is a serial interface 1 clock I/O pin. When the SC1SBTS flag of the serial interface 1 mode register 1 (SC1MD1) is set to "1", serial clock output pin is selected. P30 and P32 can be selected as either an push-pull output of Nch open-drain output by the serial interface 1 port control register (SC1ODC). [  Chapter 12 12-2. Control registers ]

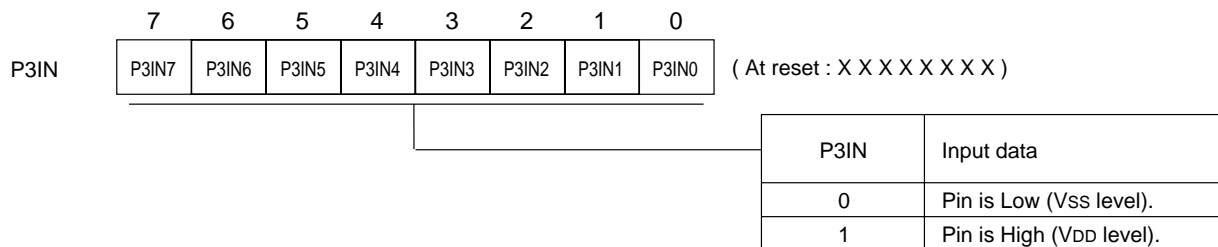
P33 to P35 are used as I/O pins for serial interface 3 and external DMA, as well. P33 is an output pin for serial interface 3 transmission data and an input pin for bus release request. When the SC2SBOS flag of the serial interface interface 3 mode register 1 (SC3MD1) is set to "1", serial data output pin is selected. P34 is an output pin for bus use approval signal and an output pin for serial interface 3 received data. When the ATEXT flag of the ATC1 control register 0 (AT1CNT0) is set to "1", bus use approval signal output pin is selected. P35 is an I/O pin for serial interface 3 clock and an input pin for external DMA load request signal. When the SC3SBTS flag of the serial interface 3 mode register 1 (SC3MD1) is set to "1", serial clock output pin is selected.

P33 and P35 can be selected as either an push-pull output of Nch open-drain output by the serial interface 3 port control register (SC3ODC). [  Chapter 14 14-2. Control registers ]

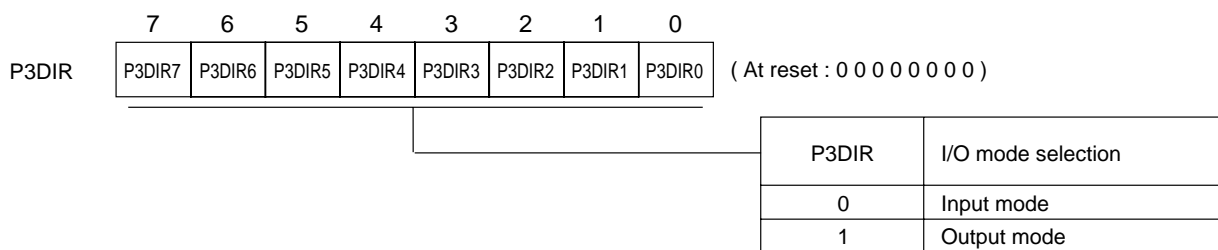
## 4-5-2 Registers



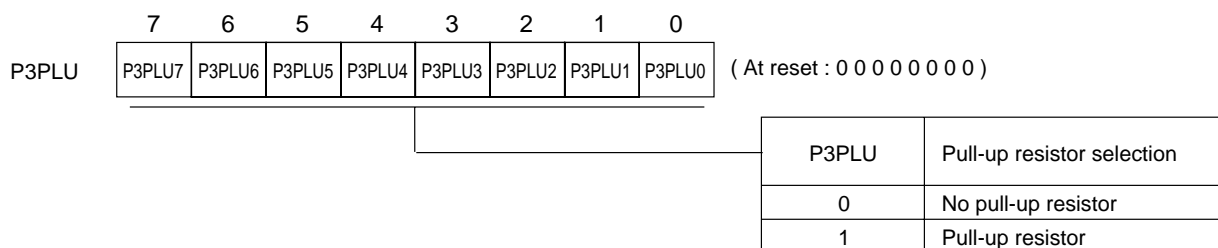
Port 3 output register (P3OUT : x'03F13', R/W)



Port 3 input register (P3IN : x'03F23', R)



Port 3 direction control register (P3DIR : x'03F33', R/W)



Port 3 pull-up resistor control register (P3PLU : x'03F43', R/W)

Figure 4-5-1 Port 3 Registers

### 4-5-3 Block Diagram

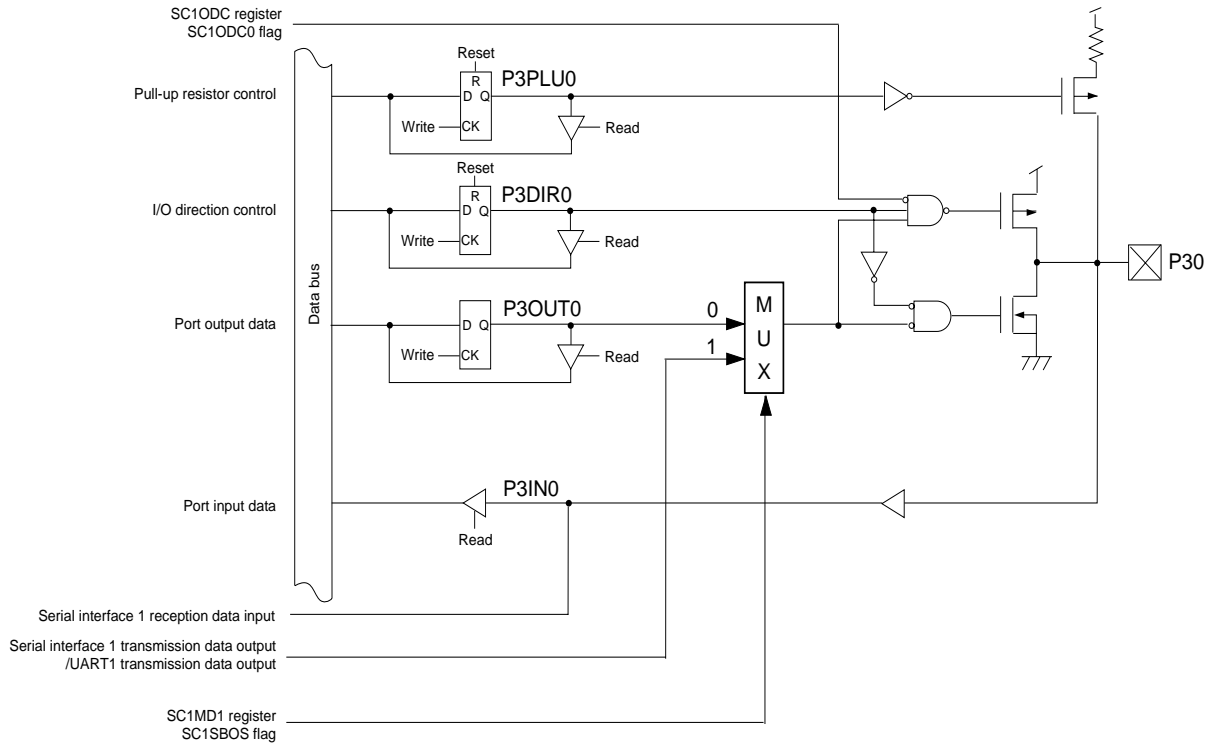


Figure 4-5-2 Block Diagram (P30)

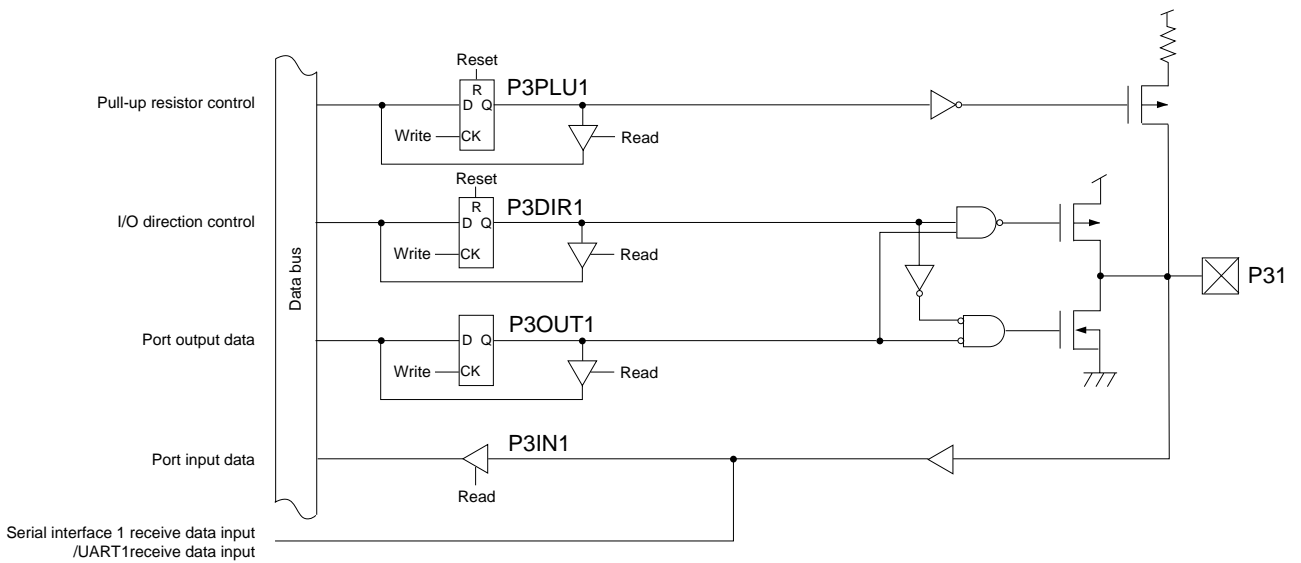


Figure 4-5-3 Block Diagram (P31)



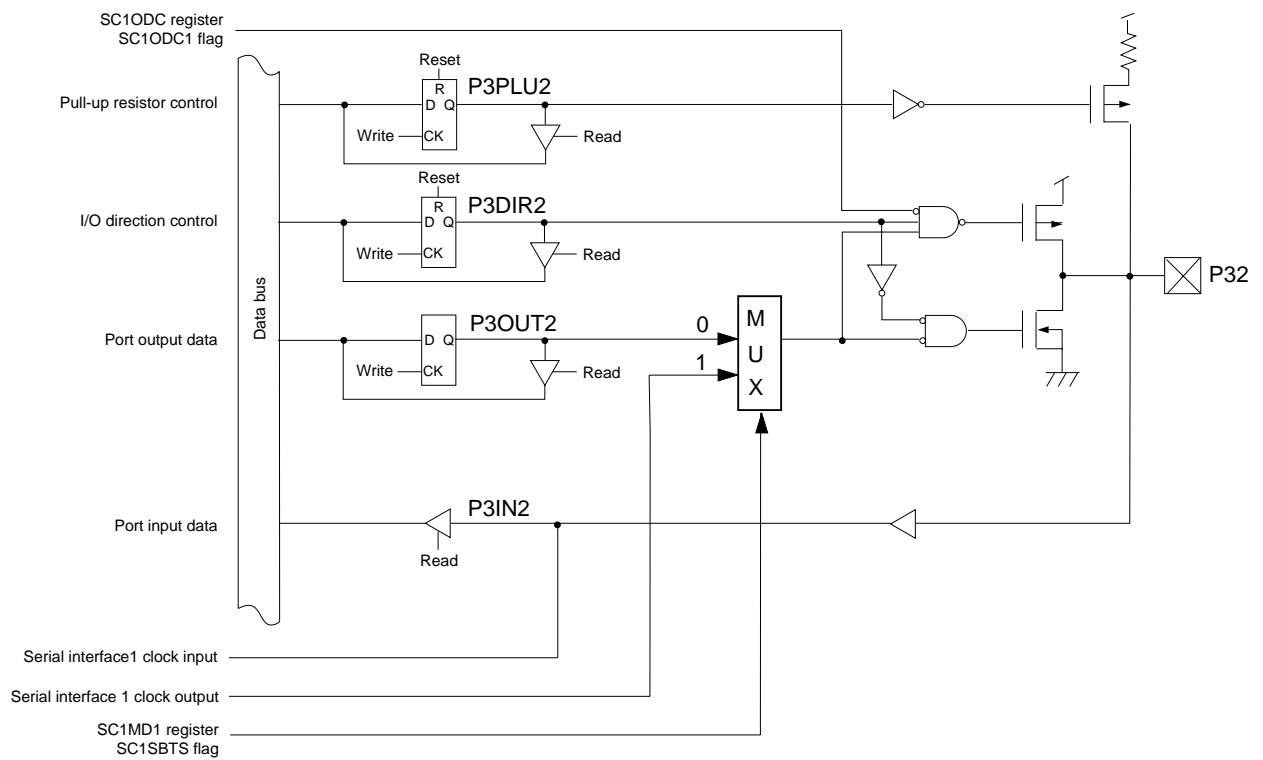


Figure 4-5-4 Block Diagram (P32)

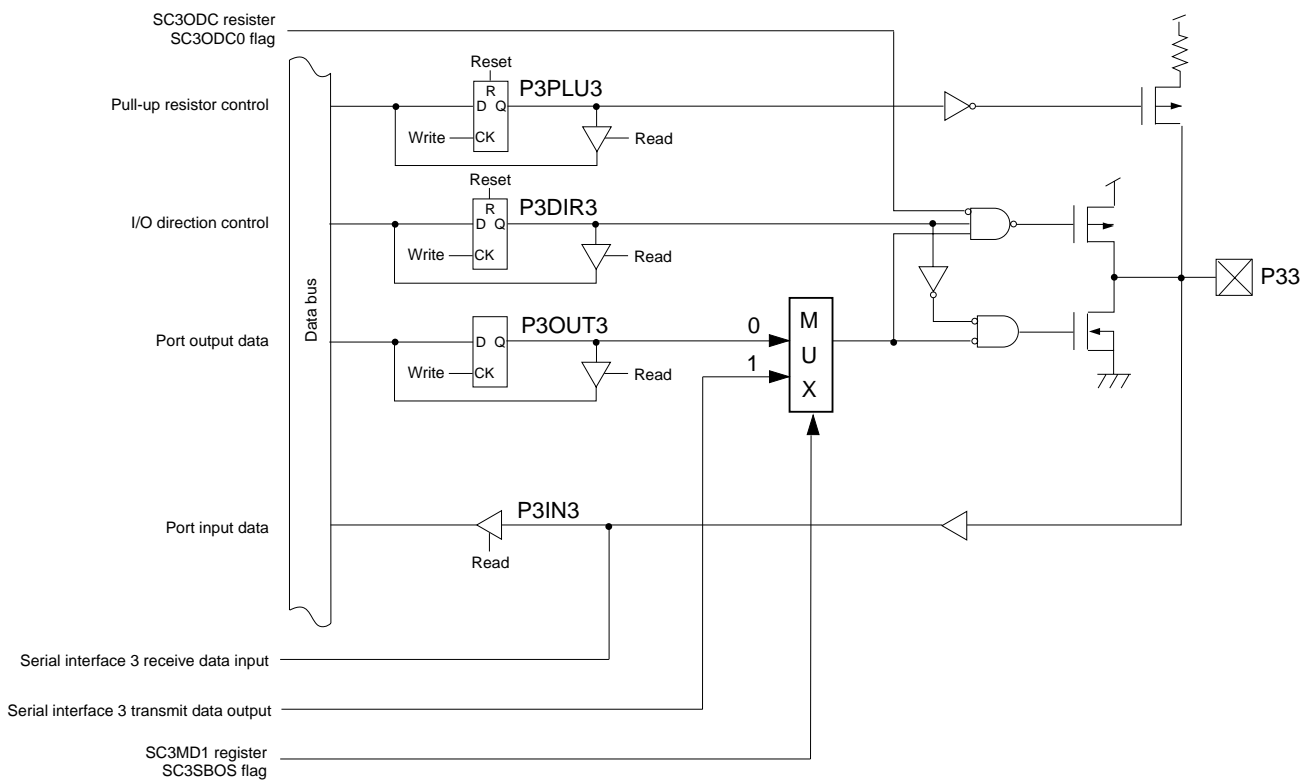


Figure 4-5-5 Block Diagram (P33)

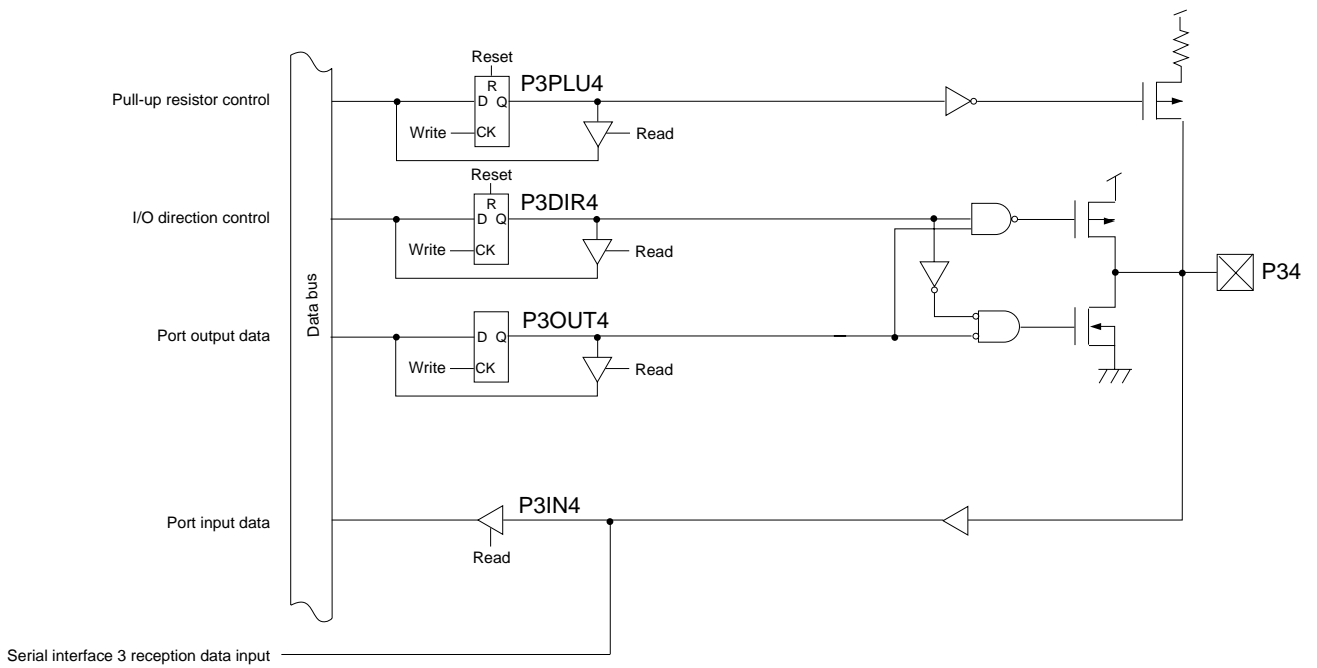


Figure 4-5-6 Block Diagram (P34)

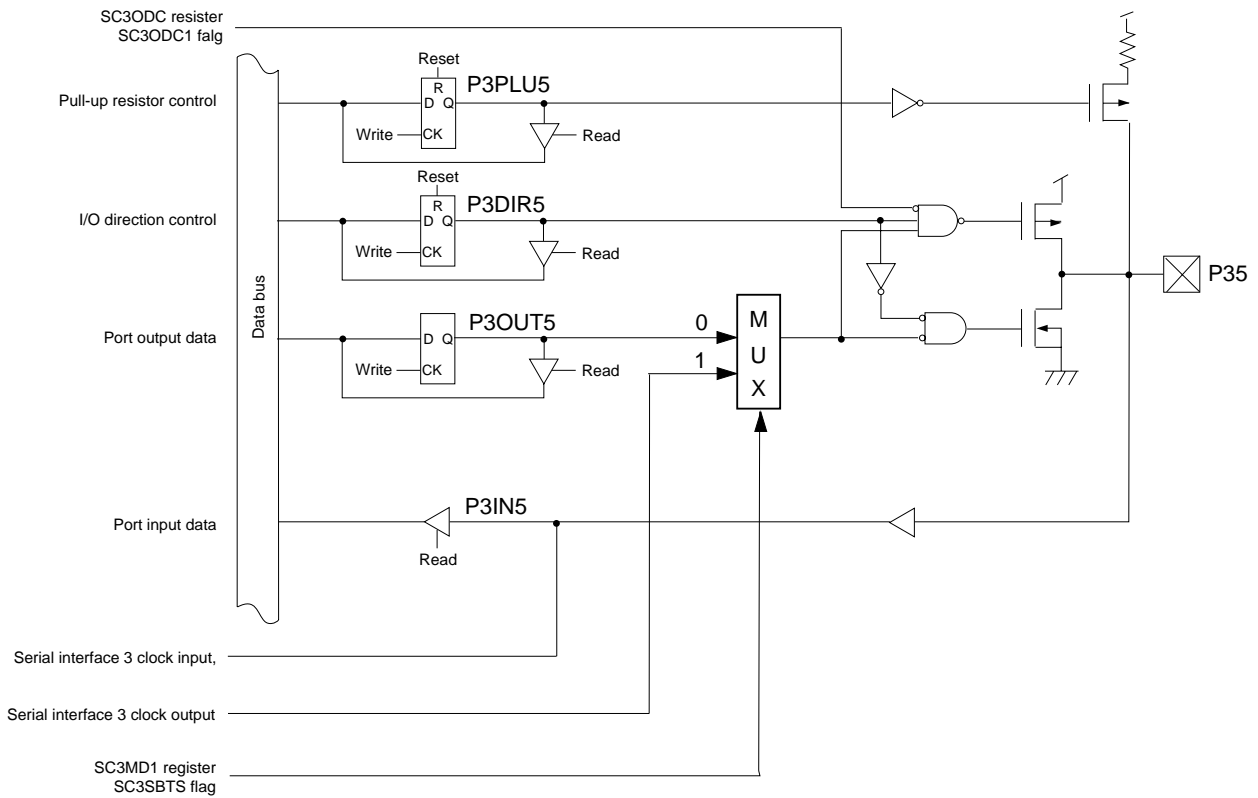


Figure 4-5-7 Block Diagram (P35)

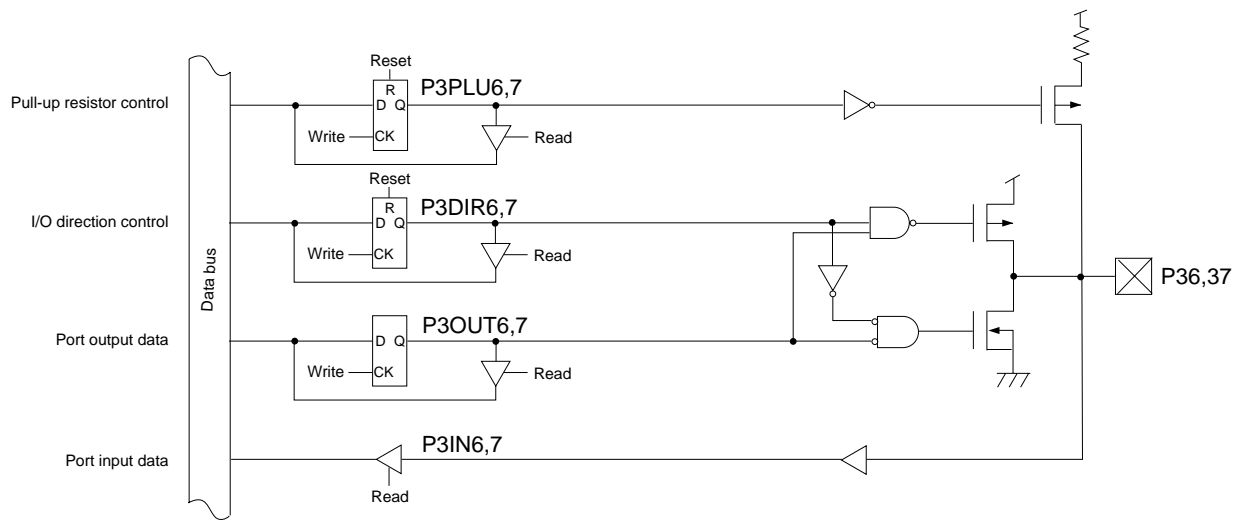


Figure 4-5-8 Block Diagram (P36,37)

## 4-6 Port 4

### 4-6-1 Description

#### ■General Port Setup

Each bit of the port 4 control I/O direction register (P4DIR) can be set individually to set pins as input or output. The control flag of the port 4 direction control register (P4DIR) is set to "1" for output mode, and "0" for input mode.

To read input data of pin, set the control flag of the port 4 direction control register (P4DIR) to "0" and read the value of the port 4 input register (P4IN).

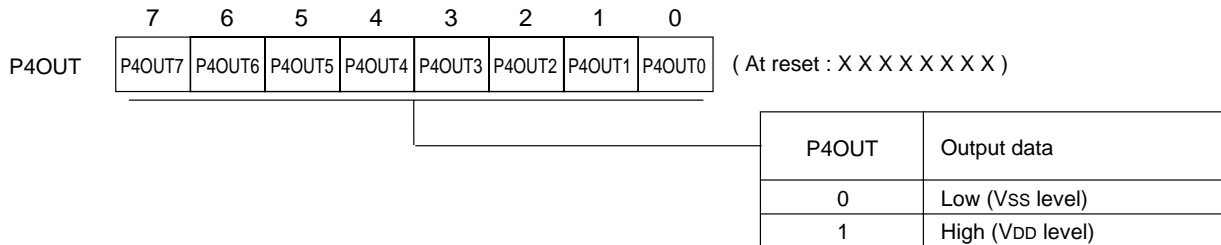
To output data to pin, set the control flag of the port 4 direction control register (P4DIR) to "1" and write the value of the port 4 output register (P4OUT).

Each pin can be set individually if pull-up / pull-down resistor is added or not, by the port 4 pull-up / pull-down resistor control register (P4PLUD). Set the control flag of the port 4 pull-up / pull-down resistor control register (P4PLUD) to "1" to add pull-up or pull-down resistor. The pull-up / pull-down resistor selection register (FLOAT) select if pull-up resistor or pull-down resistor is added. The bp3 of the pull-up / pull-down resistor control register (FLOAT) is set to "1" for pull-down resistor, set to "0" for pull-up resistor.

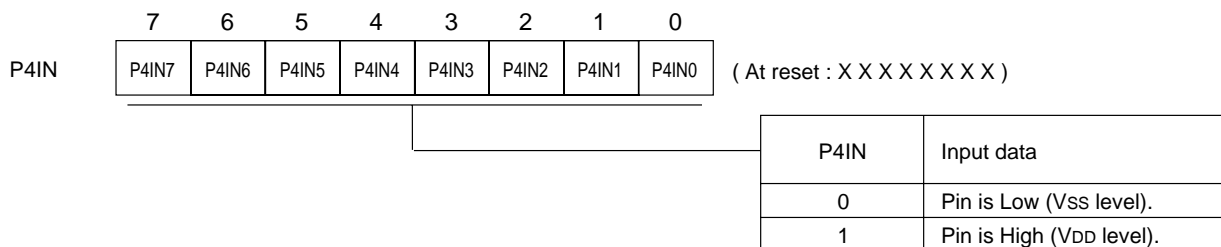
#### ■Special Function Pin Setup

P40 to P47 are used as input pins for KEY interrupt.

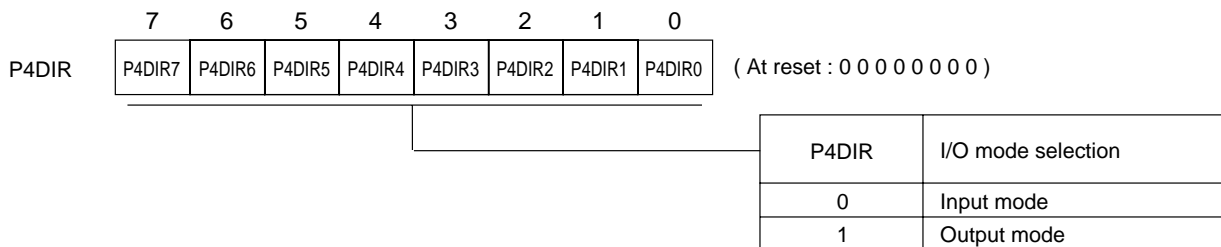
## 4-6-2 Registers



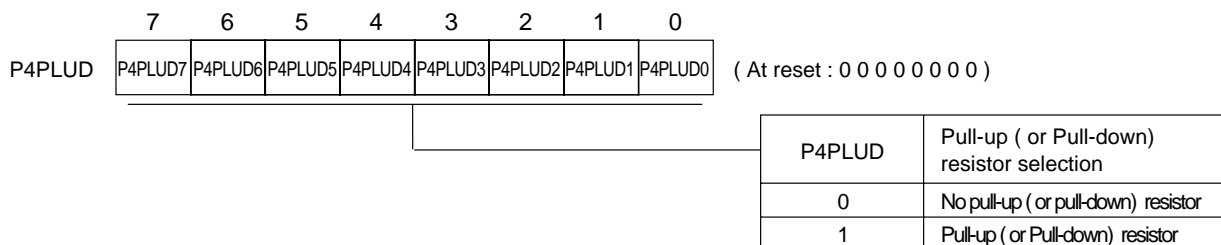
Port 4 output register (P4OUT : x'03F14', R/W)



Port 4 input register (P4IN : x'03F24', R)

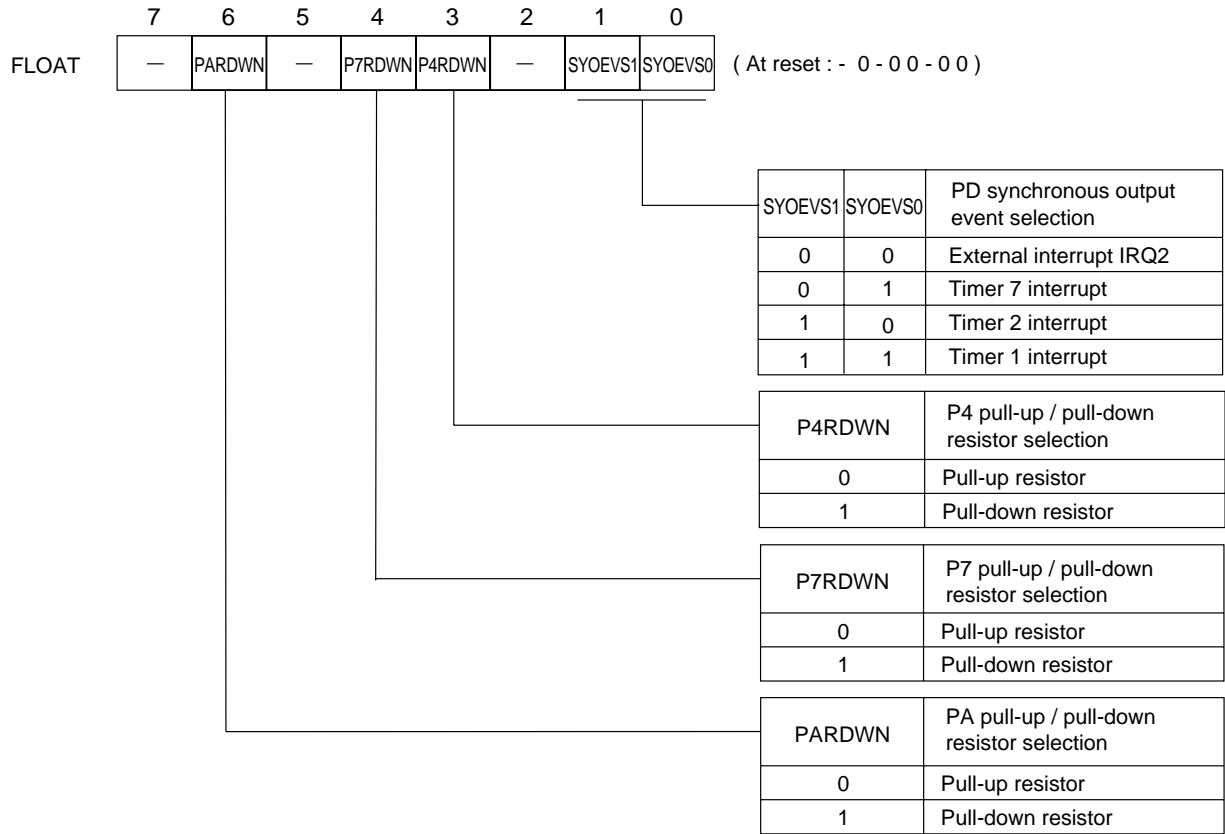


Port 4 direction control register (P4DIR : x'03F34', R/W)



Port 4 pull-up / pull-down resistor control register (P4PLUD : x'03F44', R/W)

Figure 4-6-1 Port 4 Registers (1/2)



Pull-up / Pull-down resistor selection, Pin control register (FLOAT : x'03F2E', R/W)

**Figure 4-6-2 Port 4 Registers (2/2)**

### 4-6-3 Block Diagram

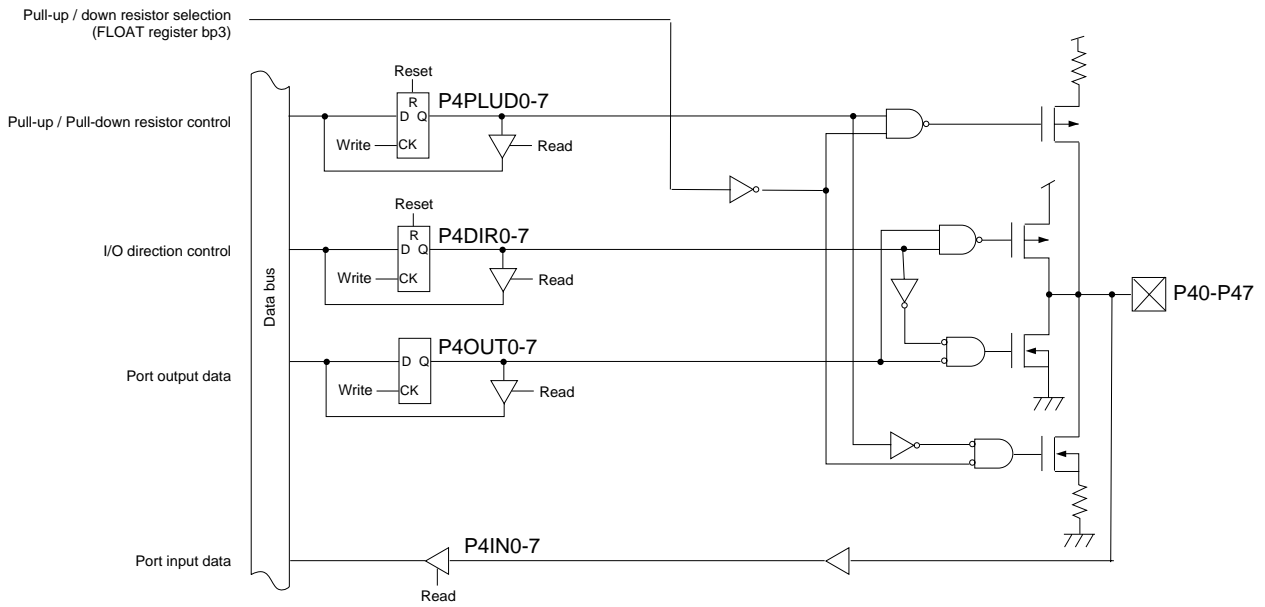


Figure 4-6-3 Block Diagram (P40 to P47)

## 4-7 Port 5

### 4-7-1 Description

#### ■General Port Setup

Each bit of the port 5 control I/O direction register (P5DIR) can be set individually to set pins as input or output. The control flag of the port 5 direction control register (P5DIR) is set to "1" for output mode, and "0" for input mode.

To read input data of pin, set the control flag of the port 5 direction control register (P5DIR) to "0" and read the value of the port 5 input register (P5IN).

To output data to pin, set the control flag of the port 5 direction control register (P5DIR) to "1" and write the value of the port 5 output register (P5OUT).

Each pin can be set individually if pull-up resistor is added or not, by the port 5 pull-up resistor control register (P5PLU). Set the control flag of the port 5 pull-up resistor control register (P5PLU) to "1" to add pull-up resistor.

#### ■Special Function Pin Setup

In processor mode or memory expansion mode, P50 to P52 are output pins for control signal to the expansion memory. In those mode, output mode is always selected.

In processor mode or memory expansion mode, P53 and P54 are output pins for address to the expansion memory. But in memory expansion mode, the bp7 of the address output control register (EXADV) set if they are used as address output pins or general I/O pins.

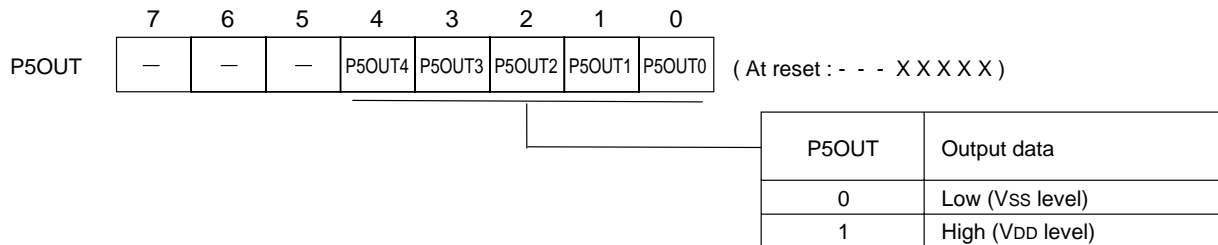
**Table 4-7-1 Expansion Pins (P50 to P54)**

Pins	In processor mode In memory expansion mode *
P50	NWE
P51	NRE
P52	NCS
P53	A16 (External memory address bp16)
P54	A17 (External memory address bp17)

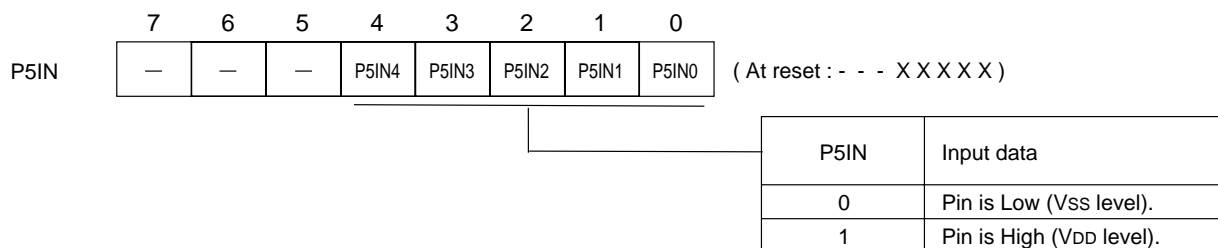
\* In memory expansion mode, the bp 7 of the EXADV register should be set to "1" for P53,54 output address.



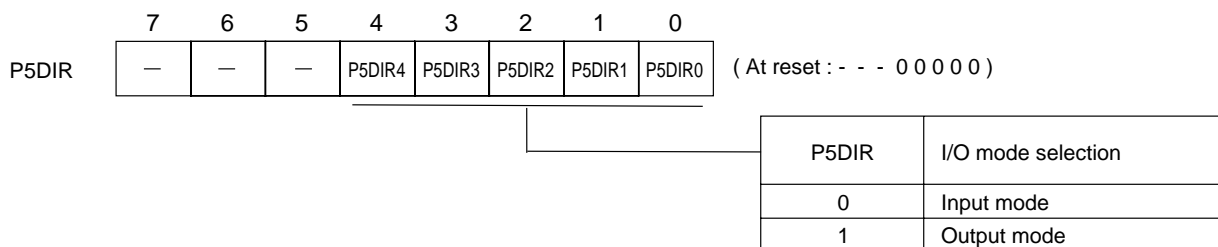
### 4-7-2 Registers



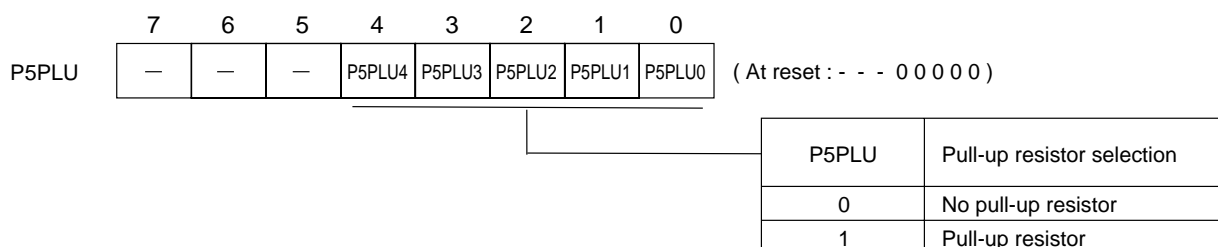
Port 5 output register (P5OUT : x'03F15', R/W)



Port 5 input register (P5IN : x'03F25', R)



Port 5 direction control register (P5DIR : x'03F35', R/W)



Port 5 pull-up resistor control register (P5PLU : x'03F45', R/W)

Figure 4-7-1 Port 5 Registers (1/2)

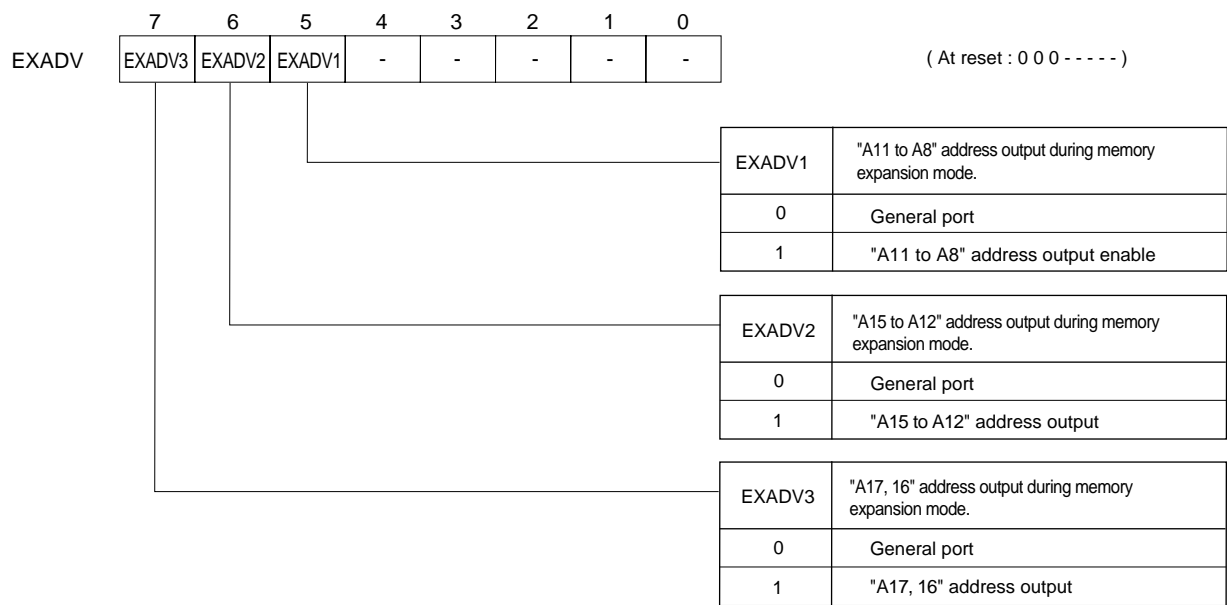


Figure 4-7-2 Port 5 Registers (2/2)

### 4-7-3 Block Diagram

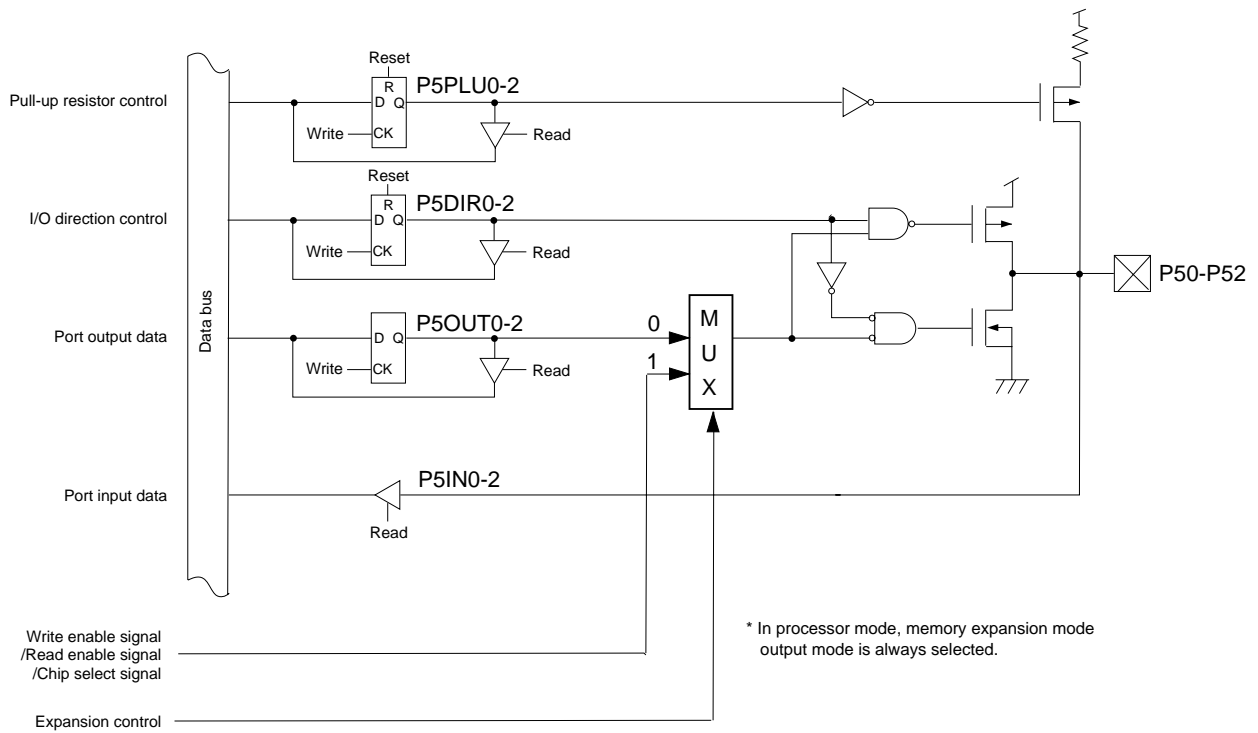


Figure 4-7-3 Block Diagram (P50 to P52)

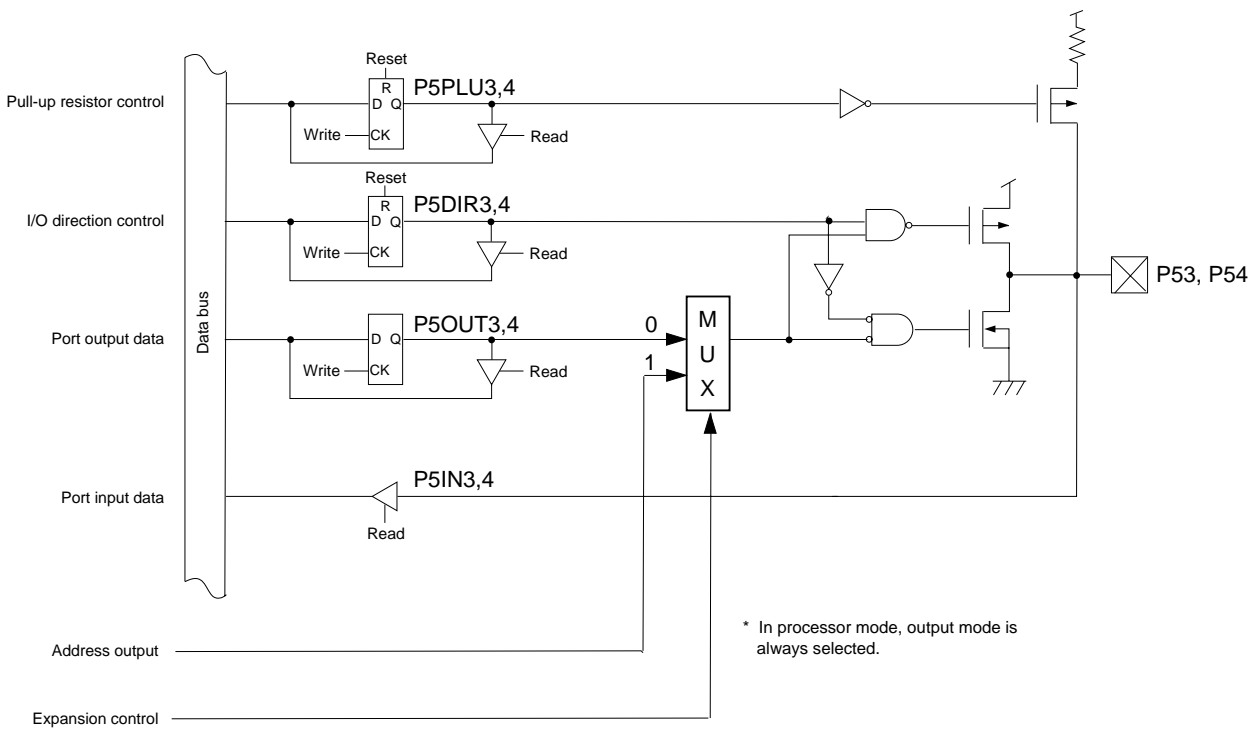


Figure 4-7-4 Block Diagram (P53, P54)

## 4-8 Port 6

### 4-8-1 Description

#### ■General port Setup

Each bit of the port 6 control I/O direction register (P6DIR) can be set individually to set pins as input or output. The control flag of the port 6 direction control register (P6DIR) is set to "1" for output mode, and "0" for input mode.

To read input data of pin, set the control flag of the port 6 direction control register (P6DIR) to "0" and read the value of the port 6 input register (P6IN).

To output data to pin, set the control flag of the port 6 direction control register (P6DIR) to "1" and write the value of the port 6 output register (P6OUT).

Each pin can be set individually if pull-up resistor is added or not, by the port 6 pull-up resistor control register (P6PLU). Set the control flag of the port 6 pull-up resistor control register (P6PLU) to "1" to add pull-up resistor.

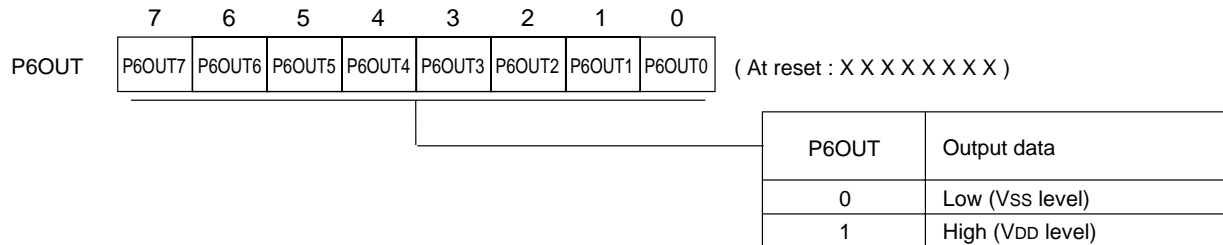
#### ■Special Function Pin Setup

In processor mode or memory expansion mode, P60 to P67 are output pins to the expansion memory. In those mode, any register cannot control input or output. Only at access to the expansion memory, address is output, and during other period (at NCS = "H") it is high impedance state (input mode).

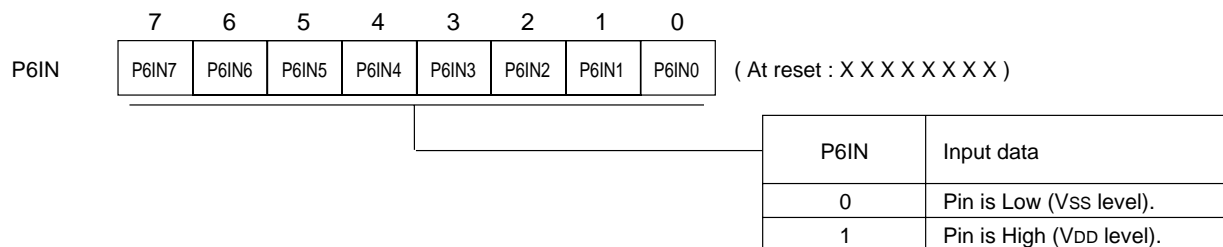
**Table 4-8-1 Expansion pins (P60 to P67)**

Pins	In processor mode
	In memory expansion mode
P60	A0 (External memory address bp0)
P61	A1 (External memory address bp1)
P62	A2 (External memory address bp2)
P63	A3 (External memory address bp3)
P64	A4 (External memory address bp4)
P65	A5 (External memory address bp5)
P66	A6 (External memory address bp6)
P67	A7 (External memory address bp7)

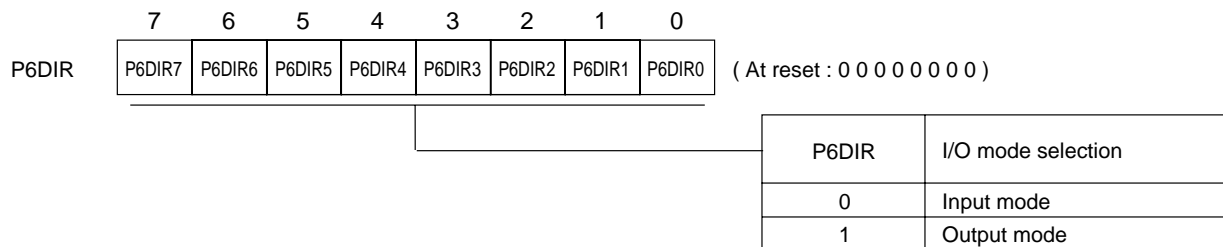
## 4-8-2 Registers



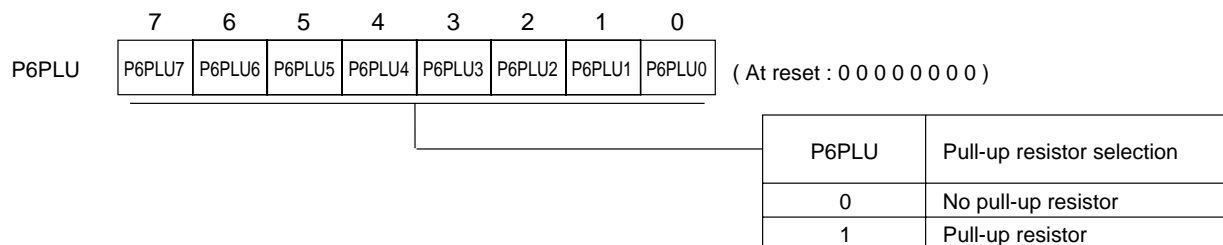
Port 6 output register (P6OUT : x'03F16', R/W)



Port 6 input register (P6IN : x'03F26', R)



Port 6 direction control register (P6DIR : x'03F36', R/W)



Port 6 pull-up resistor control register (P6PLU : x'03F46', R/W)

Figure 4-8-1 Port 6 Registers

### 4-8-3 Block Diagram

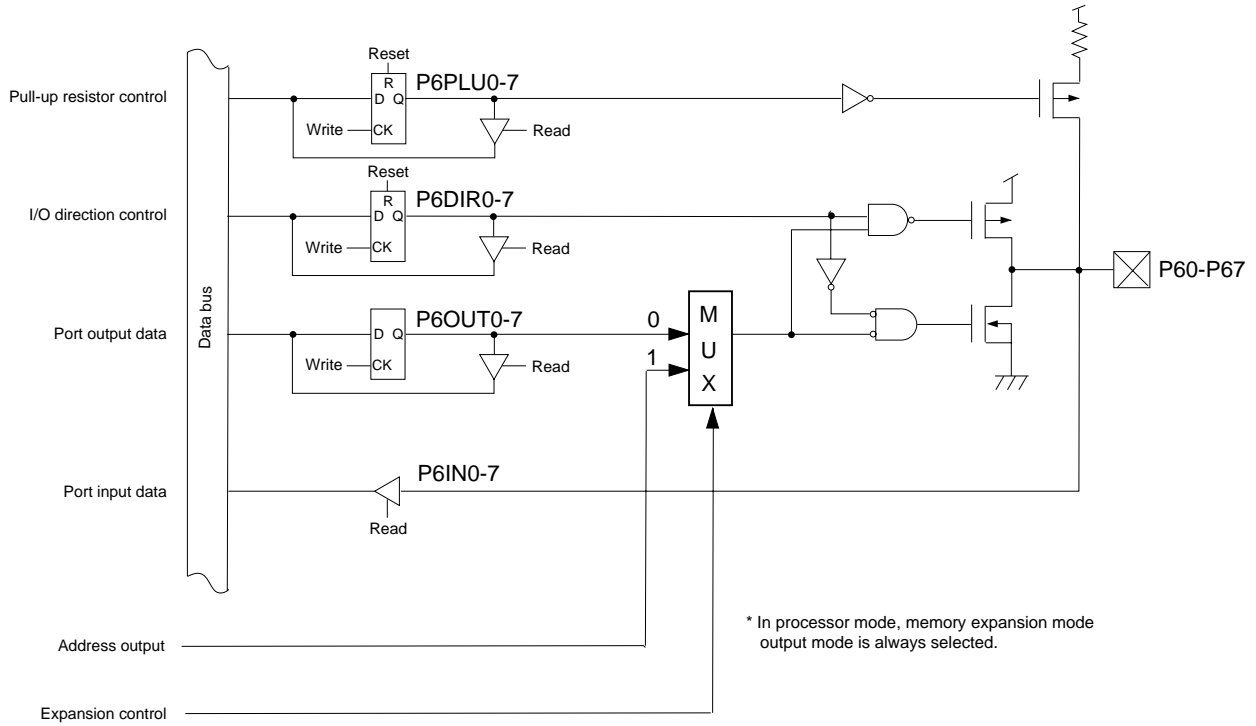


Figure 4-8-2 Block Diagram (P60 to P67)

## 4-9 Port 7

### 4-9-1 Description

#### ■General Port Setup

Each bit of the port 7 control I/O direction register (P7DIR) can be set individually to set pins as input or output. The control flag of the port 5 direction control register (P7DIR) is set to "1" for output mode, and "0" for input mode.

To read input data of pin, set the control flag of the port 7 direction control register (P7DIR) to "0" and read the value of the port 7 input register (P7IN).

To output data to pin, set the control flag of the port 7 direction control register (P7DIR) to "1" and write the value of the port 7 output register (P7OUT).

Each pin can be set individually if pull-up / pull-down resistor is added or not, by the port 7 pull-up / pull-down resistor control register (P7PLUD). Set the control flag of the port 7 pull-up / pull-down resistor control register (P7PLUD) to "1" to add pull-up or pull-down resistor. The pull-up / pull-down resistor selection register (FLOAT) select if pull-up resistor or pull-down resistor is added. The bp4 of the pull-up / pull-down resistor control register (FLOAT) is set to "1" for pull-down resistor, set to "0" for pull-up resistor.

#### ■Special Function Pin Setup

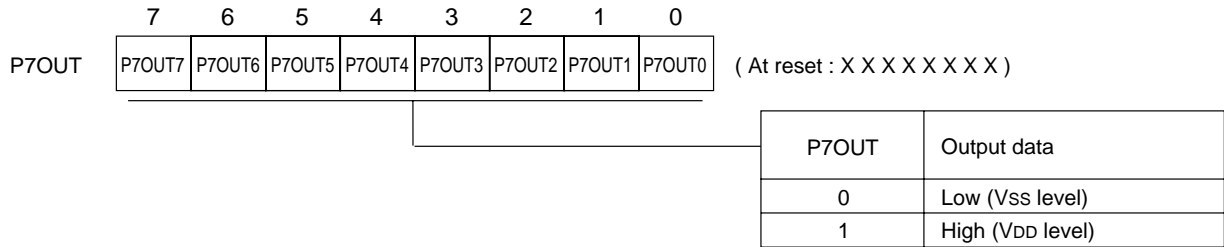
In processor mode or memory expansion mode, P70 to P77 are output pins to the expansion memory. But in memory expansion mode, the bp5 or bp6 of the address output control register (EXADV) set if they are used as address output pins or general I/O pins.

**Table 4-9-1 Expansion pins (P70 to P77)**

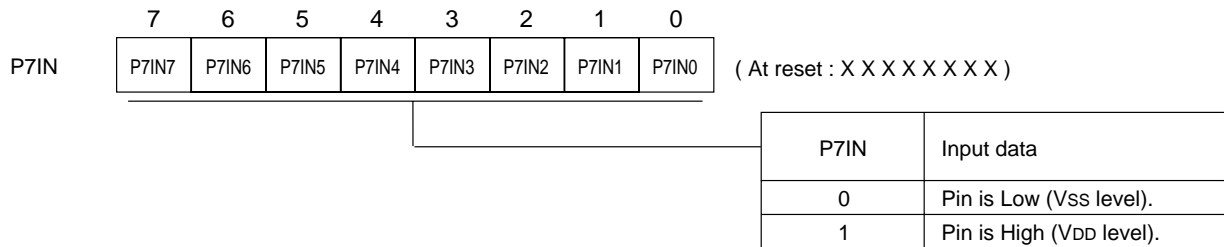
Pins	In processor mode In memory expansion mode *
P70	A8 (External memory address bp8)
P71	A9 (External memory address bp9)
P72	A10 (External memory address bp10)
P73	A11 (External memory address bp11)
P74	A12 (External memory address bp12)
P75	A13 (External memory address bp13)
P76	A14 (External memory address bp14)
P77	A15 (External memory address bp15)

\* In memory expansion mode, the bp5, 6 of the EXADV register should be set to "1" for P70 to P77 output address.

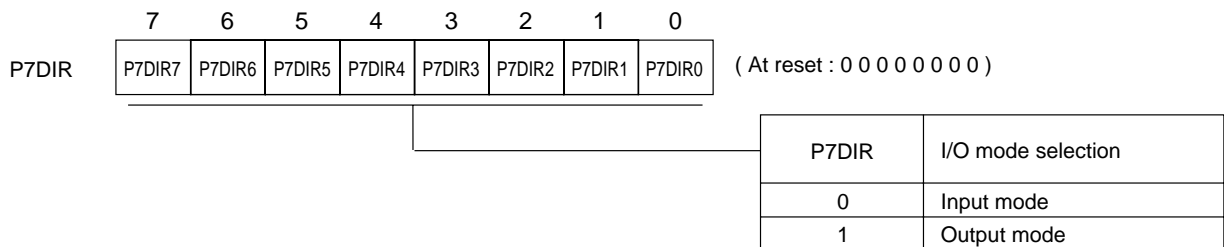
## 4-9-2 Registers



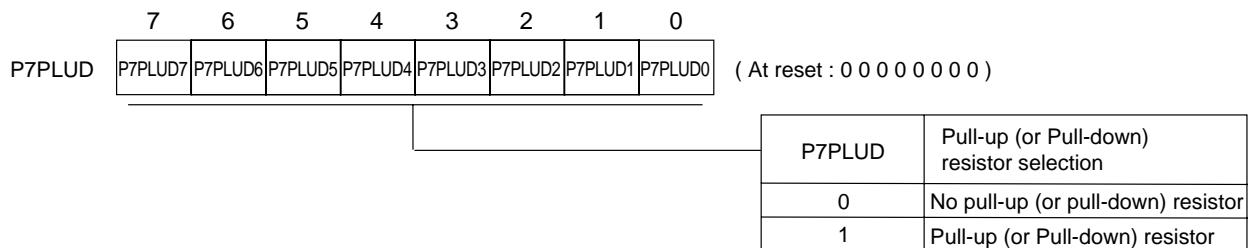
Port 7 output register (P7OUT : x'03F17', R/W)



Port 7 input register (P7IN : x'03F27', R)



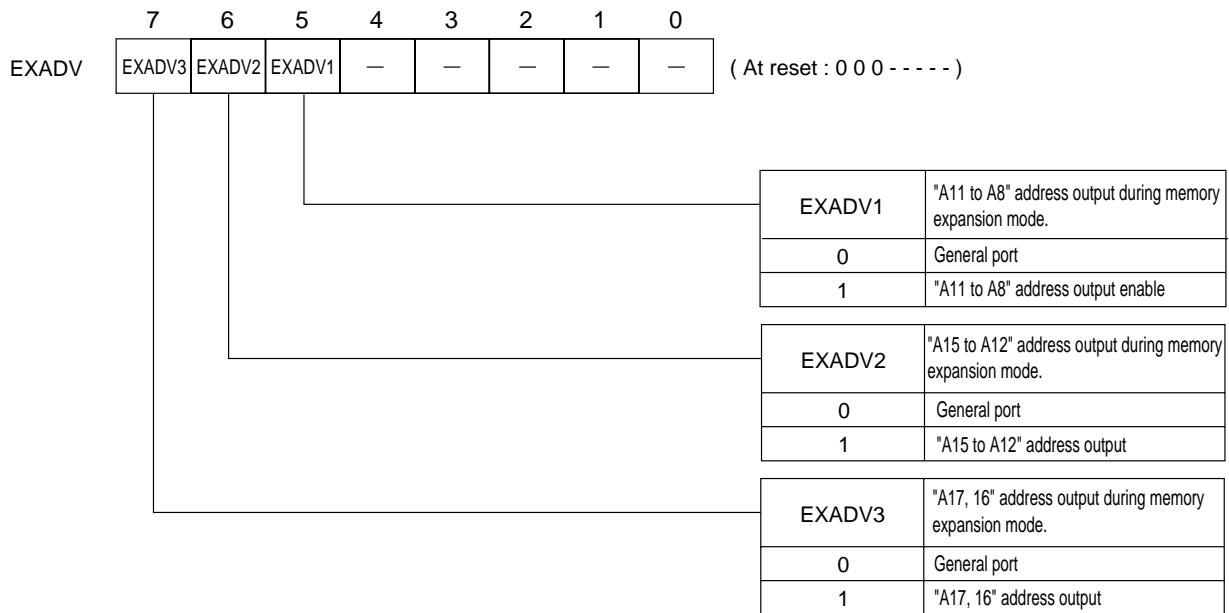
Port 7 direction control register (P7DIR : x'03F37', R/W)



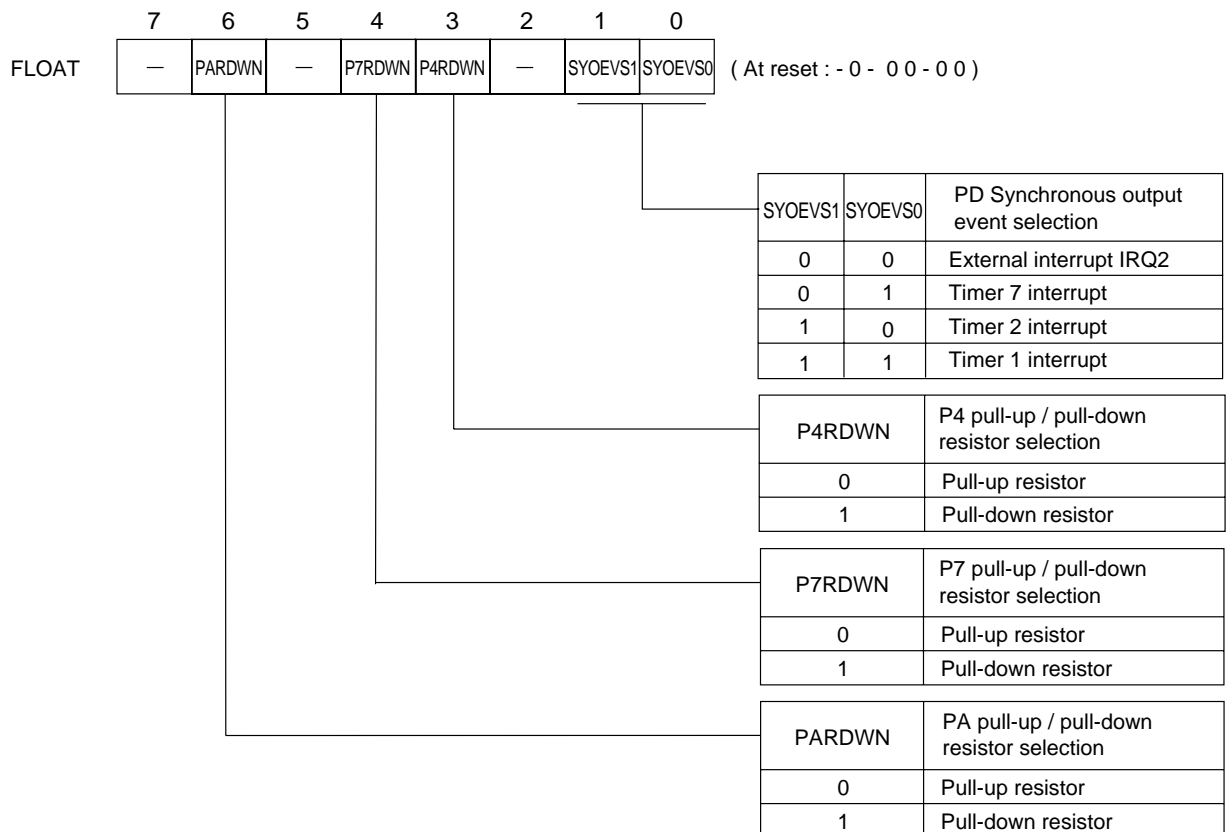
Port 7 pull-up / pull-down resistor control register (P7PLUD : x'03F47', R/W)

**Figure 4-9-1 Port 7 Registers (1/2)**





Address output control register (EXADV : x'03F0E', R/W)



Pull-up / Pull-down resistor selection, Pin control register (FLOAT : x'03F2E', R/W)

Figure 4-9-2 Port 7 Registers (2/2)

### 4-9-3 Block Diagram

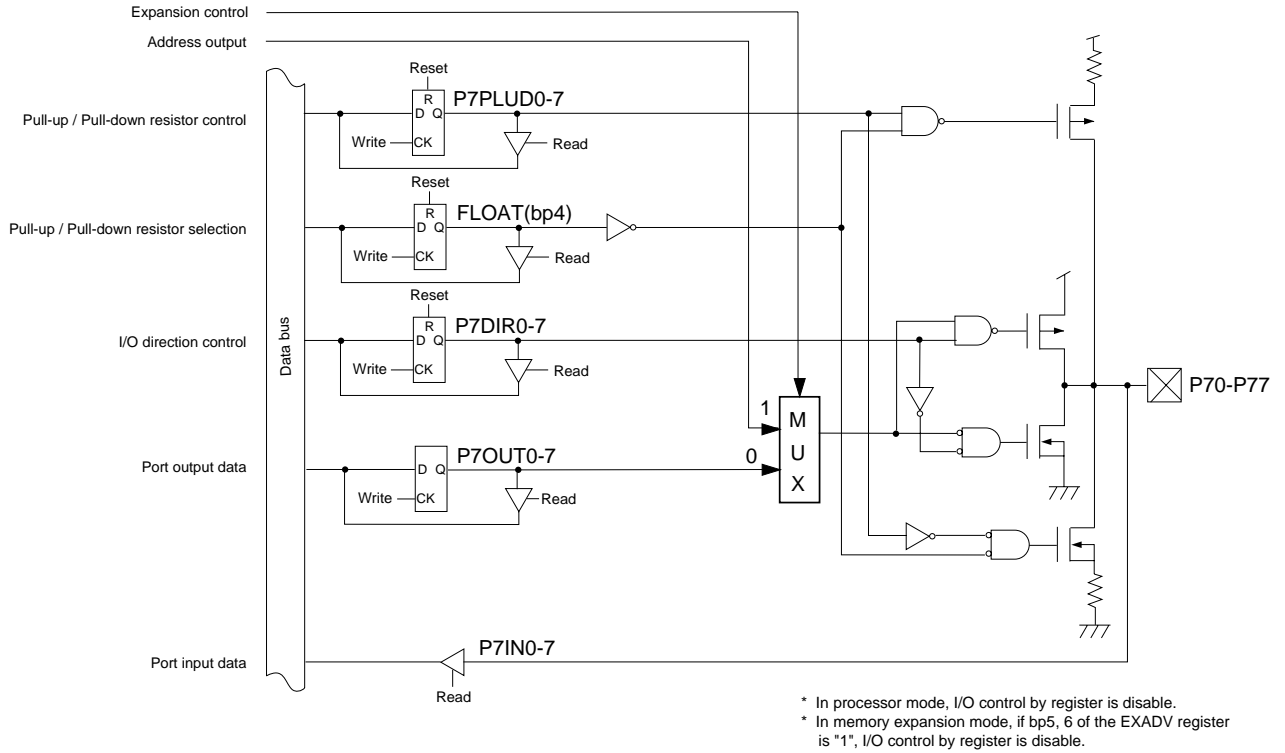


Figure 4-9-3 Block Diagram (P70 to P77)

## 4-10 Port 8

### 4-10-1 Description

#### ■ General Port Setup

Each bit of the port 8 control I/O direction register (P8DIR) can be set individually to set each pin as input or output. The control flag of the port 8 direction control register (P8DIR) is set to "1" for output mode, and "0" for input mode.

To read input data of pin, set the control flag of the port 8 direction control register (P8DIR) to "0" and read the value of the port 8 input register (P8IN).

To output data to pin, set the control flag of the port 8 direction control register (P8DIR) to "1" and write the value of the port 8 output register (P8OUT).

Each pin can be set individually if pull-up resistor is added or not, by the port 8 pull-up resistor control register (P8PLU). Set the control flag of the port 8 pull-up resistor control register (P8PLU) to "1" to add pull-up resistor.

#### ■ Special Function Pin Setup

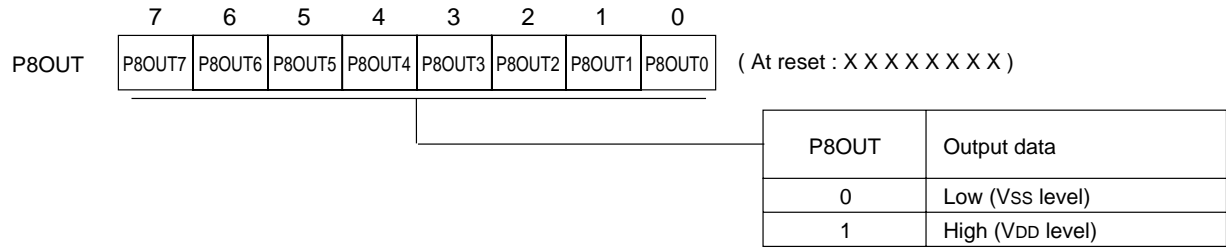
P80 to P87 are used as LED driving pins, as well.

In processor mode or memory expansion mode, P80 to P87 are I/O pins to the expansion memory. In those mode, any register cannot control input or output.

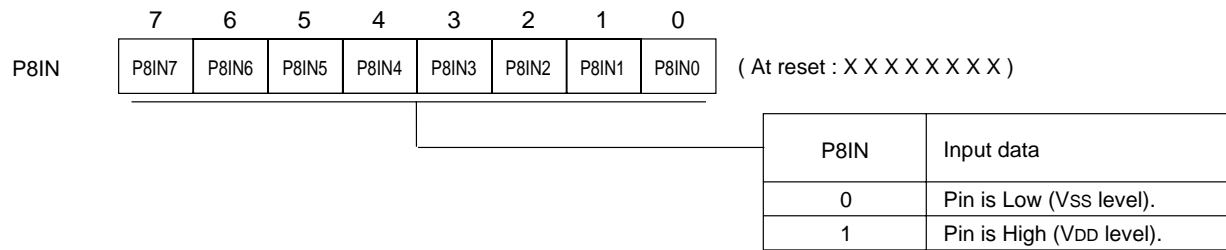
**Table 4-10-1 Expansion pins (P80 to P87)**

Pins	In processor mode In memory expansion mode
P80	D0 (External memory data bp0)
P81	D1 (External memory data bp1)
P82	D2 (External memory data bp2)
P83	D3 (External memory data bp3)
P84	D4 (External memory data bp4)
P85	D5 (External memory data bp5)
P86	D6 (External memory data bp6)
P87	D7 (External memory data bp7)

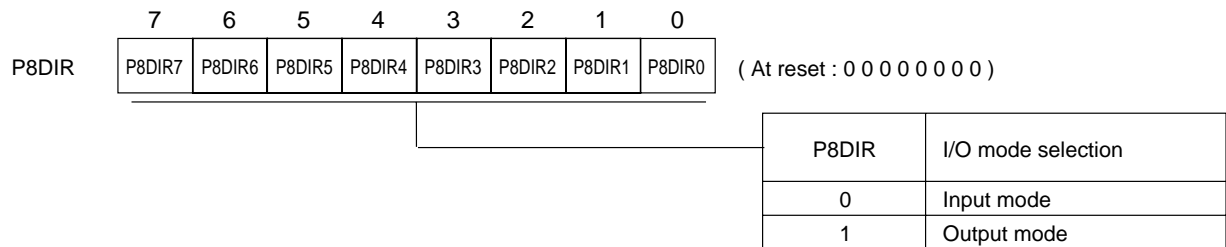
### 4-10-2 Registers



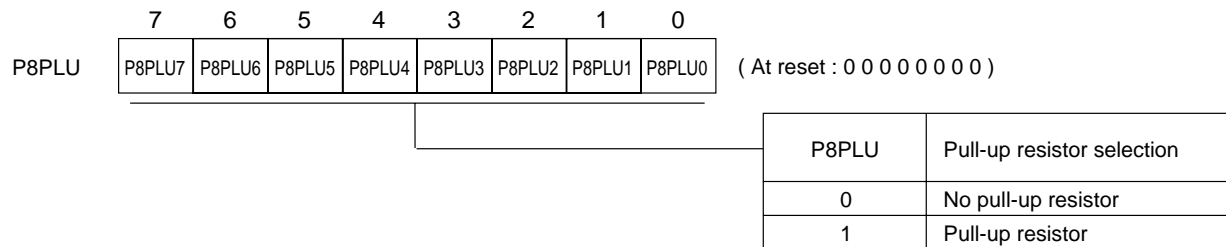
Port 8 output register (P8OUT : x'03F18', R/W)



Port 8 input register (P8IN : x'03F28', R)



Port 8 direction control register (P8DIR : x'03F38', R/W)



Port 8 pull-up resistor control register (P8PLU : x'03F48', R/W)

**Figure 4-10-1 Port 8 Registers**

### 4-10-3 Block Diagram

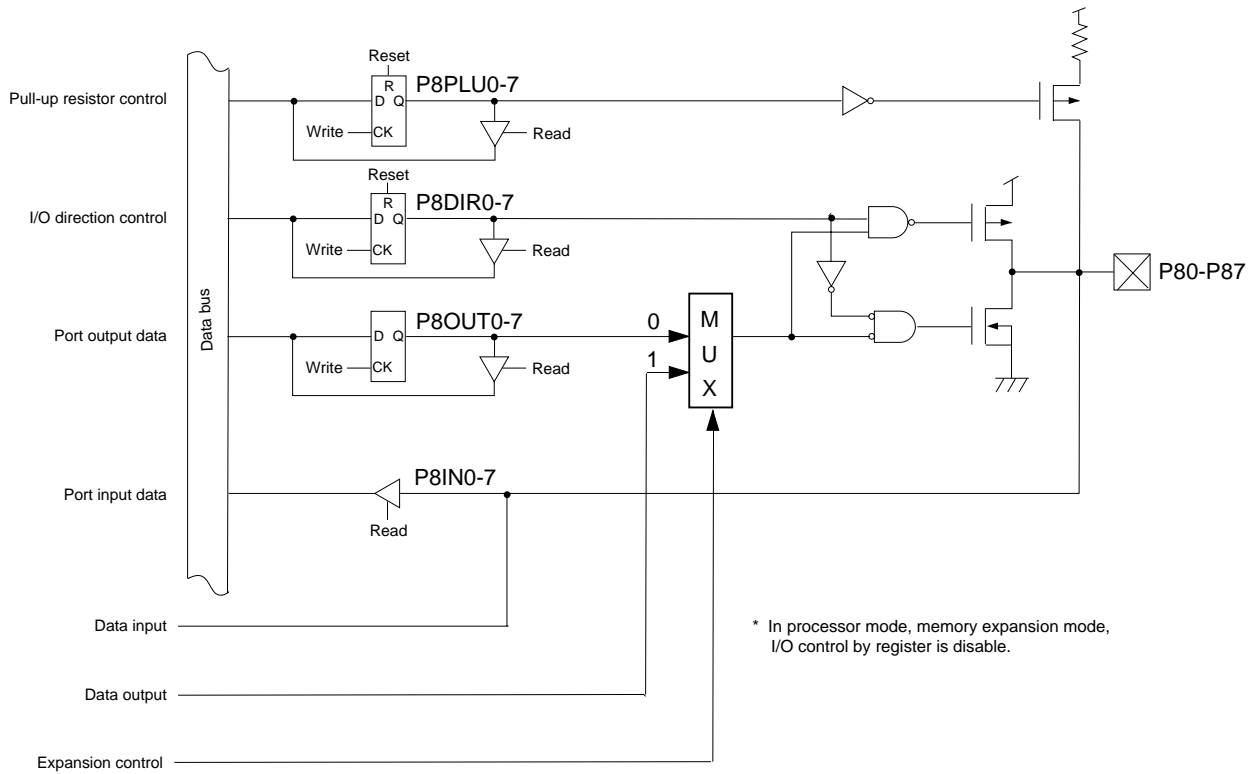


Figure 4-10-2 Block Diagram (P80 to P87)

## 4-11 Port A

### 4-11-1 Description

#### ■General Port Setup

Port A is input port. To read input data of pin, read the value of the port A input register (PAIN).

Each bit can be set individually if pull-up / pull-down resistor is added or not, by the port A pull-up / pull-down resistor control register (PAPLUD). Set the control flag of the port A pull-up / pull-down resistor control register (PAPLUD) to "1" to add pull-up or pull-down resistor. The pull-up / pull-down resistor selection register (FLOAT) select if pull-up resistor or pull-down resistor is added. The bp6 of the pull-up / pull-down resistor control register (FLOAT) is set to "1" for pull-down resistor, set to "0" for pull-up resistor.

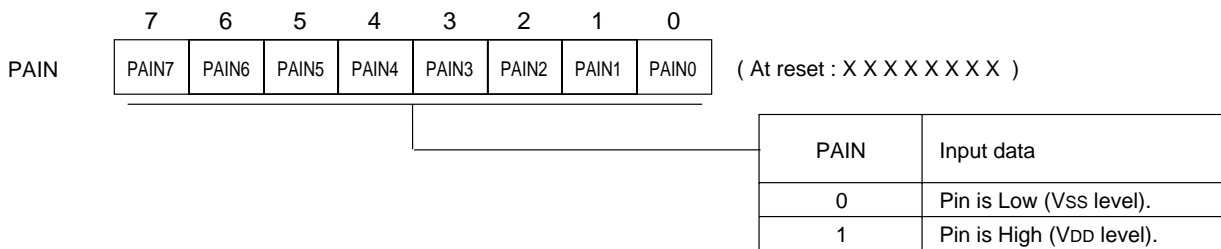
#### ■Special Function Pin Setup

PA0 to PA7 are used as input pins for analog. Each bit can be set individually as an input by the port A input mode register (PAIMD). When they are used as analog input pins, set the port A input mode register (PAIMD) to "1". Then, the value of the port A input register (PAIN) is read out "1".

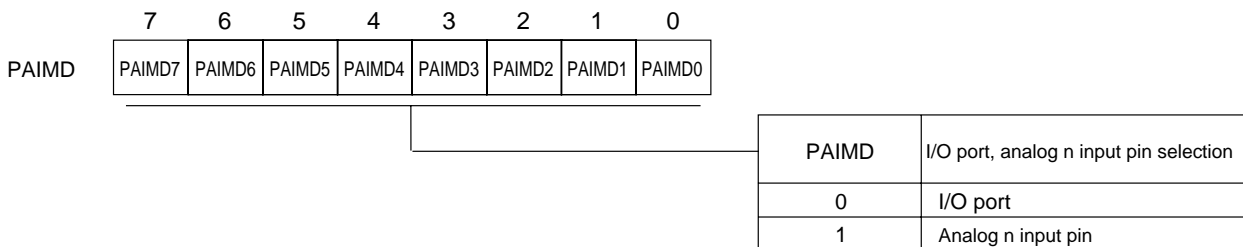


By setting the control flag of the PAIMD register to "1", the through current is not occurred when input voltage is at intermediate level.

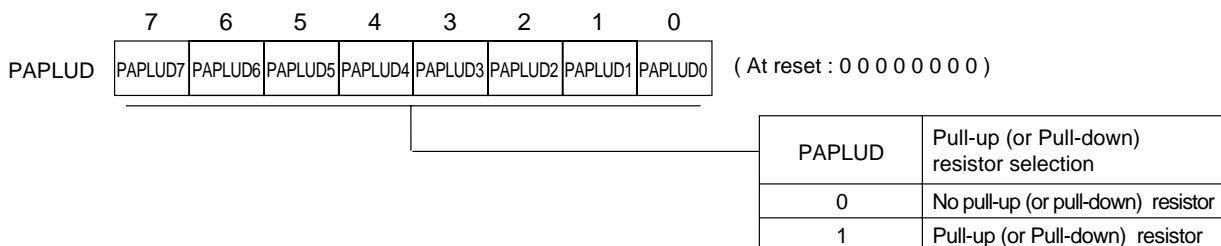
### 4-11-2 Registers



Port A input register (PAIN : x'03F2A', R)

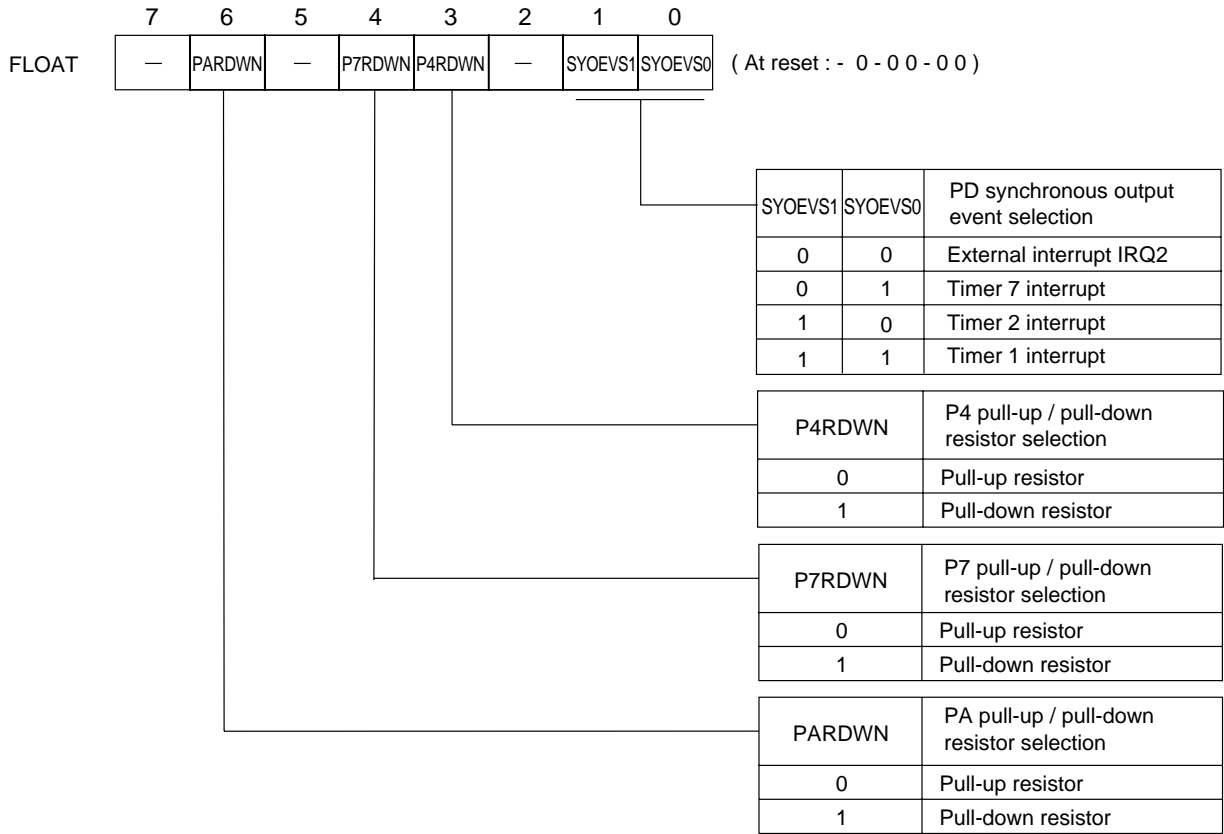


Port A input control register (PAIMD : x'03F3A', R/W)



Port A pull-up / pull-down resistor control register (PAPLUD : x'03F4A', R/W)

Figure 4-11-1 Port A Registers (1/2)



Pull-up / Pull-down resistor selection, Pin control register (FLOAT : x'03F2E', R/W)

**Figure 4-11-2 Port A Registers (2/2)**



### 4-11-3 Block Diagram

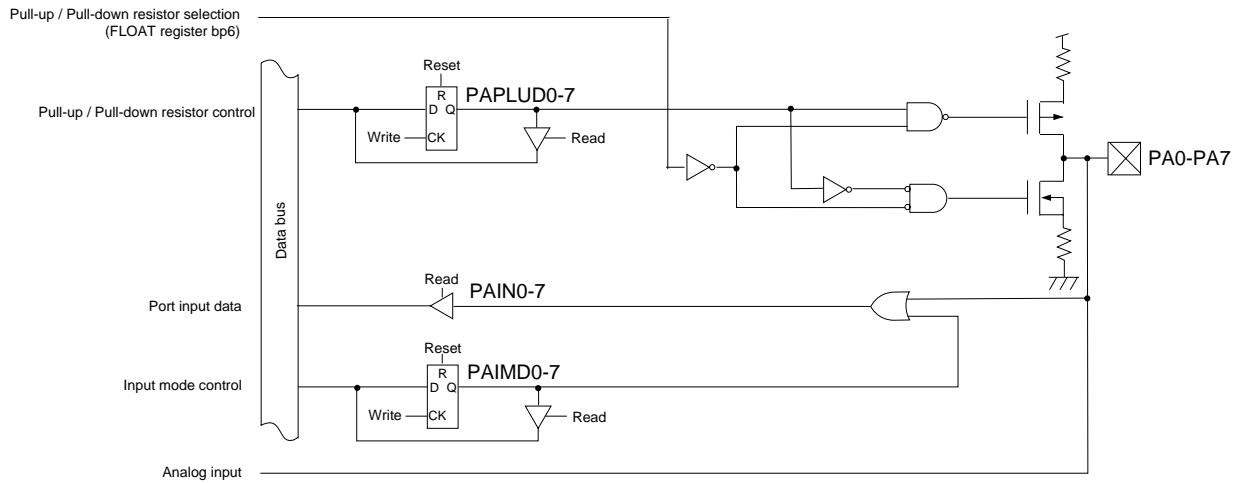


Figure 4-11-3 Block Diagram (PA0 to PA7)

## 4-12 Port C

### 4-12-1 Description

#### ■General Port Setup

Each bit of the port C control I/O direction register (PCDIR) can be set individually to set pins as input or output. The control flag of the port C direction control register (PCDIR) is set to "1" for output mode, and "0" for input mode.

To read input data of pin, set the control flag of the port C direction control register (PCDIR) to "0" and read the value of the port C input register (PCIN).

To output data to pin, set the control flag of the port C direction control register (PCDIR) to "1" and write the value of the port C output register (PCOUT).

Each pin can be set individually if pull-up resistor is added or not, by the port C pull-up resistor control register (PCPLU). Set the control flag of the port C pull-up resistor control register (PCPLU) to "1" to add pull-up resistor.

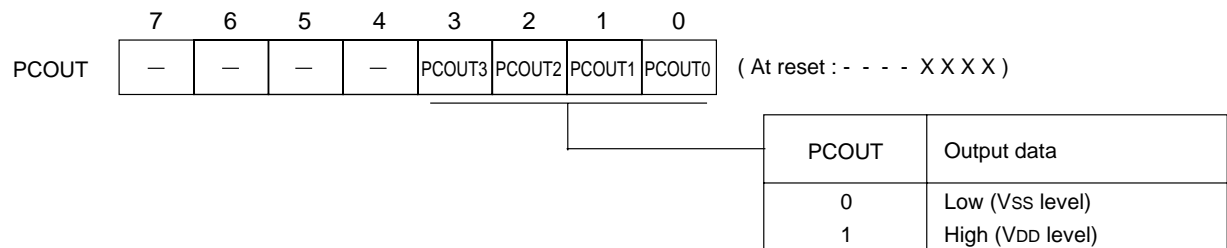
#### ■Special Function Pin Setup

PC0 to PC3 are used as DA output pins, as well. During DA converting, the port C input register (PCIN) indicates "1".

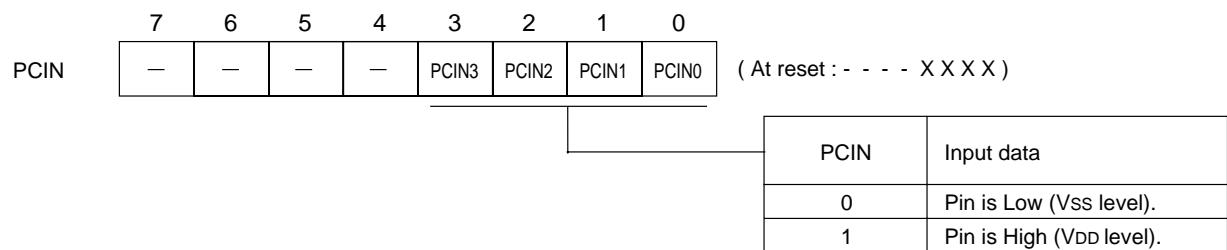


For not to occur the through current, add the pull-up resistor when PC0 to PC3 are used as output pin for DA and analog output is not used.

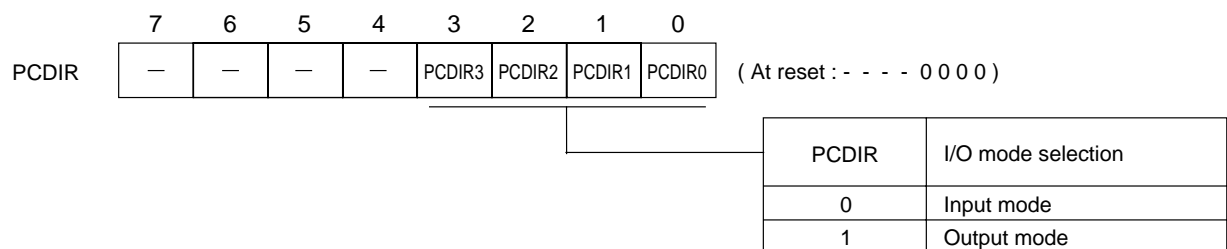
### 4-12-2 Registers



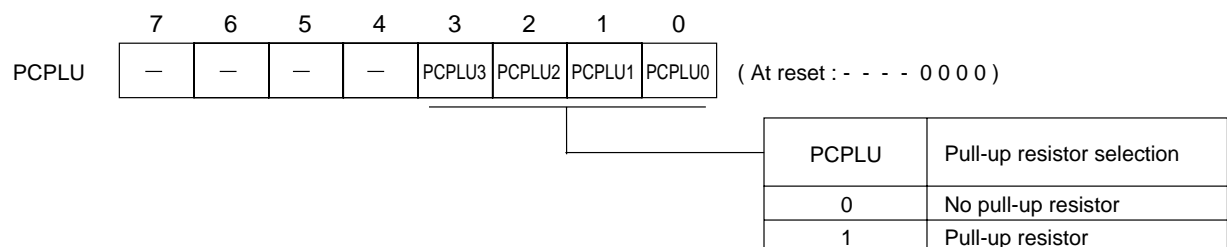
Port C output register (PCOUT : x'03F1C', R/W)



Port C input register (PCIN : x'03F2C', R)



Port C direction control register (PCDIR : x'03F3C', R/W)



Port C pull-up resistor control register (PCPLU : x'03F4C', R/W)

Figure 4-12-1 Port C Registers

### 4-12-3 Block Diagram

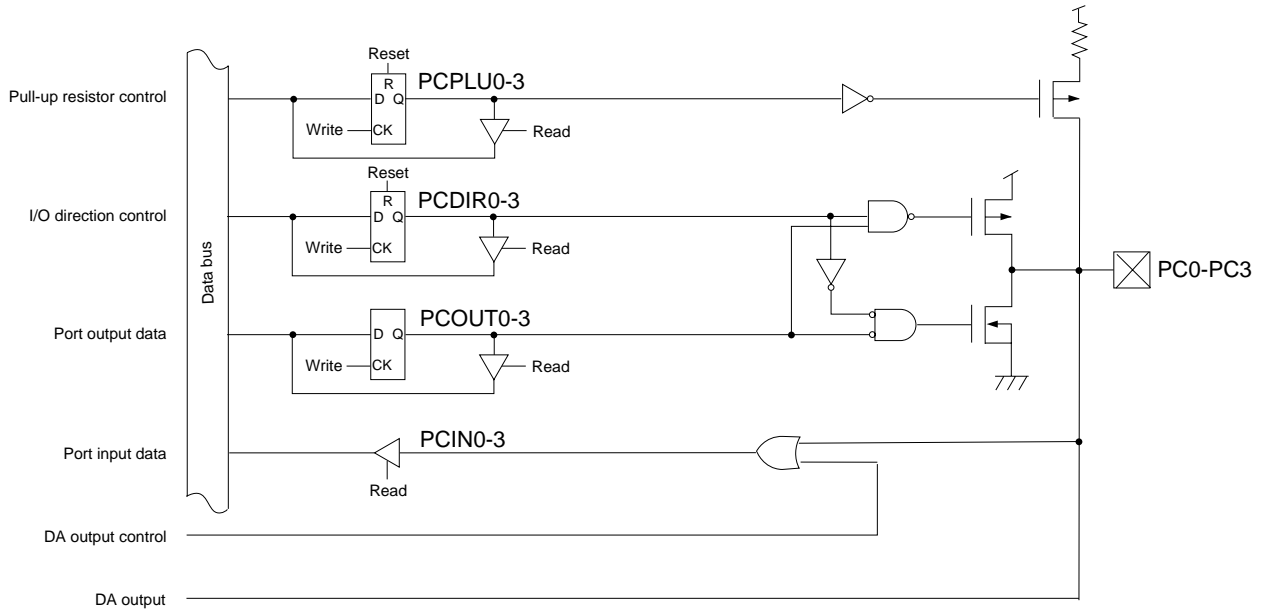


Figure 4-12-2 Block Diagram (PC0 to PC3)

## 4-13 Port D

### 4-13-1 Description

#### ■General port Setup

Each bit of the port D control I/O direction register (PDDIR) can be set individually to set pins as input or output. The control flag of the port D direction control register (PDDIR) is set to "1" for output mode, and "0" for input mode.

To read input data of pin, set the control flag of the port D direction control register (PDDIR) to "0" and read the value of the port D input register (PDIN).

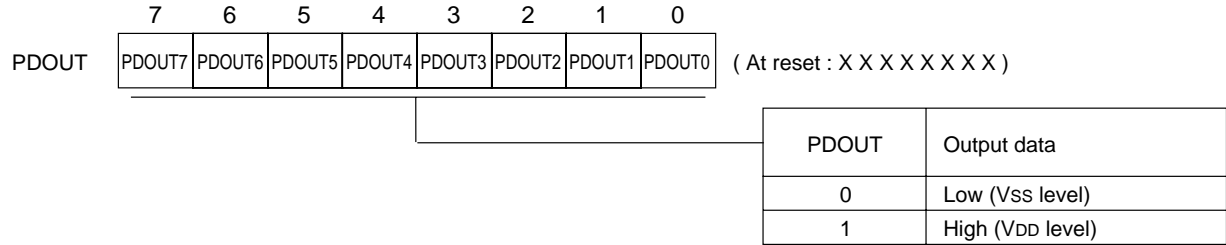
To output data to pin, set the control flag of the port D direction control register (PDDIR) to "1" and write the value of the port D output register (PDOUT).

Each pin can be set individually if pull-up resistor is added or not, by the port D pull-up resistor control register (PDPLU). Set the control flag of the port D pull-up resistor control register (PDPLU) to "1" to add pull-up resistor.

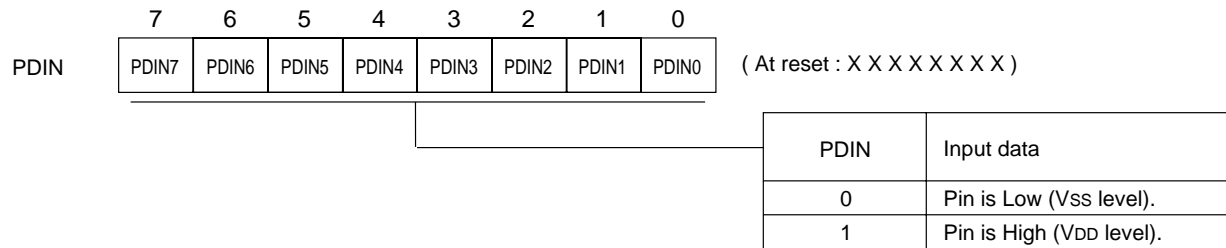
#### ■Special Function Pin Setup (Synchronous output of port)

Each bit can be set individually as synchronous output by the port D synchronous output control register (PDSYO). The port D synchronous output control register (PDSYO) is set to "1" for synchronous output, and "0" for general port. The pin control register (FLOAT) can select the event that generates synchronous output. When the bp 1, bp 0 of the pin control register (FLOAT) is "00", the external interrupt 2 (IRQ2) is selected. And "01" for the timer 7 interrupt, "10" for the timer 2 interrupt, "11" for the timer 1 interrupt. For more detail, refer to 4-15. Synchronous output function [p.IV-59].

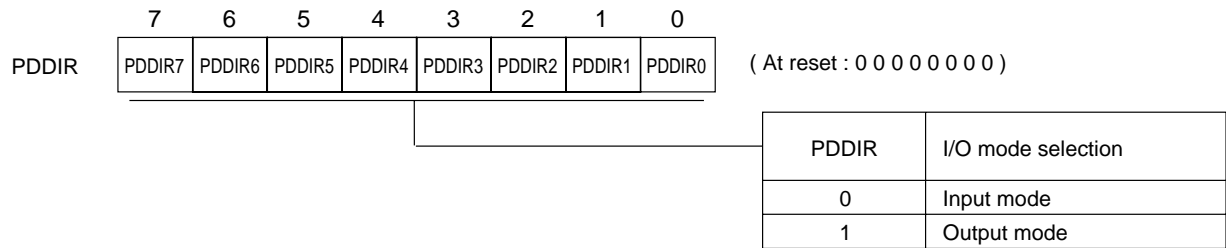
### 4-13-2 Registers



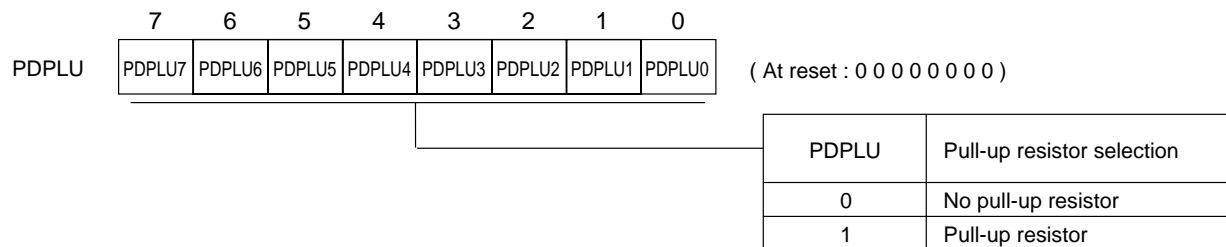
Port D output register (PDOUT : x'03F1D', R/W)



Port D input register (PDIN : x'03F2D', R)

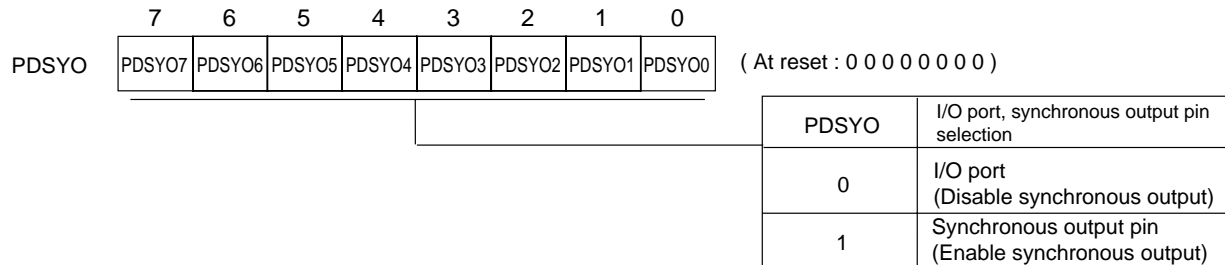


Port D direction control register (PDDIR : x'03F3D', R/W)

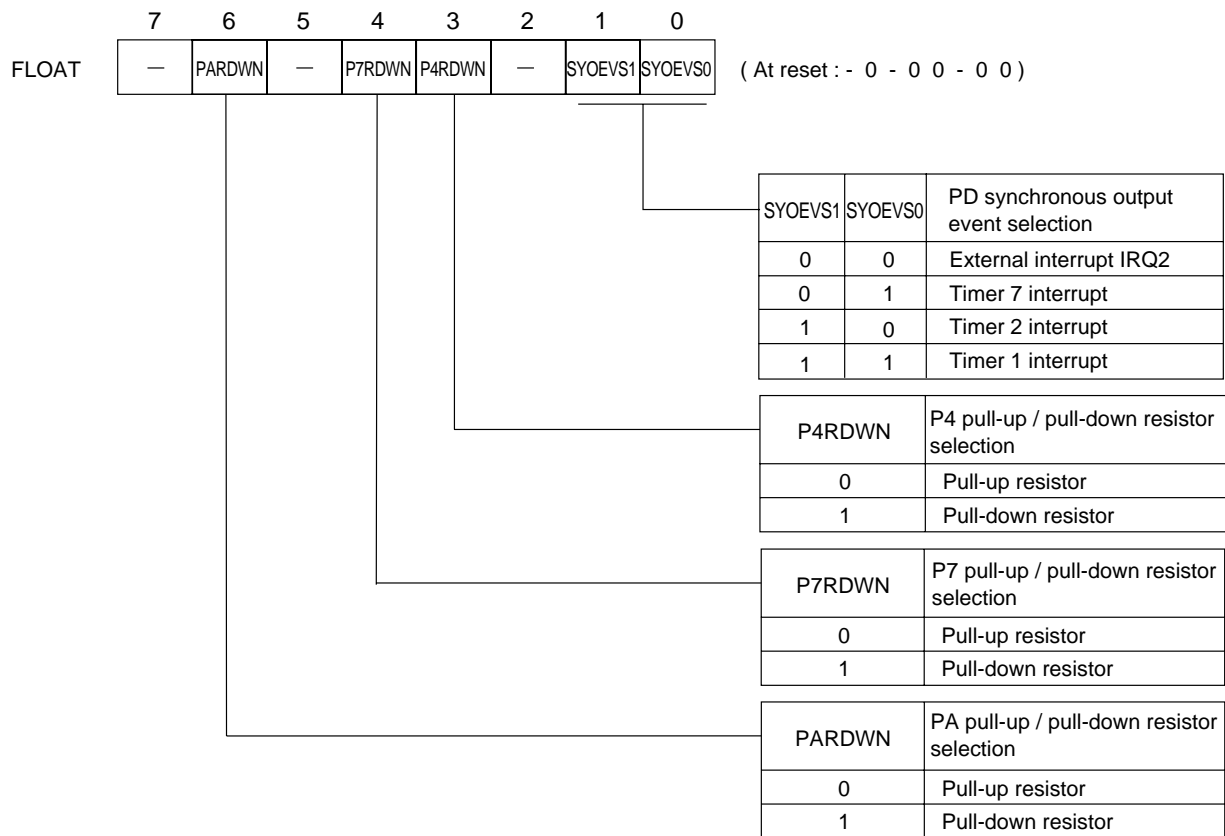


Port D pull-up resistor control register (PDPLU : x'03F4D', R/W)

Figure 4-13-1 Port D Registers (1/2)



Port D synchronous output control register (PDSYO : x'03F1F', R/W)



Pull-up / Pull-down resistor selection, pin control register (FLOAT : x'03F2E', R/W)

Figure 4-13-2 Port D Registers (2/2)

### 4-13-3 Block Diagram

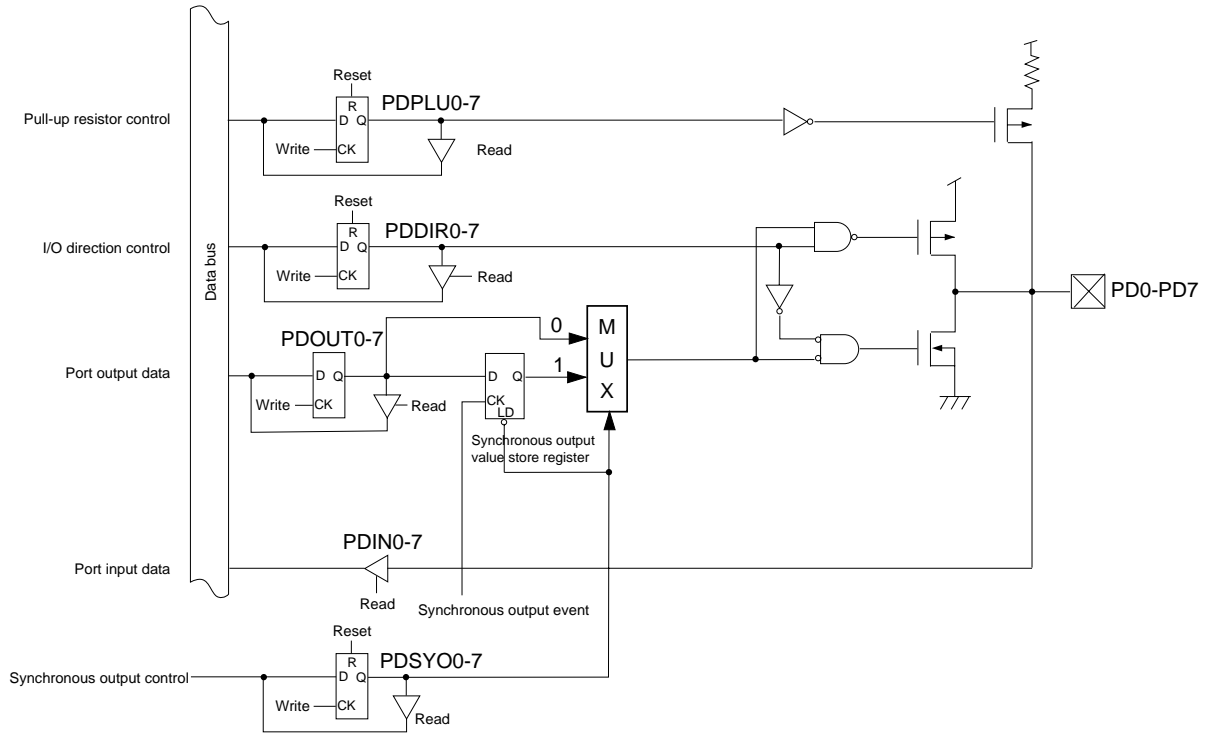


Figure 4-13-3 Block Diagram (PD0 to PD7)



## 4-14 Real Time Output Control (Port 1)

P10 , P12 and P14 has a real time output function that can switch pin's output at the falling edge of the external interrupt 0 pin (P20/IRQ0).

Real time control can change timer output signal (PWM output, timer pulse output, remote control carrier output), without setting on the program, in synchronization with external event. Output levels to be switched at event generation are 3 ; "0", "1" and "high impedance (Hi-z)".

### 4-14-1 Registers

Table 4-14-1 shows the real time output control register of port 1.

**Table 4-14-1 Real Time Output Control Registers**

	Register	Address	R/W	Function	Page
Port 1	P1OUT	x'03F11'	R/W	Port 1 output register	IV - 14
	P1OMD	x'03F2F'	R/W	Port 1 output mode register	IV - 15
	P1DIR	x'03F31'	R/W	Port 1 direction control register	IV - 14
	P1PLU	x'03F41'	R/W	Port 1 pull-up control register	IV - 14
	P1TCNT	x'03F7E'	R/W	Port 1 output control register	IV - 16

## 4-14-2 Operation

### ■Real Time Output Pin Setup

The real time output pin is set by the port 1 output control register(P1TCNT). The selectable pins are P10, P12 and P14. Those can be specified by each pin. Select the output mode by the port 1 direction control register (P1DIR).

There are 3 output levels ; "0", "1" and "High impedance(Hi-z)". Those are switched at the falling edge of the external interrupt 0 pin (P20/IRQ0). At high impedance, port becomes input mode.

The real time control changes the timer output signal (PWM output, timer pulse output, remote control carrier output) in synchronization with the external event, but it is also valid on normal port output.

When the I/O port (disable the real time control) is selected by the port 1 output control register (P1TCNT), the output level is not changed even if the switching event is generated. When it is used as general port, set this mode.

### ■Real Time Output Control Operation

After the port 1 output control register (P1TCNT) is set, the function selected by the port 1 output mode register (P1OMD) is output from the pin until the falling edge at the external interrupt 0 pin (P20/IRQ0) is generated.

Once the falling edge of the external interrupt 0 is generated, the pin's output is switched to the set level. The event of the falling edge is stored to the edge event save function shown at the figure 4-3-4. Block diagram (P10, P12, P14), and the set level of the port 1 output control register (P1TCNT) is output until the event data is cleared.

### ■Release Real Time Output (Clear the edge event save function)

Writing data to the port 1 output register (P1OUT) after event is generated, makes the event data of the edge event save function cleared. And all pins' output data become the former data before event is generated. If the event is generated again, all pins' output level of the port 1 output control register (P1TCNT).

Set the pin's output to "I/O port (disable the real time control)" by setting the port 1 output control register (P1TCNT) to stop the real time control.



The active edge of IRQ0 is only falling edge, regardless of its setting at the external interrupt 0 control register (IRQ0ICR).



Write to the port 1 output register (P1OUT) to clear the event data of the edge event save function, before the real time output control function is used.

■ Timing

P1TCNT set level : "0" (Low) output

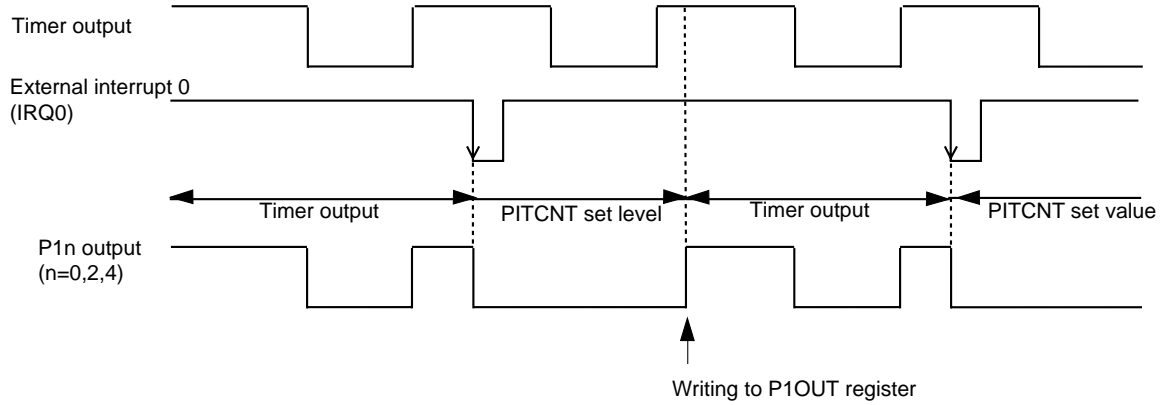


Figure 4-14-1 Real Time Output Control Timing

## 4-15 Synchronous output (Port D)

Port D has the synchronous output function that outputs the any set data to pins, in synchronization with the generation of the specified event. Synchronous event is selected from the external interrupt 2 (P22/IRQ2), timer 1 interrupt, timer 2 interrupt or timer 7 interrupt signal.

### 4-15-1 Block Diagram

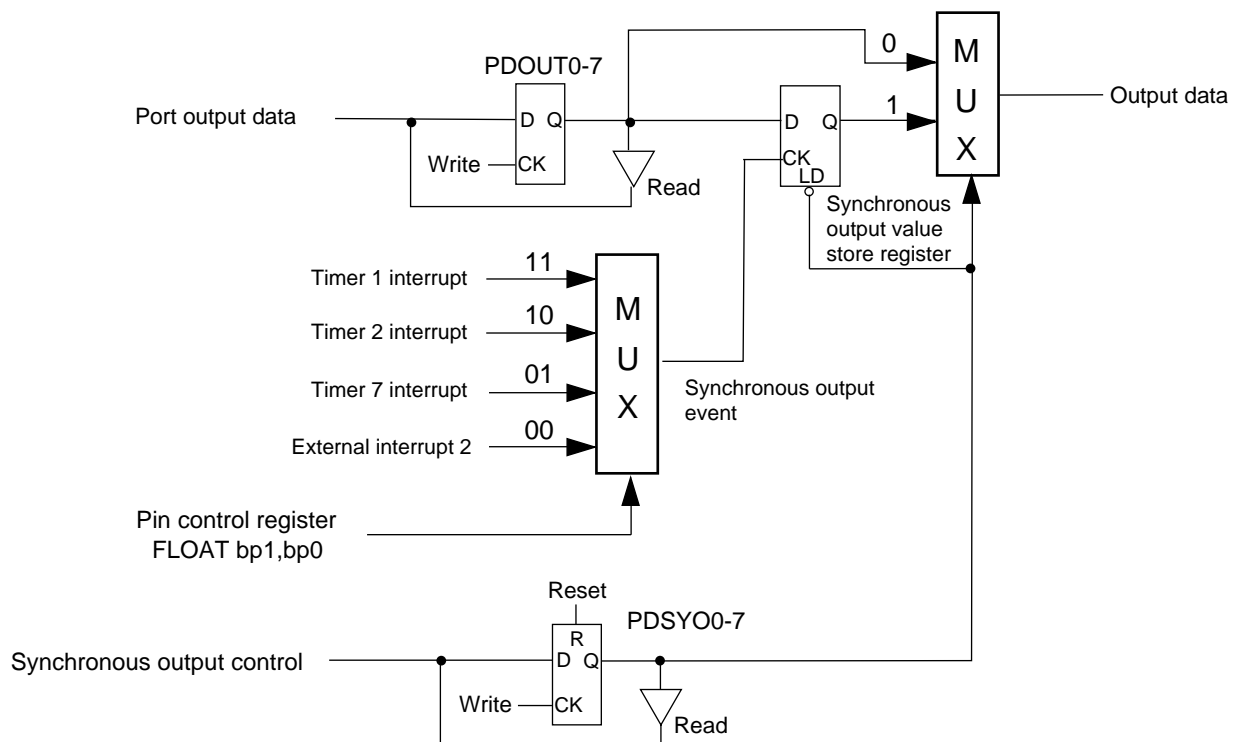


Figure 4-15-1 Synchronous Output Control Block Diagram

## 4-15-2 Registers

Table 4-15-1 shows the synchronous output control registers of port D.

**Table 4-15-1 Synchronous Output Control Registers**

	Register	Address	R/W	Function	Page
Port D	FLOAT	x'03F2E'	R/W	Pin control register 1	IV - 55
	PDSYO	x'03F1F'	R/W	Synchronous output control register	IV - 55
	PDDIR	x'03F3D'	R/W	Port D direction control register	IV - 54
	PDPLU	x'03F4D'	R/W	Port D Pull-up control register	IV - 54
	PDOUT	x'03F1D'	R/W	Port D output register	IV - 54

### 4-15-3 Operation

■Synchronous Output Setup

The synchronous output control register (PDSYO) selects the synchronous output pin of the port D, in each bit.

The synchronous output event is selected by the pin control register (FLOAT).

**Table 4-15-2 Synchronous Output Event**

		Page
Synchronous output port	Port D	IV - 52
Output event	External interrupt 2 (IRQ2)	III - 19, 45
	Timer 1	VI - 33
	Timer 2	VI - 33
	Timer7	VII - 31


When the external interrupt 2 (IRQ2) is selected, the interrupt edge should be specified. The interrupt edge can be specified by the external interrupt 2 control register (IRQ2ICR) or the both edges interrupt control register (EDGDT). The synchronous output recognizes the generation of the specified edge as an event.

■Synchronous Output Operation

When the synchronous output control register (PDSYO) is set to disable the synchronous output (I/O port), the port D is functioned as a general port. When the port D is set to disable the synchronous output, the same value to the port D output register (PDOUT) is always loaded to the synchronous output value stored register. (Figure 4-15-1. Block Diagram)

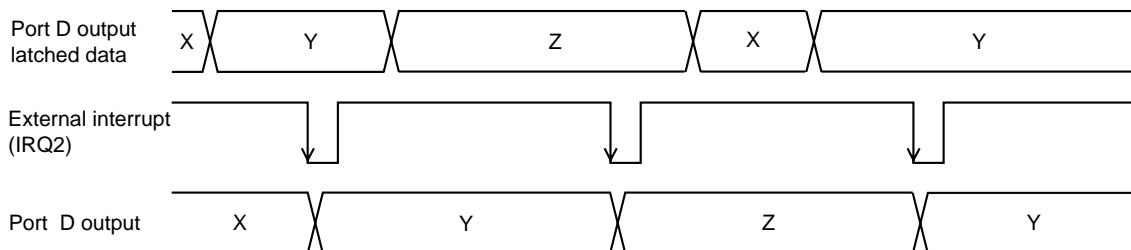
After the output mode is selected by the port D direction control register (PDDIR), if the synchronous output is enabled by the synchronous output control register (PDSYO), the value of the synchronous output value stored register is output from pins. If the synchronous output event that is set by the pin control register (FLOAT) is never generated, the synchronous output value stored register holds the same value when the synchronous output event is enabled.

Store the value that should be output from pin after the synchronous output event is generated, to the port D output register (PDOUT). Once the synchronous output event that is set by the pin control register (FLOAT) is generated, the data of the synchronous output value stored register is switched to the data of the port D output register (PDOUT), and the output value from pin is changed.

	<p>Before the synchronous output is enabled by the synchronous output control register (PDSYO), set the initial value of the synchronous output to the port D output register (PDOUT), in advance.</p>
---	--

### ■Port D Synchronous Output (External interrupt 2 IRQ2)

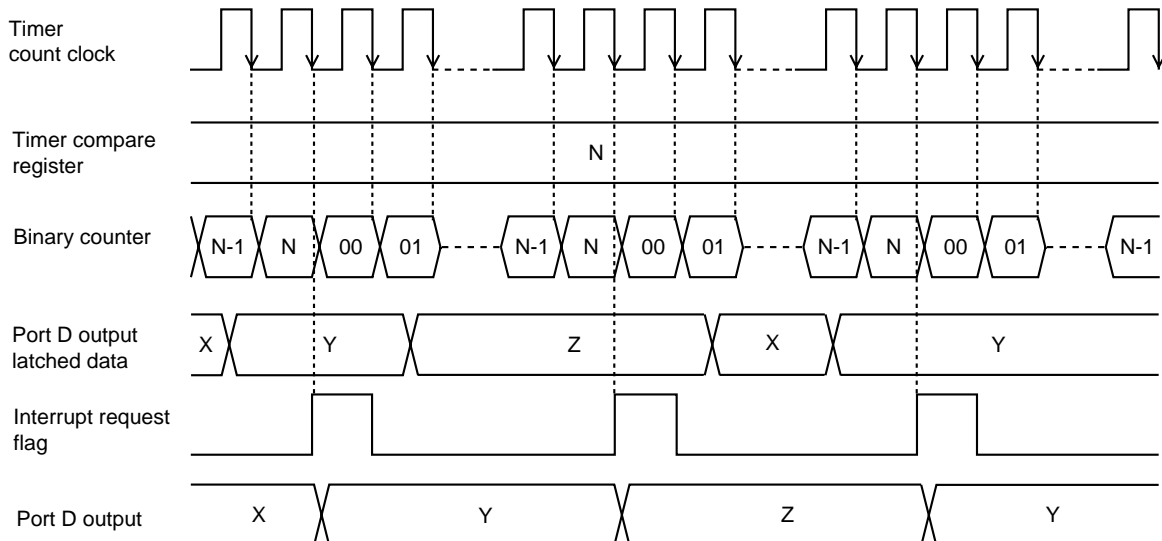
The synchronous output timing when the synchronous output event is set at the falling edge of the external interrupt 2, is shown below. The latched data on port D is output in synchronization with the falling edge of the IRQ2.



**Figure 4-15-2 Synchronous Output Timing by Event Generation (IRQ2)**

### ■Port D Synchronous Output (Timers 1,2 and 7)

The timer interrupt flag TMnIRQ is generated when binary counter and compare register are matched. The latched data on port D is output from the port D in synchronization with the rising edge of the TMnIRQ. About the setting of each timer operation, refer to chapter 6. 8-bit timers, and chapter 7. 16-bit timers.



**Figure 4-15-3 Synchronous Output Timing by Event Generation (Timers 1, 2 and 7)**

## 4-15-4 Setup Example

A setup example of the port D synchronous output by the external interrupt 2 (IRQ2) is shown as follows. As it is operated, the initial output data of port D is "55", the synchronous output data is "AA", and the rising edge of the IRQ2 is selected at the synchronous event.

An example setup procedure, with description of each step is shown below.

Setup Procedure	Description
(1) Select the synchronous output event. FLOAT (x'3F2E') bp1-0 :SYOEVS1-0 = 00	(1) Set the SYOEVS1-0 flag of the FLOAT register to "00" to set the synchronous output event to the IRQ2.
(2) Specify the interrupt edge. IRQ2ICR(x'3FE4') bp5 : REDG2 = 1 EDGDT(x'3F8F') bp2 : EDGSEL2 = 0	(2) Set the REDG2 flag of the IRQ2ICR register to "1" to set the active edge of the IRQ2 at the rising edge. Set the EDGSEL2 flag of the EDGDT register "0" to select the programmable active edge interrupt.
(3) Set the initial output data. PDOUT(x'3F1D') bp7-0 : PDOUT7-0 = x'55'	(3) Set the initial output data "55" to the PDOUT register. Port D outputs "55".
(4) Set the synchronous output pin. PDSYO(x'3F1F') bp7-0 : PDSYO7-0 = x'FF' PDDIR(x'3F3D') bp7-0 : PDDIR7-0 = x'FF'	(4) Set port D to synchronous output pin by setting the PDSYO7-0 flag of the PDSYO register to "FF". Select the output mode by setting the PDDIR7-0 flag of the PDDIR register to "FF".
(5) Set the synchronous output data. PDOUT(x'3F1D') bp7-0 : PDOUT7-0 = x'AA'	(5) Set the synchronous output data "AA" to the PDOUT register.
(6) Event is generated. Rising edge is generated at P22.	(6) Port D outputs "AA" at the rising edge of IRQ2.



## Chapter 5 Prescaler

## 5-1 Overview

This LSI has 2 prescalers that can be used by its peripheral functions at the same time. Each of them count with fosc or fs as a base clock. Its hardware is constructed as follows ;

Prescaler 0 (fosc count)	7 bits prescaler
Prescaler 1 (fs count)	3 bits prescaler

Prescaler 0 outputs fosc/2, fosc/4, fosc/16, fosc/32, fosc/64, fosc/128 as cycle clock. Prescaler 1 outputs fs/2, fs/4, fs/8 as cycle clock. Prescaler is used when cycle clock based fosc and fs is used on the following peripheral functions ;

- External interrupt 0 interface (with noise filter)
- External interrupt 1 interface (with noise filter)
- Timer 0 (8-bit timer counter)
- Timer 1 (8-bit timer counter)
- Timer 2 (8-bit timer counter)
- Timer 3 (8-bit timer counter)
- Timer 4 (8-bit timer counter)
- Serial interface 0 (Clock synchronous / Duplex UART)
- Serial interface 1 (Clock synchronous / Half-duplex UART)
- Serial interface 2 (Clock synchronous)
- Serial interface 3 (Clock synchronous / Single master IIC)
- D/A converter

About fosc, fs, refer to chapter 2. 2-5 Clock Switching [p.II-29].

## 5-1-1 Peripheral Functions

Table 5-1-1 shows several kinds of clock source that can be selected by each peripheral functions from prescaler output.

**Table 5-1-1 Peripheral Functions Used with Prescaler Output**

Clock source selection	Peripheral functions											
	External interrupt 0	External interrupt 1	Timer 0	Timer 1	Timer 2	Timer 3	Timer 4	Serial interface 0	Serial interface 1	Serial interface 2	Serial interface 3	D/A converter
fosc/2	-	-	-	-	-	-	-	√	√	√	√	-
fosc/4	-	-	√	√	√	√	√	√	√	√	√	-
fosc/16	-	-	√	√	√	√	√	√	√	√	√	-
fosc/32	-	-	√	-	√	-	√	-	-	√	√	-
fosc/64	-	-	√	√	√	√	√	√	√	-	-	-
fosc/128	√	√	-	√	-	√	-	-	-	-	-	-
fs/2	-	-	√	√	√	√	√	√	√	√	√	-
fs/4	-	-	√	-	√	-	√	√	√	√	√	-
fs/8	-	-	-	√	-	√	-	-	-	-	-	√
Timer 2 output	-	-	-	-	-	-	-	√	-	√	√	-
Timer 3 output	-	-	-	-	-	-	-	-	-	√	√	-
Timer 4 output	-	-	-	-	-	-	-	√	√	-	-	-

## 5-1-2 Block Diagram

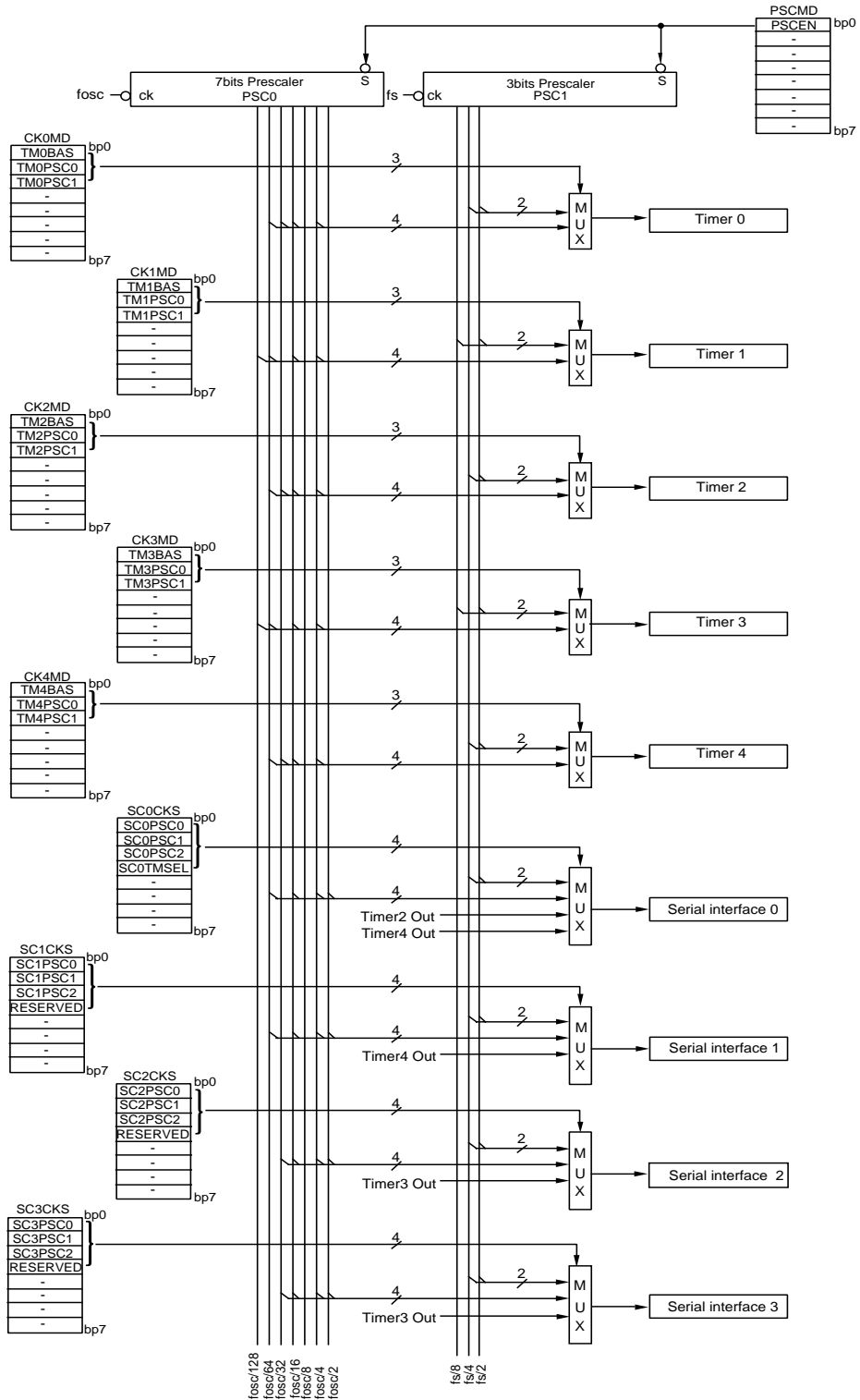


Figure 5-1-1 Prescaler Block Diagram

## 5-2 Control Register

### 5-2-1 Registers List

Table 5-2-1 shows registers to control prescaler.

**Table 5-2-1 Prescaler Control Registers**

Register	Address	R/W	Function	Page
PSCMD	x'03F6F'	R/W	Prescaler control register	V-6
CK0MD	x'03F56'	R/W	Timer 0 prescaler selection register	V-7
CK1MD	x'03F57'	R/W	Timer 1 prescaler selection register	V-7
CK2MD	x'03F5E'	R/W	Timer 2 prescaler selection register	V-8
CK3MD	x'03F5F'	R/W	Timer 3 prescaler selection register	V-8
CK4MD	x'03F66'	R/W	Timer 4 prescaler selection register	V-9
SC0CKS	x'03F97'	R/W	Serial interface 0 transfer clock selection register	V-10
SC1CKS	x'03F9F'	R/W	Serial interface1 transfer clock selection register	V-10
SC2CKS	x'03FA7'	R/W	Serial interface 2 transfer clock selection register	V-11
SC3CKS	x'03FAF'	R/W	Serial interface 3 transfer clock selection register	V-11

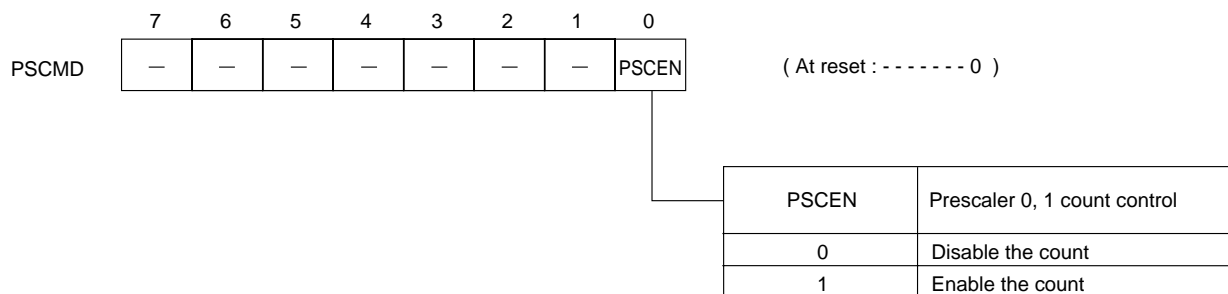
R/W : Readable/Writable

## 5-2-2 Control Registers

Registers that select prescaler outputs cycle clock and prescaler operation control, consists of the prescaler control register (PSCMD), the timer prescaler selection register (CKnMD) and the serial transfer clock selection register (SCnCKS).

The prescaler control register controls if counting of prescaler is permitted or not.

### ■ Prescaler Control Register (PSCMD)



**Figure 5-2-1 Prescaler Control Register (PSCMD : x'03F6F', R/W)**

The timer prescaler selection register selects the count clock that used in 8-bit timer.

■Timer 0 Prescaler Selection Register (CK0MD)

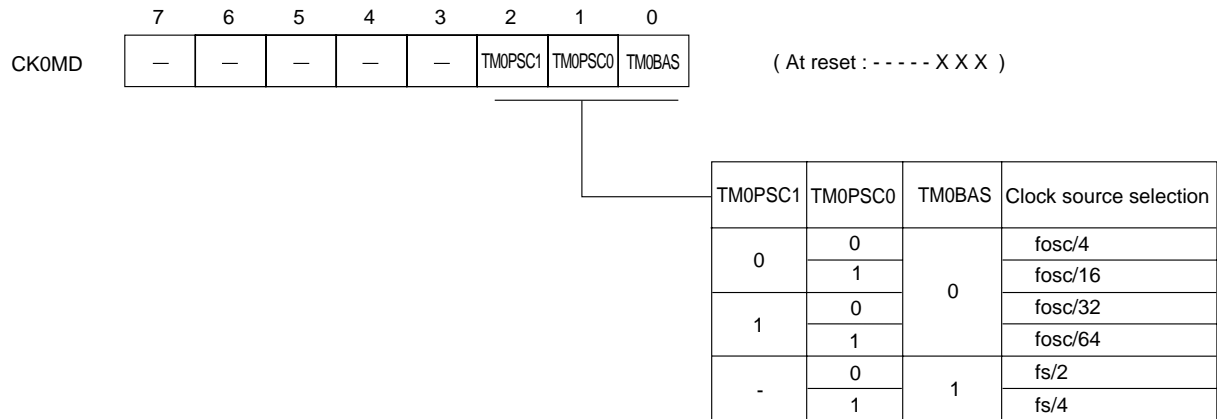


Figure 5-2-2 Timer 0 Prescaler Selection Register (CK0MD : x'03F56', R/W)

■Timer 1 prescaler selection register (CK1MD)

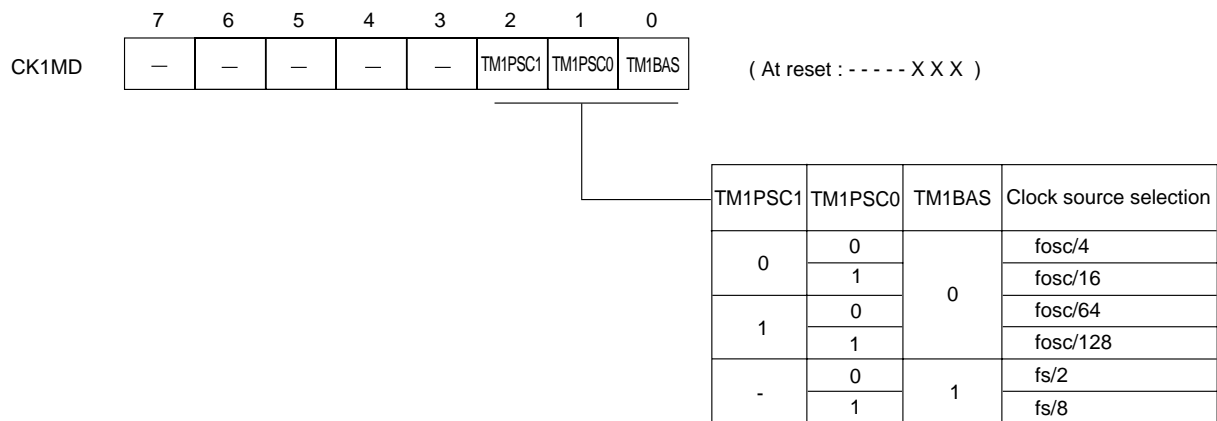


Figure 5-2-3 Timer 1 Prescaler Selection Register (CK1MD : x'03F57', R/W)

■Timer 2 Prescaler Selection Register (CK2MD)

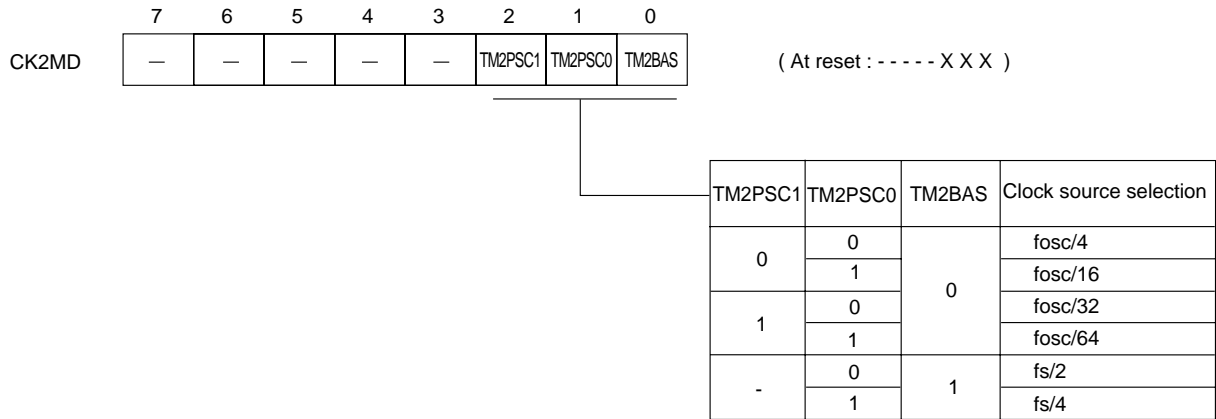


Figure 5-2-4 Timer 2 Prescaler Selection Register (CK2MD : x'03F5E', R/W)

■Timer 3 Prescaler Selection Register (CK3MD)

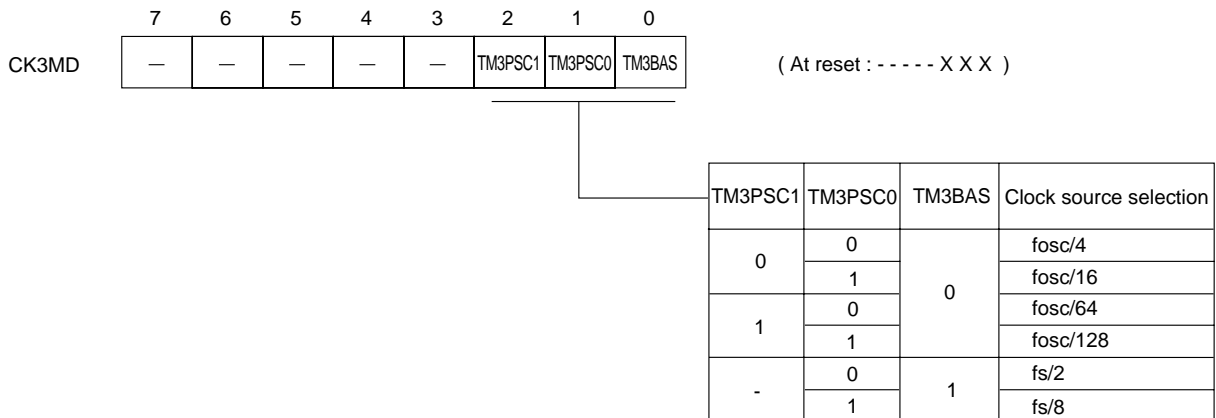
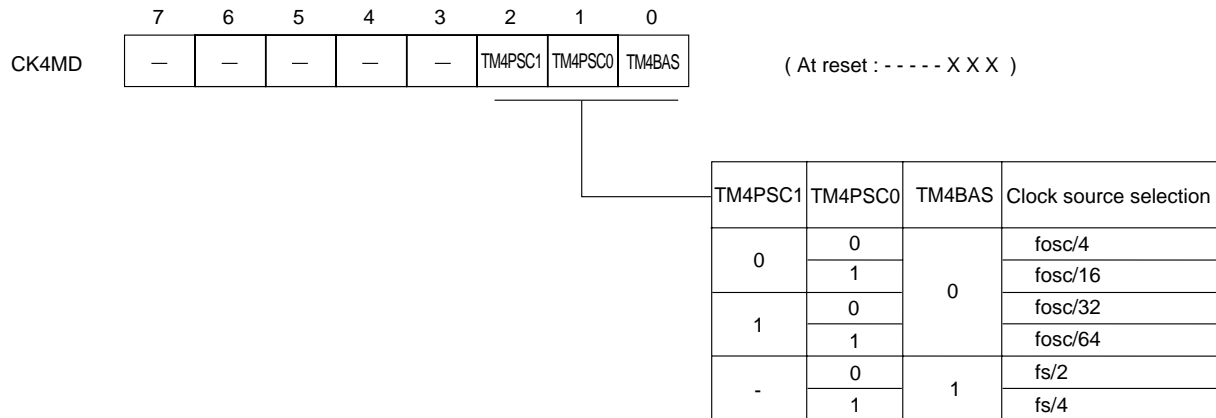


Figure 5-2-5 Timer 3 Prescaler Selection Register (CK3MD : x'03F5F', R/W)



### ■ Timer 4 Prescaler Selection Register (CK4MD)



**Figure 5-2-6** Timer 4 Prescaler Selection Register (CK4MD : x'03F66', R/W)

The serial interface transfer clock selection register (SCnCKS) selects the transfer clock used for serial data transfer.

■Serial Interface 0 Transfer Clock Selection Register (SC0CKS)

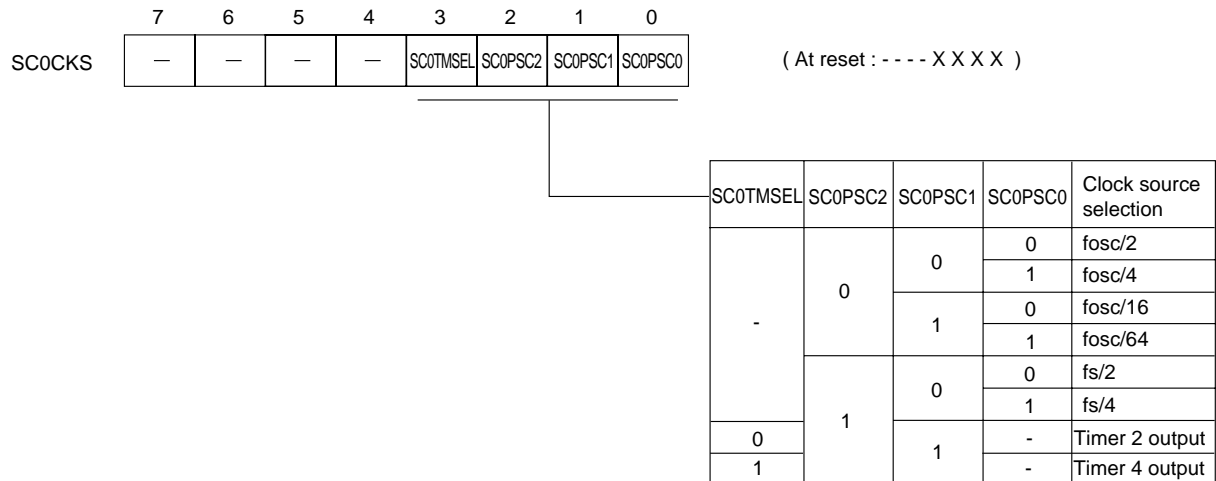


Figure 5-2-7 Serial Interface 0 Transfer Clock Selection Register (SC0CKS : x'03F97', R/W)

■Serial Interface 1 Transfer Clock Selection Register (SC1CKS)

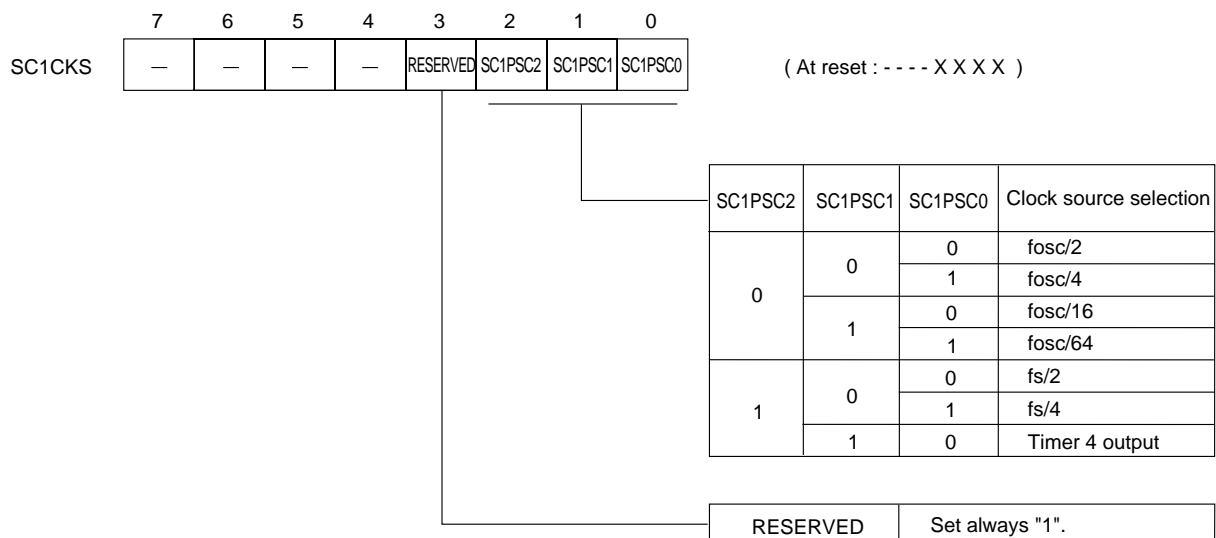


Figure 5-2-8 Serial Interface 1 Transfer Clock Selection Register (SC1CKS : x'03F9F', R/W)

■Serial Interface 2 Transfer Clock Selection Register (SC2CKS)

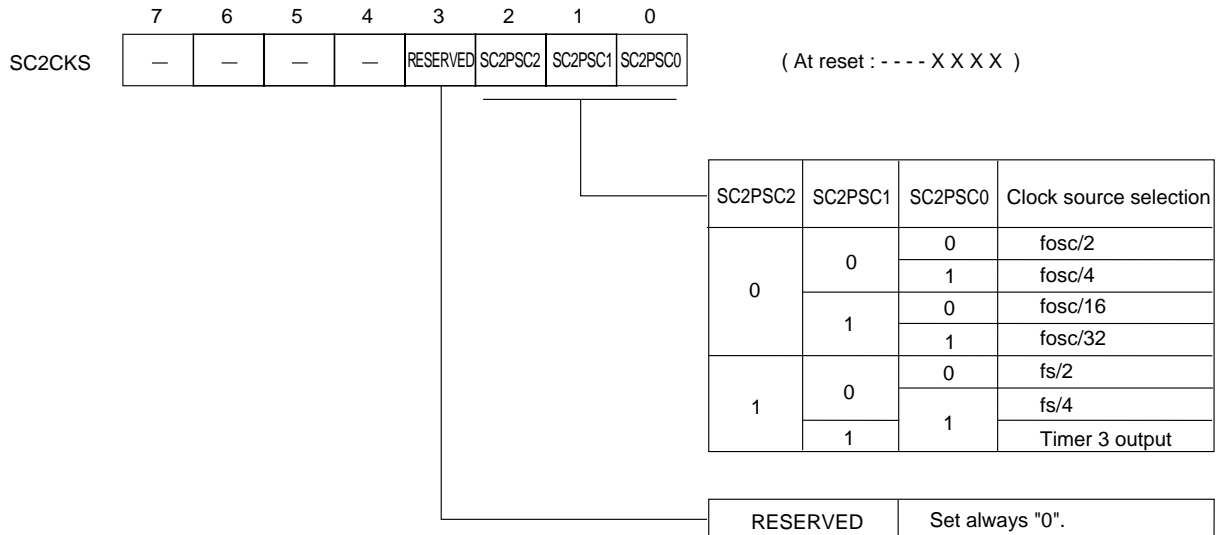


Figure 5-2-9 Serial Interface 2 Transfer Clock Selection Register (SC2CKS : x'03FA7', R/W)

■Serial Interface 3 Transfer Clock Selection Register (SC3CKS)

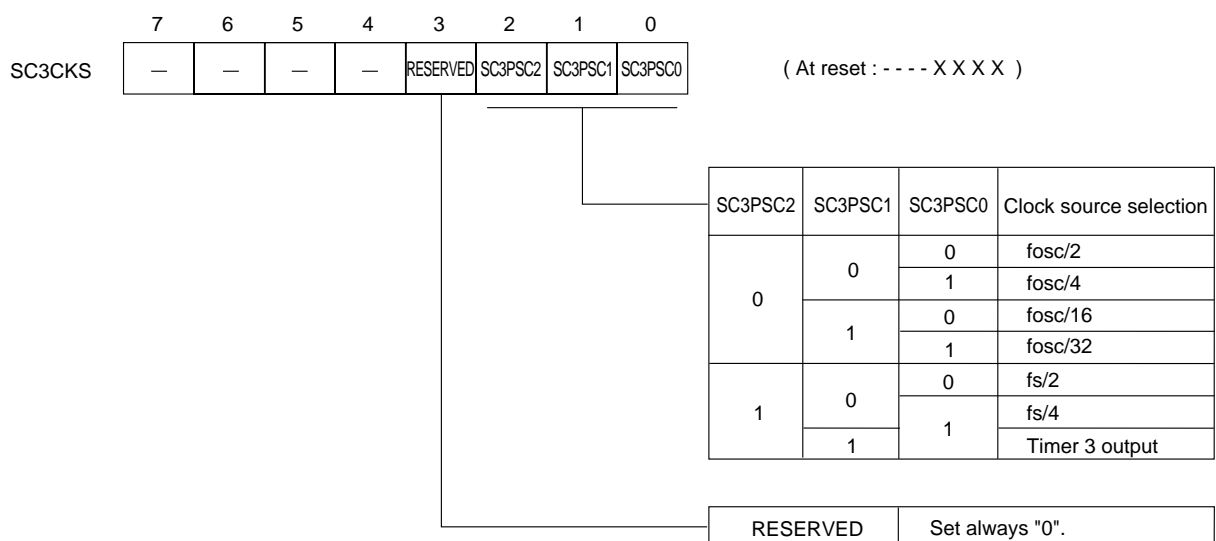


Figure 5-2-10 Serial Interface 3 Transfer Clock Selection Register (SC3CKS : x'03FAF', R/W)

## 5-3 Operation

### 5-3-1 Operation

#### ■ Prescaler Operation (Prescaler 0 to 1)

Prescaler 0 is a 7-bit and prescaler 1 is a 3-bit free-running counter that divides the base clock. This prescaler can be started or stopped by the PSCEN flag of the prescaler control register (PSCMD).

#### ■ Count Timing of Prescaler Operation (Prescalers 0 and 1)

Prescaler 0 counts up at the falling edge of fosc.

Prescaler 1 counts up at the falling edge of fs.

#### ■ Peripheral Functions with Prescaler Output Cycle Clock

Table 5-3-1 shows the prescaler output clock source that the peripheral functions can be used, and the registers that control the clock source selection.

**Table 5-3-1 Peripheral Functions Used with Prescaler Output Cycle Clock**

Peripheral functions		Control register
External interrupt 0	Noise filter sampling clock	-
External interrupt 1	Noise filter sampling clock	-
Timer 0	Count clock	CK0MD
Timer 1	Count clock	CK1MD
Timer 2	Count clock	CK2MD
Timer 3	Count clock	CK3MD
Timer 4	Count clock	CK4MD
Serial 0	Transfer clock	SC0CKS
Serial 1	Transfer clock	SC1CKS
Serial 2	Transfer clock	SC2CKS
Serial 3	Transfer clock	SC3CKS
D/A conversion	D/A conversion base clock	-



When the prescaler output clock source is used, counting of prescaler should be enabled before starting the peripheral functions.

## 5-3-2 Setup Example

### ■ Prescaler Setup Example (Timer 0 count clock)

Select the clock of fosc/16 that is output from the prescaler 0, to the count clock of the timer 0.

An example setup procedure, with a description of each step is shown below.

Setup Procedure	Description
(1) Select the prescaler output. CK0MD (x'3F56') bp2-1 : TM0PSC1-0 = 01 bp0 : TM0BAS = 0 (2) Enable the prescaler output. PSCMD (x'3F6F') bp0 : PSCEN = 1	(1) Select the prescaler output to fosc/16 by the TM0PSC1-0, TM0BAS flag of the timer 0 prescaler selection register (CK0MD). (2) Enable the prescaler counting by setting the PSCEN flag of the prescaler control register (PSCMD) to "1".

Enable the prescaler counting by the PSCEN flag of the prescaler control register (PSCMD). The prescaler counting is started after it is enabled.

Start the timer operation after the prescaler is set. Also, the selection of the prescaler output should be set by the timer mode register.



## Chapter 6 8-bit Timers

## 6-1 Overview

This LSI contains three general purpose 8-bit timers (Timers 0, 1 and 3) and two 8-bit timers (Timers 2 and 4) that can be also used as baud rate timer. The general purpose 8-bit timers can be used as 16-bit timers with cascade connection.


In a cascade connection, timers 0, 2 and 4 form the "timer 0", or the lower 8 bits of 16-bit counter, and timers 1 and 3 form the "timer 1", or the upper 8 bits. Timer 4 cannot be cascaded.

Fosc or fs can be selected as the clock source for each timer by using the prescaler. Also, remote control output circuit is built in.

### 6-1-1 Functions

Table 6-1-1 shows functions of each timer.

**Table 6-1-1 Timer Functions**

	Timer 0 (8 bit)	Timer 1 (8 bit)	Timer 2 (8 bit)	Timer 3 (8 bit)	Timer 4 (8 bit)
Interrupt source	TM0IRQ	TM1IRQ	TM2IRQ	TM3IRQ	TM4IRQ
Timer operation	√	√	√	√	√
Event count	√	√	√	√	√
Timer pulse output	√	√	√	√	√
PWM output	√	-	√	-	√
Synchronous output	-	√	√	-	-
Serial transfer clock output	-	-	√	√	√
Pulse width measurement	√	-	√	-	√
Cascade connection	√		√		-
Remote control carrier output	√	-	-	√	-
Clock source	fosc fosc/4 fosc/16 fosc/32 fosc/64 fs/2 fs/4 fx TM0IO input	fosc fosc/4 fosc/16 fosc/64 fosc/128 fs/2 fs/8 fx TM1IO input	fosc fosc/4 fosc/16 fosc/32 fosc/64 fs/2 fs/4 fx TM2IO input	fosc fosc/4 fosc/16 fosc/64 fosc/128 fs/2 fs/8 fx TM3IO input	fosc fosc/4 fosc/16 fosc/32 fosc/64 fs/2 fs/4 fx TM4IO input
fosc : Machine clock (High speed oscillation ) fx : Machine clock (Low speed oscillation ) fs : System clock [  Chapter 2 2-5 Clock Switching ] - When timers 2 and 4 are used as a baud rate timer for serial interface I function, it is not used as a general timer.					





■ Timers 2 and 3 Block Diagram

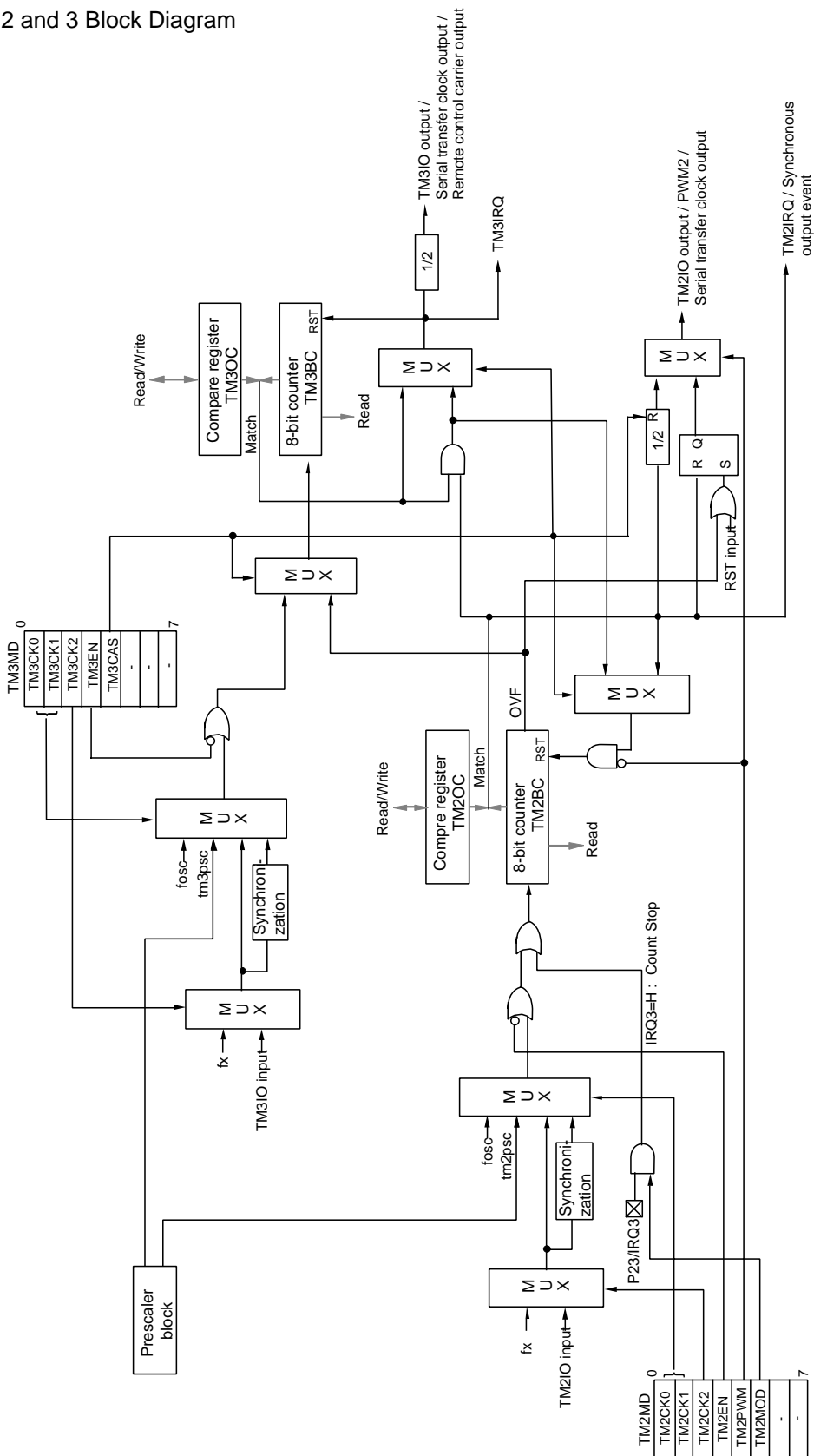


Figure 6-1-2 Timers 2 and 3 Block Diagram

■ Timer 4 Block Diagram

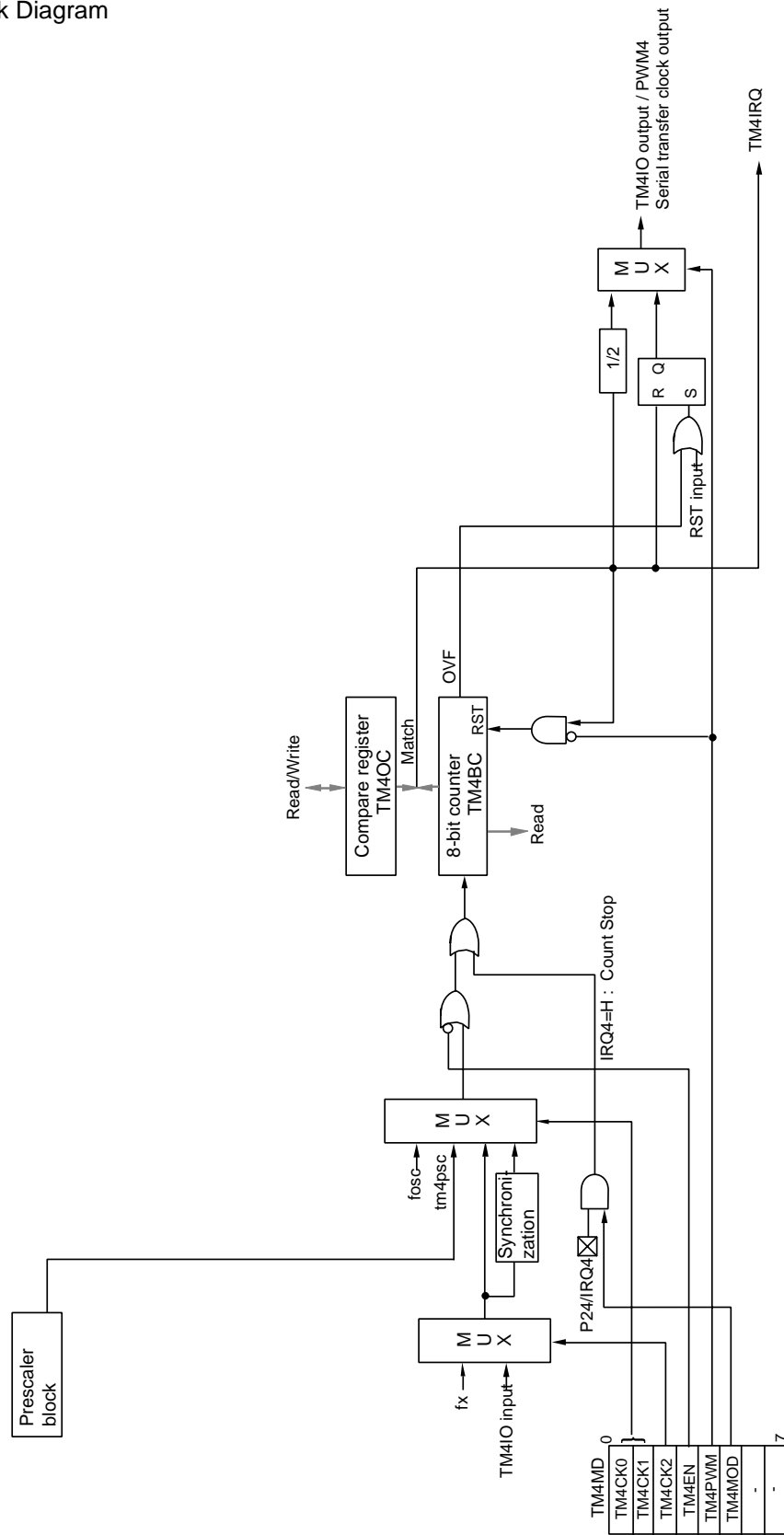


Figure 6-1-3 Timer 4 Block Diagram

■ Remote Control Carrier Output Block Diagram

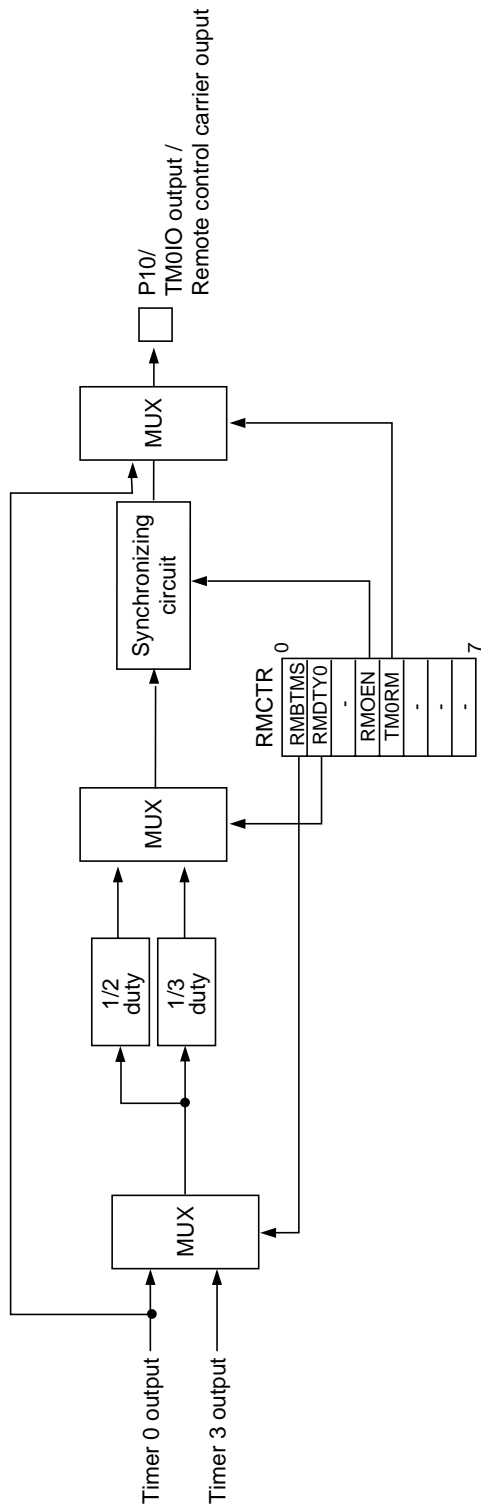


Figure 6-1-4 Remote Control Carrier Output Block Diagram

## 6-2 Control Registers

Timers 0 to 4 consist of the binary counter (TMnBC) and the compare register (TMnOC). And they are controlled by the mode register (TMnMD).

When the prescaler output is selected as the count clock source of timers 0 to 4, they should be controlled by the prescaler control register (PSCMD) and the prescaler selection register (CKnMD). Remote control carrier output is controlled by the remote control carrier output control register (RMCTR).

### 6-2-1 Registers

Table 6-2-1 shows registers that control timers 0 to 4 and remote control carrier output

**Table 6-2-1 8-bit Timer Control Registers**

	Register	Address	R/W	Function	Page
Timer 0	TM0BC	x'03F50'	R	Timer 0 binary counter	VI-10
	TM0OC	x'03F52'	R/W	Timer 0 compare register	VI-9
	TM0MD	x'03F54'	R/W	Timer 0 mode register	VI-11
	CK0MD	x'03F56'	R/W	Timer 0 prescaler selection register	V-7
	PSCMD	x'03F6F'	R/W	Prescaler control register	V-6
	TM0ICR	x'03FE9'	R/W	Timer 0 interrupt control register	III-24
	P1OMD	x'03F2F'	R/W	Port 1 output mode register	IV-15
	P1DIR	x'03F31'	R/W	Port 1 direction control register	IV-14
Timer 1	TM1BC	x'03F51'	R	Timer 1 binary counter	VI-10
	TM1OC	x'03F53'	R/W	Timer 1 compare register	VI-9
	TM1MD	x'03F55'	R/W	Timer 1 mode register	VI-12
	CK1MD	x'03F57'	R/W	Timer 1 prescaler selection register	V-7
	PSCMD	x'03F6F'	R/W	Prescaler control register	V-6
	TM1ICR	x'03FEA'	R/W	Timer 1 interrupt control register	III-25
	P1OMD	x'03F2F'	R/W	Port 1 output mode register	IV-15
	P1DIR	x'03F31'	R/W	Port 1 direction control register	IV-14
Timer 2	TM2BC	x'03F58'	R	Timer 2 binary counter	VI-10
	TM2OC	x'03F5A'	R/W	Timer 2 compare register	VI-9
	TM2MD	x'03F5C'	R/W	Timer 2 mode register	VI-13
	CK2MD	x'03F5E'	R/W	Timer 2 prescaler selection register	V-8
	PSCMD	x'03F6F'	R/W	Prescaler control register	V-6
	TM2ICR	x'03FEB'	R/W	Timer 2 interrupt control register	III-26
	P1OMD	x'03F2F'	R/W	Port 1 output mode register	IV-15
	P1DIR	x'03F31'	R/W	Port 1 direction control register	IV-14

	Register	Address	R/W	Function	Page
Timer 3	TM3BC	x'03F59'	R	Timer 3 binary counter	VI-10
	TM3OC	x'03F5B'	R/W	Timer 3 compare register	VI-9
	TM3MD	x'03F5D'	R/W	Timer 3 mode register	VI-14
	CK3MD	x'03F5F'	R/W	Timer 3 prescaler selection register	V-8
	PSCMD	x'03F6F'	R/W	Prescaler control register	V-6
	TM3ICR	x'03FEC'	R/W	Timer 3 interrupt control register	III-27
	P1OMD	x'03F2F'	R/W	Port 1 output mode register	IV-15
	P1DIR	x'03F31'	R/W	Port 1 direction control register	IV-14
Timer 4	TM4BC	x'03F60'	R	Timer 4 binary counter	VI-10
	TM4OC	x'03F62'	R/W	Timer 4 compare register	VI-9
	TM4MD	x'03F64'	R/W	Timer 4 mode register	VI-15
	CK4MD	x'03F66'	R/W	Timer 4 prescaler selection register	V-9
	PSCMD	x'03F6F'	R/W	Prescaler control register	V-6
	TM4ICR	x'03FED'	R/W	Timer 4 interrupt control register	III-28
	P1OMD	x'03F2F'	R/W	Port 1 output mode register	IV-15
	P1DIR	x'03F31'	R/W	Port 1 direction control register	IV-14
Remote control carrier output	RMCTR	x'03F6E'	R/W	Remote control carrier output control register	VI-16

R/W : Readable / Writable

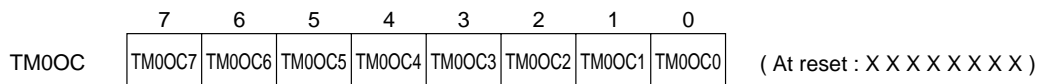
R : Readable only

## 6-2-2 Programmable Timer Registers

Each of timers 0 to 4 has 8-bit programmable timer registers. Programmable timer register consists of compare register and binary counter.

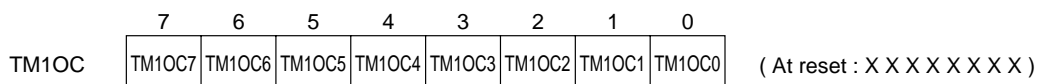
Compare register is 8-bit register which stores the value to be compared to binary counter.

### ■Timer 0 Compare Register (TM0OC)



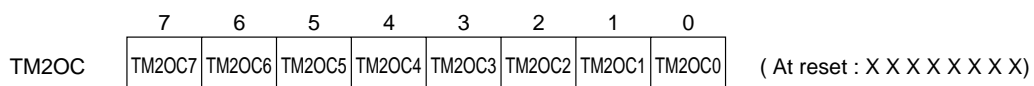
**Figure 6-2-1 Timer 0 Compare Register (TM0OC : x'03F52', R/W)**

### ■Timer 1 Compare Register (TM1OC)



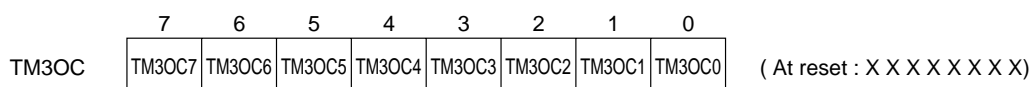
**Figure 6-2-2 Timer 1 Compare Register (TM1OC : x'03F53', R/W)**

### ■Timer 2 Compare Register (TM2OC)



**Figure 6-2-3 Timer 2 Compare Register (TM2OC : x'03F5A', R/W)**

### ■Timer 3 Compare Register (TM3OC)



**Figure 6-2-4 Timer 3 Compare Register (TM3OC : x'03F5B', R/W)**

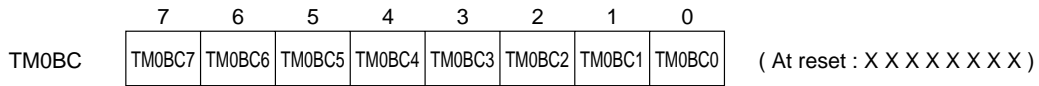
### ■Timer 4 Compare Register (TM4OC)



**Figure 6-2-5 Timer 4 Compare Register (TM4OC : x'03F62', R/W)**

Binary counter is 8-bit up counter. If any data is written to compare register during counting is stopped, binary counter is cleared to x'00'.

■Timer 0 Binary Counter (TM0BC)



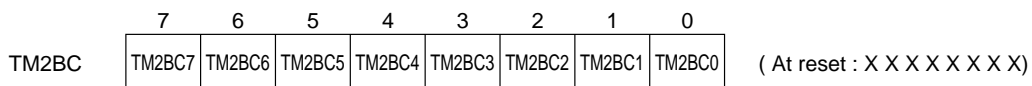
**Figure 6-2-6 Timer 0 Binary Counter (TM0BC : x'03F50', R)**

■Timer 1 Binary Counter (TM1BC)



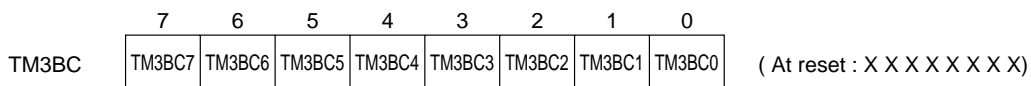
**Figure 6-2-7 Timer 1 Binary Counter (TM1BC : x'03F51', R)**

■Timer 2 Binary Counter (TM2BC)



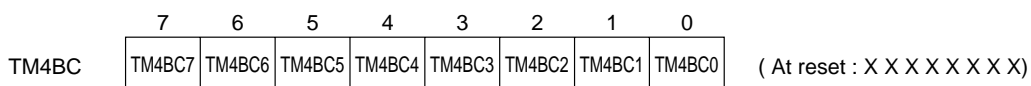
**Figure 6-2-8 Timer 2 Binary Counter (TM2BC : x'03F58', R)**

■Timer 3 Binary Counter (TM3BC)



**Figure 6-2-9 Timer 3 Binary Counter (TM3BC : x'03F59', R)**

■Timer 4 Binary Counter (TM4BC)



**Figure 6-2-10 Timer 4 Binary Counter (TM4BC : x'03F60', R)**



### 6-2-3 Timer Mode Registers

Timer mode register is readable/writable register that controls timers 0 to 4.

■Timer 0 Mode Register (TM0MD)

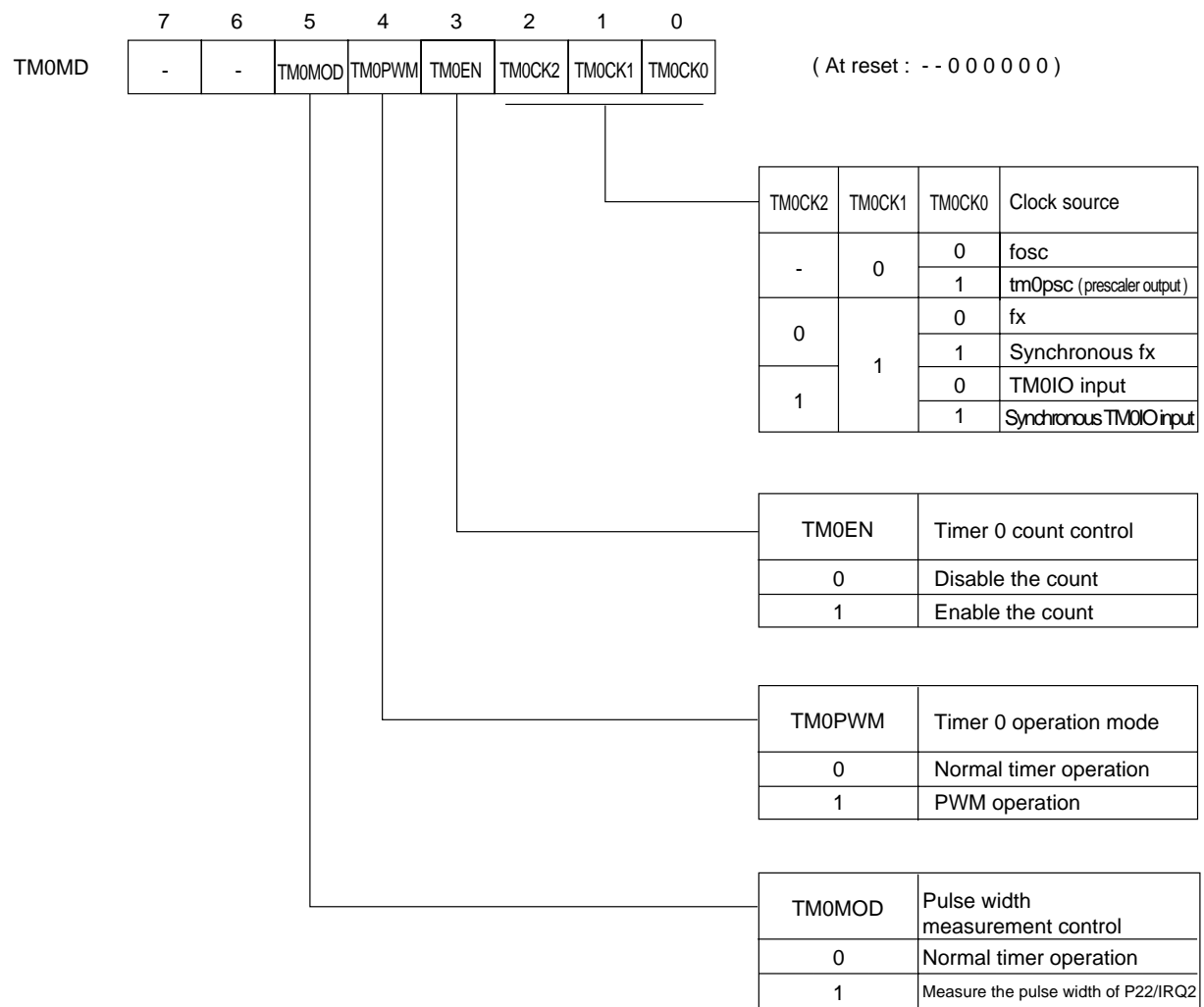


Figure 6-2-11 Timer 0 Mode Register (TM0MD : x'03F54', R/W)

■Timer 1 Mode Register (TM1MD)

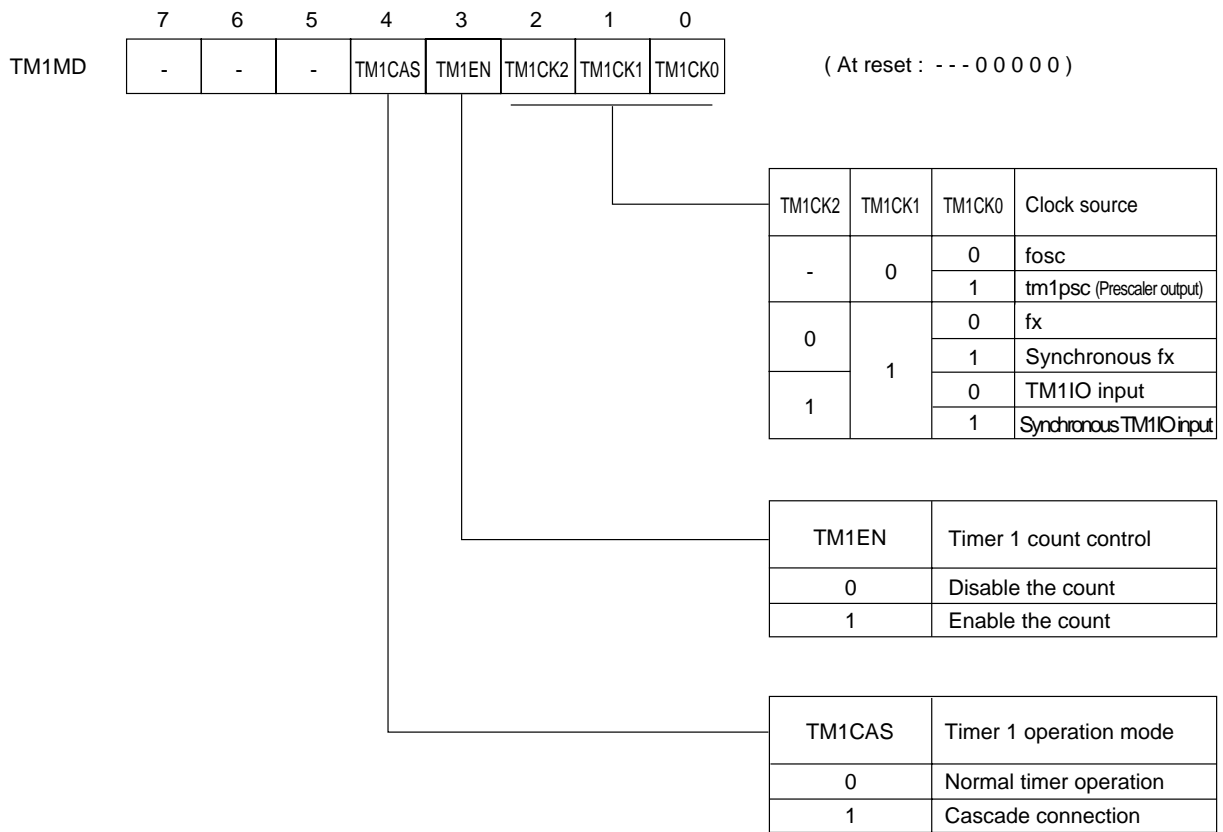


Figure 6-2-12 Timer 1 Mode Register (TM1MD : x'03F55', R/W)

■ Timer 2 Mode Register (TM2MD)

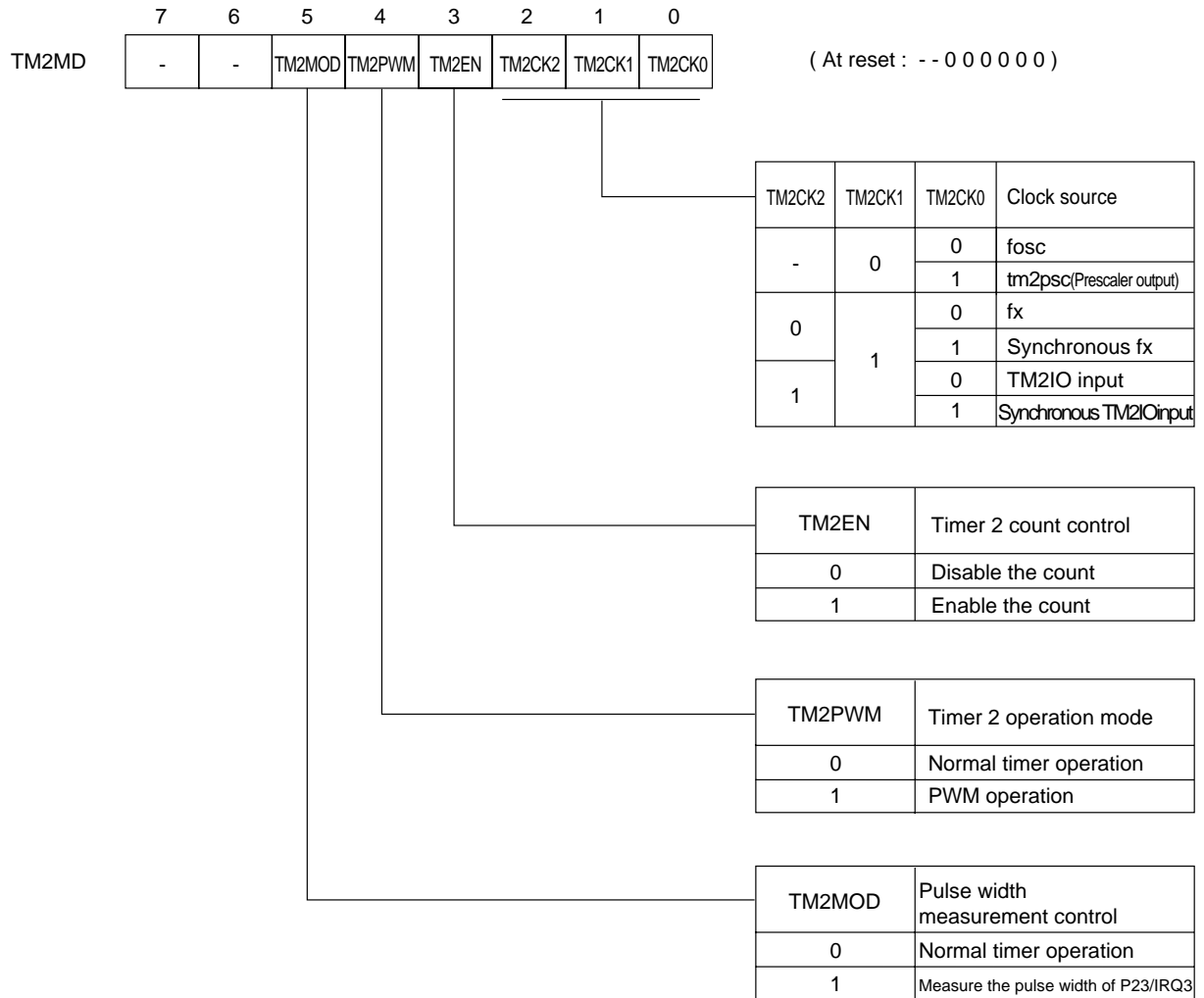


Figure 6-2-13 Timer 2 Mode Register (TM2MD : x'03F5C', R/W)

■ Timer 3 Mode Register (TM3MD)

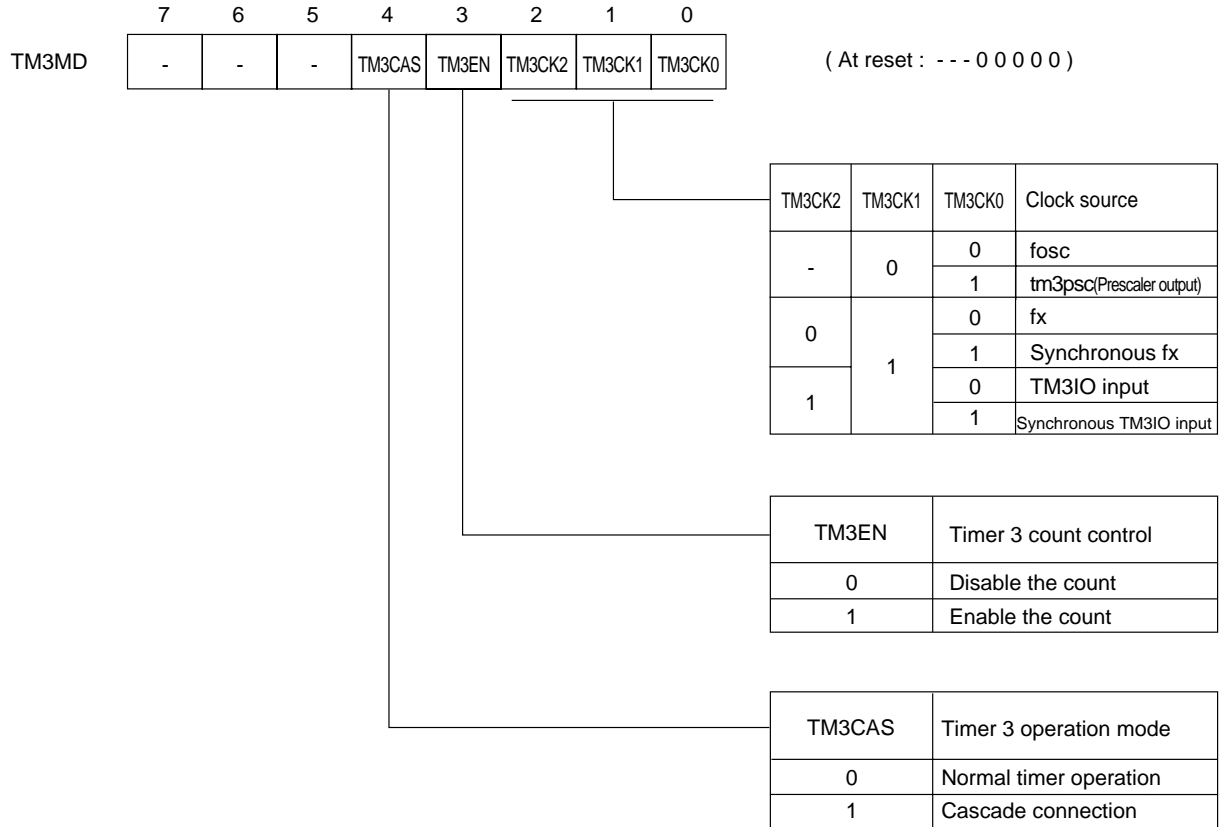


Figure 6-2-14 Timer 3 Mode Register (TM3MD : x'03F5D', R/W)

■Timer 4 Mode Register (TM4MD)

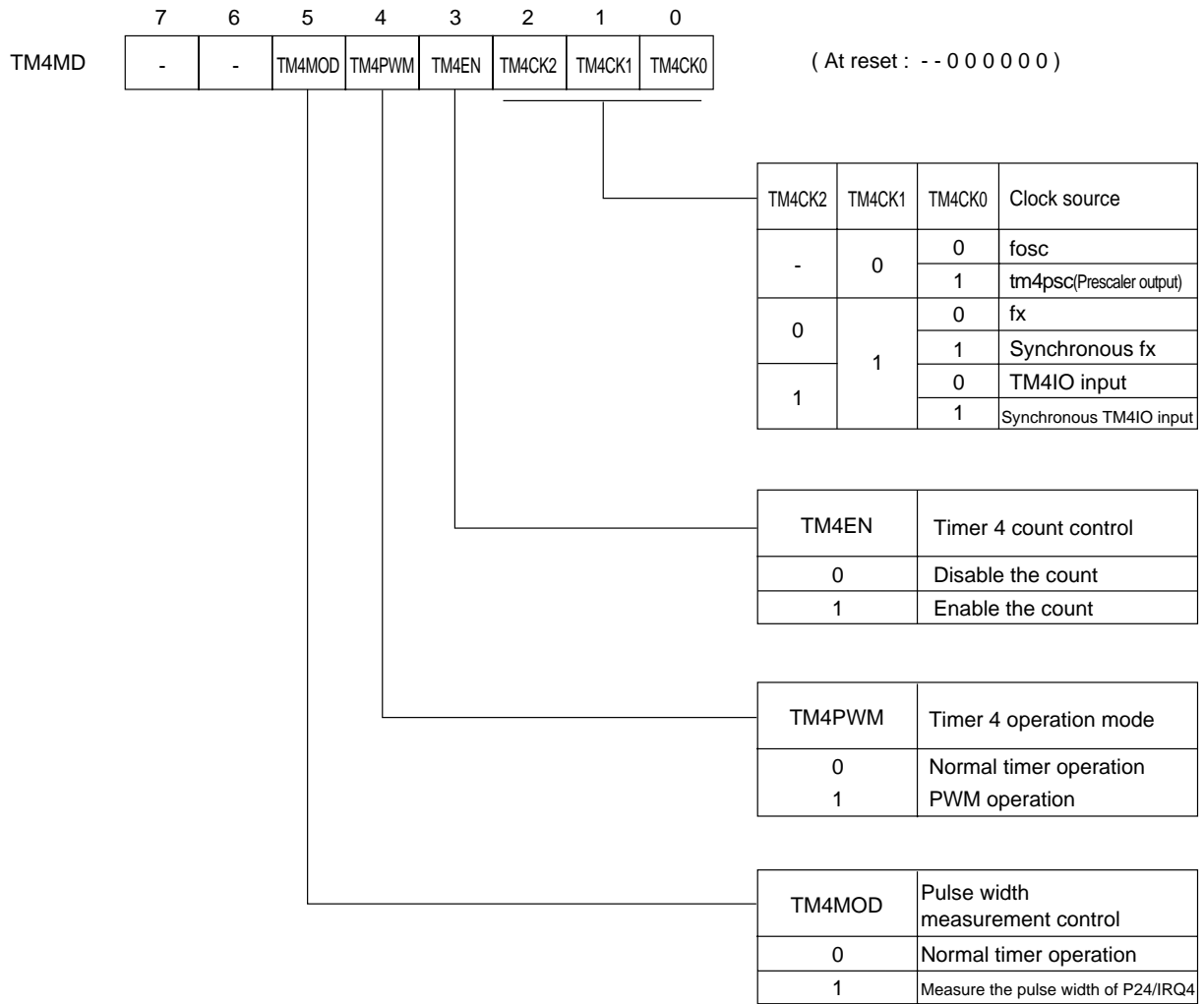


Figure 6-2-15 Timer 4 Mode Register (TM4MD : x'03F64', R/W)

■ Remote Control Carrier Output Control Register (RMCTR)

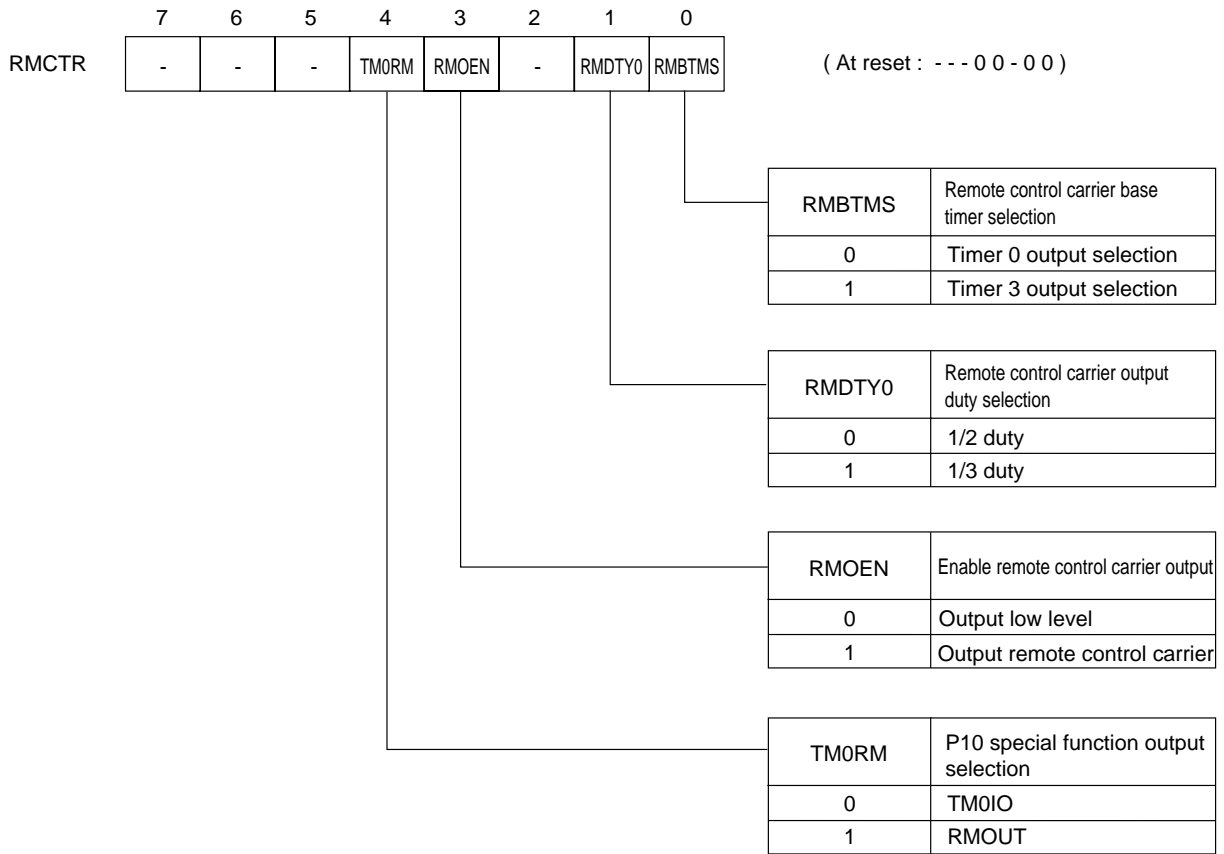


Figure 6-2-16 Remote Control Carrier Output Control Register (RMCTR : x'03F6E', R/W)

## 6-3 8-bit Timer Count

### 6-3-1 Operation

The timer operation can constantly generate interrupts.

#### ■8-bit Timer Operation (Timers 0, 1, 2, 3 and 4)

The generation cycle of timer interrupts is set by the clock source selection and the setting value of the compare register (TMnOC), in advance. If the binary counter (TMnBC) reaches the setting value of the compare register, an interrupt is generated at the next count clock, then binary counter is cleared and counting is restarted from x'00'.

Table 6-3-1 shows clock source that can be selected.

**Table 6-3-1 Clock Source (Timers 0, 1, 2, 3 and 4) at Timer Operation**

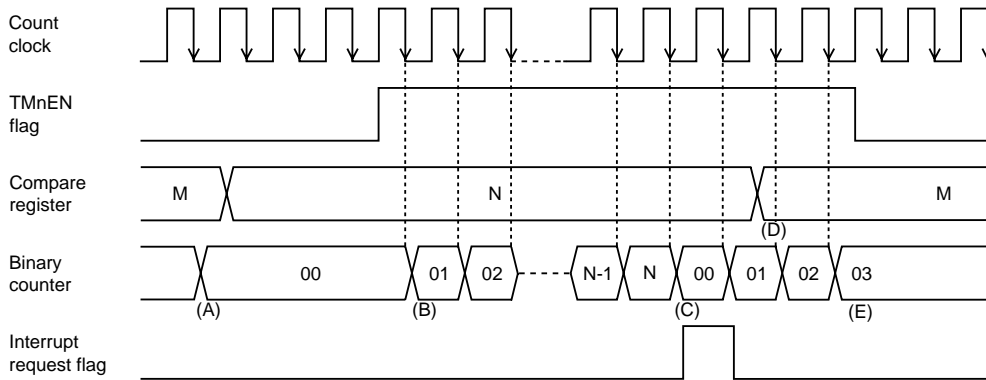
Clock source	1 count time	Timer 0 (8 Bit)	Timer 1 (8 Bit)	Timer 2 (8 Bit)	Timer 3 (8 Bit)	Timer 4 (8 Bit)
fosc	50 ns	√	√	√	√	√
fosc/4	200 ns	√	√	√	√	√
fosc/16	800 ns	√	√	√	√	√
fosc/32	1.6 μs	√	-	√	-	√
fosc/64	3.2 μs	√	√	√	√	√
fosc/128	6.4 μs	-	√	-	√	-
fs/2	200 ns	√	√	√	√	√
fs/4	400 ns	√	-	√	-	√
fs/8	800 ns	-	√	-	√	-
fx	30.5 μs	√	√	√	√	√

Notes : as fosc = 20 MHz   fx = 32.768 kHz   fs = fosc/2 = 10 MHz

■ Count Timing of Timer Operation (Timers 0, 1, 2, 3 and 4)





Binary counter counts up with selected clock source as a count clock.

The basic operation of the whole function of 8-bit timer is as follows ;



**Figure 6-3-1 Count Timing of Timer Operation (Timers 0, 1, 2, 3 and 4)**

- (A) If the value is written to the compare register during the TMnEN flag is "0", the binary counter is cleared to x'00', at the writing cycle.
- (B) If the TMnEN flag is "1", the binary counter is started to count. The counter starts to count up at the falling edge of the count clock.
- (C) If the binary counter reaches the value of the compare register, the interrupt request flag is set at the next count clock, then the binary counter is cleared to x'00' and the counting is restarted.
- (D) Even if the compare register is rewritten during the TMnEN flag is "1", the binary counter is not changed.
- (E) If the TMnEN flag is "0", the binary counter is stopped.

	When the binary counter reaches the value in the compare register, the interrupt request flag is set and the binary counter is cleared, at the next count clock. So set the compare register as: Compare register setting = (count till the interrupt request - 1)
	If the compare register is set the smaller than the binary counter during the count operation, the binary counter counts up to the overflow, at first.
	If the interrupt is enabled, the timer interrupt request flag should be cleared before timer operation is started.
	The timer n interrupt request generation (at TMnOC = x'00') has the same waveform at TMnOC = x'01'.




## 6-3-2 Setup Example

### ■Timer Operation Setup Example (Timers 0, 1, 2, 3 and 4)

Timer function can be set by using timer 0 that generates the constant interrupt. By selecting  $f_s/4$  (at  $f_{osc} = 20$  MHz) as a clock source, interrupt is generated every 250 clock cycles (100  $\mu$ s).

An example setup procedure, with a description of each step is shown below.

Setup Procedure	Description
(1) Stop the counter. TM0MD (x'3F54') bp3 :TM0EN = 0	(1) Set the TM0EN flag of the timer 0 mode register (TM0MD) to "0" to stop the counting of timer 0.
(2) Select the normal timer operation. TM0MD (x'3F54') bp4 :TM0PWM = 0 bp5 :TM0MOD = 0	(2) Set the TM0PWM flag and TM0MOD flag of the TM0MD register to "0" to select the normal timer operation.
(3) Select the count clock source. TM0MD (x'3F54') bp2-0 :TM0CK2-0 = 001	(3) Select the prescaler output to the clock source by the TM0CK2-0 flag of the TM0MD register.
(4) Select the prescaler output and enable the counting. CK0MD (x'3F56') bp2-1 :TM0PSC1-0 = 01 bp0 :TM0BAS = 1 PSCMD (x'3F6F') bp0 :PSCEN = 1	(4) Select $f_s/4$ to the prescaler output by the TM0PSC1-0, TM0BAS flag of the timer 0 prescaler selection register (CK0MD). Also, set the PSCEN flag of the prescaler control register (PSCMD) to "1" to enable the counting of the prescaler.
(5) Set the cycle of the interrupt generation. TM0OC (x'3F52') = x'F9'	(5) Set the value of the interrupt generation cycle to the timer 0 compare register (TM0OC). The cycle is 250, so that the setting value is set to 249 (x'F9'). At that time, the timer 0 binary counter (TM0BC) is initialized to x'00'.
(6) Set the interrupt level. TM0ICR (x'3FE9') bp7-6 :TM0LV1-0 = 10	(6) Set the interrupt level by the TM0LV1-0 flag of the timer 0 interrupt control register (TM0ICR). If the interrupt request flag may be already set, clear the request flag. [  Chapter 3 3-1-4. Interrupt flag setting ]

Setup Procedure	Description
(7) Enable the interrupt. TM0ICR (x'3FE9') bp1 :TMOIE = 1	(7) Set the TMOIE flag of the TM0ICR register to "1" to enable the interrupt.
(8) Start the timer operation. TM0MD (x'3F54') bp3 :TMOEN = 1	(8) Set the TMOEN flag of the TM0MD register to "1" to start the timer 0.

The TM0BC starts to count up from 'x00'. When the TM0BC reaches the setting value of the TM0OC register, the timer 0 interrupt request flag is set at the next count clock, then the value of the TM0BC becomes 'x00' and restart to count up.



When the TMnEN flag of the TMnMD register is changed at the same time to other bit, binary counter may start to count up by the switching operation.



If fx is selected as the count clock source, when the binary counter is read at operation, uncertain value on counting up may be read. To prevent this, select the synchronous fx as the count clock source.

In this case the timer n counter counts up in synchronization with system clock, therefore the correct value is always read.

But, if the synchronous fx is selected as the count clock source, CPU mode cannot return from STOP/HALT mode.

## 6-4 8-bit Event Count

### 6-4-1 Operation

Event count operation has 2 types ; TMnIO input and synchronous TMnIO input can be selected as the count clock.

#### ■8-bit Event Count Operation

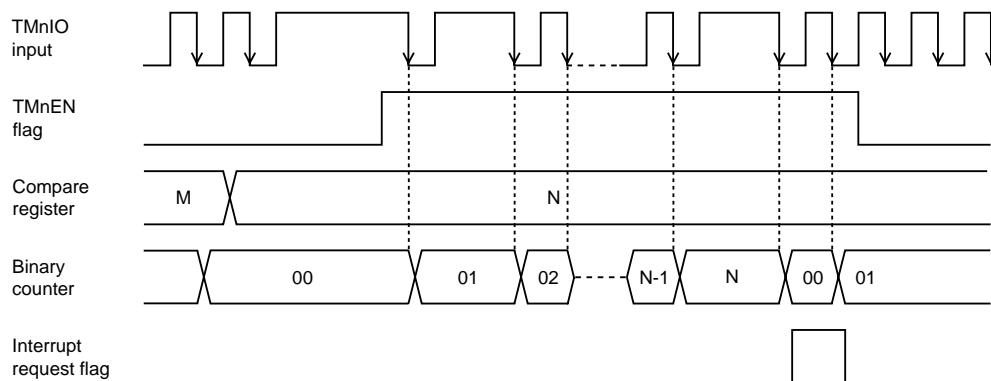
Event count means that the binary counter (TMnBC) counts the input signal from external to the TMnIO pin. If the value of the binary counter reaches the setting value of the compare register (TMnOC), interrupts can be generated at the next count clock.

**Table 6-4-1 Event Count Input Clock**

	Timer 0	Timer 1	Timer 2	Timer 3	Timer 4
Event input	TM0IO input ( P10 )	TM1IO input ( P11 )	TM2IO input ( P12 )	TM3IO input ( P13 )	TM4IO input ( P16 )
	Synchronous TM0IO input	Synchronous TM1IO input	Synchronous TM2IO input	Synchronous TM3IO input	Synchronous TM4IO input

#### ■Count Timing of TMnIO Input (Timers 0, 1, 2, 3 and 4)

When TMnIO input is selected, TMnIO input signal is directly input to the count clock of the timer n. The binary counter counts up at the falling edge of the TMnIO input signal.



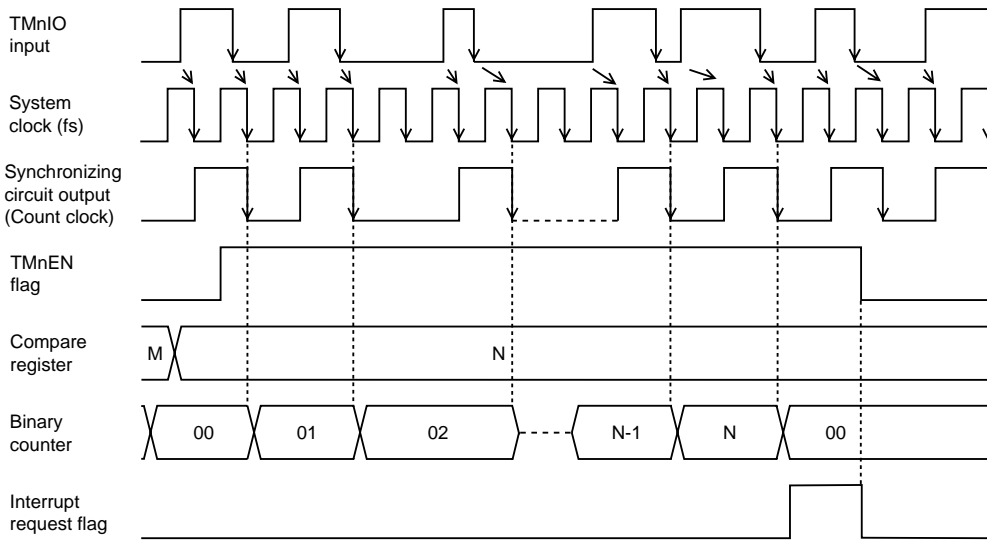
**Figure 6-4-1 Count Timing of TMnIO Input (Timers 0 to 4)**



When the TMnIO input is selected for count clock source and the value of the timer n binary counter is read during operation, incorrect value at count up may be read out. To prevent this, use the event count by synchronous TMnIO input, as the following page.

■ Count Timing of Synchronous TMnIO Input (Timers 0, 1, 2, 3 and 4)

If the synchronous TMnIO input is selected, the synchronizing circuit output signal is input to the timer n count clock. The synchronizing circuit output signal is changed at the falling edge of the system clock after TMnIO input signal is changed.



**Figure 6-4-2 Count Timing of Synchronous TMnIO Input (Timers 0 to 4)**



When the synchronous TMnIO input is selected as the count clock source, the timer n counter counts up in synchronization with system clock, therefore the correct value is always read.



But, if the synchronous TMnIO is selected as the count clock source, CPU mode cannot return from STOP/HALT mode.

## 6-4-2 Setup Example

### ■Event Count Setup Example (Timers 0, 1, 2, 3 and 4)

If the falling edge of the TM0IO input pin signal is detected 5 times with using timer 0, an interrupt is generated.

An example setup procedure, with a description of each step is shown below.

Setup Procedure	Description
(1) Stop the counter. TM0MD (x'3F54') bp3 :TM0EN = 0	(1) Set the TM0EN flag of the timer 0 mode register (TM0MD) to "0" to stop timer 0 counting.
(2) Set the special function pin to input. P1DIR (x'3F31') bp0 :P1DIR0 = 0	(2) Set the P1DIR0 flag of the port 1 direction control register (P1DIR) to "0" to set P10 pin to input mode.  If it needs, pull up resistor should be added. [  Chapter 4. I/O Ports ]
(3) Select the normal timer operation. TM0MD (x'3F54') bp4 :TM0PWM = 0 bp5 :TM0MOD = 0	(3) Set the TM0PWM flag and TM0MOD flag of the TM0MD register to "0" to select the normal timer operation.
(4) Select the count clock source. TM0MD (x'3F54') bp2-0 :TM0CK2-0 = 110	(4) Select the clock source to TM0IO input by the TM0CK2-0 flag of the TM0MD register.
(5) Set the interrupt generation cycle. TM0OC (x'3F52') = x'04'	(5) Set the timer 0 compare register (TM0OC) the interrupt generation cycle. Counting is 5, so the setting value should be 4. At that time, the timer 0 binary counter (TM0BC) is initialized to x'00'.
(6) Set the interrupt level. TM0ICR (x'3FE9') bp7-6 :TM0LV1-0 = 10	(6) Set the interrupt level by the TM0LV1-0 flag of the timer 0 interrupt control register (TM0ICR). If the interrupt request flag may be already set, cancel all existing interrupt requests. [  Chapter 3 3-1-4. Interrupt Flag Setup ]

Setup Procedure	Description
(7) Enable the interrupt. TM0ICR (x'3FE9') bp1      :TM0IE      = 1	(7) Set the TM0IE flag of the TM0ICR register to "1" to enable the interrupt.
(8) Start the event counting. TM0MD (x'3F54') bp3      :TM0EN      = 1	(8) Set the TM0EN flag of the TM0MD register to start timer 0.

Every time TM0BC detects the falling edge of TM0IO input , TM0BC counts up from 'x00'. When TM0BC reaches the setting value of theTM0OC register, the timer 0 interrupt request flag is set at the next count clock, then the value of TM0BC becomes x'00' and counting up is restarted.

## 6-5 8-bit Timer Pulse Output

### 6-5-1 Operation

The TMnIO pin can output a pulse signal with any cycle.

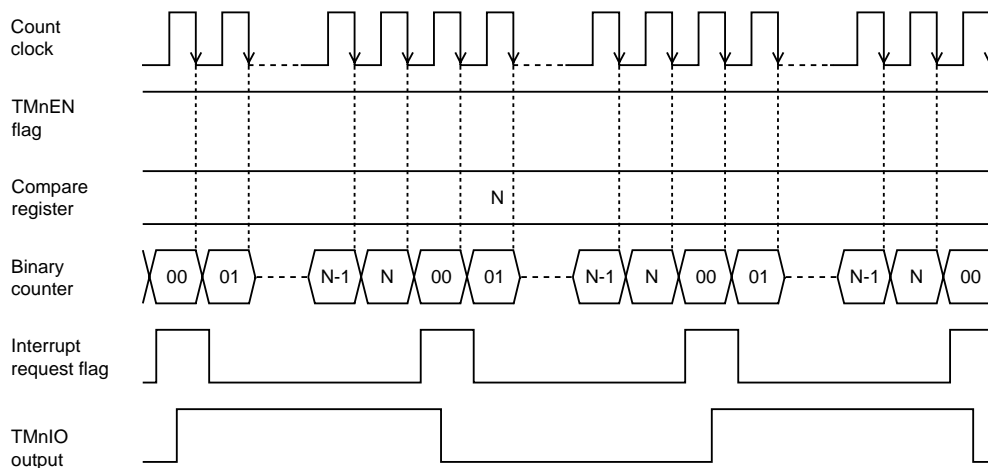
■ Operation of Timer Pulse Output (Timers 0, 1, 2, 3 and 4)

The timers can output 2 x cycle signal, compared to the setting value in compare register (TMnOC). Output pins are as follows ;

**Table 6-5-1 Timer Pulse Output Pins**

	Timer 0	Timer 1	Timer 2	Timer 3	Timer 4
Pulse output pin	TM0IO output (P10)	TM1IO output (P11)	TM2IO output (P12)	TM3IO output (P13)	TM4IO output (P16)

■ Count Timing of Timer Pulse Output (Timers 0, 1, 2, 3 and 4)



**Figure 6-5-1 Count Timing of Timer Pulse Output (Timers 0 to 4)**


The TMnIO pin outputs 2 x cycle, compared to the value in the compare register. If the binary counter reaches the compare register, and the binary counter is cleared to x'00', TMnIO output is inverted. The inversion of the timer output is changed at the rising edge of the count clock. This is happened to form waveform inside to correct the output cycle.

## 6-5-2 Setup Example

### ■Timer Pulse Output Setup Example (Timers 0, 1, 2, 3 and 4)

TM0IO pin outputs 50 kHz pulse by using timer 0. For this, select fosc as clock source, and set a 1/2 cycle (100 kHz) for the timer 0 compare register (at fosc=20 MHz).

An example setup procedure, with a description of each step is shown below.

Setup Procedure	Description
(1) Stop the counter. TM0MD (x'3F54') bp3       :TM0EN     = 0	(1) Set the TM0EN flag of the timer 0 mode register (TM0MD) to "0" to stop timer 0 counting.
(2) Set the special function pin to the output mode. P1OMD (x'3F2F') bp0       :P1OMD0   = 1 P1DIR (x'3F31') bp0       :P1DIR0   = 1	(2) Set the P1OMD0 flag of the port 1 output mode register (P1OMD) to "1" to set P10 the special function pin. Set the P1DIR0 flag of the port 1 direction control register (P1DIR) to "1" to set output mode. If it needs, pull-up resistor should be added. [  Chapter 4. I/O Ports ]
(3) Select the normal timer operation. TM0MD (x'3F54') bp4       :TM0PWM   = 0 bp5       :TM0MOD   = 0	(3) Set the TM0PWM flag and TM0MOD flag of the TM0MD register to "0" to select the normal timer operation.
(4) Select the count clock source. TM0MD (x'3F54') bp2-0     :TM0CK2-0 = 000	(4) Select fosc for the clock source by the TM0CK2-0 flag of the TM0MD register.
(5) Set the timer pulse output cycle. TM0OC (x'3F52')       = x'C7'	(5) Set the timer 0 compare register (TM0OC) to the 1/2 of the timer pulse output cycle. The setting value should be $200-1=199(x'C7')$ , because 100 kHz is divided by 20 MHz. At that time, the timer 0 binary counter (TM0BC) is initialized to x'00'.
(6) Start the timer operation. TM0MD (x'3F54') bp3       :TM0EN     = 1	(6) Set the TM0EN flag of the TM0MD register to "1" to start timer 0.



TM0BC counts up from x'00'. If TM0BC reaches the setting value of the TM0OC register, then TM0BC is cleared to x'00', TM0IO output signal is inverted and TM0BC restarts to count up from x'00'.



At TMnOC = x'00', timer pulse output has the same waveform to at x'01'.



If any data is written to compare register binary counter is stopped, timer output is reset to "L".



Set the compare register value as follows.

The compare register value =  $\frac{\text{The timer pulse output cycle}}{\text{The count clock cycle} \times 2} - 1$

## 6-6 8-bit PWM Output

The TMnIO pin outputs the PWM waveform, which is determined by the match timing for the compare register and the overflow timing of the binary counter.

### 6-6-1 Operation

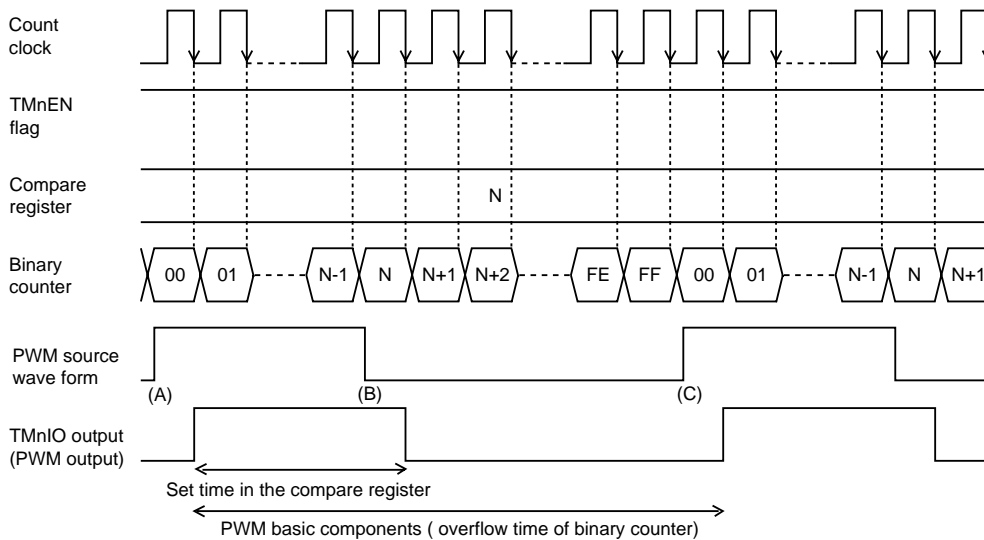
■ Operation of 8-bit PWM Output (Timers 0, 2 and 4)

The PWM waveform with any duty cycle is generated by setting the duty cycle of PWM "H" period to the compare register (TMnOC). The cycle is the period from the full count to the overflow of the 8-bit timer. Table 6-6-1 shows PWM output pins ;

**Table 6-6-1 Output Pins of PWM Output**

	Timer 0	Timer 2	Timer 4
PWM output pin	TM0IO output pin (P10)	TM2IO output pin (P12)	TM4IO output pin (P16)

■ Count Timing of PWM Output (at normal) (Timers 0, 2 and 4)



**Figure 6-6-1 Count Timing of PWM Output (at Normal)**

PWM source waveform,

- (A) is "H" while counting up from x'00' to the value stored in the compare register.
- (B) is "L" after the match to the value in the compare register, then the binary counter continues counting up till the overflow.
- (C) is "H" again, if the binary counter overflow.

The PWM outputs the PWM source waveform with 1 count clock delay. This is happened, because the waveform is created inside to correct the output cycle.

■Count Timing of PWM Output (when the compare register is x'00') (Timers 0, 2 and 4)

Here is the count timing when the compare register is set to x'00' ;

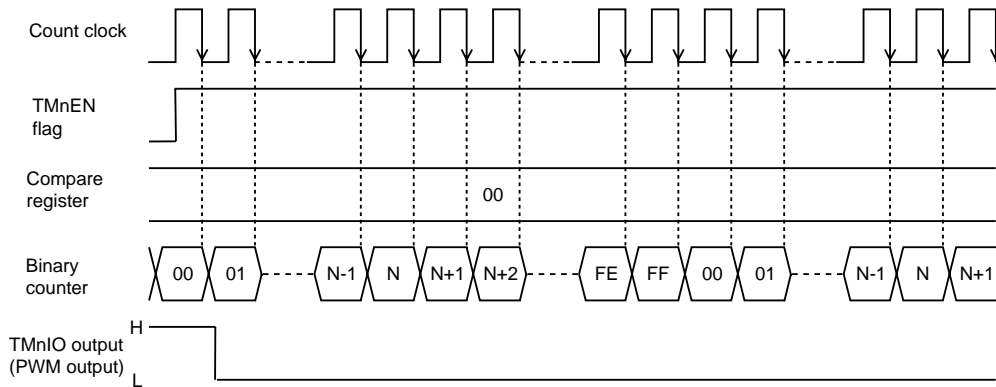


Figure 6-6-2 Count Timing of PWM Output (when compare register is x'00')

When TMnEN flag is stopped ("0") PWM output is "H".

■Count Timing of PWM Output (when the compare register is x'FF') (Timers 0, 2 and 4)

Here is the count timing when the compare register is set to x'FF' ;

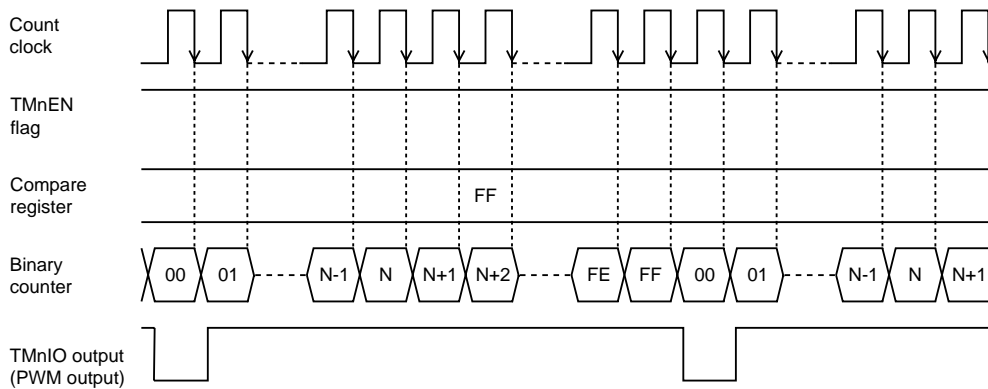


Figure 6-6-3 Count Timing of PWM Output (when compare register is x'FF')

## 6-6-2 Setup Example

### ■PWM Output Setup Example (Timers 0, 2 and 4)

The 1/4 duty cycle PWM output waveform is output from the TM0IO output pin at 128 Hz by using timer 0 (at  $f_x=32.768$  kHz). Cycle period of PWM output waveform is decided by the overflow of the binary counter. "H" period of the PWM output waveform is decided by the setting value of the compare register. An example setup procedure, with a description of each step is shown below.

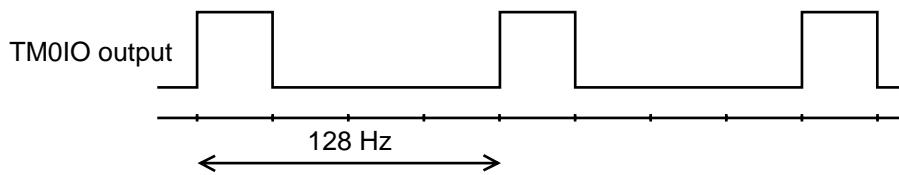



Figure 6-6-4 Output Waveform of TM0IO Output Pin

Setup Procedure	Description
(1) Stop the counter. TM0MD (x'3F54') bp3 :TM0EN = 0	(1) Set the TM0EN flag of the timer 0 mode register (TM0MD) to "0" to stop the timer 0 counting.
(2) Set the special function pin to the output mode. P1OMD (x'3F2F') bp0 :P1OMD0 = 1 P1DIR (x'3F31') bp0 :P1DIR0 = 1	(2) Set the P1OMD0 flag of the port 1 output mode register (P1OMD) to "1" to set P10 pin to the special function pin. Set the P1DIR0 flag of the port 1 direction control register (P1DIR) to "1" for the output mode. If it needs, pull up resistor should be added. [  Chapter 4. I/O Ports ]
(3) Select the PWM operation. TM0MD (x'3F54') bp4 :TM0PWM = 1 bp5 :TM0MOD = 0	(3) Set the TM0PWM flag of the TM0MD register to "1", the TM0MOD flag to "0" to select the PWM operation.
(4) Select the count clock source. TM0MD (x'3F54') bp2-0 :TM0CK2-0 = 010	(4) Select "fx" for the clock source by the TM0CK2-0 flag of the TM0MD register.

Setup Procedure	Description
(5) Set the period of PWM "H" output. $\text{TM0OC (x'3F52')} = \text{x'40'}$	(5) Set the "H" period of PWM output to the timer 0 compare register (TM0OC). The setting value is set to $256 / 4 = 64$ (x'40'), because it should be the 1/4 duty of the full count (256). At that time, the timer 0 binary counter (TM0BC) is initialized to x'00'.
(6) Start the timer operation. $\text{TM0MD (x'3F54')}$ $\text{bp3 :TM0EN} = 1$	(6) Set the TM0EN flag of the TM0MD register to "1" to operate timer 0.

TM0BC counts up from x'00'. PWM source waveform outputs "H" till TM0BC reaches the setting value of the TM0OC register, and outputs "L" after that. Then, TM0BC continues counting up, and PWM source waveform outputs "H" again, once overflow happens, and TM0BC restarts counting up from x'00'. TM0IO pin outputs the PWM source waveform with 1 count clock delay.



The initial setting of PWM output is changed from "L" output to "H" output at the selection of PWM operation by the TMnPWM flag of the TMnMD register.

## 6-7 8-bit Timer Synchronous Output

### 6-7-1 Operation

When the binary counter of the timer reaches the set value of the compare register, the latched data is output from port D at the next count clock.

#### ■ Synchronous Output Operation by 8-bit timer (Timer 1, Timer 2)

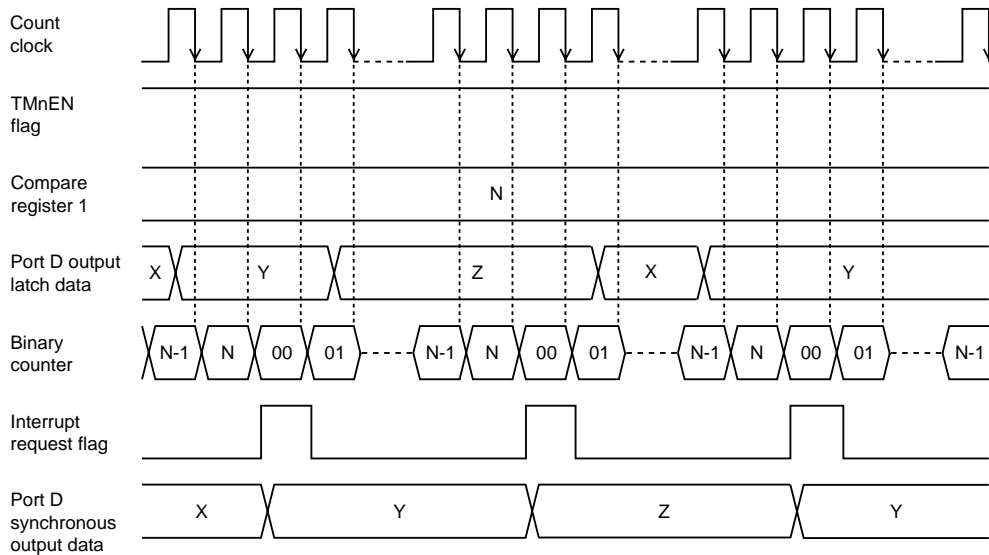
The port D latched data is output from the output pin at the interrupt request generation by the match of the binary counter and the compare register.

Only port D can perform synchronous output operation, and individual pins can be set. 8-bit timers that have synchronous output operation are timer 1 and timer 2.

**Table 6-7-1 Synchronous Output Port (Timer 1, Timer 2)**

	Timer 1	Timer 2
Synchronous output port	Port D	Port D

#### ■ Count Timing of Synchronous Output (Timer 1, Timer 2)



**Figure 6-7-1 Count Timing of Synchronous Output (Timer 1, Timer2)**


The port D latched data is output from the output pin in synchronization with the interrupt request generation by the match of binary counter and compare register.

## 6-7-2 Setup Example

### ■ Synchronous Output Setup Example (Timer 1, Timer 2)

Setup example that latch data of port D is output constantly (100  $\mu$ s) by using timer 2 from the synchronous output pin is shown below. The clock source of timer 2 is selected fs/4 (at fosc=8 MHz).

An example setup procedure, with a description of each step is shown below.

Setup Procedure	Description
(1) Start the counter. TM2MD (x'3F5C') bp3       :TM2EN     = 0	(1) Set the TM2EN flag of the timer 2 mode register (TM2MD) to "0" to stop the timer 2 counting.
(2) Select the synchronous output event. FLOAT (x'3F2E') bp1-0     :SYOEVS1-0 = 10	(2) Set the SYOEVS1-0 flag of the pin control register (FLOAT) to "10" to set the synchronous output event to timer 2 interrupt.
(3) Set the synchronous output pin. PDSYO (x'3F1F')         = x'FF' PDDIR (x'3F3D')         = x'FF'	(3) Set the port D synchronous output control register (PDSYO) to x'FF' to set the synchronous output pin. (PD7 to PD 0 are synchronous output pin.) Set the port D direction control register (PDDIR) to x'FF' to set port D to output mode. If it needs, pull up resistor should be added. [  Chapter 4. I/O Ports ]
(4) Select the normal timer operation. TM2MD (x'3F5C') bp4       :TM2PWM   = 0 bp5       :TM2MOD   = 0	(4) Set the TM2PWM flag and TM2MOD flag of the TM2MD register to "0" to select the normal timer operation.
(5) Select the count clock source. TM2MD (x'3F5C') bp2-0     :TM2CK2-0 = 001	(5) Select the prescaler output for clock source by TM2CK2-0 flag of the TM2MD register.
(6) Select the prescaler output and enable counting. CK2MD (x'3F5E') bp2-1     :TM2PSC1-0 = 01 bp0       :TM2BAS   = 1 PSCMD (x'3F6F') bp0       :PSCEN    = 1	(6) Select fs/4 for the prescaler output by TM2BAS flag, TM2PSC1-0 of the timer 2 prescaler selection register (CK2MD). Also, set the PSCEN flag of the prescaler control register (PSCMD) to "1" to enable the prescaler counting.

Setup Procedure	Description
(7) Set the synchronous output event generation cycle. TM2OC (x'3F5A') = x'63'	(7) Set the synchronous output generation cycle to the timer 2 compare register (TM2OC). The setting value is set to 100-1=99(x'63'), because 1 MHz is divided by 10 kHz. At that time, the timer 2 binary counter (TM2BC) is initialized to x'00'.
(8) Start the timer operation. TM2MD (x'3F5C') bp3 :TM2EN = 1	(8) Set the TM2EN flag of the TM2MD register to "1" to start timer 2.

TM2BC counts up from x'00'. If any data is written to the port D output register (PDOUT), the data of port D is output from the synchronous output pin in every time an interrupt request is generated by the match of TM2BC and the set value of the TM2OC register.



## 6-8 Serial Interface Transfer Clock Output

### 6-8-1 Operation


Serial interface transfer clock can be created by using the timer output signal.

■Serial Interface Transfer Clock Operation by 8-bit Timer (Timers 2, 3 and 4)

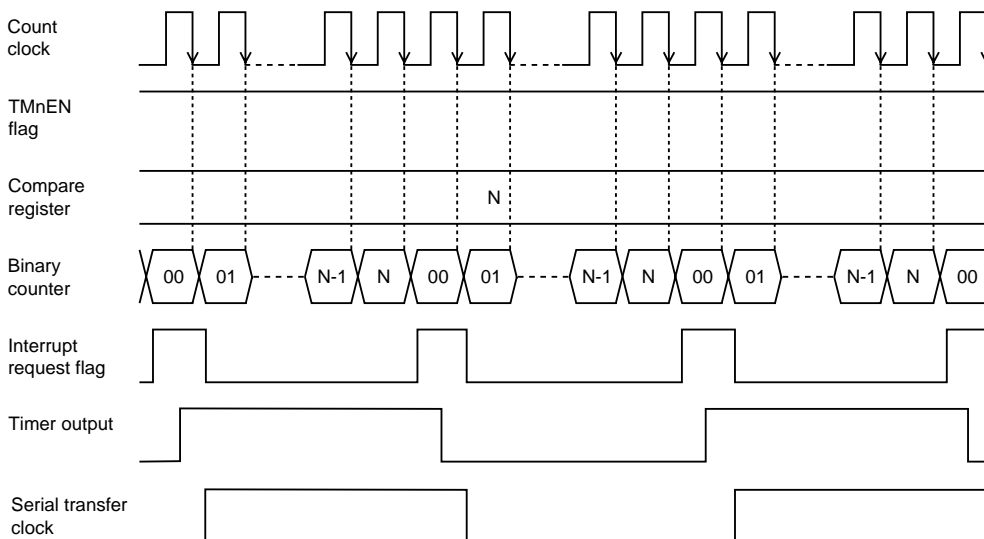
Timer 2 output can be used as a transfer clock source for serial interface 0. Timer 3 output can be used as a transfer clock source for serial interface 2, serial interface 3. Timer 4 output can be used as a transfer clock source for serial interface 0, serial interface 1.

**Table 6-8-1 Timer for Serial Interface Transfer Clock**

Serial transfer clock	Timer 2	Timer 3	Timer 4
Serial interface 0	√	-	√
Serial interface 1	-	-	√
Serial interface 2	-	√	-
Serial interface 3	-	√	-

 When timer output is selected as serial interface 0, 2 or 3 transfer clock, select fosc as a clock source of the timer. If other clock is selected, normal transfer of serial interface data is not guaranteed.

■Timing of Serial Interface Transfer Clock (Timers 2, 3 and 4)



**Figure 6-8-1 Timing of Serial Interface Transfer Clock (Timers 2, 3 and 4)**

The timer output is synchronized to the serial transfer clock by the timer count clock, and its frequency is 1/2 of the set frequency by the compare register.


Other count timings are same to the timing of timer operation. For the baud rate calculation and the serial interface setup, refer to chapter 11. Serial Interface 0 and chapter 12. Serial Interface 1.

## 6-8-2 Setup Example

### ■Serial Interface Transfer Clock Setup Example (Timer 4)

How to create a transfer clock for half duplex UART (Serial interface 1) using with timer 4 is shown below. The baud rate is selected to be 300 bps, the source clock of timer 4 is selected to be  $f_s/4$  (at  $f_{osc}=8$  MHz).

An example setup procedure, with a description of each step is shown below.

Setup Procedure	Description
(1) Stop the counter. TM4MD (x'3F64') bp3 :TM4EN = 0	(1) Set the TM4EN flag of the timer 4 mode register (TM4MD) to "0" to stop timer 4 counting.
(2) Select the normal timer operation. TM4MD (x'3F64') bp4 :TM4PWM = 0 bp5 :TM4MOD = 0	(2) Set the TM4PWM flag and TM4MOD flag of the TM4MD register to "0" to select the normal timer operation.
(3) Select the count clock source. TM4MD (x'3F64') bp2-0 :TM4CK2-0 = 001	(3) Select the clock source to prescaler output by the TM4CK2-0 flag of the TM4MD register.
(4) Select the prescaler output and enable counting. CK4MD (x'3F66') bp2-1 :TM4PSC1-0 = 01 bp0 :TM4BAS = 1 PSCMD (x'3F6F') bp0 :PSCEN = 1	(4) Select the prescaler output to $f_s/4$ by the TM4PSC1-0, TM4BAS flag of the timer 4 prescaler selection register (CK4MD). Also, set the PSCEN flag of the prescaler control register (PSCMD) to "1" to enable the prescaler counting.
(5) Set the baud rate. TM4OC (x'3F62') = x'CF'	(5) Set the timer 4 compare register (TM4OC) to the value that baud rate comes to 300 bps. [  Chapter 12. Table 12-3-19 ] At that time, the timer 4 binary counter (TM4BC) is initialized to x'00'.
(6) Start the timer operation TM4MD (x'3F64') bp3 :TM4EN = 1	(6) Set the TM4EN flag of the TM4MD register to "1" to start timer 4.

TM4BC counts up from x'00'. Timer 4 output is the clock of the serial interface 1 at transmission and reception.

For the compare register setup value and the serial operation setup, refer to chapter 12. Serial Interface 1.

## 6-9 Simple Pulse Width Measurement

### 6-9-1 Operation

Timer measures the "L" duration of the pulse signal input from the external interrupt pin.

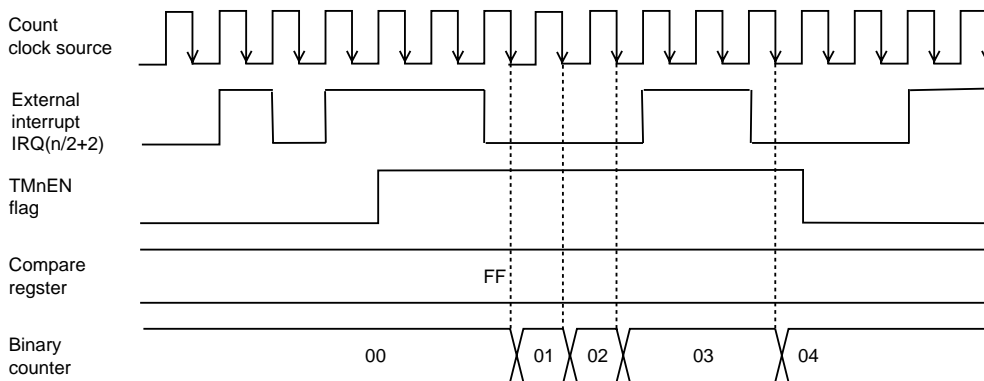
■ Simple Pulse Width Measurement Operation by 8-bit Timer (Timers 0, 2 and 4)

During the input signal of the external interrupt pin (simple pulse width) is "L", the binary counter of the timer counts up. Pulse width "L" period can be measured by reading the count of timer. 8-bit timers that have the simple pulse width measurement function are timers 0, 2 and 4.

**Table 6-9-1 Simple Pulse Width Measurement Able Pins (Timers 0, 2 and 4)**

	Timer 0	Timer 2	Timer 4
Simple pulse width measurement enable pin	External interrupt 2 (P22/IRQ2)	External interrupt 3 (P23/IRQ3)	External interrupt 4 (P24/IRQ4)

■ Count Timing of Simple Pulse Width Measurement (Timer 0, Timer 2, Timer 4)



**Figure 6-9-1 Count Timing at Measurement of Simple Pulse Width (Timer 0, Timer 2, Timer 4)**


During the input signal of the external interrupt pin for simple pulse width measurement is "L" at TMnEN flag operation ("1"), timer counts up.

## 6-9-2 Setup Example

### ■Set up Example of Simple Pulse Width Measurement by 8-bit Timer (Timers 0, 2 and 4)

The pulse width of 'L' period of the external interrupt 2 (IRQ2) input signal is measured by timer 0. The clock source of timer 0 is selected to fosc.

An example setup procedure, with a description of each step is shown below.

Setup Procedure	Description
(1) Stop the counter. TM0MD (x'3F54') bp3      :TM0EN      = 0	(1) Set the TM0EN flag of the timer 0 mode register (TM0MD) to stop timer 0 counting.
(2) Set the pulse width measurement operation. TM0MD (x'3F54') bp4      :TM0PWM     = 0 bp5      :TM0MOD     = 1	(2) Set the TM0PWM flag of the TM0MD register to "0" and TM0MOD flag to "1" to enable the timer operation during "L" period to be measured.
(3) Select the count clock source. TM0MD (x'3F54') bp2-0    : TM0CK2-0 = 000	(3) Set the clock source to fosc by the TM0CK2-0 flag of the TM0MD register.
(4) Set the compare register. TM0OC (X'3F52')      = x'FF'	(4) Set the timer 0 compare register (TM0OC) to the bigger value than ("L"period of measured pulse width / the cycle of fosc). At that time, the timer 0 binary counter (TM0BC) is initialized to x'00'.
(5) Set the interrupt level IRQ2ICR (x'3FE4') bp7-6    :IRQ2LV1-0 = 10	(5) Set the interrupt level by the IRQ2LV1-0 flag of the external interrupt 2 control register (IRQ2ICR). If interrupt request flag is already set, clear all interrupt request flags. [  Chapter 3. 3-1-4 Interrupt Flag Setup ]
(6) Set the interrupt valid edge. IRQ2ICR (x'3FE4') bp5      :REDG2      = 1	(6) Set the REDG2 flag of the IRQ2ICR register to "1" to specify the interrupt valid edge to the rising edge.

Setup Procedure	Description
(7) Enable the interrupt. IRQ2ICR (x'3FE4') bp1      :IRQ2IE      = 1	(7) Set the IRQ2IE flag of the IRQ2ICR register to "1" to enable the interrupt.
(8) Enable the timer operation. TM0MD (x'3F54') bp3      :TM0EN      = 1	(8) Set the TM0EN flag of the TM0MD register to "1" to enable timer 0 operation.

TM0BC starts to count up with negative edge of the external interrupt 2 (IRQ2) input as a trigger. Timer 0 continues to count up during "L" period of IRQ2 input, then stop the counting with positive edge of IRQ2 input as a trigger. At the same time, reading the value of TM0BC by interrupt handling can detect "L" period.

## 6-10 Cascade Connection


### 6-10-1 Operation

Cascading timers 0 and 1, or timer 2 and 3 form a 16-bit timer.

#### ■8-bit Timer Cascade Connection Operation (Timer 0 + Timer 1, Timer 2 + Timer 3)

Timer 0 and timer 1, or timer 2 and timer 3 are combined to be a 16-bit timer. Cascading timer is operated at clock source of timer 0 or timer 2 which are lower 8 bits.

**Table 6-10-1 Timer Functions at Cascade Connection**

	Timer 0 + Timer 1 (16 Bit)	Timer 2 + Timer 3 (16 Bit)
Interrupt source	TM1IRQ	TM3IRQ
Timer operation	√	√
Event count	√ (TM0IO input)	√ (TM2IO input)
Timer pulse output	√ (TM1IO output)	√ (TM3IO output)
PWM output	-	-
Synchronous output	√	-
Serial Interface transfer clock output	-	√ (TM3IO output)
Pulse width measurement	√	√
Remote control carrier output	-	√
Clock source	fosc fosc/4 fosc/16 fosc/32 fosc/64 fs/2 fs/4 fx TM0IO input	fosc fosc/4 fosc/16 fosc/32 fosc/64 fs/2 fs/4 fx TM2IO input
fosc : Machine clock (High speed oscillation ) fx : Machine clock (Low speed oscillation ) fs : System clock [  Chapter 2 2-5 Clock Switching ]		

At cascade connection, the binary counter and the compare register are operated as a 16 bit register. At operation, set the TMnEN flag of the upper and lower 8-bit timers to "1" to be operated. Also, the clock source is the one which is selected in the lower 8-bit timer. Other setup and count timing is the same to the 8-bit timer at independently operation.



When timer 0 and timer 1 are used in cascade connection, timer 1 interrupt request flag is used. Timer pulse output of timer 0 is "L" fixed output. An interrupt request of timer 0 is not generated, and the timer 0 interrupt should be disabled.



When timer 2 and timer 3 are used in cascade connection, timer 3 interrupt request flag is used. Timer pulse output of timer 2 is "L" fixed output. An interrupt request of timer 2 is not generated, and the timer 2 interrupt should be disabled.



At the cascade connection, if the binary counter should be cleared by rewriting the compare register, the TMnEN flags of the lower and upper 8 bits timers mode registers should be set to "0" to stop the counting, then rewrite the compare register.




## 6-10-2 Setup Example

### ■ Cascade Connection Timer Setup Example (Timer 0 + Timer 1, Timer 2 + Timer 3)


Setting example of timer function that an interrupt is constantly generated by cascade connection of timer 0 and timer 1, as a 16-bit timer is shown. An interrupt is generated in every 2500 cycles (1 ms) by selecting source clock to  $f_s/4$  ( $f_{osc}=20$  MHz at operation).


An example setup procedure, with a description of each step is shown below.

Setup Procedure	Description
(1) Stop the counter. TM0MD (x'3F54') bp3 :TM0EN = 0 TM1MD (x'3F55') bp3 :TM1EN = 0	(1) Set the TM0EN flag of the timer 0 mode register (TM0MD) to "0", the TM1EN flag of the timer 1 mode register to "0" to stop timer 0 and timer 1 counting.
(2) Select the normal operation lower timer. TM0MD (x'3F54') bp4 :TM0PWM = 0 bp5 :TM0MOD = 0	(2) Set both of the TM0PWM flag and TM0MOD flag of the TM0MD register to "0" to select the normal operation of timer 0.
(3) Set the cascade connection. TM1MD (x'3F55') bp4 :TM1CAS = 1	(3) Set the TM1CAS flag of the TM1MD register to "1" to connect timer 1 and timer 0 in cascade connection.
(4) Select the count clock source. TM0MD (x'3F54') bp2-0 :TM0CK2-0 = 001	(4) Set the clock source to prescaler output by the TM0CK2-0 flag of the TM0MD register.
(5) Select the prescaler output and enable counting. CK0MD (x'3F56') bp2-1 :TM0PSC1-0= 01 bp0 :TM0BAS = 1 PSCMD (x'3F6F') bp0 :PSCEN = 1	(5) Set the prescaler output to $f_s/4$ by the TM0PSC1-0, TM0BAS flag of the timer 0 prescaler selection register (CK0MD). Also, set the PSCEN flag of the prescaler control register (PSCMD) to "1" to enable the prescaler counting.
(6) Set the interrupt generation cycle TMnOC(x'3F53', x'3F52')=x'09C3'	(6) Set the timer 1 compare register + timer 0 compare register (TM1OC + TM0OC) to the interrupt generation cycle (x'09C3' : 2500 cycles - 1). At that time, timer 1 binary counter + timer 0 binary counter (TM1BC + TM0BC) are initialized to x'0000'.

Setup Procedure	Description
(7) Disable the lower timer interrupt. TM0ICR (x'3FE9') bp1 :TM0IE = 0	(7) Set the TM0IE flag of the timer 0 interrupt control register (TM0ICR) to "0" to disable the interrupt.
(8) Set the level of the upper timer interrupt. TM1ICR (x'3FEA') bp7-6 :TM1LV1-0 = 10	(8) Set the interrupt level by the TM1LV1-0 flag of the timer 1 interrupt control register (TM1ICR). If any interrupt request flag may be already set, clear all request flags. [  Chapter 3 3-1-4. Interrupt Flag Setup ]
(9) Enable the upper timer interrupt. TM1ICR (x'3FEA') bp1 :TM1IE = 1	(9) Set the TM1IE flag of the TM1ICR register to "1" to enable the interrupt.
(10) Start the upper timer operation. TM1MD (x'3F55') bp3 :TM1EN = 1	(10) Set the TM1EN flag of the TM1MD register to "1" to start timer 1.
(11) Start the lower timer operation. TM0MD (x'3F54') bp3 :TM0EN = 1	(11) Set the TM0EN flag of the TM0MD register to "1" to start timer 0.

TM1BC + TM0BC counts up from x'0000' as a 16-bit timer. When TM1BC + TM0BC reaches the set value of TM1OC + TM0OC register, the timer 1 interrupt request flag is set to "1" at the next count clock, and the value of TM1BC + TM0BC becomes x'0000' and counting up is restarted.

 Use a 16-bit access instruction to set the (TM1OC + TM0OC) register.

 Start the upper timer operation before the lower timer operation.

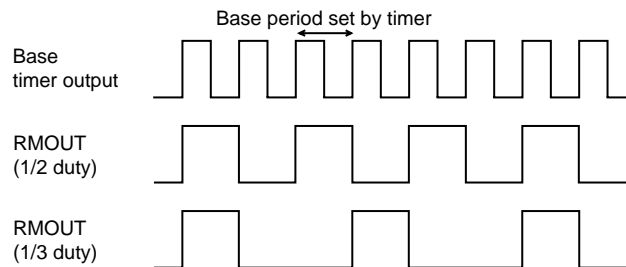
## 6-11 Remote Control Carrier Output

### 6-11-1 Operation

Carrier pulse for remote control can be generated.

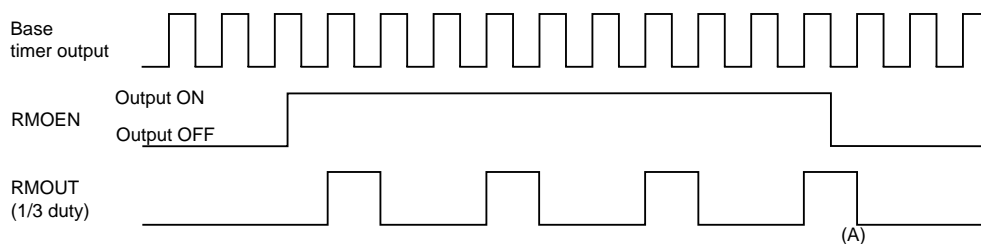
#### ■ Operation of Remote Control Carrier Output (Timer 0, Timer 3)

Remote control carrier pulse is based on output signal of timer 0 or timer 3. Duty cycle is selected from 1/2, 1/3. RMOUT (P10) outputs remote control carrier output signal.



**Figure 6-11-1 Duty Cycle of Remote Control Carrier Output Signal**

#### ■ Count Timing of Remote Control Carrier Output (Timer 0, Timer 3)



**Figure 6-11-2 Count Timing of Remote Control Carrier Output Function (Timer 0, Timer 3)**

(A) Even if the RMOEN flag is off when the carrier output is high, the carrier waveform is held by the synchronizing circuit.



Before the RMOEN flag is switched to on, set the P10MD0 flag of the P10MD register to "1". After it is switched to off, set it to "0".



When the RMOEN flag is changed, do not change the base cycle and its duty at the same time. If they are changed at the same time, the carrier wave form is not output properly.

## 6-11-2 Setup Example

### ■ Remote Control Carrier Output Setup Example (Timer 0, Timer 3)

Here is the setting example that the RMOUT pin outputs the 1/3 duty carrier pulse signal with "H" period of 36.7 kHz, by using timer 0. The source clock of timer 0 is set to fosc (at 8 MHz).

An example setup procedure, with a description of each step is shown below.

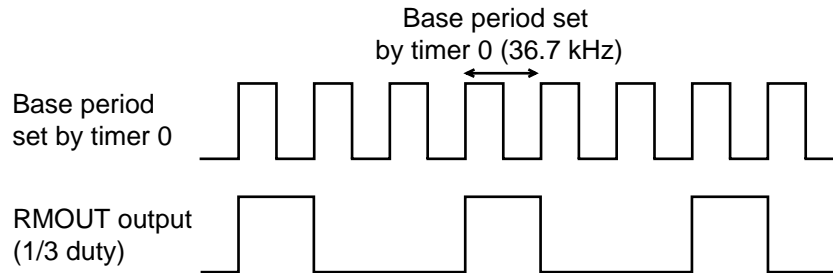


Figure 6-11-3 Output Wave Form of RMOUT Output Pin

Setup Procedure	Description
(1) Disable the remote control carrier output. RMCTR (x'3F6E') bp3 : RMOEN = 0	(1) Set the RMOEN flag of the remote control carrier output control register (RMCTR) to "0" to disable the remote control carrier output.
(2) Select the base cycle setting timer. RMCTR (x'3F6E') bp0 : RMBTMS = 0	(2) Set the RMBTMS flag of the RMCTR register to "0" to set the timer as a base cycle setting timer.
(3) Select the carrier output duty. RMCTR (x'3F6E') bp1 : RMDTY0 = 1	(3) Set the RMDTY0 flag of the RMCTR register to "1" to select 1/3 duty.
(4) Stop the counter. TM0MD (x'3F54') bp3 : TM0EN = 0	(4) Set the TM0EN flag of the timer 0 mode register (TM0MD) to stop the timer 0 counting.
(5) Set the remote control carrier output of the special function pin. P1OMD (x'3F2F') bp0 : P1OMD0 = 1 P1DIR (x'3F31') bp0 : P1DIR0 = 1 RMCTR (x'3F6E') bp4 : TM0RM = 1	(5) Set the P1OMD0 flag of the port 1 output mode register (P1OMD) to "1" to set P10 pin as a special function pin. Set the P1DIR0 flag of the port 1 direction control register (P1DIR) to "1" for output mode. Set the TM0RM flag of the RMCTR register to "1" to select the remote control carrier output.

Setup Procedure	Description
(6) Select the normal timer operation. TM0MD (x'3F54') bp4 : TM0PWM = 0 bp5 : TM0MOD = 0	(6) Set both of the TM0MOD flag and TM0PWM flag of the TM0MD register to "0" to select normal timer operation.
(7) Select the count clock source. TM0MD (x'3F54') bp2-0 : TM0CK2-0 = 000	(7) Select fosc to clock source by the TM0CK2-0 flag of the TM0MD register.
(8) Set the base cycle of remote control carrier. TM0OC (x'3F52') = x'6C'	(8) Set the base cycle of remote control carrier by writing x'6C' to the timer 0 compare register (TM0OC). The set value should be $(8 \text{ MHz} / 73.4 \text{ kHz}) - 1 = 108(x'6C')$ 8 MHz is divided to be 73.4 kHz, 2 times 36.7 kHz.
(9) Start the timer operation. TM0MD (x'3F54') bp3 : TM0EN = 1	(9) Set the TM0EN flag of the TM0MD register to "1" to stop the timer 0 counting.
(10) Enable the remote control carrier output. RMCTR (x'3F6E') bp3 : RMOEN = 1	(10) Set the RMOEN flag of the RMCTR register to "1" to enable the remote control carrier output.

TM0BC counts up from x'00'. Timer 0 outputs the base cycle pulse set in TM0OC. Then, the 1/3 duty remote control carrier pulse signal is output. If the RMOEN flag of the RMCTR register is set to "0", the remote control carrier pulse signal output is stopped.



## Chapter 7 16-bit Timer


## 7-1 Overview

This LSI contains a general-purpose 16-bit timer (Timer 7). Its compare register is double buffer type. Timer 7 (high function 16-bit timer) has 2 sets of compare registers with double buffering. Also, as an independent interrupt it has a timer 7 interrupt and a timer 7 compare register 2 match interrupt.

### 7-1-1 Functions

Table 7-1-1 shows the functions of timer 7.

**Table 7-1-1 16-bit Timer Functions**

	Timer 7 (High precision 16-bit timer)
Interrupt source	TM7IRQ T7OC2IRQ
Timer operation	√
Event count	√
Timer pulse output	√
PWM output (duty is changeable)	√
High precision PWM output (duty and cycle are changeable)	√
Synchronous output	√
Capture function	√
Pulse width measurement	√
Clock source	fosc fosc/2 fosc/4 fosc/16 fs fs/2 fs/4 fs/16 TM7IO input TM7IO input/2 TM7IO input/4 TM7IO input/16
fosc : Machine clock (High speed oscillation ) fs : System clock [  Chapter 2 2-5 Clock Switching ]	



## 7-1-2 Block Diagram

### ■Timer 7 Block Diagram

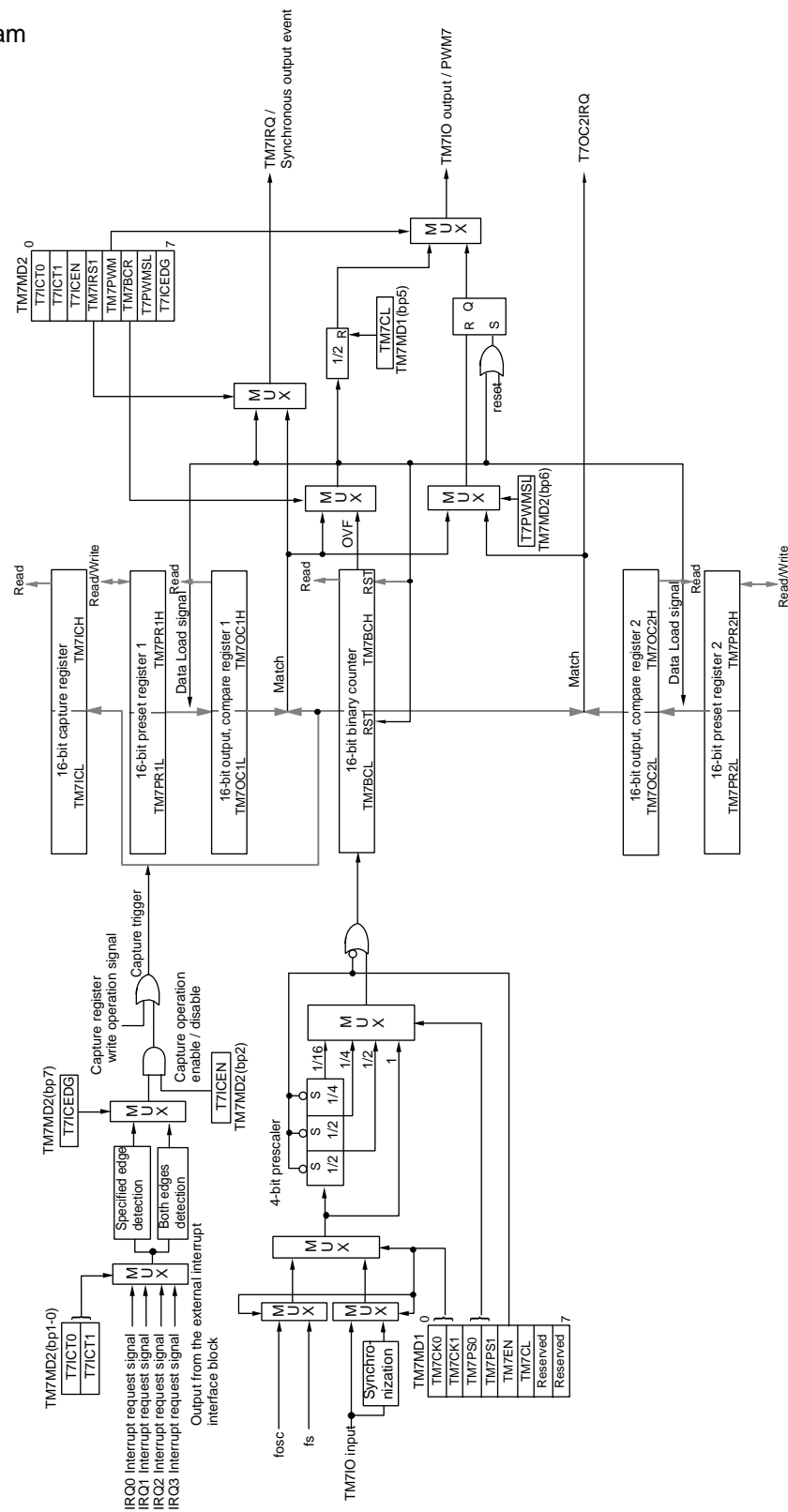


Figure 7-1-1 Timer 7 Block Diagram

## 7-2 Control Registers

Timer 7 contains the binary counter (TM7BC), the compare register 1 (TM7OC1), and its double buffer preset register (TM7PR1), the compare register 2 (TM7OC2) and its double buffer preset register 2 (TM7PR2), the capture register (TM7IC). The mode register 1 (TM7MD1) and the mode register 2 (TM7MD2) controls timer 7.

### 7-2-1 Registers

Table 7-2-1 shows the registers that control timer 7.

**Table 7-2-1 16-bit Timer Control Registers**

	Register	Address	R/W	Function	Page
Timer 7	TM7BCL	x'03F70'	R	Timer 7 binary counter (lower 8 bits)	VII - 7
	TM7BCH	x'03F71'	R	Timer 7 binary counter (upper 8 bits)	VII - 7
	TM7OC1L	x'03F72'	R	Timer 7 compare register 1 (lower 8 bits)	VII - 5
	TM7OC1H	x'03F73'	R	Timer 7 compare register 1 (upper 8 bits)	VII - 5
	TM7PR1L	x'03F74'	R/W	Timer 7 preset register 1 (lower 8 bits)	VII - 6
	TM7PR1H	x'03F75'	R/W	Timer 7 preset register 1 (upper 8 bits)	VII - 6
	TM7ICL	x'03F76'	R	Timer 7 capture register (lower 8 bits)	VII - 7
	TM7ICH	x'03F77'	R	Timer 7 capture register (upper 8 bits)	VII - 7
	TM7MD1	x'03F78'	R/W	Timer 7 mode register 1	VII - 8
	TM7MD2	x'03F79'	R/W	Timer 7 mode register 2	VII - 9
	TM7OC2L	x'03F7A'	R	Timer 7 compare register 2 (lower 8 bits)	VII - 5
	TM7OC2H	x'03F7B'	R	Timer 7 compare register 2 (upper 8 bits)	VII - 5
	TM7PR2L	x'03F7C'	R/W	Timer 7 preset register 2 (lower 8 bits)	VII - 6
	TM7PR2H	x'03F7D'	R/W	Timer 7 preset register 2 (upper 8 bits)	VII - 6
	TM7ICR	x'03FF1'	R/W	Timer 7 interrupt control register	III - 31
	T7OC2ICR	x'03FF2'	R/W	Timer 7 compare register 2 match interrupt control register	III - 32
	P1OMD	x'03F2F'	R/W	Port 1 output mode register	IV - 15
P1DIR	x'03F31'	R/W	Port 1 direction control register	IV - 14	

R/W : Readable/Writable

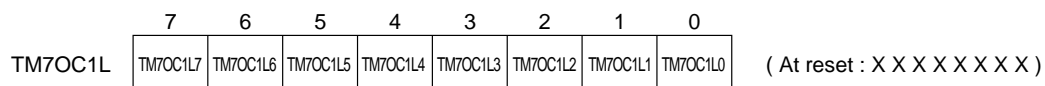
R : Readable only

## 7-2-2 Programmable Timer Registers

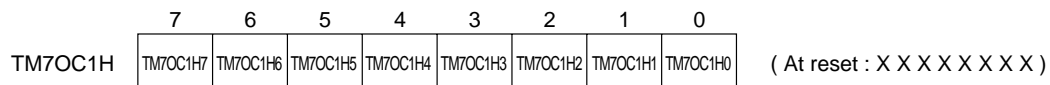
Timer 7 has a 16-bit programmable timer register. It contains a compare register, a preset register, a binary counter and a capture register. Each register has 2 sets of 8-bit register. Operate by 16-bit access.

Compare register is a 16-bit register stores the value that compared to binary counter. The compared value that written to the preset register in advance is loaded.

### ■Timer 7 Compare Register 1 (TM7OC1)

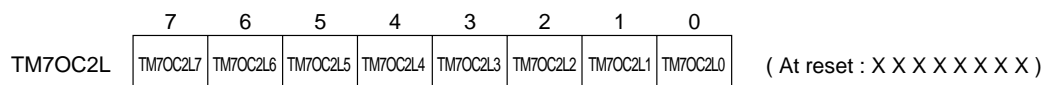


**Figure 7-2-1 Timer 7 Compare Register 1 Lower 8 bits (TM7OC1L : x'03F72', R)**

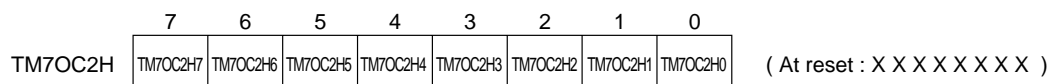


**Figure 7-2-2 Timer 7 Compare Register 1 Upper 8 bits (TM7OC1H : x'03F73', R)**

### ■Timer 7 Compare Register 2 (TM7OC2)



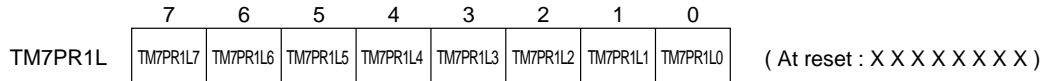
**Figure 7-2-3 Timer 7 Compare Register 2 Lower 8 bits (TM7OC2L : x'03F7A', R)**



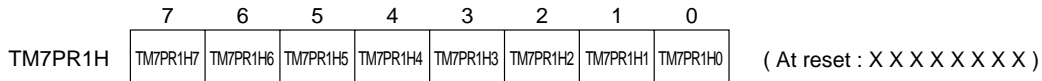
**Figure 7-2-4 Timer 7 Compare Register 2 Upper 8 bits (TM7OC2H : x'03F7B', R)**

The timer 7 preset register 1 and 2 are buffer registers of the timer 7 compare register 1 and 2. If the set value is written to the timer 7 preset register 1 and 2 when the counting is stopped, the same set value is loaded to the timer 7 compare register 1 and 2. If the set value is written to the timer 7 preset register 1 and 2 when the counting is operated, the set value of the timer 7 preset register 1 and 2 is loaded to the timer 7 compare register 1 and 2 at the timing that the timer 7 binary counter is cleared.

■Timer 7 Preset Register 1 (TM7PR1)

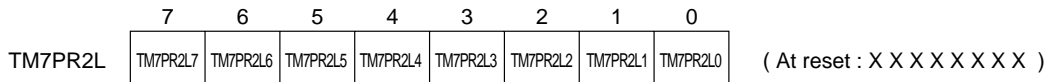


**Figure 7-2-5 Timer 7 Preset Register 1 Lower 8 bits (TM7PR1L : x'03F74', R/W)**

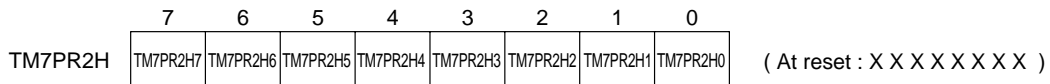


**Figure 7-2-6 Timer 7 Preset Register 1 Upper 8 bits (TM7PR1H : x'03F75', R/W)**

■Timer 7 Preset Register 2 (TM7PR2)



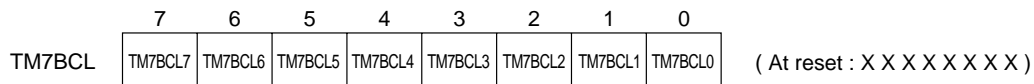
**Figure 7-2-7 Timer 7 Preset Register 2 Lower 8 bits (TM7PR2L : x'03F7C', R/W)**



**Figure 7-2-8 Timer 7 Preset Register 2 Upper 8 bits (TM7PR2H : x'03F7D', R/W)**

Binary counter is a 16-bit up counter. If any data is written to a preset register when the counting is stopped, the binary counter is cleared to x'0000'.

#### ■Timer 7 Binary Counter (TM7BC)



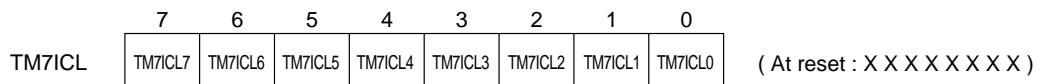
**Figure 7-2-9 Timer 7 Binary Counter Lower 8 bits (TM7BCL : x'03F70', R)**



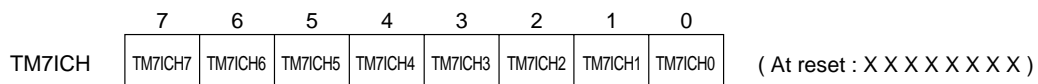
**Figure 7-2-10 Timer 7 Binary Counter Upper 8 bits (TM7BCH : x'03F71', R)**

Input capture register is a register that holds the value loaded from a binary counter by capture trigger. Capture trigger is generated by an input signal from an external interrupt pin, and when an arbitrary value is written to an input capture register (Directly writing to the register by program is disable.).

#### ■Timer 7 Input Capture Register (TM7IC)



**Figure 7-2-11 Timer 7 Input Capture Register Lower 8 bits (TM7ICL : x'03F76', R)**



**Figure 7-2-12 Timer 7 Input Capture Register Upper 8 bits (TM7ICH : x'03F77', R)**

### 7-2-3 Timer Mode Registers

This is a readable / writable register that controls timer 7.

■Timer 7 Mode Register 1 (TM7MD1)

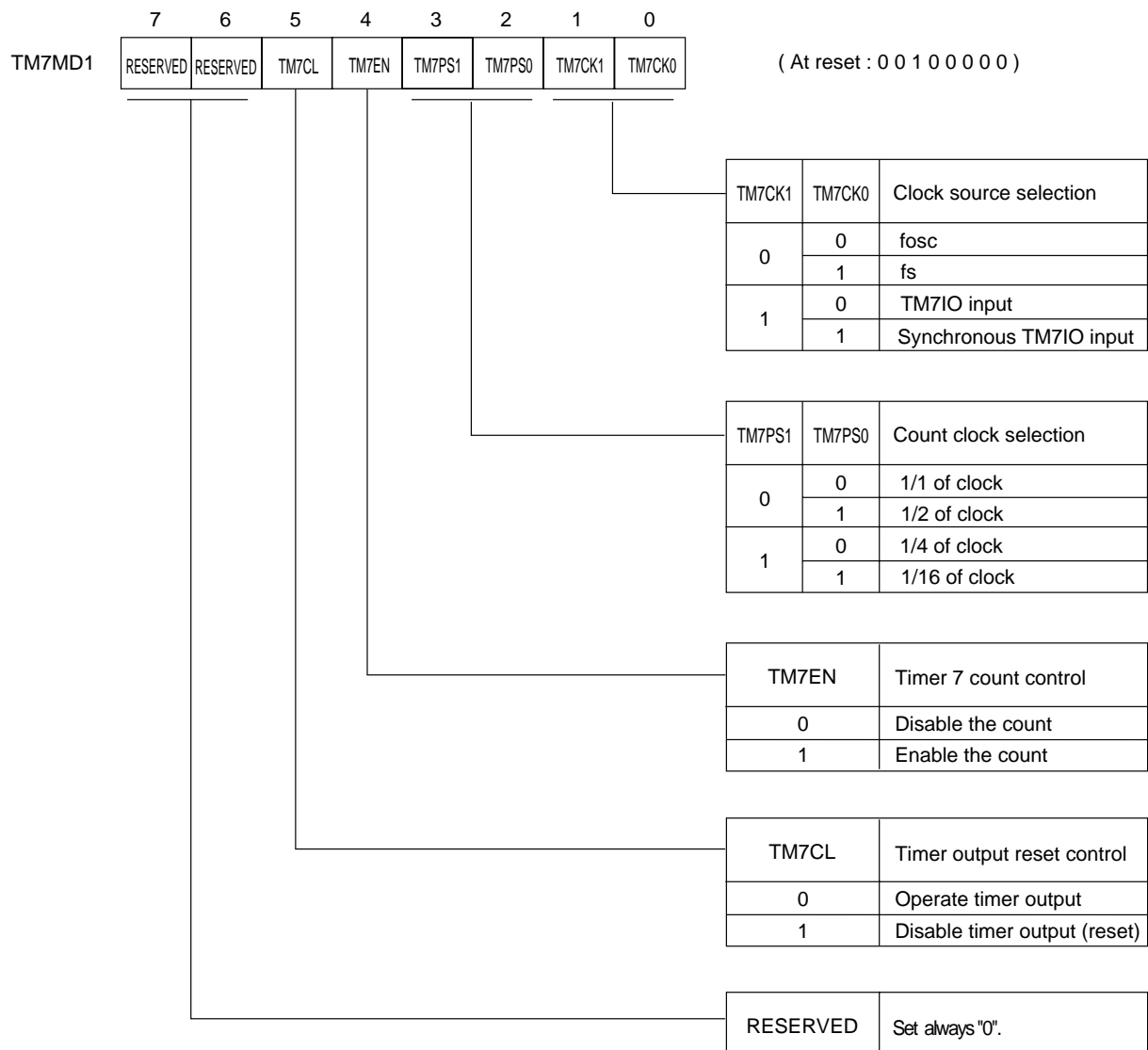


Figure 7-2-13 Timer 7 Mode Register 1 (TM7MD1 : x'03F78', R/W)

■Timer 7 Mode Register 2 (TM7MD2)

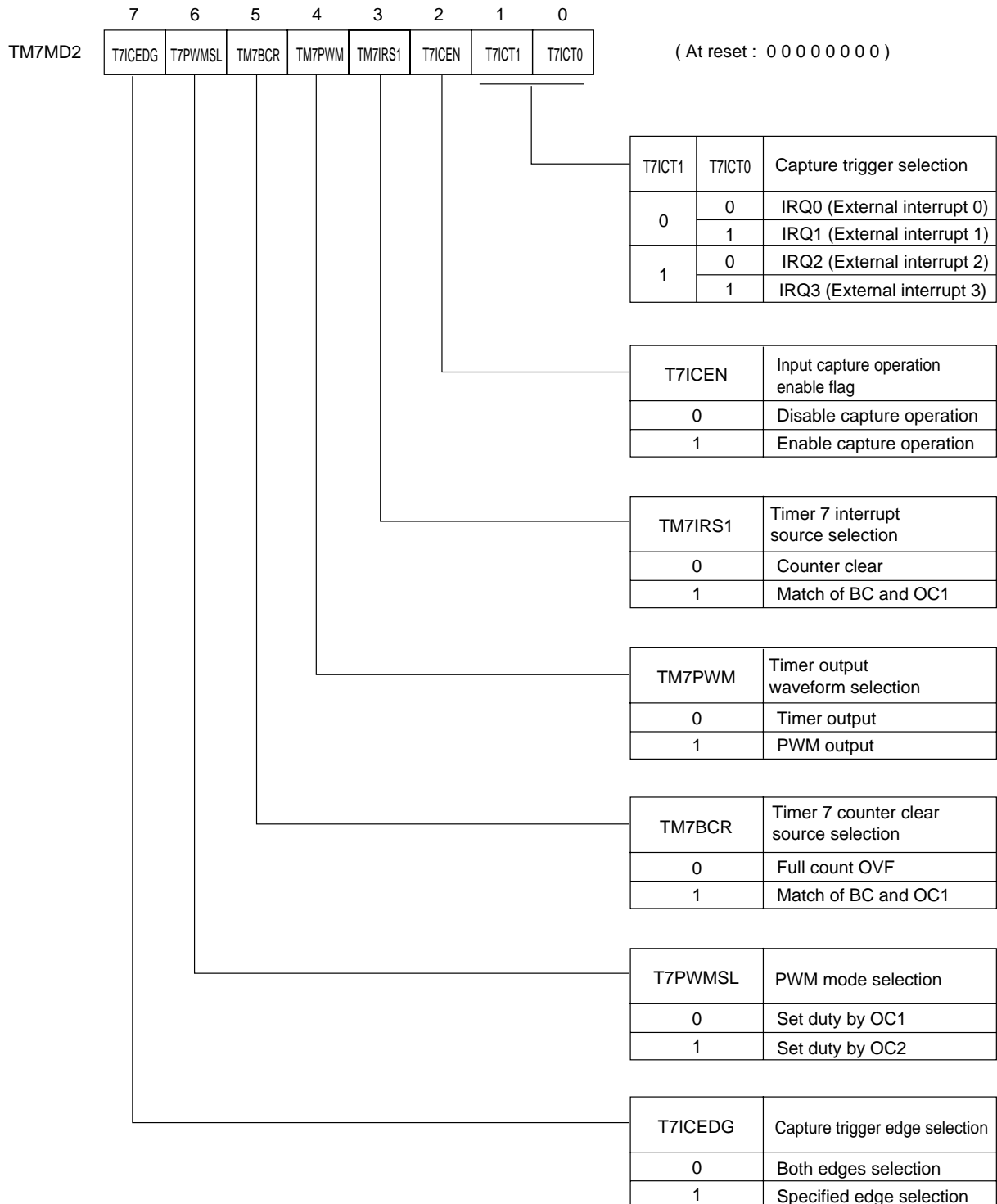


Figure 7-2-14 Timer 7 Mode Register 2 (TM7MD2 : x'03F79', R/W)

## 7-3 16-bit Timer Count

### 7-3-1 Operation

The timer operation can constantly generate interrupts.

#### ■16-bit Timer Operation (Timer 7)

The generation cycle of an timer interrupt is set by the clock source selection and the set value of the compare register 1 (TM7OC1), in advance. When the binary counter (TM7BC) reaches the set value of the compare register 1, the timer 7 interrupt request is generated at the next count clock. There are 2 sources ; the TM7OC1 compare match or the full count over flow, to be selected to clear the binary counter. After the binary counter is cleared to x'0000, the counting up is restarted from x'0000'.

**Table 7-3-1 16-bit Timer Interrupt Source and Binary Counter Clear Source (Timer 7)**

TM7MD2 register		Interrupt source	Binary counter clear source
TM7IRS1 flag	TM7BCR flag		
1	1	TM7OC1 compare match	TM7OC1 compare match
0	1	TM7OC1 compare match	TM7OC1 compare match
1	0	TM7OC1 compare match	full count over flow
0	0	full count over flow	full count over flow


Timer 7 can generate another set of an independent interrupt (Timer 7 compare register 2 match interrupt) by the set value of the timer 7 compare register (TM7OC2). At that timer, the binary counter is cleared as the above setup.

The compare register is double buffer type. So, when the value of the preset register is changed during the counting, the changed value is stored to the compare register as the binary counter is cleared. This function can change its value of the compare register constantly, without disturbing the cycle during timer operation (Reload function).



When the CPU reads the 16-bit binary counter (TM7BC), the read data is treated as 8-bits unit data even if it is a 16-bit MOVW instruction. As a result, it will read the data incorrectly if a carry from the lower 8 bits to the upper 8 bits occurs during counting.

To read the correct value of the 16-bit counting (TM7BC), use the writing program function to the input capture register (TM7IC). By writing to the TM7IC, the counting data of TM7BC can be stored to TM7IC to read out the correct counting data during operation.

[  Chapter 7-9-1. Operation (p.VII-36) ]



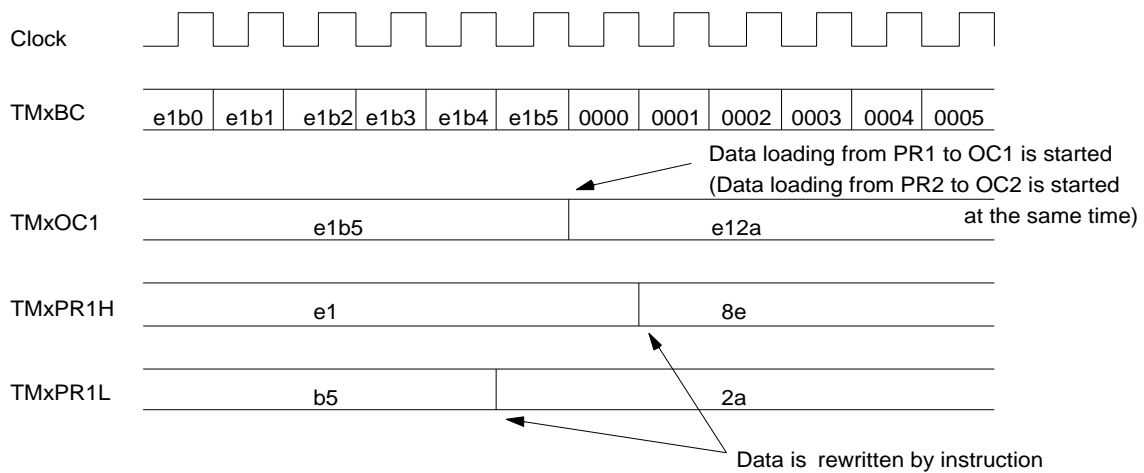


When a data is written to 16-bit timer preset register (TM7PR1, TM7PR2), it is recognized as a 8-bit unit data inside LSI even if it is a 16-bit access MOVW instruction. After lower 8 bits of preset register is written, if data loading from preset register to compare register is started before the upper 8 bits is written, data which is not rewritten is loaded to the upper 8 bits and rewritten data is loaded to the lower 8 bits.

Therefore, writing data to the preset register (TM7PR1, TM7PR2) need to be completed before data loading from the preset register to the compare register is started.

Shown below is timing chart of TM7PR1 and TM7OC1 data rewriting and the data loading. When data is written to TM7PR2 wrong data could be loaded due to the same problem.

TM7BC and TM7OC1 compare match and load timing of TM7PR1



Data e12a is loaded to OC1 as PR1rewriting (e1b5 -> 8e2a) and loading to OC1 are operated at the same time.

Table 7-3-2 shows the clock source that can be selected.

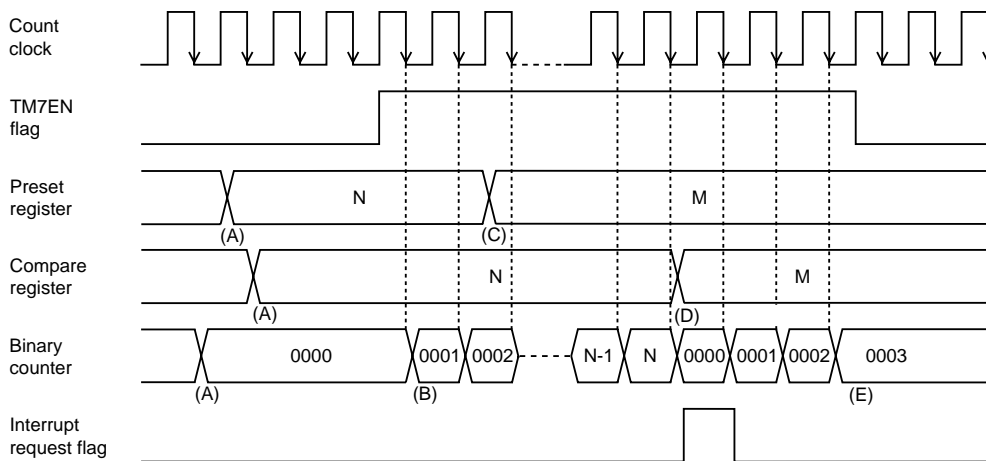
**Table 7-3-2 Clock Source at Timer Operation(Timer 7)**

Clock source	1 count time
fosc	50 ns
fosc/2	100 ns
fosc/4	200 ns
fosc/16	800 ns
fs	100 ns
fs/2	200 ns
fs/4	400 ns
fs/16	1.6 μs
as fosc = 20 MHz, fs = fosc/2 = 10 MHz	

■Count Timing of Timer Operation (Timer 7)

The binary counter counts up with the selected clock source as the count clock.

The basic operation of the whole function of 16-bit timer is as follows ;



**Figure 7-3-1 Count Timing of Timer Operation (Timer 7)**

- (A) When any data is written to the preset register as the TM7EN flag is stopped ("0"), the same value is loaded at the writing cycle and the binary counter is cleared to x'0000'.
- (B) If the TM7EN flag is "1", the binary counter starts counting. The counting is happened at the falling edge of the count clock.

- (C) Even if the preset register is rewritten as the TM7EN flag is "1", the binary counter is not changed.
- (D) If the binary counter reaches the value of the compare register 1, the set value of the preset register is loaded to the compare register at the next count clock. And the interrupt request flag is set at the next count clock, and the binary counter is cleared to x'0000' to restart counting up.
- (E) If the TM7EN flag is "0", the binary counter is stopped.



When the binary counter reaches the value of the compare register, the interrupt request flag is set and the binary counter is cleared, at the next count clock. So, set the compare register as; (the set value of the compare register) = (count till the interrupt request - 1)



When the timer 7 compare register 2 match interrupt is generated and the TM7OC1 compare match is selected as a binary counter clear source, the set value of the compare register 2 should be smaller than the set value of the compare register 1.



If the interrupt is enabled, the timer interrupt request flag should be cleared before timer operation is started.



At TM7OC=x'0000', x'0001', the timer n interrupt request generation has the same waveform.



When more than 2 waits is set at access to the special register area by the IOW1, IOW0 flag of the MEMCTR register, write the same value 2 times at setup of the preset register as the timer is stopped. When 1 wait or no wait is set, there is no need to do this.


(This is for all functions of a 16-bit timer.) [ Chapter 2 2-3-2. Control Registers]

## 7-3-2 Setup Example

### ■Timer Operation Setup Example (Timer 7)

Timer 7 generates an interrupt constantly for timer function.  $f_{osc}/2$  ( $f_{osc}=20$  MHz) is selected as a clock source to generate an interrupt every 1000 cycles (100  $\mu$ s).

An example setup procedure, with a description of each step is shown below.

Setup Procedure	Description
(1) Stop the counter. TM7MD1 (x'3F78') bp4 : TM7EN = 0	(1) Set the TM7EN flag of the timer 7 mode register 1 (TM7MD1) to "0" to stop timer 7 counting.
(2) Select the timer clear source. TM7MD2 (x'3F79') bp5 : TM7BCR = 1	(2) Set the TM7BCR flag of the timer 7 mode register 2 (TM7MD2) to "1" to select the compare match as a binary counter clear source.
(3) Select the count clock source. TM7MD1 (x'3F78') bp1-0 : TM7CK1-0 = 00 bp3-2 : TM7PS1-0 = 01	(3) Select fosc as a clock source by the TM7CK1-0 flag of the TM7MD1 register. Also select 1/2 fosc as a count clock source by TM7PS1-0 flag.
(4) Set the interrupt generation cycle. TM7PR1 (x'3F75', x'3F74')=x'03E7	(4) Set the interrupt generation cycle to the timer 7 preset register 1 (TM7PR1). The cycle is 1000. The set value should be $1000-1=999(x'03E7)$ . At that time, the same value is loaded to the timer 7 compare register 1 (TM7OC1), and the timer 7 binary counter (TM7BC) is initialized to x'0000'.
(5) Set the interrupt level. TM7ICR (x'3FF1') bp7-6 : TM7LV1-0 = 10	(5) Set the interrupt level by the TM7LV1-0 flag of the timer 7 interrupt control register (TM7ICR). If the interrupt request flag may be already set, clear the request flag. [  Chapter 3 3-1-4. Interrupt Flag Setup ]
(6) Enable the interrupt. TM7ICR (x'3FF1') bp1 : TM7IE = 1	(6) Set the TM7IE flag of the TM7ICR register to "1" to enable the interrupt.

Setup Procedure	Description
(7) Start the timer operation. TM7MD1 (x'3F78') bp4      : TM7EN      = 1	(7) Set the TM7EN flag of the TM7MD1 register to "1" to start timer 7.

TM7BC counts up from x'0000'. When TM7BC reaches the set value of the TM7OC1 register, the timer 7 interrupt request flag is set to "1" at the next count clock and the TM7BC becomes x'0000' and counts up, again.



When the TM7EN flag of the TM7MD register is changed at the same time to other bits, the binary counter may count up by the switching operation.

## 7-4 16-bit Event Count

### 7-4-1 Operation

Event count operation has 2 types ; TM7IO input and synchronous TM7IO input can be selected as the count clock. Each type can select 1/1, 1/2, 1/4 or 1/6 as a count clock source.

#### ■16-bit Event Count Operation (Timer 7)

Event count means that the binary counter (TM7BC) counts the input signal from external to the TM7IO pin. If the value of the binary counter reaches the setting value of the compare register (TM7OC), interrupts can be generated at the next count clock.

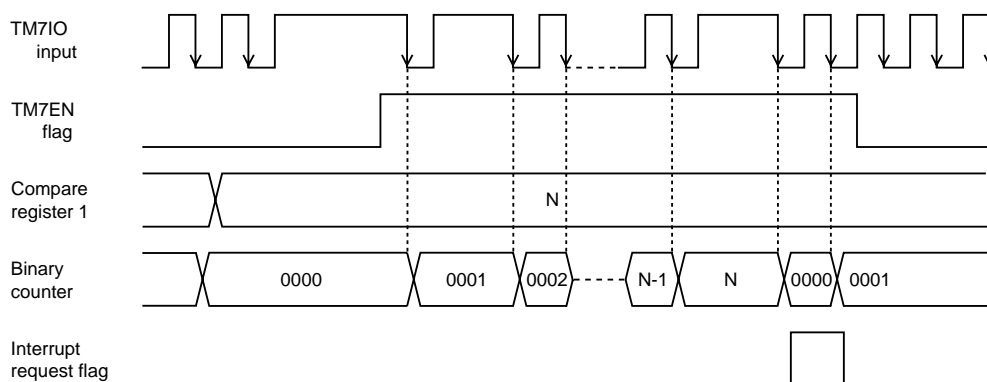
**Table 7-4-1 Event Count Input Clock**

	Timer 7
Event input	TM7IO input (P14)
	Synchronous TM7IO input

As an actual count clock, a signal divided 1, 2, 4, or 16 is selected.

#### ■Count Timing of TM7IO Input (Timer 7)

When TM7IO input is selected, TM7IO input signal is directly input to the count clock of the timer 7. The binary counter counts up at the falling edge of the TM7IO input signal or at the falling edge of the TM7IO input signal that passed the divider.



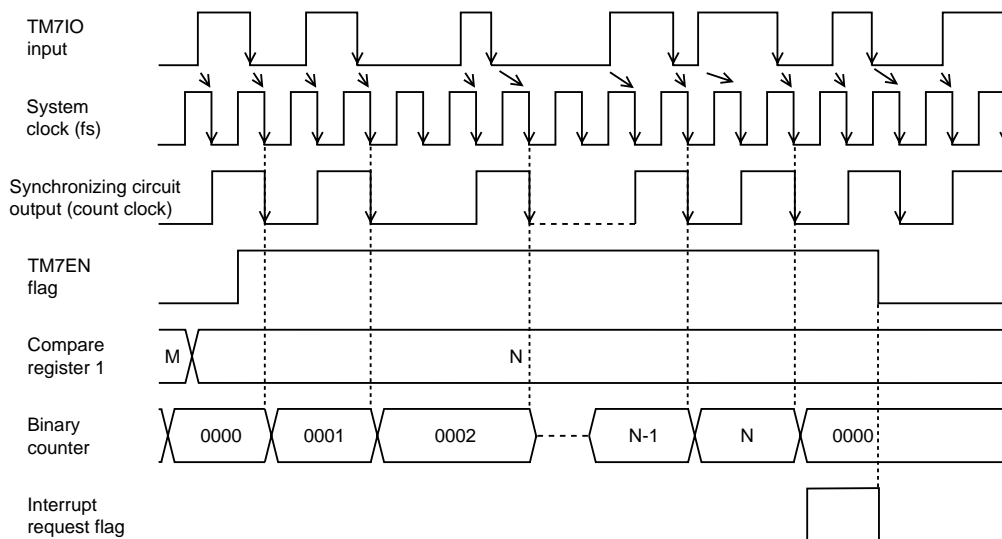
**Figure 7-4-1 Count Timing TM7IO Input (Timer 7)**



If the binary counter is read out at operation, incorrect data at counting up may be read. To prevent this, use the event count by the synchronous TM7IO input as the following page.

### ■ Count Timing of Synchronous TM7IO Input (Timer 7)

If the synchronous TM7IO input is selected, the synchronizing circuit output signal is input to the count clock. The synchronizing circuit output signal is changed at the falling edge of the system clock after the TM7IO input signal is changed. The binary counter counts up at the falling edge of the synchronizing circuit output signal or the synchronizing circuit output signal that passed through the divide-by circuit.



**Figure 7-4-2 Count Timing of Synchronous TM7IO Input (Timer 7)**




When the synchronous TM7IO input is selected as the count clock source, the timer 7 counter counts up in synchronization with the system clock. Therefore, the correct value is always read. But, if the synchronous TM7IO is selected as the count clock source, CPU mode cannot return from STOP/HALT mode.


## 7-4-2 Setup Example

### ■Event Count Setup Example (Timer 7)

If the falling edge of the TM7IO input pin signal is detected 5 times with using timer 7, an interrupt is generated. An example setup procedure, with a description of each step is shown below.

Setup Procedure	Description
(1) Stop the counter. TM7MD1 (x'3F78') bp4 : TM7EN = 0	(1) Set the TM7EN flag of the timer 7 mode register 1 (TM7MD1) to "0" to stop timer 7 counting.
(2) Set the special function pin to input mode. P1DIR (x'3F31') bp4 : P1DIR4 = 0	(2) Set the P1DIR4 flag of the port 1 direction control register (P1DIR) to "0" to set P14 pin to input mode. If it needs, pull-up resistor should be added. [  Chapter 4 I/O Ports ]
(3) Select the condition for timer clear. TM7MD2 (x'3F79') bp5 : TM7BCR = 1	(3) Set the TM7BCR flag of the timer 7 mode register 2 (TM7MD2) to "1" to select the compare match as a clear source of binary counter.
(4) Select the count clock source. TM7MD1 (x'3F78') bp1-0 : TM7CK1-0 = 10 bp3-2 : TM7PS1-0 = 00	(4) Select the TM7IO input as a clock source by the TM7CK1-0 flag of the TM7MD1 register. Also, select 1/1(no division) as a count clock source by the TM7PS1-0 flag.
(5) Set the interrupt generation cycle. TM7PR1 (x'3F75', x'3F74')=x'0004'	(5) Set the interrupt generation cycle to the timer 7 preset register 1 (TM7PR1). The set value should be 4, because the counting is 5 times. At that time, the same value is loaded to the timer 7 compare register 1 (TM7OC1), and the timer 7 binary counter (TM7BC) is initialized to x'0000'.



Setup Procedure	Description
(6) Set the interrupt level. TM7ICR (x'3FF1') bp7-6 :TM7LV1-0 = 10	(6) Set the interrupt level by the TM7LV1-0 flag of the timer 7 interrupt control register (TM7ICR). If any interrupt request flag may be already set, clear those request flags. [  Chapter 3 3-1-4. Interrupt Flag Setup ]
(7) Enable the interrupt. TM7ICR (x'3FF1') bp1 : TM7IE = 1	(7) Set the TM7IE flag of the TM7ICR register to "1" to enable interrupt.
(8) Start the event count. TM7MD1 (x'3F78') bp4 : TM7EN = 1	(8) Set the TM7EN flag of the TM7MD 1 register to "1" to start timer 7.

Every time TM7BC detects the falling edge of the TM7IO input, TM7BC counts up from x'0000'. When the TM7BC reaches the setting value of the TM7OC1 register, the timer 7 interrupt request flag is set at the next count clock, then the value of TM7BC becomes x'0000' and counting up is restarted.

## 7-5 16-bit Timer Pulse Output

### 7-5-1 Operation

TM7IO pin can output a pulse signal with an arbitrary frequency.

■16-bit Timer Pulse Output Operation (Timer 7)

The timers can output 2 x cycle signal, compared to the setting value to the compare register 1 (TM7OC1) or 1/2 the frequency of the 16-bit full count.

Output pin are as follows.

**Table 7-5-1 Timer Pulse Output Pin**

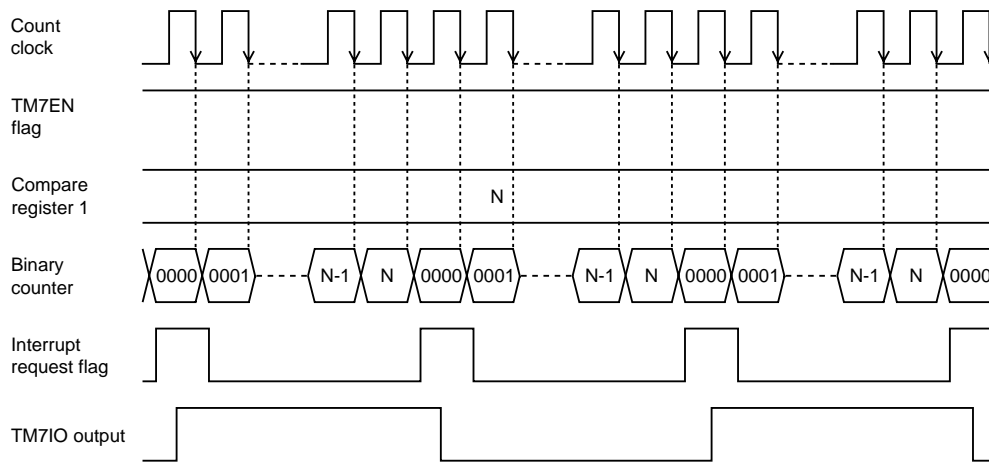
	Timer 7
Pulse output pin	TM7IO output (P14)

Table 7-5-2 shows the timer interrupt generation sources and the flags that control the timer pulse output cycle.

**Table 7-5-2 16-bit Timer Interrupt Generation Source and Timer Pulse Output Cycle (Timer 7)**

TM7MD2 register		Interrupt source	Timer pulse output cycle
TM7IRS1 flag	TM7BCR flag		
1	1	TM7OC1 compare match	set value of TM7OC1 x 2
0	1	TM7OC1 compare match	set value of TM7OC1 x 2
1	0	TM7OC1 compare match	full count of TM7BC x 2
0	0	full count over flow	full count of TM7BC x 2

### ■ Count Timing of Timer Pulse Output (Timer 7)



**Figure 7-5-1 Count Timing of Timer Pulse Output (Timer 7)**

The TM7IO pin outputs 2 x cycle, compared to the value in the compare register 1. If the binary counter reaches the compare register, and the binary counter is cleared to 'x'0000' or the full count overflow, the TM7IO output (timer output) is inverted. The inversion of the timer output is changed at the rising edge of the count clock. This is happened to form the waveform inside to correct the output cycle.




In the initial state after releasing reset, the timer pulse output is reset, and low output is fixed. Therefore, release the reset of the timer pulse output by setting the TM7CL flag of the TM7MD1 register to "0".

## 7-5-2 Setup Example

### ■Timer Pulse Output Setup Example (Timer 7)

TM7IO pin outputs 50 kHz pulse by using timer 7. For this, select fosc as clock source, and set a 1/2 cycle (100 kHz) for the timer 7 compare register (at fosc=20 MHz).

An example setup procedure, with a description of each step is shown below.

Setup Procedure	Description
(1) Stop the counter. TM7MD1 (x'3F78') bp4 : TM7EN = 0	(1) Set the TM7EN flag of the timer 7 mode register 1 (TM7MD1) to "0" to stop timer 7 counting.
(2) Set the special function pin to output mode. P1OMD (x'3F2F') bp4 : P1OMD4 = 1 P1DIR (x'3F31') bp4 : P1DIR4 = 1	(2) Set the P1OMD4 flag of the port 1 output mode register (P1OMD) to "1" to set P14 pin as the special function pin. Set the P1DIR4 flag of the port 1 direction control register (P1DIR) to "1" to set output mode. If it needs, pull-up resistor should be added. [  Chapter 4 I/O Ports ]
(3) Set the timer pulse output. TM7MD2 (x'3F79') bp4 : TM7PWM = 0	(3) Set the TM7PWM flag of the timer 7 mode register 2 (TM7MD2) to "0" to select the timer pulse output.
(4) Select the condition for timer clear. TM7MD2 (x'3F79') bp5 : TM7BCR = 1	(4) Set the TM7BCR flag of the TM7MD2 register to "1" to select the compare match as a clear source of a binary counter .
(5) Select the count clock source. TM7MD1 (x'3F78') bp1-0 : TM7CK1-0 = 00 bp3-2 : TM7PS1-0 = 00	(5) Select fosc as an clock source by the TM7CK1-0 flag of the TM7MD1 register. Also, select 1/1 frequency as an count clock source by the TM7PS1-0 flag.

Setup Procedure	Description
(6) Set the timer pulse output cycle. TM7PR1 (X'3F75', X'3F74')=x'00C7'	(6) Set the 1/2 frequency of the timer pulse output cycle to the timer 7 preset register 1 (TM7PR1). To be 100 kHz by a divided 20 MHz, set as follows ; $200 - 1 = 199$ (x'C7') At that time, the same value is loaded to the timer 7 compare register 1 (TM7OC1) and the timer 7 binary counter (TM7BC) is initialized to x'0000'.
(7) Release the reset of the timer pulse output. TM7MD1 (x'3F78') bp5 : TM7CL = 0	(7) Set the TN7CL flag of the TM7MD 1 register to "0" to enable the timer pulse output.
(8) Start the timer operation. TM7MD1 (x'3F78') bp4 : TM7EN = 1	(8) Set the TM7EN flag of the TM7MD1 register to "1" to start timer 7.

TM7BC counts up from x'0000'. If TM7BC reaches the set value of the TM7OC1 register and TM7BC is cleared to x'0000', the signal of the TM7IO output is inverted and TM7BC counts up from x'0000', again.



At TM7OC1 = x'0000' and x'0001', the timer pulse output has the same waveform.



Either binary counter stops or operates, the timer output is "L", when the TM7CL flag of the TM7MD2 register is set to "1".



Set the compare register value as follows.

The compare register value =  $\frac{\text{The timer pulse output cycle}}{\text{The count clock cycle} \times 2} - 1$

## 7-6 16-bit Standard PWM Output

(Only duty can be changed consecutively)

The TM7IO pin outputs the standard PWM output, which is determined by the over flow timing of the binary counter, and the match timing of the timer binary counter and the compare register.

### 7-6-1 Operation

#### ■16-bit Standard PWM Output (Timer 7)

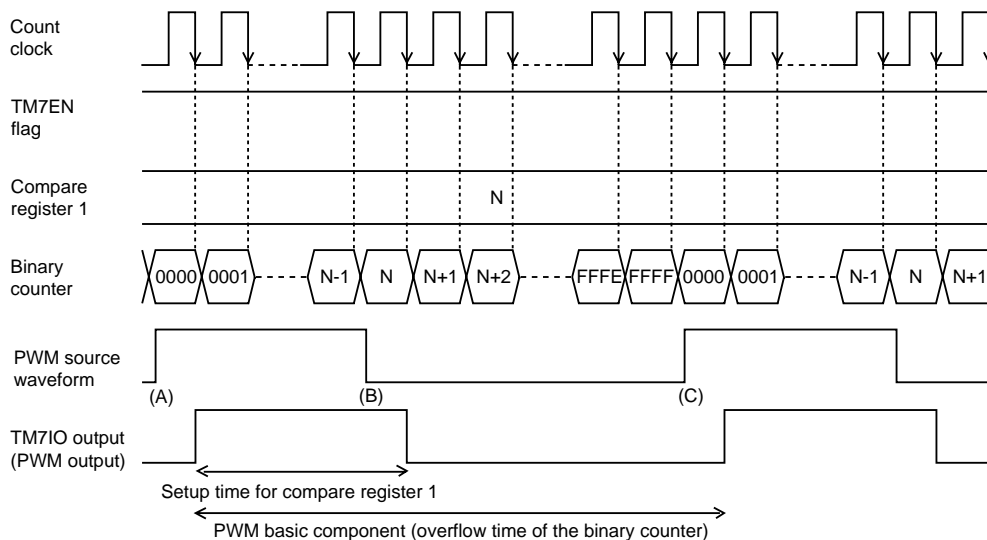
PWM waveform with an arbitrary duty is generated by setting a duty of PWM "H" period to the compare register 1 (TM7OC1). Its cycle is the time of the 16-bit timer full count over flow.

Table 7-6-1 shows the PWM output pin.

**Table 7-6-1 PWM Output Pin**

	Timer 7
PWM output pin	TM7IO output pin (P14)

#### ■Count Timing of Standard PWM Output (at Normal)(Timer 7)



**Figure 7-6-1 Count Timing of Standard PWM Output (at Normal)**

PWM source waveform,

(A) shows "H" till the binary counter reaches the compare register from x'0000'.

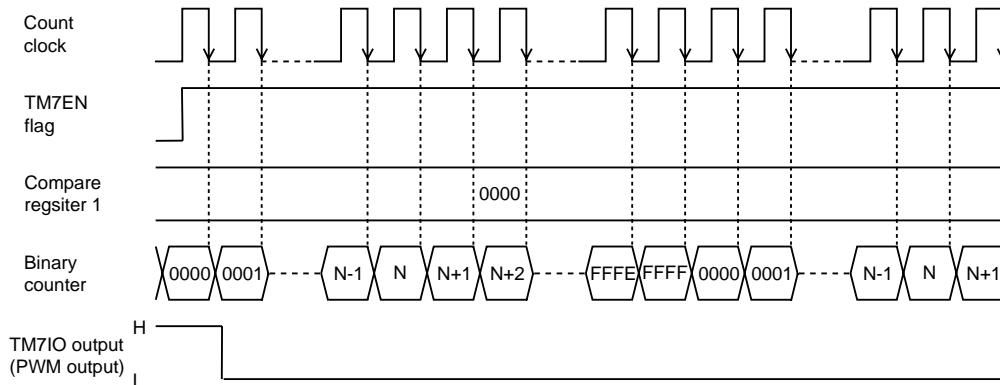
(B) shows "L" after the compare match, then the binary counter counts up till the over flow.

(C) shows "H", again if the binary counter becomes overflow.

The PWM output form pins is 1 count clock delay of PWM source waveform. This is happened to correct the output cycle.

### ■ Count Timing of Standard PWM Output (when Compare Register 1 is x'0000')(Timer 7)

Here is the count timing at setting x'0000' to the compare register 1.

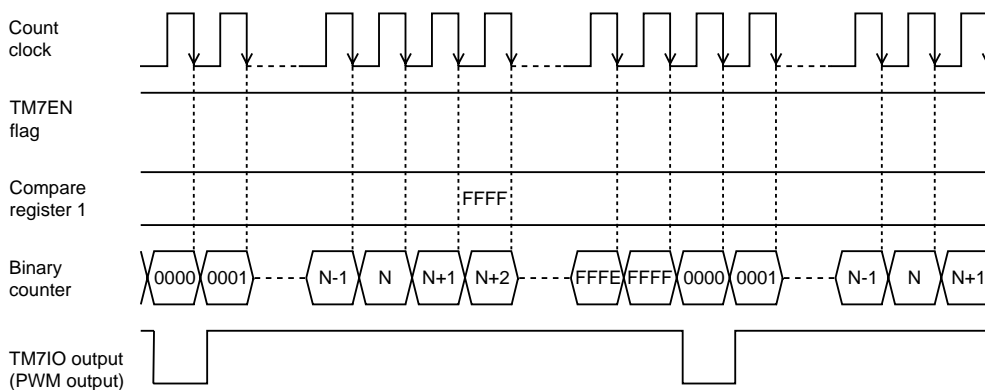


**Figure 7-6-2 Count Timing of Standard PWM Output (when Compare Register 1 is x'0000')**

PWM output shows "H", when TM7EN flag is stopped (at "0").

### ■ Count Timing of Standard PWM Output (when Compare Register 1 is x'FFFF')(Timer 7)

Here is the count timing at setting x'FFFF' to the compare register 1.



**Figure 7-6-3 Count Timing of Standard PWM Output (when Compare Register 1 is x'FFFF')**



When the standard PWM output is operated, set the TM7BCR flag of the TM7MD2 register to "0" to select the full count over flow as a binary counter clear source and a PWM output setup ("H" output) source.



By setting the T7PWMSL flag of the TM7MD2 register, the TM7OC1 compare match or the TM7OC2 compare match can be selected as a PWM output reset ("L" output) source.

## 7-6-2 Setup Example

### ■ Standard PWM Output Setup Example (Timer 7)

The TM7IO output pin outputs the 1/4 duty PWM output waveform at 305.18 Hz with timer 7. The high frequency oscillation (fosc) is set to be operated at 20 MHz. One cycle of the PWM output waveform is decided by the overflow of a binary counter. "H" period of the PWM output waveform is decided by the set value of a compare register 1.

An example setup procedure, with a description of each step is shown below.

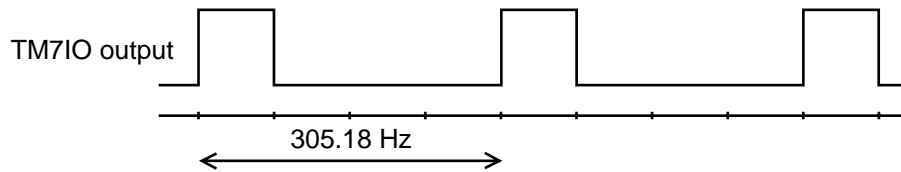



Figure 7-6-4 Output Waveform of TM7IO Output Pin

Setup Procedure	Description
(1) Stop the counter. TM7MD1 (x'3F78') bp4 : TM7EN = 0	(1) Set the TM7EN flag of the timer 7 mode register 1 (TM7MD1) to "0" to stop timer 7 counting.
(2) Set the special function pin to output mode. P1OMD (x'3F2F') bp4 : P1OMD4 = 1 P1DIR (x'3F31') bp4 : P1DIR4 = 1	(2) Set the P1OMD4 flag of the port 1 output mode register (P1OMD) to "1" to set the P14 pin as a special function pin. Set the P1DIR4 flag of the port 1 direction control register (P1DIR) to "1" to set output mode. Add pull-up resistor, if it necessary.  [  Chapter 4 I/O Ports ]
(3) Set the PWM output. TM7MD2 (x'3F79') bp4 : TM7PWM = 1	(3) Set the TM7PWM flag of the timer 7 mode register 2 (TM7MD2) to "1" to select the PWM output.
(4) Set the standard PWM output operation. TM7MD2 (x'3F79') bp5 : TM7BCR = 0	(4) Set the TM7BCR flag of the TM7MD2 register to "0" to select the full count over flow as a binary counter clear source.



Setup Procedure	Description
<p>(5) Select the count clock source.  TM7MD1 (x'3F78')  bp1-0 : TM7CK1-0 = 00  bp3-2 : TM7PS1-0 = 00</p> <p>(6) Set "H" period of the PWM output.  TM7PR1 (x'3F75', x'3F74')=x'4000'</p> <p>(7) Start the timer operation.  TM7MD1 (x'3F78')  bp4 : TM7EN = 1</p>	<p>(5) Select fosc at clock source by the TM7CK1-0 flag of the TM7MD1 register. Also, select 1/1 frequency (no division) at count clock source by the TM7PS1-0 flag.</p> <p>(6) Set "H" period of the PWM output to the timer 7 preset register 1 (TM7PR1). To be a 1/4 duty of the full count (65536), set as follows ;  <math>65536 / 4 = 16384</math> (x'4000')  At that time, the same value is loaded to the timer 7 compare register 1 (TM7OC1) and the timer 7 binary counter (TM7BC) is initialized to x'0000'.</p> <p>(7) Set the TM7EN flag of the TM7MD1 register to "1" to start timer 7.</p>

TM7BC counts up from x'0000'. The PWM source waveform outputs "H" until TM7BC reaches the set value of the TM7OC1 register, then, after the match it outputs "L". After that, TM7BC continues to count up, once overflow happens, the PWM source waveform outputs "H" again, and TM7BC counts up from x'0000', again. TM7IO pin outputs one count clock delay of the PWM source waveform.



In the initial state of the PWM output, it is changed to "H" output from "L" output as the PWM operation is selected by the TM7PWM flag of the TM7MD2 register.

## 7-7 16-bit High Precision PWM Output

### (Cycle/Duty can be changed consecutively)

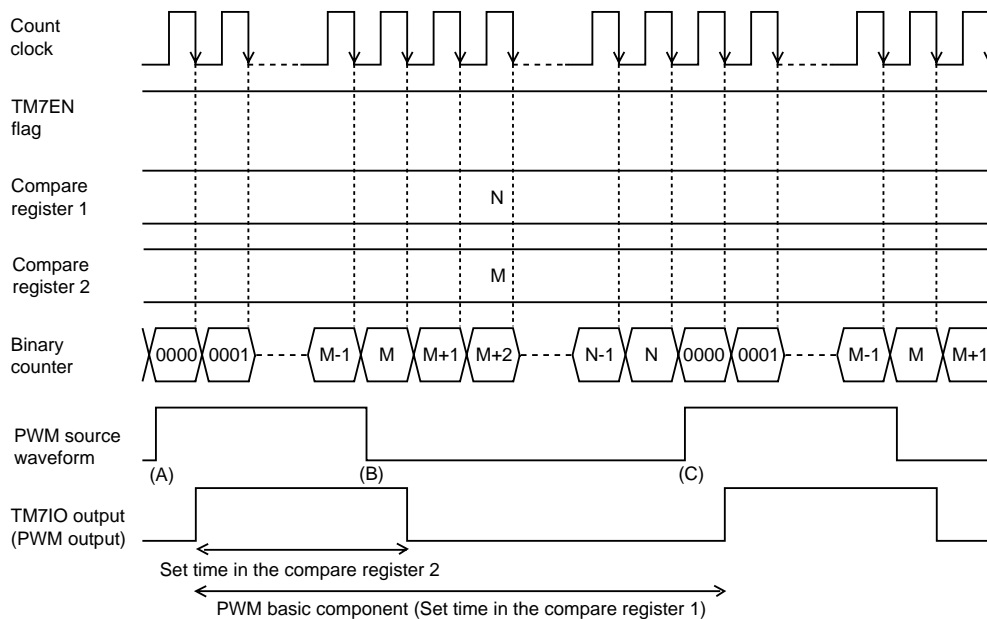
The TM7IO pin outputs high precision PWM output, which is determined by the match timing of the timer binary counter and the compare register 1 and the match timing of the binary counter and the compare register 2.

### 7-7-1 Operation

#### ■16-bit High Precision PWM Output Operation (Timer 7)

The PWM waveform with any cycle/duty is generated by setting the cycle of PWM to the compare register 1 (TM7OC1) and setting the duty of the "H" period to the compare register 2 (TM7OC2). The 16-bit timer that high precision PWM output operation function can be used is timer 7.

#### ■Count Timing of High Precision PWM Output (at Normal) (Timer 7)



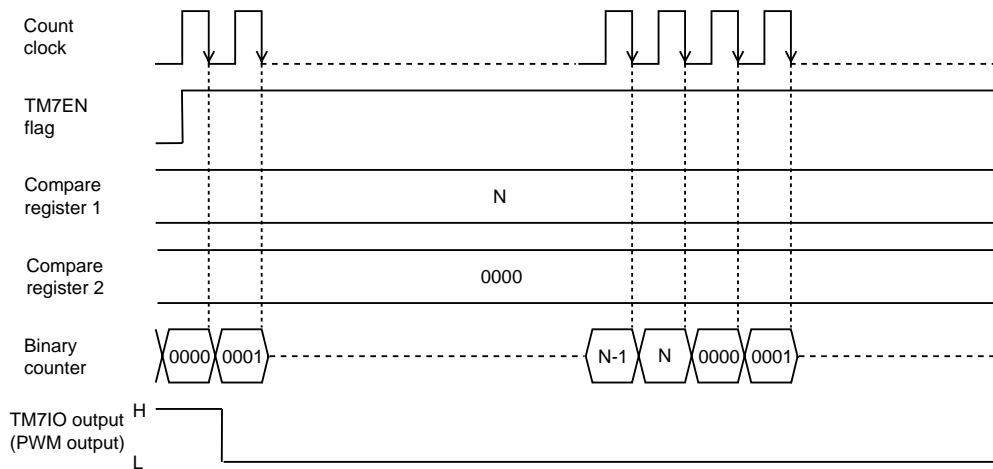
**Figure 7-7-1 Count Timing of High Precision PWM Output (at Normal)**

PWM source waveform,

- (A) is "H" until the binary counter reaches the compare register from x'0000'.
- (B) is "L" after the TM7OC2 compare match, then the binary counter counts up till the binary counter reaches the TM7OC1 compare register to be cleared.
- (C) is "H", again if the binary counter is cleared.

The PWM output from pin is 1 count clock delay of PWM source waveform. This is happened to form inside to correct the output cycle.

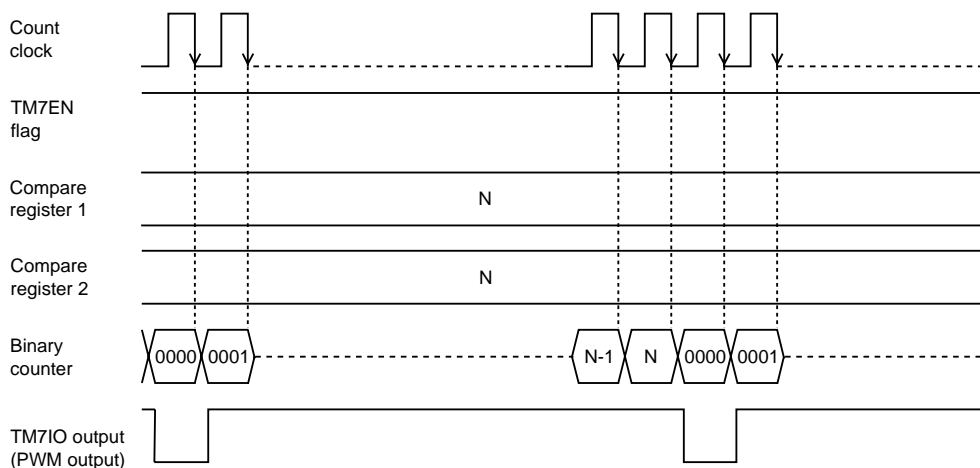
■ Count Timing of High Precision PWM Output (When compare register 2 is x'0000') (Timer 7)  
 Here is the count timing as the compare register 2 is set to x'0000' ;



**Figure 7-7-2 Count Timing of High Precision PWM Output (When compare register 2 is x'0000')**

When the TM7EN flag is stopped (at "0"), the PWM output signal is "H".

■ Count Timing of High Precision PWM Output (at compare register 2 = compare register 1) (Timer 7)  
 Here is the count timing as the compare register 2 is set the same value to the compare register 1 ;



**Figure 7-7-3 Count Timing of High Precision PWM Output (at compare register 2=compare register 1)**



For the high precision PWM output, set the TMBKR flag of the TM7MD2 register to "1" to select the TM7OC1 compare match as a clear source of the binary counter and as a setup ("H" output) source of the PWM output. Also, set the T7PWMSL flag to "1" to select the TM7OC2 compare match as a reset ("L" output) source of the PWM output.

## 7-7-2 Setup Example

### ■High Precision PWM Output Setup Example (Timer 7)

The TM7IO output pin outputs the 1/4 duty PWM output waveform at 400 Hz with timer 7. Select fosc/2 (at fosc = 20 MHz) as a clock source. One cycle of the PWM output waveform is decided by the set value of a compare register 1. "H" period of the PWM output waveform is decided by the set value of a compare register 2.

An example setup procedure, with a description of each step is shown below.

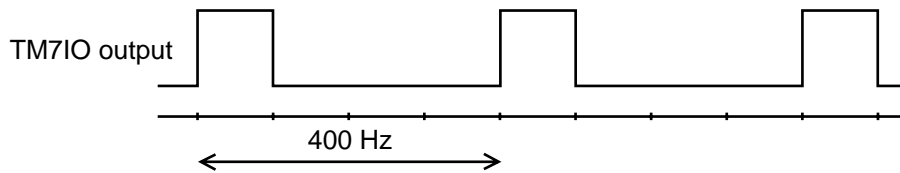



Figure 7-7-4 Output Waveform of TM7IO Output Pin

Setup Procedure	Description
<p>(1) Stop the counter.                      TM7MD1 (x'3F78')                      bp4 : TM7EN = 0</p>	<p>(1) Set the TM7EN flag of the timer 7 mode register 1 (TM7MD1) to "0" to stop timer 7 counting.</p>
<p>(2) Set the special function pin to output mode.                      P1OMD (x'3F2F')                      bp4 : P1OMD4 = 1                      P4DIR (x'3F31')                      bp4 : P1DIR4 = 1</p>	<p>(2) Set the P1OMD4 flag of the port 1 output mode register (P1OMD) to "1" to set the P14 pin as a special function pin. Set the P1DIR4 flag of the port 1 direction control register (P1DIR) to "1" for output mode.                      Add pull-up resistor, if it necessary.                      [  Chapter 4 I/O Ports ]</p>
<p>(3) Set the PWM output.                      TM7MD2 (x'3F79')                      bp4 : TM7PWM = 1</p>	<p>(3) Set the TM7PWM flag of the timer 7 mode register 2 (TM7MD2) to "1" to select the PWM output.</p>
<p>(4) Set the high precision PWM output operation.                      TM7MD2 (x'3F79')                      bp5 : TM7BCR = 1                      bp6 : T7PWMSL = 1</p>	<p>(4) Set the TM7BCR flag of the TM7MD2 register to "1" to select the TM7OC1 compare match as a clear source of binary counter.                      Also, set the T7PWMSL flag to "1" to select the TM7OC2 compare match as a duty decision source of the PWM output.</p>

Setup Procedure	Description
<p>(5) Select the count clock source.            TM7MD1 (x'3F78')                bp1-0 : TM7CK1-0 = 00                bp3-2 : TM7PS1-0 = 01</p>	<p>(5) Select fosc as clock source by the TM7CK1-0 flag of the TM7MD1 register. Also, select 1/2 dividing as count clock source by the TM7PS1-0 flag.</p>
<p>(6) Set the PWM output cycle.            TM7PR1 (x'3F75',x'3F74') = x'61a7'</p>	<p>(6) Set the PWM output cycle to the timer 7 preset register 1 (TM7PR1). To be 400 Hz by divided 10 MHz, set as follows :  <math>25000 - 1 = 24999</math> (x'61a7')</p> <p>At that time, the same value is loaded to the timer 7 compare register 1 (TM7OC1), and the timer 7 binary counter (TM7BC) is initialized to x'0000'.</p>
<p>(7) Set the "H" period of the PWM output.            TM7PR2 (x'3F7D',x'3F7C')=x'186a'</p>	<p>(7) Set the "H" period of the PWM output to the timer 7 preset register 2 (TM7PR2). To be a 1/4 duty of 25000 dividing, set as follows ;  <math>25000 / 4 = 6250</math> (x'186a')</p> <p>At that time, the same value is loaded to the timer 7 compare register 2 (TM7OC2).</p>
<p>(8) Start the timer operation.            TM7MD1 (x'3F78')                bp4 : TM7EN = 1</p>	<p>(8) Set the TM7EN flag of the TM7MD1 register to "1" to start timer 7.</p>

TM7BC counts up from x'0000'. The PWM source waveform outputs "H" until TM7BC matches the set value of the TM7OC2 register. Once they matches, it outputs "L". After that, TM7BC continues to count up, once TM7BC matches the TM7OC1 register to be cleared, the PWM source waveform outputs "H" again and TM7BC counts up from x'0000' again. TM7IO pin outputs one count clock delay of the PWM source waveform.



In the initial state of the PWM output, it is changed from "L" output to "H" output as the PWM output is selected by the TM7PWM flag of the TM7MD register.



Set as the set value of TM7OC2  $\leq$  the set value of TM7OC1. If it is set as the set value of TM7OC2  $>$  the set value of TM7OC1, the PWM output is a "H" fixed output.

## 7-8 16-bit Timer Synchronous Output

### 7-8-1 Operation

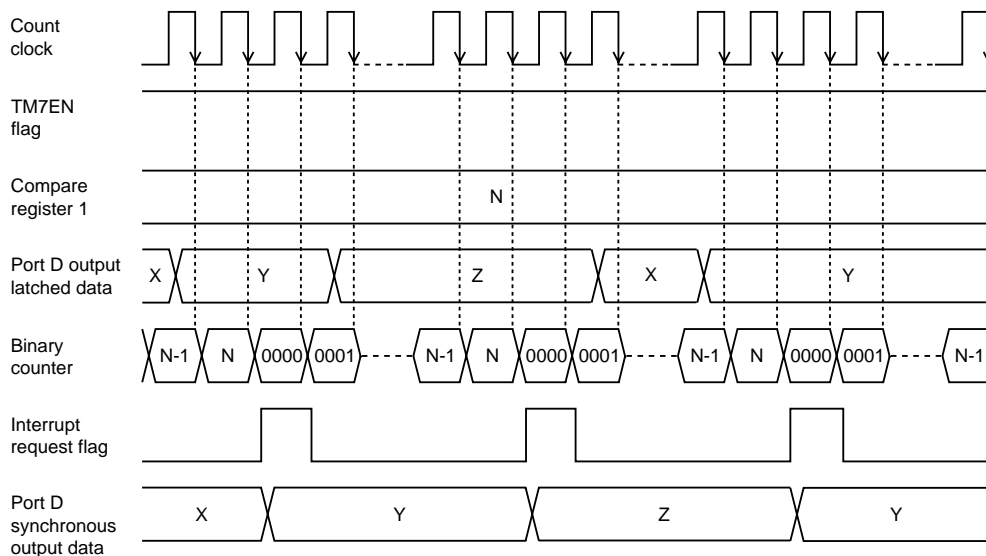
When the binary counter of the timer reaches the set value of the compare register, the latched data is output from port D at the next count clock.

#### ■ Synchronous Output Operation by 16-bit Timer (Timer 7)

The port D latched data is output from the output pin at the interrupt request generation by the match of the binary counter (TM7OC1) or by the full count overflow.

Only port D can perform synchronous output operation, and individual pins can be set.

#### ■ Count Timing of Synchronous Output (Timer 7)



**Figure 7-8-1 Count Timing of Synchronous Output (Timer 7)**


The port D latched data is output from the output pin in synchronization with the interrupt request generation by the match of a binary counter and a compare register 1.

## 7-8-2 Setup Example

### ■ Synchronous Output Setup Example (Timer 7)

Setup example that latched data of port 7 is output constantly (100  $\mu$ s) by using timer 7 from the synchronous output pin is shown below. The clock source of timer 7 is selected fs/4 (at fosc=8 MHz).

An example setup procedure, with a description of each step is shown below.

Setup Procedure	Description
(1) Stop the counter. TM7MD1 (x'3F78') bp4 : TM7EN = 0	(1) Set the TM7EN flag of the timer 7 mode register 1 (TM7MD1) to "0" to stop timer 7 counting.
(2) Select the synchronous output event. FLOAT (x'3F2E') bp1-0 : SYOEVS1-0 = 01	(2) Set the SYOEVS1-0 flag of the pin control register (FLOAT) to "01" to set the synchronous output event to the timer 7 interrupt.
(3) Set the synchronous output pin. PDSYO (x'3F1F') = x'FF' PDDIR (x'3F3D') = x'FF'	(3) Set the port D synchronous output control register (PDSYO) to x'FF' to set the synchronous output pin. (PD7 to PD0 : Synchronous output pin) Set the port D direction control register (PDDIR) to x'FF' to set port D to output pin. If it needs, pull-up resistor should be added. [  Chapter 4 I/O Ports ]
(4) Select the condition of timer clear. TM7MD2 (x'3F79') bp5 : TM7BCR = 1	(4) Set the TM7BCR flag of the TM7MD2 register to "1" to select the compare match as a clear source of the binary counter.
(5) Select the count clock source. TM7MD1 (x'3F78') bp1-0 : TM7CK1-0 = 01 bp3-2 : TM7PS1-0 = 10	(5) Select fs as a clock source by the TM7CK1-0 flag of the TM7MD 1 register. Also, select a 1/4 dividing as a clock source by the TM7PS1-0 flag.
(6) Set the synchronous output event generation cycle. TM7PR1 (x'3F75',x'3F74')=x'0063'	(6) Set the synchronous output event generation cycle to the timer 7 preset register 1 (TM7PR1). To be 10 kHz by dividing 1 MHz, set as follows ; 100 - 1 = 99 (x'0063') At that time, the same value is loaded to the timer 7 compare register 1 (TM7OC1), and TM7BC is initialized to x'0000'.

Setup Procedure	Description
(7) Start the timer operation. TM7MD1 (x'3F78') bp4 : TM7EN = 1	(7) Set the TM7EN flag of the TM7MD1 register to "1" to start timer 7.

TM7BC counts up from x'0000'. If any data is written to the port D output register (PDOUT), TM7BC reaches the set value of TM7OC1 register and the synchronous output pin outputs data of port D in every time an interrupt request is generated.



## 7-9 16-bit Timer Capture

### 7-9-1 Operation

The value of a binary counter is stored to register at the timing of the external interrupt input signal, or the timing of writing operation with an arbitrary value to the capture register.

#### ■ Capture Operation with External Interrupt Signal as a Trigger (Timer 7)

Capture trigger of input capture function is generated at the external interrupt signal that passed through the external interrupt interface block. The capture trigger is selected by the timer 7 mode register 2 (TM7MD2) and the external interrupt control register (IRQ0ICR, IRQ1ICR, IRQ2ICR, IRQ3ICR).

Here are the capture trigger to be selected and the interrupt flag setup.

**Table 7-9-1 Capture Trigger**

Capture trigger source	Timer 7 mode register 2		External interrupt n control register (IRQnICR)	Both edges interrupt control register (EDGDT)		Interrupt starting edge of external interrupt n
	T7ICT1-0	T7ICEDG	REDGn (bp5)	EDGSEL3	EDGSEL2	
IRQ0 falling edge	00(IRQ0)	1	0	-	-	IRQ0 falling edge
IRQ0 rising edge	00(IRQ0)	1	1	-	-	IRQ0 rising edge
IRQ0 both edge	00(IRQ0)	0	0	-	-	IRQ0 falling edge
			1	-	-	IRQ0 rising edge
IRQ1 falling edge	01(IRQ1)	1	0	-	-	IRQ1 falling edge
IRQ1 rising edge	01(IRQ1)	1	1	-	-	IRQ1 rising edge
IRQ1 both edge	01(IRQ1)	0	0	-	-	IRQ1 falling edge
			1	-	-	IRQ1 rising edge
IRQ2 falling edge	10(IRQ2)	1	0	-	0	IRQ2 falling edge
IRQ2 rising edge	10(IRQ2)	1	1	-	0	IRQ2 rising edge
IRQ2 both edge(*)	10(IRQ2)	0	0	-	0	IRQ2 falling edge
			1	-	0	IRQ2 rising edge
IRQ3 falling edge	11(IRQ3)	1	0	0	-	IRQ3 falling edge
IRQ3 rising edge	11(IRQ3)	1	1	0	-	IRQ3 rising edge
IRQ3 both edge(*)	11(IRQ3)	0	0	0	-	IRQ3 falling edge
			1	0	-	IRQ3 rising edge



The external interrupt 2 (IRQ2) and the external interrupt 3 (IRQ3) has the function of both edges interrupt. But, that function cannot be used when the input capture should be generated at both edges. [table 7-9-1(\*)]

When capture trigger is activated at both edges of an external interrupt, the high precision pulse width measurement that measures the width of "H" period and "L" period of input signal constantly, is possible

with the automatic data transfer function (ATC1). In the transfer mode 5 of ATC1, set the address of the input capture register TM7ICL to the memory pointer 1. The "H" period and "L" period of the input signal can be measured by transferring the value of the input capture register (TM7ICL, TM7ICH) to memory in every generation of a capture trigger.

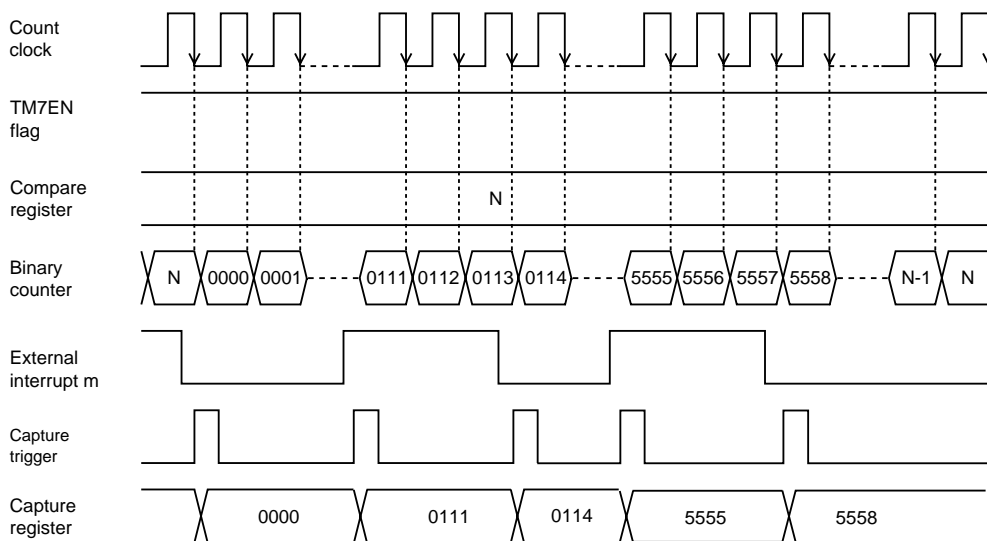
An interrupt request and a capture trigger are generated at switching the valid edge of an external interrupt by program, when the setup is as follows ;

- (1) at switching the valid edge from the falling to the rising, when the interrupt pin is "H" level.
- (2) at switching the valid edge from the rising to the falling, when the interrupt pin is "L" level.

This is not happened, if the interrupt edge is switched after the generation of an valid edge interrupt set in advance. But when the both edges interrupt function is used, this may be happened. Be sure to consider the noise influence for operation of the interrupt flag on program.


[  Chapter 3 3-3-4. Programmable active Edge Interrupt ]


■ Capture Count Timing at a Both Edges of External Interrupt Signal is selected as a Trigger (Timer 7)



**Figure 7-9-1 Capture Count Timing at an External Interrupt Signal is selected as a Trigger (Timer 7)**

A capture trigger is generated at the both edges of the external interrupt m input signal. At the same timing, the value of a binary counter is stored to the input capture register. That value is decided by the value of a binary counter at the falling edge of a capture trigger. When the specified edge is selected as a capture trigger generation source, a capture trigger is generated at the interrupt generation specified edge, only. The other count timing is same to the count timing of the timer operation.

 When the binary counter is used as a free counter that counts 'x'0000' to 'x'FFFF', set the compare register 1 to 'x'FFFF', or set the TM7BCR flag of the TM7MD2 register to "0".

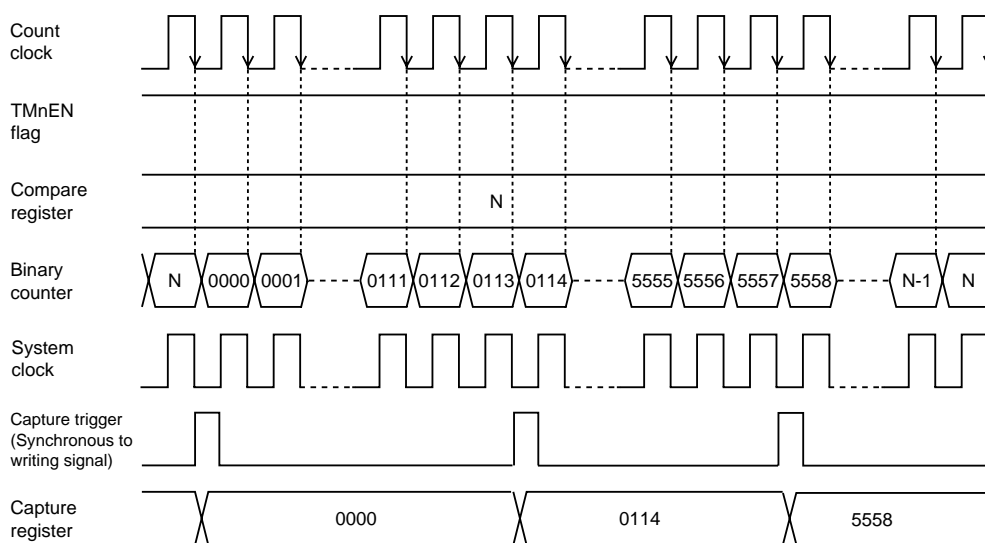
 Even if a capture trigger is generated before the value of the input capture register is read out, the value of the input capture register can be rewritten.



In the initial state after releasing the reset, the generation of trigger by the external interrupt signal is disabled. Set the T7ICEN flag of the TM7MD2 register to "1" to enable the trigger generation.

#### ■ Capture Operation that the writing to program is selected as a Trigger (Timer 7)

A capture trigger can be generated by writing an arbitrary value to the input capture register (TM7IC), and at the same timing, the value of the binary counter can be stored to the input capture register.



**Figure 7-9-2 Capture Count Timing  
with a Writing Signal to Program as a Trigger (Timer 7)**

A capture trigger is generated at the writing signal to the input capture register. The writing signal is generated at the last cycle of the writing instruction. At this timing, the value of the binary counter is stored to the input capture register. That value is decided by the value of the binary counter at the falling edge of the capture trigger. The other timing is same to the timer operation.



The writing to the input capture register to generate a capture trigger should be done with a 8-bit access instruction to the TM7ICL register or the TM7ICH register. At this time, data is not actually written to the TM7IC register.



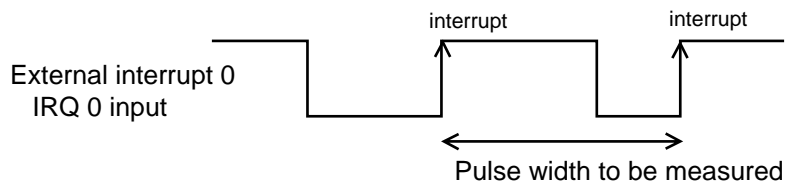
On hardware, there is no flag to disable the capture operation with the writing operation to the software as a trigger. Capture operation is enabled, regardless of the T7ICEN flag of the TM7MD2 register.

## 7-9-2 Setup Example

### ■ Capture Function Setup Example (Timer 7)


Pulse width measurement is enabled by storing the value of the binary counter to the capture register at the interrupt generation edge of the external interrupt 0 input signal with timer 7. The interrupt generation edge is specified to be the rising edge.

An example setup procedure, with a description of each step is shown below.



**Figure 7-9-3 Pulse Width Measurement of External Interrupt 0**

Setup Procedure	Description
(1) Stop the counter. TM7MD1 (x'3F78') bp4 : TM7EN = 0	(1) Set the TM7EN flag of the timer 7 mode register 1 (TM7MD1) to "0" to stop timer 7 counting.
(2) Select the condition for timer clear. TM7MD2 (x'3F79') bp5 : TM7BCR = 1	(2) Set the TM7BCR flag of the timer 7 mode register 2 (TM7MD2) to "1" to select the compare match as a clear source of binary counter.
(3) Select the count clock source. TM7MD1 (x'3F78') bp1-0 : TM7CK1-0 = 00 bp3-2 : TM7PS1-0 = 00	(3) Select fosc as clock source by the TM7CK1-0 flag of the TM7MD1 register. And select 1/1 (no dividing) of fosc as count clock source by the TM7PS1-0 flag.
(4) Select the capture trigger generation interrupt source. TM7MD2 (x'3F79') bp1-0 : T7ICT1-0 = 00	(4) Select the external interrupt 0 (IRQ0) input as a generation source of capture trigger by the T7ICT1-0 flag of the TM7MD2 register.
(5) Select the interrupt generation valid edge. IRQ0ICR (x'3FE2') bp5 : REDG0 = 1	(5) Set the REDG0 flag of the external interrupt 0 control register (IRQ0ICR) to "1" to select the rising edge as the interrupt generation valid edge.

Setup Procedure	Description
(6) Select the capture trigger generation edge. TM7MD2 (x'3F79') bp7 : T7ICEDG = 1	(6) Set the T7ICEDG flag of the TM7MD2 register to "1" to select the external interrupt valid edge as a generation source of capture trigger.
(7) Set the compare register. TM7PR1(x'3F75',x'3F74') = x'FFFF'	(7) Set the timer 7 preset register 1 (TM7PR1) to x'FFFF'. At that time, the same value is loaded to the timer 7 compare register 1 (TM7OC1), and the timer 7 binary counter (TM7BC) is initialized to x'0000'.
(8) Set the interrupt level. IRQ0ICR (x'3FE2') bp7-6 : IRQ0LV1-0 = 10	(8) Set the interrupt level by the IRQ0LV1-0 flag of the IRQ0ICR register. If any interrupt request flag may be set already, clear them. [  Chapter 3 3-1-4. Interrupt Flag Setup ]
(9) Enable the interrupt. IRQ0ICR (x'3FE2') bp1 : IRQ0IE = 1	(9) Enable the interrupt by setting the IRQ0IE flag of the IRQ0ICR register to "1".
(10) Enable the capture trigger generation. TM7MD2 (x'3F79') bp2 : T7ICEN = 1	(10) Enable the capture trigger generation by setting the T7ICEN flag of the TM7MD2 register to "1".
(11) Start the timer operation. TM7MD1 (x'3F78') bp4 : TM7EN = 1	(11) Set the TM7EN flag of the TM7MD1 register to "1" to start timer 7.

TM7BC counts up from x'0000'. At the timing of the rising edge of the external interrupt 0 input signal, the value of TM7BC is stored to the TM7IC register. And at that time, the pulse width between rising edges of the external interrupt input signal can be measured by reading the value of TM7IC register by the interrupt service routine, and by calculating the margin of the capture values (the values of the TM7IC register).



Chapter 8 Time Base Timer /  
8-bit Free-running Timer

# 8-1 Overview


This LSI has a time base timer and a 8-bit free-running timer (timer 6).

Time base timer is a 15-bit timer counter. These timers can stop the timer counting only at stand-by mode (STOP mode).

## 8-1-1 Functions

Table 8-1-1 shows the clock sources and the interrupt generation cycles that timer 6 and time base timer can select.

**Table 8-1-1 Clock Source and Generation Cycle**

	Time base timer	Timer 6 (8-Bit free-running timer)
8-bit timer operation	-	√
Interrupts / source	TBIRQ	TM6IRQ
Clock source	fosc fx	fosc fx fs fosc X 1/2 <sup>12</sup> (*1) fosc X 1/2 <sup>13</sup> (*1) fx X 1/2 <sup>12</sup> (*2) fx X 1/2 <sup>13</sup> (*2)
Interrupt generation cycle	fosc X 1/2 <sup>7</sup> (*1) fosc X 1/2 <sup>8</sup> (*1) fosc X 1/2 <sup>9</sup> (*1) fosc X 1/2 <sup>10</sup> (*1) fosc X 1/2 <sup>13</sup> (*1) fosc X 1/2 <sup>15</sup> (*1) fx X 1/2 <sup>7</sup> (*2) fx X 1/2 <sup>8</sup> (*2) fx X 1/2 <sup>9</sup> (*2) fx X 1/2 <sup>10</sup> (*2) fx X 1/2 <sup>13</sup> (*2) fx X 1/2 <sup>15</sup> (*2)	The interrupt generation cycle is decided by the arbitrary value written to TM6OC.
fosc : Machine clock (High speed oscillation) fx : Machine clock (Low speed oscillation) fs : System clock [  Chapter 2 2-5. Clock Switching ] - *1 can be used as a clock source of time base timer is selected to 'fosc'. - *2 can be used as a clock source of time base timer is selected to 'fx'. - Time base timer and timer 6 cannot stop timer 6 counting.		



## 8-1-2 Block Diagram

### ■Timer 6, Time Base Timer Block Diagram

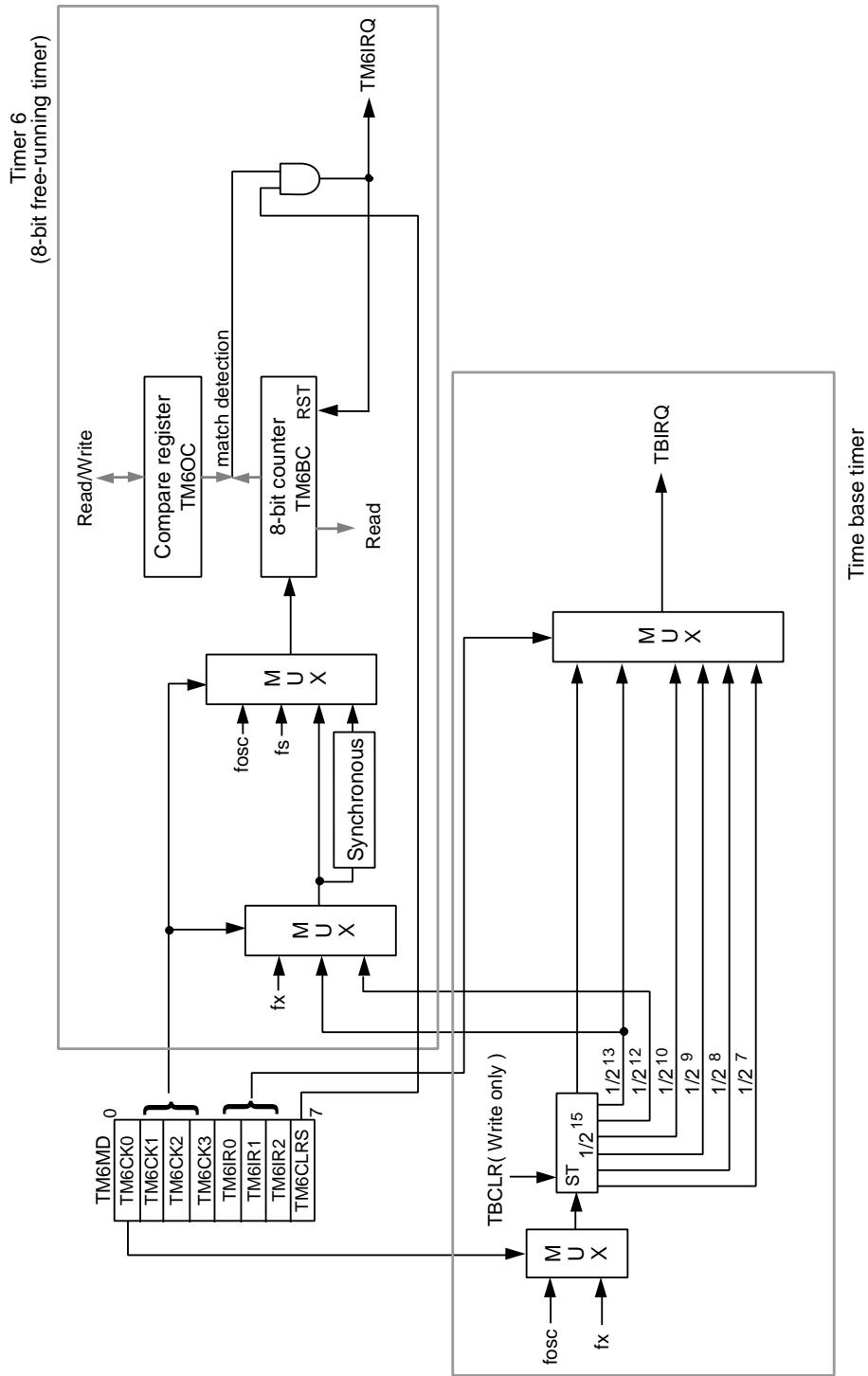


Figure 8-1-1 Block Diagram (Timer 6, Time Base Timer)

## 8-2 Control Registers

Timer 6 consists of binary counter (TM6BC), compare register (TM6OC), and is controlled by mode register (TM6MD). Time base timer is controlled by mode register (TM6MD) and time base timer clear register (TBCLR), too.

### 8-2-1 Control Registers

Table 8-2-1 shows the registers that control timer 6, time base timer.

**Table 8-2-1 Control Registers**

	Register	Address	R/W	Function	Page
Timer 6	TM6BC	x'03F68'	R	Timer 6 binary counter	VIII - 5
	TM6OC	x'03F69'	R/W	Timer 6 compare register	VIII - 5
	TM6MD	x'03F6A'	R/W	Timer 6 mode register	VIII - 6
	TM6ICR	x'03FEF'	R/W	Timer 6 interrupt control register	III - 29
Timer base timer	TM6MD	x'03F6A'	R/W	Timer 6 mode register	VIII - 6
	TBCLR	x'03F6B'	W	Time base timer clear control register	VIII - 5
	TBICR	x'03FF0'	R/W	Time base interrupt control register	III - 30

R/W : Readable / Writable

R : Readable only

W : Writable only

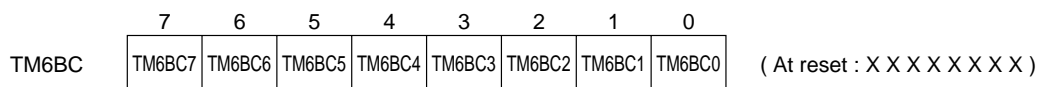
## 8-2-2 Programmable Timer Registers

Timer 6 is a 8-bit programmable counter.

Programmable counter consists of compare register (TM6OC) and binary counter (TM6BC).

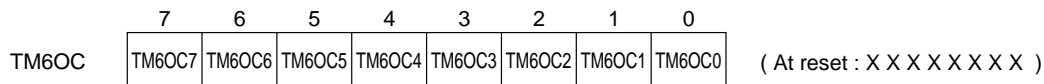
Binary counter is a 8-bit up counter. When the TM6CLRS flag of the timer 6 mode register (TM6MD) is "0" and the interrupt cycle data is written to the compare register (TM6OC), the timer 6 binary counter (TM6BC) is cleared to x'00'.

### ■Timer 6 Binary Counter (TM6BC)



**Figure 8-2-1 Timer 6 Binary Counter (TM6BC : x'03F68', R)**

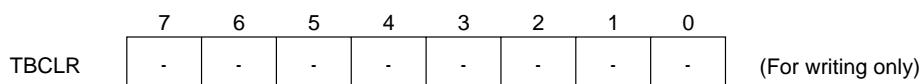
### ■Timer 6 Compare Register (TM6OC)



**Figure 8-2-2 Timer 6 Compare Register (TM6OC : x'03F69', R/W)**

Time base timer cannot stop counting but the software can reset its operation. Time base timer can be cleared by writing an arbitrary value to the time base timer clear control register (TBCLR).

### ■Time Base Timer Clear Control Register (TBCLR)

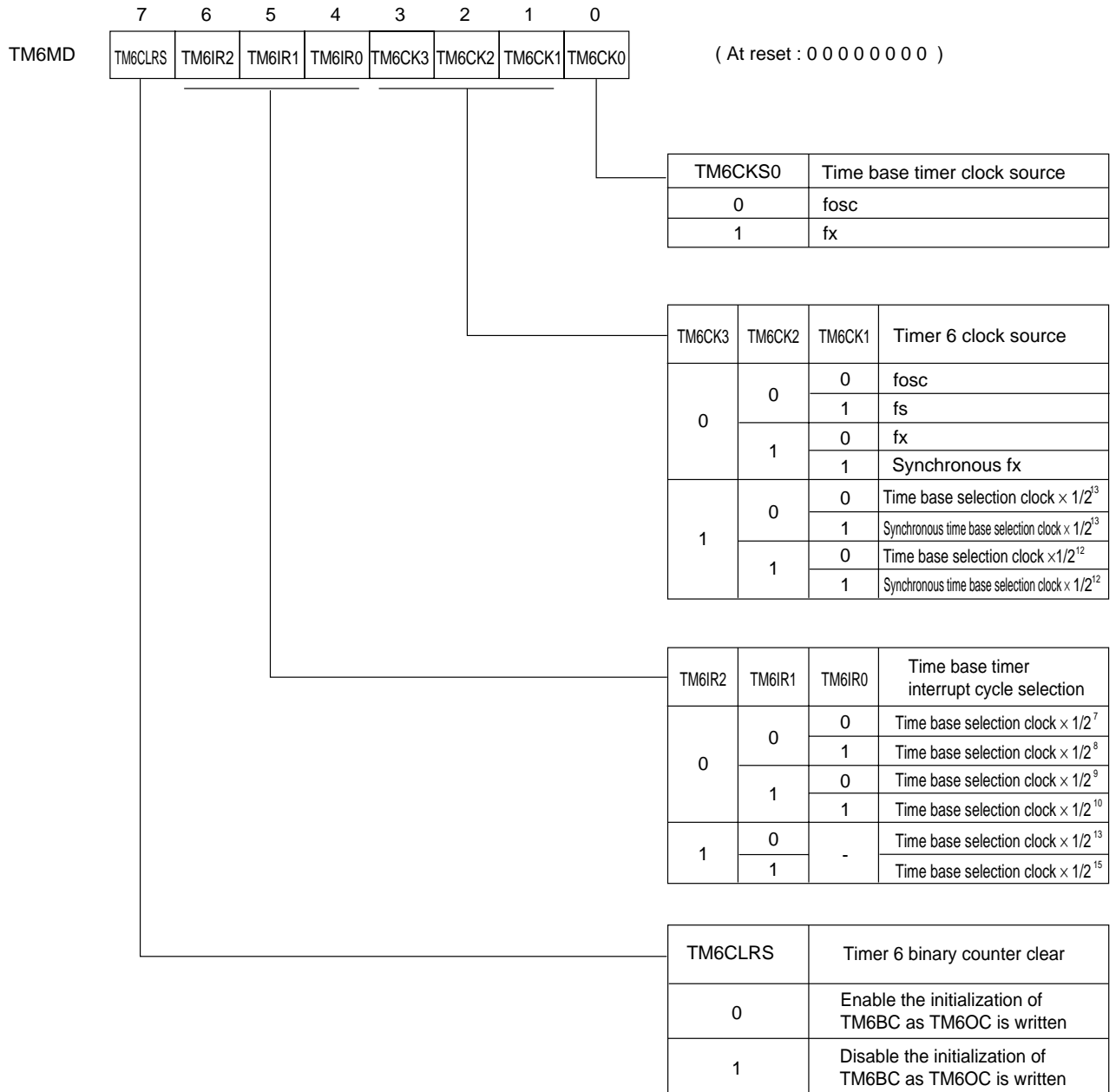


**Figure 8-2-3 Time Base Timer Clear Control Register (TBCLR : x'03F6B')**

### 8-2-3 Timer Mode Registers

This is a readable / writable register that controls timer 6 and time base timer.

■Timer 6 Mode Register (TM6MD)



\* TM6IRQ is disabled as TM6CLRS = 0, TM6IRQ is enabled as TM6CLRS = 1.

Figure 8-2-4 Timer 6 Mode Register (TM6MD : x'03F6A', R/W)

## 8-3 8-bit Free-running Timer

### 8-3-1 Operation

#### ■8-bit Free-running Timer (Timer 6)

The generation cycle of the timer interrupt is set by the clock source selection and the setting value of the compare register (TM6OC), in advance. If the binary counter (TM6BC) reaches the setting value of the compare register, an interrupt is generated at the next count clock, then the binary counter is cleared and counting is restarted from x'00'.

Table 8-3-1 shows clock source that can be selected.

**Table 8-3-1 Clock Source at Timer Operation (Timer 6)**

Clock source	1count time
fosc	50 ns
fx	30.5 $\mu$ s
fs	100 ns
fosc X 1/2 <sup>12</sup>	204.8 $\mu$ s
fosc X 1/2 <sup>13</sup>	409.6 $\mu$ s
fx X 1/2 <sup>12</sup>	125 ms
fx X 1/2 <sup>13</sup>	250 ms
Notes : as fosc = 20(MHz) fx = 32.768(kHz) fs = fosc/2 = 10 MHz	



Timer 6 cannot stop its timer counting except at stanby mode (STOP mode).

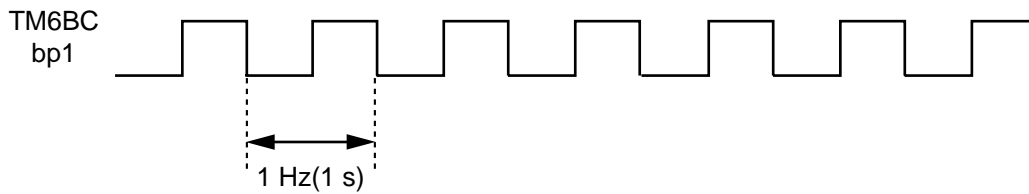
■8-bit Free-running Timer as a 1 minute-timer, a 1 second-timer

Table 8-3-2 shows the clock source selection and the TM6OC register setup, when a 8-bit free-running timer is used as a 1 minute-timer, a 1 second-timer.

**Table 8-3-2 1 minute-timer, 1 second-timer Setup (Timer 6)**

Interrupt Generation Cycle	Clock Source	TM6OC Register
1 min	$f_x \times 1/2^{13}$	X'EF'
1 s	$f_x \times 1/2^{12}$	X'07'
	$f_x \times 1/2^{13}$	X'03'
fx = 32.768(kHz)		

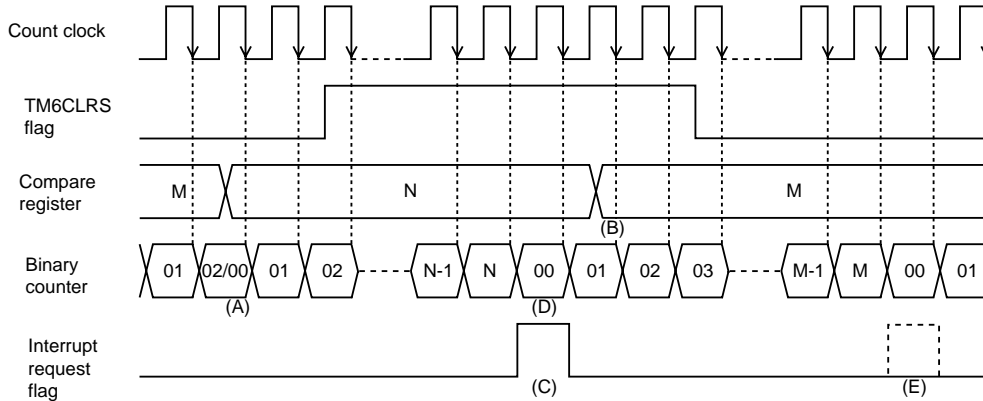
When the 1 minute-timer (1 min.) is set on Table 8-3-2, the bp1 waveform frequency (cycle) of the TM6BC register is 1 Hz (1 s). So, that can be used for adjusting the seconds.



**Figure 8-3-1 Waveform of TM6BC Register bp1 (Timer 6)**

■ Count Timing of Timer Operation (Timer 6)

Binary counter counts up with the selected clock source as a count clock.



**Figure 8-3-2 Count Timing of Timer Operation (Timer 6)**

- (A) When any data is written to the compare register as the TM6CLRS flag is "0", the binary counter is cleared to x'00'.
- (B) Even if any data is written to the compare register as the TM6CLRS flag is "1", the binary counter is not changed.
- (C) When the binary counter reaches the value of the compare register as the TM6CLRS flag is "1", an interrupt request flag is set at the next count clock.
- (D) When an interrupt request flag is set, the binary counter is cleared to x'00' and restarts the counting.
- (E) Even if the binary counter reaches the value of the compare register as the TM6CLRS flag is "0", no interrupt request flag is set.

When the binary counter reaches the value in the compare register, the interrupt request flag is set and the binary counter is cleared, at the next count clock.  
So, set the compare register as :  
Compare register setting = (count till the interrupt request - 1)

If fx is selected as the count clock source in timer 6, when the binary counter is read at operation, uncertain value on counting up may be read. To prevent this, select the synchronous fx as the count clock source.  
But if the synchronous fx is selected as the count clock source, CPU mode cannot return from STOP/HALT mode.


If the compare register is set smaller than the binary counter during the count operation, the binary counter counts up to the overflow, at first.

## 8-3-2 Setup Example

### ■Timer Operation Setup (Timer 6)

Timer 6 generates an interrupt constantly for timer function.  $F_s$ ( $f_{osc} = 20 \text{ MHz}$ ) is selected as a clock source to generate an interrupt every 250 cycles (25  $\mu\text{s}$ ).

An example setup procedure, with a description of each step is shown below.

Setup Procedure	Description
(1) Enable the binary counter initialization. TM6MD (x'3F6A') bp7 : TM6CLRS = 0	(1) Set the TM6LRS flag of the timer 6 mode register (TM6MD) to "0". At that time, the initialization of the timer 6 binary counter (TM6BC) is enabled.
(2) Select the clock source. TM6MD (x'3F6A') bp3-1 : TM6CK3-1 = 001	(2) Clock source can be selected by the TM6CK3-1 flag of the TM6MD register. Actually, $f_s$ is selected.
(3) Set the interrupt generation cycle. TM6OC (X'3F69') = x'F9'	(3) Set the interrupt generation cycle to the timer 6 compare register (TM6OC). At that timer, TM6BC is initialized to x'00'.
(4) Enable the interrupt request generation. TM6MD (x'3F6A') bp7 : TM6CLRS = 1	(4) Set the TM6CLRS flag of the TM6MD register to "1" to enable the interrupt request generation.
(5) Set the interrupt level. TM6ICR (x'3FEF') bp7-6 : TM6LV1-0 = 01	(5) Set the interrupt level by the TM6LV1-0 flag of the timer 6 interrupt control register (TM6ICR). If the interrupt request flag may be already set, clear them.
(6) Enable the interrupt. TM6ICR (x'3FEF') bp1 : TM6IE = 1	(6) Set the TM6IE flag of the TM6ICR register to "1" to enable the interrupt. [  Chapter 3 3-1-4. Interrupt Flag Setup ]

\* the above steps (1), (2) can be set at once.

As TM6OC is set, TM6BC is initialized to x'00' to count up.

When TM6BC matches TM6OC, the timer 6 interrupt request flag is set to "1" at the next count clock and TM6BC is cleared to x'00' to restart counting.





If the TM6CLRS flag of the TM6MD register is set to "0", TM6BC can be initialized in every rewriting of TM6OC register, but in that state the timer 6 interrupt is disabled. If the timer 6 interrupt should be enabled, set the TM6CLRS flag to "1" after rewriting the TM6OC register.



On the timer 6 clock source selection, either the time base timer output or the time base timer synchronous output is selected, the clock setup of time base timer is needed.

## 8-4 Time Base Timer

### 8-4-1 Operation

■Time Base Timer (Time Base Timer)

The Interrupt is constantly generated.

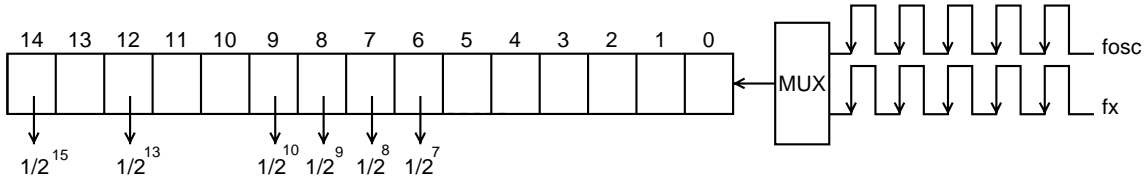
Table 8-4-1 shows the interrupt generation cycle in combination with the clock source ;

**Table 8-4-1 Time Base Timer Interrupt Generation Cycle**

Selected clock source	Interrupt generation cycle	
fosc	$fosc \times 1/2^7$	6.4 $\mu$ s
	$fosc \times 1/2^8$	12.8 $\mu$ s
	$fosc \times 1/2^9$	25.6 $\mu$ s
	$fosc \times 1/2^{10}$	51.2 $\mu$ s
	$fosc \times 1/2^{13}$	409.6 $\mu$ s
	$fosc \times 1/2^{15}$	1.64 ms
fx	$fx \times 1/2^7$	3.9 ms
	$fx \times 1/2^8$	7.8 ms
	$fx \times 1/2^9$	15.6 ms
	$fx \times 1/2^{10}$	31.2 ms
	$fx \times 1/2^{13}$	250 ms
	$fx \times 1/2^{15}$	1 s
fosc = 20(MHz) fx = 32.768(kHz)		

### ■ Count Timing of Timer Operation (Time Base Timer)

The counter counts up with the selected clock source as a count clock.



**Figure 8-4-1 Count Timing of Timer Operation (Time Base Timer)**

When the selected interrupt cycle has passed, the interrupt request flag of the time base interrupt control register (TBICR) is set to "1".



An interrupt may be generated at switching of the clock source. Enable interrupt after switching the clock source.




Time base timer cannot stop the operation.  
The initialization can be done by writing an arbitrary value to the time base timer clear control register (TBCLR).

## 8-4-2 Setup Example

### ■Timer Operation Setup (Time Base Timer)

An interrupt can be generated constantly with time base timer in the selected interrupt cycle. The interrupt generation cycle is as  $f_{osc} \times 1/2^{13}$  (as 0.977 ms :  $f_{osc} = 8.38$  MHz) for generation interrupts. An example setup procedure, with a description of each step is shown below.

Setup Procedure	Description
(1) Select the clock source. TM6MD (x'3F6A') bp0 : TM6CK0 = 0	(1) Select fosc as a clock source by the TM6CK0 flag of the timer 6 mode register (TM6MD).
(2) Select the interrupt generation cycle. TM6MD (x'3F6A') bp6-4 : TM6IR2-0 = 100	(2) Select the selected clock $\times 1/2^{13}$ as an interrupt generation cycle by the TM6IR2-0 flag of the TM6MD register.
(3) Initialize the time base timer. TBCLR (x'3F6B') = x'00'	(3) Write value to the time base timer clear control register (TBCLR) to initialize the time base timer. That makes the time base timer initialize.
(4) Set the interrupt level. TBICR (x'3FF0') bp7-6 : TBLV1-0 = 01	(4) Set the interrupt level by the TBLV1-0 flag of the time base interrupt control register (TBICR). If the interrupt request flag had already been set, clear it. [  Chapter 3 3-1-4. Interrupt Flag Setup ]
(5) Enable the interrupt. TBICR (x'3FF0') bp1 : TBIE = 1	(5) Set the TBIE flag of the TBICR register to "1" to enable the interrupt.

\* the above steps (1), (2) can be set at once.

When the selected interrupt generation cycle has passed, the interrupt request flag of the time base interrupt control register (TBICR) is set to "1".

## Chapter 9 Watchdog Timer

## 9-1 Overview

This LSI has a watchdog timer. This timer is used to detect software processing errors. It is controlled by the watchdog timer control register (WDCTR). And, once an overflow of watchdog timer is generated, a watchdog interrupt (WDIRQ) is generated. If the watchdog interrupt is generated twice, consecutively, it is regarded to be an indication that the software cannot execute in the intended sequence; thus, a system reset is initiated by the hardware.

### 9-1-1 Block Diagram

#### ■ Watchdog Timer Block Diagram

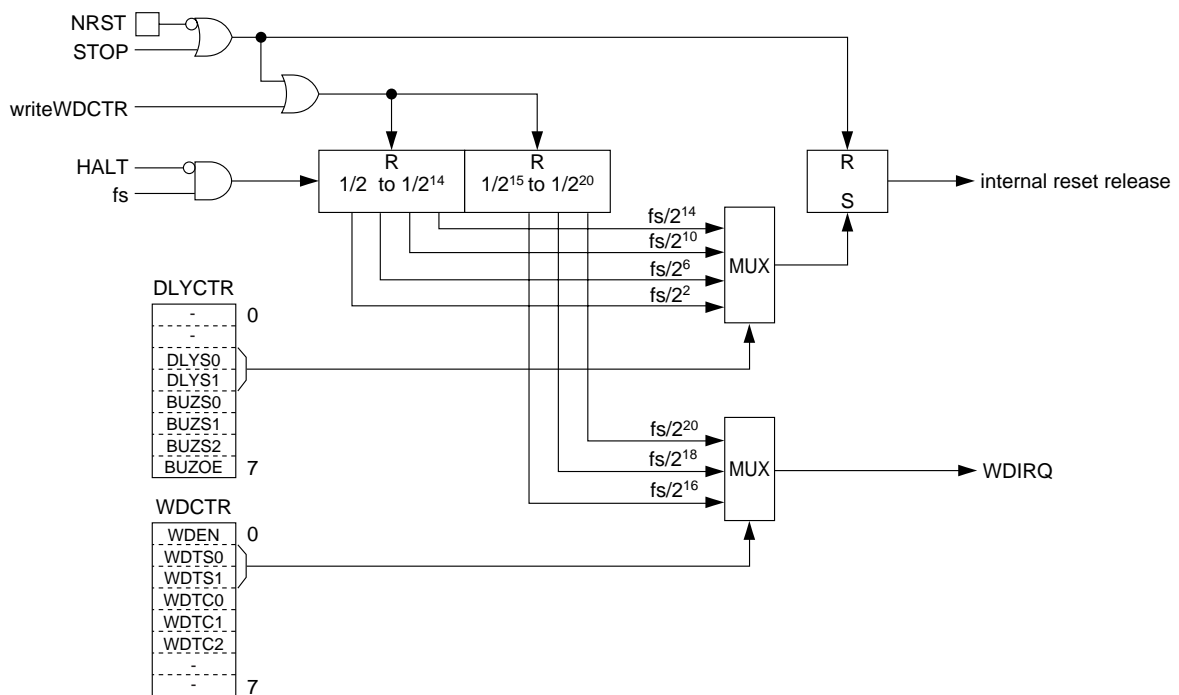



Figure 9-1-1 Block Diagram (Watchdog Timer)

The watchdog timer is also used as a timer to count the oscillation stabilization wait time. This is used as a watchdog timer except at recovering from STOP mode and at reset releasing.

The watchdog timer is initialized at reset or at STOP mode, and counts system clock (fs) as a clock source from the initial value (x'0000'). The oscillation stabilization wait time is set by the oscillation stabilization control register (DLYCTR). After the oscillation stabilization wait, counting is continued as a watchdog timer.

[  Chapter 2 2-8. Reset ]

## 9-2 Control Registers

The watchdog timer is controlled by the watchdog timer control register (WDCTR).

### ■ Watchdog Timer Control Register (WDCTR)

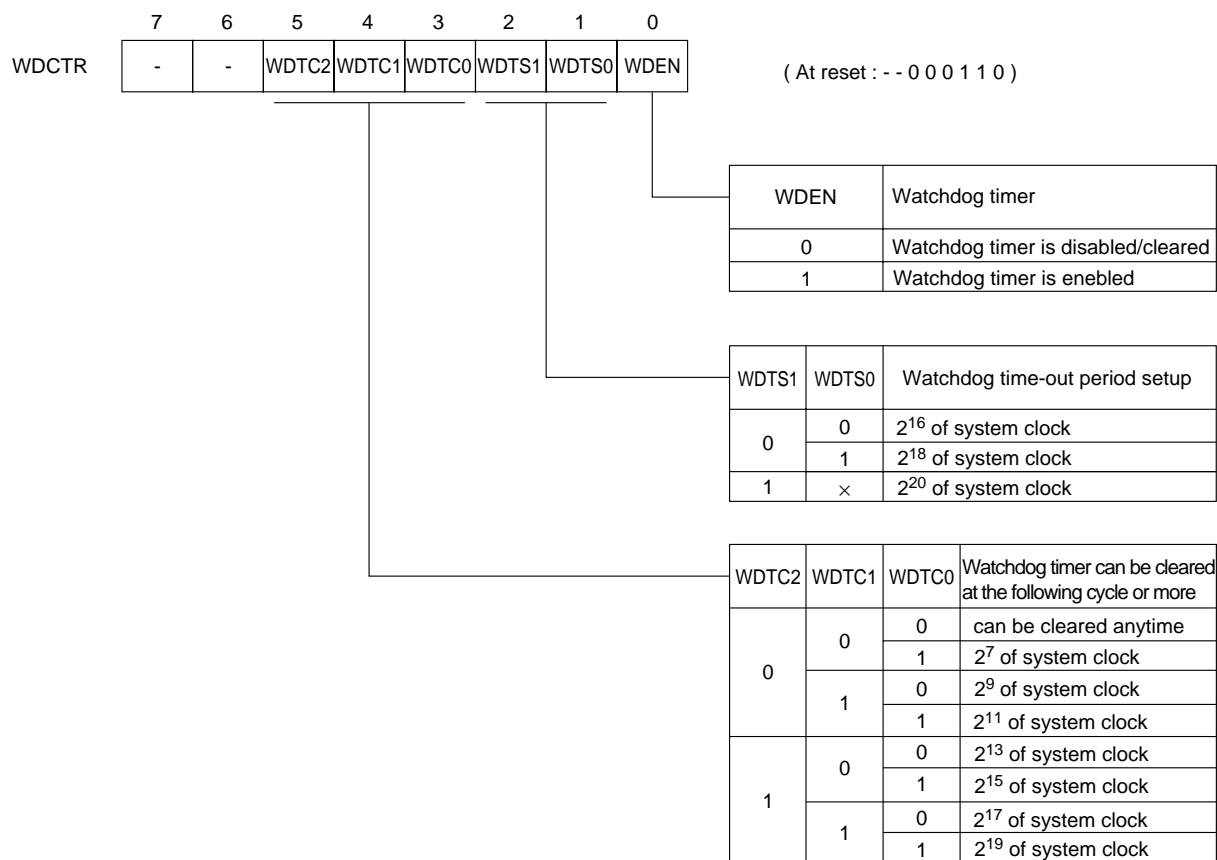


Figure 9-2-1 Watchdog Timer Control Register (WDCTR : x'03F02', R/W)

## 9-3 Operation

### 9-3-1 Operation

The watchdog timer counts system clock (fs) as a clock source. If the watchdog timer is overflows, the watchdog interrupt (WDIRQ) is generated as a non maskable interrupt (NMI). At reset, the watchdog timer is stopped, but once the operation is enabled, it cannot be stopped except at reset. The watchdog timer control register (WDCTR) sets when the watchdog timer is released or how long the time-out period should be.

This watchdog timer can detect such that the watchdog timer clear is repeated in short cycle. If the watchdog timer clear is repeated in shorter cycle than the set time (the lowest value of watchdog timer clear possible), it is regarded as an error and the watchdog interrupt (WDIRQ) is generated.

If the watchdog interrupt (WDIRQ) is generated twice consecutively, it is regarded to be an indication that the software cannot execute in the intended sequence; thus, a system reset is initiated by the hardware.



The watchdog timer cannot stop, once it starts operation.

#### ■Usage of Watchdog Timer

When the watchdog timer is used, constant clear in program is needed to prevent an overflow of the watchdog timer. As a result of the software failure, the software cannot execute in the intended sequence, thus the watchdog timer overflows and error is detected.



Programming of the watchdog timer is generally done in the last step of its programming.

#### ■How to Detect Incorrect Code Execution

The watchdog timer is executed to be cleared in the certain cycle on the correct code execution. On this LSI, the watchdog timer detects errors when,

- (1) the watchdog timer overflows.
- (2) the watchdog timer clear happens in the shorter cycle than the watchdog timer clear possible lowest value, set in the watchdog timer control register (WDCTR).

When the watchdog timer detects any error, the watchdog interrupt (WDIRQ) is generated as a non maskable interrupt (NMI).



### ■How to Clear Watchdog Timer

The watchdog timer can be cleared by writing to the watchdog timer control register (WDCTR). The watchdog timer can be cleared regardless of the writing data to the register. The bit-set (BSET) that does not change the value is recommended.


### ■Watchdog Timer Period

The watchdog timer period is decided by the bp2, 1 (WDTS1-0) of the watchdog timer control register (WDCTR) and the system clock (fs). If the watchdog timer is not cleared till the set period of watchdog timer, that is regarded as an error and the watchdog interrupt (WDIRQ) of the non-maskable interrupt (NMI) is generated.

**Table 9-3-1 Watchdog Timer Period**

WDTS1	WDTS0	Watchdog time-out period
0	0	$2^{16}$ X system clock
0	1	$2^{18}$ X system clock
1	X	$2^{20}$ X system clock

System clock is decided by the CPU mode control register (CPUM).

[  Chapter 2 2-5. Clock Switching ]

The watchdog timer period is generally decided from the execution time for main routine of program. That should be set the longer period than the value of the execution time for main routine divided by natural number (1, 2, , , ). And insert the instruction of the watchdog timer clear to the main routine as that value makes the same cycle.

### ■The Lowest Value for Watchdog Timer Clear

The lowest value for watchdog timer clear is decided by the bp5, 4, 3 (WDTC2, WDTC1, WDTC0) of the watchdog timer control register (WDCTR).

**Table 9-3-2 The Lowest Value for Watchdog Timer Clear**

WDTC2	WDTC1	WDTC0	Watchdog timer can be cleared at the following cycle or more
0	0	0	no limit
0	0	1	$2^7$ X system clock
0	1	0	$2^9$ X system clock
0	1	1	$2^{11}$ X system clock
1	0	0	$2^{13}$ X system clock
1	0	1	$2^{15}$ X system clock
1	1	0	$2^{17}$ X system clock
1	1	1	$2^{19}$ X system clock

■ Watchdog Timer and CPU Mode

The relation between this watchdog timer and CPU mode features are as follows ;

- (1) In NORMAL, IDLE, SLOW mode, the system clock is counted.
- (2) The counting is continued regardless of switching at NORMAL, IDLE, SLOW mode.
- (3) In HALT mode, the watchdog timer is stopped.
- (4) In STOP mode, the watchdog timer is cleared automatically by hardware.
- (5) In STOP mode, the watchdog interrupt cannot be generated.
- (6) After releasing reset or recovering from STOP, the counting is executed for the duration of the oscillation stabilization wait time.

Generally, in the system used STOP mode, if the STOP mode is done or not is divided on the program execution, but, in this case, the counting value of the watchdog timer differs. So, the watchdog interrupt should be prevented by setting the lowest value for watchdog timer clear.

## 9-3-2 Setup Example

The watchdog timer detects errors. On the following example, the watchdog timer period is set to  $2^{18} \times$  system clock, the lowest value for watchdog timer clear is set to  $2^9 \times$  system clock.

An example setup procedure, with a description of each step is shown below.

### ■Initial Setup Program (Watchdog Timer Initial Setup Example)

Setup Procedure	Description
(1) Set the time-out period. WDCTR (x'03F02') bp2-1 : WDTS1-0 = 01	(1) Set the WDTS1-0 flag of the watchdog timer control register (WDCTR) to "01" to select the time-out period to $2^{18} \times$ system clock.
(2) Set the lowest value for clear. WDCTR (x'03F02') bp5-3 : WDTC2-0 = 010	(2) Set the WDTC2-0 flag of the WDCTR register to "010" to select the lowest value for clear to $2^9 \times$ system clock.
(3) Start the watchdog timer operation. WDCTR (x'03F02') bp0 : WDEN = 1	(3) Set the WDEN flag of the WDCTR register to start the watchdog timer operation.




The command of setting the WDEN flag to "1" should be done on the last step of the initial setting. If the watchdog control register (WDCTR) is changed after starting the operation, the watchdog interrupt may be generated depending on the setting of the lowest value for clear.

### ■Main Routine Program (Watchdog Timer Constant Clear Setup Example)

Setup Procedure	Description
(1) Set the constant watchdog timer clear. Writing to WDCTR (x'03F02') (cf.) BSET (WDCTR) WDEN (bp0 : WDEN = 1)	(1) Clear the watchdog timer by the cycle from $2^9 \times$ system clock up to $2^{18} \times$ system clock.  The watchdog timer clear should be inserted in the main routine, with the same cycle, and to be the set cycle.  The recommended instruction is the bit-set (BSET), does not change value, for clear.

■Interrupt Service Routine Setup

Setup Procedure	Description
<p>(1) Set the watchdog interrupt service routine.</p> <p>NMICR (x'03FE1')</p> <p>TBNZ (NMICR) WDIR, WDPRO</p> <p>.....</p> <p>.....</p> <p>.....</p>	<p>(1) If the watchdog timer overflows, the non maskable interrupt is generated.</p> <p>Confirm that the WDIR flag of the non maskable interrupt control register (NMICR) is "1" on the interrupt service routine, and manage the suitable execution.</p>



The operation, just before the WDOG interrupt may be executed wrongly. Therefore, if the WDOG interrupt is generated, initialize the system.

## Chapter 10 Buzzer

## 10-1 Overview

This LSI has a buzzer. It can output the square wave, having a frequency  $1/2^9$  to  $1/2^{14}$  of the high speed oscillation clock, or by  $1/2^3$  to  $1/2^4$  of the low speed oscillation clock.

### 10-1-1 Block Diagram

■ Buzzer Block Diagram

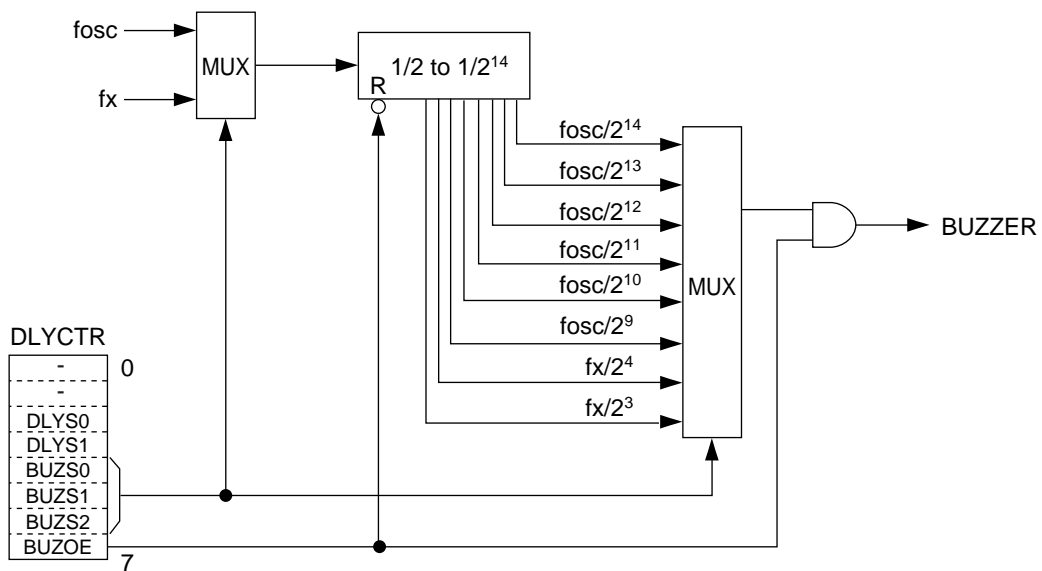
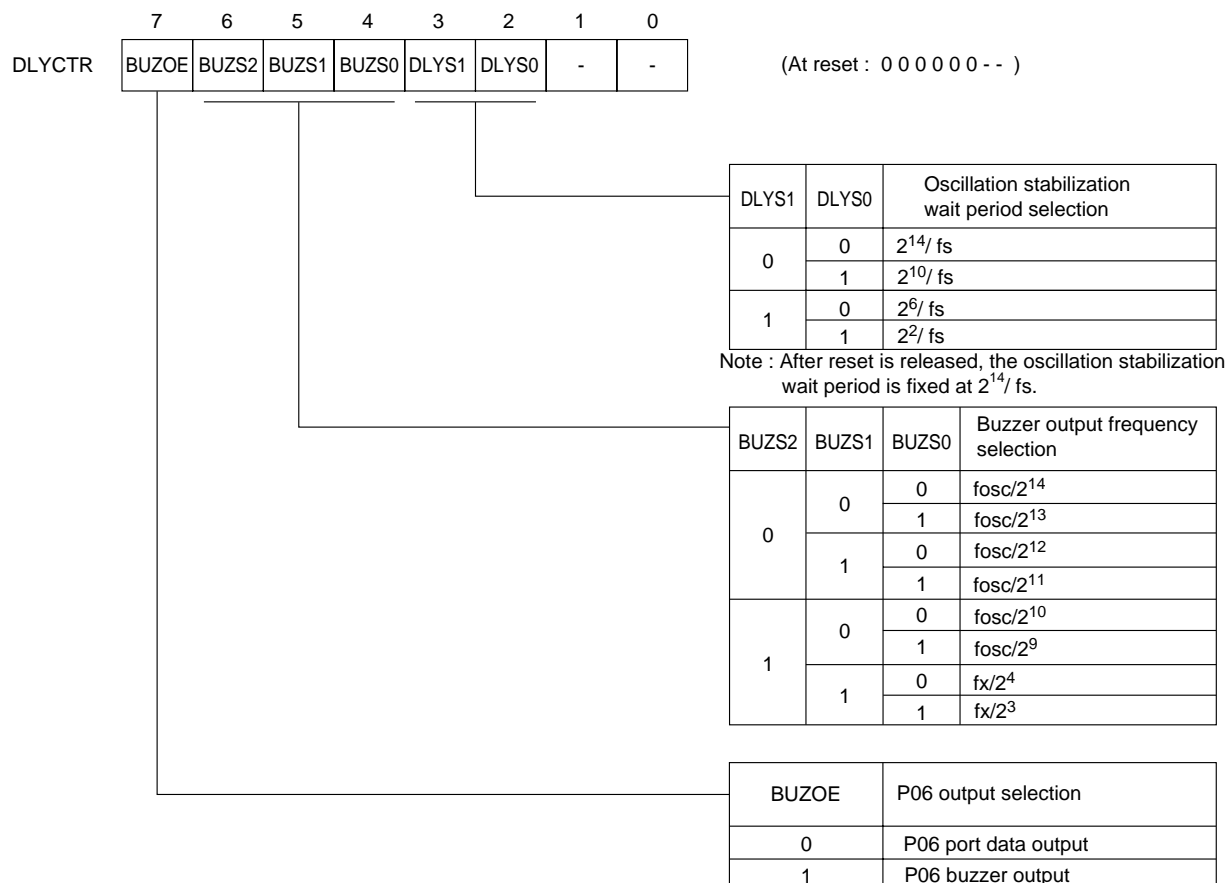


Figure 10-1-1 Block Diagram (Buzzer)

## 10-2 Control Register

### ■ Oscillation Stabilization Wait Timer Control Register



**Figure 10-2-1 Oscillation Stabilization Wait Time Control Register**  
(DLYCTR : x'03F03', R/W)

## 10-3 Operation

### 10-3-1 Operation

#### ■Buzzer

Buzzer outputs the square wave, having a frequency  $1/2^9$  to  $1/2^{14}$  of the high speed oscillation clock (fosc), or by  $1/2^3$  to  $1/2^4$  of the low speed oscillation clock (fx). The BUZS 2, 1, 0 flag of the oscillation stabilization wait control register (DLYCTR) set the frequency of buzzer output. The BUZOE flag of the oscillation stabilization wait control register (DLYCTR) sets buzzer output ON / OFF.

#### ■Buzzer Output Frequency

The frequency of buzzer output is decided by the frequency of the high oscillation clock (fosc) or the low oscillation clock (fx) and the bit 6, 5, 4 (BUZS2, BUZS1, BUZS0) of the oscillation stabilization wait control register (DLYCTR).

**Table 10-3-1 Buzzer Output Frequency**

fosc	fx	BUZS2	BUZS1	BUZS0	Buzzer output frequency
20 MHz	-	0	0	0	1.22 kHz
20 MHz	-	0	0	1	2.44 kHz
20 MHz	-	0	1	0	4.88 kHz
8.38 MHz	-	0	1	0	2.05 kHz
8.38 MHz	-	0	1	1	4.09 kHz
2 MHz	-	1	0	0	1.95 kHz
2 MHz	-	1	0	1	3.91 kHz
-	32 kHz	1	1	0	2 kHz
-	32 kHz	1	1	1	4 kHz



## 10-3-2 Setup Example

Buzzer outputs the square wave of 2 kHz from P06 pin. It is used 8.38 MHz as the high oscillation clock (fosc).

An example setup procedure, with a description of each step is shown below.

Setup Procedure	Description
(1) Set the buzzer frequency. DLYCTR (x'3F03') bp6-4 : BUZS2-0 = 010	(1) Set the BUZS2-0 flag of the oscillation stabilization wait control register (DLYCTR) to "010" to select fosc/2 <sup>12</sup> to the buzzer frequency. When the high oscillation clock fosc is 8.38 MHz, the buzzer output frequency is 2.05 kHz.
(2) Set P06 pin. P0OUT (x'3F10') bp6 : P0OUT6 = 0 P0DIR (x'3F30') bp6 : P0DIR6 = 1	(2) Set the output data P0OUT6 of P06 pin to "0", and set the direction control P0DIR6 of P06 pin to "1" to select output mode. Port 06 pin outputs low level.
(3) Buzzer output ON. DLYCTR (x'3F03') bp7 : BUZOE = 1	(3) Set the BUZOE flag of the oscillation stabilization wait control register (DLYCTR) to "1" to output the square wave of the buzzer output frequency set by P06 pin.
(4) Buzzer output OFF. DLYCTR (x'3F03') bp7 : BUZOE = 0	(4) Set the BUZOE flag of the oscillation stabilization wait control register (DLYCTR) to "0" to clear, and P06 pin outputs low level.






# 11-1 Overview

This LSI contains a serial interface 0 that can be used for both communication types of clock synchronous and UART (duplex).

## 11-1-1 Functions

Table 11-1-1 shows functions of serial interface 0.

**Table 11-1-1 Serial Interface 0 Functions**

Communication style	clock synchronous	UART (duplex)
Interrupt	SC0TIRQ	SC0TIRQ (on transmission completion) SC0RIRQ (on reception completion)
Used pins	SBO0,SBI0,SBT0	TXD0,RXD0
3 channels type	√	-
2 channels type	√ (SBO0, SBT0)	√
1 channel type	-	√ (TXD0)
Specification of transfer bit count / Frame selection	1 to 8 bits	7 bits + 1stop 7 bits + 2stops 8 bits + 1stop 8 bits + 2stops
Selection of parity bit	-	√
Parity bit control	-	0 parity 1 parity odd parity even parity
Selection of start condition	√	only "enable start condition" is available
Specification of the first transfer bit	√	√
Specification of input edge / output edge	√	-
Continuous operation	√	√
Continuous operation (with ATC1)	√	√
Internal clock 1/8 dividing	√	only 1/8 dividing is available
Clock source	fosc/2 fosc/4 fosc/16 fosc/64 fs/2 fs/4 Timer 2 output Timer 4 output External clock	fosc/2 fosc/4 fosc/16 fosc/64 fs/2 fs/4 Timer 2 output Timer 4 output
Maximum transfer rate	2.5 MHz	300 kbps (standard 300 bps to 38.4 kbps) (timer 4 output)
fosc : Machine clock (High speed oscillation) fs : System clock [  Chapter 2 2-5. Clock Switching ]		

## 11-1-2 Block Diagram

### Serial Interface 0 Block Diagram

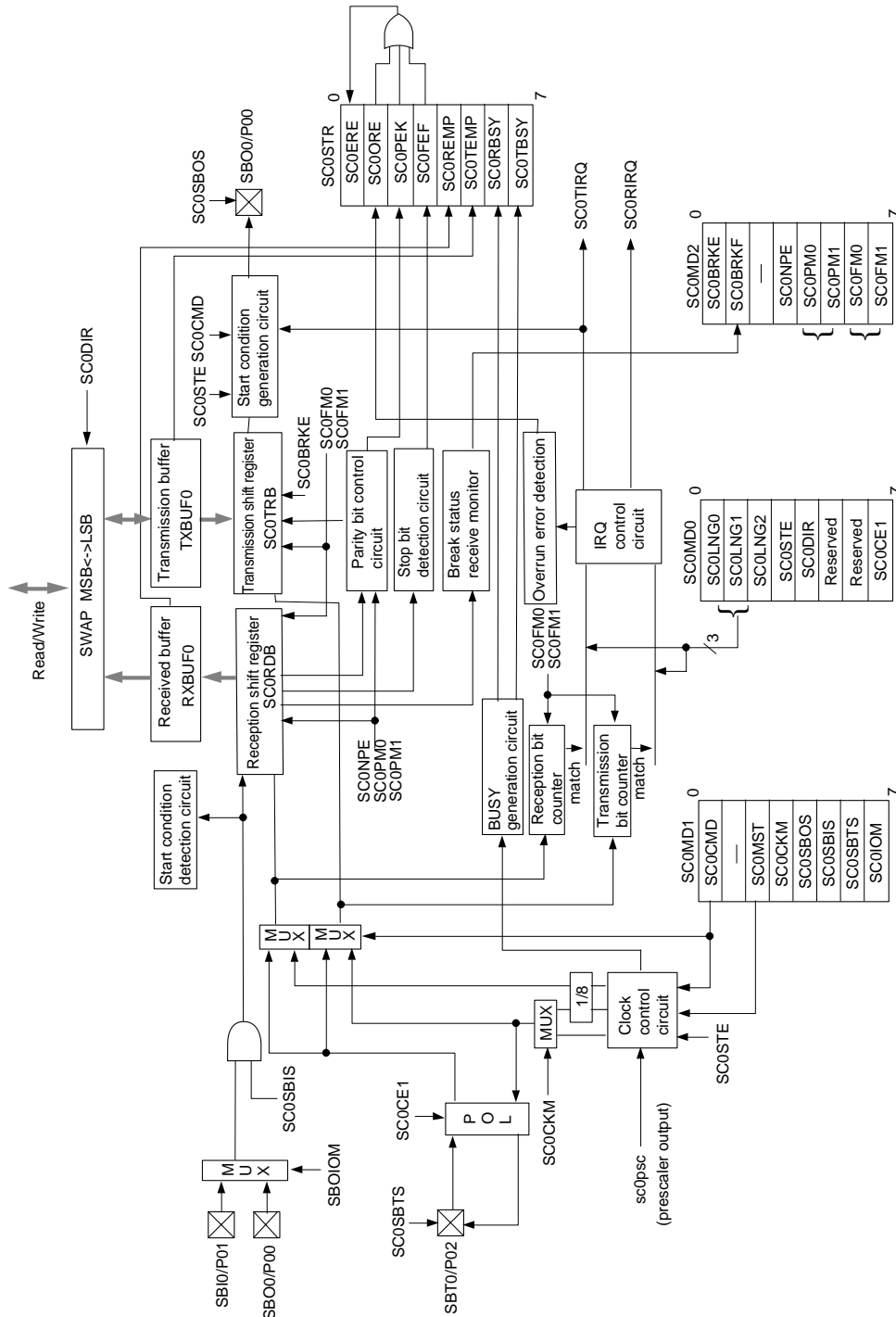


Figure 11-1-1 Serial Interface 0 Block Diagram

## 11-2 Control Registers

### 11-2-1 Registers

Table 11-2-1 shows registers to control serial interface 0.

**Table 11-2-1 Serial Interface 0 Control Registers**

	Register	Address	R/W	Function	Page
Serial interface 0	SC0MD0	x'03F90'	R/W	Serial interface 0 mode register 0	XI - 6
	SC0MD1	x'03F91'	R/W	Serial interface 0 mode register 1	XI - 7
	SC0MD2	x'03F92'	R/W	Serial interface 0 mode register 2	XI - 8
	SC0STR	x'03F93'	R	Serial interface 0 state register	XI - 9
	RXBUF0	x'03F94'	R	Serial interface 0 reception data buffer	XI - 5
	TXBUF0	x'03F95'	R/W	Serial interface 0 transmission data buffer	XI - 5
	SC0ODC	x'03F96'	R/W	Serial interface 0 port control register	XI - 10
	SC0CKS	x'03F97'	R/W	Serial interface 0 transfer clock selection register	XI - 11
	PSCMD	x'03F6F'	R/W	Prescaler control register	V - 6
	P0DIR	x'03F30'	R/W	Port 0 direction control register	IV - 8
	P0PLU	x'03F40'	R/W	Port 0 pull-up control register	IV - 8
	SC0RICR	x'03FF5'	R/W	Serial interface 0 UART reception interrupt control register	III - 33
	SC0TICR	x'03FF6'	R/W	Serial interface 0 interrupt control register	III - 34

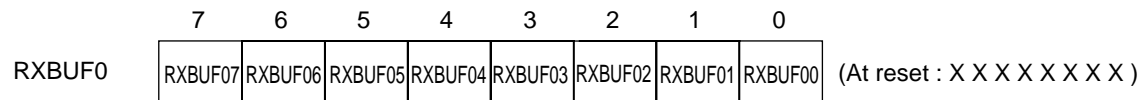
R/W : Readable / Writable

R : Readable only

## 11-2-2 Data Buffer Registers

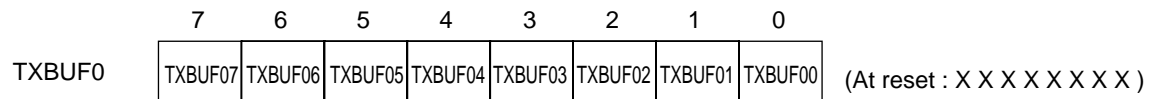
Serial Interface 0 has each 8-bit data buffer register for transmission, and for reception.

### ■Serial Interface 0 Reception Data Buffer (RXBUF0)



**Figure 11-2-1 Serial Interface 0 Reception Data Buffer (RXBUF0 : x'03F94', R)**

### ■Serial Interface 0 Transmissin Data Buffer (TXBUF0)



**Figure 11-2-2 Serial Interface 0 Transmission Data Buffer (TXBUF0 : x'03F95', R/W)**

### 11-2-3 Mode Registers

#### Serial Interface 0 Mode Register 0 (SC0MD0)

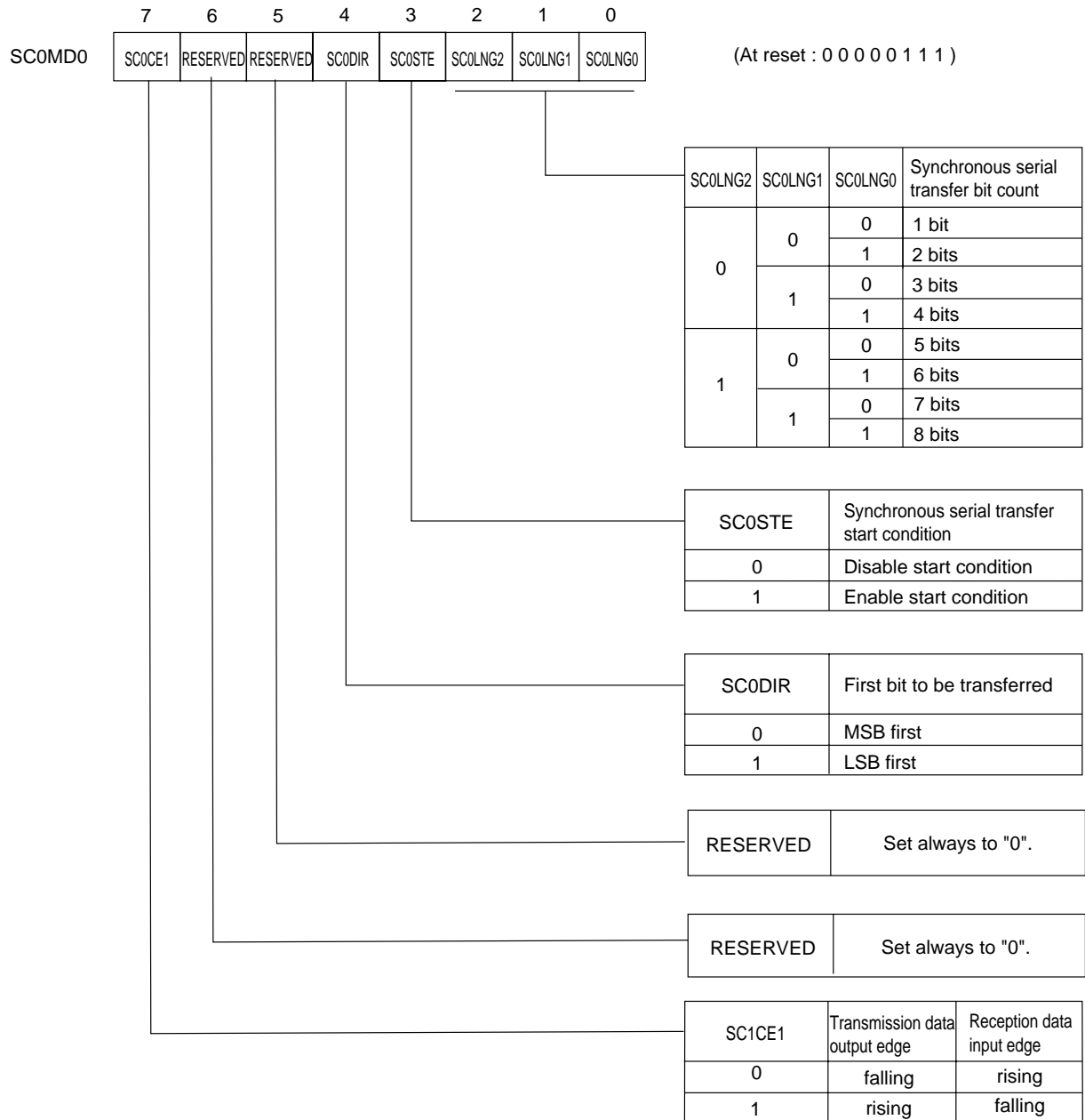


Figure 11-2-3 Serial Interface 0 Mode Register 0 (SC0MD0 : x'03F90', R/W)



■Serial Interface 0 Mode Register 1 (SC0MD1)

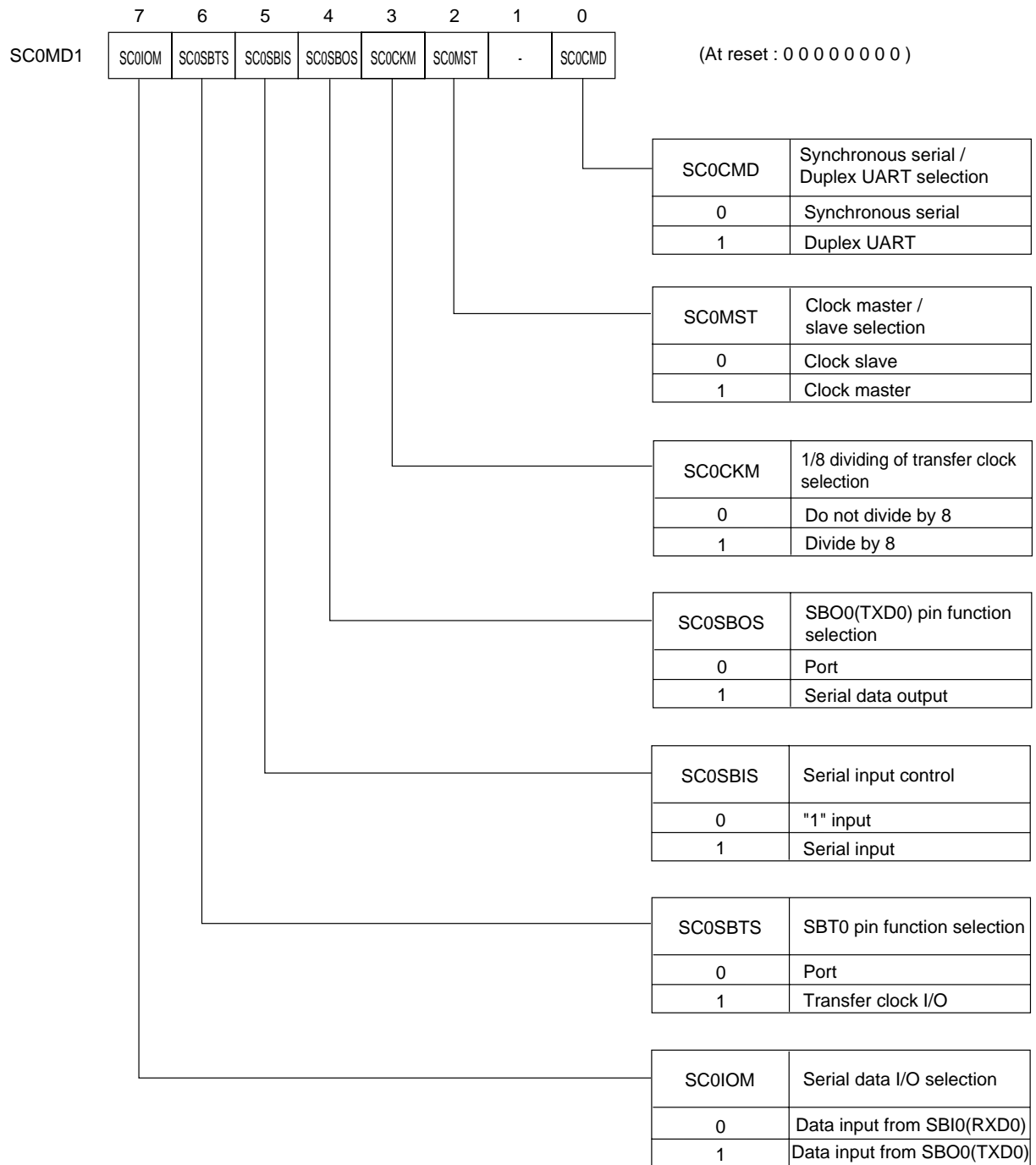


Figure 11-2-4 Serial Interface 0 Mode Register 1 (SC0MD1 : x'03F91', R/W)

■Serial Interface 0 Mode Register 2 (SC0MD2)

SC0BRKF flag is only for reading.

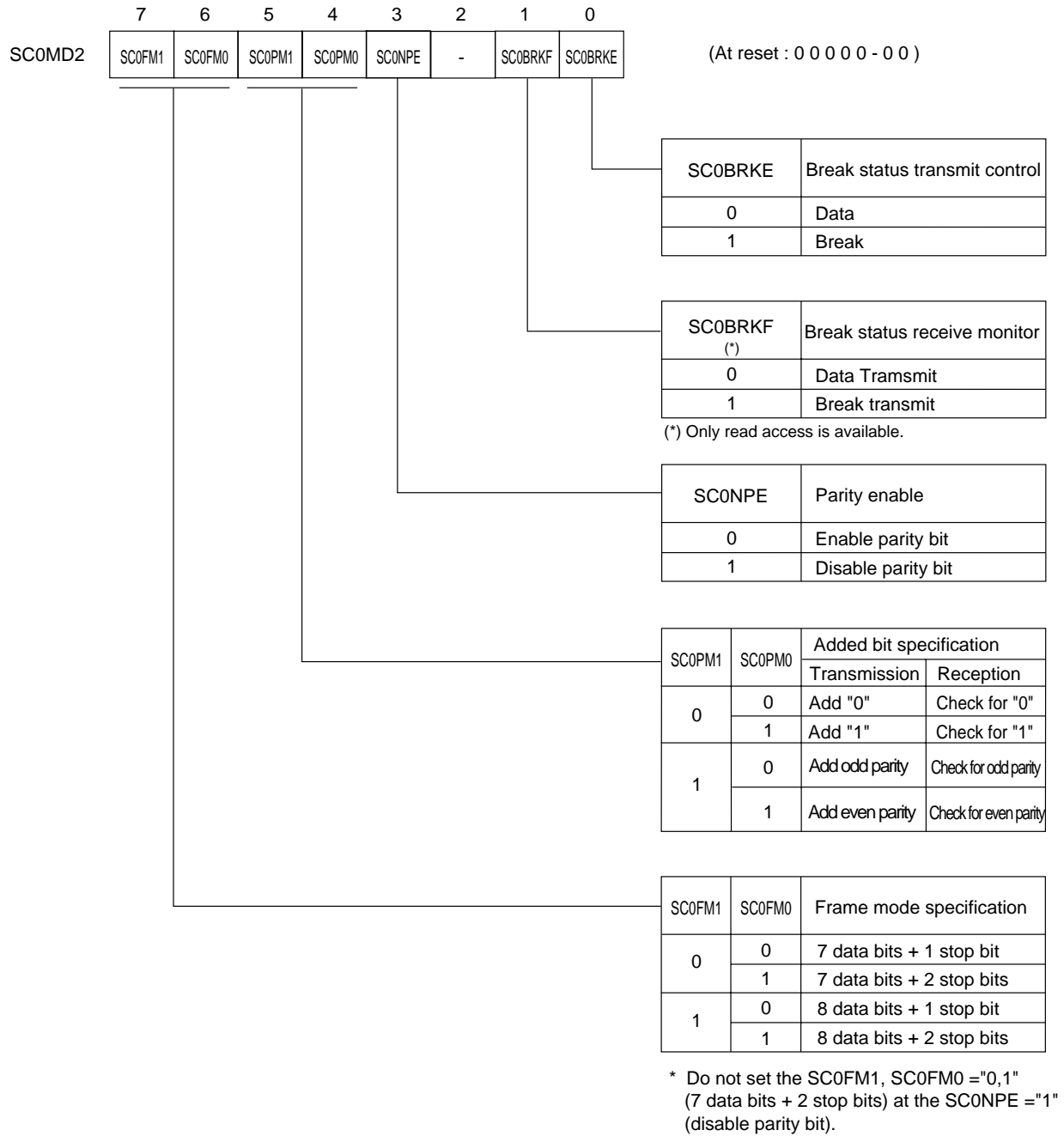


Figure 11-2-5 Serial Interface 0 Mode Register 2 (SC0MD2 : x'03F92', R/W)

■Serial Interface 0 State Register (SC0STR)

All flags are only for reading.

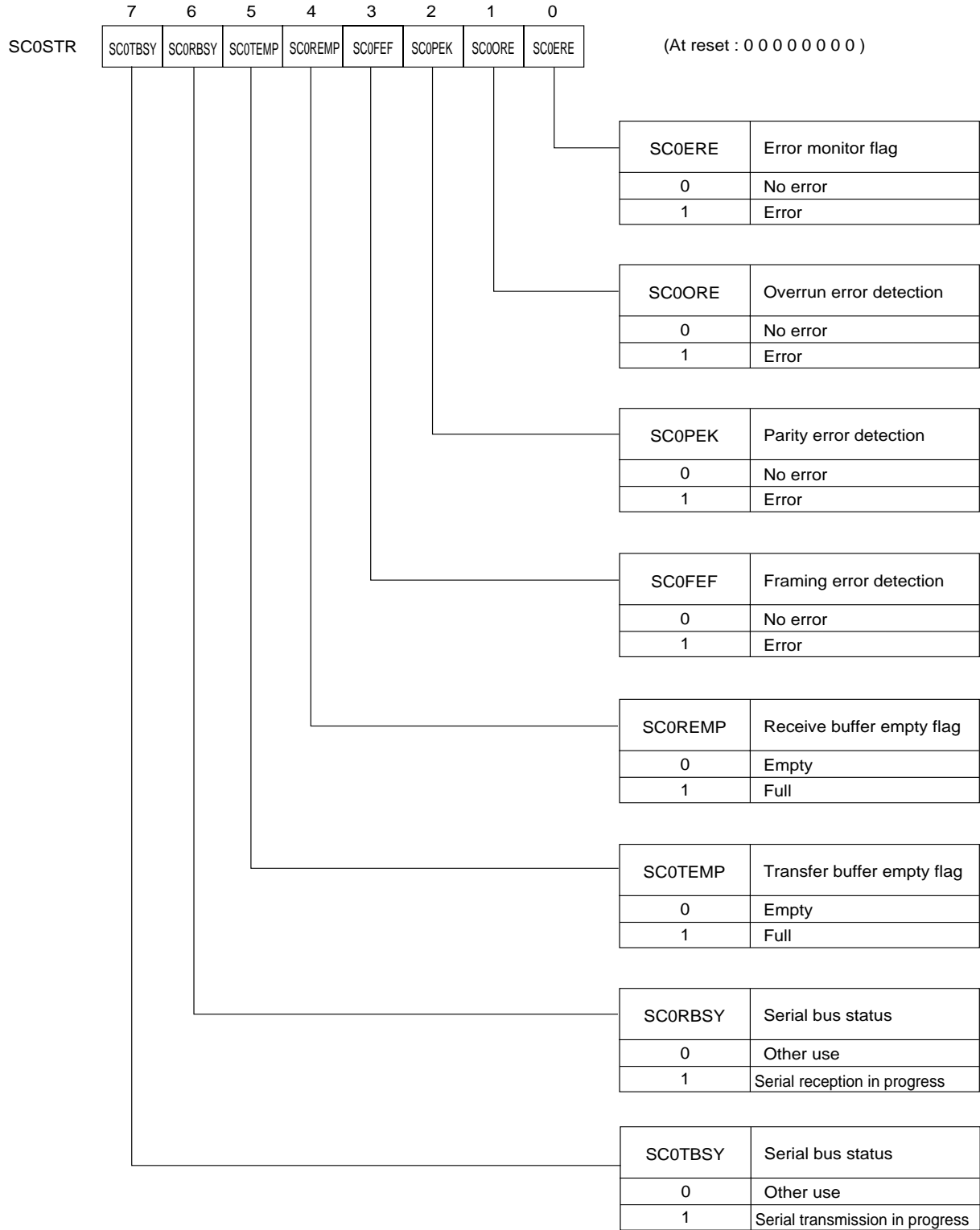


Figure 11-2-6 Serial Interface 0 State Register (SC0STR : x'03F93', R)

■Serial Interface 0 Port Control Register (SC0ODC)

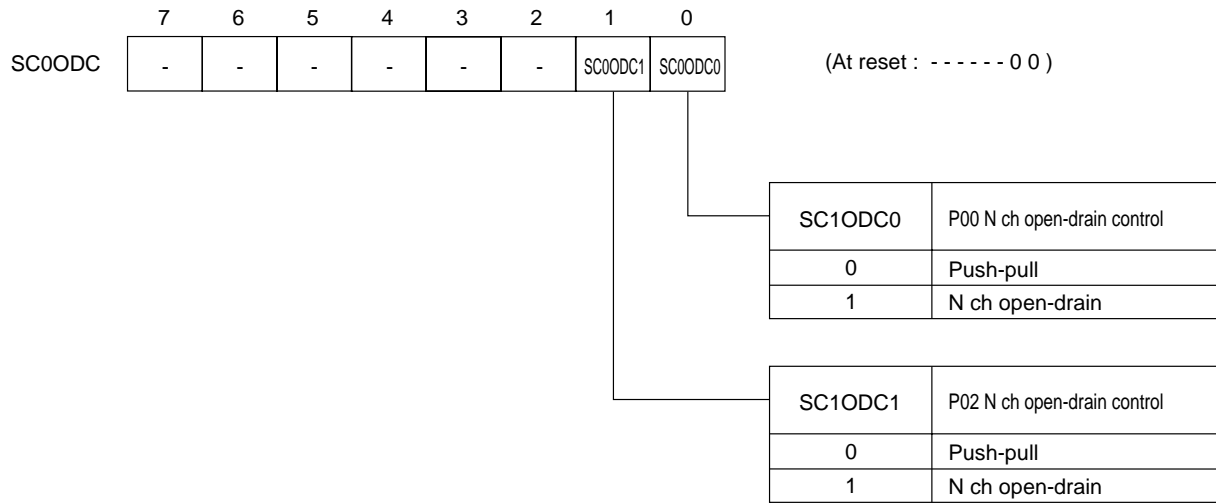


Figure 11-2-7 Serial Interface 0 Port Control Register (SC0ODC : x'03F96', R/W)

■ Serial Interface 0 Transfer Clock Selection Register (SC0CKS)

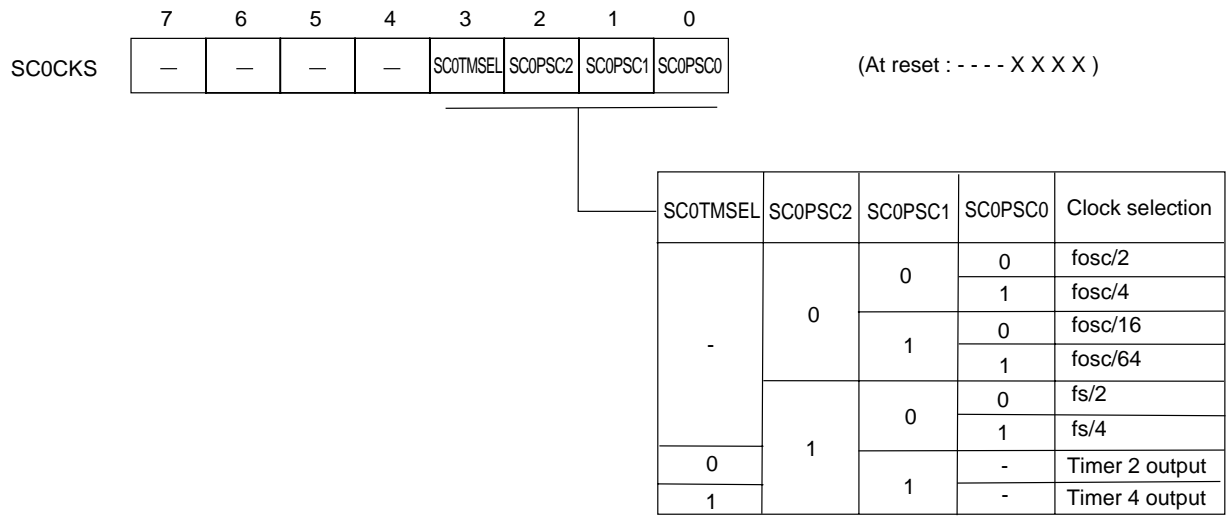


Figure 11-2-8 Serial Interface 0 Transfer Clock Selection Register (SC0CKS : x'03F97', R/W)

When timer output is selected as serial interface transfer clock, select fosc as a clock source of the timer. If other clock is selected, normal transfer of serial interface data is not guaranteed.

## 11-3 Operation

Serial Interface 0 can be used for both clock synchronous and duplex UART.

### 11-3-1 Clock Synchronous Serial Interface

■Activation Factor for Communication


Table 11-3-1 shows activation factors for communication. At master, the transfer clock is generated by setting data to the transmission data buffer TXBUF0, or by receiving a start condition. Except during communication, the input signal from SBT0 pin is masked to prevent errors by noise or so. This mask can be released automatically by setting a data to TXBUF0(access to the TXBUF0 register), or by inputting a start condition to the data input pin. Therefore, at slave, set data to TXBUF0, or input an external clock after a start condition is input.

**Table 11-3-1 Synchronous Serial Interface Activation Factor**

	Activation factor	
	Transmission	Reception
at master	Set transmission data	Set dummy data
		Input start condition
at slave	Input clock after transmission data is set	Input clock after dummy data is set
		Input clock after start condition is input

■Transfer Bit Setup

The transfer bit count is selected from 1 bit to 8 bits. Set them by the SC0LNG 2 to 0 flag of the SC0MD0 register (at reset : 111). The SC0LNG 2 to 0 flag holds the former set value until it is set again.



Except during communication, SBT0 pin is masked to prevent errors by noise. At slave communication, set data to TXBUF0 or input a clock to SBT0 pin after a start condition is input.

### ■Start Condition Setup

The SC0STE flag of the SC0MD0 register sets if a start condition is enabled or not. If a start condition is enabled, and received at communication, a bit counter is cleared to restart the communication. The start condition, if the SC0CE1 flag of the SC0MD0 register is set to "0", is regarded when a data line (SBI0 pin (with 3 channels) or SBO0 pin (with 2 channels) is changed from "H" to "L" as a clock line (SBT0 pin) is "H". Also, the start condition, if the SC0CE1 flag of the SC0MD0 register is set to "1", is regarded when a data line (SBI0 pin (with 3 channels) or SBO0 pin (with 2 channels) is changed from "H" to "L" as a clock line (SBT0 pin) is "L". Both the SC0SBOS flag and the SC0SBIS flag of the SC0MD1 register should be set to "0", before the start condition setup is changed

### ■First Transfer Bit Setup

The SC0DIR flag of the SC0MD0 register can set the first transfer bit. MSB first or LSB first can be selected.

### ■Transmission Data Buffer

The transmission data buffer, TXBUF0 is the sub buffer that stores data to load the internal shift register. Data to be transferred should be set to the transmission data buffer, TXBUF0 to load to the internal shift register automatically. The first data loading to the internal shift register is done at the same timing of the data setting to TXBUF0.

### ■Received Data Buffer

The received data buffer RXBUF0 is the sub buffer that pushed the received data in the internal shift register. After the communication complete interrupt SC0IRQ is generated, data stored in the internal shift register is stored to the received data buffer RXBUF0 automatically. RXBUF0 can store data up to 1 byte. RXBUF0 is rewritten in every communication complete, so read out data of RXBUF0 till the next receive complete. The received data buffer empty flag SC0REMP is set to "1" at the same time SC0TIRQ is generated. SC0REMP is cleared to "0" after RXBUF0 is read.



If a start condition is input to restart during communication, the transmission data is not valid. If the transmission should be operated again, set the transmission data to TXBUF0, again.



Start condition should be switched after both the SC0SBOS and the SC0SBIS flags of the SC0MD1 register are set to "0". If they are not set to "0", the switching is not valid.



RXBUF0 is rewritten in every communication complete. At continuous communication, data of RXBUF0 should be read out till the next reception complete.

■Transfer Bit Count and First Transfer Bit

When the transfer bit is 1 bit to 7 bits, the data storing method to the transmission data buffer TXBUF0 is different, depending on the first transfer bit selection. At MSB first, use the upper bits of TXBUF0 for storing. When there are 6 bits to be transferred, as shown on figure 11-3-1, if data "A" to "F" are stored to bp2 to bp7 of TXBUF0, the transmission is operated from "F" to "A". At LSB first, use the lower bits of TXBUF0 for storing. When there are 6 bits to be transferred, as shown on figure 11-3-2, if data "A" to "F" are stored to bp0 to bp5 of TXBUF0, the transmission is operated from "A" to "F".

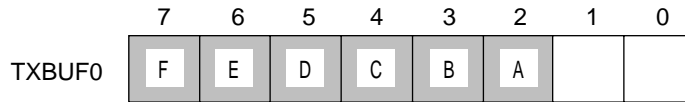


Figure 11-3-1 Transfer Bit Count and First Transfer Bit (starting with MSB)

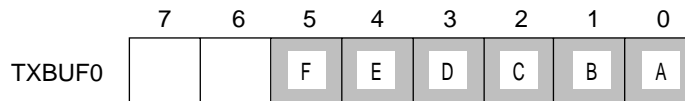


Figure 11-3-2 Transfer Bit Count and First Transfer Bit (starting with LSB)

■Receive Bit Count and First Transfer Bit

When the transfer bit count is 1 bit to 7 bits, the data storing method to the received data buffer RXBUF0 is different depending on the first transfer bit selection. At MSB first, data are stored to the lower bits of RXBUF0. When there are 6 bits to be transferred, as shown on figure 11-3-3, if data "F" to "A" are stored to bp0 to bp5 of RXBUF0. At LSB first, data are stored to the upper bits of RXBUF0. When there are 6 bits to be transferred, as shown on figure 11-3-4, if data "A" to "F" are stored to bp2 to bp7 of RXBUF0.

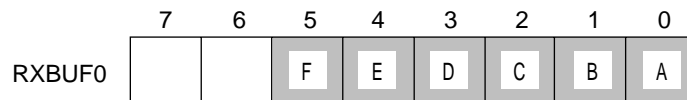


Figure 11-3-3 Receive Bit Count and Transfer First Bit (starting with MSB bit)

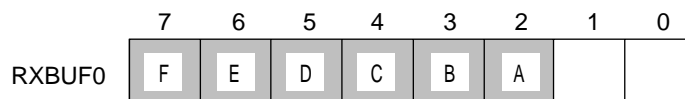


Figure 11-3-4 Receive Bit Count and Transfer First Bit (starting with LSB bit)



### ■Continuous Communication

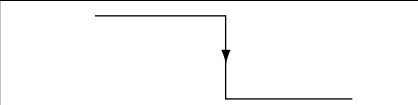
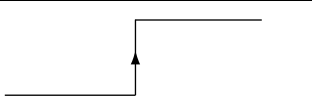
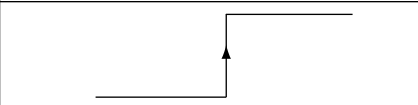
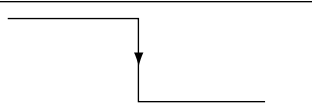
This serial has a function for continuous communication. If data is set to the transmission data buffer TXBUF0 during communication, the transmission buffer empty flag SC0TEMP is automatically set to communicate continuously. Data setup to TXBUF0 should be done till the communication complete interrupt SC0IRQ is generated after the former data is set. At master communication, there is a suspension of communication for 3 transfer clocks till the next transmission clock is output after the SC0IRQ generation.

Also, the built-in automatic data transfer function ATC can activate. Data can be transferred continuously up to 255 bytes by ATC activation. In this case, there is a suspension of communication for up to 18 machine cycles + 2.5 transfer clocks. Refer to the transfer mode 8 to 9 in chapter 15, automatic transfer controller for ATC activation.

### ■Input Edge / Output Edge Setup

The SC0CE 1 to 0 flag of the SC0MD0 register set an output edge of the transmission data, an input edge of the received data. As the SC0CE1 flag = "0", the transmission data is output at the falling edge, and as "1", output at the rising edge. As SC0CE1="0", the received data is received at the inversion edge to the output edge of transmission data, and as "1", stored at the same edge.

**Table 11-3-2 Transmission Data Output Edge and Received Data Input Edge**


SC0CE1	Transmission data output edge	Received data input edge
0		
1		

■Clock Setup

The SC0CKS register selects a clock source from the special prescaler and timer 4 output. The special prescaler starts its operation after the PSCMD (x'03F6F') register selects "prescaler operation". The SC0MST flag of the SC0MD1 register can select the internal clock (clock master), or the external clock (clock slave). Even if the external clock is selected, set the internal clock that has the same clock cycle or below to the external clock, by the SC0CKS register. That is happened, because the interrupt flag SC0TIRQ is generated by the internal clock. Here is the internal clock source that can be set by the SC0CKS register. Also, the SC0CKM flag of the SC0MD1 register can divide the internal clock by 8.


**Table 11-3-3 Synchronous Serial Interface Internal Clock Source**


Internal clock	fosc/2
	fosc/4
	fosc/16
	fosc/64
	fs/2
	fs/4
	Timer 2 output
	Timer 4 output

 When timer output is selected as serial interface transfer clock, select fosc as a clock source of the timer. If other clock is selected, normal transfer of serial interface data is not guaranteed.

■Data Input Pin Setup

3 channels type (clock pin (SBT0 pin), data output pin (SBO0 pin), data input pin (SBI0 pin)) or 2 channels type (clock pin (SBT0 pin), data I/O pin (SBO0 pin)) can be selected as the communication. SBI0 pin can be used for only serial data input. SBO0 pin can be used for serial data input or output. The SC0IOM flag of the SC0MD1 register can select if the serial data is input from SBI0 pin or SBO0 pin. When "data input from SBO0 pin" is selected to set the 2 channels type, the P0DIR0 flag of the P0DIR register controls direction of SBO0 pin to switch transmission / reception. At that time, SBI0 pin is free to be used as a general port.

 The transfer speed should be up to 2.5 MHz. If the transfer clock is over 2.5 MHz, the transmission data may not be sent correctly.

 At reception, if SC0IOM of the SC0MD1 register is set to "1" and "serial data input from SBO0" is selected, SBI0 pin is used as a general port.

#### ■Received Buffer Empty Flag

When the reception is completed (the last data reception edge of the clock is input), data is stored to RXBUF0 from the internal shift register, automatically. If data is stored to the shift register RXBUF0, the received buffer empty flag SC0REMP of the SC0STR register is set to "1". That indicates that the received data is going to be read. SC0REMP is cleared to "0" by reading out the data of RXBUF0.

#### ■Transmission Buffer Empty Flag

If any data is set to TXBUF0 again, during communication (after setting data to TXBUF0 before generating the communication complete interrupt SC0IRQ), the transmission buffer empty flag SC0TEMP of the SC0STR register is set to "1". That indicates that the next transmission data is going to load. Data is loaded to the inside shift register from TXBUF0 by generation of SC0TIRQ, and the next transfer is started as SC0TEMP is cleared to "0".

#### ■Overrun Error and Error Monitor Flag

If, after reception complete, the next data has been already received before reading out the data of the received data buffer RXBUF0, overrun error is generated and the SC0ORE flag of the SC0STR register is set to "1". And at the same time, the error monitor flag SC0ERE is set to indicate that something wrong on reception. The SC0ORE flag holds the status unless the data of RXBUF0 is read out. SC0ERE is cleared as SC0ORE flag is cleared. These error flags are nothing to do with communication operation.

#### ■Reception BUSY Flag

When any data is set to TXBUF0 or when the SC0SBIS flag of the SC0MD1 register is "1" as start condition is input, the SC0RBSY flag of the SC0STR register is set to "1". And, on the generation of the communication complete interrupt SC0TIRQ, the flag is cleared to "0". And, during continuous communication, the SC0RBSY flag is always set. If the transmission buffer empty flag SC0TEMP is cleared to "0" as the communication complete interrupt SC0TIRQ is generated, SC0RBSY is cleared to "0". If the SC0SBIS flag is set to "0" during communication, the SC0RBSY flag is cleared to "0".

#### ■Transmission BUSY Flag

When any data is set to TXBUF0 or when the SC0SBOS flag of the SC0MD1 register is "1" as start condition is input, the SC0TBSY flag of the SC0STR register is set to "1". And, on the generation of the communication complete interrupt SC0TIRQ, the flag is cleared to "0". And, during continuous communication, the SC0TBSY flag is always set. If the transmission buffer empty flag SC0TEMP is cleared to "0" as the communication complete interrupt SC0TIRQ is generated, SC0TBSY is cleared to "0". If the SC0SBOS flag is set to "0" during communication, the SC0TBSY flag is cleared to "0".

■Emergency Reset

It is possible to shut down communication. For a forced reset, the SC0SBOS flag and the SC0SBIOS flag of the SC0MD1 register should be set to "0" (SBO0 pin : port, input data : "1" input). At forced reset, the status registers (the SC0BRKF flag of the SC0MD2 register, all flags of the SC0STR register) are initialized as they are set at reset, but the control register holds the setting value.

■Last Bit of Transfer Data

Table 11-3-4 shows the data output holding period of the last bit at transmission, and the minimum data input period of the last bit at reception. After data output holding period of the last bit, "H" is output.

**Table 11-3-4 Last Bit Data Length of Transfer Data**

	The last bit data holding period at transmission	The last data input period at reception
At master	1 bit data length	1 bit data length (Minimum)
At slave	[1 bit data length of external clock x 1/2] + [Internal clock frequency x (1/2 to 1) ]	

■Other Control Flag Setup

Table 11-3-5 shows flags that are not used at clock synchronous communication. So, they are not needed to set or monitor.

**Table 11-3-5 Other Control Flag**

Register	Flag	Detail
SC0MD2	SC0BRKF	Brake status reception monitor
	SC0NPE	Parity is enabled
	SC0PM1 to 0	Added bit specification
	SC0FM1 to 0	Frame mode specification
SC0STR	SC0PEK	Parity error detection
	SC0FEF	Frame error detection

■Transmission Timing

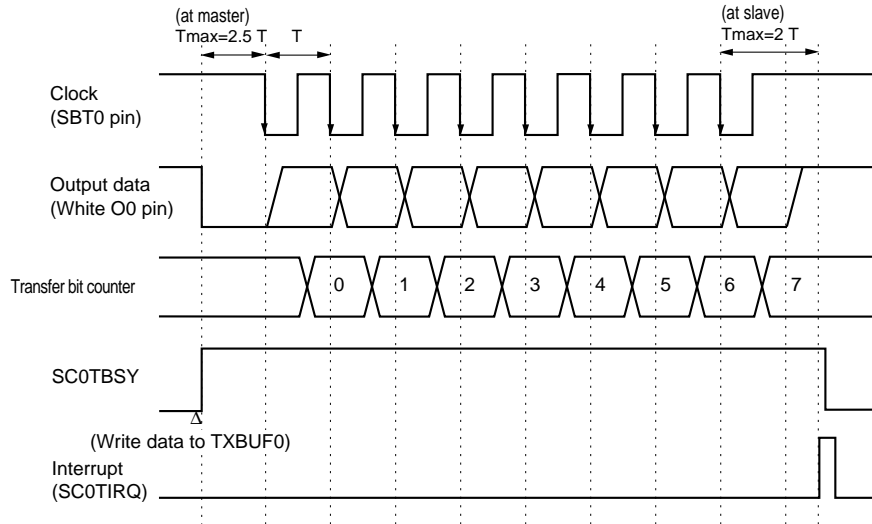


Figure 11-3-5 Transmission Timing (falling edge, start condition is enabled)

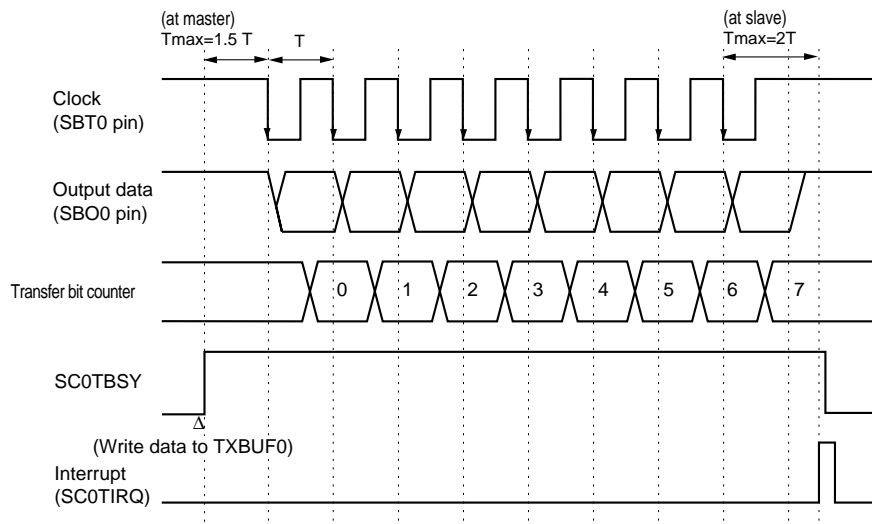
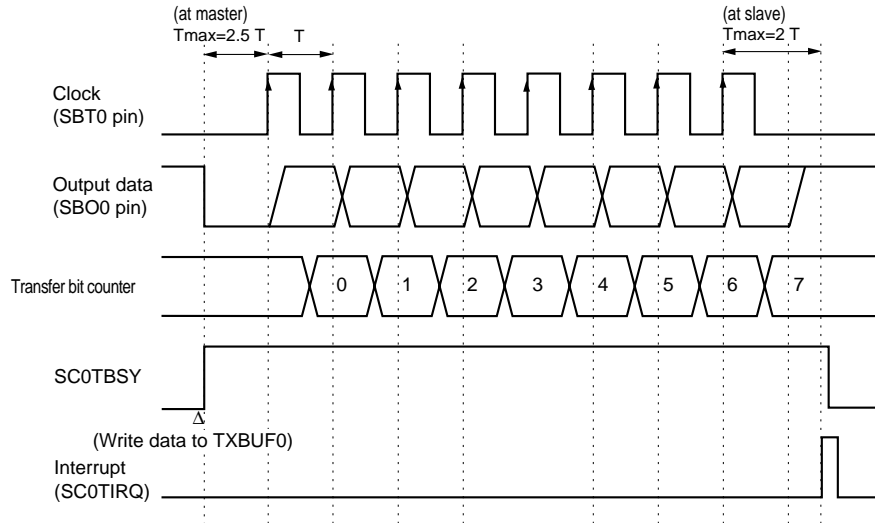
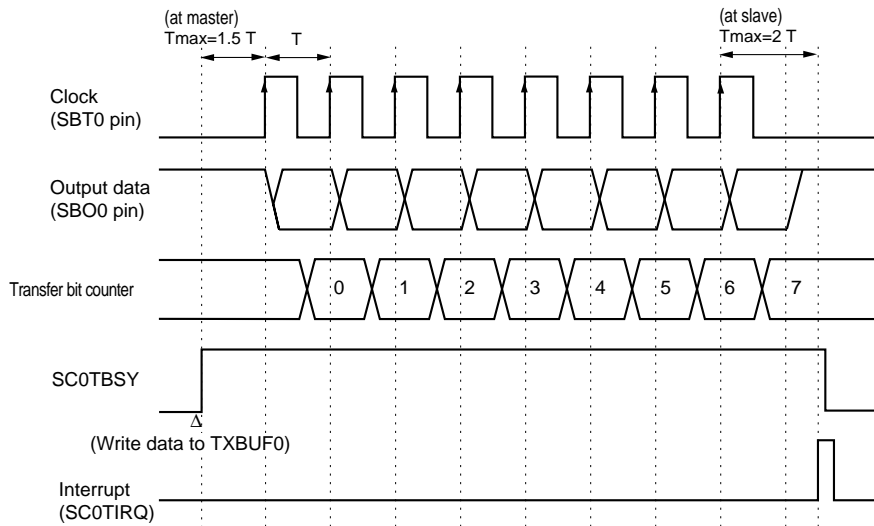


Figure 11-3-6 Transmission Timing (falling edge, start condition is disabled)



**Figure 11-3-7 Transmission Timing (rising edge, start condition is enabled)**



**Figure 11-3-8 Transmission Timing (rising edge, start condition is disabled)**

■ Reception Timing

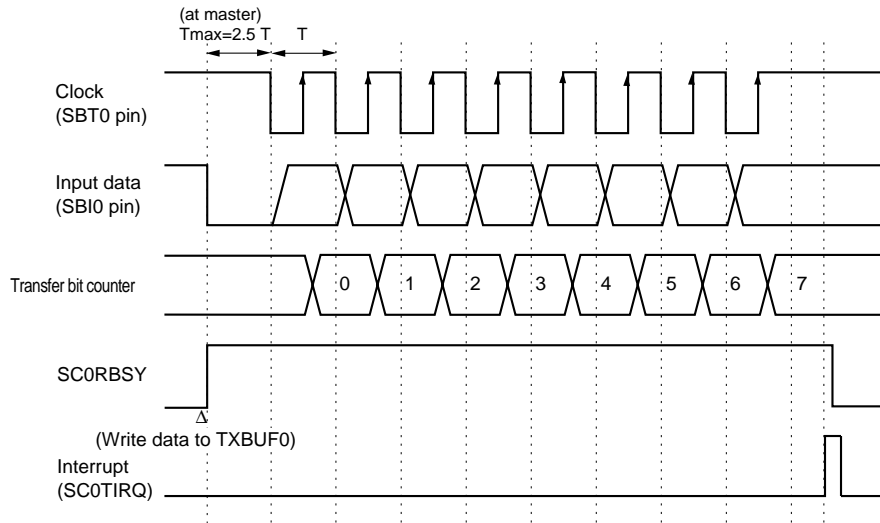


Figure 11-3-9 Reception Timing (rising edge, start condition is enabled)

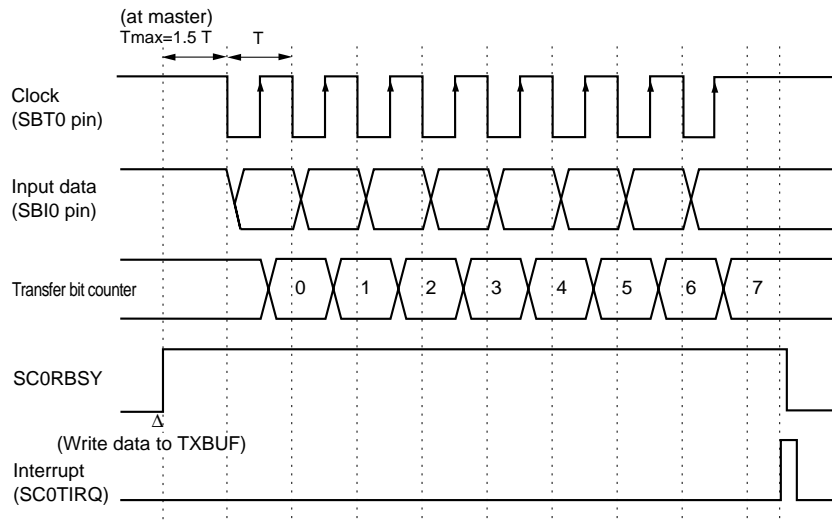
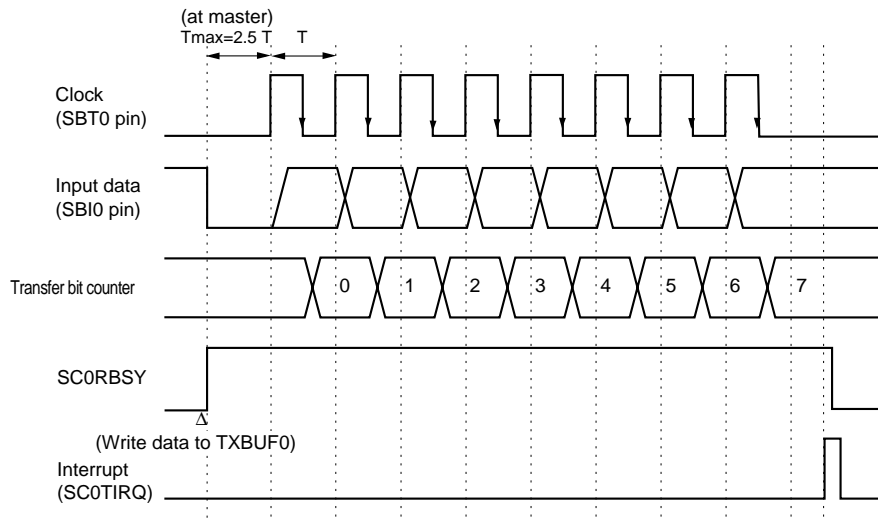
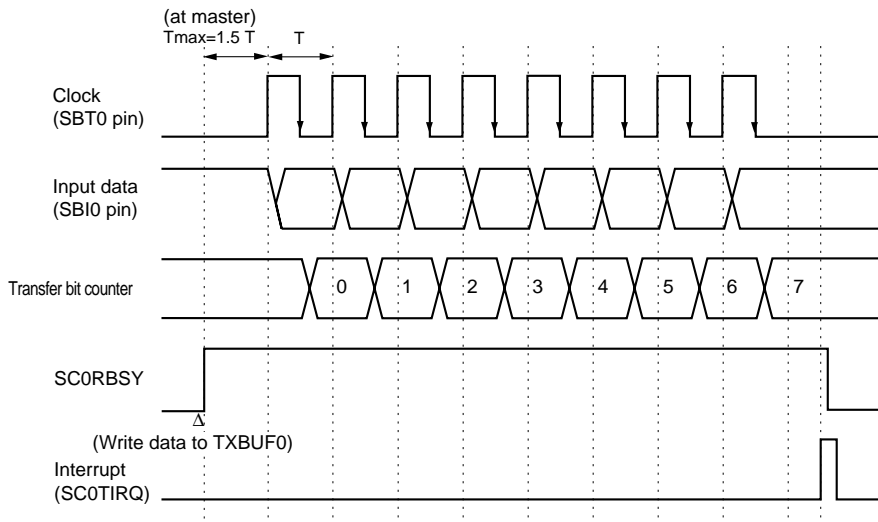


Figure 11-3-10 Reception Timing (rising edge, start condition is disabled)



**Figure 11-3-11 Reception Timing (falling edge, start condition is enabled)**

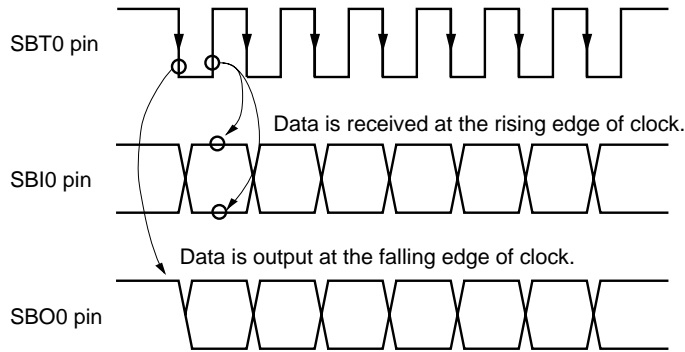


**Figure 11-3-12 Reception Timing (falling edge, start condition is disabled)**

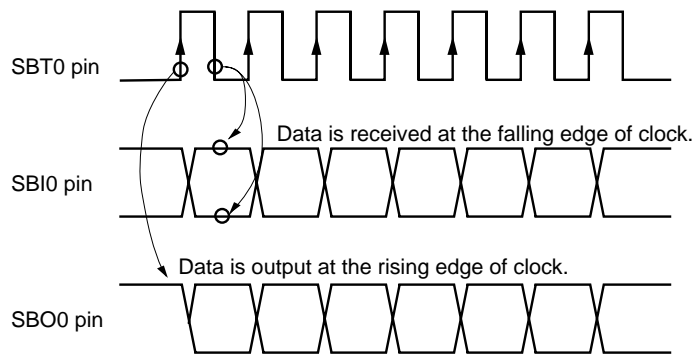


■Transmission / Reception Timing

When transmission and reception are operated at the same time, set the SC0CE1 flag of the SC0MD0 register to "0" or "1". Data is received at the opposite edge of the transmission clock, so that the reception clock should be the opposite edge of the transmission clock from the other side.



**Figure 11-3-13 Transmission / Reception Timing  
(Reception : rising edge, Transmission : falling edge)**



**Figure 11-3-14 Transmission / Reception Timing  
(Reception : falling edge, Transmission : rising edge)**

■Pins Setup (3 channels, at transmission)

Table 11-3-6 shows the setup for synchronous serial interface pin with 3 channels (SBO0 pin, SBI0 pin, SBT0 pin) at transmission.

**Table 11-3-6 Setup for Synchronous Serial Interface Pin (3 channels, at transmission)**

Setup item	Data output pin	Data input pin	Clock I/O pin	
	SBO0 pin	SBI0 pin	SBT0 pin	
			Internal clock	External clock
Pin	P00	P01	P02	
SBI0 / SBO0 pin	SBI0 / SBO0 independent		-	
	SC0MD1(SC1IOM)			
Function	Serial data output	"1" input	Serial clock I/O	Serial clock I/O
	SC0MD1(SC0SBOS)	SC0MD1(SC0SBIS)	SC0MD1(SC0SBTS)	
Style	Push-pull / Nch open-drain	-	Push-pull / Nch open-drain	Push-pull / Nch open-drain
	SC0ODC(SC0ODC0)		SC0ODC(SC0ODC1)	
I/O	Output mode	-	Output mode	Input mode
	P0DIR(P0DIR0)		P0DIR(P0DIR2)	
Pull-up	Added / Not added	-	Added / Not added	Added / Not added
	P0PLU(P0PLU0)		P0PLU(P0PLU2)	

■Pins Setup (3 channels, at reception)

Table 11-3-7 shows the setup for synchronous serial interface pin with 3 channels (SBO0 pin, SBI0 pin, SBT0 pin) at reception.

**Table 11-3-7 Setup for Synchronous Serial Interface Pin (3 channels, at reception)**

Setup item	Data output pin	Data input pin	Clock I/O pin	
	SBO0 pin	SBI0 pin	SBT0 pin	
			Internal clock	External clock
Pin	P00	P01	P02	
SBI0 / SBO0 pin	SBI0 / SBO0 independent		-	
	SC0MD1(SC0IOM)			
Function	Port	Serial data input	Serial clock I/O	Serial clock I/O
	SC0MD1(SC0SBOS)	SC0MD1(SC0SBIS)	SC0MD1(SC0SBTS)	
Style	-	-	Push-pull / Nch open-drain	Push-pull / Nch open-drain
			SC0ODC(SC0ODC1)	
I/O	-	Input mode	Output mode	Input mode
		P0DIR(P0DIR1)	P0DIR(P0DIR2)	
Pull-up	-	-	Added / Not added	Added / Not added
			P0PLU(P0PLU2)	

■ Pins Setup (3 channels, at transmission / reception)

Table 11-3-8 shows the setup for synchronous serial interface pin with 3 lines (SBO0 pin, SBI0 pin, SBT0 pin) at transmission / reception.

**Table 11-3-8 Setup for Synchronous Serial Interface Pin  
(3 channels, at transmission / reception)**

Setup item	Data output pin	Data input pin	Clock I/O pin	
	SBO0 pin	SBI0 pin	SBT0 pin	
			Internal clock	External clock
Pin	P00	P01	P02	
SBI0 / SBO0 pin	SBI0 / SBO0 independent		-	
	SC0MD1(SC0IOM)			
Function	Serial data output	Serial data input	Serial clock I/O	Serial clock I/O
	SC0MD1(SC0SBOS)	SC0MD1(SC0SBIS)	SC0MD1(SC0SBTS)	
Style	Push-pull / Nch open-drain	-	Push-pull / Nch open-drain	Push-pull / Nch open-drain
	SC0ODC(SC0ODC0)		SC0ODC(SC0ODC1)	
I/O	Output mode	Input mode	Output mode	Input mode
	P0DIR(P0DIR0)	P0DIR(P0DIR1)	P0DIR(P0DIR2)	
Pull-up	Added / Not added	-	Added / Not added	Added / Not added
	P0PLU(P0PLU0)		P0PLU(P0PLU2)	

■ Pins Setup (2 channels, at transmission)

Table 11-3-9 shows the setup for synchronous serial interface pin with 2 channels (SBO0 pin, SBT0 pin) at transmission. SBI0 pin can be used as a general port.

**Table 11-3-9 Setup for Synchronous Serial Interface Pin (2 channels, at transmission)**

Setup item	Data output pin		Clock I/O pin	
	SBO0 pin	SBI0 pin	SBT0 pin	
			Internal clock	External clock
Pin	P00		P02	
SBI0 / SBO0 pin	SBI0/SBO0 connected		-	
	SC0MD1(SC0IOM)			
Function	Serial data output	"1" input	Serial clock I/O	Serial clock I/O
	SC0MD1(SC0SBOS)	SC0MD1(SC0SBIS)	SC0MD1(SC0SBTS)	
Style	Push-pull / Nch open-drain	-	Push-pull / Nch open-drain	Push-pull / Nch open-drain
	SC0ODC(SC0ODC0)		SC0ODC(SC0ODC1)	
I/O	Output mode	-	Output mode	Input mode
	P0DIR(P0DIR0)		P0DIR(P0DIR2)	
Pull-up	Added / Not added	-	Added / Not added	Added / Not added
	P0PLU(P0PLU0)		P0PLU(P0PLU2)	

■ Pins Setup (2 channels, at reception)

Table 11-3-10 shows the setup for synchronous serial interface pin with 2 channels (SBO0 pin, SBT0 pin) at reception. SBI0 pin can be used as a general port.

**Table 11-3-10 Setup for Synchronous Serial Interface Pin (2 channels, at reception)**

Setup item	Data input pin		Clock I/O pin	
	SBO0 pin	SBI0 pin	SBT0 pin	
			Internal clock	External clock
Pin	P00		P02	
SBI0 / SBO0 pin	SBI0 / SBO0 connected		-	
	SC0MD1(SC0IOM)			
Function	Port	Serial data input	Serial clock I/O	Serial clock I/O
	SC0MD1(SC0SBOS)	SC0MD1(SC0SBIS)	SC0MD1(SC0SBTS)	
Style	-	-	Push-pull / Nch open-drain	Push-pull / Nch open-drain
			SC0ODC(SC0ODC1)	
I/O	Input mode	-	Output mode	Input mode
	P0DIR(P0DIR0)		P0DIR(P0DIR2)	
Pull-up	-	-	Added / Not added	Added / Not added
			P0PLU(P0PLU2)	

## 11-3-2 Setup Example

### ■Transmission / Reception Setup Example

The setup example for clock synchronous serial communication with serial 0 is shown. Table 11-3-11 shows the conditions at transmission / reception.


**Table 11-3-11 Setup Examples for Synchronous Serial Interface Transmission / Reception**

Setup item	set to	Setup item	set to
SBI0 / SBO0 pin	Independent (with 3 channels)	Clock source	fs/2
Transfer bit count	8 bits	Clock source 1/8 dividing	divided by 8
Start condition	none	SBT0 / SBO0 pin style	Nch open-drain
First transfer bit	MSB	SBT0 pin pull-up resistor	Added
Input clock edge	falling edge	SBO0 pin pull-up resistor	Added
Output clock edge	rising edge	Serial 0 communication complete interrupt	Enable
Clock	Internal clock		

An example setup procedure, with a description of each step is shown below.

Setup Procedure	Description
(1) Select the prescaler operation. PSCMD (x'3F6F') bp0 : PSCEN = 1	(1) Set the PSCEN flag of the PSCMD register to "1" to select "prescaler operation".
(2) Select the clock source. SC0CKS (x'3F97') bp2-0 : SC0PSC2-0 = 100 bp3 : SC0TMSEL = 0	(2) Select the clock source by the SC0CKS register. Set bp3-0 to "0100" to select "fs/2".
(3) Control the pin type. SC0ODC (x'3F96') bp1-0 : SC0ODC1-0 = 11 P0PLU (x'3F40') bp2, 0 : P3PLU2, 0 = 1, 1	(3) Set the SC0ODC1-0 flag of the SC0ODC register to "11" to select "N-ch open drain" to the SBO0/SBT0 pin. Set the P0PLU2, 0 flag of the P0PLU register to "1, 1" to add pull-up resistor.
(4) Control the pin direction. P0DIR (x'3F30') bp2-0 : P0DIR2-0 = 101	(4) Set the P0DIR2-0 flag of the port 0 pin's direction control register (P0DIR) to "101" to set P00, P02 "output mode", and to set P01 "input mode".
(5) Set the SC0MD0 register. Select the transfer bit count. SC0MD0 (x'3F90')	(5) Set the SC0LNG2-0 flag of the serial 0 mode register (SC0MD0) to "111" to set the transfer bit count "8 bits".

Setup Procedure	Description
Select the start condition. SC0MD0 (x'3F90') bp3 : SC0STE = 0	Set the SC0STE flag of the SC0MD0 register to "0" to disable start condition.
Select the first bit to be transferred. SC0MD0 (x'3F90') bp4 : SC0DIR = 0	Set the SC0DIR flag of the SC0MD0 register to "0" to set MSB as a transfer first bit.
Select the transfer edge. SC0MD0 (x'3F90') bp7 : SC0CE1 = 1	Set the SC0CE1 flag of the SC0MD0 register to "1" to set the transmission data output edge "rising" and the received data input edge "falling".
(6) Set the SC0MD2 register. Control the output data. SC0MD2 (x'3F92') bp0 : SC0BRKE = 0	(6) Set the SC0BRKE flag of the SC0MD2 register to "0" to select "serial data transmission".
Set other mode registers. SC0MD2 (x'3F92') bp7-3	No need at synchronous serial communication.
(7) Set the SC0MD1 register. Select the communication type. SC0MD1 (x'3F91') bp0 : SC0CMD = 0	(7) Set the SC0CMD flag of the SC0MD1 register to "0" to select "synchronous serial".
Select the transfer clock. SC0MD1 (x'3F91') bp2 : SC0MST = 1 bp3 : SC0CKM = 1	Set the SC0MST flag of the SC0MD1 register to "1" to select clock master (inside clock). Set the SC0CKM flag to "1" to select "divide by 8" for source clock.
Control the pin function. SC0MD1 (x'3F91') bp4 : SC0SBOS = 1 bp5 : SC0SBIS = 1 bp6 : SC0SBTS = 1 bp7 : SC0IOM = 0	Set the SC0SBOS, SC0SBIS, SC0SBTS flag of the SC0MD1 register to "1" to set SBO0 pin "serial data output", SBI0 pin "serial data input", and SBT0 pin "serial clock I/O". Set the SC0IOM flag "0" to set serial data input from SBI0 pin.
(8) Set the interrupt level. SC0TICR (x'3FF6') bp7-6 : SC0TLV1-0 = 10	(8) Set the interrupt level by the SC0TLV1-0 flag of the serial 0 transmission interrupt control register (SC0TICR). (Set level 2.)

Setup Procedure	Description
<p>(9) Enable the interrupt. SC0TICR (x'3FF6') bp1 : SC0TIE = 1</p> <p>(10) Start serial transmission. Transmission data→TXBUF0 (x'3F95') Received data→input to SBI0 pin.</p>	<p>(9) Set the SC0TIE flag of the SC0TICR register to "1" to enable interrupts. If any interrupt request flag (SC0TIR of the SC0TICR register) is already set, clear SC0TIR before an interrupt is enabled. [  Chapter 3 3-1-4. Interrupt Flag Setup ]</p> <p>(10) Set the transmission data to the serial transmission data buffer TXBUF0. Then, an internal clock is generated to start transmission / reception. After the transmission is finished, serial0 transmission interrupt SC0TIRQ is generated.</p>

Note : In (5) to (7), each settings can be set at once.



When only reception with 3 channels is operated, set SC0SBOS of the SC0MD1 register to "0" and select a port. The SBO0 pin can be used as a general port.



When SBO0 / SBI0 pin are connected for communication with 2 lines, the SBO0 pin inputs / outputs serial data. The port direction control register P0DIR switches I/O. At reception, set SC0SBIS of the SC0MD1 register to "1", always, to select "serial data input". The SBI0 pin can be used as a general port.



It is possible to shut down communication. If the communication should be stopped by force, set SC0SBOS and SC0SBIS of the SC0MD1 register to "0".



Each flag should be set as the procedure in order. Activation for communication should be operated after all control registers (except Table 11-2-1 : TXBUF0, RXBUF0) are set.



Transfer rate of transfer clock that set by SC0CKS register should be under 2.5 MHz.



When timer output is selected as serial interface transfer clock, select fosc as a clock source of the timer. If other clock is selected, normal transfer of serial interface data is not guaranteed.

### 11-3-3 UART Serial Interface

Serial 0 can be used for duplex UART communication. Table 11-3-12 shows UART serial interface functions.

**Table 11-3-12 UART Serial Interface Functions**

Communication style	UART(duplex)
Interrupt	SC0TIRQ(transmission), SC0RIRQ(reception)
Used pins	TXD0(output, input) RXD0(input)
Specification the first transfer bit	MSB / LSB
Selection of parity bit	√
Parity bit control	0 parity 1 parity odd parity even parity
Frame selection	7 bits + 1 stop 7 bits + 2 stops 8 bits + 1 stop 8 bits + 2 stops
Continuous operation	√
Continuous operation (with ATC)	√
Maximum transfer rate	300 kbps (standard 300 bps to 38.4 kbps) (with baud rate timer)



#### ■Activation Factor for Communication

At transmission, if any data is written to the transmission data buffer TXBUF0, a start condition is generated to start transfer. At reception, if a start condition is received, communication is started. At reception, if the data length of "L" for start bit is longer than 0.5 bit, that can be regarded as a start condition.

#### ■Transmission

Data transfer is automatically started by writing data to the transmission data buffer TXBUF0. When the transmission has completed, the serial 0 transmission interrupt SC0TIRQ is generated.

#### ■Reception

Once a start condition is received, reception is started after the transfer bit counter that counts transfer bit is cleared. When the reception is completed, the serial 0 reception interrupt SC0RIRQ is generated.

#### ■Duplex communication

Duplex communication, that the transmission and reception can be operated independently at the same time is available. On duplex communication, the frame mode and parity bit of the used data on transmission / reception should have the same polarity (refer to the cautions on XI-48).

#### ■Transfer Bit Count Setup

The transfer bit count is automatically set after the frame mode is specified by the SC0FM1 to 0 flag of the SC0MD2 register. If the SC0CMD flag of the SC0MD1 register is set to "1", and UART communication is selected, the setup by the synchronous serial data transfer bit count selection flag SC0LNG2 to 0 is no more valid.

#### ■Data Input Pin Setup

The communication mode can be selected from with 2 channels (data output pin (TXD0 pin), data input pin (RXD0 pin)), or with 1 channel (data I/O pin TXD0 pin). The RXD0 pin can be used only for serial data input. The TXD0 pin can be used for serial data input or output. The SC0IOM flag of the SC0MD1 register can specify which pin, RXD0 or TXD0 to input the serial data. "Data input from TXD0 pin" is selected to be with 1 channel communication, transmission / reception is switched by controlling TXD0 pin's direction by the P0DIR0 flag of the P0DIR register. At that time, the RXD0 pin can be used as a general port.

#### ■Received Buffer Empty Flag

When the communication complete interrupt SC0RIRQ is generated, data is stored to RXBUF0 from the internal shift register, automatically. If data is stored to the shift register RXBUF0, the received buffer empty flag SC0REMP of the SC0STR register is set to "1". This indicates that the reception data is going to be read. SC0REMP is cleared to "0" by reading data in RXBUF0.

■ Reception BUSY flag

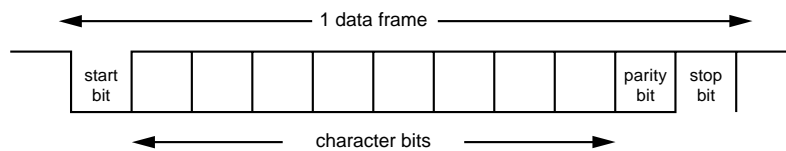
When the start condition is regarded, the SC0RBSY flag of the SC0STR register is set to "1". That is cleared to "0" by the generation of the reception complete interrupt SC0RIRQ. If, during reception, the SC0SBIS flag is set to "0", the SC0RBSY flag is reset to "0".

■ Transmission BUSY flag

When any data is set to TXBUF0, the SC0TBSY flag of the SC0STR register is set to "1". That is cleared to "0" by the generation of the transmission complete interrupt SC0TIRQ. During continuous communication the SC0TBSY flag is always set. If the transmission buffer empty flag S0TEMP is set to "0" as the transmission complete interrupt SC0TIRQ is generated, the SC0TBSY is cleared to "0". If the SC0SBOS flag is set to "0", the SC0TBSY flag is reset to "0".

■ Frame Mode and Parity Check Setup

Figure 11-3-15 shows the data format at UART communication.



**Figure 11-3-15 UART Serial Interface Transmission / Reception Data Format**

The transmission / reception data consists of start bit, character bit, parity bit and stop bit. Table 11-3-13 shows its kinds to be set.

**Table 11-3-13 UART Serial Interface Transmission / Reception Data**

Start bit	1 bit
Character bit	7, 8 bits
Parity bit	fixed to 0, fixed to 1, even, odd, none
Stop bit	1, 2 bits

The SC0FM1 to 0 flag of the SC0MD2 register sets the frame mode. Table 11-3-14 is shown the UART Serial Interface Frame Mode setting. If the SC0CMD flag of the SC0MD1 register is set to "1", and UART communication is selected, the transfer bit count on the SC0LNG2 to 0 flag of the SC0MD0 register is no more valid.

**Table 11-3-14 UART Serial Interface Frame Mode**

SC0MD2 register		Frame mode
SC0FM1	SC0FM0	
0	0	Character bit 7 bits + Stop bit 1 bit
0	1	Character bit 7 bits + Stop bit 2 bits
1	0	Character bit 8 bits + Stop bit 1 bit
1	1	Character bit 8 bits + Stop bit 2 bits

Parity bit is to detect wrong bits with transmission / reception data.

Table 11-3-15 shows kinds of parity bit. The SC0NPE, SC0PM1 to 0 flag of the SC0MD2 register set parity bit.

**Table 11-3-15 Parity Bit of UART Serial Interface**

SC0MD2 register			Parity bit	Setup
SC0NPE	SC0PM1	SC0PM0		
0	0	0	fixed to 0	Set parity bit to "0".
0	0	1	fixed to 1	Set parity bit to "1".
0	1	0	odd parity	Control that the total of "1" of parity bit and character bit should be odd.
0	1	1	even parity	Control that the total of "1" of parity bit and character bit should be even.
1	-	-	none	Do not add parity bit.



Do not set following flame modes when SC0NPE flag is "1" and parity bit is disabled,  
 Character 7 bits + Stop 2 bits of the flame mode  
 (Set the SC0FM1, SC0FM0 flags to "0, 1".)  
 Character 7 bits + Stop 1 bit of the flame mode  
 (Set the SC0FM1, SC0FM0 flags to "0, 0".)

#### ■Break Status Transmission Control Setup

The SC0BRKE flag of the SC0MD2 register generates the break status. If SC0BRKE is set to "1" to select the break transmission, all bits from start bits to stop bits transfer "0".

■Reception Error

At reception , there are 3 types of error ; overrun error, parity error and framing error. Reception error can be determined by the SC0ORE, SC0PEK, SC0FEF flag of the SC0STR register. Even one of those errors is detected, the SC0ERE flag of the SC0STR register is set to "1". The SC0PEK, the SC0FEF flags in reception error flag are renewed at generation of the reception complete interrupt SC0RIRQ. The SC0ORE flag is holded the status unless data of RXBUF0 is read out. The judgements of the received error flag should be operated until the next communication is finished. The communication operation does not have any effect on those error flags . Table 11-3-16 shows the list of reception error source.

**Table 11-3-16 Reception Error Source of UART Serial Interface**

Flag	Error	Error source	
SC0ORE	Overrun error	Next data is received before reading the receive buffer.	
SC0PEK	Parity error	at fixed to 0	when parity bit is "1"
		at fixed to 1	when parity bit is "0"
		odd parity	The total of "1" of parity bit and character bit is even.
		even parity	The total of "1" of parity bit and character bit is odd.
SC0FEF	Framing error	Stop bit is not detected.	

■Judgement of Break Status Reception

Reception at break status can be judged. If all received data from start bit to stop bit is "0", the SC0BRKF flag of the SC0MD2 register is set and regard the break status. The SC0BRKF flag is set at generation of the reception complete interrupt SC0RIRQ.

■Sequence Communication

It is possible to transfer continuously. If data is set to the transmission data buffer TXBUF0 during communication, the transmission buffer empty flag SC0TEMP is set to continue the communication, automatically. In this case, there is no pause on communication. Data should be set to TXBUF0 after data is loaded to the inside shift register before the communication complete interrupt SC0TIRQ is generated.

Also, this LSI has an automatic data transfer function ATC1 that can be one of an activation factor. At activation by ATC1, data can be transfered up to 255 bytes, continuously. In this case, there is a communication blank ; up to 18 machine cycles + 3.5 bit data length. For an activation by ATC1, refer to chapter 15. automatic transfer controller, transfer mode 6 to 9.

**■Clock Setup**

At UART communication, the transfer clock is not needed, but the clock setup should be needed to decide the timing of the data transmission / reception in the serial interface.

Select the timer to be used as a baud rate timer, by the SC0CKS register, and set the SC0MST flag of the SC0MD1 register to "1" to select the internal clock (clock master).



At UART communication, set the SC0MST flag of the SC0MD1 register to "1". If that is set to "0", the communication is impossible.



When timer output is selected as serial interface transfer clock, select fosc as a clock source of the timer. If other clock is selected, normal transfer of serial interface data is not guaranteed.

■Transfer Bit Count and First Transfer Bit

When the transfer bit is 7 bits, the data storing method to the transmission data buffer TXBUF0 is different, depending on the first transfer bit selection. At MSB first, use the upper bits of TXBUF0 for storing. When there are 7 bits to be transfered, as shown on figure 11-3-16, if data "A" to "G" are stored to bp1 to bp7 of TXBUF0, the transmission is operated from "G" to "A". At LSB first, use the lower bits of TXBUF0 for storing. When there are 7 bits to be transfered, as shown on figure 11-3-17, if data "A" to "G" are stored to bp0 to bp6 of TXBUF0, the transmission is operated from "A" to "G".

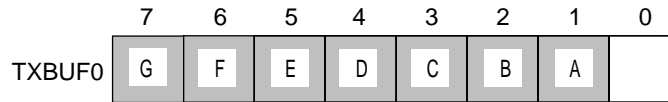


Figure 11-3-16 Transfer Bit Count and First Transfer Bit (starting with MSB)

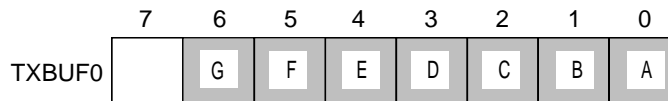


Figure 11-3-17 Transfer Bit Count and First Transfer Bit (starting with LSB)

■Receive Bit Count and First Transfer Bit

When the transfer bit count is 7 bits, the data storing method to the received data buffer RXBUF0 is different depending on the first transfer bit selection. At MSB first, data are stored to the upper bits of RXBUF0. When there are 7 bits to be transfered, as shown on figure 11-3-18, if data "G" to "A" are stored to bp7 to bp1 of RXBUF0. At LSB first, data are stored to the lower bits of RXBUF0. When there are 7 bits to be transfered, as shown on figure 11-3-19, if data "A" to "G" are stored to bp0 to bp6 of RXBUF0.

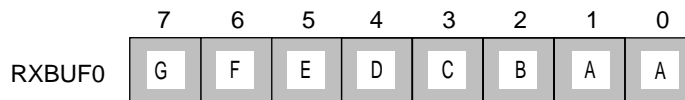


Figure 11-3-18 Receive Bit Count and Transfer First Bit (starting with MSB bit)

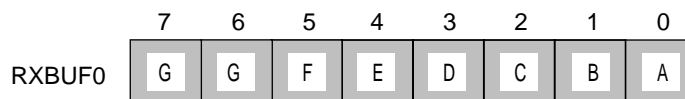


Figure 11-3-19 Receive Bit Count and Transfer First Bit (starting with LSB bit)

The following items are same to clock synchronous serial.

Reference as follows ;

■First Transfer Bit Setup

Refer to : XI-13

■Transmission Data Buffer

Refer to : XI-13

■Received Data Buffer

Refer to : XI-13

■Transfer Bit Count and First Transfer Bit

Refer to : XI-14

■Receive Bit Count and First Transfer Bit

Refer to : XI-14

■Transmission Buffer Empty Flag

Refer to : XI-17

■Emergency Reset

Refer to : XI-18

■ Transmission Timing

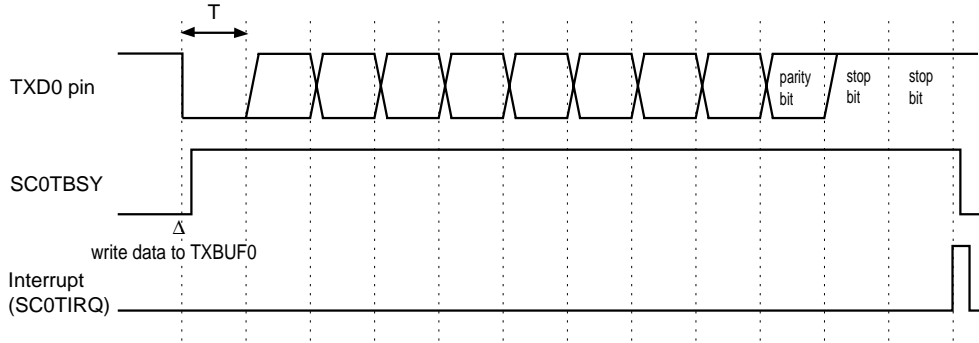


Figure 11-3-20 Transmission Timing (parity bit is enabled)

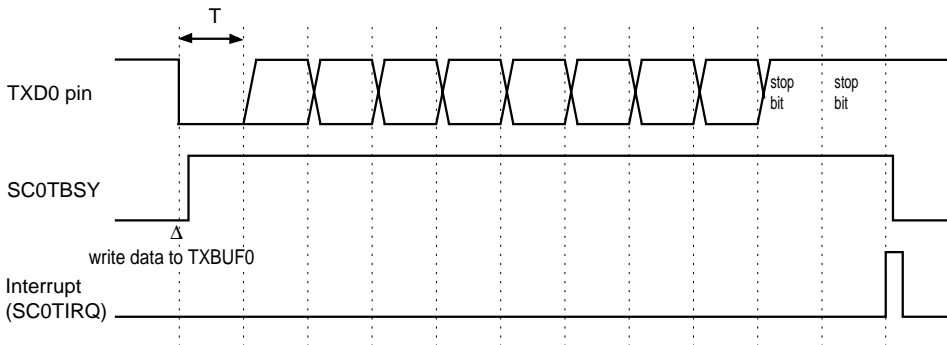


Figure 11-3-21 Transmission Timing (parity bit is disabled)



■ Reception Timing

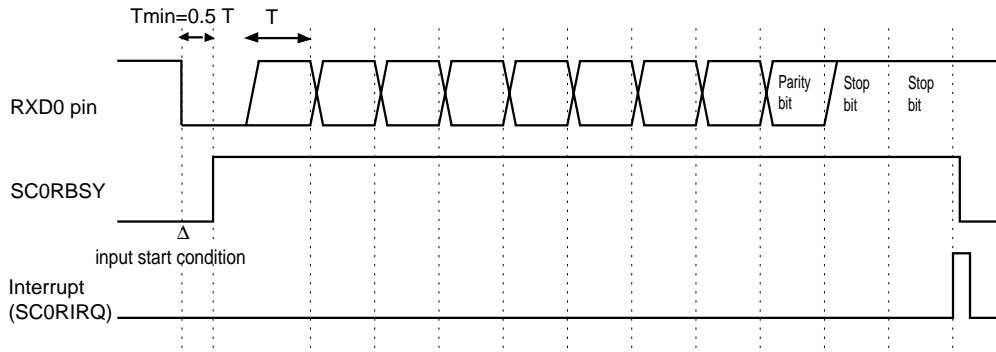


Figure 11-3-22 Reception Timing (parity bit is enabled)

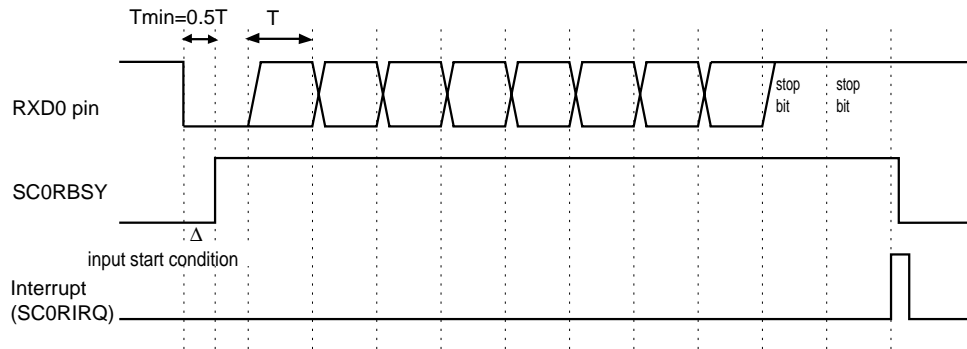


Figure 11-3-23 Reception Timing (parity bit is disabled)

■Transfer Rate

Baud rate timer (timer 2 and timer 4) can set any transfer rate.

Table 11-3-17 shows the setup example of the transfer rate. For detail of the baud rate timer setup, refer to chapter 6. 6-8 serial transfer clock output operation.

**Table 11-3-17 UART Serial Interface Transfer Rate Setup Register**

Setup	Register	Page
Serial 0 clock source (timer 2, 4 output)	SC0CKS	XI - 11
Timer 2 clock source	TM2MD	VI - 13
Timer 2 compare register	TM2OC	VI - 9
Timer 4 clock source	TM4MD	VI - 15
Timer 4 compare register	TM4OC	VI - 9

Timer 4 compare register is set as follows ;

$$\text{overflow cycle} = (\text{set value of compare register} + 1) \times \text{timer clock cycle}$$

$$\text{baud rate} = 1 / (\text{overflow cycle} \times 2 \times 8) \text{ ("8" means that clock source is divided by 8)}$$


therefore,

$$\text{set value of compare register} = \text{timer clock frequency} / (\text{baud rate} \times 2 \times 8) - 1$$

For example, if baud rate should be 300 bps at timer clock source  $f_s/4$  ( $f_{osc} = 8 \text{ MHz}$ ,  $f_s = f_{osc}/2$ ), set value should be as follows ;

$$\begin{aligned} \text{Set value of compare register} &= (8 \times 10^6 / 2 / 4) / (300 \times 2 \times 8) - 1 \\ &= 207 \\ &= \text{x'CF'} \end{aligned}$$

Timer clock source and the set values of timer compare register at the standard rate are shown on the following page.

 Transfer rate should be selected under 300 kbps.


 When timer output is selected as serial interface transfer clock, select  $f_{osc}$  as a clock source of the timer. If other clock is selected, normal transfer of serial interface data is not guaranteed.

Table 11-3-18-1 UART Serial Interface Transfer Rate (decimal)

fosc (MHz)	Clock source (timer)	Transfer rate (bps)									
		300		960		1200		2400		4800	
		Set value	Calculated Value	Set value	Calculated Value	Set value	Calculated Value	Set value	Calculated Value	Set value	Calculated Value
4.00	fosc	-	-	-	-	207	1202	103	2404	51	4808
	fosc/4	207	300	64	962	51	1202	25	2404	12	4808
	fosc/16	51	300	-	-	12	1202	-	-	-	-
	fosc/32	25	300	-	-	-	-	-	-	-	-
	fosc/64	12	300	-	-	-	-	-	-	-	-
	fs/2	207	300	64	962	51	1202	25	2404	12	4808
	fs/4	104	297	-	-	25	1202	12	2404	-	-
4.19	fosc	-	-	-	-	217	1201	108	2403	54	4761
	fosc/4	217	300	67	963	-	-	-	-	-	-
	fosc/16	-	-	16	963	-	-	6	2338	-	-
	fosc/32	-	-	-	-	-	-	-	-	-	-
	fosc/64	-	-	-	-	-	-	-	-	-	-
	fs/2	217	300	67	963	-	-	-	-	-	-
	fs/4	108	300	33	963	-	-	13	2338	-	-
8.00	fosc	-	-	-	-	-	-	207	2404	103	4808
	fosc/4	-	-	129	962	103	1202	51	2404	25	4808
	fosc/16	103	300	-	-	25	1202	12	2404	-	-
	fosc/32	51	300	-	-	12	1202	-	-	-	-
	fosc/64	25	300	-	-	-	-	-	-	-	-
	fs/2	-	-	129	962	103	1202	51	2404	25	4808
	fs/4	207	300	64	962	51	1202	25	2404	12	4808
8.38	fosc	-	-	-	-	-	-	217	2403	108	4805
	fosc/4	-	-	135	963	108	1201	-	-	-	-
	fosc/16	108	300	33	963	-	-	13	2338	-	-
	fosc/32	-	-	16	963	-	-	6	2338	-	-
	fosc/64	-	-	-	-	-	-	-	-	-	-
	fs/2	-	-	135	963	108	1201	-	-	-	-
	fs/4	217	300	67	963	-	-	-	-	-	-
12.00	fosc	-	-	-	-	-	-	-	-	155	4808
	fosc/4	-	-	194	962	155	1202	77	2404	38	4808
	fosc/16	155	300	-	-	38	1202	-	-	-	-
	fosc/32	77	300	-	-	-	-	-	-	-	-
	fosc/64	38	300	-	-	-	-	-	-	-	-
	fs/2	-	-	194	962	155	1202	77	2404	38	4808
	fs/4	-	-	-	-	77	1202	38	2404	-	-
16.00	fosc	-	-	-	-	-	-	-	-	207	4808
	fosc/4	-	-	-	-	207	1202	103	2404	51	4808
	fosc/16	207	300	64	962	51	1202	25	2404	12	4808
	fosc/32	103	300	-	-	25	1202	12	2404	-	-
	fosc/64	51	300	-	-	12	1202	-	-	-	-
	fs/2	-	-	-	-	207	1202	103	2404	51	4808
	fs/4	-	-	129	962	103	1202	51	2404	25	4808
16.76	fosc	-	-	-	-	-	-	-	-	-	-
	fosc/4	-	-	-	-	217	1201	108	2403	54	4761
	fosc/16	217	300	67	963	-	-	-	-	-	-
	fosc/32	108	300	33	963	-	-	-	-	-	-
	fosc/64	-	-	16	963	-	-	-	-	-	-
	fs/2	-	-	-	-	217	1201	108	2403	54	4761
	fs/4	-	-	135	963	108	1201	54	2381	-	-
20.00	fosc	-	-	-	-	-	-	-	-	-	-
	fosc/4	-	-	-	-	-	-	129	2404	64	4808
	fosc/16	-	-	-	-	64	1202	-	-	-	-
	fosc/32	129	300	-	-	-	-	-	-	-	-
	fosc/64	64	300	-	-	-	-	-	-	-	-
	fs/2	-	-	-	-	-	-	129	2404	64	4808
	fs/4	-	-	162	959	129	1202	64	2404	-	-

**Table 11-3-18-2 UART Serial Interface Transfer Rate (decimal)**

fosc (MHz)	Clock source (timer)	Transfer rate (bps)									
		9600		19200		28800		31250		38400	
		Set value	Calculated Value	Set value	Calculated Value	Set value	Calculated Value	Set value	Calculated Value	Set value	Calculated Value
4.00	fosc	25	9615	12	19231	-	-	7	31250	-	-
	fosc/4	-	-	-	-	-	-	1	31250	-	-
	fosc/16	-	-	-	-	-	-	-	-	-	-
	fosc/32	-	-	-	-	-	-	-	-	-	-
	fosc/64	-	-	-	-	-	-	-	-	-	-
	fs/2	-	-	-	-	-	-	1	31250	-	-
	fs/4	-	-	-	-	-	-	-	-	-	-
4.19	fosc	26	9699	-	-	-	-	-	-	-	-
	fosc/4	-	-	-	-	-	-	-	-	-	-
	fosc/16	-	-	-	-	-	-	-	-	-	-
	fosc/32	-	-	-	-	-	-	-	-	-	-
	fosc/64	-	-	-	-	-	-	-	-	-	-
	fs/2	-	-	-	-	-	-	-	-	-	-
	fs/4	-	-	-	-	-	-	-	-	-	-
8.00	fosc	51	9615	25	19231	-	-	15	31250	12	38462
	fosc/4	12	9615	-	-	-	-	3	31250	-	-
	fosc/16	-	-	-	-	-	-	-	-	-	-
	fosc/32	-	-	-	-	-	-	-	-	-	-
	fosc/64	-	-	-	-	-	-	-	-	-	-
	fs/2	12	9615	-	-	-	-	3	31250	-	-
	fs/4	-	-	-	-	-	-	1	31250	-	-
8.38	fosc	54	9523	26	19398	-	-	-	-	-	-
	fosc/4	-	-	-	-	-	-	-	-	-	-
	fosc/16	-	-	-	-	-	-	-	-	-	-
	fosc/32	-	-	-	-	-	-	-	-	-	-
	fosc/64	-	-	-	-	-	-	-	-	-	-
	fs/2	-	-	-	-	-	-	-	-	-	-
	fs/4	-	-	-	-	-	-	-	-	-	-
12.00	fosc	77	9615	38	19231	25	28846	23	31250	-	-
	fosc/4	-	-	-	-	-	-	5	31250	-	-
	fosc/16	-	-	-	-	-	-	-	-	-	-
	fosc/32	-	-	-	-	-	-	-	-	-	-
	fosc/64	-	-	-	-	-	-	-	-	-	-
	fs/2	-	-	-	-	-	-	5	31250	-	-
	fs/4	-	-	-	-	-	-	2	31250	-	-
16.00	fosc	103	9615	51	19231	-	-	31	31250	25	38462
	fosc/4	25	9615	12	19231	-	-	7	31250	-	-
	fosc/16	-	-	-	-	-	-	-	-	-	-
	fosc/32	-	-	-	-	-	-	-	-	-	-
	fosc/64	-	-	-	-	-	-	-	-	-	-
	fs/2	25	9615	-	-	-	-	7	31250	-	-
	fs/4	12	9615	-	-	-	-	3	31250	-	-
16.76	fosc	108	9610	54	19045	-	-	-	-	-	-
	fosc/4	26	9699	-	-	-	-	-	-	-	-
	fosc/16	-	-	-	-	-	-	-	-	-	-
	fosc/32	-	-	-	-	-	-	-	-	-	-
	fosc/64	-	-	-	-	-	-	-	-	-	-
	fs/2	26	9699	-	-	-	-	-	-	-	-
	fs/4	-	-	-	-	-	-	-	-	-	-
20.00	fosc	129	9615	64	19231	-	-	39	31250	-	-
	fosc/4	-	-	-	-	-	-	9	31250	-	-
	fosc/16	-	-	-	-	-	-	-	-	-	-
	fosc/32	-	-	-	-	-	-	-	-	-	-
	fosc/64	-	-	-	-	-	-	-	-	-	-
	fs/2	-	-	-	-	-	-	9	31250	-	-
	fs/4	-	-	-	-	-	-	4	31250	-	-

■Pin Setup (1, 2 channels, at transmission)

Table 11-3-19 shows the pins setup at UART serial interface transmission. The pins setup is common to the TXD0 pin, RXD0 pin, regardless of those pins are independent / connected.

**Table 11-3-19 UART Serial Interface Pin Setup (1, 2 channels, at transmission)**

Setup item	Data output pin	Data input pin
	TXD0 pin	RXD0 pin
Pin	P00	P01
TXD0 / RXD0 pins	TXD0 / RXD0 pins connected or independent	
	SC0MD1(SC0IOM)	
Function	Serial data output	"1" input
	SC0MD1(SC0SBOS)	SC0MD1(SC0SBIS)
Style	Push-pull / Nch open-drain	-
	SC0ODC(SC0ODC0)	
I/O	Output mode	-
	P0DIR(P0DIR0)	
Pul-up	Added / Not added	-
	P0PLU(P0PLU0)	

■Pin Setup (2 channels, at reception)

Table 11-3-20 shows the pins setup at UART serial interface reception with 2 channels (TXD0 pin, RXD0 pin).

**Table 11-3-20 UART Serial Interface Pin Setup (2 channels, at reception)**

Setup item	Data output pin	Data input pin
	TXD0 pin	RXD0 pin
Pin	P00	P01
TXD0 / RXD0 pin	TXD0 / RXD0 pins connected or independent	
	SC0MD1(SC0IOM)	
Function	port	serial data input
	SC0MD1(SC0SBOS)	SC0MD1(SC0SBIS)
Style	-	-
I/O	-	input mode
	-	P0DIR(P0DIR1)
Pull-up	-	-

■Pin Setup (1 channel, at reception)

Table 11-3-21 shows the pin setup at UART serial interface reception with 1 channel (TXD0 pin). The RXD0 pin is not used, so can be used as a port.

**Table 11-3-21 UART Serial Interface Pin Setup (1 channel, at reception)**

Setup item	Data output pin	Data input pin
	TXD0 pin	RXD0 pin
Pin	P00	P01
TXD0 / RXD0 pin	TXD0 / RXD0 pins connected	
	SC0MD1(SC0IOM)	
Function	Port	Serial data input
	SC0MD1(SC0SBOS)	SC0MD1(SC0SBIS)
Style	-	-
I/O	Input mode	-
	P0DIR(P0DIR0)	-
Pull-up	-	-

■Pin Setup (2 channels, at transmission / reception)

Table 11-3-22 shows the pin setup at UART serial interface transmission / reception with 2 channels (TXD0 pin, RXD0).

**Table 11-3-22 UART Serial Interface Pin Setup (2 channels, at transmission / reception)**

Setup item	Data output pin	Data input pin
	TXD0 pin	RXD0 pin
Pin	P00	P01
TXD0 / RXD0 pins	TDX0 / RXD0 pins independent	
	SC0MD1(SC0IOM)	
Function	Serial data output	Serial data input
	SC0MD1(SC0SBOS)	SC0MD1(SC0SBIS)
Style	Push-pull / Nch open-drain	-
	SC0ODC(SC0ODC0)	
I/O	Output mode	Input mode
	P0DIR(P0DIR0)	P0DIR(P0DIR1)
Pull-up	Added / Not added	-
	P0PLU(P0PLU0)	

## 11-3-4 Setup Example

### ■Transmission / Reception Setup

The setup example at UART transmission / reception with serial 0 is shown.


Table 11-3-23 shows the conditions at transmission / reception.

**Table 11-3-23 UART Interface Transmission Reception Setup**


Setup item	set to
TXD0 / RXD0 pin	independent (with 2 channels)
Frame mode specification	8 bits + 2 stop bits
First transfer bit	MSB
Clock source	timer 4
TXD0 / RXD0 pin type	Nch open-drain
Pull-up resistor of TXD0 pin	added
Parity bit add / check	"0"add / check
Serial interface 0 transmission complete interrupt	Enable.
Serial interface 0 reception complete interrupt	Enable.

An example setup procedure, with a description of each step is shown below.

Setup Procedure	Description
(1) Select prescaler operation. PSCMD (x'3F6F') bp0 : PSCEN = 1	(1) Set the PSCEN flag of the PSCMD register to "1" to select prescaler operation.
(2) Select the clock source. SC0CKS (x'3F97') bp2-0 : SC0PSC2-0 = 110 bp3 : SC0TMSEL = 1	(2) Set the bp3-0 flag of the SC0CKS register to "1110" to select timer 4 output as a clock source.
(3) Control the pin type. SC0ODC (x'3F96') bp0 : SC0ODC0 = 1 P0PLU (x'3F40') bp0 : P0PLU0 = 1	(3) Set the SC0ODC0 flag of the SC0ODC register to "1" to select N-ch open drain for the TXD0 pin. Set the P0PLU0 flag of the P0PLU register to "1" to add pull-up resistor.
(4) Control the pin direction. P0DIR (x'3F30') bp1-0 : P0DIR1-0 = 01	(4) Set the P0DIR1-0 flag of the port 0 pin direction control register (P0DIR) to "01" to set P00 to output mode, and P01 to input mode.
(5) Set the SC0MD0 register. Select the start condition. SC0MD0 (x'3F90') bp3 : SC0STE = 1	(5) Set the SC0STE flag of the SC0MD0 register to "1" to enable start condition.

Setup Procedure	Description
<p>Select the first bit to be transferred. SC0MD0 (x'3F90') bp4 : SC0DIR = 0</p> <p>(6) Set the SC0MD2 register. Control the output data. SC0MD2 (x'3F92') bp0 : SC0BRKE = 0</p> <p>Select the added parity bit. SC0MD2 (x'3F92') bp3 : SC0NPE = 0 bp5-4 : SC0PM1-0 = 00</p> <p>Specify the frame mode. SC0MD2 (x'3F92') bp7-6 : SC0FM1-0 = 11</p> <p>(7) Set the SC0MD1 register. Select the communication type. SC0MD1 (x'3F91') bp0 : SC0CMD = 1</p> <p>Select the clock frequency. SC0MD1 (x'3F91') bp3 : SC0CKM = 1 bp2 : SC0MST = 1</p> <p>Control the pin function. SC0MD1 (x'3F91') bp4 : SC0SBOS = 1 bp5 : SC0SBIS = 1 bp7 : SC0IOM = 0</p> <p>(8) Enable the interrupt. SC0RICR (x'3FF5') bp1 : SC0RIE = 1 SC0TICR (x'3FF6') bp1 : SC0TIE = 1</p>	<p>Set the SC0DIR flag of the SC0MD0 register to "0" to select MSB as first transfer bit.</p> <p>(6) Set the SC0BRKE flag of the SC0MD2 register to "0" to select serial data transmission.</p> <p>Set the SC0PM1-0 flag of the SC0MD2 register to "00" to select 0 parity, and set the SC0NPE flag to "0" to add parity bit.</p> <p>Set the SC0FM1-0 flag of the SC0MD2 register to "11" to select 8 bits + 2 stop bits at the frame mode.</p> <p>(7) Set the SC0CMD flag of the SC0MD1 register to "1" to select duplex UART.</p> <p>Set the SC0CKM flag of the SC0MD1 register to "1" to select "divided by 8" at source clock. And, the SC0MST flag should be always set to "1" to select colck master.</p> <p>Set the SC0SBOS, SC0SBIS flag of the SC0MD1 register to "1" to set the TXD0 pin to serial data output and the RXD0 pin to serial data input.</p> <p>(8) Set the SC0RIE flag of the SC0RICR register to "1", and set the SC0TIE flag of the SC0TICR register to "1" to enable the interrupt request. If any interrupt request flag is already set, clear them.</p> <p>[  Chapter 3. 3-1-4 Interrupt Flag Setup ]</p>



Setup Procedure	Description
<p>(14) Set the baud rate timer.</p> <p>(15) Start serial communication.  The transmission data → TXBUF0  (x'3F95')  The received data → input to RXD0</p>	<p>(14) Set the baud rate timer by the TM4MD register, the TM4OC register. Set the TM4EN flag to "1" to start timer 4.  [  Chapter 6. 6-8 Serial Transfer Clock ]</p> <p>(15) The transmission is started by setting the transmission data to the serial transmission data buffer (TXBUF0). When the transmission has finished, the serial 0 transmission interrupt (SC0TIRQ) is generated. After the serial data is input from the RXD0 pin and the start condition is recognized, the received data is stored. When the reception has finished, the received data is stored to the serial received data buffer RXBUF0 and the serial 0 reception data buffer interrupt SC0RICR is generated.</p>

Note : (5) to (6), (7) to (9), (10) to (12) can be set at once.



When the TXD0 / RXD0 pin are connected for communication with 1 channel, the TXD0 pin inputs / outputs serial data. The port direction control register P0DIR switches I/O. At reception, set SC0SBIOS of the SC0MD1 register to "1" to select serial data input. The RXD0 pin can be used as a general port.



It is possible to shut down the communication. If the communication should be stopped by force, set SC0SBOS and SC0SBIS of the SC0MD1 register to "0".



Each flag should be set as its procedure in order. Activation for communication should be operated after all control registers (except Table 11-2-1 : TXBUF0, RXBUF0) are set.



Only timer 2 and timer4 can be used as a baud rate timer.  
For baud rate setup, refer to Chapter 6. 6-8 Serial Transfer Clock Output.



When timer output is selected as serial interface transfer clock, select fosc as a clock source of the timer. If other clock is selected, normal transfer of serial interface data is not guaranteed.



In full-duplex UART communication using serial interface 0, abnormal reception may occur if data transmission is started during data reception (transmission data is set to transmission data buffer). Therefore, run the following program under the condition that data reception may occur. However, do not use full-duplex UART communication for sequence communication, as the software countermeasure cannot be used.

[Basic flow of countermeasure program]

- (1) Confirm reception status by SC0RBSY flag of SC0STR register before transmission data is set.
- (2) At SC0RBSY = 0(other use), set transmission data to TXBUF0.
- (3) At SC0RBSY = 1(serial reception in progress), wait until SC0RBSY = 0(other use).

[Examples of recommended program]

```

Label 1 tbnz (x'03F93') 6, Label 2      :(1) Branches to Label2 at SC0RBSY = 1
        mov '55', (x'03F95')          :(2) Set transfer data (x'55') to TXBUF0
        jmp Label 3                   :   Branches to Label3
Label 2 tbz (x'03F93') 6, Label 1      :(3) Branches to Label1 at SC0RBSY = 0
        loop Label 2
Label 3
    
```

- [\*1] To prevent abnormal operation, UART transfer rate must be set as follows even when data reception is started after reception status is confirmed (1) before transmission data is set (2).  
 transfer rate = selected clock frequency/8 ≤ fs/10 (fs:system clock frequency)  
 Selectable transfer clock sources are shown in following table.
- [\*2] Operation (2) needs to be executed right after the operation (1) is completed. During these procedure, prevent branching by disable interrupts or other methods.

System clock(fs)	Selectable serial interface 0 transfer clock source
fs=fosc	All clock sources
fs=fosc/2	fosc/4,fosc/16,fosc/64,fs/2,fs/4, baud rate timer output fulfill (*1)
fs=fosc/4	fosc/16,fosc/64,fs/4, baud rate timer output fulfill (*1)
fs=fosc/8	fosc/16,fosc/64, baud rate timer output fulfill (*1)
fs=fosc/16	fosc/64, baud rate timer output fulfill (*1)
fs=fosc/32	fosc/64, baud rate timer output fulfill (*1)
fs=fosc/64	baud rate timer output fulfill (*1)




# 12-1 Overview

This LSI contains a serial interface 1 can be used for both communication types of clock synchronous and UART (normal UART communication, and IC card communication).

## 12-1-1 Functions

Table 12-1-1 shows functions of serial interface 1.

**Table 12-1-1 Serial Interface 1 Functions**

Communication style	clock synchronous	UART (half-duplex)	IC card (UART)
Interrupt	SC1IRQ	SC1IRQ	SC1IRQ
Used pins	SBO1,SB1,SBT1	TXD1,RXD1	TXD1
3 channels type	√	-	-
2 channels type	√ (SBO1, SBT1)	√	-
1 channel type	-	√ (TXD1)	√ (TXD1)
Specification of transfer bit count / Frame selection	1 to 8 bits	7 bits + 1stop 7 bits + 2stops 8 bits + 1stop 8 bits + 2stops	8 bits + 2stops
Selection of parity bit	-	√	only "parity bit is added" is available
Parity bit control	-	0 parity 1 parity odd parity even parity	0 parity 1 parity odd parity even parity
Selection of start condition	√	only "enable start condition" is available	only "enable start condition" is available
Specification of the first transfer bit	√	√	√
Specification of input edge / output edge	√	-	√
Continuous operation	√	√	√
Continuous operation (with ATC1)	√	√	√
Internal clock 1/8 dividing	√	only 1/8 dividing is available	only 1/8 dividing is available
Clock source	fosc/2 fosc/4 fosc/16 fosc/64 fs/2 fs/4 Timer 4 output External clock	fosc/2 fosc/4 fosc/16 fosc/64 fs/2 fs/4 Timer 4 output	fosc/2 fosc/4 fosc/16 fosc/64 fs/2 fs/4 Timer 4 output
Maximum transfer rate	2.5 MHz	300 kbps (standard 300 bps to 38.4 kbps) (timer 4 output)	300 kbps (standard 300 bps to 38.4 kbps) (timer 4 output)
fosc : Machine clock (High speed oscillation) fs : System clock [  Chapter 2 2-5. Clock Switching ] Select "disable start condition", when the reception and the transmission are operated at the same time on the clock synchronous communication.			



## 12-2 Control Registers

### 12-2-1 Registers

Table 12-2-1 shows registers to control serial interface 1.

**Table 12-2-1 Serial Interface 1 Control Registers**

	Register	Address	R/W	Function	Page
Serial Interface 1	SC1MD0	x'03F9A'	R/W	Serial interface 1 mode register 0	XII - 6
	SC1MD1	x'03F9B'	R/W	Serial interface 1 mode register 1	XII - 7
	SC1MD2	x'03F9C'	R/W	Serial interface 1 mode register 2	XII - 8
	SC1STR	x'03F9D'	R	Serial interface 1 state register	XII - 9
	RXBUF1	x'03F98'	R	Serial interface 1 reception data buffer	XII - 5
	TXBUF1	x'03F99'	R/W	Serial interface 1 transmission data buffer	XII - 5
	SC1ODC	x'03F9E'	R/W	Serial interface 1 port control register	XII - 10
	SC1CKS	x'03F9F'	R/W	Serial interface 1 transfer clock selection register	XII - 10
	PSCMD	x'03F6F'	R/W	Prescaler control register	V - 6
	P3DIR	x'03F33'	R/W	Port 3 direction control register	IV - 23
	P3PLU	x'03F43'	R/W	Port 3 pull-up control register	IV - 23
	SC1ICR	x'03FF7'	R/W	Serial interface 1 interrupt control register	III - 35

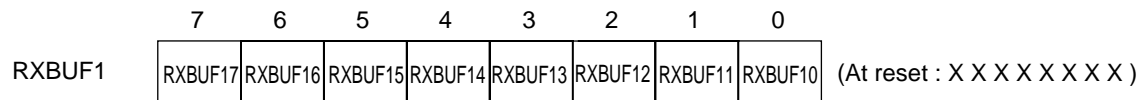
R/W : Readable / Writable

R : Readable only

## 12-2-2 Data Buffer Registers

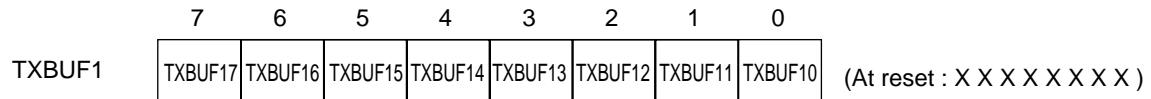
Serial Interface 1 has two 8-bit data buffer register for transmission, and for reception.

### ■ Serial Interface 1 Reception Data Buffer (RXBUF1)



**Figure 12-2-1 Serial Interface 1 Reception Data Buffer (RXBUF1 : x'03F98', R)**

### ■ Serial Interface 1 Transmission Data Buffer (TXBUF1)



**Figure 12-2-2 Serial Interface 1 Transmission Data Buffer (TXBUF1 : x'03F99', R/W)**

### 12-2-3 Mode Registers

#### Serial Interface 1 Mode Register 0 (SC1MD0)

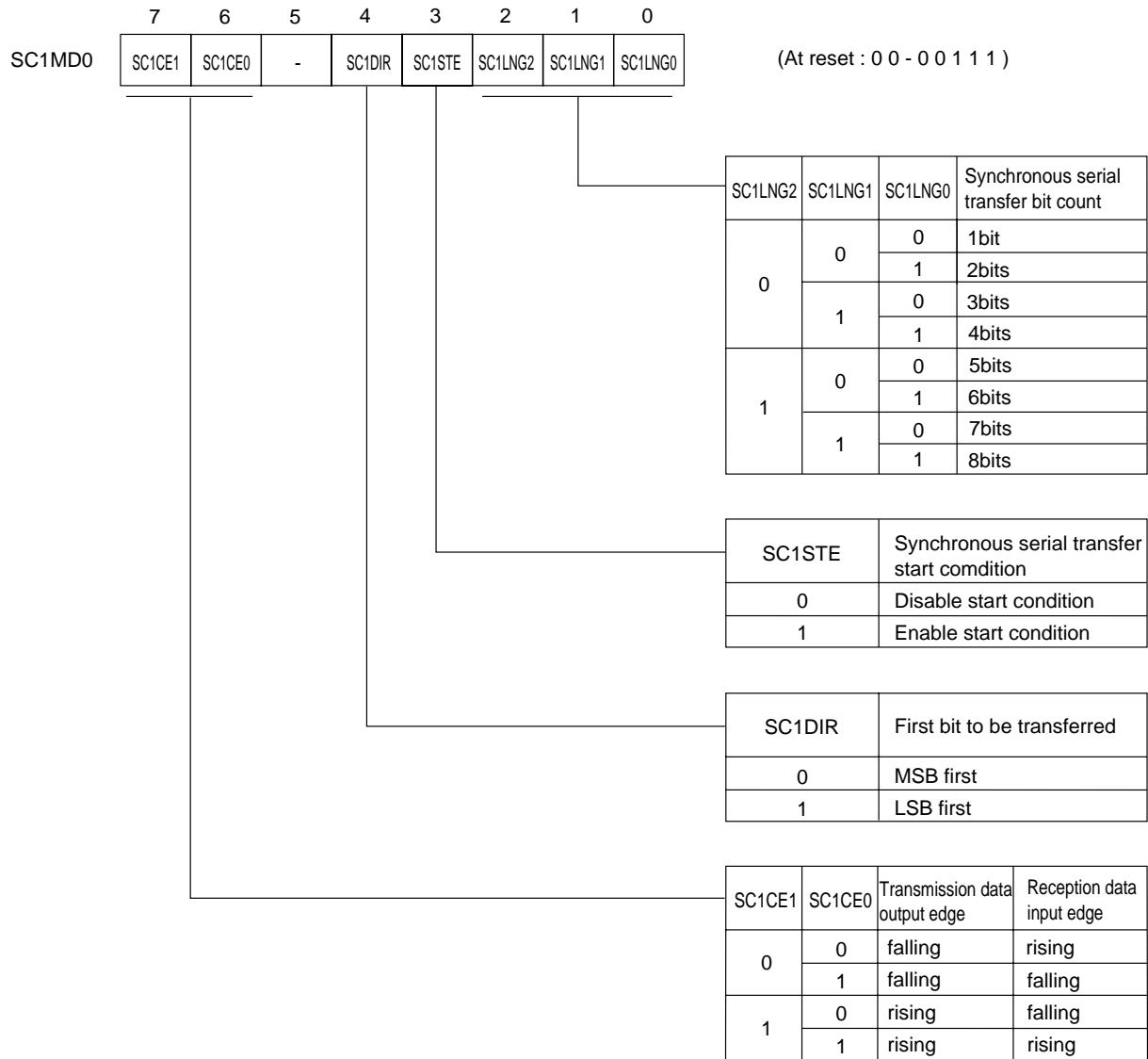


Figure 12-2-3 Serial Interface 1 Mode Register 0 (SC1MD0 : x'03F9A', R/W)



■Serial Interface 1 Mode Register 1 (SC1MD1)

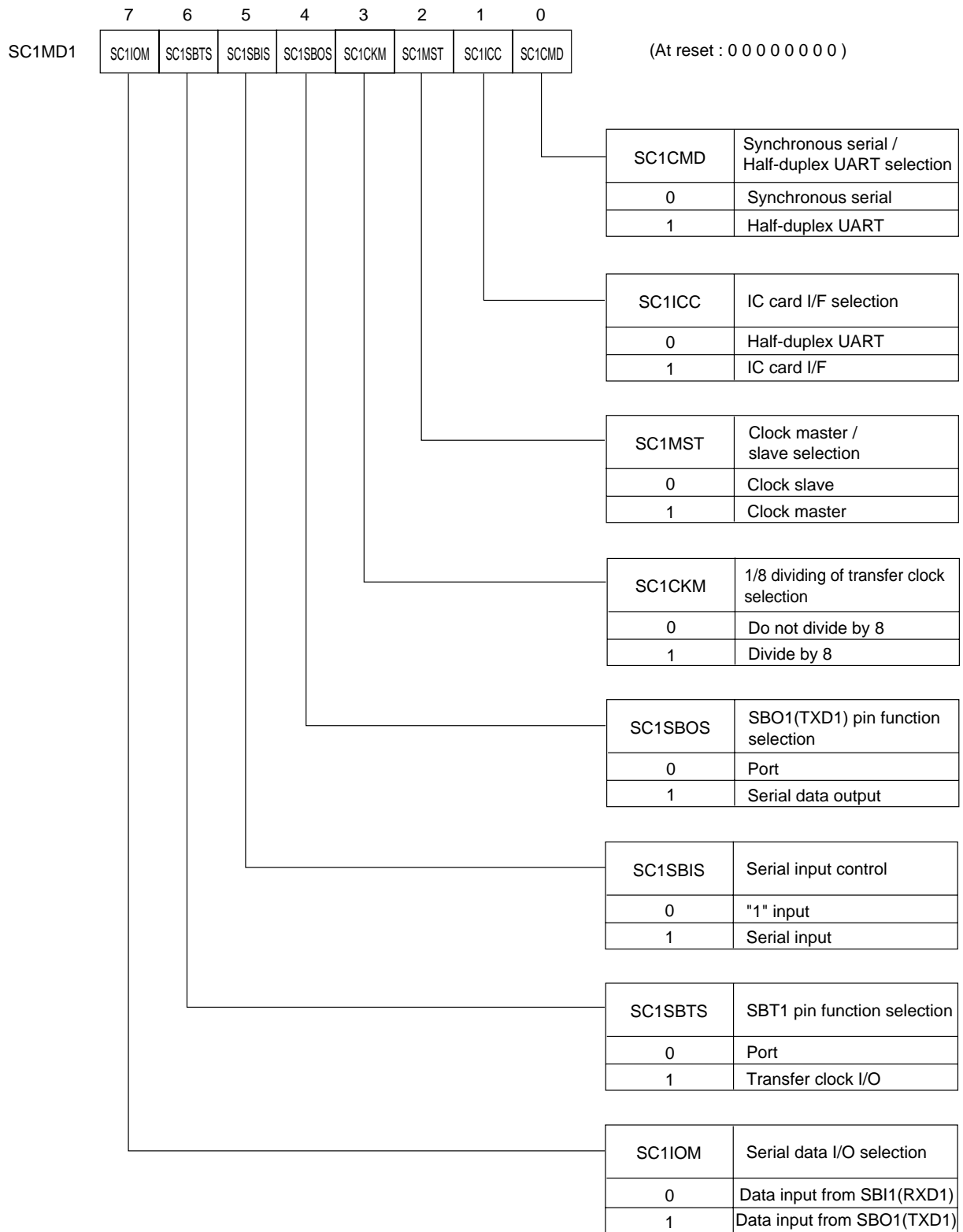


Figure 12-2-4 Serial Interface 1 Mode Register 1 (SC1MD1 : x'03F9B', R/W)

■Serial Interface 1 Mode Register 2 (SC1MD2)

SC1BRKF flag is only for reading.

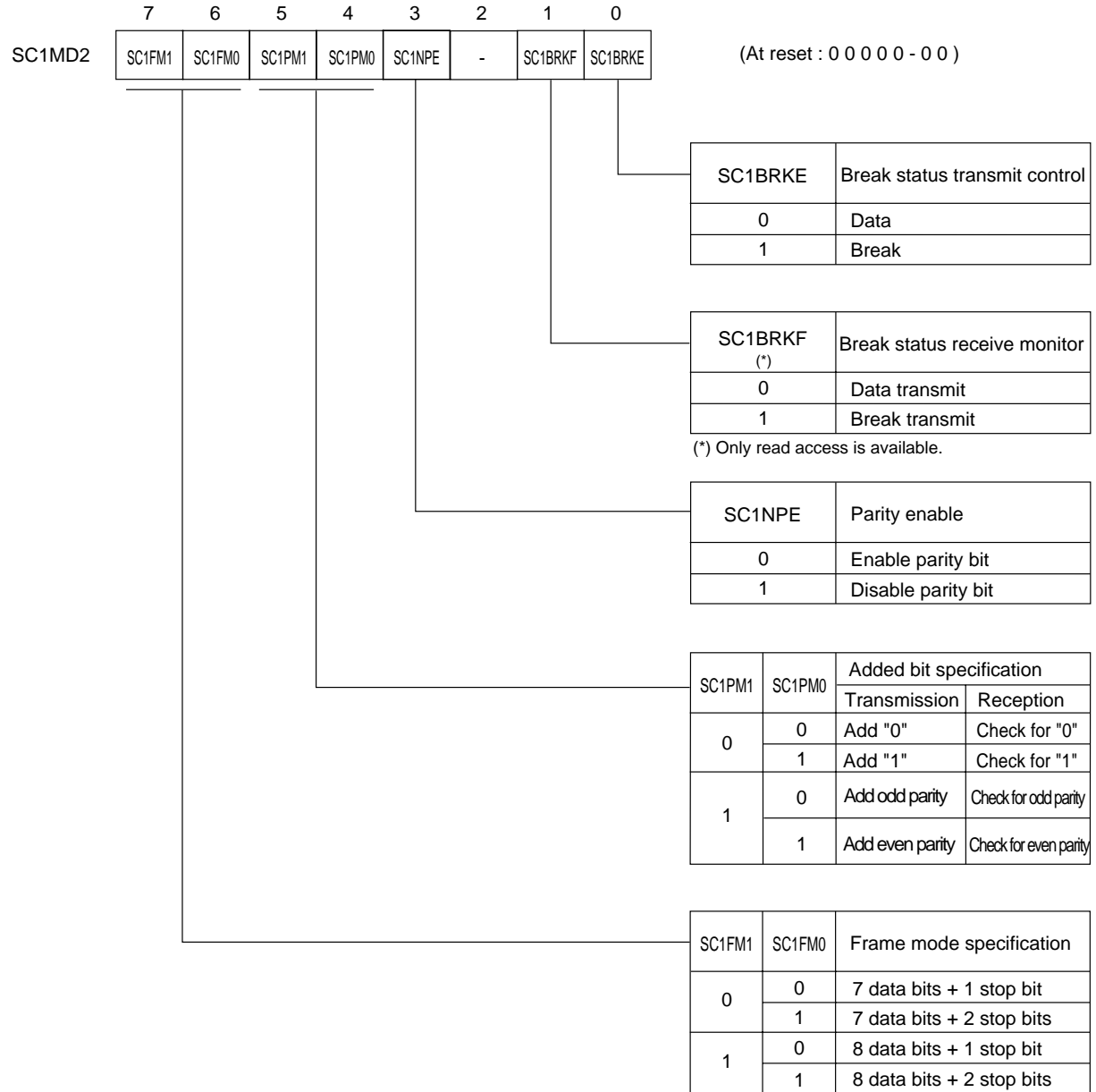


Figure 12-2-5 Serial Interface 1 Mode Register 2 (SC1MD2 : x'03F9C', R/W)

### ■ Serial Interface 1 State Register (SC1STR)

All flags are only for reading.

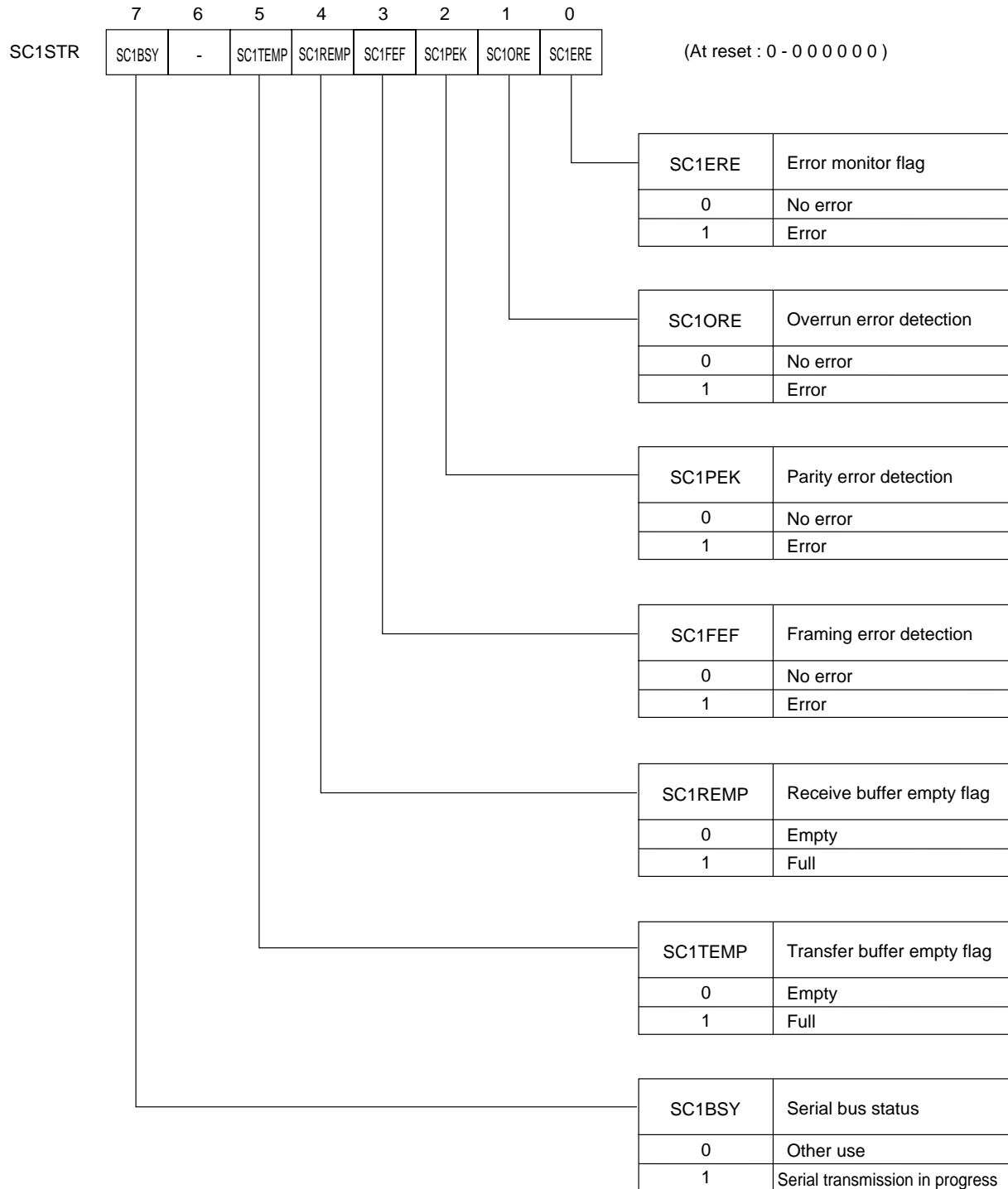


Figure 12-2-6 Serial Interface 1 State Register (SC1STR : x'03F9D', R)

■Serial Interface 1 Port Control Register (SC1ODC)

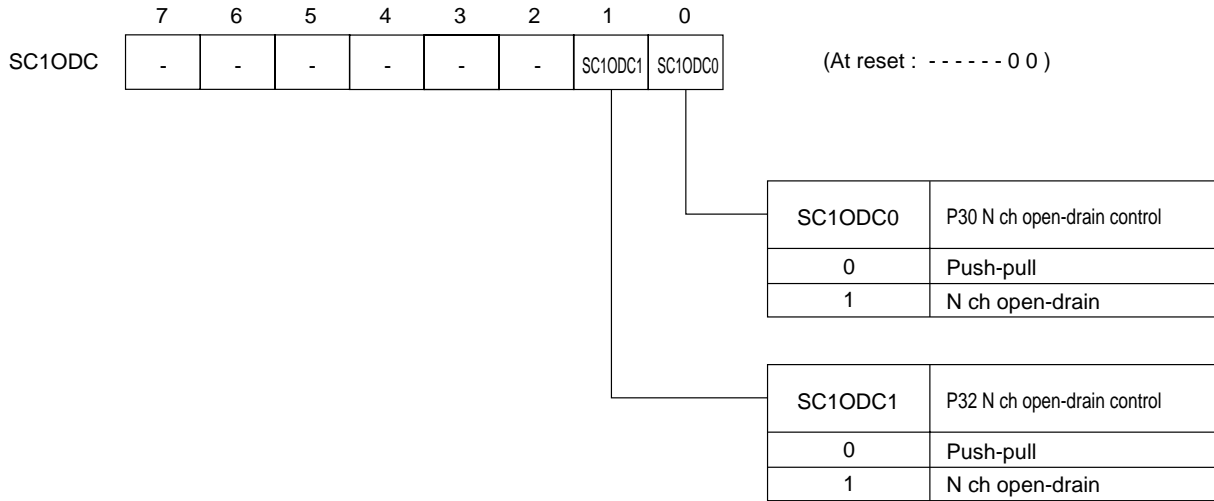


Figure 12-2-7 Serial Interface 1 Port Control Register (SC1ODC : x'03F9E', R/W)

■Serial Interface 1 Transfer Clock Selection Register (SC1CKS)

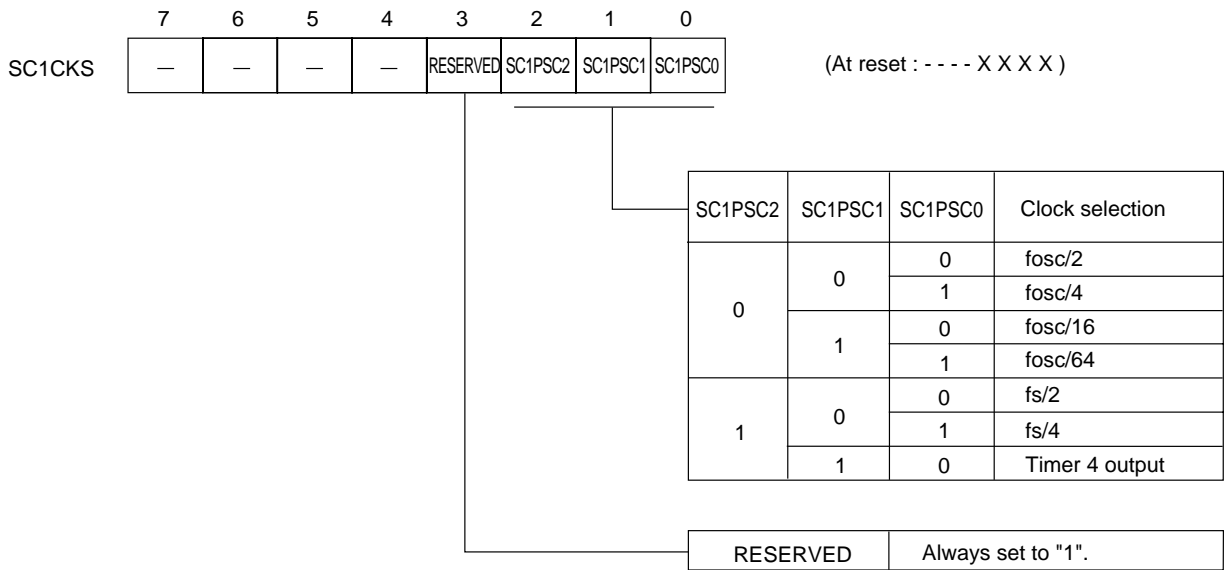


Figure 12-2-8 Serial Interface 1 Transfer Clock Selection Register (SC1CKS : x'03F9F', R/W)

## 12-3 Operation

Serial Interface 1 can be used for both clock synchronous and half-duplex UART.

### 12-3-1 Clock Synchronous Serial Interface

#### ■Activation Factor for Communication

Table 12-3-1 shows activation factors for communication. At master, the transfer clock is generated by setting data to the transmission data buffer TXBUF1, or by receiving a start condition. Except during communication, the input signal from SBT1 pin is masked to prevent errors by noise or so. This mask can be released automatically by setting a data to TXBUF1(access to the TXBUF1 register), or by inputting a start condition to the data input pin. Therefore, at slave, set data to TXBUF1, or input an external clock after a start condition is input. Just make sure that more than 2.5 transfer clocks after a start condition is input, is necessary before the external clock is input. This period is necessary for loading a data from TXBUF1 to the internal shift register.

**Table 12-3-1 Synchronous Serial Interface Activation Factor**

	Activation Factor	
	Transmission	Reception
Master communication	Set transmission data	Set dummy data
		Input start condition
Slave communication	Input clock after transmission data is set	Input clock after dummy data is set
		Input clock after start condition is input

#### ■Transfer Bit Count

The transfer bit count is selected from 1 bit to 8 bits. Set it by the SC1LNG 2 to 0 flag of the SC1MD0 register (at reset : 111). The SC1LNG 2 to 0 flag holds the former set value until it is set again.



Except during communication, SBT1 pin is masked to prevent errors by noise. At slave communication, set data to TXBUF1 or input a clock to SBT1 pin after a start condition is input.



Before an external clock is input, take more than 2.5 transfer clocks after setting data to TXBUF1. That is necessary for accurate communication.

■Start Condition Setup

The SC1STE flag of the SC1MD0 register sets if a start condition is enabled or not. If a start condition is enabled, and received at communication, a bit counter is cleared to restart the communication. The start condition is regarded when a data line (SBI1 pin (3 channels type) or SBO1 pin (2 channels type)) is changed from "H" to "L" as a clock line (SBT1 pin) is "H". Also, when the transmission and reception are operated at once, disable the start condition to accurate operation.

■First Transfer Bit Setup

The SC1DIR flag of the SC1MD0 register can set the first transfer bit. MSB first or LSB first can be selected.

■Transmission Data Buffer

The transmission data buffer, TXBUF1 is the reserve buffer that stores data to load the internal shift register. Data to be transferred should be set to the transmission data buffer, TXBUF1 load the internal shift register automatically. There should be 2.5 transfer-clocks period to load data. If data set to TXBUF1 twice during loading, the setup may not be done. By monitoring the transmission buffer empty flag SC1TEMP of SC1STR can determine if data is loading or not. If data is loading to TXBUF1, SC1TEMP flag is set to "1", and if data loading is finished, it is cleared to "0" automatically.

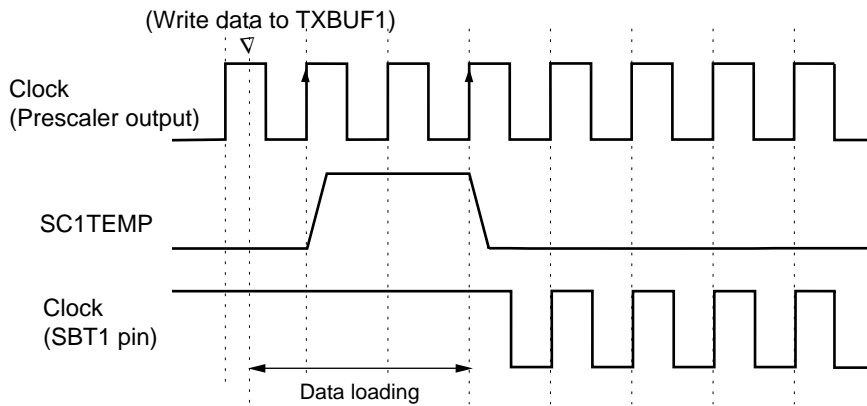
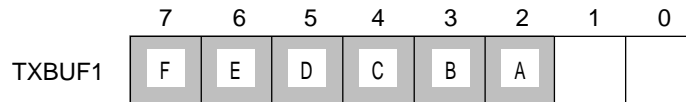


Figure 12-3-1 Data Loading Period and Transmission Buffer Empty Flag

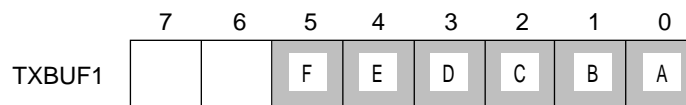
- At clock synchronous communication, transmission and reception should not be operated at once as "Enable start condition" is selected. The operation may be wrong.
- If a start condition is input to restart during communication, the transmission data is not valid. If the transmission should be operated again, set the transmission data to TXBUF1, again.
- RXBUF1 is rewritten in every communication complete. At sequence communication, data of RXBUF1 should be read till the next reception complete.

### ■Transfer Bit Count and First Transfer Bit

When the transfer bit is 1 bit to 7 bits at transmission, the data storing method to the transmission data buffer TXBUF1 is different, depending on the first transfer bit. At MSB first, use the upper bits of TXBUF1 for storing. When there are 6 bits to be transferred, as shown on figure 12-3-2-1, if data "A" to "F" are stored to bp2 to bp7 of TXBUF1, the transmission is operated from "F" to "A". At LSB first, use the lower bits of TXBUF1 for storing. When there are 6 bits to be transferred, as shown on figure 12-3-2-2, if data "A" to "F" are stored to bp0 to bp5 of TXBUF1, the transmission is operated from "A" to "F".



**Figure 12-3-2-1 Transfer Bit Count and First Transfer Bit (starting with MSB)**



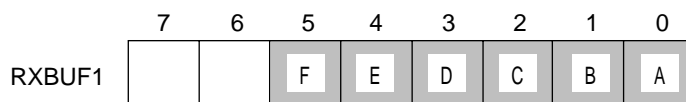
**Figure 12-3-2-2 Transfer Bit Count and First Transfer Bit (starting with LSB)**

### ■Received Data Buffer

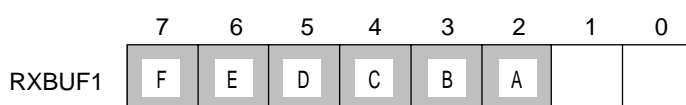
The received data buffer RXBIF1 is the sub-buffer that pushed the received data in the internal shift register. After the communication complete interrupt SC1IRQ is generated, data (regardless of transmission or received) stored in the internal shift register is stored to the received data buffer RXBUF1 automatically. RXBUF1 can store data up to 1 byte. RXBUF1 is rewritten in every communication complete, so read out data of RXBUF1 till the next receive complete. When the SC1SBIS flag of the SC1MD 1 register is set to "serial input", the received data buffer empty flag SC1REMP is set to "1" at the same time SC1IRQ is generated. SC1REMP is cleared to "0" after RXBUF1 is read.

### ■Receive Bit Count and First Transfer Bit

When the transfer bit count is 1 bit to 7 bits at reception, the data storing method to the received data buffer RXBUF1 is different depending on the first transfer bit selection. At MSB first, data are stored to the lower bits of RXBUF1. When there are 6 bits to be transferred, as shown on figure 12-3-3-1, if data "F" to "A" are stored to bp 0 to bp5 of RXBUF1. At LSB first, data are stored to the upper bits of RXBUF1. When there are 6 bits to be transferred, as shown on figure 12-3-3-2, if data "A" to "F" are stored to BP 2 to bp7 of RXBUF1.



**Figure 12-3-3-1 Receive Bit Count and Transfer First Bit (starting with MSB bit)**



**Figure 12-3-3-2 Receive Bit Count and Transfer First Bit (starting with LSB bit)**

■Sequence Communication

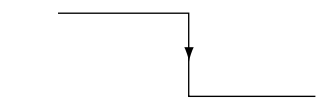
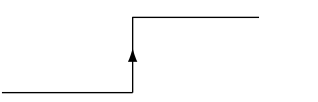
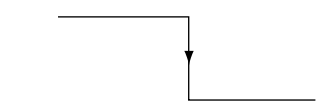
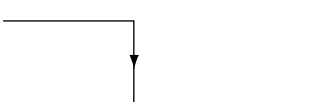
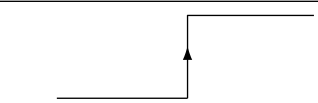
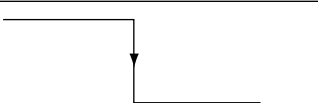
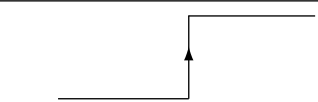
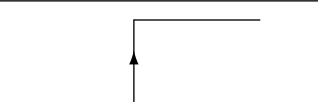
This serial interface has a function for sequence communication. If data is set to the transmission data buffer TXBUF1 during communication, the transmission buffer empty flag SC1TEMP is automatically set to communicate continuously. Data setup to TXBUF1 should be done till the communication complete interrupt SC1IRQ is generated after data is loaded to the internal shift register. At master communication, there is a suspension of communication for 3 transfer clocks till the next transmission clock is output after the SC1IRQ generation.

Also, the built-in automatic data transfer function ATC1 can activate. Data can be transferred continuously up to 255 bytes by ATC1 activation. In this case, there is a suspension of communication for up to 18 machine cycles + 3.5 transfer clocks. Refer to the transfer mode 8 to 9 in chapter 15, automatic transfer controller for ATC1 activation.

■Input Edge / Output Edge Setup

The SC1CE 1 to 0 flag of the SC1MD0 register set an output edge of the transmission data, an input edge of the received data. As the SC1CE1 flag = "0", the transmission data is output at the falling edge of SBT1, and as "1", output at the rising edge. As SC1CE0="0", the received data is received at the inversion edge to the output edge of transmission data, and as "1", stored at the same edge.

**Table 12-3-2 Transmission Data Output Edge and Received Data Input Edge**

SC1CE1	SC1CE0	Transmission data output edge	Received data input edge
0	0		
0	1		
1	0		
1	1		



### ■Clock Setup

The SC1CKS register (x'03F9F') selects a clock source from the special prescaler or timer 4 output. The special prescaler starts its operation after the PSCMD (x'03F6F') register selects "prescaler operation". The SC1MST flag of the SC1MD1 register can select the internal clock (clock master), or the external clock (clock slave). Even if the external clock is selected, set the internal clock that has the same clock cycle or below to the external clock, by the SC1CKS register. That is happened, because the interrupt flag SC1IRQ is generated by the internal clock. Here is the internal clock source that can be set by the SC1CKS register. Also, the SC1CKM flag of the SC1MD1 register can divide the internal clock by 8.

**Table 12-3-3 Synchronous Serial Interface Internal Clock Source**

	Serial interface 1
Clock source (Internal clock)	fosc/2
	fosc/4
	fosc/16
	fosc/64
	fs/2
	fs/4
	Timer 4 output

### ■Data Input Pin Setup

3 channels type (clock pin (SBT1 pin), data output pin (SBO1 pin), data input pin (SBI1 pin)) or 2 channels type (clock pin (SBT1 pin), data I/O pin (SBO1 pin)) can be selected as the communication. SBI1 pin can be used for only serial data input. SBO1 pin can select serial data input or output. The SC1IOM flag of the SC1MD1 register can select if the serial data is input to SBI1 pin or SBO1 pin. When "data input from SBO1 pin" is selected to set the 2 channels type, the P3DIR0 flag of the P3DIR register controls direction of SBO1 pin to switch transmission / reception. At that time, SBI1 pin is free to be used as a general port.



The transfer rate should be up to 2.5 MHz. If the transfer clock is over 2.5 MHz, the transmission data may not be sent correctly.



At reception, if SC1IOM of the SC1MD1 register is set to "1" and "serial data input from SBO1" is selected, SBI1 pin is used as a general port.

#### ■Received Buffer Empty Flag

When the communication complete interrupt SC1IRQ is generated, data is stored to RXBUF1 from the internal shift register, automatically. If data is stored to the shift register RXBUF1 leaving the SC1SBIS flag of the SC1MD1 register "serial input", the received buffer empty flag SC1REMP of the SC1STR register is set to "1". This indicates that the reception data is going to be read. SC1REMP is cleared to "0" by reading data in RXBUF1.

#### ■Transmission Buffer Empty Flag

If any data is set to TXBUF1 during communication (after loading data to the inside shift register before generating the communication complete interrupt SC1IRQ ), the transmission buffer empty flag SC1TEMP of the SC1STR register is set to "1". That indicates that the next transmission data is going to be transmitted. Data is loaded from the inside shift register to TXBUF1 by generation of SC1IRQ. The next transfer is started as SC1TEMP is cleared to "0".

#### ■Overrun Error and Error Monitor Flag

During reception, the next data has been already received before reading out of the data of the received data buffer RXBUF1, overrun error is generated and the SC1ORE flag of the SC1STR register is set to "1". And at the same time, the error monitor flag SC1ERE is set to indicate that something wrong on reception. The SC1ORE flag is cleared at the generation of the next communication complete interrupt SC1IRQ, after the data of RXBUF1 is read out. SC1ERE is cleared as SC1ORE flag is cleared. These error flags have nothing to do with communication operation.



If the overrun error flag (SC1ORE flag) should be cleared immediately, set both of the SC1SBIS flag and the SC1SBOS flag of the SC1MD1 register to "0". The serial function can be reset by switching P30, P31 pins from the serial pins to the general port pins.  
(When the communication has finished, all monitor flag is cleared)

#### ■BUSY Flag

When any data is set to TXBUF1 or start condition is enabled, the busy flag SC1BSY of the SC1STR register is set to "1", and cleared to "0" on the generation of the communication complete interrupt SC1IRQ. And, during communication SC1BSY is always set. If the transmission buffer empty flag SC1TEMP is cleared to "0" the communication complete interrupt SC1IRQ is generated, SC1BSY is cleared to "0".

### ■Emergency Reset

It is possible to shut down communication. For a forced reset, the SC1SBOS flag and the SC1SBIS flag of the SC1MD1 register should be set to "0" (SBO1 pin : port, input data : "1" input). At forced reset, the status registers (the SC1BRKF flag of the SC1MD2 register, all flags of the SC1STR register) are initialized as they are set at reset, but the control register holds the set value.

### ■Last Bit of Transfer Data

Table 12-3-4 shows the data output holding period of the last bit at transmission, and the minimum data input period of the last bit at reception. At slave, the inside clock should be set, because a little time is necessary to hold data at data transmission. After data output holding period of the last bit, "H" is output.

**Table 12-3-4 Last Bit Data Length of Transfer Data**

	The last bit data holding period at transmission	The last data input period at reception
At master	1 bit data length	1 bit data length (Minimum)
At slave	[1 bit data length of external clock x 1/2] + [Internal clock frequency x (1/2 to 1) ]	

### ■Other Control Flag Setup

Table 12-3-5 shows flags that are not used at clock synchronous communication. So, they are not needed to set or monitor.

**Table 12-3-5 Other Control Flag**

Register	Flag	Detail
SC1MD1	SC1ICC	UART /IC card I/F selection
SC1MD2	SC1BRKF	Brake status reception monitor
	SC1NPE	Parity is enabled
	SC1PM1 to 0	Added bit specification
	SC1FM1 to 0	Frame mode specification
SC1STR	SC1PEK	Parity error detection
	SC1FEF	Frame error detection

■ Transmission Timing

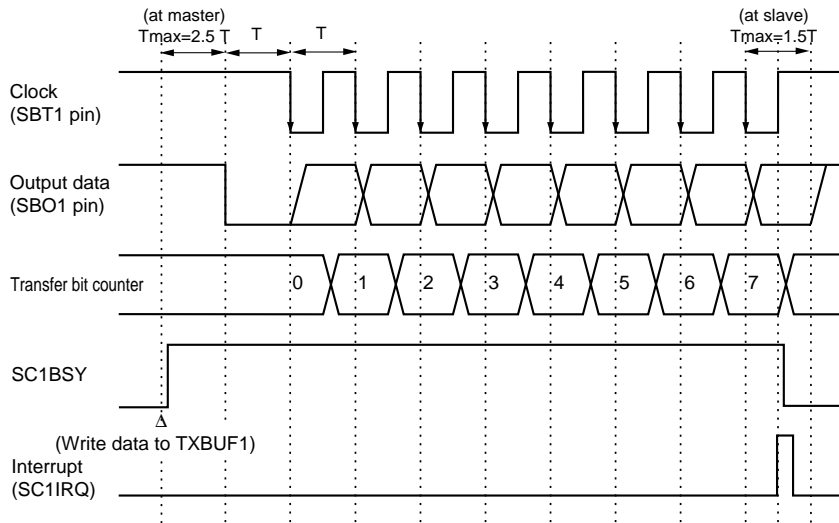


Figure 12-3-4 Transmission Timing (falling edge, start condition is enabled)

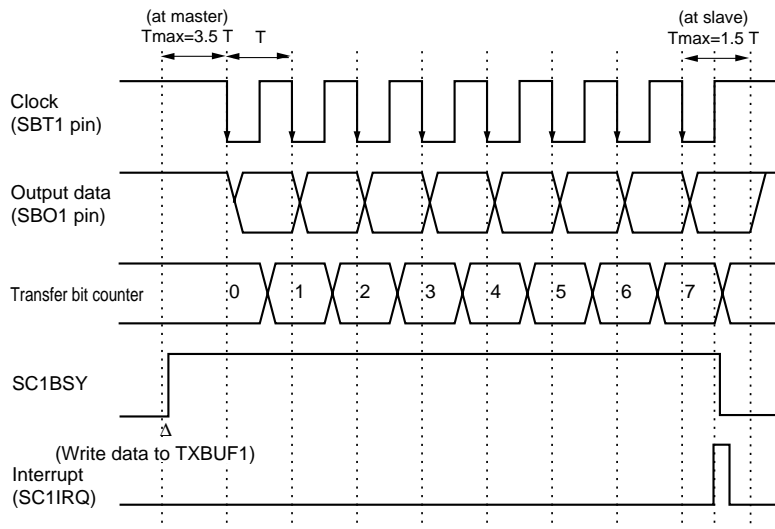


Figure 12-3-5 Transmission Timing (falling edge, start condition is disabled)

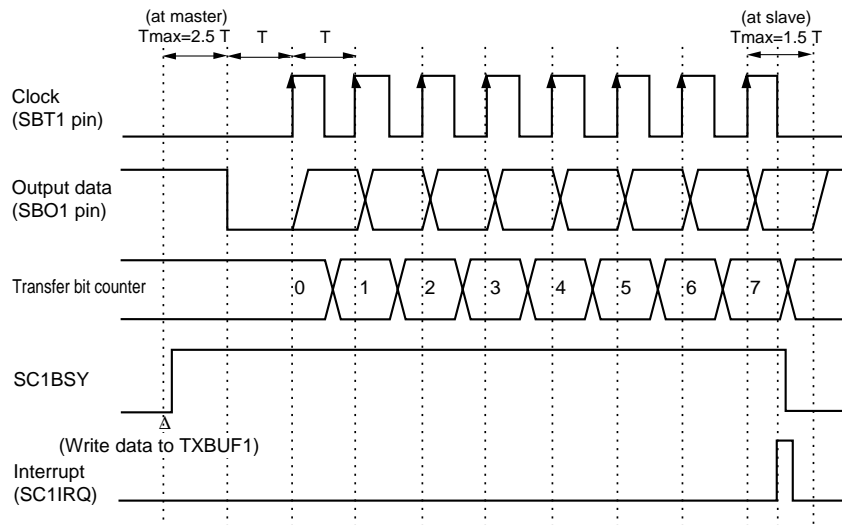


Figure 12-3-6 Transmission Timing (rising edge, start condition is enabled)

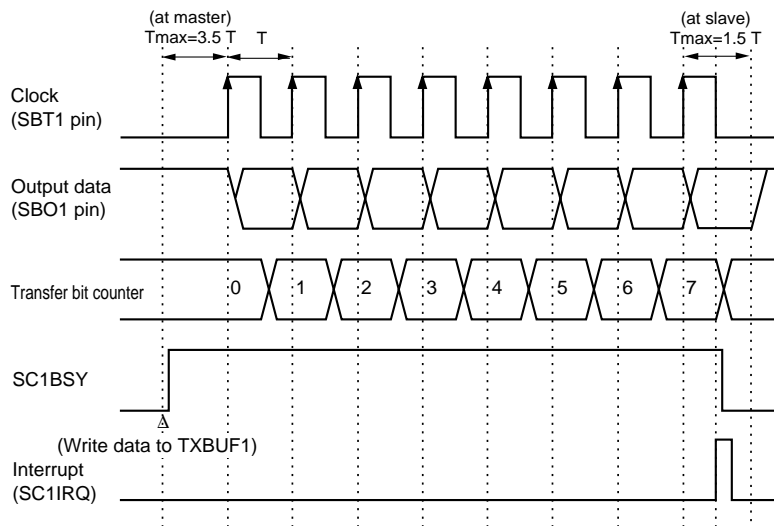


Figure 12-3-7 Transmission Timing (rising edge, start condition is disabled)

■ Reception Timing

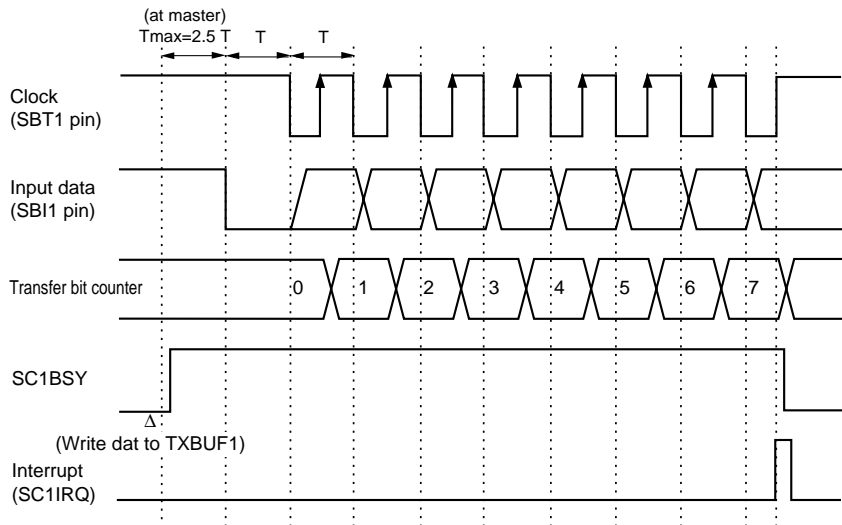


Figure 12-3-8 Reception Timing (rising edge, start condition is enabled)

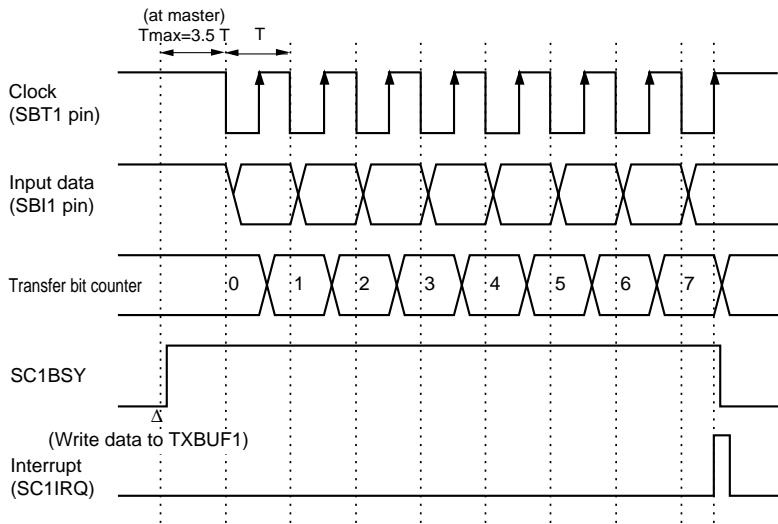
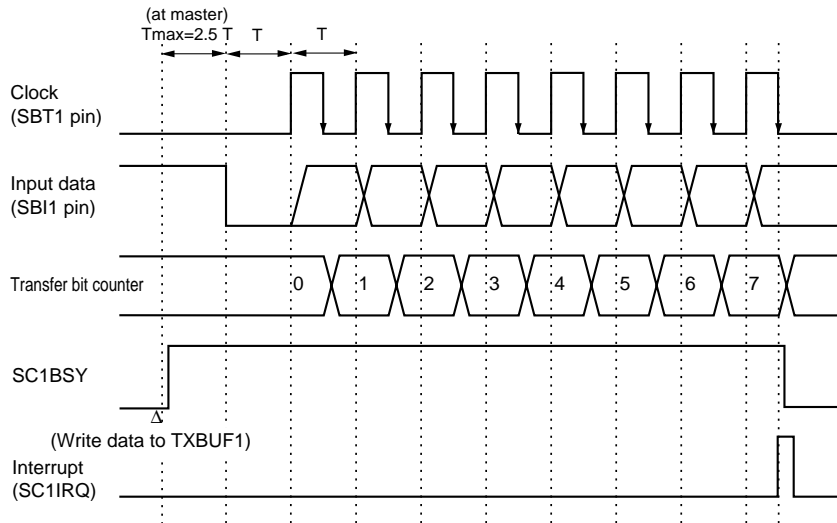
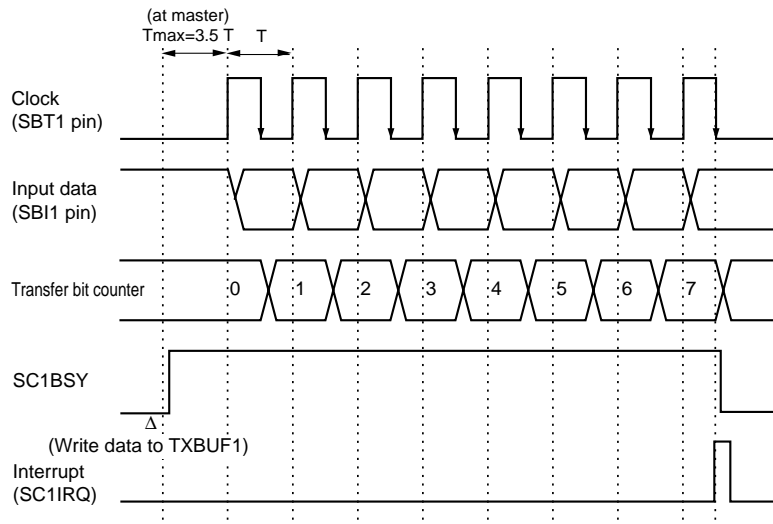


Figure 12-3-9 Reception Timing (rising edge, start condition is disabled)



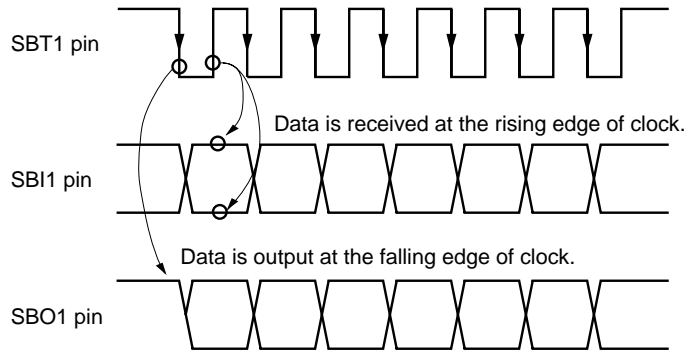
**Figure 12-3-10 Reception Timing (falling edge, start condition is enabled)**



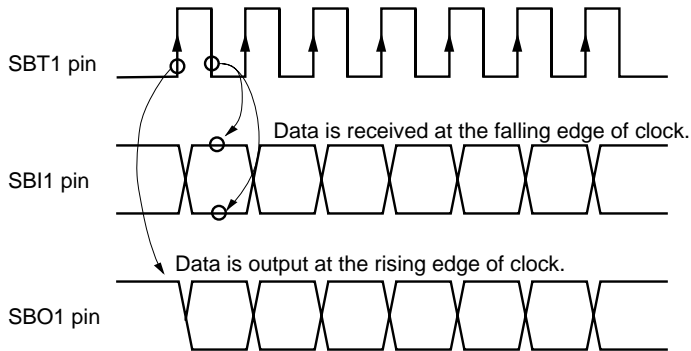
**Figure 12-3-11 Reception Timing (falling edge, start condition is disabled)**

■Transmission / Reception Timing

When transmission and reception are operated at the same time, set the SC1CE1 and SC1CE0 flag of the SC1MD0 register to "00" or "10". Data is received and transmitted at the opposite clock edge.



**Figure 12-3-12 Transmission / Reception Timing  
(Reception : rising edge, Transmission : falling edge)**



**Figure 12-3-13 Transmission / Reception Timing  
(Reception : falling edge, Transmission : rising edge)**



■ Pins Setup (3 channels, at transmission)

Table 12-3-6 shows the setup for synchronous serial interface pin for 3 channels (SBO1 pin, SBI1 pin, SBT1 pin) at transmission.

**Table 12-3-6 Setup for Synchronous Serial Interface Pin (3 channels, at transmission)**

Setup item	Data output pin	Data input pin	Clock I/O pin	
	SBO1 pin	SBI1 pin	SBT1 pin	
			Internal clock	External clock
Pin	P30	P31	P32	
SBI1/SBO1 pin	SBI1/SBO1 independent		-	
	SC1MD1(SC1IOM)			
Function	Serial data output	"1" input	Serial clock I/O	Serial clock I/O
	SC1MD1(SC1SBOS)	SC1MD1(SC1SBIS)	SC1MD1(SC1SBTS)	
Style	Push pull / Nch open-drain	-	Push pull / Nch open-drain	Push pull / Nch open-drain
	SC1ODC(SC1ODC0)		SC1ODC(SC1ODC1)	
I/O	Output mode	-	Output mode	Input mode
	P3DIR(P3DIR0)		P3DIR(P3DIR2)	
Pull-up	Added / Not added	-	Added / Not added	Added / Not added
	P3PLU(P3PLU0)		P3PLU(P3PLU2)	

■ Pins Setup (3 channels, at reception)

Table 12-3-7 shows the setup for synchronous serial interface pin for 3 channels (SBO1 pin, SBI1 pin, SBT1 pin).

**Table 12-3-7 Setup for Synchronous Serial Interface Pin (3 channels, at reception)**

Setup item	Data output pin	Data input pin	Clock I/O pin	
	SBO1 pin	SBI1 pin	SBT1 pin	
			Internal clock	External clock
Pin	P30	P31	P32	
SBI1/SBO1 pin	SBI1/SBO1 independent		-	
	SC1MD1(SC1IOM)			
Function	Port	Serial data input	Serial clock I/O	Serial clock I/O
	SC1MD1(SC1SBOS)	SC1MD1(SC1SBIS)	SC1MD1(SC1SBTS)	
Style	-	-	Push pull / Nch open-drain	Push pull / Nch open-drain
			SC1ODC(SC1ODC1)	
I/O	-	Input mode	Output mode	Input mode
		P3DIR(P3DIR1)	P3DIR(P3DIR2)	
Pull-up	-	-	Added / Not added	Added / Not added
			P3PLU(P3PLU2)	

■ Pins Setup (3 channels, at transmission / reception)

Table 12-3-8 shows the setup for synchronous serial interface pin for 3 channels (SBO1 pin, SBI1 pin, SBT1 pin) at transmission / reception.

**Table 12-3-8 Setup for Synchronous Serial Interface Pin  
(3 channels, at transmission / reception)**

Setup item	Data output pin	Data input pin	Clock I/O pin	
	SBO1 pin	SBI1 pin	SBT1 pin	
			Internal clock	External clock
Pin	P30	P31	P32	
SBI1/SBO1 pin	SBI1/SBO1 independent		-	
	SC1MD1(SC1IOM)			
Function	Serial data output	Serial data input	Serial clock I/O	Serial clock I/O
	SC1MD1(SC1SBOS)	SC1MD1(SC1SBIS)	SC1MD1(SC1SBTS)	
Style	Push pull / Nch open-drain	-	Push pull / Nch open-drain	Push pull / Nch open-drain
	SC1ODC(SC1ODC0)		SC1ODC(SC1ODC1)	
I/O	Output mode	Input mode	Output mode	Input mode
	P3DIR(P3DIR0)	P3DIR(P3DIR1)	P3DIR(P3DIR2)	
Pull-up	Added / Not added	-	Added / Not added	Added / Not added
	P3PLU(P3PLU0)		P3PLU(P3PLU2)	

■ Pins Setup (2 channels, at transmission)

Table 12-3-9 shows the setup for synchronous serial interface pin for 2 channels (SBO1 pin, SBT1 pin) at transmission. SBI1 pin can be used as a port.

**Table 12-3-9 Setup for Synchronous Serial Interface Pin (2 channels, at transmission)**

Setup item	Data I/O pin	Serial unused pin	Clock I/O pin	
	SBO1 pin	SBI1 pin	SBT1 pin	
			Internal clock	External clock
Pin	P30	P31	P32	
SBI1/SBO1 pin	SBI1/SBO1 connected		-	
	SC1MD1(SC1IOM)			
Function	Serial data output	"1" input	Serial clock I/O	Serial clock I/O
	SC1MD1(SC1SBOS)	SC1MD1(SC1SBIS)	SC1MD1(SC1SBTS)	
Style	Push pull / Nch open-drain	-	Push pull / Nch open-drain	Push pull / Nch open-drain
	SC1ODC(SC1ODC0)		SC1ODC(SC1ODC1)	
I/O	Output mode	-	Output mode	Input mode
	P3DIR(P3DIR0)		P3DIR(P3DIR2)	
Pull-up	Added / Not added	-	Added / Not added	Added / Not added
	P3PLU(P3PLU0)		P3PLU(P3PLU2)	

■ Pins Setup (2 channels, at reception)

Table 12-3-10 shows the setup for synchronous serial interface pin for 2 channels (SBO1 pin, SBT1 pin) at reception. SBI1 pin can be used as a port.

**Table 12-3-10 Setup for Synchronous Serial Interface Pin (2 channels, at reception)**

Setup item	Data I/O pin	Serial unused pin	Clock I/O pin	
	SBO1 pin	SBI1 pin	SBT1 pin	
			Internal clock	External clock
Pin	P30	P31	P32	
SBI1/SBO1 pin	SBI1/SBO1 connected		-	
	SC1MD1(SC1IOM)			
Function	Port	Serial data input	Serial clock I/O	Serial clock I/O
	SC1MD1(SC1SBOS)	SC1MD1(SC1SBIS)	SC1MD1(SC1SBTS)	
Style	-	-	Push-pull / Nch open-drain	Push-pull / Nch open-drain
	SC1ODC(SC1ODC1)			
I/O	Input mode	-	Output mode	Input mode
	P3DIR(P3DIR0)		P3DIR(P3DIR2)	
Pull-up	-	-	Added / Not added	Added / Not added
	P3PLU(P3PLU2)			

## 12-3-2 Setup Example

### ■Transmission / Reception Setup Example

The setup example for clock synchronous serial communication with serial interface 1 is shown. Table 12-3-11 shows the conditions at transmission / reception.


**Table 12-3-11 Setup Examples for Synchronous Serial Interface Transmission / Reception**

Setup item	set to	Setup item	set to
SBI1/SBO1 pin	Independent (with 3 channels)	Clock source	fs/2
Transfer bit count	8 bits	Clock source 1/8 dividing	not divided by 8
Start condition	none	SBT1/SBO1 pin style	N-ch open-drain
First transfer bit	MSB	SBT1 pin pull-up resistor	Added
Input clock edge	falling edge	SBO1 pin pull-up resistor	Added
Output clock edge	rising edge	Serial interface 1 communication complete interrupt	Enable
Clock	Internal clock		


An example setup procedure, with a description of each step is shown below.


Setup Procedure	Description
(1) Select the prescaler operation. PSCMD (x'3F6F') bp0 : PSCEN = 1	(1) Set the PSCEN flag of the PSCMD register to "1" to select "prescaler operation".
(2) Select the clock source. SC1CKS (x'3F9F') bp2-0 : SC1PSC2-0 = 100 bp3 = 1	(2) Set the SC1PSC2-0 flag of the SC1CKS register to "100" to select "fs/2" as a clock source . Set bp3 of the SC1CKS register to "1", always.
(3) Control the pin type. SC1ODC (x'3F9E') bp1-0 : SC1ODC1-0 = 11 P3PLU (x'3F43') bp2, 0 : P3PLU2, 0 = 1, 1	(3) Set the SC1ODC1-0 flag of the SC1ODC register to "11" to select "N-ch open drain" to the SBO1/SBT1 pin. Set the P3PLU2, 0 flag of the P3PLU register to "1, 1" to add pull-up resistor.
(4) Control the pin direction. P3DIR (x'3F33') bp2-0 : P3DIR2-0 = 101	(4) Set the P3DIR2-0 flag of the port 3 pin's direction control register (P3DIR) to "101" to set P30, P32 "output mode", and to set P31 "input mode".
(5) Set the SC1MD0 register. Select the transfer bit count. SC1MD0 (x'3F9A') bp2-0 : SC1LNG2-0 = 111	(5) Set the SC1LNG2-0 flag of the serial 1 mode register (SC1MD0) to "111" to set the transfer bit count "8 bits".


Setup Procedure	Description
Select the start condition. SC1MD0 (x'03F9A') bp3 : SC1STE = 0	Set the SC1STE flag of the SC1MD0 register to "0" to disable start condition.
Select the first bit to be transferred. SC1MD0 (x'03F9A') bp4 : SC1DIR = 0	Set the SC1DIR flag of the SC1MD0 register to "0" to set MSB as a transfer first bit.
Select the transfer edge. SC1MD0 (x'03F9A') bp6 : SC1CE0 = 0 bp7 : SC1CE1 = 1	Set the SC1CE1, 0 flag of the SC1MD0 register to "1,0" to set the transmission data output edge "rising" and the received data input edge "falling".
(6) Set the SC1MD2 register. Control the output data. SC1MD2 (x'03F9C') bp0 : SC1BRKE = 0	(6) Set the SC0BRKE flag of the SC1MD2 register to "0" to select "serial data communication".
Set other mode registers. SC1MD2 (x'03F9C') bp7-3	No need at synchronous serial communication.
(7) Set the SC1MD1 register. Select the communication type. SC1MD1 (x'03F9B') bp0 : SC1CMD = 0	(7) Set the SC1CMD flag of the SC1MD1 register to "0" to select "synchronous serial".
Select the transfer clock. SC1MD1 (x'03F9B') bp2 : SC1MST = 1 bp3 : SC1CKM = 0	Set the SC1MST flag of the SC1MD1 register to "1" to select clock master (inside clock). Set the SC1CKM flag to "1" to select "do not divide by 8" for source clock.
Control the pin function. SC1MD1 (x'03F9B') bp4 : SC1SBOS = 1 bp5 : SC1SBIS = 1 bp6 : SC1SBTS = 1 bp7 : SC1IOM = 0	Set the SC1SBOS, SC1SBIS, SC1SBTS flag of the SC1MD1 register to "1" to set SBO1 pin "serial data output", SBI1 pin "serial data input", and SBT1 pin "serial clock I/O". Set the SC1IOM flag "0" to set serial data input from SBI1 pin.
(8) Set the interrupt level. SC1ICR (x'03FF7') bp7-6 : SC1LV1-0 = 10	(8) Set the interrupt level by the SC1LV1-0 flag of the serial 1 interrupt control register (SC1ICR).


Setup Procedure	Description
<p>(9) Enable the interrupt.            SC1ICR (x'3FF7')            bp1 : SC1IE = 1</p> <p>(10) Start serial transmission.            Transmission data→TXBUF1 (x'3F99')            Received data→input to SBI1 pin.</p>	<p>(9) Set the SC1IE flag of the SC1ICR register to "1" to enable interrupts.            If any interrupt request flag (SC1IR of the SC1ICR register) has already been set, clear SC1IR before an interrupt is enabled.            [  Chapter 3 3-1-4. Interrupt Flag Setup ]</p> <p>(10) Set the transmission data to the serial communication data buffer TXBUF1. Then, an internal clock is generated to start transmission / reception. After communication has finished, serial 1 interrupt SC1IRQ is generated.</p>


Note : In (5) to (7), each settings can be set at once.

 When only reception with 3 channels is operated, set SC1SBOS of the SC1MD1 register to "0" and select a port. The SBO1 pin can be used as a general port.

 When SBO1 / SBI1 pin are connected for communication with 2 channels , the SBO1 pin inputs / outputs serial data. The port direction control register P3DIR switches I/O. At reception, set SC1SBIS of the SC1MD1 register to "1", always, to select "serial data input". The SBI1 pin can be used as a general port.

 It is possible to shut down communication. If the communication should be stopped by force, set SC1SBOS and SC1SBIS of the SC1MD1 register to "0".

 Each flag should be set as the procedure in order. Activation for communication should be operated after all control registers (except Table 12-2-1 : TXBUF1, RXBUF1) are set.

 Transfer rate of transfer clock that set by SC1CKS register should be under 2.5 MHz.

### 12-3-3 UART Serial Interface

Serial 1 can be used for half-duplex UART communication. Table 12-3-12 shows UART serial interface functions.

**Table 12-3-12 UART Serial Interface Functions**

Communication style	UART (half-duplex)
Interrupt	SC1IRQ (transmission, reception)
Pin	TXD1 (output, input) RXD1 (input)
Specification the first transfer bit	MSB / LSB
Selection of parity bit	√
Parity bit control	0 parity 1 parity odd parity even parity
Frame selection	7 bits + 1stop 7 bits + 2stops 8 bits + 1stop 8 bits + 2stops
Continuous operation	√
Continuous operation (with ATC1)	√
Maximum transfer rate	300 kbps (standard 300 bps to 38.4 kbps) (with baud rate timer (timer 4))

#### ■Activation Factor for Communication

At transmission, if any data is written to the transmission data buffer TXBUF1, a start condition is generated to start transfer. At reception, if a start condition is received, communication is started. At reception, if the "L" duration for start bit is longer than 0.5 transfer bit duration, that can be regarded as a start condition.

#### ■Transmission

Data transfer is automatically started by writing data to the transmission data buffer TXBUF1. During transmission, no reception, no input start condition available.

#### ■Reception

Once a start condition is received, reception is started after the transfer bit counter is cleared. If a start condition is received during communication, the transfer bit counter is cleared, then communication is automatically restarted. During reception, transfer is disabled.

#### ■Transfer Bit Count Setup

The transfer bit count is automatically set after the frame mode is specified by the SC1FM1 to 0 flag of the SC1MD2 register. If the SC1CMD flag of the SC1MD1 register is set to "1", and UART communication is selected, the setup by the synchronous serial data transfer bit count selection flag SC1LNG2 to 0 is no longer valid.

#### ■Input Edge / Output Edge Setup

The SC1CE1 to 0 flag of the SC1MD0 register sets an output edge of the transmission data and an input edge of the received data. At UART communication, a transfer clock is not needed, but to decide transmission / reception timing in this serial interface inside, the SC1CE1 to 0 flag is needed to be set. At UART communication, set the SC1CE1 to 0 flag always "00", and select the transmission data output edge "falling", the received data input edge "rising".

For more detail about setup for input edge / output edge, refer to Table 12-3-2 (XII-p14).

#### ■Data Input Pin Setup

The communication mode can be selected from with 2 channels (data output pin (TXD1 pin), data input pin (RXD1 pin)), or with 1 channel (data I/O pin TXD1 pin). The RXD1 pin can be used only for serial data input. The TXD1 pin can be used for serial data input or output. The SC1IOM flag of the SC1MD1 register can specify which pin, RXD1 or TXD1 to input the serial data. "Data input from TXD1 pin" is selected to be with 1 channel communication, transmission / reception is switched by controlling TXD1 pin's direction by the P3DIR 0 flag of the P3DIR register. At that time, the RXD1 pin can be used as a general port.

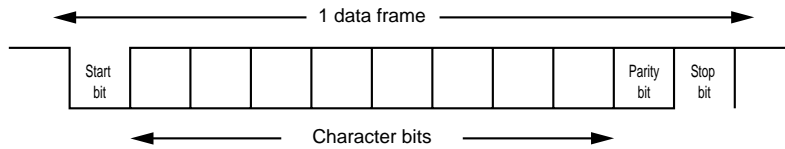


The SC1CE1 to 0 flag of the SC1MD0 register should be always "00", because the timing of data transmission / reception is decided at serial interface 1 inside.



■Frame Mode and Parity Check Setup

Figure 12-3-14 shows the data format at UART communication.



**Figure 12-3-14 UART Serial Interface Transmission / Reception Data Format**

The transmission / reception data consists of start bit, character bit, parity bit and stop bit. Table 12-3-13 shows its kinds to be set.

**Table 12-3-13 UART Serial Interface Transmission / Reception Data**

Start bit	1 bit
Character bit	7, 8 bits
Parity bit	0 fixed, 1 fixed, even, odd, none
Stop bit	1, 2 bits

The SC1FM1 to 0 flag of the SC1MD2 register sets the frame mode as shown in table 12-3-14. If the SC1CMD flag of the SC1MD1 register is set to "1", and UART communication is selected, the transfer bit count on the SC1LNG2 to 0 flag of the SC1MD0 register is no more valid.

**Table 12-3-14 UART Serial Interface Frame Mode**

SC1MD2 register		Frame mode
SC1FM1	SC1FM0	
0	0	Characterbit 7 bits + Stop bit 1 bit
0	1	Characterbit 7 bits + Stop bit 2 bits
1	0	Characterbit 8 bits + Stop bit 1 bit
1	1	Characterbit 8 bits + Stop bit 2 bits

Parity bit is to detect wrong bits with transmission / reception data.

Table 12-3-15 shows kinds of parity bit. The SC1NPE, SC1PM1 to 0 flag of the SC1MD2 register set parity bit.

**Table 12-3-15 Parity Bit of UART Serial Interface**


SC1MD2 register			Parity bit	Setup
SC1NPE	SC1PM1	SC1PM0		
0	0	0	Fixed to 0	Set parity bit to "0".
0	0	1	Fixed to 1	Set parity bit to "1".
0	1	0	Odd parity	Control the total number of "1" of parity bit and character bit should be odd.
0	1	1	Even parity	Control the total number of "1" of parity bit and character bit should be even.
1	-	-	none	Do not add parity bit.

**■Break Status Transmission Control Setup**

The SC1BRKE flag of the SC1MD2 register generates the break status. If SC1BRKE is set to "1" to select the break transmission, all bits from start bits to stop bits transfer "0".

**■Reception Error**

At reception , there are 3 types of error ; overrun error, parity error and framing error. Reception error can be determined by the SC1ORE, SC1PEK, SC1FEF flag of the SC1STR register. Even one of those errors is detected, the SC1ERE flag of the SC1STR register is set to "1". The SC1PEK, the SC1FEF flags are reception error flag are renewed at generation of the communication complete interrupt SC1IRQ. The SC1ORE flag is cleared when the next communication complete interrupt SC1IRQ is generated after data of RXBUF1 is read out. The judgement of the received error flag should be operated until the next communication has finished. The communication operation does not have any effect on those error flags. Table 12-3-16 shows the list of reception error source.



If the overrun error flag (SC1ORE flag) should be cleared immediately, set both of the SC1SBIS flag and the SC1SBOS flag of the SC1MD1 register to "0". The serial function can be reset by switching P30, P31 pins from the serial pins to the general port pins.  
(When the communication has finished, all monitor flags are cleared)

**Table 12-3-16 Reception Error Source of UART Serial Interface**

Flag	Error	Source of error	
SC1ORE	Overrun error	Next data is received before reading the receive buffer.	
SC1PEK	Parity error	At fixed to 0	Parity bit is "1"
		At fixed to 1	Parity bit is "0"
		Odd parity	The total of "1" of parity bit and character bit is even.
		Even parity	The total of "1" of parity bit and character bit is odd.
SC1FEF	Framing error	Stop bit is not detected.	

#### ■Judgement of Break Status Reception

Reception at break status can be judged. If all received data from start bit to stop bit is "0", the SC1BRKF flag of the SC1MD2 register is set and regard the break status. The SC1BRKF flag is set at generation of the reception complete interrupt SC1IRQ.

#### ■Sequence Communication

It is possible to transfer continuously. If data is set to the transmission data buffer TXBUF1 during communication, the transmission buffer empty flag SC1TEMP is set to continue the communication, automatically. In this case, there is no pause on communication. Data should be set to TXBUF1 after data is loaded to the inside shift register before the communication complete interrupt SC1IRQ is generated.

Also, this LSI has an automatic data transfer function ATC1 that can be one of an activation factor. At activation by ATC1, data can be transferred up to 255 bytes, continuously. In this case, there is a communication blank ; up to 18 machine cycles + 3.5 bit data duration. For an activation by ATC1, refer to chapter 15. Automatic transfer controller, transfer mode 8 to 9.

#### ■Other Control Flag

Table 12-3-17 shows the other control flags that are not used at UART communication. So, they are not needed to be set.

**Table 12-3-17 Other Control Flag**

Symbol	Flag	Selection
SC1MD0	SC1LNG2 to 0	Transfer bit count
SC1MD1	SC1MST	Clock master / slave
	SC1SBTS	SBT pin function

The following items are same to synchronous serial interface.  
Reference as follows ;

■First Transfer Bit Setup

Refer to : XII-12

■Transmission Data Buffer

Refer to : XII-12

■Transfer Bit Count and First Transfer Bit

Refer to : XII-13

■Received Data Buffer

Refer to : XII-13

■Receive Bit Count and First Transfer Bit

Refer to : XII-13

■Received Buffer Empty Flag

Refer to : XII-16

■Transmission Buffer Empty Flag

Refer to : XII-16

■BUSY Flag

Refer to : XII-16

■Emergency Reset

Refer to : XII-16

■ Transmission Timing

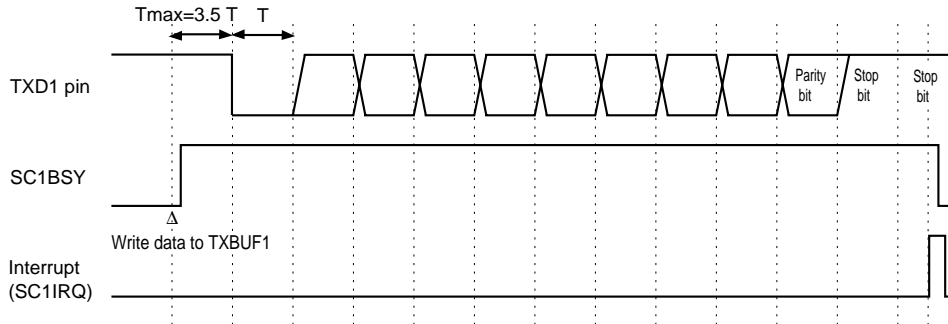


Figure 12-3-15 Transmission Timing (parity bit is enabled)

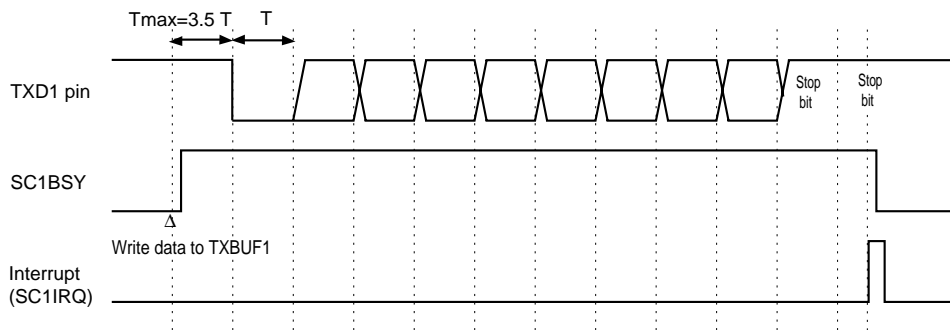


Figure 12-3-16 Transmission Timing (parity bit is disabled)

■ Reception Timing

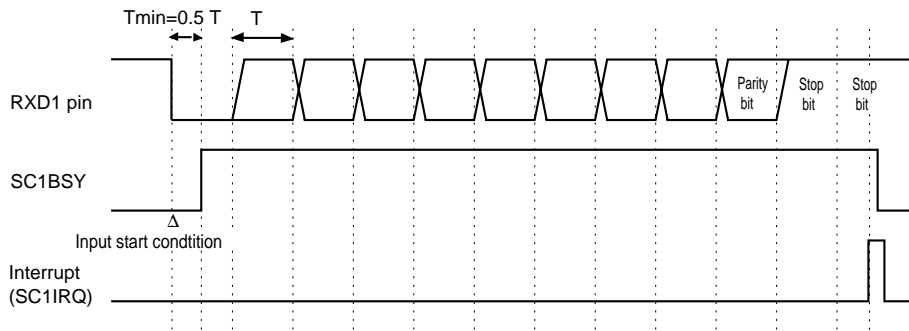


Figure 12-3-17 Reception Timing (parity bit is enabled)

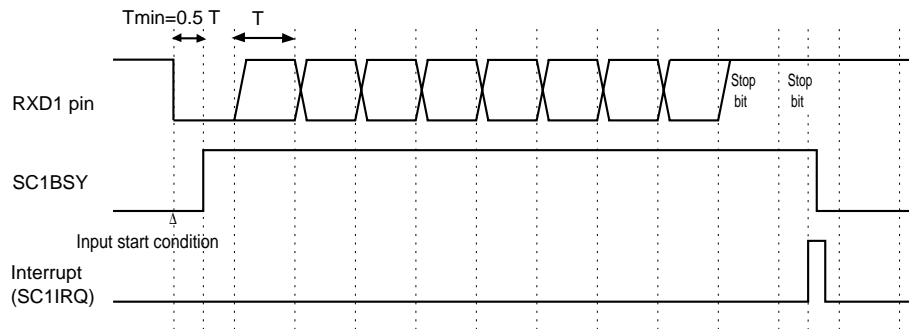


Figure 12-3-18 Reception Timing (parity bit is disabled)

### ■ Transfer Rate

Baud rate timer (timer 4) can set any transfer rate.

Table 12-3-18 shows the setup example of the transfer rate. For detail of the baud rate timer setup, refer to chapter 6. 6-8 serial transfer clock output operation.

**Table 12-3-18 UART Serial Interface Transfer Rate Setup Register**

Setup	Register	Page
Serial 1 clock source (Timer 4 output)	SC1CKS	XII - 10
Timer 4 clock source	TM4MD	VI - 15
Timer 4 compare register	TM4OC	VI - 9

Timer 4 compare register is set as follows ;

$$\text{overflow cycle} = (\text{set value of compare register} + 1) \times \text{timer clock cycle}$$

$$\text{baud rate} = 1 / (\text{overflow cycle} \times 2 \times 8) \text{ ("8" means that clock source is divided by 8)}$$

therefore,

$$\text{set value of compare register} = \text{timer clock frequency} / (\text{baud rate} \times 2 \times 8) - 1$$

For example, if baud rate should be 300 bps at timer 4 clock source  $f_s/4$  ( $f_{osc} = 8 \text{ MHz}$ ,  $f_s = f_{osc}/2$ ), set value should be as follows ;

$$\begin{aligned} \text{Set value of compare register} &= (8 \times 10^6 / 2 / 4) / (300 \times 2 \times 8) - 1 \\ &= 207 \\ &= \text{x'CF'} \end{aligned}$$

Timer 4 clock source and the set values of timer 4 compare register at the standard transfer rate are shown on the following page.



Transfer rate should be selected under 300 kbps.



At UART communication, the SC1CKM flag of the SC1MD1 register should be set to "1" to select "divided by 8".

**Table 12-3-19-1 UART Serial Interface Transfer Rate (decimal)**

		Transfer Rate (bps)									
fosc (MHz)	Clock source (timer)	300		960		1200		2400		4800	
		Set Value	Calculated Value	Set Value	Calculated Value	Set Value	Calculated Value	Set Value	Calculated Value	Set Value	Calculated Value
4.00	fosc	-	-	-	-	207	1202	103	2404	51	4808
	fosc/4	207	300	64	962	51	1202	25	2404	12	4808
	fosc/16	51	300	-	-	12	1202	-	-	-	-
	fosc/32	25	300	-	-	-	-	-	-	-	-
	fosc/64	12	300	-	-	-	-	-	-	-	-
	fs/2	207	300	64	962	51	1202	25	2404	12	4808
4.19	fs/4	104	297	-	-	25	1202	12	2404	-	-
	fosc	-	-	-	-	217	1201	108	2403	54	4761
	fosc/4	217	300	67	963	-	-	-	-	-	-
	fosc/16	-	-	16	963	-	-	6	2338	-	-
	fosc/32	-	-	-	-	-	-	-	-	-	-
	fosc/64	-	-	-	-	-	-	-	-	-	-
8.00	fs/2	217	300	67	963	-	-	-	-	-	-
	fs/4	108	300	33	963	-	-	13	2338	-	-
	fosc	-	-	-	-	-	-	207	2404	103	4808
	fosc/4	-	-	129	962	103	1202	51	2404	25	4808
	fosc/16	103	300	-	-	25	1202	12	2404	-	-
	fosc/32	51	300	-	-	12	1202	-	-	-	-
8.38	fosc/64	25	300	-	-	-	-	-	-	-	-
	fs/2	-	-	129	962	103	1202	51	2404	25	4808
	fs/4	207	300	64	962	51	1202	25	2404	12	4808
	fosc	-	-	-	-	-	-	217	2403	108	4805
	fosc/4	-	-	135	963	108	1201	-	-	-	-
	fosc/16	108	300	33	963	-	-	13	2338	-	-
12.00	fosc/32	-	-	16	963	-	-	6	2338	-	-
	fosc/64	-	-	-	-	-	-	-	-	-	-
	fs/2	-	-	135	963	108	1201	-	-	-	-
	fs/4	217	300	67	963	-	-	-	-	-	-
	fosc	-	-	-	-	-	-	-	-	155	4808
	fosc/4	-	-	194	962	155	1202	77	2404	38	4808
16.00	fosc/16	155	300	-	-	38	1202	-	-	-	-
	fosc/32	77	300	-	-	-	-	-	-	-	-
	fosc/64	38	300	-	-	-	-	-	-	-	-
	fs/2	-	-	194	962	155	1202	77	2404	38	4808
	fs/4	-	-	-	-	77	1202	38	2404	-	-
	fosc	-	-	-	-	-	-	-	-	207	4808
16.76	fosc/4	-	-	-	-	207	1202	103	2404	51	4808
	fosc/16	207	300	64	962	51	1202	25	2404	12	4808
	fosc/32	103	300	-	-	25	1202	12	2404	-	-
	fosc/64	51	300	-	-	12	1202	-	-	-	-
	fs/2	-	-	-	-	207	1202	103	2404	51	4808
	fs/4	-	-	129	962	103	1202	51	2404	25	4808
20.00	fosc	-	-	-	-	-	-	-	-	-	-
	fosc/4	-	-	-	-	217	1201	108	2403	54	4761
	fosc/16	217	300	67	963	-	-	-	-	-	-
	fosc/32	108	300	33	963	-	-	-	-	-	-
	fosc/64	-	-	16	963	-	-	-	-	-	-
	fs/2	-	-	-	-	217	1201	108	2403	54	4761
20.00	fs/4	-	-	135	963	108	1201	54	2381	-	-
	fosc	-	-	-	-	-	-	-	-	-	-
	fosc/4	-	-	-	-	-	-	129	2404	64	4808
	fosc/16	-	-	-	-	64	1202	-	-	-	-
	fosc/32	129	300	-	-	-	-	-	-	-	-
	fosc/64	64	300	-	-	-	-	-	-	-	-
20.00	fs/2	-	-	-	-	-	-	129	2404	64	4808
	fs/4	-	-	162	959	129	1202	64	2404	-	-



**Table 12-3-19-2 UART Serial Interface Transfer Rate (decimal)**

fosc (MHz)	Clock source (timer)	Transfer Rate (bps)									
		9600		19200		28800		31250		38400	
		Set Value	Calculated Value	Set Value	Calculated Value	Set Value	Calculated Value	Set Value	Calculated Value	Set Value	Calculated Value
4.00	fosc	25	9615	12	19231	-	-	7	31250	-	-
	fosc/4	-	-	-	-	-	-	1	31250	-	-
	fosc/16	-	-	-	-	-	-	-	-	-	-
	fosc/32	-	-	-	-	-	-	-	-	-	-
	fosc/64	-	-	-	-	-	-	-	-	-	-
	fs/2	-	-	-	-	-	-	1	31250	-	-
	fs/4	-	-	-	-	-	-	-	-	-	-
4.19	fosc	26	9699	-	-	-	-	-	-	-	-
	fosc/4	-	-	-	-	-	-	-	-	-	-
	fosc/16	-	-	-	-	-	-	-	-	-	-
	fosc/32	-	-	-	-	-	-	-	-	-	-
	fosc/64	-	-	-	-	-	-	-	-	-	-
	fs/2	-	-	-	-	-	-	-	-	-	-
	fs/4	-	-	-	-	-	-	-	-	-	-
8.00	fosc	51	9615	25	19231	-	-	15	31250	12	38462
	fosc/4	12	9615	-	-	-	-	3	31250	-	-
	fosc/16	-	-	-	-	-	-	-	-	-	-
	fosc/32	-	-	-	-	-	-	-	-	-	-
	fosc/64	-	-	-	-	-	-	-	-	-	-
	fs/2	12	9615	-	-	-	-	3	31250	-	-
	fs/4	-	-	-	-	-	-	1	31250	-	-
8.38	fosc	54	9523	26	19398	-	-	-	-	-	-
	fosc/4	-	-	-	-	-	-	-	-	-	-
	fosc/16	-	-	-	-	-	-	-	-	-	-
	fosc/32	-	-	-	-	-	-	-	-	-	-
	fosc/64	-	-	-	-	-	-	-	-	-	-
	fs/2	-	-	-	-	-	-	-	-	-	-
	fs/4	-	-	-	-	-	-	-	-	-	-
12.00	fosc	77	9615	38	19231	25	28846	23	31250	-	-
	fosc/4	-	-	-	-	-	-	5	31250	-	-
	fosc/16	-	-	-	-	-	-	-	-	-	-
	fosc/32	-	-	-	-	-	-	-	-	-	-
	fosc/64	-	-	-	-	-	-	-	-	-	-
	fs/2	-	-	-	-	-	-	5	31250	-	-
	fs/4	-	-	-	-	-	-	2	31250	-	-
16.00	fosc	103	9615	51	19231	-	-	31	31250	25	38462
	fosc/4	25	9615	12	19231	-	-	7	31250	-	-
	fosc/16	-	-	-	-	-	-	-	-	-	-
	fosc/32	-	-	-	-	-	-	-	-	-	-
	fosc/64	-	-	-	-	-	-	-	-	-	-
	fs/2	25	9615	-	-	-	-	7	31250	-	-
	fs/4	12	9615	-	-	-	-	3	31250	-	-
16.76	fosc	108	9610	54	19045	-	-	-	-	-	-
	fosc/4	26	9699	-	-	-	-	-	-	-	-
	fosc/16	-	-	-	-	-	-	-	-	-	-
	fosc/32	-	-	-	-	-	-	-	-	-	-
	fosc/64	-	-	-	-	-	-	-	-	-	-
	fs/2	26	9699	-	-	-	-	-	-	-	-
	fs/4	-	-	-	-	-	-	-	-	-	-
20.00	fosc	129	9615	64	19231	-	-	39	31250	-	-
	fosc/4	-	-	-	-	-	-	9	31250	-	-
	fosc/16	-	-	-	-	-	-	-	-	-	-
	fosc/32	-	-	-	-	-	-	-	-	-	-
	fosc/64	-	-	-	-	-	-	-	-	-	-
	fs/2	-	-	-	-	-	-	9	31250	-	-
	fs/4	-	-	-	-	-	-	4	31250	-	-

■Pin Setup (1, 2 channels, at transmission)

Table 12-3-20 shows the pins setup at UART serial interface transmission. The pins setup is common to the TXD1 pin, RXD1 pin, regardless of RXD1 pin is independent / connected.

**Table 12-3-20 UART Serial Interface Pin Setup (1, 2 channels, at transmission)**

Setup item	Data output pin	Data input pin
	TXD1 pin	RXD1 pin
Pin	P30	P31
TXD1/RXD1 pin	TXD1/RXD1 pin independent / connected	
	SC1MD1(SC1IOM)	
Function	Serial data output	"1" input
	SC1MD1(SC1SBOS)	SC1MD1(SC1SBIS)
Style	Push-pull / N-ch open-drain	-
	SC1ODC(SC1ODC0)	
I/O	Output mode	-
	P3DIR(P3DIR0)	
Pull-up	Added / Not added	-
	P3PLU(P3PLU0)	

■Pin Setup (2 channels, at reception)

Table 12-3-21 shows the pins setup at UART serial interface reception for 2 channels (TXD1 pin, RXD1 pin).

**Table 12-3-21 UART Serial Interface Pin Setup (2 channels, at reception)**

Setup item	Data output pin	Data input pin
	TXD1 pin	RXD1 pin
Pin	P30	P31
TXD1/RXD1 pin	TXD1/RXD1 pin independent	
	SC1MD1(SC1IOM)	
Function	Port	Serial data input
	SC1MD1(SC1SBOS)	SC1MD1(SC1SBIS)
Style	-	-
I/O	-	Input mode
	-	P3DIR(P3DIR1)
Pull-up	-	-

■ Pin Setup (1 channel, at reception)

Table 12-3-22 shows the pin setup at UART serial interface reception for 1 channel (TXD1 pin). The RXD1 pin is not used, so can be used as a port.

**Table 12-3-22 UART Serial Interface Pin Setup (1 channel, at reception)**

Setup item	Data output pin	Serial unused pin
	TXD1 pin	RXD1 pin
Pin	P30	P31
TXD1/RXD1 pin	TXD1/RXD1 pin connected	
	SC1MD1(SC1IOM)	
Function	Port	Serial data input
	SC1MD1(SC1SBOS)	SC1MD1(SC1SBIS)
Style	-	-
I/O	Input	-
	P3DIR(P3DIR0)	-
Pull-up	-	-

### 12-3-4 Setup Example

■Transmission Setup

The setup example at UART transmission with serial interface 1 is shown.


Table 12-3-23 shows the conditions at transmission.


**Table 12-3-23 UART Interface Transmission Setup**

Setup item	set to
TXD1/RXD1 pin	Connection (with 1 line)
Frame mode	8bits + 2 stop bit
First transfer bit	MSB
Clock source	Timer 4 output
Type of TXD1 pin	N-ch open-drain
Pull-up resistor of TXD1 pin	added
Parity bit add / check	"0" add / check
Serial interface 1 communication complete interrupt	Enable


An example setup procedure, with a description of each step is shown below.


Setup Procedure	Description
(1) Select prescaler operation. PSCMD (x'3F6F') bp0 : PSCEN = 1	(1) Set the PSCEN flag of the PSCMD register to "1" to select prescaler operation.
(2) Select the clock source. SC1CKS (x'3F9F') bp2-0 : SC1PSC2-0 = 110 bp3 = 1	(2) Set the SC1PSC2-0 flag of the SC1CKS register to "110" to select timer 4 output as a clock source. Set bp3 of the SC1CKS register to "1", always.
(3) Control the pin type. SC1ODC (x'3F9E') bp0 : SC1ODC0 = 1 P3PLU (x'3F43') bp0 : P3PLU0 = 1	(3) Set the SC1ODC0 flag of the SC1ODC register to "1" to select N-ch open drain for the TXD1 pin. Set the P3PLU0 flag of the P3PLU register to "1" to add pull-up resistor.
(4) Control the pin direction. P3DIR (x'3F33') bp0 : P3DIR0 = 1	(4) Set the P3DIR0 flag of the port 3 pin direction control register (P3DIR) to "1" to set P30 to output mode.
(5) Set the SC1MD0 register. Select the start condition. SC1MD0 (x'3F9A') bp3 : SC1STE = 1	(5) Set the SC1STE flag of the SC1MD0 register to "1" to enable start condition.


Setup Procedure	Description
<p>Select the first bit to be transferred. SC1MD0 (x'3F9A') bp4 : SC1DIR = 0</p> <p>(6) Set the SC1MD2 register. Control the output data. SC1MD2 (x'3F9C') bp0 : SC1BRKE = 0</p> <p>Select the added parity bit. SC1MD2 (x'3F9C') bp3 : SC1NPE = 0 bp5-4 : SC1PM1-0 = 00</p> <p>Specify the frame mode. SC1MD2 (x'3F9C') bp7-6 : SC1FM1-0 = 11</p> <p>(7) Set the SC1MD1 register. Select the communication type. SC1MD1 (x'3F9B') bp0 : SC1CMD = 1 bp1 : SC1ICC = 0</p> <p>Select the clock frequency. SC1MD1 (x'3F9B') bp3 : SC1CKM = 1</p> <p>Control the pin function. SC1MD1 (x'3F9B') bp4 : SC1SBOS = 1 bp5 : SC1SBIS = 0 bp7 : SC1IOM = 1</p> <p>(8) Set the interrupt level. SC1ICR (x'03FF7') bp7-6 : SC1LV1-0 = 10</p> <p>(9) Enable the interrupt. SC1ICR (x'03FF7') bp1 : SC1IE = 1</p>	<p>Set the SC1DIR flag of the SC1MD0 register to "0" to select MSB as first transfer bit.</p> <p>(6) Set the SC1BRKE flag of the SC1MD2 register to "0" to select serial data transmission.</p> <p>Set the SC1PM1-0 flag of the SC1MD2 register to "00" to select 0 parity, and set the SC1NPE flag to "0" to add parity bit.</p> <p>Set the SC1FM1-0 flag of the SC1MD2 register to "11" to select 8 bits + 2 stop bits at the frame mode.</p> <p>Set the SC1CMD flag of the SC1MD1 register to "1" to select half-duplex UART.</p> <p>Set the SC1CKM flag of the SC1MD1 register to "1" to select "divided by 8" at source clock.</p> <p>Set the SC1SBOS flag of the SC1MD1 register to "1" to set the TXD1 pin to serial data output. The RXD1 pin can be used as a general port by setting the SC1SBIS flag to "0", the SC1IOM flag to "1".</p> <p>(8) Set the interrupt level by the SC1LV1-0 flag of the serial 1 interrupt control register (SC1ICR).</p> <p>(9) Set the SC1IE flag of the SC1ICR register to "1" to enable the interrupt request. If any interrupt request flag is already set, clear them. [  Chapter 3. 3-1-4 Interrupt Flag Setup ]</p>


Setup Procedure	Description
<p>(10) Set the baud rate timer.</p> <p>(11) Start serial transmission.                      The sending data → TXBUF1                      (x'3F99')</p>	<p>(10) Set the baud rate timer by the TM4MD register, the TM4OC register, and set the TM4EN flag to "1" to start timer 4.                      [  Chapter 6. 6-8 Serial Transfer Clock Output ]</p> <p>(11) Transfer is started by setting the transmission data to the serial transmission data buffer (TXBUF1).                      After transmission has finished, the serial 1 interrupt (SC1IRQ) is generated.</p>

Note : In (5) to (7), each settings can be set at once.

 When the TXD1 / RXD1 pin are connected for communication with 1 channel, the TXD1 pin inputs / outputs serial data. The port direction control register P3DIR switches I/O.

 It is possible to shut down the communication. If the communication should be stopped by force, set SC1SBOS and SC1SBIS of the SC1MD1 register to "0".

 Each flag should be set as its procedure in order. Activation for communication should be operated after all control registers (except Table 12-2-1 : TXBUF1, RXBUF1) are set.

 Only timer 4 can be used as a baud rate timer.  
 For baud rate setup, refer to Chapter 6. 6-8 Serial Transfer Clock Output.

### ■ Reception Setup


Here is the setting example for UART reception with serial interface 1. Table 12-3-24 shows the conditions for reception.

**Table 12-3-24 UART Interface Reception Setup**

Setup item	set to
TXD1/RXD1 pin	Connection (with 1 line)
Frame mode	8bits + 2 stop bit
First transfer bit	MSB
Clock source	Timer 4 output
Type of TXD1 pin	N-ch open-drain
Pull-up resistor of TXD1 pin	added
Parity bit add / check	"0" add / check
Serial interface 1 communication complete interrupt	Enable

An example setup procedure, with a description of each step is shown below.

Setup Procedure	Description
(1) Select prescaler operation. PSCMD (x'3F6F') bp0 : PSCEN = 1	(1) Set the PSCEN flag of the PSCMD register to "1" to select prescaler operation.
(2) Select the clock source. SC1CKS (x'3F9F') bp2-0 : SC1PSC2-0 = 110 bp3 = 1	(2) Set the SC1PSC2-0 flag of the SC1CKS register to "110" to select timer 4 output at clock source. Set bp3 of the SC1CKS register to "1", always.
(3) Control the pin type. SC1ODC (x'3F9E') bp0 : SC1ODC0 = 1 P3PLU (x'3F43') bp0 : P3PLU0 = 1	(3) Set the SC1ODC0 flag of the SC1ODC register to "1" to select N-ch open drain for the TXD1 pin. Set the P3PLU0 flag of the P3PLU register to "1" to add pull-up resistor.
(4) Control the pin direction. P3DIR (x'3F33') bp0 : P3DIR0 = 0	(4) Set the P3DIR flag of the port 3 pin direction control register (P3DIR) to "0" to set P30 (TXD1 pin) to input mode.
(5) Set the SC1MD0 register. Select the start condition. SC1MD0 (x'3F9A') bp3 : SC1STE = 1	(5) Set the SC1STE flag of the SC1MD0 register to "1" to enable start condition.
Select the first bit to be transferred. SC1MD0 (x'3F9A') bp4 : SC1DIR = 0	Set the SC1DIR flag of the SC1MD0 register to "0" to set MSB as the first transfer bit.

Setup Procedure	Description
<p>(6) Set the SC0MD2 register.            Select the added parity bit.            SC1MD2 (x'3F9C')                bp3 : SC1NPE = 0                bp5-4 : SC1PM1-0 = 00</p> <p>Set the frame mode.            SC1MD2 (x'3F9C')                bp7-6 : SC1FM1-0 = 11</p>	<p>(6) Set the SC1PM1-0 flag of the SC1MD2 register to "00" to select 0 parity, and set the SC1NPE flag to "0" to enable the added parity bit.</p> <p>Set the SC1FM1-0 flag of the SC1MD2 register to "11" to select data 8 bits + 2 stop bits.</p>
<p>(7) Set the SC1MD1 register.            Select the communication type.            SC1MD1 (x'3F9B')                bp0 : SC1CMD = 1                bp1 : SC1ICC = 0</p> <p>Select the clock frequency.            SC1MD1 (x'3F9B')                bp3 : SC1CKM = 1</p> <p>Control the pin function.            SC1MD1 (x'3F9B')                bp4 : SC1SBOS = 0                bp5 : SC1SBIS = 1                bp7 : SC1IOM = 1</p>	<p>(7) Set the SC1CMD flag of the SC1MD1 register to "1" and the SC1ICC flag to "0", to select half-duplex UART.</p> <p>Set the SC1CKM flag of the SC1MD1 register to "1" to select "divided by 8" at source clock.</p> <p>Set the SC1SBOS flag of the SC1MD1 register to "0" to set TXD1 pin to port output. Set the SC1SBIS flag to "1" to select serial data input. The RXD1 pin can be used as a general port by setting the SC1IOM flag to "1".</p>
<p>(8) Set the interrupt level.            SC1ICR (x'03FF7')                bp7-6 : SC1LV1-0 = 10</p>	<p>(8) The SC1LV1-0 flag of the serial 1 interrupt control register (SC1ICR) sets interrupt level.</p>
<p>(9) Enable the interrupt.            SC1ICR (x'03FF7')                bp1 : SC1IE = 1</p>	<p>(9) Set the SC1IE flag of the SC1ICR register to "1" to enable interrupt request. If interrupt request flag has already been set, clear them.            [  Chapter 3. 3-1-4 Interrupt Flag Setup ]</p>
<p>(10) Set the baud rate timer.</p>	<p>(10) The TM4MD register, TM4OC register set the baud rate. And the TM4EN flag is set to "1" to start timer 4.            (Refer to Chapter 6. 6-8 Serial Transfer Clock Output.)</p>



Setup Procedure	Description
(11) Start serial reception. The received data → input to TXD1	(11) After TXD1 pin inputs serial data to recognize start condition, the received data is stored to the received data buffer RXBUF1. When reception has finished, the serial 1 interrupt SC1IRQ is generated.

Note : In (5) to (7), each settings can be set at once.



When the TXD1 / RXD1 pin are connected for communication with 1 channel, the TXD1 pin inputs / outputs serial data. The port direction control register P3DIR switches I/O. At reception, set SC1SBIS of the SC1MD1 register to "1" to select serial data input. The RXD1 pin can be used as a general port.



It is possible to shut down the communication. If the communication should be stopped by force, set SC1SBOS and SC1SBIS of the SC1MD1 register to "0".



Each flag should be set as its procedure in order. Activation for communication should be operated after all control registers (except Table 12-2-1 : TXBUF1, RXBUF1) are set.



Only timer 4 can be used as a baud rate timer.  
 For baud rate setup, refer to Chapter 6. 6-8 Serial Transfer Clock Output.

### 12-3-5 IC Card I/F

This serial interface 1 can be used for IC card communication with UART function. For more detail about protocol of IC card communication, refer to ISO / IEC 7816 series, 10373.

■Condition for Standard Use of IC Card Communication

Table 12-3-25 shows the general condition for IC card communication. Each value and format are recommended at ISO.

**Table 12-3-25 Condition for Standard IC Card Communication**

Communication protocol / data format	as IC card operated : ATR at normal communication : T=0, 1
Clock frequency	fosc = 1 to 5 MHz
Recommended transfer rate	9600 bps (at fosc = 3.5712 MHz)
Frame	8 data bits + parity bit
Communication error report signal	1 to 2 bits data length

■Functions

IC card communication on this serial interface is available by limiting the condition at half-duplex UART. Table 12-3-26 shows the IC card communication functions.

**Table 12-3-26 IC Card Communication Functions**

ATR communication	Data transmission and reception	– (only transfer is available)
	Available communication error report signal	1 to 2 bits data length
T=0 data communication		√ (transmission, reception)
T=1 data communication		√ (transmission, reception)
Maximum clock frequency		fosc=20 MHz
Disparity in transfer rate (recommended rate : 9600 bps)		Transfer rate in real : 9704 bps <sup>(*)</sup> disparity : 1.1 %
Maximum transfer rate		300 kbps
*1 : Setup of baud rate by timer 4. condition : fosc=3.5712 MHz Timer 4 clock source : fosc Timer 4 compare register setup value : x'16'		

■ATR Data Format

ATR data is transferred from IC card to the reader/writer in protocol ATR, at activation of IC card. The character waiting time of ATR data generally consists of 8-bit character data, parity bit and guardtime, up to 2-bit data length.

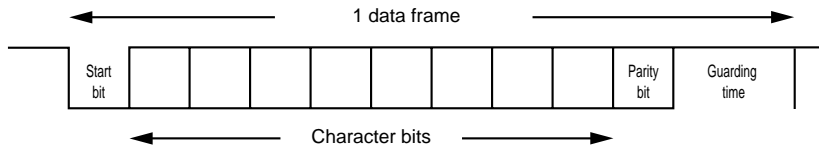


Figure 12-3-19 ATR Communication Data Format

■Error Report at ATR Data Communication

At ATR data communication, if the reader/writer cannot receive data, IC card receive an error report. Communication error is determined by parity bit in the character waiting time. If the communication error is generated, the reader/writer outputs "L" data with 1 bit or 2 bit data length, during guardtime. At normal communication, guardtime in the character waiting time is always "H". This serial interface can determine and receive the communication error by hard disk, but cannot report the reception error. Table 12-3-20 shows the reception timing of communication error report.

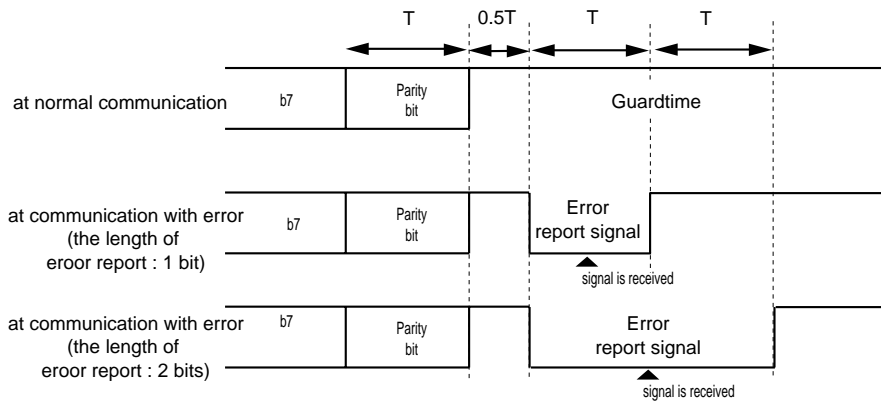


Figure 12-3-20 Report Timing of Communication Error Signal

■Transmission / Reception of T=0, T=1 Data using with Protocol T=0, T=1

The character waiting time of T = 0, 1 data has the same constitution to ATR data. But, the receiver does not report a communication error. At communication of T = 0, 1 data, set the same setup to ATR data for mode register.

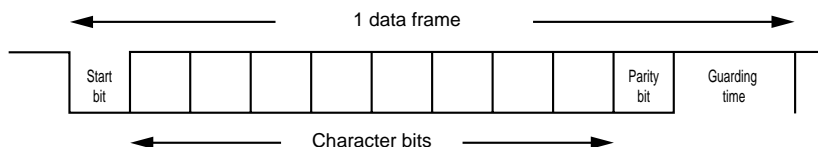


Figure 12-3-21 Communication Data Format (T=0, 1)

■Control of Error Report Signal Reception and the Timing at ATR Data Communication

This serial interface can receive an error report signal with 1 bit or 2 bits data length. The reception use the error flag (the SC1FEF flag of the SC1STR register) at UART communication. When an error report is received, the SC1FEF flag is set to "1" by generation of the communication complete interrupt SC1IRQ. The SC1FEF flag should be determined before the next communication is finished, because the SC1FEF flag is renewed at generation of SC1IRQ.

The reception timing of an error report signal should be switched depending on the length of the reception error report signal. The SC1CE1-0 flag of the SC1MD0 register can set that reception timing. For more detail of the SC1CE1-0 flag setup, refer to "XII-14 Setup for input edge / output edge".

Table 12-3-27 Control of Error Report Signal Reception Timing

the length of error report signal	Setup of the SC1CE1-0 flag
1 bit	SC1CE1-0 = "01"
2 bits	SC1CE1-0 = "00"

■Signal Pin Setup

At IC card communication, connect the TXD1 / RXD1 pin (1 channel) for data I/O from TXD1 pin. For connection of TXD1 / RXD1, set the SC1IOM flag of the SC1MD1 register. Also, at ATR data transmission, set the SC1SBIS flag of the SC1MD1 register to "serial input" to receive the communication error report. Select Nch-open drain type for TXD1.

### ■Mode Register Setup

Select IC card mode or half-duplex UART at communication mode. The SC1CMD flag and SC1ICC flag of the SC1MD1 register can set the mode selection. Table 12-3-28 shows the setup for mode register at IC card communication, and at UART communication. Other control registers and flags should be set as same at UART communication.

**Table 12-3-28 Control at UART Communication, and at IC Card Communication**

Register	Flag	Setup	
		UART communication (half-duplex)	IC card communication
SC1MD0	SC1CE1-0	"0, 0" (transmission : at falling edge, reception : at rising edge)	< at ATR transmission > Error report signal length = 1 bit : "0, 1" (transmission: at falling, reception : at falling)
			< at ATR transmission, at transmission and reception as T=0,1 > Error report signal length = 2 bit : "0, 0" (transmission : at falling, reception : at rising)
SC1MD1	SC1CMD	"1"(half-duplex UART)	"1"(half-duplex UART)
	SC1ICC	"1"(half-duplex UART)	"1"(IC card mode)
	SC1SBIS	selectable	"1"(serial input)
	SC1IOM	selectable	"1"(serial input from TXD1)
SC1MD2	SC1NPE	selectable	"0"(with parity)
	SC1FM1-0	selectable	"1, 1" (data 8 bits + stop 2 bits)
SC1ODC / P3PLU	SC1ODC0 / P3PLU0	selectable	"1"(Nch-open-drain) / "1"(added pull-up resistor)
Other registers and flags should be set the same as UART communication.			

The following items are the same to half-duplex UART communication.  
Reference as follows ;

■First Transfer Bit Setup

Refer to : XII-12

■Transmission Data Buffer

Refer to : XII-12

■Transfer Bit Count and First Transfer Bit

Refer to : XII-13

■Received Data Buffer

Refer to : XII-13

■Receive Bit Count and First Transfer Bit

Refer to : XII-13

■Sequence Communication

Refer to : XII-33

■Received Buffer Empty Flag

Refer to : XII-16

■Transmission Buffer Empty Flag

Refer to : XII-16

■BUSY Flag

Refer to : XII-16

■Emergency Reset

Refer to : XII-16

■Activation Factor

Refer to : XII-30

■Transmission

Refer to : XII-30

■Reception

Refer to : XII-30

■Reception Error

Refer to : XII-32

■Transfer Rate Setup

Refer to : XII-36

■Transmission Timing (ATR Data Communication, T=0, 1 Data Communication)

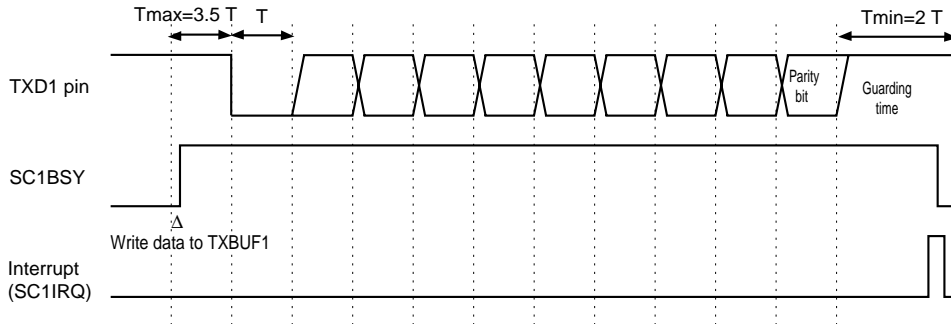


Figure 12-3-22 Transmission Timing (ATR Data, T=0, 1 Data Communication)

■Reception Timing (T=0, 1 Data Communication)

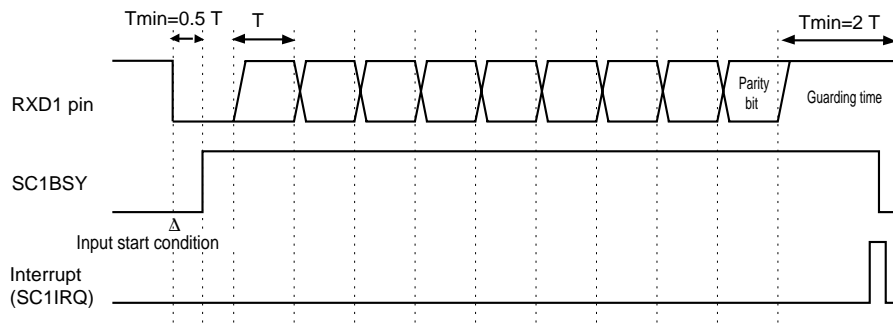


Figure 12-3-23 Reception Timing (T=0, 1 Data Communication)

■Pin Setup (setup of TXD1 / RXD1 pin connection for transmission)

Table 12-3-29 shows the pins setup at IC card communication by connection of the TXD1 pin and the RXD1 pin. The RXD1 pin can be used as a general port.

**Table 12-3-29 Pin Setup at IC Card Communication (at transmission)**

Setup item	Data output pin	Data input pin
	TXD1 pin	RXD1 pin
Pin	P30	P31
TXD1/RXD1 pin	Connection of TXD1/RXD1 pin	
	SC1MD1(SC1IOM)	
Function	Serial data output	at ATR communication : serial data input at T=0,1 : "1" input
	SC1MD1(SC1SBOS)	SC1MD1(SC1SBIS)
Style	Nch-open-drain	-
	SC1ODC(SC1ODC0)	
I/O	Output mode	-
	P3DIR(P3DIR0)	
Pull-up	Added	-
	P3PLU(P3PLU0)	

■Pin Setup (setup of TXD1 / RXD1 pin connection for reception)

Table 12-3-30 shows the pins setup at IC card communication by connection of the TXD1 pin and the RXD1 pin. The RXD1 pin can be used as a general port.

**Table 12-3-30 Pin Setup at IC Card Communication (at reception)**

Setup item	Data output pin	Data input pin
	TXD1 pin	RXD1 pin
Pin	P30	P31
TXD1/RXD1 pin	Connection of TXD1/RXD1 pin	
	SC1MD1(SC1IOM)	
Function	port	serial data input
	SC1MD1(SC1SBOS)	SC1MD1(SC1SBIS)
Style	Nch-open-drain	-
	SC1ODC(SC1ODC0)	
I/O	Input mode	-
	P3DIR(P3DIR0)	-
Pull-up	Added	-
	P3PLU(P3PLU0)	



## 12-3-6 Setup Example

### ■Transmission Setup Example

Here is the setting example for ATR data and T = 0, 1 data transmission at IC card communication with serial 1. Table 12-3-31 shows the conditions for transmission .



**Table 12-3-31 Transmission Setup**

Setup item	selected to
TXD1/RXD1 pin	Connection (with 1 Channel)
Frame mode	8 bits + 2 stop bits
First transfer bit	LSB
Clock source	Timer 4 output
Pin type of TXD1	N-ch open-drain
Pull-up resistor of TXD1 pin	Added
Parity bit add / check	"0" add / check
Communication error report signal (at ATR transmission)	2 bits data length
Serial interface 1 communication complete interrupt	Enable

An example setup procedure, with a description of each step is shown below.

Setup Procedure	Description
(1) Select prescaler operation. PSCMD (x'3F6F') bp0 : PSCEN = 1	(1) Set the PSCEN flag of the PSCMD register to "1" to select prescaler operation.
(2) Select the clock source. SC1CKS (x'3F9F') bp2-0 : SC1PSC2-0 = 110 bp3 = 1	(2) Set the SC1PSC2-0 flag of the SC1CKS register to "110" to select timer 4 output at clock source. Set bp3 of the SC1CKS register to "1", always.
(3) Control the pin type. SC1ODC (x'3F9E') bp0 : SC1ODC0 = 1 P3PLU (x'3F43') bp0 : P3PLU0 = 1	(3) Set the SC1ODC0 flag of the SC1ODC register to "1" to select N-ch open drain for TXD1 pin type. Set the P3PLU0 flag of the P3PLU register to "1" to add pull-up resistor.
(4) Control the pin direction. P3DIR (x'3F33') bp0 : P3DIR0 = 1	(4) Set the P3DIR0 flag of the port 3 pin direction control register (P3DIR) to "1" to set P30 to output mode.
(5) Set the SC1MD0 register. Select the start condition. SC1MD0 (x'3F9A') bp3 : SC1STE = 1	(5) Set the SC1STE flag of the SC1MD0 register to "1" to enable start condition.

Setup Procedure	Description
<p>Select the first bit to be transferred. SC1MD0 (x'3F9A') bp4 : SC1DIR = 1</p> <p>Select the transfer edge. SC1MD0 (x'3F9A') bp7-6 : SC1CE1-0 = 00</p>	<p>Set the SC1DIR flag of the SC1MD0 register to "1" to set LSB as a first transfer bit.</p> <p>Set the SC1CE1-0 flag of the SC1MD0 register to "00" to set the transmission data output edge to "falling", and the received data input edge "rising". At ATR data transfer, the communication error report signal with 2 bits data length can be received. At T=0, 1 data communication, set the SC1CE1-0 flag to "00", always.</p>
<p>(6) Set the SC0MD2 register. Control the output data. SC1MD2 (x'3F9C') bp0 : SC1BRKE = 0</p> <p>Select the added parity bit. SC1MD2 (x'3F9C') bp3 : SC1NPE = 0 bp5-4 : SC1PM1-0 = 00</p> <p>Specify the frame mode. SC1MD2 (x'3F9C') bp7-6 : SC1FM1-0 = 11</p>	<p>(6) Set the SC1BRKE flag of the SC1MD2 register to "0" to select serial data transfer.</p> <p>Set the SC1PM1-0 flag of the SC1MD2 register to "00" to select 0 parity, and set the SC1NPE flag to "00" to enable the added parity bit.</p> <p>Set the SC1FM1-0 flag of the SC1MD2 register to "11" to set the frame mode to 8 bits + 2 stop bits.</p>
<p>(7) Set the SC1MD1 register. Select the communication style. SC1MD1 (x'3F9B') bp0 : SC1CMD = 1 bp1 : SC1ICC = 1</p> <p>Select the clock frequency. SC1MD1 (x'3F9B') bp3 : SC1CKM = 1</p> <p>Control the pin function. SC1MD1 (x'3F9B') bp4 : SC1SBOS = 1 bp5 : SC1SBIS = 1 bp7 : SC1IOM = 1</p>	<p>(7) Set the SC1CMD flag of the SC1MD1 register to "1", and the SC1ICC flag to "1" to select IC card mode of half-duplex UART.</p> <p>Set the SC1CKM flag of the SC1MD1 register to "1" to select source clock divided by 8.</p> <p>Set the SC1SBOS flag of the SC1MD1 register to "1" to set TXD1 pin "serial data output". Set the SC1SBIS flag to "1" to select "serial data input". The RXD1 pin can be used as a general port by setting the SC1IOM flag to "1".</p>

Setup Procedure	Description
(8) Set the interrupt level. SC1ICR (x'03FF7') bp7-6 : SC1LV1-0 = 10	(8) Set the interrupt level by the SC1LV1-0 flag of the serial 1 interrupt control register (SC1ICR).
(9) Enable the interrupt. SC1ICR (x'3FF7') bp1 : SC1IE = 1	(9) Set the SC1IE flag of the SC1ICR register to "1" to enable the interrupt request. If interrupt request flag has already been set, clear them. [  Chapter 3 3-1-4. Interrupt Flag Setup ]
(10) Set the baud rate timer.	(10) Set the baud rate timer by the TM4MD register, TM4OC register to set the TM4EN flag to "1" to start timer 4. [  Chapter 6 6-8. Serial Interface Transfer Clock Output ]
(11) Start serial interface transfer. The transmission data →TXBUF1 (x'3F99')	(11) The transfer is started by setting the transmission data to the serial transmit data buffer (TXBUF1). The serial 1 interrupt (SC1IRQ) is generated after the transfer has finished. At ATR data transfer, if the SC1FEF flag of the SC1STR register is "0", that means the communication has finished without error, and if the SC1FEF flag is "1", that means a communication error is generated, and the transfer should be operated again.

Note : In (5) to (7), each settings can be set at once.



At IC card communication, the TXD1 pin set to TXD1/RXD1 pins inputs/outputs serial data. The RXD1 pin can be used as a general port.



It is possible to shut down the communication. If the communication should be stopped by force, set SC1SBOS and SC1SBIS of the SC1MD1 register to "0".



Each flag should be set as its procedure in order. Activation for communication should be operated after all control registers (except Table 12-2-1 : TXBUF1, RXBUF1) are set.



Only timer 4 can be used as a baud rate timer.  
For the baud rate setup, refer to Chapter 6. 6-8 Serial Transfer Clock Output.

■ Setup Example for T=0, 1 Data Reception

Setup example for T-0,1 data transfer of IC card communication with serial 1 is shown below.

Table 12-3-32 shows the conditions at reception.



**Table 12-3-32 Reception Setup**

Setup item	selected to
TXD1/RXD1 pin	Connection (with 1 Channel)
Frame mode	8 bits + 2 stop bits
First transfer bit	LSB
Clock source	Timer 4 output
Pin type of TXD1	N-ch open-drain
Pull-up resistor of TXD1 pin	Added
Parity bit add / check	"0" add / check
Serial interface 1 communication complete interrupt	Enable


An example setup procedure, with a description of each step is shown below.


Setup Procedure	Description
(1) Select prescaler operation. PSCMD (x'3F6F') bp0 : PSCEN = 1	(1) Set the PSCEN flag of the PSCMD register to "1" to select prescaler operation.
(2) Select the clock source. SC1CKS (x'3F9F') bp2-0 : SC1PSC2-0 = 110 bp3 = 1	(2) Set the SC1PSC2-0 flag of the SC1CKS register to select timer 4 for clock source. Set bp3 of the SC1CKS register to "1", always.
(3) Control the pin type. SC1ODC (x'3F9E') bp0 : SC1ODC0 = 1 P3PLU (x'3F43') bp0 : P3PLU0 = 1	(3) Set the SC1ODC0 flag of the SC1ODC register to "1" to select N-ch open drain for the TXD pin. Set the P3PLU0 flag of the P3PLU register to "1" to add pull-up resistor.
(4) Control the pin direction. P3DIR (x'3F33') bp0 : P3DIR0 = 0	(4) Set the P3DIR0 flag of the port 3 pin direction control register (P3DIR) to "0" to set P30 to input mode.
(5) Set the SC1MD0 register. Select the start condition. SC1MD0 (x'3F9A') bp3 : SC1STE = 1	(5) Set the SC1STE flag of the SC1MD0 register to "1" to enable start condition.


Setup Procedure	Description
<p>Select the first bit to be transferred. SC1MD0 (x'3F9A') bp4 : SC1DIR = 1</p>	<p>Set the SC1DIR flag of the SC1MD0 register to "1" to set LSB as the first transfer bit.</p>
<p>Select the transfer edge. SC1MD0 (x'3F9A') bp7-6 : SC1CE1-0 = 00</p>	<p>Set the SC1CE1-0 flag of the SC1MD0 register to "00" to set the transmission data output edge to "falling", the received data input edge to "rising".</p>
<p>(6) Set the SC1MD2 register. Control the output data. SC1MD2 (x'3F9C') bp0 : SC1BRKE = 0</p>	<p>(6) Set the SC1BRKE flag of the SC1MD2 register to "0" to select serial data transfer.</p>
<p>Select the added parity bit. SC1MD2 (x'3F9C') bp3 : SC1NPE = 0 bp5-4 : SC1PM1-0 = 00</p>	<p>Set the SC1PM1-0 flag of the SC1MD2 register to "00" to select 0 parity, and set the SC1NPE flag to "0" to enable the added parity bit.</p>
<p>Specify the frame mode. SC1MD2 (x'3F9C') bp7-6 : SC1FM1-0 = 11</p>	<p>Set the SC1FM1-0 flag of the SC1MD2 register to "11" to select 8 bits + 2 stop bits for frame mode.</p>
<p>(7) Set the SC1MD1 register. Select the communication style. SC1MD1 (x'3F9B') bp0 : SC1CMD = 1 bp1 : SC1ICC = 1</p>	<p>(7) Set the SC1CMD flag of the SC1MD1 register to "1", the SC1ICC flag to "1" to select IC card mode of half-duplex UART.</p>
<p>Select the clock frequency. SC1MD1 (x'3F9B') bp3 : SC1CKM = 1</p>	<p>Set the SC1CKM flag of the SC1MD1 register to select source clock divided by 8.</p>
<p>Control the pin function. SC1MD1 (x'3F9B') bp4 : SC1SBOS = 0 bp5 : SC1SBIS = 1 bp7 : SC1IOM = 1</p>	<p>Set the SC1SBOS flag of the SC1MD1 register to "0" to set the TXD1 pin to "port". Set the SC1SBIS flag to "1" to select "serial data input". Set the SC1IOM flag to "1" to select "data input from the TXD1 pin". Then, the RXD1 pin can be used as a general port.</p>


Setup Procedure	Description
(8) Set the interrupt level. SC1ICR (x'03FF7') bp7-6 : SC1LV1-0 = 10	(8) Set the interrupt level by the SC1LV1-0 flag of the serial 1 interrupt control register (SC1ICR).
(9) Enable the interrupt. SC1ICR (x'3FF7') bp1 : SC1IE = 1	(9) Set the SC1IE flag of the SC1ICR register to "1" to enable the interrupt request. If interrupt request flag is already set, clear them.  [  Chapter 3 3-1-4. Interrupt Flag Setup ]
(10) Set the baud rate timer.	(10) Set the baud rate timer by the TM4MD register, TM4OC register to set the TM4EN flag to "1" to start timer 4.  [  Chapter 6 6-8. Serial Transfer Clock Output ]
(11) Start serial reception. The reception data → RXBUF1 (x'3F98')	(11) After TXD1 pin inputs serial data to recognize start condition, the received data is stored to the received data buffer RXBUF1.  When reception finishes, the serial 1 interrupt (SC1IRQ) is generated.

Note : In (5) to (7), each settings can be set at once.

 At IC card communication, the TXD1 pin connected with TXD1/RXD1 pins inputs/outputs serial data. The RXD1 pin can be used as a general port.

 It is possible to shut down the communication. If the communication should be stopped by force, set SC1SBOS and SC1SBIS of the SC1MD1 register to "0".

 Each flag should be set as its procedure in order. Activation for communication should be operated after all control registers (except Table 12-2-1 : TXBUF1, RXBUF1) are set.

 Only timer 4 can be used as a baud rate timer.  
 For the baud rate setup, refer to Chapter 6. 6-8 Serial Transfer Clock Output.




## 13-1 Overview

This LSI contains a serial interface 2 can be used for clock synchronous serial communication.

### 13-1-1 Functions

Table 13-1-1 shows the serial interface 2 functions.

**Table 13-1-1 Serial Interface 2 Functions**

Communication style	Clock synchronous
Interrupt	SC2IRQ
Used pins	SBO2,SB12,SBT2
3 channels type	√
2 channels type	√(SBO2,SBT2)
Start condition	√
Transfer bit count	1 to 8 bit
First transfer bit	√
Input edge / Output edge	√
Continuous operation (with ATC1)	√
Clock source	fosc/2 fosc/4 fosc/16 fosc/32 fs/2 fs/4 timer 3 output external clock
Maximum transfer rate	2.5 MHz
fosc : machine clock (for high speed oscillation) fs : system clock [  Chapter 2 2-5. Clock Switching ]	



### 13-1-2 Block Diagram

■ Serial Interface 2 Block Diagram

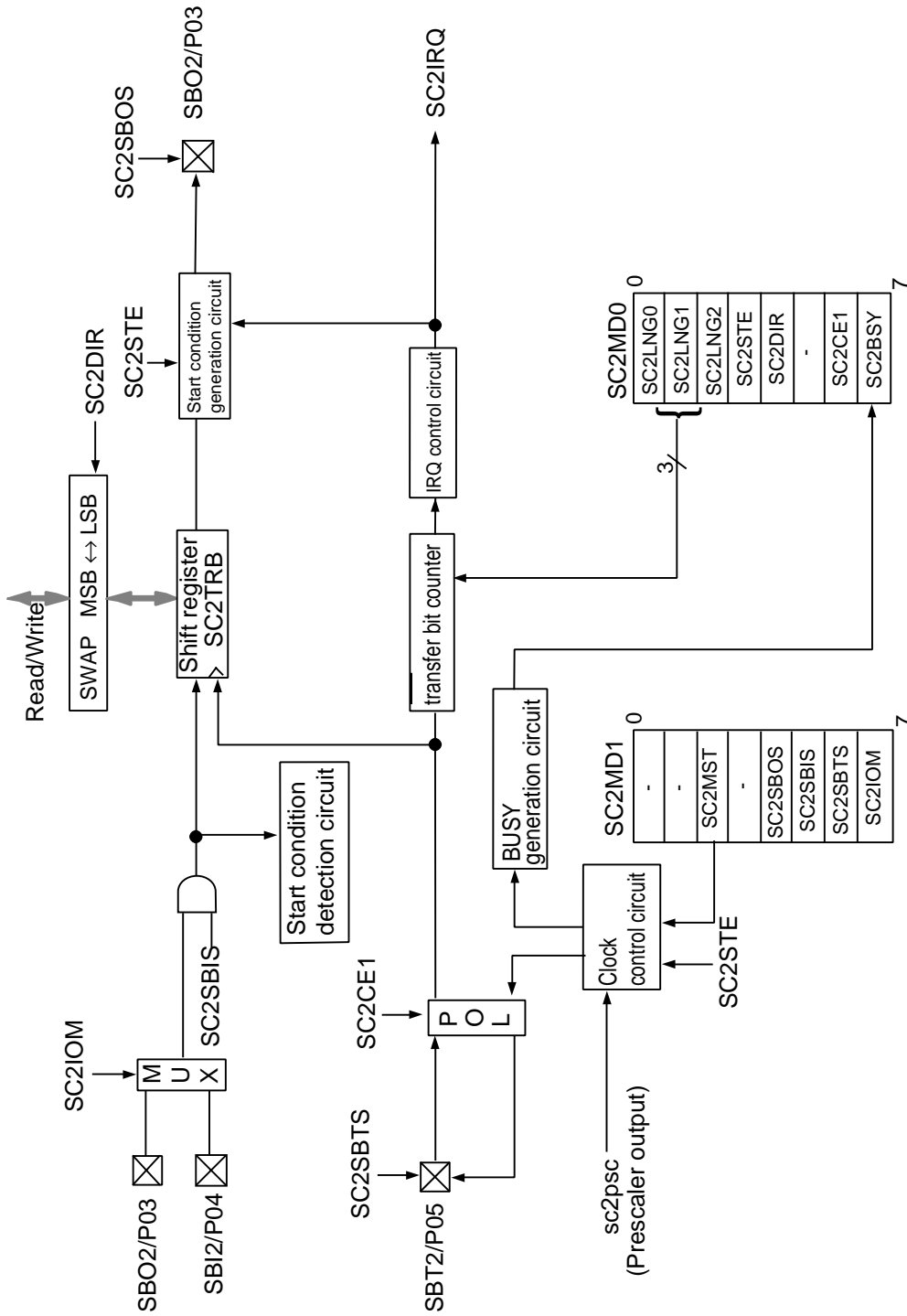


Figure 13-1-1 Serial Interface 2 Block Diagram

## 13-2 Control Registers

### 13-2-1 Registers List

Table 13-2-1 shows the registers to control serial interface 2.

**Table 13-2-1 Serial Interface 2 Control Registers List**

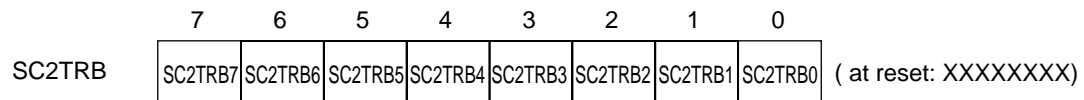
	Register	Address	R/W	Function	Page
Serial interface 2	SC2MD0	x'03FA0'	R/W	Serial interface 2 mode register 0	XIII - 6
	SC2MD1	x'03FA1'	R/W	Serial interface 2 mode register 1	XIII - 7
	SC2TRB	x'03FA2'	R/W	Serial interface 2 transmit/receive shift register	XIII - 5
	SC2ODC	x'03FA6'	R/W	Serial interface 2 port control register	XIII - 8
	SC2CKS	x'03FA7'	R/W	Serial interface 2 transfer clock selection register	XIII - 8
	PSCMD	x'03F6F'	R/W	Prescaler control register	V - 6
	P0DIR	x'03F30'	R/W	Port 0 direction control register	IV - 8
	P0PLU	x'03F40'	R/W	Port 0 pull-up control register	IV - 8
	SC2ICR	x'03FF8'	R/W	Serial interface 2 interrupt control register	III - 36

R /W : Readable / Writable

## 13-2-2 Data Register

Serial interface 2 has a 8-bit serial data register.

### ■ Serial Interface 2 Transmission / Reception Shift Register (SC2TRB)



**Figure 13-2-1 Serial Interface 2 Transmission / Reception Shift Register  
(SC2TRB : x'03FA2', R/W)**

### 13-2-3 Mode Registers

■Serial Interface 2 Mode Register 0 (SC2MD0)

SC2BSY flag is only for reading

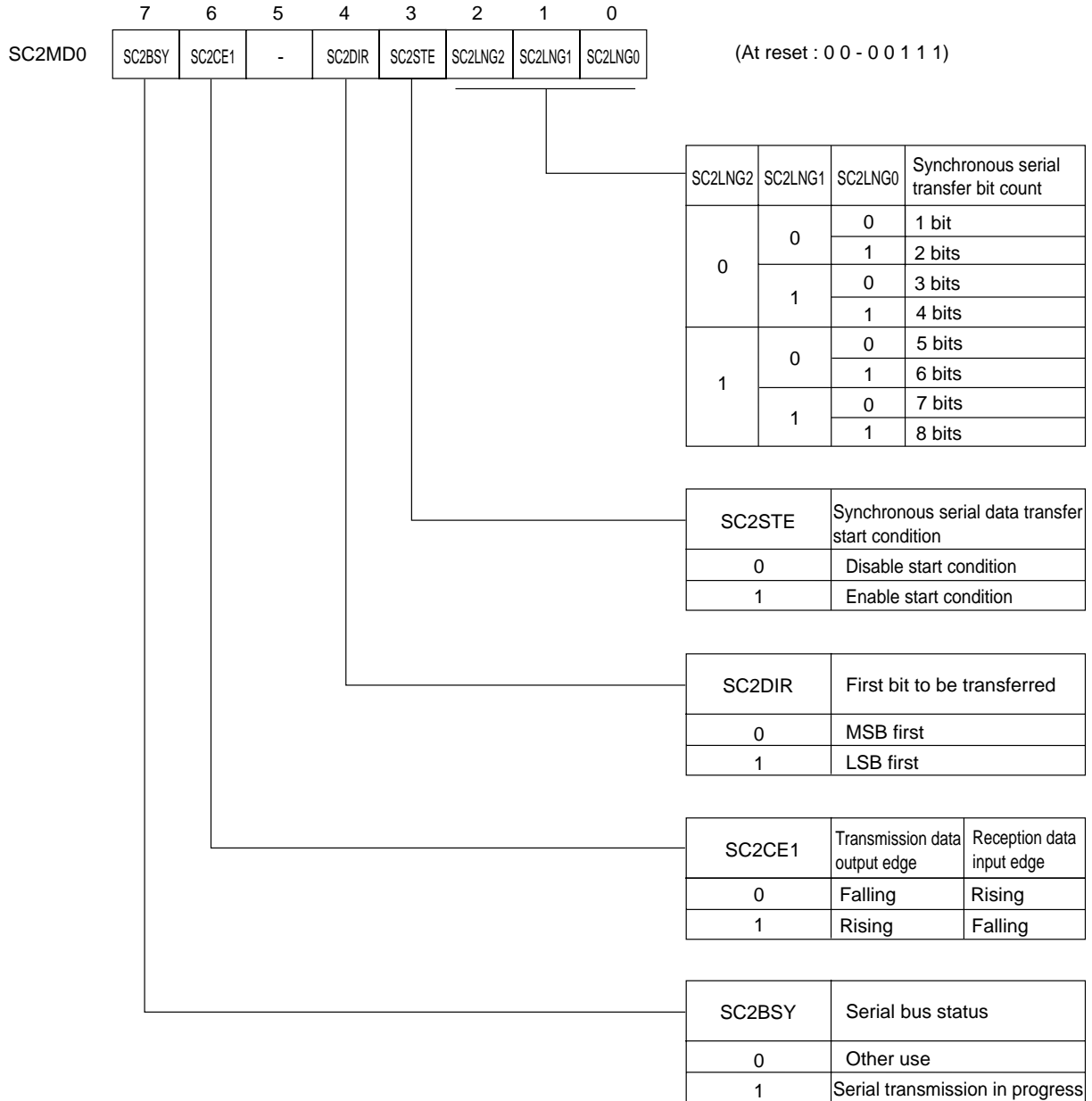
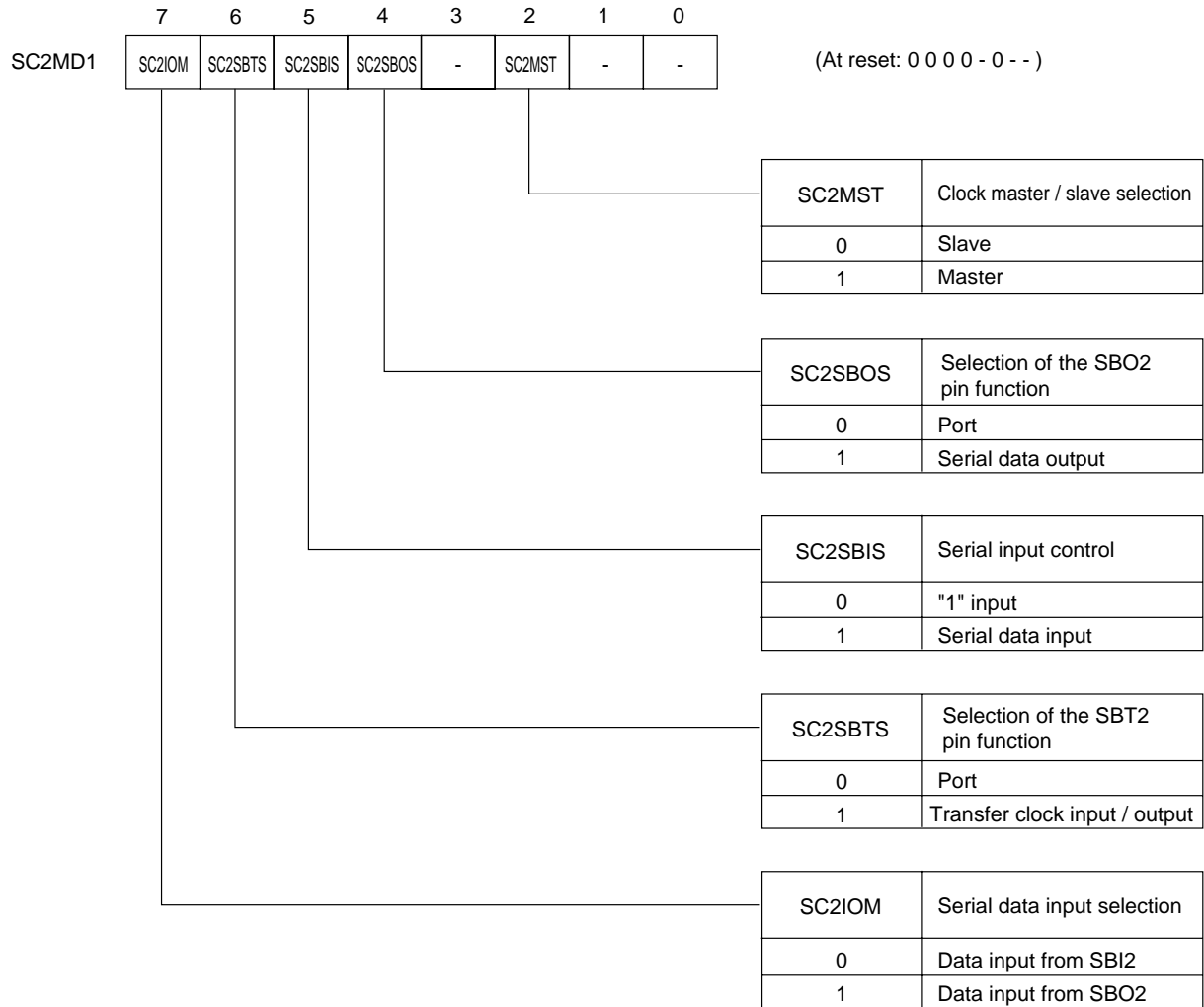


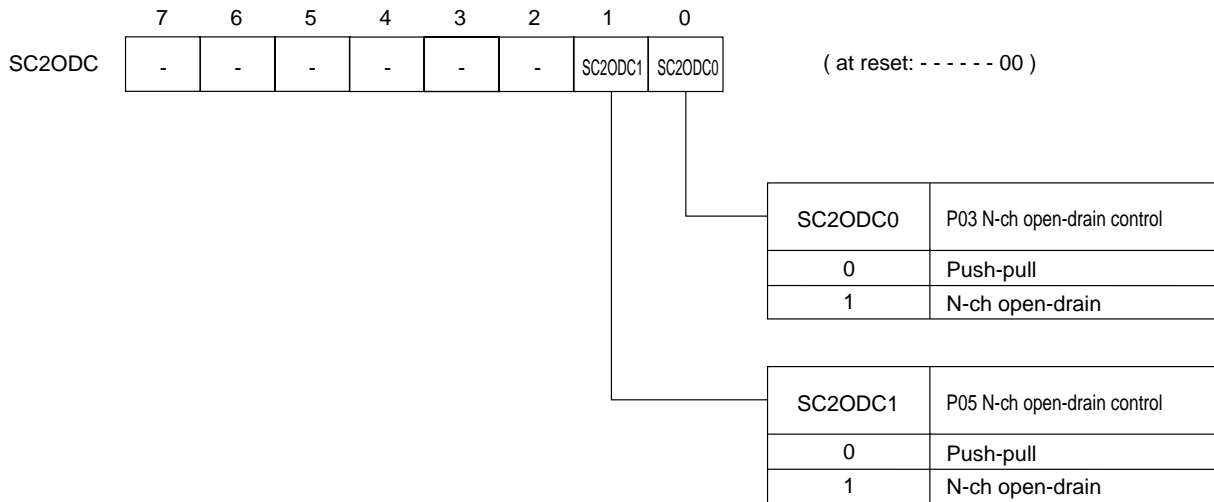
Figure 13-2-2 Serial Interface 2 Mode Register 0 (SC2MD0 : x'03FA0', R/W)

■Serial Interface 2 Mode Register 1 (SC2MD1)



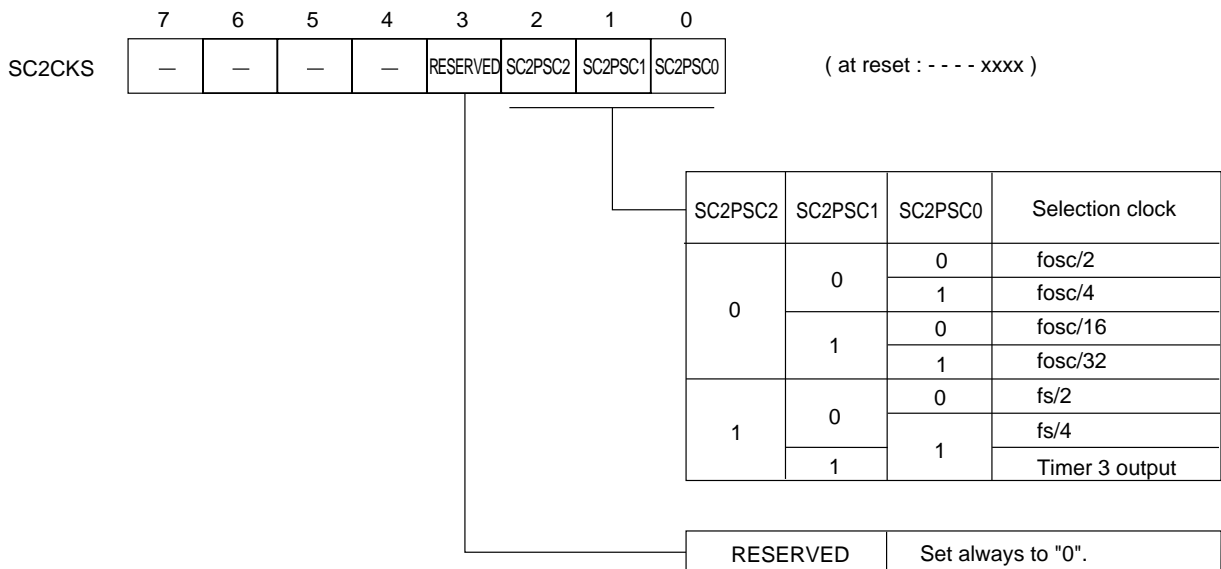
**Figure 13-2-3 Serial Interface 2 Mode Register 1 (SC2MD1 : x'03FA1', R/W)**

■Serial Interface 2 Port Control Register (SC2ODC)




**Figure 13-2-4 Serial Interface 2 Port Control Register (SC2ODC : x'03FA6', R/W)**

■Serial Interface 2 Transfer Clock Selection Register (SC2CKS)



**Figure 13-2-5 Serial Interface 2 Transfer Clock Selection Register (SC2CKS : x'03FA7', R/W)**

 When timer output is selected as serial interface transfer clock, select fosc as a clock source of the timer. If other clock is selected, normal transfer of serial interface data is not guaranteed.

## 13-3 Operation

Serial interface 2 is clock synchronous serial interface.

### 13-3-1 Clock Synchronous Serial Interface

#### ■Activation Factor for Communication

Table 13-3-1 shows the activation source for communication. At master, a transfer clock is generated by setting data to the transmit / receive shift register SC2TRB, or by start condition. Signals input from SBT2 pin inside of serial interface are masked to prevent errors by noise, except during communication. This mask is automatically released by setting data to SC2TRB (writing to the SC2TRB register), or inputting start condition to the data input pin. Therefore, at slave communication, input external clock after setting data to SC2TRB, or inputting start condition.

**Table 13-3-1 Synchronous Serial Interface Activation Factor**

	Activation factor	
	Transmission	Reception
Master communication	Set the transmission data	Set dummy data
		Input start condition
Slave communication	Input clock after the transmission data is set	Input clock after dummy data is set
		Input clock after start condition is input

#### ■Transfer Bit Count Setup

The transfer bit count can be selected from 1 bit to 8 bits. Set the SC2LNG 2 to 0 flag of the SC2MD0 register (at reset : 111). The SC2LNG 2 to 0 flag holds the former value, until it is set again.



The SBT2 pin is masked inside of serial interface, to prevent errors by noise, except during communication. At slave, input clock to the SBT2 pin after setting data to SC2TRB or inputting start condition.

■Start Condition Setup

Start condition can be selected, enable or disable. Set the SC2STE flag of the SC2MD0 register. When the start condition is enabled, the bit counter is cleared as start condition is input during communication, then, the communication is automatically restarted. When the data line (SBI2 pin (with 3 channels) or SBO2 pin (with 2 channels)) changes from "H" to "L" as clock line(SBT2 pin) is "H", start condition is enabled.

■First Transfer Bit Setup

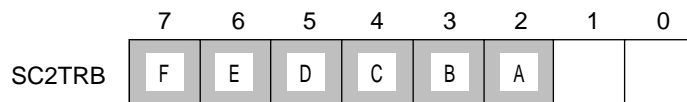
The SC2DIR flag of the SC2MD0 register can set the first bit to be transferred. LSB or MSB can be selected.

■Transmit, Receive Data Buffer

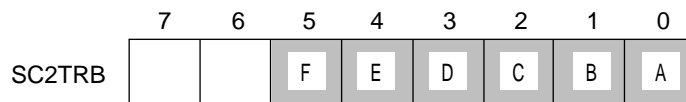
The common data register, the transmit /receive shift register SC2TRB is used at reception and transmission. The transmission data should be set to SC2TRB. Data by 1 bit is transferred in shifts by transfer clock. And the received data by 1 bit is stored to SC2TRB in shifts.

■Transfer Bit Count and First Transfer Bit

When the transfer bit count is 1 to 7 bits, data storage way to the transmit/receive shift register SC2TRB depends on the first transfer bit. When MSB is the first bit to be transferred, use the upper bits of SC2TRB for storage. In figure 13-3-1-1, if data "A" to "F" are stored to bp2 to bp7 of SC2TRB as the transfer bit count is 6 bits, data is transferred from "F" to "A". When LSB is the first bit to be transferred, use the lower bits of SC2TRB for storage. In figure 13-3-1-2, if data "A" to "F" are stored to bp0 to bp5 of SC2TRB, as the transfer bit count is 6 bits, data is transferred from "A" to "F".



**Figure 13-3-1-1 Transfer Bit Count and First Transfer Bit (MSB First)**

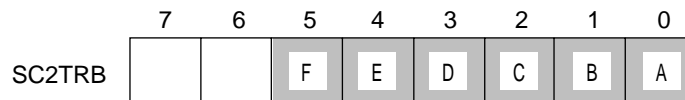


**Figure 13-3-1-2 Transfer Bit Count and First Transfer Bit (LSB First)**

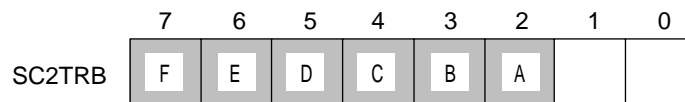


#### ■Receive Bit Count and First Transfer Bit

When the transfer bit count is 1 to 7 bits, data storage way to the transmit/receive shift register SC2TRB depends on the first transfer bit. When MSB is the first bit to be transferred, the lower bits of SC2TRB are used for storage. In figure 13-3-1-3, as the transfer bit count is 6 bits, data "A" to "F" are stored to bp0 to bp5 of SC2TRB, and they are transferred from "F" to "A". When LSB is the first bit to be transferred, use the upper bits of SC2TRB for storage. In figure 13-3-1-4, data "A" to "F" are stored to bp2 to bp7 of SC2TRB, as the transfer bit count is 6 bits, and they are transferred from "A" to "F".



**Figure 13-3-1-3 Receive Bit Count and First Transfer Bit (MSB First)**



**Figure 13-3-1-4 Receive Bit Count and First Transfer Bit (LSB First)**

#### ■Continuous Communication

Serial interface 2 can be started by automatic data transfer function ATC1, built-in this LSI. If ATC1 is used for activation, data can be continuously transferred up to 255 byte. The communication blank, from the generation of the communication complete interrupt SC2IRQ to the generation of the next transfer clock, is up to 18 machine cycles + 2 transfer clocks. For activation by ATC1, refer to chapter 15 Automatic Transfer Controller, Transfer mode 6 to 7.




If start condition is input for activation again, during communication, the transmission data becomes invalid. If the transmission should be operated again, set the transmission data to SC2TRB, again.

■Clock Setup

Clock source is selected from the dedicated prescaler by the SC2CKS register and timer 3 output. The dedicated prescaler is started by selecting "prescaler operation" by the PSCMD (x'03F6F) register. The SC2MST flag of the SC2MD1 register can select the internal clock (clock master), or the external clock (clock slave). Even if the external clock is selected, the internal clock with same frequency to the external clock, should be set by the SC2CKS register, because the internal clock generates the interrupt flag SC2IRQ. Table 13-3-2 shows the internal clock source which can be set by the SC2CKS register.

**Table 13-3-2 Synchronous Serial Interface Inside Clock Source**

	Serial 2
Clock source (Internal clock)	fosc/2
	fosc/4
	fosc/16
	fosc/32
	fs/2
	fs/4
	timer 3 output

 When timer output is selected as serial interface transfer clock, select fosc as a clock source of the timer. If other clock is selected, normal transfer of serial interface data is not guaranteed.

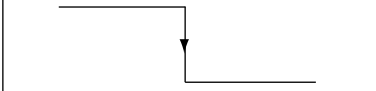
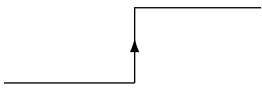
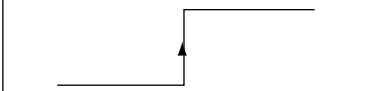
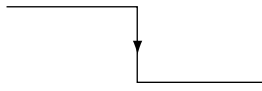
■BUSY flag Setup

If data is set to the transmit/receive shift register SC2TRB, or start condition is enabled, the busy flag SC2BSY is set. That is cleared by the generation of the communication complete interrupt SC2IRQ.

■Input edge / output edge Setup

The SC2CE1 flag of the SC2MD0 register can set the output edge of the transmission data, and the input edge of the received data. Data at transmission is output at the falling edge of clock as the SC2CE1 flag = "0", and at the rising edge of clock as the SC2CE1 = "1". Data at reception is input at the rising edge of clock as the SC2CE1 = "0", and at the falling edge of clock as the SC2CE1 flag = "1".

**Table 13-3-3 Input Edge / Output Edge of Transmission and Received Data**

SC2CE1	Transmission data output edge	Received data input edge
0		
1		

### ■Data Input Pin Setup

There are 2 communication modes to be selected : 3 channels (clock pin(SBT2 pin), data output pin (SBO2 pin), data input pin (SBI2 pin)), 2 channels (clock pin (SBT2 pin), data I/O pin (SBO2 pin)). The SBI2 pin can be used only for serial data input. The SBO2 pin can be selected for serial data input or output. The SC2IOM flag of the SC2MD1 register can specify if serial data is input from the SBI2 pin, or the SBO2 pin. When "data input from the SBO2 pin" is selected to communicate with 2 channels, the SBO2 pin's direction control by the P0DIR3 flag of the P0DIR register can switch the transmission / reception. At that time, the SBI2 pin is not used, so that it can be used as a general port.



The transfer speed can be up to 2.5 MHz. If the transfer clock is more than 2.5 MHz, the transmission data may be output correctly.

### ■Forced Reset for Communication

It is possible to shut down the communication. A forced reset is done by setting both of the SC2SBOS flag and the SC2SBIS flag of the SC2MD1 register to "0" (the SBO2 pin function : port, input data : input "1"). When a forced reset is done, the SC2BSY flag of the SC2MD0 register is cleared, but other control registers hold their set values.

### ■Last Bit of Transmission Data

Table 13-3-4 shows the data output holding period of the last bit at transmission, and the minimum data input period of the last bit at reception. At slave, setup for the internal clock is needed to keep data holding time at data transmission. After the last bit data output holding period, "H" is output.

**Table 13-3-4 Last Bit Data Length of Transmission Data**

	at transmission Last bit data holding period	at reception Last bit data input period
at master	1 bit data length	1 bit data length (minimum)
at slave	[1 bit data length of external clock x 1/2] + [internal clock cycle x (1/2 to 1) ]	

■ Transmission Timing

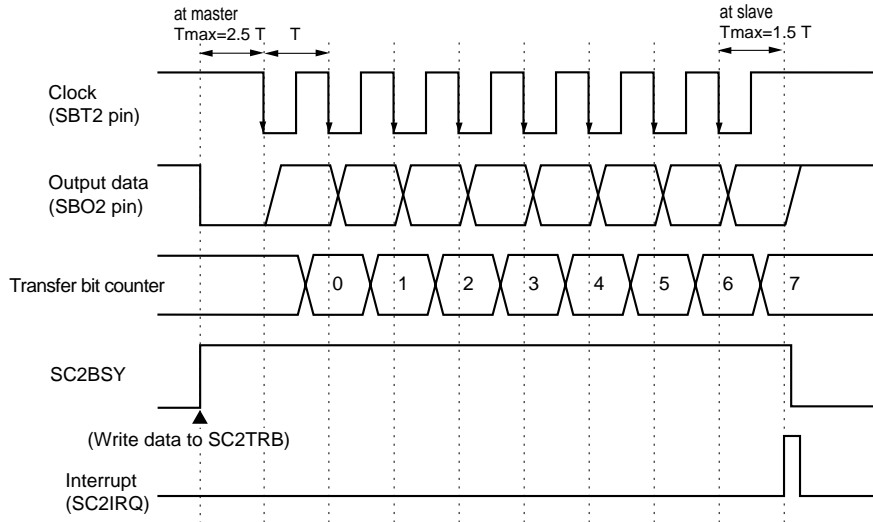


Figure 13-3-2 Transmission Timing (Falling edge, Start condition is enabled)

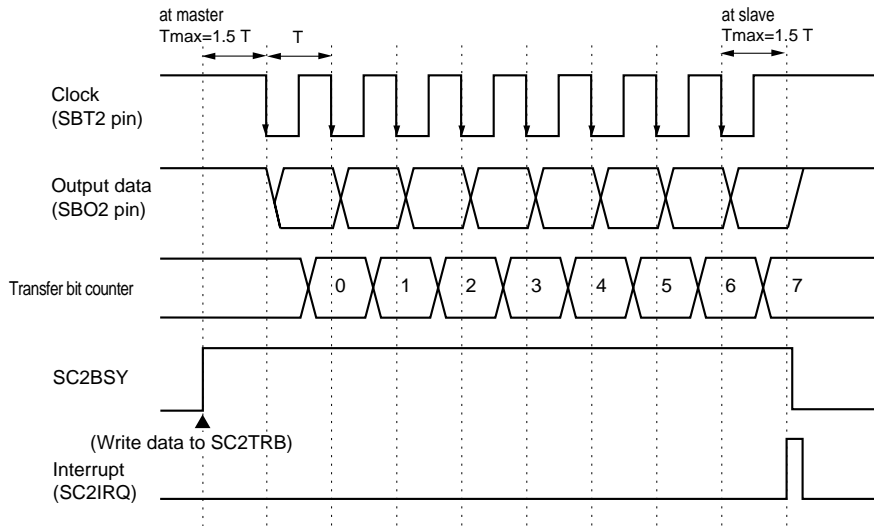
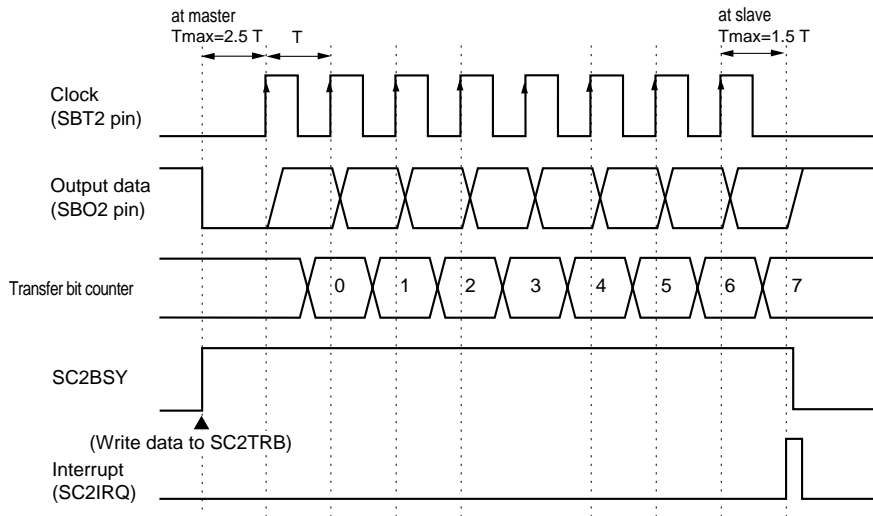
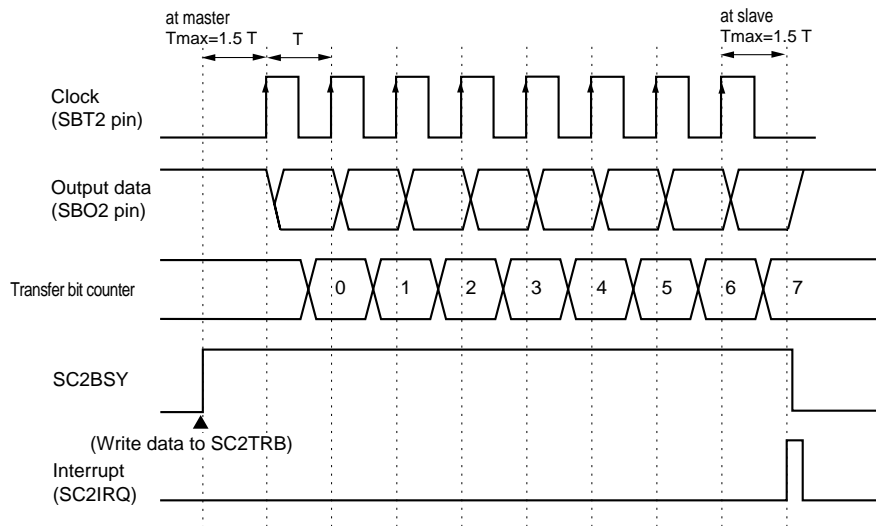


Figure 13-3-3 Transmission Timing (Falling edge, Start condition is disabled)



**Figure 13-3-4 Transmission Timing (Rising edge, Start condition is enabled)**



**Figure 13-3-5 Transmission Timing (Rising edge, Start condition is disabled)**

■ Reception Timing

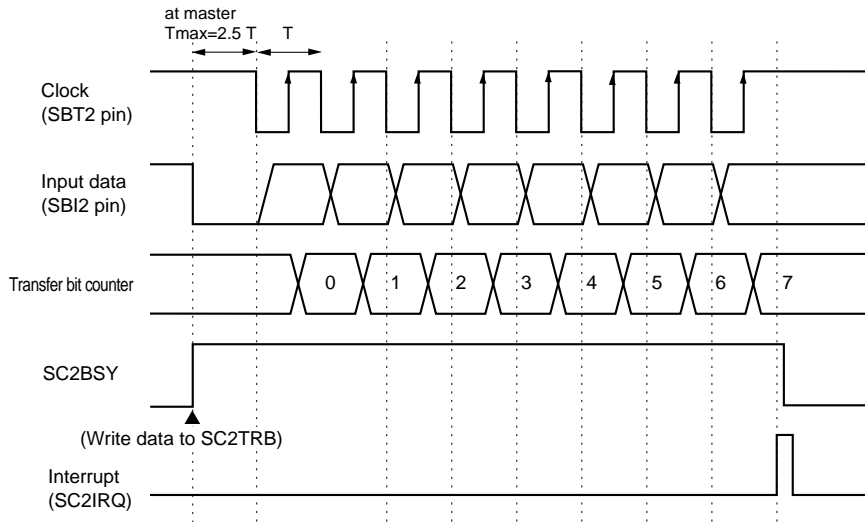


Figure 13-3-6 Reception Timing (Rising edge, Start condition is enabled)

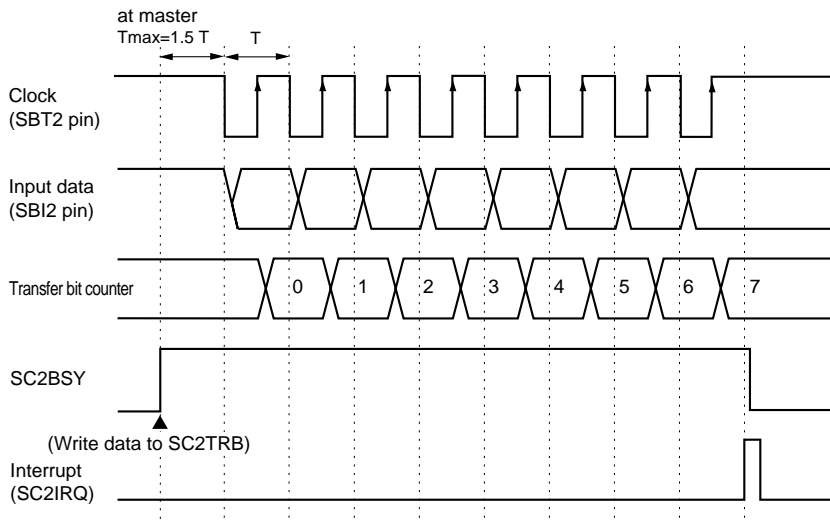
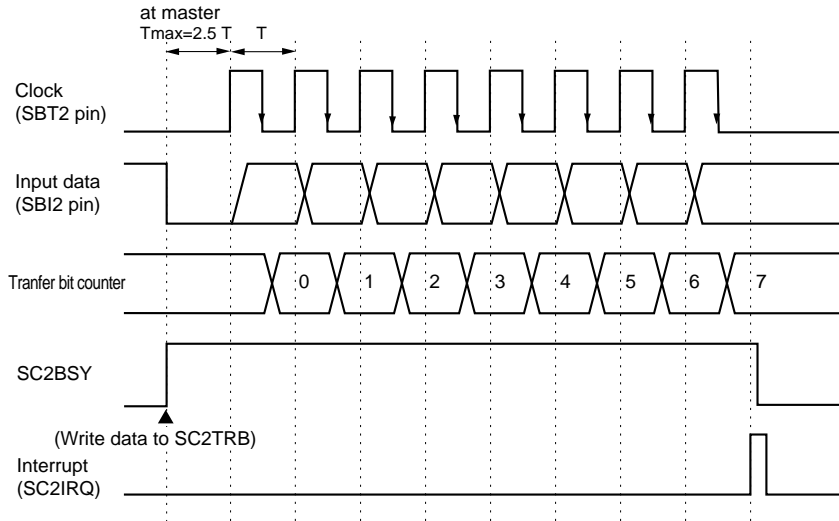
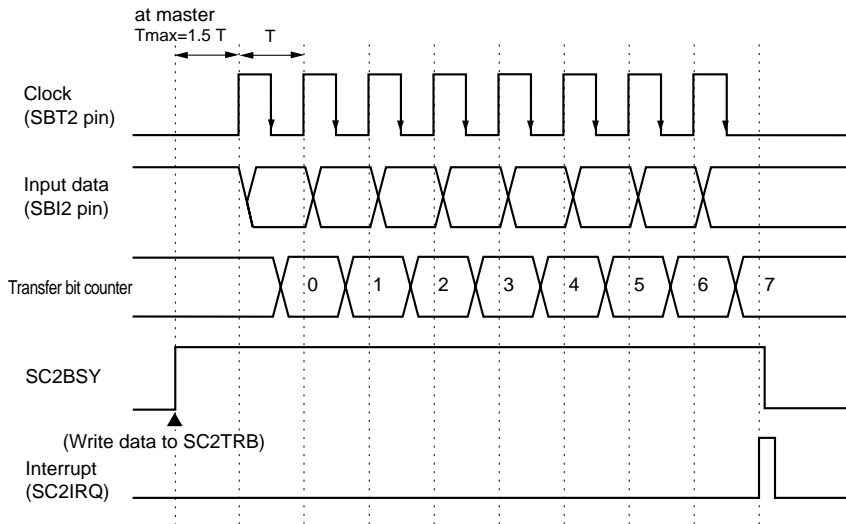


Figure 13-3-7 Reception Timing (Rising edge, Start condition is disabled)



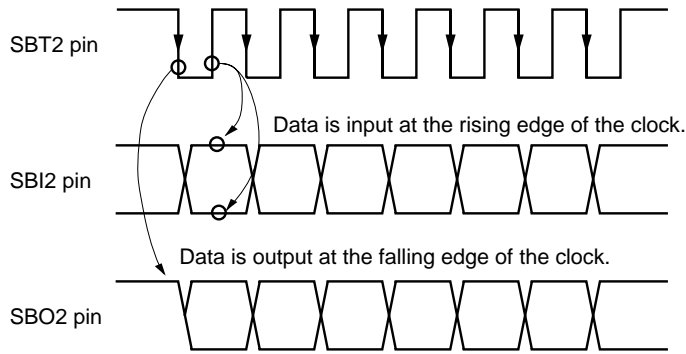
**Figure 13-3-8 Reception Timing (Falling edge, Start condition is enabled)**



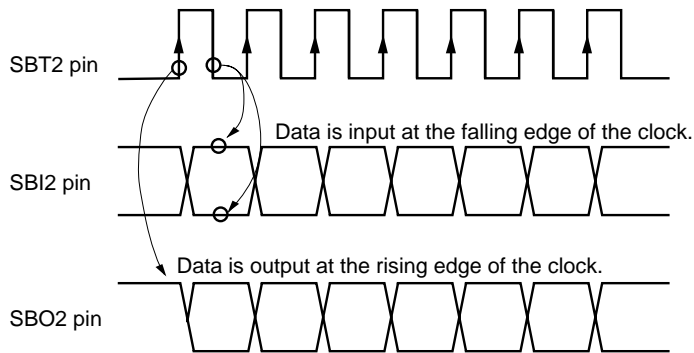
**Figure 13-3-9 Reception Timing (Falling edge, Start condition is disabled)**

■ Transmission / Reception

When transmission and reception are operated at the same time, data is received at the opposite edge of the transmission clock.



**Figure 13-3-10 Transmission / Reception Timing  
(Reception : Rising edge, Transmission : Falling edge)**



**Figure 13-3-11 Transmission / Reception Timing  
(Reception : Falling edge, Transmission : Rising edge)**



■ Pins Setup (3 channels, at transmission)

Figure 13-3-5 shows the pins setup at synchronous serial interface transmission with 3 channels (SBO2 pin, SBI2 pin, SBT2 pin).

**Figure 13-3-5 Synchronous Serial Interface Pins Setup (3 channels, at transmission)**

Item	Data output pin	Data input pin	Clock I/O pin	
	SBO2 pin	SBI2 pin	SBT2 pin	
			Internal clock	External clock
Pin	P03	P04	P05	
SBI2/SBO2 pin	SBI2/SBO2 independent		-	
	SC2MD1(SC2IOM)			
Function	Serial data output	Input "1"	Serial clock I/O	Serial clock I/O
	SC2MD1(SC2SBOS)	SC2MD1(SC2SBIS)	SC2MD1(SC2SBTS)	
Type	Push-pull/ N-ch open-drain	-	Push-pull/ N-ch open-drain	Push-pull/ N-ch open-drain
	SC2ODC(SC2ODC0)		SC2ODC(SC2ODC1)	
I/O	Output mode	-	Output mode	Input mode
	P0DIR(P0DIR3)		P0DIR(P0DIR5)	
Pull-up	added / not added	-	added / not added	added / not added
	P0PLU(P0PLU3)		P0PLU(P0PLU5)	

■ Pins Setup (3 channels, at reception)

Figure 13-3-6 shows the pins setup at synchronous serial interface reception with 3 channels (SBO2 pin, SBI2 pin, SBT2 pin).

**Figure 13-3-6 Synchronous Serial Interface Pins Setup (3 channels, at reception)**

Item	Data output pin	Data input pin	Clock I/O pin	
	SBO2 pin	SBI2 pin	SBT2 pin	
			Internal clock	External clock
Pin	P03	P04	P05	
SBI2/SBO2 pins	SBI2/SBO2 independent		-	
	SC2MD1(SC2IOM)			
Function	Port	Serial data input	Serial clock I/O	Serial clock I/O
	SC2MD1(SC2SBOS)	SC2MD1(SC2SBIS)	SC2MD1(SC2SBTS)	
Type	-	-	Push-pull/ N-ch open-drain	Push-pull/ N-ch open-drain
			SC2ODC(SC2ODC1)	
I/O	-	Input mode	Output mode	Input mode
		P0DIR(P0DIR4)	P0DIR(P0DIR5)	
Pull-up	-	-	added / not added	added / not added
			P0PLU(P0PLU5)	

■ Pins Setup (3 channels, at reception / transmission)

Figure 13-3-7 shows the pins setup at synchronous serial interface transmission/reception with 3 channels (SBO2 pin, SBI2 pin, SBT2 pin).

**Figure 13-3-7 Synchronous Serial Interface Pins Setup  
(3 channels, at transmission / reception)**

Item	Data output pin	Data input pin	Clock I/O pin	
	SBO2 pin	SBI2 pin	SBT2 pin	
			Internal clock	External clock
Pin	P03	P04	P05	
SBI2/SBO2 pins	SBI2/SBO2 independent		-	
	SC2MD1(SC2IOM)			
Function	Serial data output	Serial data input	Serial clock I/O	Serial clock I/O
	SC2MD1(SC2SBOS)	SC2MD1(SC2SBIS)	SC2MD1(SC2SBTS)	
Type	Push-pull/ N-ch open-drain	-	Push-pull/ N-ch open-drain	Push-pull/ N-ch open-drain
	SC2ODC(SC2ODC0)		SC2ODC(SC2ODC1)	
I/O	Output mode	Input mode	Output mode	Input mode
	P0DIR(P0DIR3)	P0DIR(P0DIR4)	P0DIR(P0DIR5)	
Pull-up	added / not added	-	added / not added	added / not added
	P0PLU(P0PLU3)		P0PLU(P0PLU5)	

■ Pins Setup (2 channels, at transmission)

Figure 13-3-8 shows the pins setup at synchronous serial interface transmission with 2 channels (SBO2 pin, SBT2 pin). The SBI2 pin is not used, so that it can be used as a general port.

**Figure 13-3-8 Synchronous Serial Interface Pins Setup (2 channels, at transmission)**

Item	Data I/O pin	Serial unused pin	Clock I/O pin	
	SBO2 pin	SBI2 pin	SBT2 pin	
			Internal clock	External clock
Pin	P03	P04	P05	
SBI2/SBO2 pins	SBI2/SBO2 connection		-	
	SC2MD1(SC2IOM)			
Function	Serial data output	input "1"	Serial clock I/O	Serial clock I/O
	SC2MD1(SC2SBOS)	SC2MD1(SC2SBIS)	SC2MD1(SC2SBTS)	
Type	Push-pull/ N-ch open-drain	-	Push-pull / N-ch open-drain	Push-pull / N-ch open-drain
	SC2ODC(SC2ODC0)		SC2ODC(SC2ODC1)	
I/O	Output mode	-	Output mode	Input mode
	P0DIR(P0DIR3)		P0DIR(P0DIR5)	
Pull-up	added / not added	-	added / not added	added / not added
	P0PLU(P0PLU3)		P0PLU(P0PLU5)	

■ Pins Setup (2 channels, at reception)

Figure 13-3-9 shows the pins setup at synchronous serial interface reception with 2 channels (SBO2 pin, SBT2 pin). The SBI2 pin is not used, so that it can be used as a general port.

**Figure 13-3-9 Synchronous Serial Interface Pins Setup (2 channels, at reception)**

Item	Data I/O pin	Serial unused pin	Clock I/O pin	
	SBO2 pin	SBI2 pin	SBT2 pin	
			Internal clock	External clock
Pin	P03	P04	P05	
SBI2/SBO2 pins	SBI2/SBO2 connection		-	
	SC2MD1(SC2IOM)			
Functions	Port	Serial data input	Serial clock I/O	Serial clock I/O
	SC2MD1(SC2SBOS)	SC2MD1(SC2SBIS)	SC2MD1(SC2SBTS)	
Type	-	-	Push-pull / N-ch open-drain	Push-pull / N-ch open-drain
			SC2ODC(SC2ODC1)	
I/O	Input mode	-	Output mode	Input mode
	P0DIR(P0DIR3)		P0DIR(P0DIR5)	
Pull-up	-	-	added / not added	added / not added
			P0PLU(P0PLU5)	

## 13-3-2 Setup Example

### ■Transmission / Reception Setup Example


Here is the setup example at transmission/reception with serial interface 2. Figure 13-3-10 shows the conditions.

**Figure 13-3-10 Conditions for Synchronous Serial Interface at transmission / reception)**

Item	set to	Item	set to
SBI2 / SBO2 pins	independent (with 3 channels)	clock	Internal clock
Transfer bit count	8 bits	clock source	fs/2
Start condition	enable	SBT2 / SBO2 pin type	N-ch open- drain
First bit to be transfered	MSB	SBT2 pin pull-up resistance	added
Input clock edge	at falling	SBO2 pin pull-up resistance	added
Output clock edge	at rising	Serial 2 interrupt	generate

An example setup procedure, with a description of each step is shown below.

Setup Procedure	Description
(1) Select prescaler operation. PSCMD (x'3F6F') bp0 : PSCEN = 1	(1) Set the PSCEN flag of the PSCMD register to "1" to select prescaler operation.
(2) Select the clock source. SC2CKS (x'3FA7') bp2-0 : SC2PSC2-0 = 100 bp3 = 0	(2) Set the SC2PSC2-0 flag of the SC2CKS register to "100" to select fs/2 at clock source. Set bp3 of the SC2CKS register to "0", always.
(3) Control the pin type. SC2ODC (x'3F46') bp1-0 : SC2ODC1-0 = 11 POPLU (x'3F40') bp5, 3 : POPLU5, 3 = 1, 1	(3) Set the SC2ODC1-0 flag of the SC2ODC register to "11" to select N-ch open drain for the SBO2/SBT2 pin type. Set the POPLU5, 3 flag of the POPLU register to "1, 1" to add pull-up resistor.
(4) Control the pin direction. P0DIR (X'3F30') bp5-3 : P0DIR5-3 = 101	(4) Set the P0DIR5-3 flag of the port 0 pin control direction register (P0DIR) to "101" to set P05, P03 to output mode, to set P04 to input mode.
(5) Set the SC2MD0 register. Select the transfer bit count. SC2MD0 (x'3FA0') bp2-0 : SC2LNG2-0 = 111	(5) Set the SC2LNG2-0 flag of the serial 2 mode register (SC2MD0) to "111" to set the transfer bit count to 8 bits.

Setup Procedure	Description
Select the start condition. SC2MD0 (x'3FA0') bp3 : SC2STE = 1	Set the SC2STE flag of the SC2MD0 register to "1" to enable start condition.
Select the first bit to be transferred. SC2MD0 (x'3FA0') bp4 : SC2DIR = 0	Set the SC2DIR flag of the SC2MD0 register to "0" to set MSB as the first transfer bit.
Select the transfer edge. SC2MD0 (x'3FA0') bp6 : SC2CE1 = 1	Set the SC2CE1 flag of the SC2MD0 register to "1" to set the transmission data output edge to "rising", and the received data input edge to "falling".
(6) Set the SC0MD2 register. Select the transfer clock. SC2MD1 (x'3FA1') bp2 : SC2MST = 1	(6) Set the SC2MST flag of the SC2MD1 register to "1" to select clock master (internal clock).
Control the pin function. SC2MD1 (x'3FA1') bp4 : SC2SBOS = 1 bp5 : SC2SBIS = 1 bp6 : SC2SBTS = 1 bp7 : SC2IOM = 0	Set the SC2SBOS, SC2SBIS, SC2SBTS flags of the SC2MD1 register to "1" to set the SBO2 pin to serial data output, the SBI2 pin to serial data input, and the SBT2 pin to serial clock I/O. Set the SC2IOM flag to "0" to set "serial data input from the SBI2 pin".
(7) Set the interrupt level. SC2ICR (x'3FF8') bp7-6 : SC2LV1-0 = 10	(7) Set the interrupt level by the SCLV1-0 flag of the serial 2 interrupt control register (SC2ICR).
(8) Enable the interrupt. SC2ICR (x'3FF8') bp1 : SC2IE = 1	(8) Enable the interrupt to the SC2IE flag of the SC2ICR register. If the interrupt request flag (SC2IR of the SC2ICR register) is already set, clear SC2IR before the interrupt is enabled. [  Chapter 3 3-1-4. Interrupt Flag Setup ]
(9) Start serial transmission. Transmission data → SC2TRB (x7'3FA2')	(9) Set the transmission data to the serial transmit/receive shift register SC2TRB. The internal clock is generated to start transmission/reception. After the communication is finished, the serial 2 interrupt SC2IRQ is generated.

Note : In the above (5) and (6), each settings can be set at once.



If the communication is only for transmission, the data that input by setting the SC2SBIS of the SC2MD1 register to "0" should be fixed to "1". The SBI2 pin can be used as a general port.



If the communication is only for reception, set the SC2SBOS of the SC2MD1 register to "0" to select port. The SBO2 pin can be used as a general port.



If the communication is with 2 channels connected the SBO2/SBI2 pins, the SBO2 pin inputs/outputs serial data. The port direction control register PDIR switches I/O.



It is possible to shut down the communication. When the communication should be stopped by force, set the SC2SBOS and the SC2SBIS of the SC2MD1 register to "0".



Setup for each flag should be done in order. The activation of communication should be operated after all control registers (except table 13-2-1 : SC2TRB) are set.



The SC2CKS register should set the transfer rate of the transfer clock to "under 2.5 MHz".



When timer output is selected as serial interface transfer clock, select fosc as a clock source of the timer. If other clock is selected, normal transfer of serial interface data is not guaranteed.






## 14-1 Overview

This LSI contains a serial interface 3 can be used for both communication types of clock synchronous and simple IIC (single master).

### 14-1-1 Functions

Table 14-1-1 shows the functions of serial interface 3.

**Table 14-1-1 Serial Interface 3 Functions List**

Communication type	Clock synchronous	IIC (single master)
Interrupt	SC3IRQ	SC3IRQ
Pin	SBO3, SBI3, SBT3	SDA, SCL
3 channels type	√	-
2 channels type	√(SBO3, SBT3)	√
Start condition	√	√
Transfer bit count	1 to 8 bit	1 to 8 bit
First transfer bit	√	√
Input edge / Output edge	√	-
ACK bit	-	√
ACK bit level	-	√
Continuous operation (with ATC1)	√	-
Clock source	fosc/2 fosc/4 fosc/16 fosc/32 fs/2 fs/4 timer 3 output external clock	fosc/2 fosc/4 fosc/16 fosc/32 fs/2 fs/4 timer 3 output
Maximum transfer rate	2.5 MHz	400 kHz
fosc : machine clock (high speed oscillation) fs : system clock [  Chapter 2 2-5. Clock Switching ] At IIC communication, the transfer clock is the clock source divided by 3.		

## 14-1-2 Block Diagram

### Serial Interface 3 Block Diagram

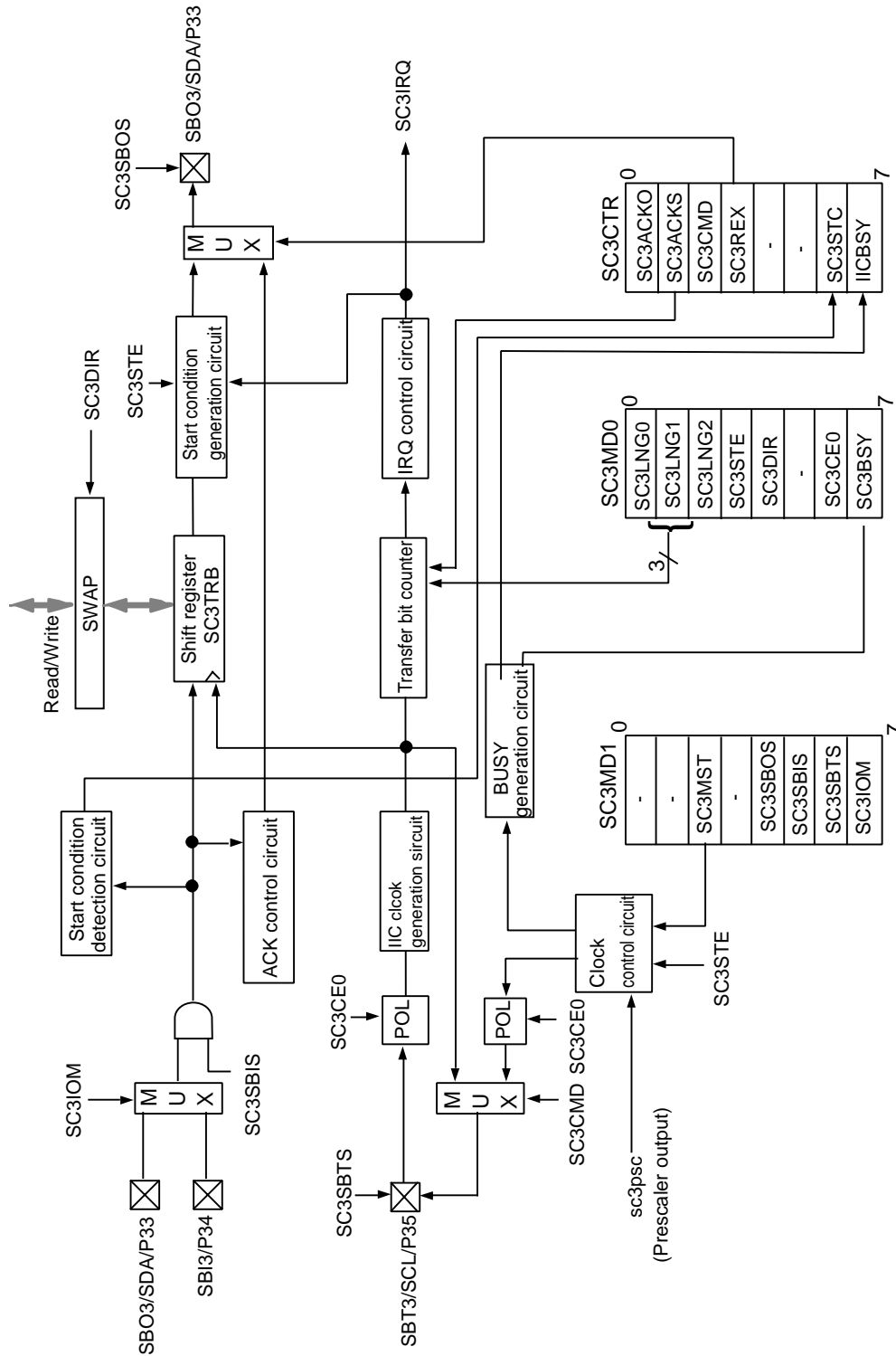


Figure 14-1-1 Serial Interface 3 Block Diagram

## 14-2 Control Registers

### 14-2-1 Registers

Table 14-2-1 shows the registers to control serial interface 3.

**Table 14-2-1 Serial Interface 3 Control Registers**

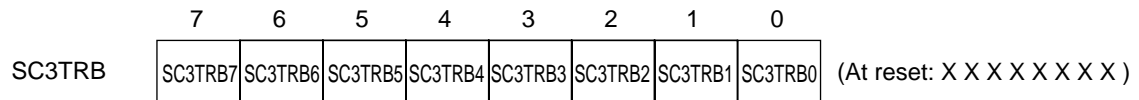
	Register	Address	R/W	Function	Page
Serial interface 3	SC3MD0	x'03FA8'	R/W	Serial interface 3 mode register 0	XIV - 6
	SC3MD1	x'03FA9'	R/W	Serial interface 3 mode register 1	XIV - 7
	SC3CTR	x'03FAA'	R/W	Serial interface 3 control register	XIV - 8
	SC3TRB	x'03FAB'	R/W	Serial interface 3 transmit/receive shift register	XIV - 5
	SC3ODC	x'03FAE'	R/W	Serial interface 3 port control register	XIV - 9
	SC3CKS	x'03FAF'	R/W	Serial interface 3 transfer clock selection register	XIV - 9
	PSCMD	x'03F6F'	R/W	Prescaler control register	V - 6
	P3DIR	x'03F33'	R/W	Port 3 direction control register	IV - 23
	P3PLU	x'03F43'	R/W	Port 3 pull-up control register	IV - 23
	SC3ICR	x'03FF9'	R/W	Serial interface 3 interrupt control register	III - 37

R / W : Readable / Writable

## 14-2-2 Data Register

Serial interface 3 has a 8-bit serial data register.

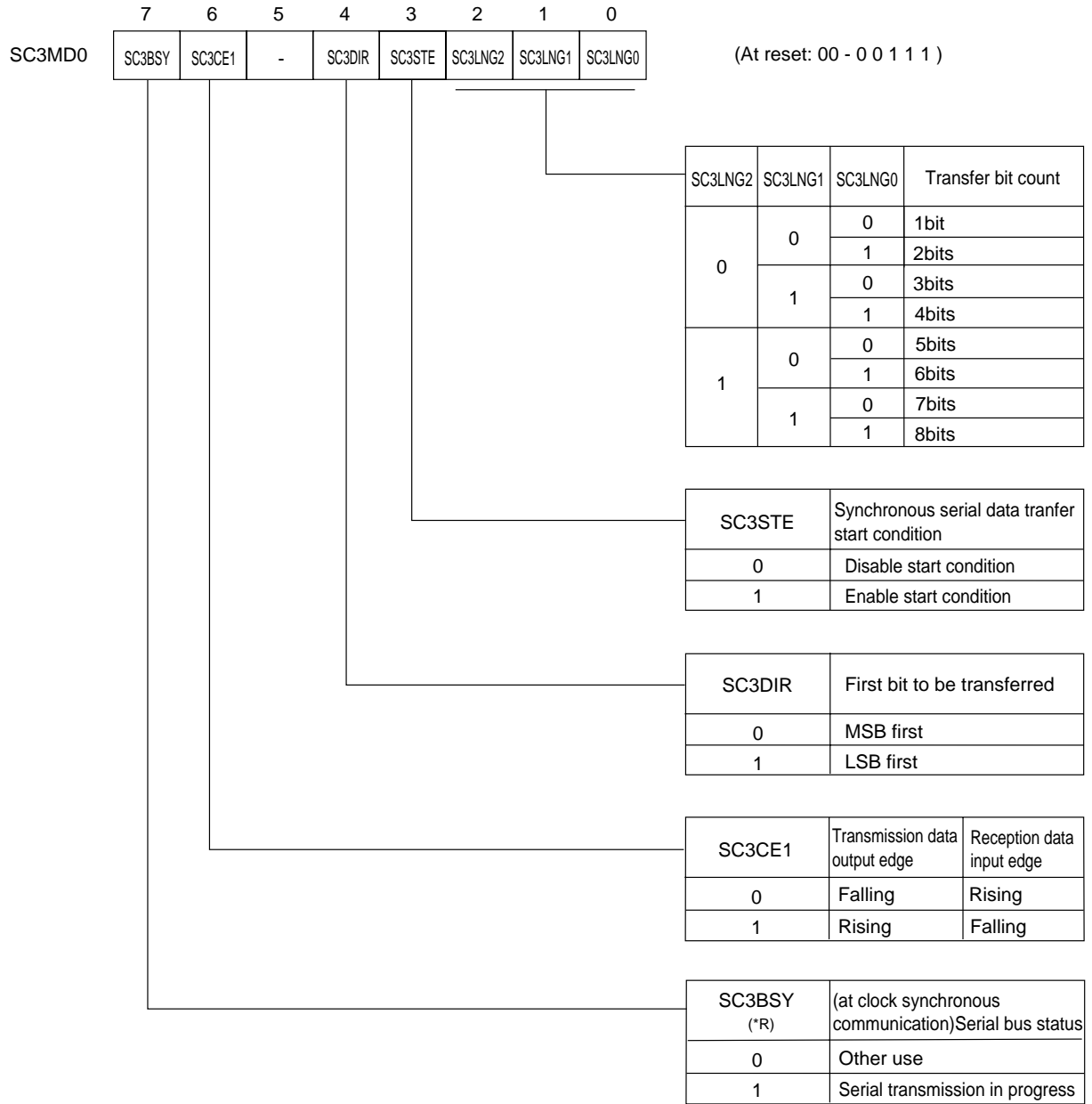
### ■ Serial Interface 3 Transmit / Receive Shift Register (SC3TRB)



**Figure 14-2-1 Serial Interface 3 Transmit/Receive Shift Register (SC3TRB : x'03FAB', R/W)**

### 14-2-3 Mode Registers

■Serial Interface 3 Mode Register 0 (SC3MD0)



\* Only read access is available.

Figure 14-2-2 Serial Interface 3 Mode Register 0 (SC3MD0 : x'03FA8', R/W)

■ Serial Interface 3 Mode Register 1 (SC3MD1)

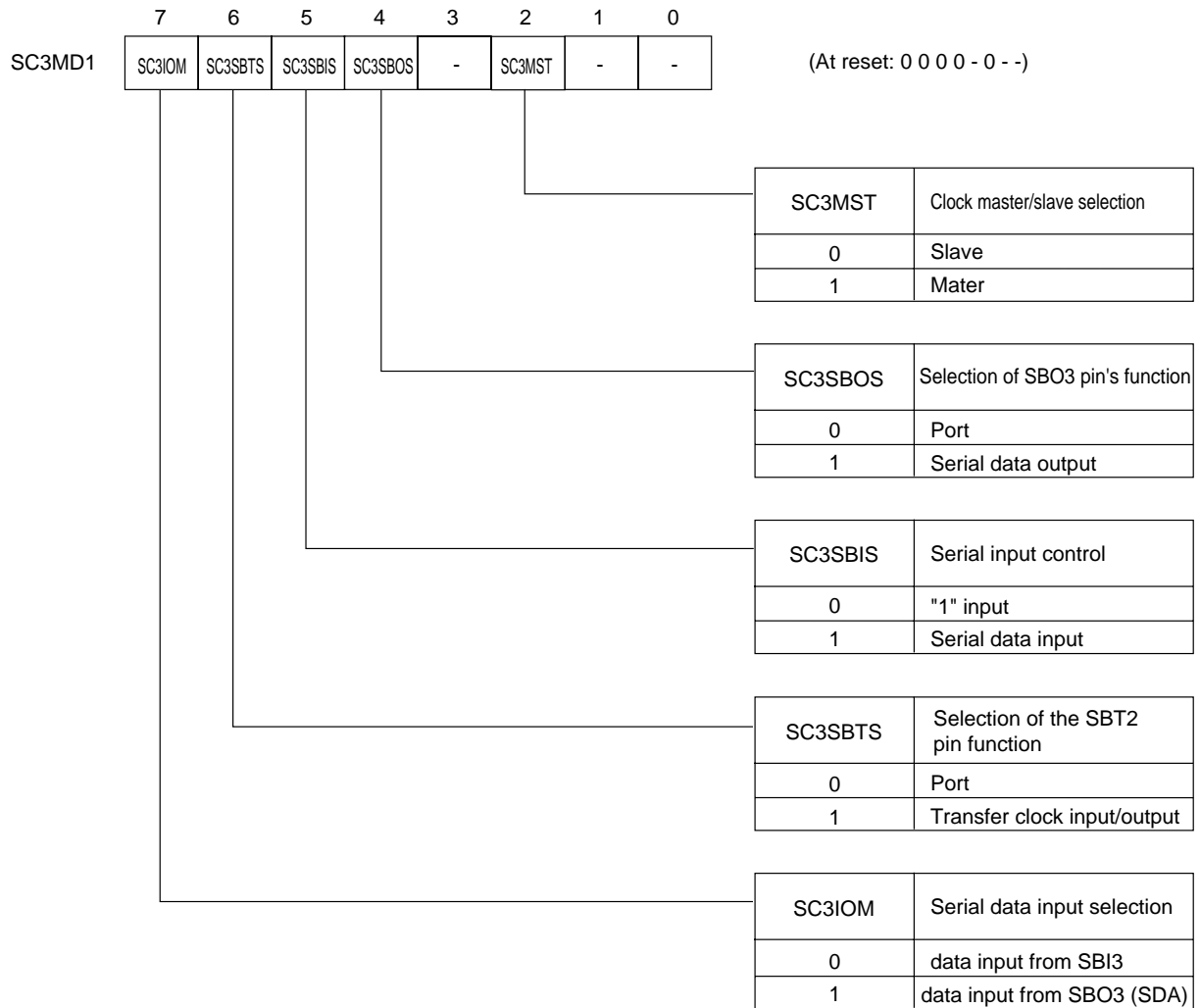


Figure 14-2-3 Serial Interface 3 Mode Register 1 (SC3MD1 : x'03FA9', R/W)

■Serial Interface 3 Control Register (SC3CTR)

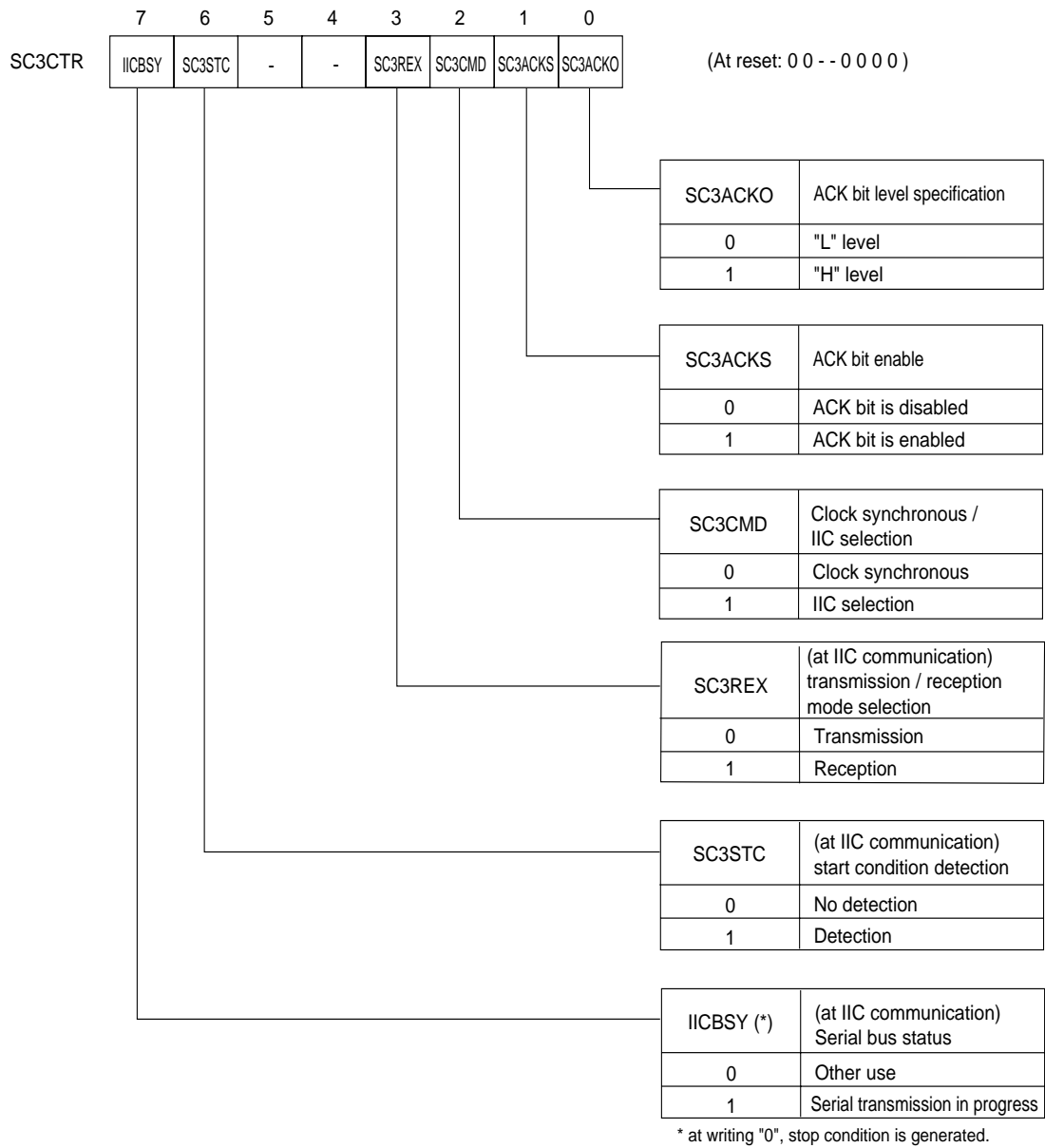


Figure 14-2-4 Serial Interface 3 Control Register (SC3CTR : x'03FAA', R/W)



■Serial Interface 3 Port Control Register (SC3ODC)

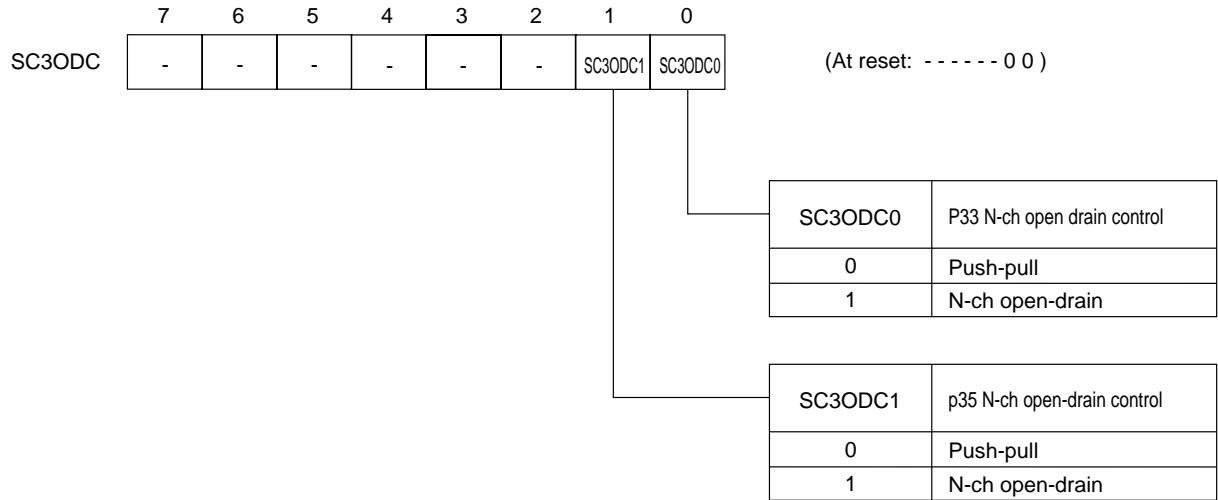


Figure 14-2-5 Serial Interface 3 Port Control Register (SC3ODC : x'03FAE', R/W)

■Serial Interface 3 Transfer Clock Selection Register (SC3CKS)

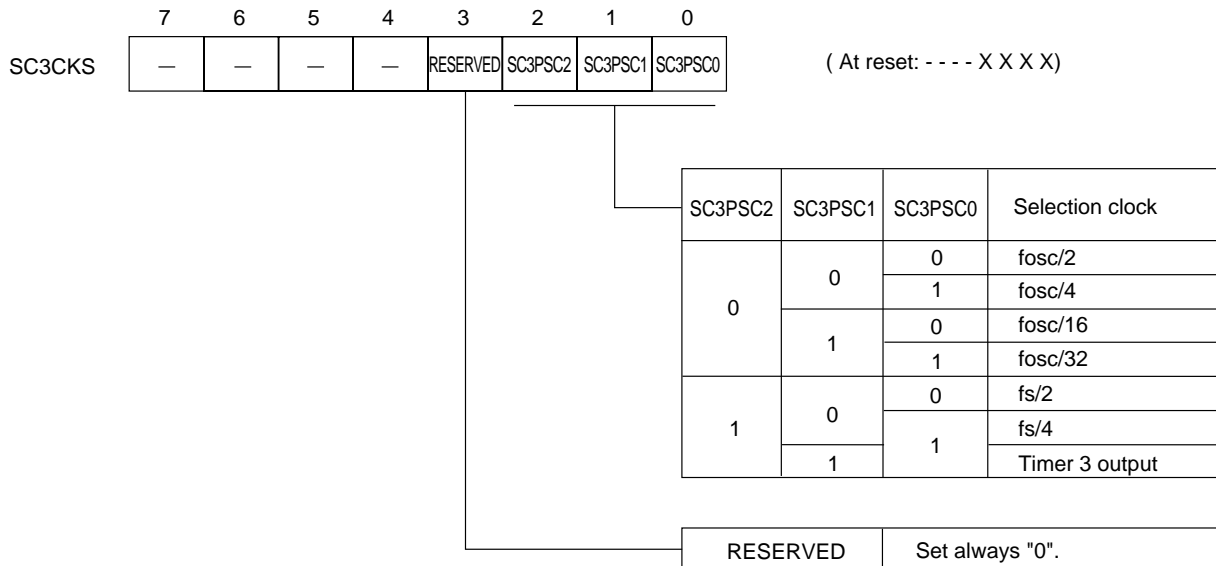



Figure 14-2-6 Serial Interface 3 Transfer Clock Selection Register (SC3CKS : x'03FAF', R/W)

 When timer output is selected as serial interface transfer clock, select fosc as a clock source of the timer. If other clock is selected, normal transfer of serial interface data is not guaranteed.

## 14-3 Operation

This LSI contains a serial interface 3 that can be used for both communication types of clock synchronous and single master IIC.

### 14-3-1 Clock Synchronous Serial Interface

#### ■Activation Factor for Communication

Table 14-3-1 shows the activation factor for communication. At master communication, the transfer clock is generated by setting data to the transmit/receive shift register SC3TRB, or by receiving start condition. The input signal from the SBT3 pin is masked inside of serial interface to prevent errors by noise except during communication. This mask is automatically released by setting data to SC3TRB (writing data to the SC3TRB register), or by inputting start condition to the data input pin. Therefore, at slave, input the external clock after setting data to SC3TRB, or by inputting start condition.

**Table 14-3-1 Activation factor of Synchronous Serial Interface**

	Activation factor	
	transmission	reception
at master	Set transmission data	Set dummy data
		Input start condition
at slave	Input clock after transmission data is set	Input clock after dummy data is set
		Input clock after start condition is input

#### ■Transfer Bit Count Setup

The transfer bit count can be selected from 1 bit to 8 bits. Set it by the SC3LNG 2 to 0 flag of the SC3MD0 register (at reset : 111). The SC3LNG2 to 0 flag holds the previous set values till it is set again.



The SBT3 pin is masked inside serial to prevent errors by noise. At slave, input clock to the SBT3 pin after start condition is input or data is set to SC3TRB.

#### ■Start Condition Setup

Start condition can be selected if it is enabled or not. Set by the SC3STE flag of the SC3MD0 register. When start condition is enabled, the transfer bit counter is cleared as start condition is input during communication, and after that, the communication is automatically started again. Start condition is enabled as data line (the SBI3 pin (with 3 channels) or the SBO3 pin (with 2 channels)) is changed from "H" to "L", when clock line (the SBT3 pin) is "H".

### ■First Transfer Bit Setup

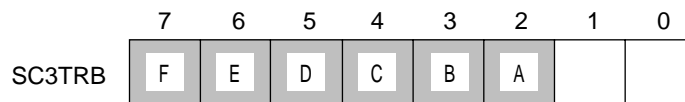
The first bit to be transferred can be set by the SC3DIR flag of the SC3MD0 register. MSB first or LSB first can be selected.

### ■Transmit /Receive Data Buffer

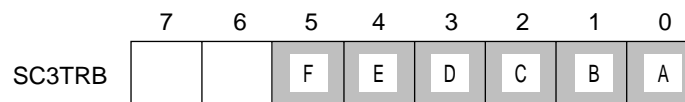
Data register for transmission/reception is common. That is the transmit/receive shift register SC3TRB. The transmission data should be set to SC3TRB. The transfer clock outputs data by 1 bit in shift. The received data is stored to SC3TRB by 1 bit in shift.

### ■Transfer Bit Count and First Transfer Bit

At transmission, when the transfer bit count is 1 to 7 bits, data storage way to the transmit/receive shift register SC3TRB depends on the first transfer bit selection. When MSB is the first bit to be transferred, use the upper bits of SC3TRB for storage. In figure 14-3-1-1, if data "A" to "F" are stored to bp2 to bp7 of SC3TRB as the transfer bit count is 6 bits, data is transferred from "F" to "A". When LSB is the first bit to be transferred, use the lower bits of SC3TRB for storage. In figure 14-3-1-2, if data "A" to "F" are stored to bp0 to bp5 of SC3TRB, as the transfer bit count is 6 bits, data is transferred from "A" to "F".



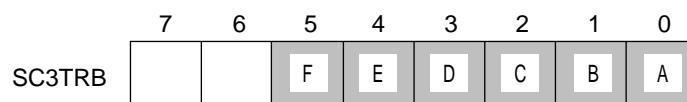
**Figure 14-3-1-1 Transfer Bit Count and First Transfer Bit (at MSB first)**



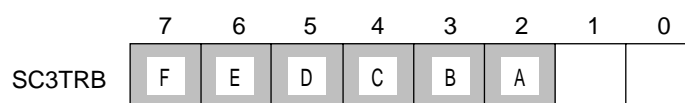
**Figure 14-3-1-2 Transfer Bit Count and First Transfer Bit (at LSB first)**

### ■Receive Bit Count and First Transfer Bit

At reception, when the transfer bit count is 1 to 7 bits, data storage way to the transmit/receive shift register SC3TRB depends on the first transfer bit selection. When MSB is the first bit to be transferred, the lower bits of SC3TRB are used for storage. In figure 14-3-1-3, as the transfer bit count is 6 bits, data "A" to "F" are stored to bp0 to bp5 of SC3TRB, and they are transferred from "F" to "A". When LSB is the first bit to be transferred, use the upper bits of SC3TRB for storage. In figure 14-3-1-4, data "A" to "F" are stored to bp2 to bp7 of SC3TRB, as the transfer bit count is 6 bits, and they are transferred from "A" to "F".



**Figure 14-3-1-3 Receive Bit Count and First Transfer Bit (at MSB first)**



**Figure 14-3-1-4 Receive Bit Count and First Transfer Bit (at LSB first)**

■Continuous Communication

Serial interface 3 can be started by automatic data transfer function ATC1, built-in this LSI. If ATC1 is used for activation, data can be continuously transferred up to 255 byte. The communication blank, from the generation of the communication complete interrupt SC3IRQ to the generation of the next transfer clock, is up to 18 machine cycles + 2 transfer clocks. For activation by ATC1, refer to chapter 15 Automatic Transfer Controller, Transfer mode 6 to 7.



If start condition is input for activation again, during communication, the transmission data becomes invalid. If the transmission should be operated again, set the transmission data to SC3TRB, again.

■Clock Setup

Clock source is selected from the dedicated prescaler by the SC3CKS register and timer 3 output. The dedicated prescaler is started by selecting "prescaler operation" by the PSCMD (x'03F6F') register. The SC3MST flag of the SC3MD1 register can select the internal clock (clock master), or the external clock (clock slave). Even if the external clock is selected, the internal clock with same frequency to the external clock, should be set by the SC3CKS register, because the internal clock generates the interrupt flag SC3IRQ. Table 14-3-2 shows the internal clock source which can be set by the SC3CKS register.

**Table 14-3-2 Synchronous Serial Interface Internal Clock Source**

Communication type	Clock synchronous
Clock source (internal clock)	fosc/2
	fosc/4
	fosc/16
	fosc/32
	fs/2
	fs/4
	timer 3 output



When timer output is selected as serial interface transfer clock, select fosc as a clock source of the timer. If other clock is selected, normal transfer of serial interface data is not guaranteed.

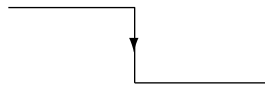
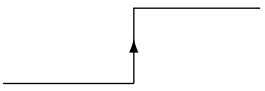
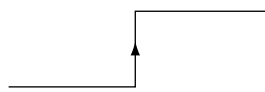
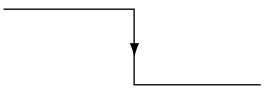
■BUSY Flag

If data is set to the transmit/receive shift register SC3TRB, or start condition is enabled, the busy flag SC3BSY is set. That is cleared by the generation of the communication complete interrupt SC3IRQ.

■Input edge/Output edge Setup

The SC3CE1 flag of the SC3MD0 register can set the output edge of the transmission data, and the input edge of the received data. Data at transmission is output at the falling edge of clock as the SC3CE1 flag = "0", and at the rising edge of clock as the SC3CE1 = "1". Data at reception is input at the rising edge of clock as the SC3CE1 = "0", and at the falling edge of clock as the SC3CE1 flag = "1".

**Table 14-3-3 Input Edge/Output Edge of Transmission/Received Data**

SC3CE1	Transmission data output edge	Received data input edge
0		
1		

#### ■Data Input Pin Setup

There are 2 communication modes to be selected : 3 channels type (clock pin(SBT3 pin), data output pin (SBO3 pin), data input pin (SBI3 pin)), 2 channels type (clock pin (SBT3 pin), data I/O pin (SBO3 pin)). The SBI3 pin can be used only for serial data input. The SBO3 pin can be used for serial data input or output. The SC3IOM flag of the SC3MD1 register can specify if serial data is input from the SBI3 pin, or the SBO3 pin. When "data input from the SBO3 pin" is selected to communicate with 2 channels, the SBO3 pin's direction control by the P3DIR3 flag of the P3DIR register can switch the transmission / reception. At that time, the SBI3 pin is not used, so that it can be used as a general port.

#### ■Forced Reset at Communication

It is possible to shut down the communication. A forced reset is operated by setting both of the SC3SBOS flag and the SC3SBIS flag of the SC3MD1 register to "0" (the SBO3 pin function : port, input data : input "1"). When a forced reset is operated, the SC3BSY flag of the SC3MD0 register, and the IICBSY flag of the SC3CTR register are cleared, but other control registers hold their set values.

#### ■Last Bit of Transfer Data

Table 14-3-4 shows the data output holding period of the last bit at transmission, and the minimum data input period of the last bit at reception. At slave, setup for the internal clock is needed to keep data holding time at data transmission. After the last bit data output holding period, "H" is output.

**Table 14-3-4 Last Bit Data Length of Transmission Data**

	at transmission the last bit data holding period	at reception the last bit data input period
at master	1 bit data length	1 bit data length (minimum)
at slave	[1 bit data length of external clock x 1/2] + [internal clock cycle x (1/2 to 1) ]	



Transfer rate should be up to 2.5 MHz. If the transfer rate is over 2.5 MHz, the transmission data cannot be output correctly.

■ Transmission Timing

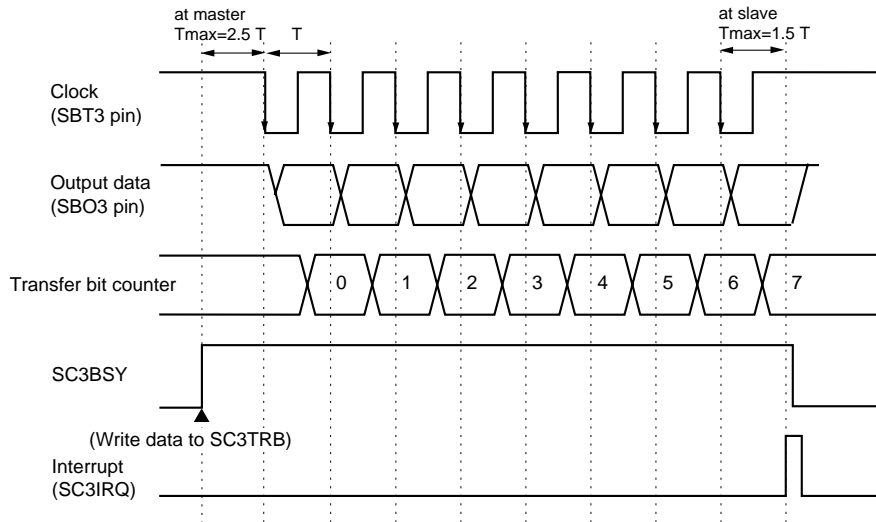


Figure 14-3-2 Transmission Timing (Falling edge, Enable Start Condition)

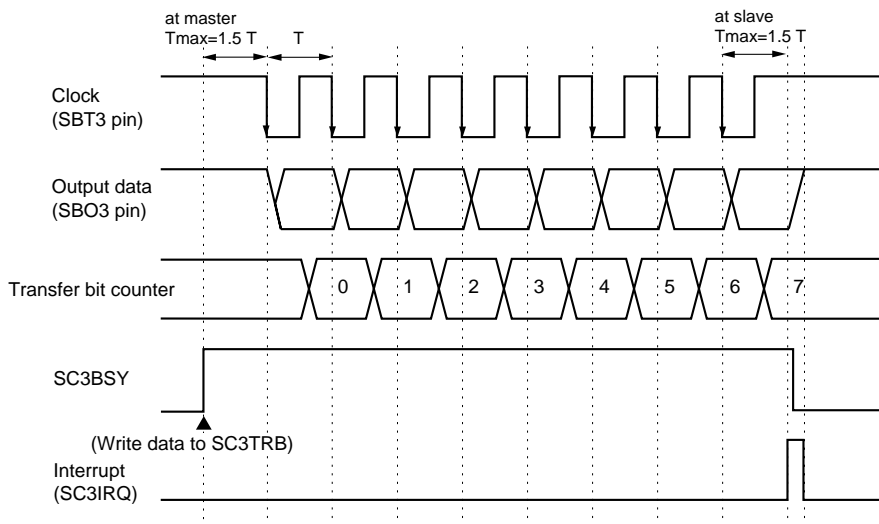
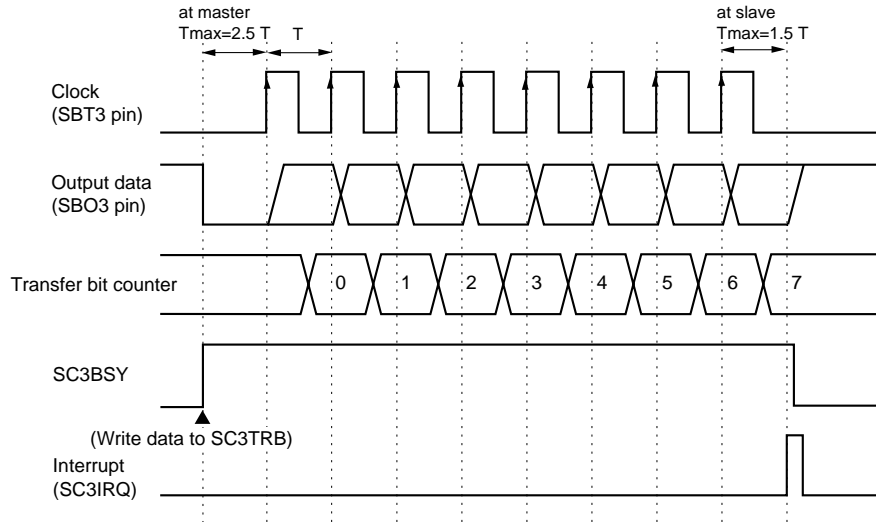
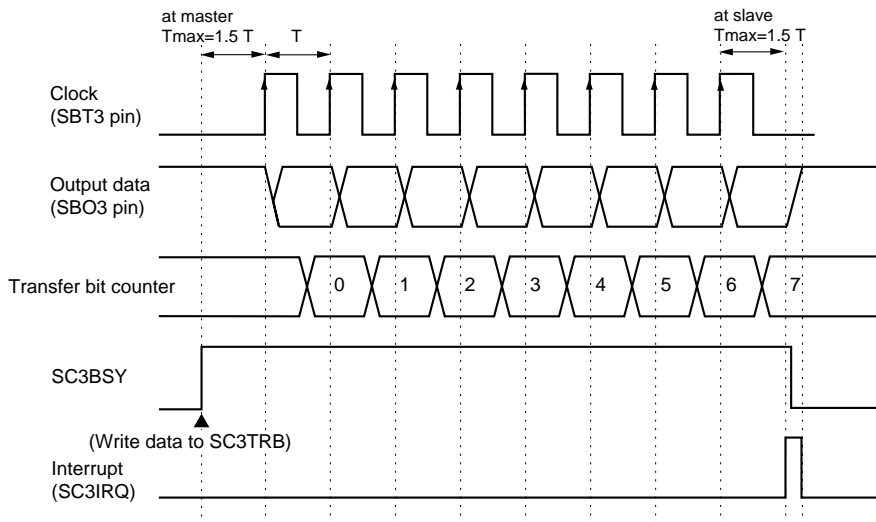


Figure 14-3-3 Transmission Timing (Falling edge, Disable Start Condition)



**Figure 14-3-4 Transmission Timing (Rising edge, Enable Start Condition)**



**Figure 14-3-5 Transmission Timing (Rising edge, Disable Start Condition)**

■ Reception Timing

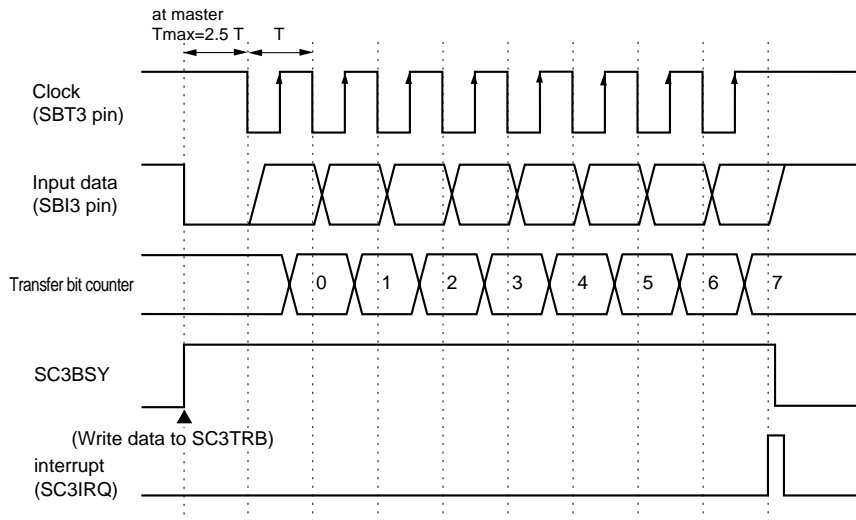


Figure 14-3-6 Reception Timing (Rising edge, Enable Start Condition)

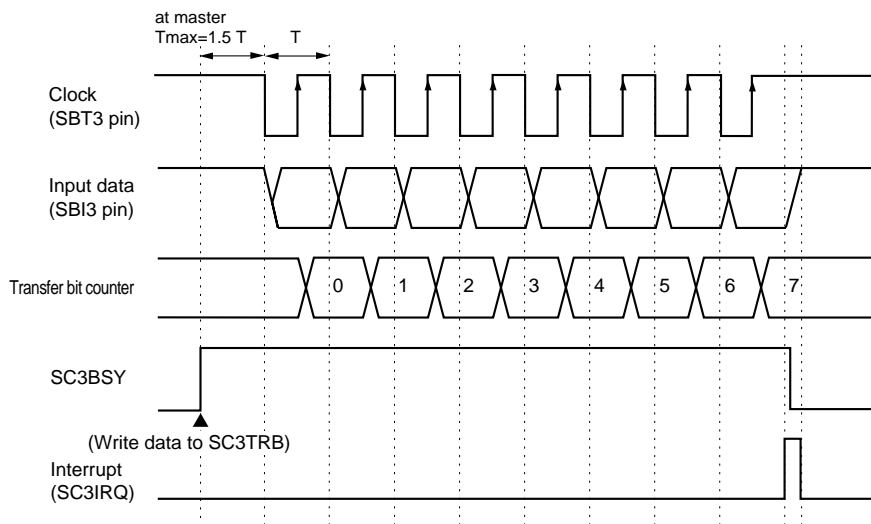
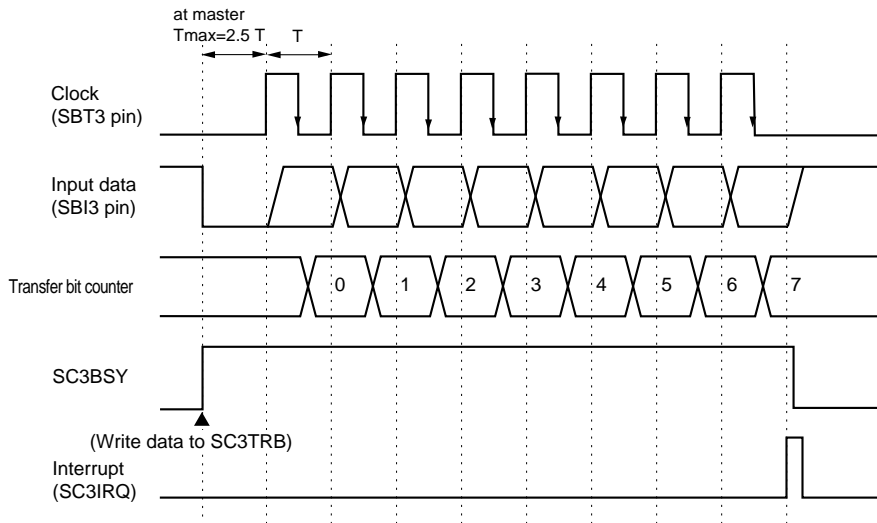
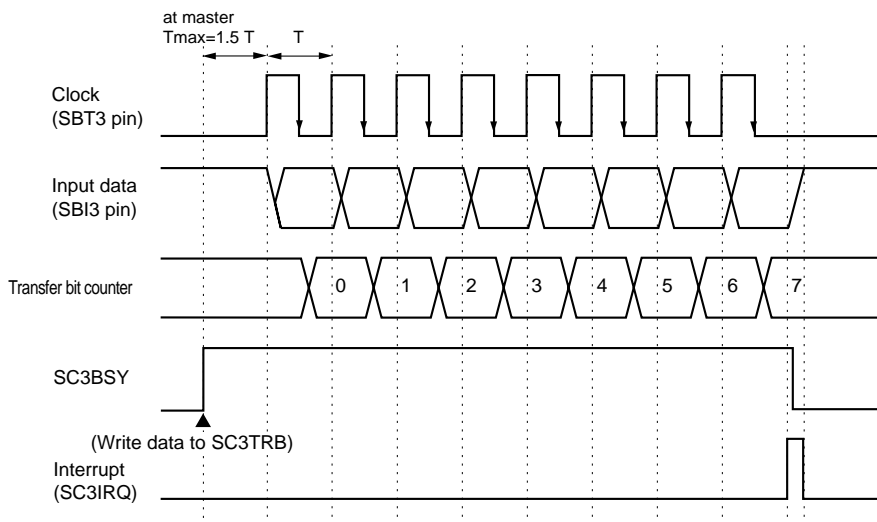


Figure 14-3-7 Reception Timing (Rising edge, Disable Start Condition)





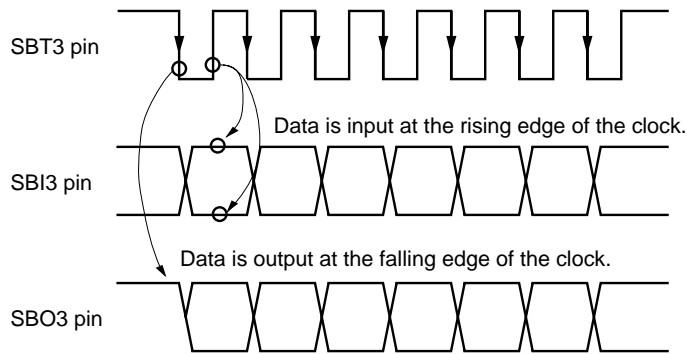
**Figure 14-3-8 Reception Timing (Falling edge, Enable Start Condition)**



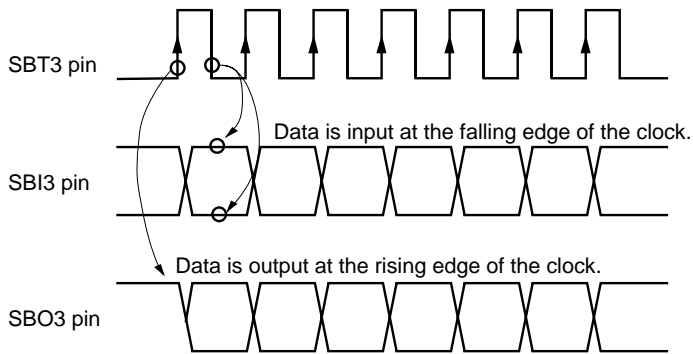
**Figure 14-3-9 Reception Timing (Falling edge, Disable Start Condition)**

■Transmission/Reception Simultaneous timing

When transmission and reception are operated at the same time, data is received at the opposite edge of the transmission clock.



**Figure 14-3-10 Transmission/Reception Timing  
(Reception : Rising edge, Transmission : Falling edge)**



**Figure 14-3-11 Transmission/Reception Timing  
(Reception : Falling edge, Transmission : Rising edge)**

■ Pin Setup (3 channels, at transmission)

Table 14-3-5 shows the pins setup at synchronous serial interface transmission with 3 channels (SBO3 pin, SBI3 pin, SBT3 pin).

**Table 14-3-5 Synchronous Serial Interface Pin Setup (3 channels, at transmission)**

Item	Data output pin	Data input pin	Clock I/O pin	
	SBO3 pin	SBI3 pin	SBT3 pin	
			internal clock	external clock
Pin	P33	P34	P35	
SBI3/SBO3 pin	SBI3/SBO3 independent		-	
	SC3MD1(SC3IOM)			
Function	serial data output	input "1"	serial clock I/O	serial clock I/O
	SC3MD1(SC3SBOS)	SC3MD1(SC3SBIS)	SC3MD1(SC3SBTS)	
Type	Push-pull/ N-ch open-drain	-	push-pull/ N-ch open-drain	push-pull/ N-ch open-drain
	SC3ODC(SC3ODC0)		SC3ODC(SC3ODC1)	
I/O	output mode	-	output mode	input mode
	P3DIR(P3DIR3)		P3DIR(P3DIR5)	
Pull-up	added/not added	-	added/not added	added/not added
	P3PLU(P3PLU3)		P3PLU(P3PLU5)	

■Pin Setup (3 channels, at reception)

Table 14-3-6 shows the pins setup at synchronous serial interface reception with 3 channels (SBO3 pin, SBI3 pin, SBT3 pin).

**Table 14-3-6 Synchronous Serial Interface Pin Setup (3 channels, at reception)**

Item	Data output pin	Data input pin	Clock I/O pin	
	SBO3 pin	SBI3 pin	SBT3 pin	
			internal clock	external clock
Pin	P33	P34	P35	
SBI3/SBO3 pin	SBI3/SBO3 independent		-	
	SC3MD1(SC3IOM)			
Function	Port	Serial data input	Serial clock I/O	Serial clock I/O
	SC3MD1(SC3SBOS)	SC3MD1(SC3SBIS)	SC3MD1(SC3SBTS)	
Type	-	-	Push-pull / N-ch open-drain	Push-pull / N-ch open-drain
			SC3ODC(SC3ODC1)	
I/O	-	Input mode	Output mode	Input mode
		P3DIR(P3DIR4)	P3DIR(P3DIR5)	
Pull-up	-	-	added/not added	added/not added
			P3PLU(P3PLU5)	

■ Pin Setup (3 channels, at transmission/reception)

Table 14-3-7 shows the pins setup at synchronous serial interface transmission/reception with 3 channels (SBO3 pin, SBI3 pin, SBT3 pin).

**Table 14-3-7 Synchronous Serial Interface Pin Setup  
(3 channels, at transmission/reception)**

Item	Data output pin	Data input pin	Clock I/O pin	
	SBO3 pin	SBI3 pin	SBT3 pin	
			internal clock	external clock
Pin	P33	P34	P35	
SBI3/SBO3 pin	SBI3/SBO3 independent		-	
	SC3MD1(SC3IOM)			
Function	Serial data output	Serial data input	Serial clock I/O	Serial clock I/O
	SC3MD1(SC3SBOS)	SC3MD1(SC3SBIS)	SC3MD1(SC3SBTS)	
Type	Push-pull/ N-ch open-drain	-	Push-pull/ N-ch open-drain	Push-pull/ N-ch open-drain
	SC3ODC(SC3ODC0)		SC3ODC(SC3ODC1)	
I/O	Output mode	Input mode	output mode	input mode
	P3DIR(P3DIR3)	P3DIR(P3DIR4)	P3DIR(P3DIR5)	
Pull-up	added/not added	-	added/not added	added/not added
	P3PLU(P3PLU3)		P3PLU(P3PLU5)	

■Pin Setup (2 channels, at transmission)

Table 14-3-8 shows the pins setup at synchronous serial interface transmission with 2 channels (SBO3 pin, SBT3 pin). The SBI3 pin is not used, so that it can be used as a general port.

**Table 14-3-8 Synchronous Serial Interface Pin Setup (2 channels, at transmission)**

Item	Data I/O pin	Serial unused pin	Clock I/O	
	SBO3 pin	SBI3 pin	SBT3 pin	
			internal clock	external clock
Pin	P33	P34	P35	
SBI3/SBO3 pin	SBI3/SBO3 connection		-	
	SC3MD1(SC3IOM)			
Function	Serial data output	input "1"	Serial clock I/O	Serial clock I/O
	SC3MD1(SC3SBOS)	SC3MD1(SC3SBIS)	SC3MD1(SC3SBTS)	
Type	Push-pull/ N-ch open-drain	-	Push-pull/ N-ch open-drain	Push-pull/ N-ch open-drain
	SC3ODC(SC3ODC0)		SC3ODC(SC3ODC1)	
I/O	output mode	-	output mode	input mode
	P3DIR(P3DIR3)		P3DIR(P3DIR5)	
Pull-up	added/not added	-	added/not added	added/not added
	P3PLU(P3PLU3)		P3PLU(P3PLU5)	

■ Pin Setup (2 channels, at reception)

Table 14-3-9 shows the pins setup at synchronous serial interface reception with 2 channels (SBO3 pin, SBT3 pin). The SBI3 pin is not used, so that it can be used as a general port.

**Table 14-3-9 Synchronous Serial Interface Pin Setup (2 channels, at reception)**

Item	Data I/O pin	Serial unused pin	Clock I/O pin	
	SBO3 pin	SBI3 pin	SBT3 pin	
			internal clock	external clock
Pin	P33	P34	P35	
SBI3/SBO3 pin	SBI3/SBO3 connection		-	
	SC3MD1(SC3IOM)			
Function	Port	Serial data input	serial clock I/O	serial clock I/O
	SC3MD1(SC3SBOS)	SC3MD1(SC3SBIS)	SC3MD1(SC3SBTS)	
Type	-	-	Push-pull/ N-ch open-drain	Push-pull/ N-ch open-drain
			SC3ODC(SC3ODC1)	
I/O	Input mode	-	Output mode	Input mode
	P3DIR(P3DIR3)		P3DIR(P3DIR5)	
Pull-up	-	-	added/not added	added/not added
			P3PLU(P3PLU5)	

## 14-3-2 Setup Example

### ■Transmission/Reception Setup Example

Here is the setup example for transmission/reception with serial interface 3. Table 14-3-10 shows the conditions.


**Table 14-3-10 Setup conditions for Synchronous Serial Interface Transmission/Reception**

Item	set to	Item	set to
SBI3/SBO3 pin	independent (with 3 channels)	Clock	internal clock
Transfer bit count	8 bit	Clock source	fs/2
Start condition	enable	SBT3/SBO3 pin's type	N-ch open-drain
First bit to be transferred	MSB	Pull-up resistance of SBT3 pin	added
Input clock edge	falling edge	Pull-up resistance of SBO3 pin	added
Output clock edge	rising edge		

An example setup procedure, with a description of each step is shown below.


Setup Procedure	Description
(1) Select prescaler operation. PSCMD (x'3F6F') bp0 : PSCEN = 1	(1) Set the PSCEN flag of the PSCMD register to "1" to select prescaler operation.
(2) Select the clock source. SC3CKS (x'3FAF') bp2-0 : SC2PSC2-0 = 100 bp3 = 0	(2) Set the SC3PSC2-0 flag of the SC3CKS register to "100" to select fs/2 at clock source. Set bp3 of the SC3CKS register to "0", always.
(3) Control the pin type. SC3ODC (x'3FAE') bp1-0 : SC3ODC1-0 = 11 POPLU (x'3F43') bp5, 3 : P3PLU5, 3 = 1, 1	(3) Set the SC3ODC1-0 flag of the SC3ODC register to "11" to select N-ch open drain for the SBO3/SBT3 pin's type. Set the P3PLU5, 3 flag of the P3PLU register to "1, 1" to add pull-up resistor.
(4) Control the pin direction. P3DIR (x'3F33') bp5-3 : P3DIR5-3 = 101	(4) Set the P3DIR5-3 flag of P3 pin control direction register (P3DIR) to "101" to set P33, P35, to output mode, to set P34 to input mode.
(5) Select the communication type. SC3CTR (x'3FAA') bp2 : SC3CMD = 0	(5) Set the SC3CMD flag of the serial 3 control register (SC3CTR) to "0" to select synchronous serial.





Setup Procedure	Description
<p>(6) Set the SC3MD0 register. Select the transfer bit count. SC3MD0 (x'3FA8') bp2-0 : SC3LNG2-0 = 111</p> <p>Select the start condition. SC3MD0 (x'3FA8') bp3 : SC3STE = 1</p> <p>Select the first transfer bit. SC3MD0 (x'3FA8') bp4 : SC3DIR = 0</p> <p>Select the transfer edge. SC3MD0 (x'3FA8') bp6 : SC3CE1 = 1</p>	<p>(6) Set the SC3LNG2-0 flag of the serial 3 mode register (SC3MD0) to "111" to set the transfer bit count to 8 bits.</p> <p>Set the SC3STE flag of the SC3MD0 register to "1" to enable start condition.</p> <p>Set the SC3DIR flag of the SC3MD0 register to "0" to set MSB as the first bit to be transferred.</p> <p>Set the SC3CE1 flag of the SC3MD0 register to "1" to set the transmission data output edge to "rising", and the received data input edge to "falling".</p>
<p>(7) Set the SC3MD1 register. Select the transfer clock. SC3MD1 (x'3FA9') bp2 : SC3MST = 1</p> <p>Control the pin function. SC3MD1 (x'3FA9') bp4 : SC3SBOS = 1 bp5 : SC3SBIS = 1 bp6 : SC3SBTS = 1 bp7 : SC3IOM = 0</p>	<p>(7) Set the SC3MST flag of the SC3MD1 register to "1" to select clock master (internal clock).</p> <p>Set the SC3SBOS, SC3SBIS, SC3SBTS flags of the SC3MD1 register to "1" to set the SBO3 pin to serial data output, the SBI3 pin to serial data input, and the SBT3 pin to serial clock I/O. Set the SC3IOM flag to "0" to set "serial data input from the SBI3 pin".</p>
<p>(8) Set the other mode register. SC3CTR (x'3FAA') bp7-6, 3, 1-0</p>	<p>(8) At IIC communication, that flag should be set. At synchronous serial communication, no need to be set.</p>
<p>(9) Set the interrupt level. SC3ICR (x'3FF9') bp7-6 : SC3LV1-0 = 10</p>	<p>(9) Set the interrupt level by the SCLV1-0 flag of the serial 3 interrupt control register (SC3ICR).</p>
<p>(10) Enable the interrupt. SC3ICR (x'3FF9') bp1 : SC3IE = 1</p>	<p>(10) Enable the interrupt to the SC3IE flag of the SC3ICR register. If the interrupt request flag (SC3IR of the SC3ICR register) is already set, clear SC3IR before the interrupt is enabled.</p> <p>[  Chapter 3 3-1-4. Interrupt Flag Setup ]</p>


Setup Procedure	Description
(11) Start serial transmission. Transmission data → SC3TRB (x'7'3FAB')	(11) Set the transmission data to the serial transmit/receive shift register SC3TRB. The internal clock is generated to start transmission/reception.  After the communication is finished, the serial 3 interrupt SC3IRQ is generated.


Note : In the above (6) and (7), each settings can be set at once.


 If the communication is only for transmission, the data that input by setting the SC3SBIS of the SC3MD1 register to "0" should be fixed to "1". The SBI3 pin can be used as a general port.


 If the communication is only for reception, set the SC3SBOS of the SC3MD1 register to "0" to select port. The SBO3 pin can be used as a general port.

 If the communication is with 2 channels connected the SBO3/SBI3 pins, the SBO3 pin inputs/outputs serial data. The port direction control register P3DIR switches I/O.  
 At reception, set the SC3SBIS of the SC3MD1 register to "1" to select "input serial data". The SBI3 pin can be used as a general port.

 It is possible to shut down the communication. When the communication should be stopped by force, set the SC3SBOS and the SC3SBIS of the SC3MD1 register to "0".

 Setup for each flag should be done in order. The activation of communication should be operated after all control registers (table 14-2-1 : except SC3TRB) are set.

 The SC3CKS register should set the transfer rate of the transfer clock to "under 2.5 MHz".

 When timer output is selected as serial interface transfer clock, select fosc as a clock source of the timer. If other clock is selected, normal transfer of serial interface data is not guaranteed.

### 14-3-3 Single Master IIC Interface

IIC serial communication in single master is available at serial interface 3. Communication of this IIC interface is based on the data transfer format of Philips, IIC-BUS.

Table 14-3-11 shows the functions of IIC serial interface.

**Table 14-3-11 IIC Serial Interface Functions**

Communication type	Single master IIC
Interrupt	SC3IRQ
Pins	SDA, SCL
Transfer bit count	1 to 8 bit
First transfer bit	√
ACK bit	√
ACK bit level	√
Clock source	fosc/2 fosc/4 fosc/16 fosc/32 fs/2 fs/4 timer 3 output
The transfer rate is the clock source divided by 3.	

■Activation factor for Communication

Set data (at transmission) or dummy data (at reception) to the transmit/receive shift register SC3TRB. Start condition and transfer clock are generated to start communication, regardless of transmission/reception. This serial interface can not be used for slave communication.

■Start Condition Setup

At IIC communication, enable start condition by the SC3STE flag of the SC3MD0 register at the beginning of communication. The SC3STE flag of the SC3MD0 register can select if start condition is enabled or not.

If start condition is detected during data communication when the start condition is enabled, the SC3STC flag of the SC3CTR register is set to "1", and the communication complete interrupt SC3IRQ is generated to finish the transmission. At this case, the communication is not normal so that something should be done by the software, such a counter measure of stop condition, and the communication should be started again.

The SC3STC flag should be cleared by the software.

Start condition is generated as data line (SDA pin) is changed from "H" to "L", when clock line (the SCL pin) is "H".

■Generation of Stop Condition

Stop condition is generated as the SDA line is changed from "L" to "H", when the SCL line is "H". Stop condition can be generated by setting the IICBSY flag of the SC3CTR register to "0" by the software. When the IICBSY flag is "0", use the program with data output function of a general port.

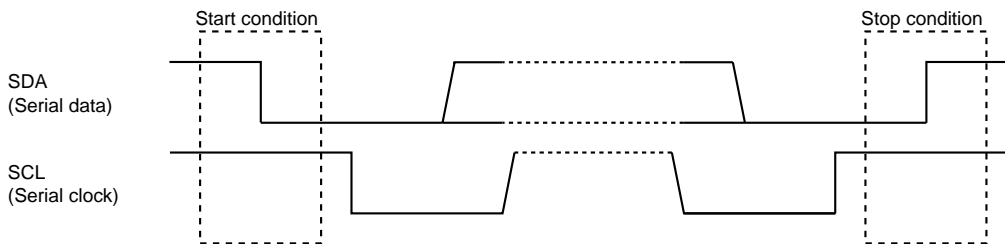



Figure 14-3-12 Start Condition and Stop Condition


■Input Edge/Output Edge Setup

At IIC communication, data is always received at the falling edge of clock. Set the SC3CE1 flag of the SC3MD0 register to "1", and select "falling" at the received data input edge. Even if the SC3CE1 flag is set to "0", the received data is stored at the falling edge of clock, but any error is generated because IIC clock line (SCL) becomes "H" after the communication of the last data.

 At IIC communication, set the SC3CE1 flag of the SC3MD0 register to "1" to select "falling" of the received data input edge.

■Data I/O Pin Setup

The SDA pin (for SBO3 pin, too) is used to input/output data. Set the SC3IOM flag of the SC3MD1 register to "1" to input serial data from the SBO3 pin. The SBI3 pin is not used, so it can be used as a general port. But, always set the SC3SBIS flag of the above register to "1" to set "input serial data".

 To detect start condition, set the SC3SBIS flag of the SC3MD1 register to "input serial data", regardless of transmission/reception.

### ■ Reception of Confirming (ACK) Bit after Data Transmission

The SC3ACKS flag of the SC3CTR register selects if ACK bit is enabled or not. If ACK bit is enabled, ACK bit is received from the slave station after data (1 to 8 bits) is transferred. At reception of ACK bit, the SDA line is automatically released. To receive ACK bit, 1 clock is output to store ACK bit to the SC3ACK0 of the SC3CTR register. The transmit/receive shift register SC3TRB is not operated by the ACK bit reception clock. When the received ACK bit level is "L", the reception is normal at slave and the next data can be received. If the level is "H", the reception maybe completed at slave, so that set the IICBSY flag of the SC3CTR register to "0" to finish communication.

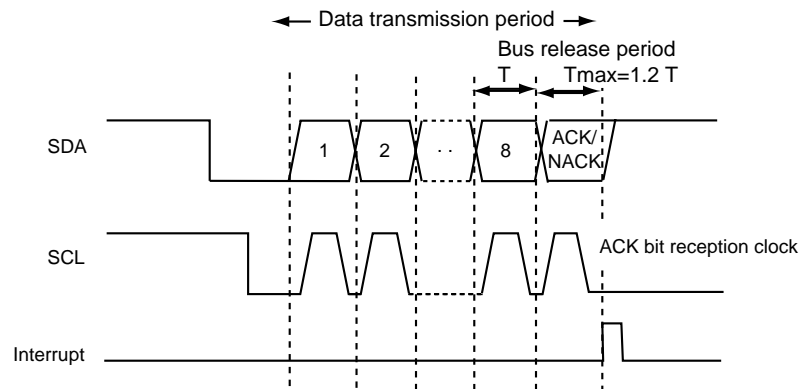


Figure 14-3-13 ACK Bit Reception Timing after Transmission of 8-bit Data

### ■ Transmission of Confirming (ACK Bit) after Data Reception

The way of the selection if ACK bit is enabled or not is the same to the way at the transmission. When ACK bit is enabled, ACK bit and clock are output after data (1 to 8 bits) is received. If the reception is to continue, ACK bit outputs "L". And if the reception is to finish, it outputs "H". The SC3ACK0 of the SC3CTR register sets the output ACK bit level.

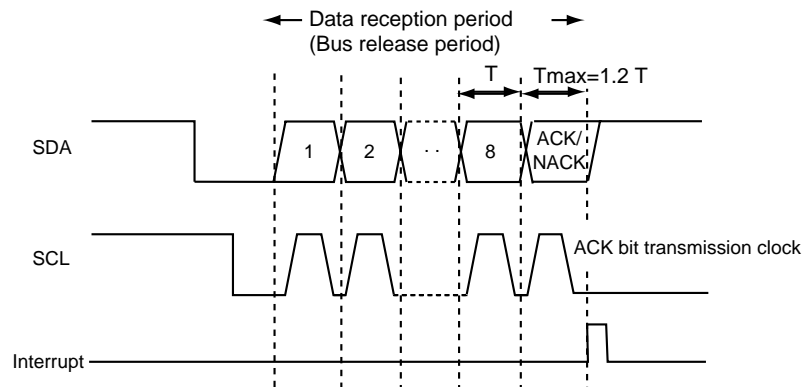
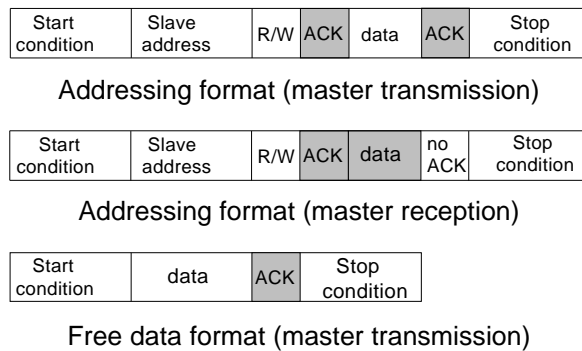


Figure 14-3-14 ACK Bit Transmission Timing after Reception of 8-bit Data

■Transfer Format

On IIC bus, there are 2 transfer formats : the addressing format that transmits/receives data after 1 byte data (address data) that consists of slave address (7 bits) and R/W bit (1 bit) is transferred after start condition, and the free data format that transmits data after start condition. The serial interface of this LSI supports 2 communication formats for only master transmission and master reception at IIC communication. Sequence of communication is as follows. The shaded part is shown the data, transferred from slave.

[  Figure 14-3-16 Master Transmission Timing, Figure 14-3-17 Master Reception Timing ]




**Figure 14-3-15 Communication Sequence on Each Transfer Format**

■Clock Setup

The transfer clock of IIC communication is the one that the clock source is divided by 3 inside of this serial. The clock source is selected from the dedicated prescaler and timer 3 output by the SC3CKS register. But clock source should be set so that the transfer rate is not over 400 kHz. The dedicated prescaler starts as the PSCMD (x'03F6F') register selects "prescaler operation". Set the SC3MST flag of the SC3MD1 register to "1" to select the internal clock (clock master), always. This IIC interface can not used as the external clock (clock slave).

**Table 14-3-12 IIC Interface Clock Source**

Communication type	Single master IIC
Clock source (internal clock)	fosc/2
	fosc/4
	fosc/16
	fosc/32
	fs/2
	fs/4
	timer 3 output


 The transfer rate at IIC communication should be the one that clock source is divided by 3. The clock source should be set so that the transfer rate is under 400 kHz by the SC3CKS register.

#### ■Transmission/Reception Mode Setup and Operation

The SC3REX flag of the SC3CTR register selects the status of the transmission or the reception. The first data is always added start condition for communication. The start condition is output from the master, this serial.

If the communication is continued (no stop condition is generated), start condition should not be added from the next data. At this case, start condition is set to be disabled in the interrupt service routine after the first data communication is finished. At addressing format, slave address and R/W bit are set to the first data after start condition for transmission.

At master reception, switch to the reception mode at the interrupt transaction after the transmission of the first 1 byte data is finished, after the ACK signal from slave is confirmed. If the communication should be continued to other device without stop, transmit slave address and R/W bit again after start condition is generated again. At reception, the SDA line is automatically released to wait for reception. After the storage of data is finished, confirmation of the reception (ACK bit) is output.

[  Figure 14-3-16 Master Transmission Timing, Figure 14-3-17 Master Reception Timing ]

#### ■IICBUSY Flag Operation

As data is set to the transmit/receive shift register SC3TRB, the IICBSY flag of the SC3CTR register is set to "1". The IICBSY flag is cleared by software. As the IICBSY flag is cleared, the stop condition is automatically generated to complete the communication.

If start condition is detected during communication, the communication complete interrupt SC3IRQ is generated, then the IICBSY flag is automatically cleared.

#### ■Seaquence Communication

At IIC communication, not the same to the clock synchronous serial communication, the seaquence communication with built-in automatic transfer controller ATC1, is not available.

The following items are the same to the clock synchronous serial. Refer to the following pages.

#### ■First Transfer Bit Setup

Refer to : XIV-11

#### ■Transmit, Reception Data Buffer

Refer to : XIV-11

#### ■Transfer Bit Count and First Transfer Bit

Refer to : XIV-11

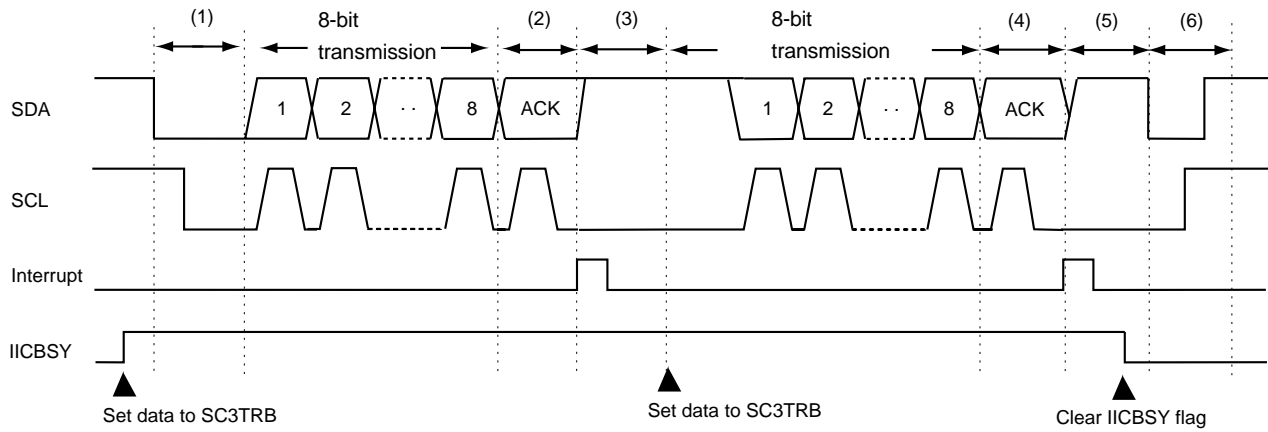
#### ■Communication Forced Reset

Refer to : XIV-13



At communication, set Nch-open drain for pin's type, because the hardware switches if bus is used/released. And even at reception, select the SDA pin (the SBO3 pin) direction control to "output".

■ Master Transmission Timing

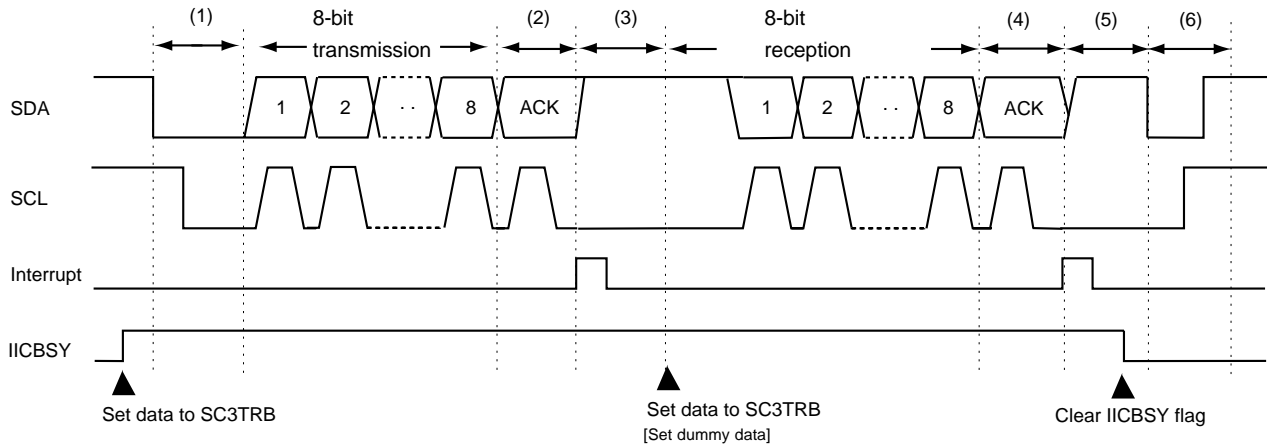


- (1) Output start condition.
- (2) Bus released period, ACK bit is received.
- (3) Interrupt transaction.
  - Disable start condition :  $SC3STE = 1 \rightarrow 0$
  - Start communication : set data to SC3TRB
- (4) Receive ACK bit.
- (5) Interrupt transaction.
  - Finish communication : clear the IICBSY flag.
- (6) Generates stop condition.

**Figure 14-3-16 Master Transmission Timing**



### ■ Master Reception Timing



- (1) Output start condition.
- (2) Bus released period, ACK bit is received.
- (3) Interrupt transaction
  - Setup for the reception mode :  $SC3REX = 0 \rightarrow 1$
  - Disable start condition :  $SC3STE = 1 \rightarrow 0$
  - Start communication : set data to SC3TRB.
- (4) Output ACK bit.
- (5) Bus released period, interrupt transaction
  - Complete communication : clear IICBSY flag
- (6) Generate stop condition.

**Figure 14-3-17 Master Reception Timing**

■Pin Setup (2 channels, at transmission)

Table 14-3-13 shows the pins setup at IIC serial interface transmission with 2 channels (SDA pin, SCL pin).

**Table 14-3-13 Pin Setup (2 channels, at transmission)**

Item	Data I/O pin	Clock output pin
	SDA pin	SCL pin
Pin	P33	P35
SBI3/SBO3 pins	SBI3/SBO3 pin connection	-
	SC3MD1(SC3IOM)	
Function	Serial data output	Serial clock output
	SC3MD1(SC3SBOS)	SC3MD1(SC3SBTS)
	Serial data input	-
	SC3MD1(SC3SBIS)	
Type	Push-pull/ N-ch open-drain	Push-pull/ N-ch open-drain
	SC3ODC(SC3ODC0)	SC3ODC(SC3ODC1)
I/O	output mode	output mode
	P3DIR(P3DIR3)	P3DIR(P3DIR5)
Pull-up	added / not added	added / not added
	P3PLU(P3PLU3)	P3PLU(P3PLU5)

■ Pin Setup (2 channels, at reception)

Table 14-3-14 shows the pins setup at IIC serial interface reception with 2 channels (SDA pin, SCL pin).

**Table 14-3-14 Pin Setup (2 channels, at reception)**

Item	Data I/O pin	Clock output pin
	SDA pin	SCL pin
Pin	P33	P35
SBI3/SBO3 pins	SBI3/SBO3 pin connection	-
	SC3MD1(SC3IOM)	
Function	Port	Serial clock output
	SC3MD1(SC3SBOS)	SC3MD1(SC3SBTS)
	Serial data input	-
	SC3MD1(SC3SBIS)	
Type	Push-pull/ N-ch open-drain	Push-pull/ N-ch open-drain
	SC3ODC(SC3ODC0)	SC3ODC(SC3ODC1)
I/O	Input mode	Output mode
	P3DIR(P3DIR3)	P3DIR(P3DIR5)
Pull-up	added / not added	added / not added
	P3PLU(P3PLU3)	P3PLU(P3PLU5)

## 14-3-4 Setup Example

### ■ Master Transmission Setup Example

Here is the setup example for the transmission of the plural data to the all devices on IIC bus with IIC interface function of serial 3. Figure 14-3-15 shows the conditions.


**Figure 14-3-15 Conditions Single Master IIC Communication Setup**

Item	Set to	Item	Set to
SBI3/SBO3 pins	Connection (with 2 lines)	Clock source	fs/2
Transfer bit count	8 bits	SCL/SDA pin's type	N-ch open- drain
Start condition	enable	Pull-up resistance of SCL pin	added
First transfer bit	MSB	Pull-up resistance of SDA pin	added
ACK bit	enable		

An example setup procedure, with a description of each step is shown below.

Setup Procedure	Description
(1) Select prescaler operation. PSCMD (x'3F6F') bp0 : PSCEN = 1	(1) Set the PSCEN flag of the PSCMD register to "1" to select prescaler operation.
(2) Select the clock source. SC3CKS (x'3FAF') bp2-0 : SC2PSC2-0 = 100 bp3 = 0	(2) Set the SC3PSC2-0 flag of the SC3CKS register to "100" to select fs/2 at clock source. Set bp3 of the SC3CKS register to "0", always.
(3) Control the pin type. SC3ODC (x'3FAE') bp1-0 : SC3ODC1-0 = 11 P3PLU (x'3F43') bp5, 3 : P3PLU5, 3 = 1, 1	(3) Set the SC3ODC1, 0 flag of the SC3ODC register to "11" to select N-ch open drain for the SDA/SCL pin type. Set the P3PLU5, 3 flag of the P3PLU register to "1, 1" to add pull-up resistor.
(4) Control the pin direction. P3DIR (x'3F33') bp5, 3 : P3DIR5, 3 = 1, 1	(4) Set the P3DIR5, 3 flag of P3 pin control direction register (P3DIR) to "1, 1" to set P33, P35, to output mode.

Setup Procedure	Description
(5) Set ACK bit. SC3CTR (x'3FAA') bp0 : SC3ACK0 = x bp1 : SC3ACKS = 1	(5) Set the SC3ACKS flag of the serial 3 control register (SC3CTR) to "1" to select "receive ACK bit". At transmission, ACK bit is received, so that the SC3ACKS flag does not need to set the ACK bit level.
(6) Select the communication type. SC3CTR (x'3FAA') bp2 : SC3CMD = 1	(6) Set the SC3CMD flag of the serial 3 control register (SC3CTR) to "1" to select IIC.
<Transmission setup>	
(7) Select the transmission/reception mode. SC3CTR (x'3FAA') bp3 : SC3REX = 0	(7) Set the SC3REX flag of the serial 3 control register (SC3CTR) to "0" to select the transmission mode.
(8) Initialize the monitor flag. SC3CTR (x'3FAA') bp6 : SC3STC = 0 bp7 : IICBSY = 0	(8) Set the SC3STC flag and the IICBSY flag of the serial 3 control register (SC3CTR) to "0, 0" to initialize the start condition detection flag and the BUSY flag.
(9) Set the SC3MD0 register. Select the transfer bit count. SC3MD0 (x'3FA8') bp2-0 : SC3LNG2-0 = 111	(9) Set the SC3LNG2-0 flag of the serial 3 mode register (SC3MD0) to "111" to set the transfer bit count to 9 bits.
Select the start condition. SC3MD0 (x'3FA8') bp3 : SC3STE = 1	Set the SC3STE flag of the SC3MD0 register to "1" to enable start condition.
Select the first bit to be transferred. SC3MD0 (x'3FA8') bp4 : SC3DIR = 0	Set the SC3DIR flag of the SC3MD0 register to "0" to set MSB as the first bit to be transferred.
Select the IIC communication edge. SC3MD0 (x'3FA8') bp6 : SC3CE1 = 1	At IIC communication, set the SC3CE1 flag of the SC3MD0 register to "1", always.

Setup Procedure	Description
<p>(10) Set the SC3MD1 register.            Select the transfer clock.            SC3MD1 (x'3FA9')            bp2 : SC3MST = 1</p> <p>Control the pin function.            SC3MD1 (x'3FA9')            bp4 : SC3SBOS = 1            bp5 : SC3SBIS = 1            bp6 : SC3SBTS = 1            bp7 : SC3IOM = 1</p> <p>(11) Set the interrupt level.            SC3ICR (x'3FF9')            bp7-6 : SC3LV1-0 = 10</p> <p>(12) Enable the interrupt.            SC3ICR (x'3FF8')            bp1 : SC3IE = 1</p> <p>&lt;Transmission is started.&gt;</p> <p>(13) Start serial transmission.            Confirm that SCL (P33) is "H".            Transmission data                → SC3TRB (x'3FAB')</p> <p>&lt;Transmission is completed.&gt;</p> <p>&lt;Setup for the next data transmission&gt;</p> <p>(14) Judge the monitor flag.            SC3CTR (x'3FAA')            bp6 : SC3STC</p>	<p>(10)            Set the SC3MST flag of the SC3MD1 register to "1" to select clock master (internal clock).            At IIC communication, external clock should not be selected.</p> <p>Set the SC3SBOS, SC3SBIS, SC3SBTS flags of the SC3MD1 register to "1" to set the SDA pin (the SBO3 pin) to serial data output, the SBI3 pin to serial data input, and the SCL pin (the SBT3 pin) to serial clock I/O. Set the SC3IOM flag to "1" to set "serial data input from the SDA pin (the SBO3 pin)".</p> <p>(11) Set the interrupt level by the SCLV1-0 flag of the serial 3 interrupt control register (SC3ICR).</p> <p>(12) Enable the interrupt to the SC3IE flag of the SC3ICR register. If the interrupt request flag (SC3IR of the SC3ICR register) is already set, clear SC3IR before the interrupt is enabled.</p> <p>[  Chapter 3 3-1-4. Interrupt Flag Setup ]</p> <p>(13) Set the transmission data to the transmit/receive shift register SC3TRB. Then the transfer clock is generated to start transmission. If the ACK bit is received after data transmission, the communication complete interrupt SC3IRQ is generated.</p> <p>(14) Confirm the SC3STC flag of the serial 3 control register (SC3CTR). When the former transmission is completed in normal, SC3STC = "0". If SC3STC = "1", the communication should be operated again.</p>

Setup Procedure	Description
<p>(15) Judge the ACK bit level.  SC3CTR (x'3FAA')  bp0 : SC3ACK0</p> <p>(16) Set the SC3MD0 register.  Select the transfer bit count.  SC3MD0 (x'3FA8')  bp2-0 : SC3LNG2-0 = 0</p> <p>Select the start condition.  SC3MD0 (x'3FA8')  bp3 : SC3STE = 0</p> <p>&lt;The next data transmission is started.&gt;  (17) Serial transmission is started. [ → (13)]</p> <p>&lt;The transmission is finished.&gt;</p> <p>&lt;Transaction after IIC communication&gt;  (18) Clear BUSY flag.  SC3CTR (x'3FAA')  bp7 : IICBSY = 0</p>	<p>(15) Confirm the level of the ACK bit, received by the SC3ACKS flag of the serial 3 control register (SC3CTR). When SC3ACKO = 0, the transmission is continued. When SC3ACKO = 1, the reception at slave may be impossible, finish the communication.</p> <p>(16)  If the transfer bit count is changed, set the transfer count bit by the SC3LNG2-0 flag of the serial 3 mode register (SC3MD0).</p> <p>Set the SC3STE flag of the SC3MD0 register to "0" to disable start condition.</p> <p>(17) Set the transmission data to SC3TRB to start the transmission. [ → (13)]</p> <p>(18) Clear the IICBSY flag of the serial 3 control register (SC3CTR) to "0". Then, the stop condition is automatically generated to finish the communication.</p>

Note : In the above (9), (10) and (16), each settings can be set at once.



It is possible to shut down the communication. When the communication should be stopped by force, set the SC3SBOS and the SC3SBIS of the SC3MD1 register to "0".



Setup for each flag should be done in order. The activation of communication should be done after all control registers (except table 14-2-1 : SC3TRB) are set.



The SC3CKS register should set the transfer clock so that the transfer rate is "under 400 kHz".



To detect start condition, connect the SBO3/SBI3 pins to be 2 channels. The SDA pin inputs/outputs serial data.



At communication, select Nch-open drain for the pin type, because the bus should be switched to be used/released by the hardware. And even at the reception, select the SDA pin (the SBO3 pin) direction control to "output".



When timer output is selected as serial interface transfer clock, select fosc as a clock source of the timer. If other clock is selected, normal transfer of serial interface data is not guaranteed.





## 15-1 Overview

### 15-1-1 ATC1

This LSI contains an automatic transfer controller (ATC) that uses direct memory access (DMA) to transfer the contents of the whole memory space (256 KB) using the hardware. This ATC block is called ATC1.

ATC1 is activated by an interrupt or a flag set by the software. Once this occurs, even if it is in the middle of executing an instruction, the microcontroller waits for a time when it can release the bus, stops normal operation, and transfers bus control to ATC1. ATC1 then uses the released bus for the hardware data transfer.

The software sets the activation factor in ATC1 control register 1 (AT1CNT1), then data transfer begins when the AT1ACT flag in ATC1 control register 0 (AT1CNT0) is set to "1". AT1ACT flag is automatically cleared to "0" when ATC1 is activated.


The transfer data counter (AT1TRC) determines the number of transfers that ATC1 makes, up to a maximum of 255 times. There are also 16 transfer modes, set in ATC1 control register 0 (AT1CNT0).



The interrupt enable flag (xxxIE) for interrupt as a trigger factor needs not to be set. This is because the automatic data transfer occurs in the hardware without going through an interrupt service routine. If the interrupt enable flag (xxxIE) is set for the type of interrupt ATC1, a regular interrupt is generated after the automatic transfer ends.



In the memory expansion mode, the automatic data transfer control function (ATC1) can not be used in the space of x'20000' to x'3FFFF'. Use the bank function of CPU for access to the memory space. In the single chip mode and the processor mode, the automatic data transfer control function (ATC1) is valid in the whole memory space. In the memory expansion mode, the all function of ATC1 is supported in the space of x'00000' to x'1FFFF'.

[ Chapter 2 2-6. Bank functions]

## 15-1-2 Functions

Table 15-1-1 and 15-1-2 provide a list of the ATC1 trigger factors and transfer modes.

### ■ATC1 Trigger Factors

**Table 15-1-1 ATC1 Trigger Factors**

Trigger Factors	External interrupt 0
	External interrupt 1
	External interrupt 2
	External interrupt 3
	Timer 0 interrupt
	Timer 1 interrupt
	Timer 7 interrupt
	Timer 7 capture trigger
	Serial interface 0 interrupt
	Serial interface1 interrupt
	Serial interface 2 interrupt
	Serial interface 3 interrupt
	A/D converter interrupt
	Software activation

### ■ATC Transfer Modes

**Table 15-1-2 Transfer Modes**

Transfer Mode	Transfer Direction (*)			Pointer Increment Control		Transfer Operation
	Cycle	Source Address	→ Destination Address	AT1MAP0	AT1MAP1	
Transfer mode 0		AT1MAP0	→ AT1MAP1 (I/O area)	-	-	1-byte data transfer
Transfer mode 1		AT1MAP1 (I/O area)	→ AT1MAP0	-	-	1-byte data transfer
Transfer mode 2		AT1MAP0	→ AT1MAP1 (I/O area)	AT1MAP0+1	-	1-byte data transfer
Transfer mode 3		AT1MAP1 (I/O area)	→ AT1MAP0	AT1MAP0+1	-	1-byte data transfer
Transfer mode 4	1st	AT1MAP0	→ AT1MAP1 (I/O area : even ADR)	AT1MAP0+1	-	1-word data transfer (An even address must be set in AT1MAP1)
	2nd	AT1MAP0 [=AT1MAP0+1]	→ AT1MAP1 (I/O area : odd ADR)	AT1MAP0+1	-	
Transfer mode 5	1st	AT1MAP1 (I/O area : even ADR)	→ AT1MAP0	AT1MAP0+1	-	1 word data transfer (An even address must be set in AT1MAP1)
	2nd	AT1MAP1 (I/O area : odd ADR)	→ AT1MAP0 [=AT1MAP0+1]	AT1MAP0+1	-	
Transfer mode 6	1st	AT1MAP1 (I/O area)	→ AT1MAP0	AT1MAP0+1	-	Two 1-byte data transfers
	2nd	AT1MAP0 [=AT1MAP0+1]	→ AT1MAP1 (I/O area)	AT1MAP0+1	-	
Transfer mode 7	1st	AT1MAP1 (I/O area)	→ AT1MAP0	AT1MAP0+1	-	Two 1-byte data transfers
	2nd	AT1MAP0 [=AT1MAP0+1]	→ AT1MAP1 (I/O area)	-	-	
Transfer mode 8	1st	AT1MAP1 (I/O area : even ADR)	→ AT1MAP0	AT1MAP0+1	-	Two 1-byte data transfers (An even address must be set in AT1MAP1)
	2nd	AT1MAP0 [=AT1MAP0+1]	→ AT1MAP1 (I/O area : odd ADR)	AT1MAP0+1	-	
Transfer mode 9	1st	AT1MAP1 (I/O area : even ADR)	→ AT1MAP0	AT1MAP0+1	-	Two 1-byte data transfers (An even address must be set in AT1MAP1)
	2nd	AT1MAP0 [=AT1MAP0+1]	→ AT1MAP1 (I/O area : odd ADR)	-	-	
Transfer mode A		AT1MAP0	→ AT1MAP1	-	-	1-byte data transfer (whole memory area)
Transfer mode B		AT1MAP1	→ AT1MAP0	-	-	1-byte data transfer (whole memory area)
Transfer mode C		AT1MAP0	→ AT1MAP1	AT1MAP0+1	AT1MAP1+1	1-word data transfer (whole memory area)
Transfer mode D		AT1MAP1	→ AT1MAP0	AT1MAP0+1	AT1MAP1+1	1-word data transfer (whole memory area)
Transfer mode E		AT1MAP0	→ AT1MAP1	AT1MAP0+1	AT1MAP1+1	Burst transfer ( continues until AT1TCR=0)
Transfer mode F		AT1MAP1	→ AT1MAP0	AT1MAP0+1	AT1MAP1+1	Burst transfer ( continues until AT1TCR=0)

(\*) When a memory pointer points to the I/O space, only the lower 8 bits of the pointer are valid.

### 15-1-3 Block Diagram

■ ATC1 Block Diagram

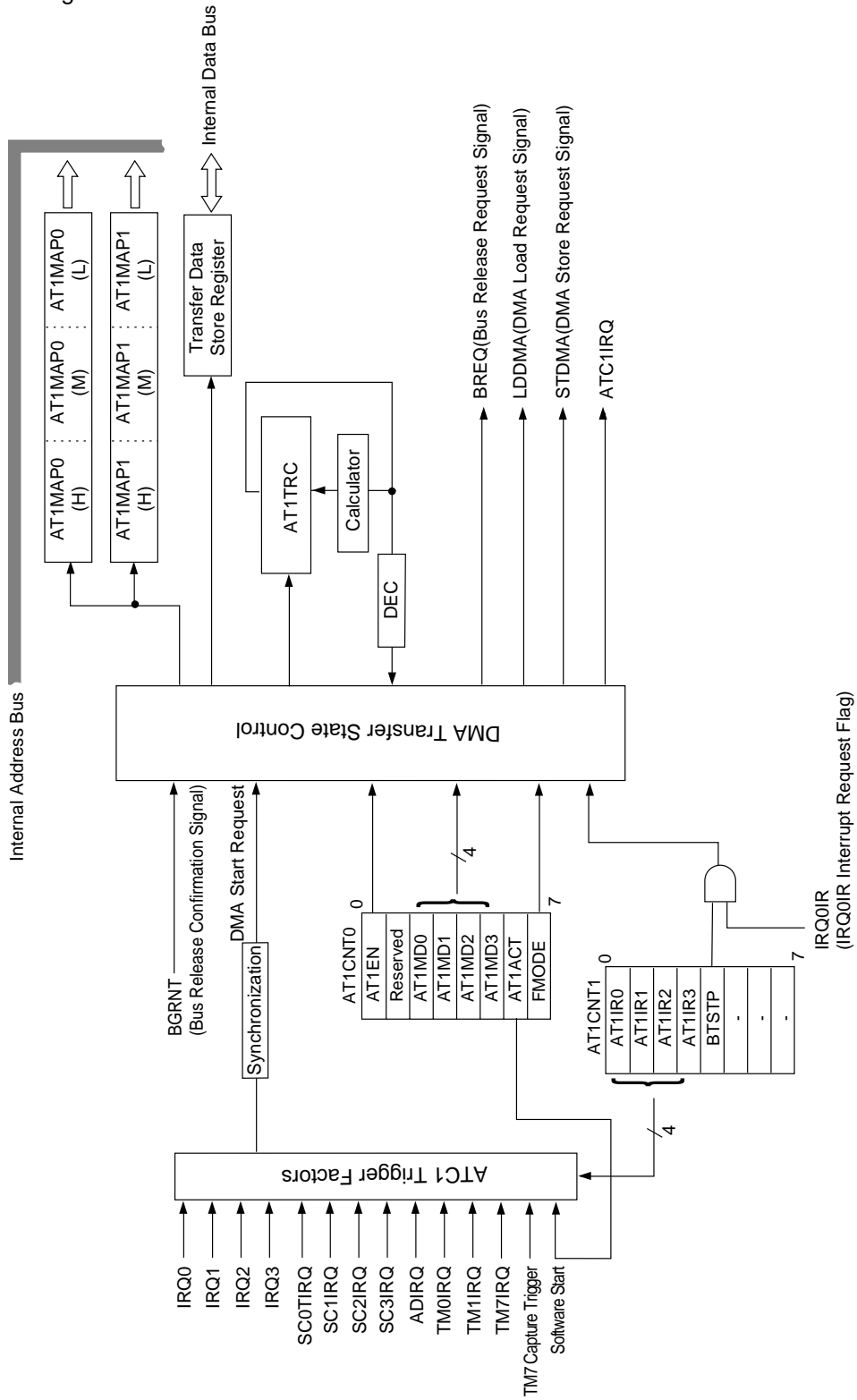


Figure 15-1-1 ATC1 Block Diagram

## 15-2 Control Registers

### 15-2-1 Registers

Table 15-2-1 shows the registers used to control ATC1.

**Table 15-2-1 ATC1 Control Registers**

	Register	Address	R/W	Function	Page
ATC1	AT1CNT0	x'03FD0'	R/W	ATC1 control register 0	XV - 6
	AT1CNT1	x'03FD1'	R/W	ATC1 control register 1	XV - 7
	AT1TRC	x'03FD2'	R/W	ATC1 transfer data counter	XV - 7
	AT1MAP0L	x'03FD3'	R/W	ATC1 memory pointer 0 (lower 8 bits)	XV - 8
	AT1MAP0M	x'03FD4'	R/W	ATC1 memory pointer 0 (middle 8 bits)	XV - 8
	AT1MAP0H	x'03FD5'	R/W	ATC1 memory pointer 0 (upper 2 bits)	XV - 8
	AT1MAP1L	x'03FD6'	R/W	ATC1 memory pointer 1 (lower 8 bits)	XV - 8
	AT1MAP1M	x'03FD7'	R/W	ATC1 memory pointer 1 (middle 8 bits)	XV - 8
	AT1MAP1H	x'03FD8'	R/W	ATC1 memory pointer 1 (upper 2 bits)	XV - 8

R/W : Readable / Writable

■ATC1 Control Register 0 (AT1CNT0)

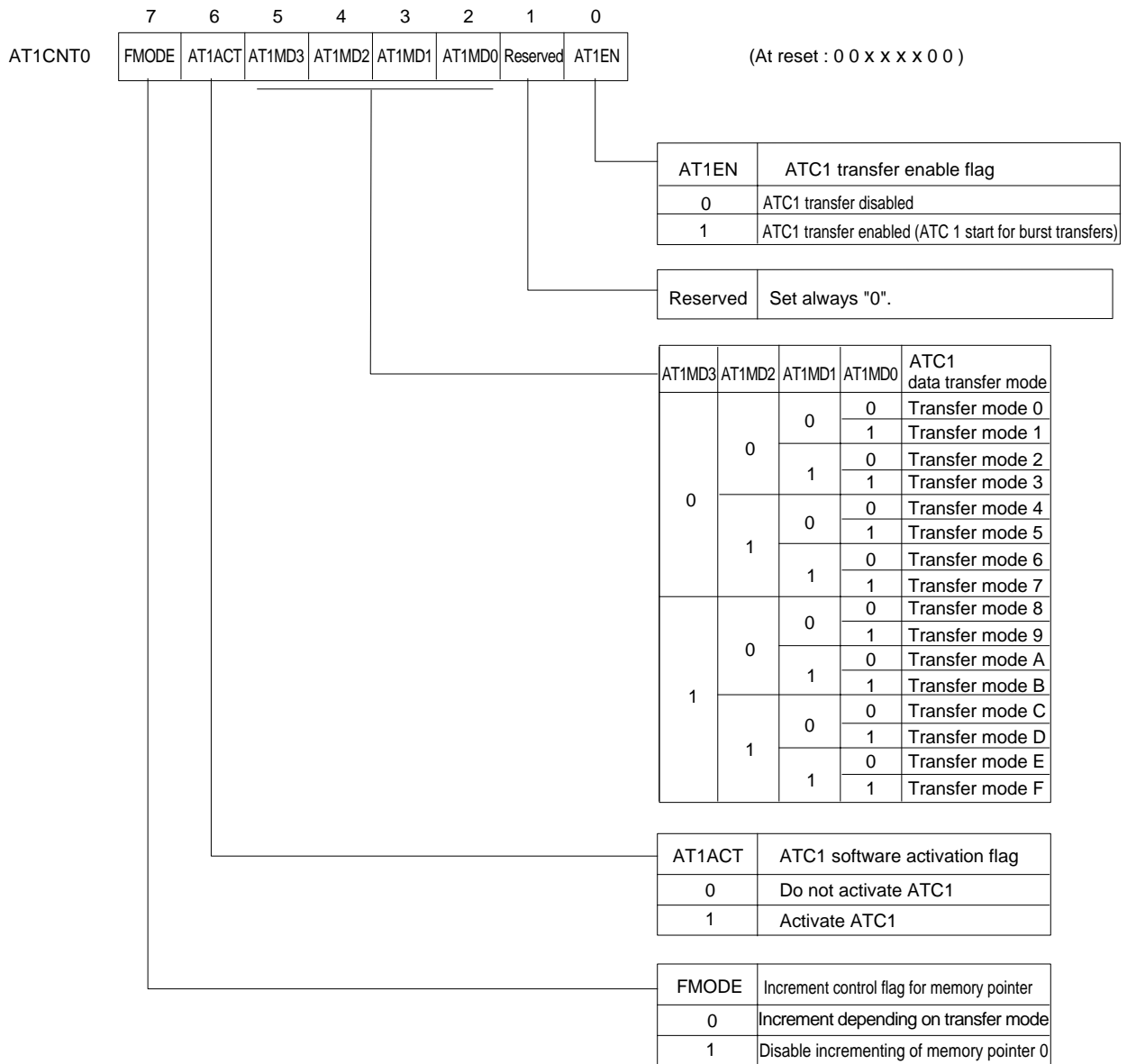


Figure 15-2-1 ATC1 Control Register 0 (AT1CNT0 : x'03FD0', R/W)

■ATC1 Control Register 1 (AT1CNT1)

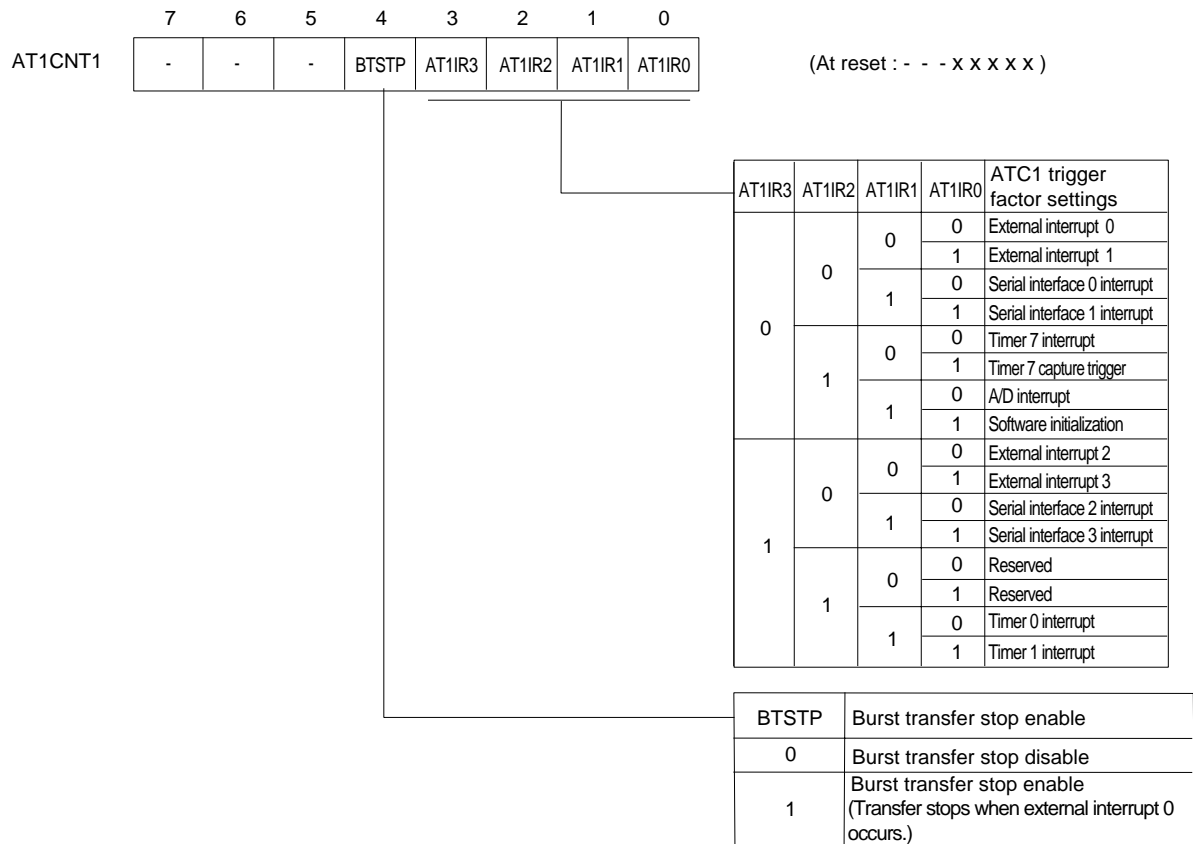


Figure 15-2-2 ATC1 Control Register 1 (AT1CNT1 : x'03FD1', R/W)

■ATC1 Transfer Counter (AT1TRC)

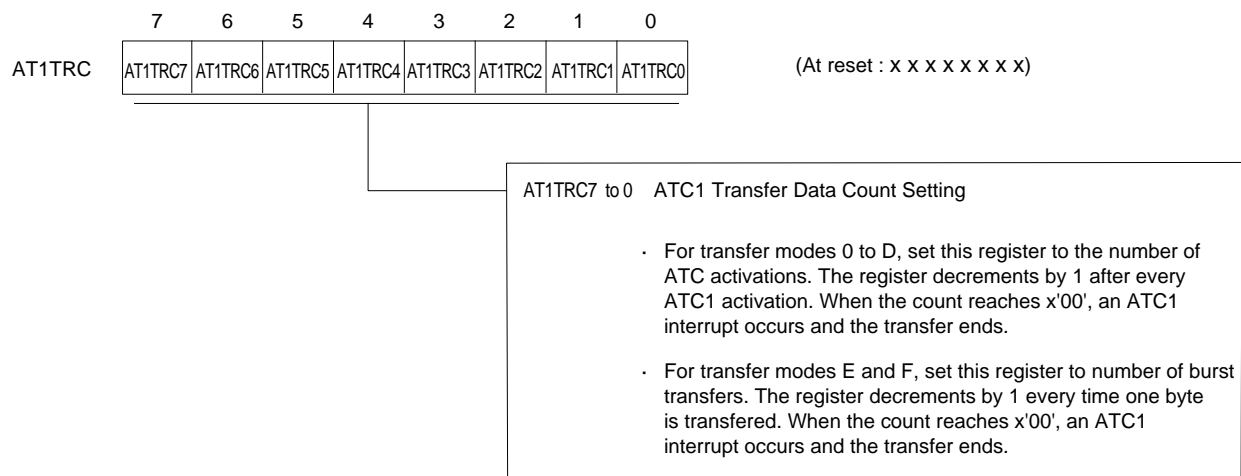
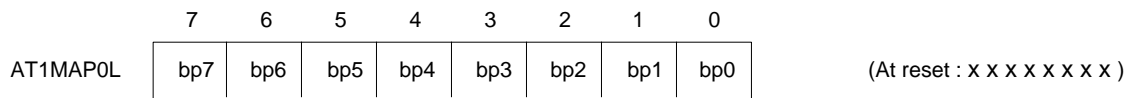
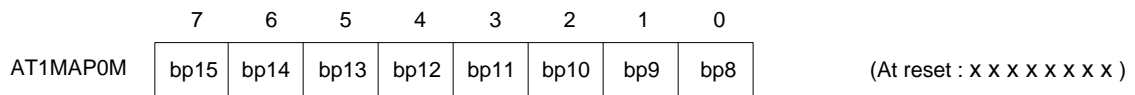


Figure 15-2-3 ATC1 Transfer Data Counter (AT1TRC : x'03FD2', R/W)

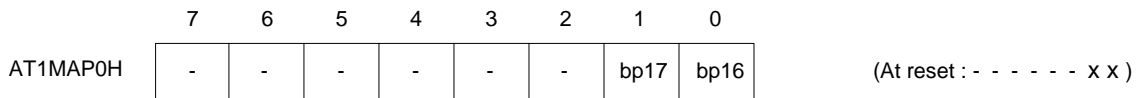
■ATC1 Memory Pointer 0 (AT1MAP0)



**Figure 15-2-4 ATC1 Memory Pointer 0 : Lower 8 bits (AT1MAP0L : x'03FD3', R/W)**

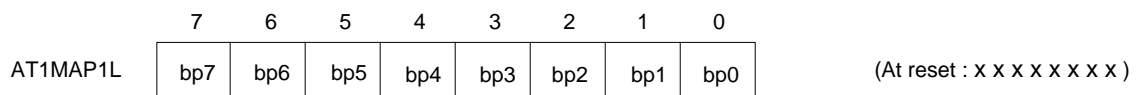


**Figure 15-2-5 ATC1 Memory Pointer 0 : Middle 8 bits (AT1MAP0M : x'03FD4', R/W)**

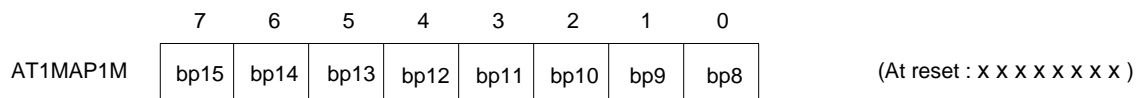


**Figure 15-2-6 ATC1 Memory Pointer 0 : Upper 2 bits (AT1MAP0H : x'03FD5', R/W)**

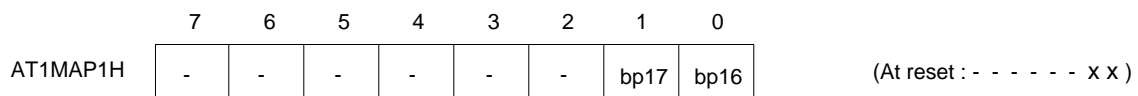
■ATC1 Memory Pointer 1 (AT1MAP1)



**Figure 15-2-7 ATC1 Memory Pointer 1 : Lower 8 bits (AT1MAP1L : x'03FD6', R/W)**



**Figure 15-2-8 ATC1 Memory Pointer 1 : Middle 8 bits (AT1MAP1M : x'03FD7', R/W)**



**Figure 15-2-9 ATC1 Memory Pointer 1 : Upper 2 bits (AT1MAP1H : x'03FD8', R/W)**



## 15-3 Operation

### 15-3-1 Basic Operations and Timing

ATC1 is a DMA block that enables the hardware to transfer the whole memory space (256 KB). This section provides a description of and timing for the basic ATC1 operations.

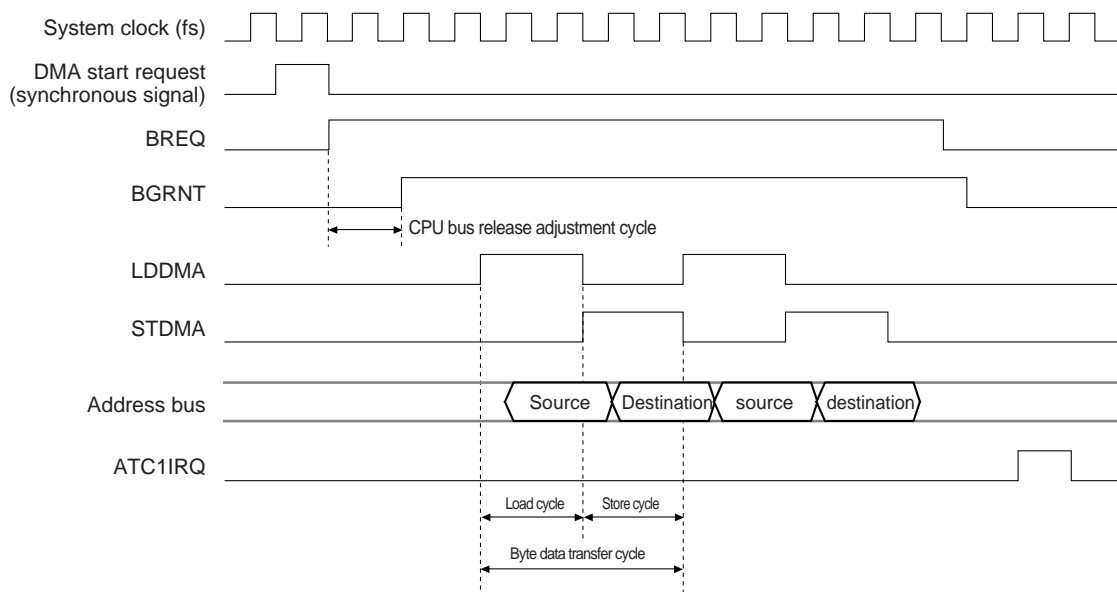


Figure 15-3-1 ATC1 Timing Chart


#### ■ ATC1 activation and internal bus acquisition

ATC1 activates either when the selected interrupt factor occurs or when the software sets the activation flag. Set the ATC1 trigger factor in ATC1 control register 1 (AT1CNT1).

When ATC1 starts, the ATC1 controller asserts the BREQ signal, which requests the MCU core to release the bus. When the core receives the BREQ signal, it stops all normal executions, even if it is in the middle of executing an instruction, and releases the bus at the next available timing. The core takes a maximum of four cycles from the time it receives the BREQ signal until it actually releases the bus. After it releases the internal bus, the core returns the bus granted signal, BGRNT, to ATC1. ATC1 can then begin using the bus to transfer data.



When an external interrupt is selected as an ATC1 trigger factor, specify the activation valid edge by the REDGn flag of the external interrupt control register, and the EDGSELn flag of the both edges interrupt control register (EDGDT).

[  Chapter 3 3-3. External interrupts]



Set the valid edge for external interrupts before ATC1 activates.

### ■Data transfer

The basic ATC1 operation cycle is the "byte-data transfer cycle", in which ATC1 transfers a single byte of data. This operation consists of two instruction cycles, a load and a store cycle. In the load cycle, ATC1 reads the data from the source address of the source memory, and in the store cycle, ATC1 stores the read data to the destination address of the destination memory.

ATC1 transfers word-length data or a multi-byte stream of data by repeating the byte-data transfer cycle as many times as necessary.

### ■Transfer end

Once it has transferred all the data, ATC1 generates an interrupt (ATC1IRQ) and stop the automatic transfer. In this way, the ATC1 block bypasses the software and automatically transfers data in a continuous DMA operation.



In both the load and store cycles, the read and write access occurs to the memory exactly as it does in a normal instruction execution. This means that the access timing is different depending on the memory space. Also, the wait settings for I/O and external memory spaces apply. The following is the access timing for each memory space, assuming no-wait situation.

- |                                 |   |
|---------------------------------|---|
| - Internal ROM/RAM space        | 2 cycles                                      |
| - External memory space         | 2 cycles                                      |
| - I/O space (special registers) | 3 cycles + CPU correction cycle (=0.5 cycles) |

The MCU core adds the CPU correction cycle (0.5 cycles) for the I/O space to correct the internal clock when it accesses a peripheral for block. It sometimes adds it and sometimes doesn't, depending on the internal state of the core.




In figure 15-3-1. ATC1 Timing Chart, the time, from the rising of DMA activation request signal to the starting of LOAD cycle depends on the state of CPU, but it takes max. 8 cycles.

## 15-3-2 Setting the Memory Address

### ■Setting the transfer addresses to the memory pointers

The address of the memory space for an automatically data transfer of ATC1 should be set in the both of memory pointer 0 (AT1MAP0) and memory pointer 1 (AT1MAP1). In each transfer mode, one of those pointer is the source address, and another is the destination address.

[  Table 15-1-2 Transfer Modes ]

### ■Memory pointer 0 functions

Memory pointer 0 is comprised of three 8-bit registers, AT1MAP0H, AT1MAP0M, and AT1MAP0L. AT1MAP0H holds upper 2bits of the 18-bit address, AT1MAP0M contains the middle 8 bits, and AT1MAP0L contains lower 8 bits. The 18-bit address set in memory pointer 0 points to a specific address in the total memory space of 256 KB.

Memory pointer 0 also contains a computational function that enables it to increment the address based on the transfer state. You can disable this function for all transfer modes by setting the FMODE bit of ATC1 control register 0 to "1".

### ■Memory pointer 1 functions

Memory pointer 1 is comprised of three 8-bit registers, AT1MAP1H, AT1MAP1M, and AT1MAP1L. AT1MAP1H holds upper 2 bits of the 18-bit address, AT1MAP1M contains the middle 8 bits, and AT1MAP1L contains lower 8 bits. Depending on the transfer mode, either all 18 bits are valid, or only the least significant 8 bits (in AT1MAP1L) are valid. When only the 8 bits in AT1MAP1L are valid, the value x'03F' is assigned to the 10 bits in AT1MAP1H and AT1MAP1M, and the pointer points to the I/O space (special registers).

Memory pointer 1 also contains a computational function that enables it to increment the address based on the transfer state.

### 15-3-3 Setting the Data Transfer Count

#### ■Transfer data counter (AT1TRC) function

You can preset the data transfer count is preset for ATC1. Set the value in the ATC1 transfer counter (AT1TRC). The counter decrements by one each time ATC1 transfers one byte of data.

The value in the transfer data counter is indeterminate upon reset. The program must initialize the counter before activating ATC1. Note that ATC1 cannot be activated if the transfer data counter is set to x'00'.

#### ■Data transfer operations using the transfer data counter (AT1TRC)

There are two main types of ATC1 data transfers, standard and burst transfers. (See section 15-3-4 "Setting the Data Transfer Modes"). The transfer counter operates differently depending on the transfer type.

##### 1. Standard transfers [transfer modes 0 to D]

In standard transfers, the transfer counter decrements every time ATC1 is activated. When the counter reaches x'00' after a data transfer, ATC1 generates an interrupt (ATC1IRQ). This means that for standard transfers, the program must set the counter to the number of times ATC1 needs to be activated.

##### 2. Burst transfers [transfer modes E to F]

In burst transfers, ATC1 is activated once and continuously transfers multiple bytes of data. In this case, the program must set the counter to the number of data bytes contained in the burst transfer. When the burst transfer starts, the transfer counter decrements every time one byte of data is transferred. When the counter reaches x'00', ATC1 generates an interrupt (ATC1IRQ).

It is also possible to force ATC1 to shut down during a burst transfer using external interrupt 0. (See 15-3-4 "Setting the Data Transfer Modes").


#### ■The transfer data counter (AT1TRC)

The transfer data counter can be set to a maximum 255 transfers (for standard transfers) or 255 bytes (for burst transfers). Note that setting the counter to x'00' disables transfers.

## 15-3-4 Setting the Data Transfer Modes

### ■Data transfer modes

There are two types of ATC1 transfers, standard and burst, and sixteen transfer modes. Set the transfer mode in ATC1 control register 0 (AT1CNT0).

[  Table 15-1-2 Transfer Modes ]

### ■Standard and burst transfers

The ATC1 transfer modes are divided into standard transfer modes and burst transfer modes. There are fourteen standard modes, 0 to D, and two burst modes, E and F.

In standard modes, the operation specified for that mode executes each time ATC1 is activated. When the transfer ends, the value set in the transfer counter (AT1TRC) decrements and bus control returns to the MCU core. This operation repeats until the transfer counter reaches x'00'. When this happens, ATC1 completes the final data transfer, then generates an interrupt (ATC1IRQ).

For instance, if the initial transfer counter value is x'05', and the ATC1 activation factor is set to a timer 0 interrupt, ATC1 is activated each time timer 0 overflows and the automatic transfer begins. After fifth data transfers (activated by fifth timer 0 overflow) is complete, the transfer counter value becomes x'00', an ATC1 interrupt occurs, and the operation ends. Timer 0 overflows occurring after this point do not activate ATC1. For standard transfers, the program must set the transfer counter to the number of ATC1 activations required.

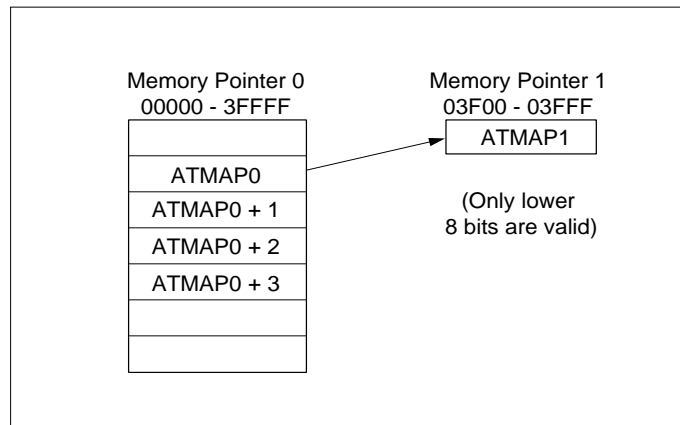
In burst modes, once ATC1 is activated, it transfers in one operation the number of bytes set in the transfer counter (AT1TRC). After the burst transfer begins, the transfer counter decrements each time ATC1 transfers one byte of data. When the counter reaches x'00', ATC1 generates an interrupt (ATC1IRQ) and the burst transfer ends. For burst transfers, the program must set the transfer counter to the number of data bytes in the burst transfer.

An external interrupt 0 can also be used to shut down ATC1 during a burst transfer. To enable this function, set the burst transfer stop enable bit (BTSTP) in ATC1 control register 1 (AT1CNT1) to 1.

When BTSTP = 1, ATC1 data transfers stop when the external interrupt 0 interrupt request flag (IRQ0IR flag in the IRQ0ICR register) is set. In an emergency shutdown, the transfer counter and memory pointer save the values they contained prior to the shutdown. When the interrupt service routine ends, a new activation factor restarts ATC1, and the burst transfer begins transferring data from the point at which it stopped.

### 15-3-5 Transfer Mode 0

In transfer mode 0, ATC1 automatically transfers one byte of data from any memory space to the I/O space (special registers : x'03F00' - x'03FFF') every time an ATC1 activation request occurs.



**Figure 15-3-2 Transfer Mode 0**

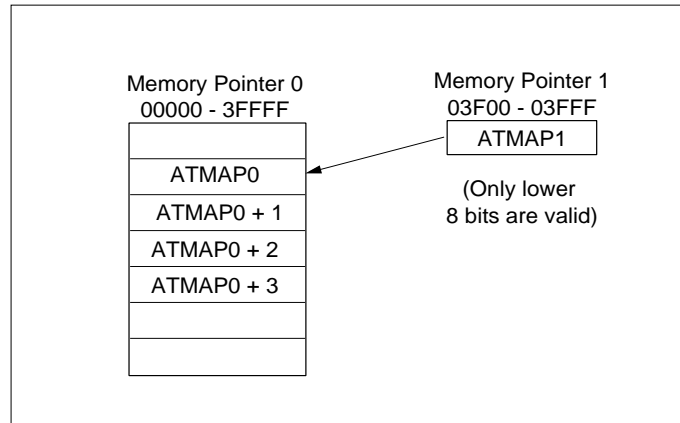
Set the source address in 18-bit memory pointer 0 (AT1MAP0H, M, L), and set the destination I/O address in lower 8 bits of memory pointer 1(AT1MAP1L). The upper 10 bits of the I/O space address (x'03F') need not to be set in AT1MAP1H and AT1MAP1M.

Transfer mode 0 does not have an incrementing function for the memory pointers. The data transfer executes for a fixed address.

Set the data transfer count for ATC1 in the transfer data counter (AT1TRC). The counter can be set to a maximum of 255 transfers. The counter decrements each time ATC1 is activated. When it reaches x'00', an interrupt (ATC1IRQ) occurs and the automatic transfer ends.

## 15-3-6 Transfer Mode 1

In transfer mode 1, ATC1 automatically transfers one byte of data from the I/O space (special registers : x'03F00' - x'03FFF') to any memory space every time an ATC1 activation request occurs.



**Figure 15-3-3 Transfer Mode 1**

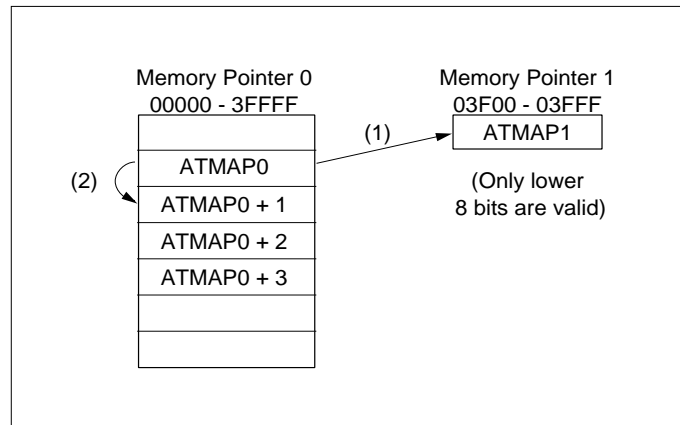
Set the source I/O address in lower 8 bits of memory pointer 1 (AT1MAP1L), and set the destination address in 18-bit memory pointer 0 (AT1MAP0H, M, L). The upper 10 bits of the I/O space address (x'03F') need not to be set in AT1MAP1H and AT1MAP1M.

Transfer mode 1 does not have an incrementing function for the memory pointers. The data transfer executes for a fixed address.

Set the data transfer count for ATC1 in the transfer data counter (AT1TRC). The counter can be set to a maximum of 255 transfers. The counter decrements each time ATC1 is activated. When it reaches x'00', an interrupt (ATC1IRQ) occurs and the automatic transfer ends.

### 15-3-7 Transfer Mode 2

In transfer mode 2, ATC1 automatically transfers one byte of data from any memory space to the I/O space (special registers : x'03F00' - x'03FFF') every time an ATC1 activation request occurs.



**Figure 15-3-4 Transfer Mode 2**

Set the source address in 18-bit memory pointer 0 (AT1MAP0H, M, L), and set the destination I/O address in lower 8 bits of memory pointer 1(AT1MAP1L). The upper 10 bits of the I/O space address (x'03F') need not to be set in AT1MAP1H and AT1MAP1M.

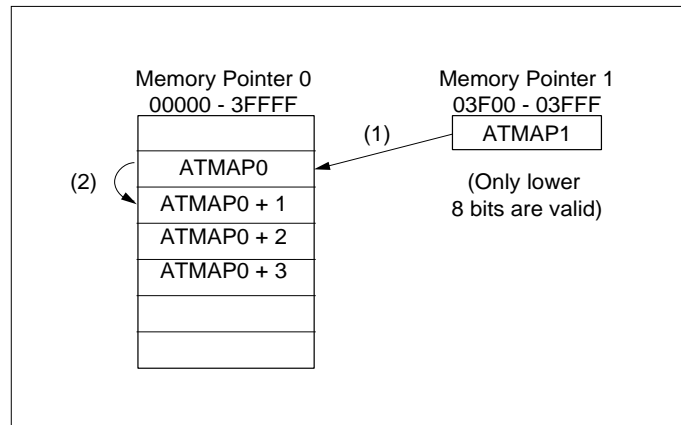
In transfer mode 2, the value in memory pointer 0 increments by 1 each time a byte-length data transfer ends. As a result, the source address for the next transfer is one address higher than that for the previous transfer.

Set the data transfer count for ATC1 in the transfer data counter (AT1TRC). The counter can be set to a maximum of 255 transfers. The counter decrements each time ATC1 is activated. When it reaches x'00', an interrupt (ATC1IRQ) occurs and the automatic transfer ends.



### 15-3-8 Transfer Mode 3

In transfer mode 3, ATC1 automatically transfers one byte of data from the I/O space (special registers : x'03F00' - x'03FFF') to any memory space every time an ATC1 activation request occurs.



**Figure 15-3-5 Transfer Mode 3**

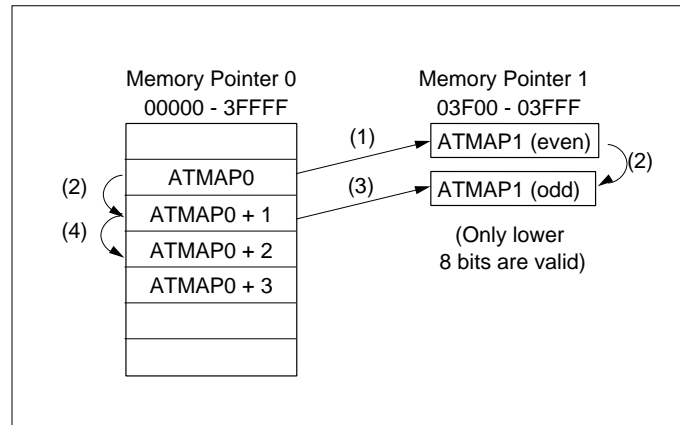
Set the source I/O address in lower 8 bits of memory pointer 1 (AT1MAP1L), and set the destination address in 18-bit memory pointer 0 (AT1MAP0H, M, L). The upper 10 bits of the I/O space address (x'03F') need not to be set in AT1MAP1H and AT1MAP1M.

In transfer mode 3, the value in memory pointer 0 increments by 1 each time a byte-length data transfer ends. As a result, the destination address for the next transfer is one address higher than that for the previous transfer.

Set the data transfer count for ATC1 in the transfer data counter (AT1TRC). The counter can be set to a maximum of 255 transfers. The counter decrements each time ATC1 is activated. When it reaches x'00', an interrupt (ATC1IRQ) occurs and the automatic transfer ends.

## 15-3-9 Transfer Mode 4

In transfer mode 4, ATC1 automatically transfers two bytes (one word) of data from any memory space to the I/O space (special registers : x'03F00' - x'03FFF') every time an ATC1 activation request occurs.



**Figure 15-3-6 Transfer Mode 4**

Set the source address in 18-bit memory pointer 0 (AT1MAP0H, M, L), and set the destination I/O address in the lower 8 bits of memory pointer 1 (AT1MAP1L). The upper 10 bits of the I/O space address (x'03F') need not to be set in AT1MAP1H and AT1MAP1M.



Always set an even address as the destination I/O address in memory pointer 1. When ATC1 transfers one word to the I/O space, ATC1 can transfer the even address set in memory pointer 1 and the odd address that immediately follows it.

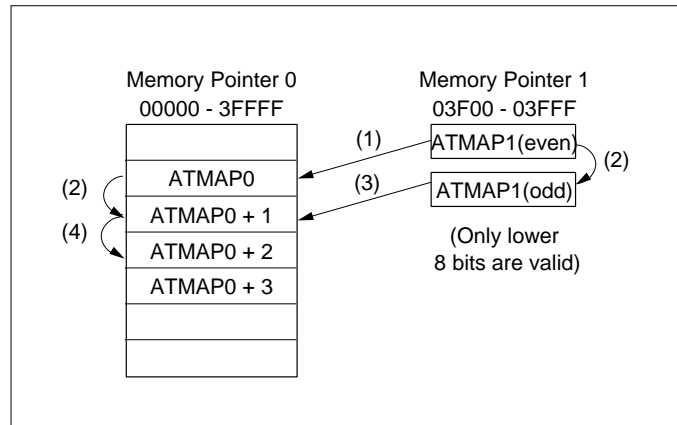
In transfer mode 4, ATC1 executes a data byte transfer twice, to send one data word, each time it is activated. The value in memory pointer 0 increments by one each time a byte-length data transfer ends. As a result, the source address for the next ATC1 operation is two addresses higher than that for the previous operation.

In this word-length transfer, ATC1 transfers the first data byte to an even address in the I/O space and the second data byte to an odd address in the I/O space.

Set the data transfer data count for ATC1 in the transfer data counter (AT1TRC). The counter can be set to a maximum of 255 transfers. The counter decrements each time ATC1 is activated (after each *word* transfer). When it reaches x'00', an interrupt (ATC1IRQ) occurs and the automatic transfer ends.

### 15-3-10 Transfer Mode 5

In transfer mode 5, ATC1 automatically transfers two bytes (one word) of data from the I/O space (special registers : x'03F00' - x'03FFF') to any memory space every time an ATC1 activation request occurs.



**Figure 15-3-7 Transfer Mode 5**

Set the source I/O address in lower 8 bits of memory pointer 1 (AT1MAP1L), and set the destination address in 18-bit memory pointer 0 (AT1MAP0H, M, L). The upper 10 bits of the I/O space address (x'03F') need not to be set in AT1MAP1H and AT1MAP1M.



Always set an even address as the source I/O address in memory pointer 1. When ATC1 transfers one word from the I/O space, ATC1 can transfer the even address set in memory pointer 1 and the odd address that immediately follows it.

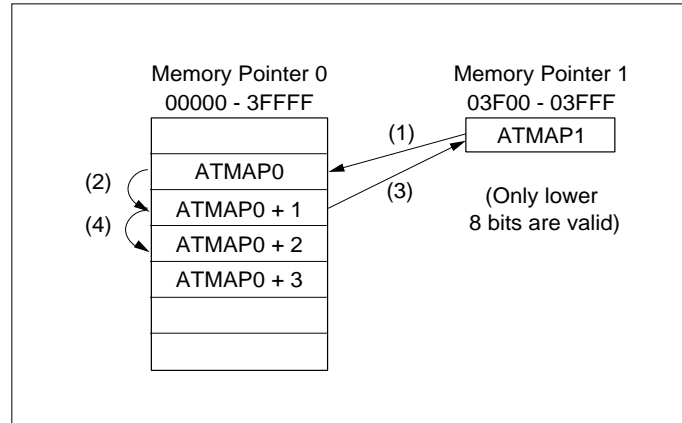
In transfer mode 5, ATC1 executes a data byte transfer twice, to send one data word, each time it is activated. The value in memory pointer 0 increments by one each time a byte-length data transfer ends. As a result, the destination address for the next ATC1 operation is two addresses higher than that for the previous operation.

In this word-length transfer, ATC1 transfers the first data byte from an even address in the I/O space and the second data byte from an odd address in the I/O space.

Set the data transfer count for ATC1 in the transfer data counter (AT1TRC). The counter can be set to a maximum of 255 transfers. The counter decrements each time ATC1 is activated (after each *word* transfer). When it reaches x'00', an interrupt (ATC1IRQ) occurs and the automatic transfer ends.

### 15-3-11 Transfer Mode 6

In transfer mode 6, ATC1 automatically transfers one byte of data two times every time an ATC1 activation request occurs.



**Figure 15-3-8 Transfer Mode 6**

In this mode the transfer direction indicated by memory pointers 0 and 1 reverses for the second data byte transfer.

In the first data byte transfer, the I/O space address (x'03F00' - x'03FFF') in memory pointer 1 is the source address, and the address in memory pointer 0, for any memory space, is the destination address. When the first data byte transfer ends, the address in memory pointer 0 increments by one.

In the second data byte transfer, the incremented address in memory pointer 0 becomes the source address, and the I/O space address (x'03F00' - x'03FFF') in memory pointer 1 becomes the destination address. When the second data byte transfer ends, the address in memory pointer 0 increments again.

Set the I/O address in lower 8 bits of memory pointer 1 (AT1MAP1L). The upper 10 bits of the I/O space address (x'03F') need not to be set in AT1MAP1H, AT1MAP1M.



Transfer mode 6 can be used to support continuous transmission/reception for serial interface 2 and 3. Set memory pointer 1 to point to the serial transmission/reception shift register (SCnTRB) and select serial interrupts as an ATC1 trigger factor. In this way, each time a serial communication ends the MCU continuously reads the received data (first data byte transfer) then writes the transmission data (second data byte transfer) up to 255 times, entirely through the hardware.



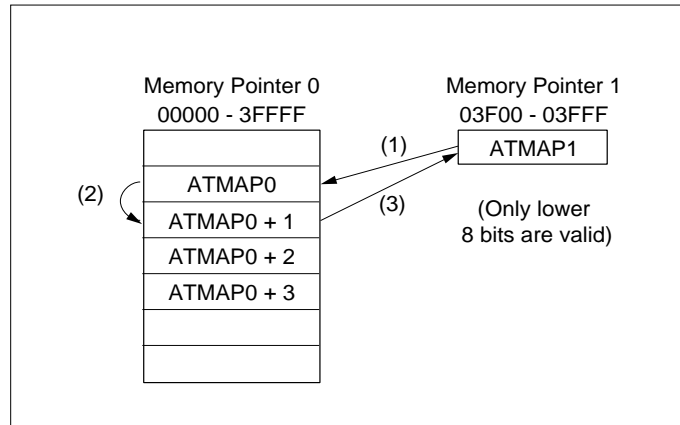
To execute a continuous serial transaction, you must pre-store the serial transmission data in the memory space that memory pointer 0 points, the transmission data must fill every other address in the space. Once the serial transaction ends, the received data is stored empty (skipped) addresses and the transmission and reception data at stored in an alternating pattern.

In transfer mode 6, ATC1 executes a data byte transfer twice each time it is activated. The value in memory pointer 0 increments by one each time a byte-length data transfer ends. As a result, the source address for the next ATC1 operation is two addresses higher than that for the previous operation.

Set the data transfer count for ATC1 in the transfer data counter (AT1TRC). The counter can be set to a maximum of 255 transfers. The counter decrements each time ATC1 is activated (after one byte of data has been transferred twice). When it reaches x'00', an interrupt (ATC1IRQ) occurs and the automatic transfer ends.

## 15-3-12 Transfer Mode 7

In transfer mode 7, ATC1 automatically transfers one byte of data two times every time an ATC1 activation request occurs.



**Figure 15-3-9 Transfer Mode 7**

In this mode the transfer direction indicated by memory pointers 0 and 1 reverses for the second data byte transfer.

In the first data byte transfer, the I/O space address (x'03F00' - x'03FFF') in memory pointer 1 is the source address, and the address in memory pointer 0, for any memory space, is the destination address. When the first data byte transfer ends, the address in memory pointer 0 increments by one.

In the second data byte transfer, the incremented address in memory pointer 0 becomes the source address, and the I/O space address (x'03F00' - x'03FFF') in memory pointer 1 becomes the destination address. The address in memory pointer 0 remains unchanged after the second data byte transfer ends.

Set the I/O address in lower 8 bits of memory pointer 1 (AT1MAP1L). The upper 10 bits of the I/O space address (x'03F') need not to be set in AT1MAP1H, AT1MAP1M.



Transfer mode 7 can be used to support continuous transmission/reception for serial interface 2 and 3. Set memory pointer 1 to point to the serial transmission/reception shift register (SCnTRB) and select serial interrupts as an ATC1 trigger factor. In this way, each time a serial communication ends the MCU continuously reads the reception data (first data byte transfer) then writes the transmission data (second data byte transfer) up to 255 times, entirely through the hardware.



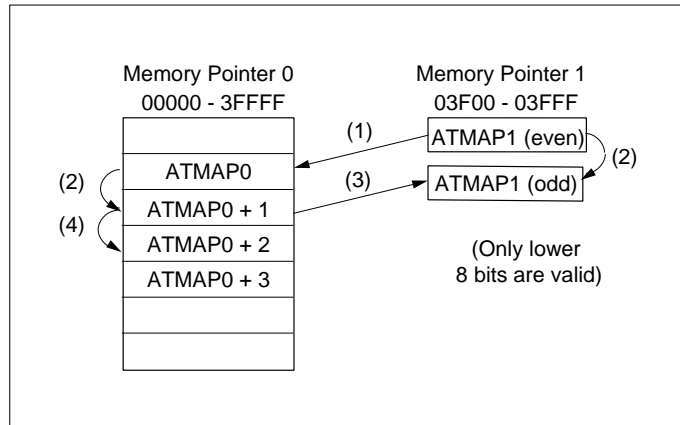
To execute a continuous serial transaction, you must pre-store the serial transmission data in the memory space that memory pointer 0 points, once the serial communication ends, the MCU has written to the reception data over the transmission data, so that only reception data remains in the memory.

In transfer mode 7, ATC1 executes a data byte transfer twice each time it is activated. However, the value in memory pointer 0 increments by one only after the first transfer ends. As a result, the source address for the next ATC1 operation is one address higher than that for the previous operation.

Set the data transfer count for ATC1 in the transfer data counter (AT1TRC). The counter can be set to a maximum of 255 transfers. The counter decrements each time ATC1 is activated (after one byte of data has been transferred twice). When it reaches x'00', an interrupt (ATC1IRQ) occurs and the automatic transfer ends.

### 15-3-13 Transfer Mode 8

In transfer mode 8, ATC1 automatically transfers one byte of data two times every time an ATC1 activation request occurs.



**Figure 15-3-10 Transfer Mode 8**

In this mode the transfer direction indicated by memory pointers 0 and 1 reverses for the second data byte transfer.

In the first data byte transfer, the I/O space address (x'03F00' - x'03FFF') in memory pointer 1 is the source address, and the address in memory pointer 0, for any memory space, is the destination address. When the first data byte transfer ends, the address in memory pointer 0 increments by one.

In the second data byte transfer, the incremented address in memory pointer 0 becomes the source address, and the I/O space address (x'03F00' - x'03FFF') in memory pointer 1 becomes the destination address. When the second data byte transfer ends, the address in memory pointer 0 increments again.

Set an even I/O address in the lower 8 bits of memory pointer 1 (AT1MAP1L). The upper 10 bits of the I/O space address (x'03F') need not to be set in AT1MAP1H, AT1MAP1M.



Always set an even I/O address in memory pointer 1. In this double transfer of a data byte from and to the I/O space, ATC1 targets the even I/O address set in memory pointer 1 and the odd address that immediately follows it. In this mode, the first data byte transfer accesses an even I/O address and the second data byte transfer accesses an odd I/O address.





Transfer mode 8 can be used to support continuous transmission/ reception for serial interface 0 and 1. Set the memory pointer 1 to point to the serial reception buffer (RXBUF0, RXBUF1) and select serial interrupts as the ATC1 trigger factor. In this way, each the serial communication ends, the MCU continuously reads the reception data (first data byte transfer), then writes the transmission data to the transmission buffer (TXBUF0, TXBUF1) (second data byte transfer) up to 255 times, entirely through the hardware.



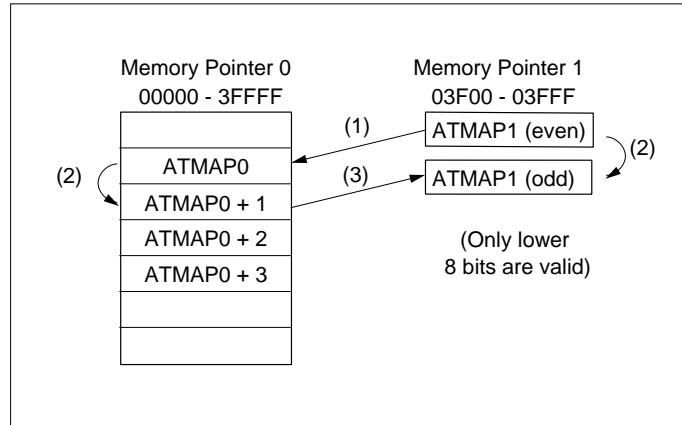
Before execute a continuous serial transaction, store the serial transmission data in the memory space that memory pointer 0 points, the transmission data must fill every other address in the space. Once the serial transaction ends, the received data is stored empty (skipped) addresses and the transmission and reception data at stored in an alternating pattern.

In transfer mode 8, ATC1 executes a data byte transfer twice each time it is activated. The value in memory pointer 0 increments by one each time a byte-length data transfer ends. As a result, the source address for the next ATC1 operation is two addresses higher than that for the previous operation.

Set the data transfer count for ATC1 in the transfer data counter (AT1TRC). You can set the counter to a maximum of 255 transfers. The counter decrements each time ATC1 is activated (after one byte of data has been transferred twice). When it reaches x'00', an interrupt (ATC1IRQ) occurs and the automatic transfer ends.

### 15-3-14 Transfer Mode 9

In transfer mode 9, ATC1 automatically transfers one byte of data two times every time an ATC1 activation request occurs.



**Figure 15-3-11 Transfer Mode 9**

In this mode the transfer direction indicated by memory pointers 0 and 1 reverses for the second data byte transfer.

In the first data byte transfer, the I/O space address (x'03F00' - x'03FFF') in memory pointer 1 is the source address, and the address in memory pointer 0, for any memory space, is the destination address. When the first data byte transfer ends, the address in memory pointer 0 increments by one.

In the second data byte transfer, the incremented address in memory pointer 0 becomes the source address, and the I/O space address (x'03F00' - x'03FFF') in memory pointer 1 becomes the destination address. The address in memory pointer 0 remains unchanged after the second data byte transfer ends.

Set an even I/O address in lower 8 bits of memory pointer 1 (AT1MAP1L). The upper 10 bits of the I/O space address (x'03F') need not to be set in AT1MAP1H, AT1MAP1M.



Always set an even I/O address in memory pointer 1. In this double transfer of a data byte from and to the I/O space, ATC1 targets the even I/O address set in memory pointer 1 and the odd address that immediately follows it. In this mode, the first data byte transfer accesses an even I/O address and the second data byte transfer accesses an odd I/O address.



Transfer mode 9 can be used to support continuous transmission/ reception for serial interface 0 and 1. Set the memory pointer 1 to point to the serial reception buffer (RXBUF0, RXBUF1) and select serial interrupts as the ATC1 trigger factor. In this way, each the serial communication ends, the MCU continuously reads the reception data (first data byte transfer), then writes the transmission data to the transmission buffer (TXBUF0, TXBUF1) (second data byte transfer) up to 255 times, entirely through the hardware.



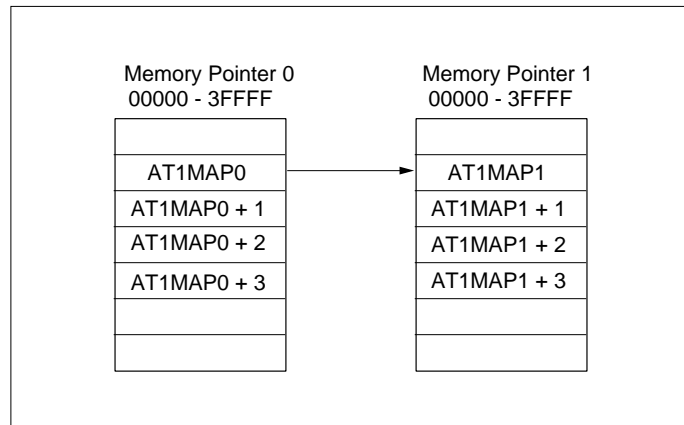
Before execute a continuous serial transaction, store the serial transmission data in the memory space that memory pointer 0 points, once the serial communication ends, the MCU has written to the reception data over the transmission data, so that only reception data remains in the memory.

In transfer mode 9, ATC1 executes a data byte transfer twice each time it is activated. However, the value in memory pointer 0 increments by one only after the first transfer ends. As a result, the source address for the next ATC1 operation is one address higher than that for the previous operation.

Set the data transfer count for ATC1 in the transfer data counter (AT1TRC). The counter can be set to a maximum of 255 transfers. The counter decrements each time ATC1 is activated (after one byte of data has been transferred twice). When it reaches x'00', an interrupt (ATC1IRQ) occurs and the automatic transfer ends.

### 15-3-15 Transfer mode A

In transfer mode A, ATC1 automatically transfers one byte of data from any memory space to any other memory space every time an ATC1 activation request occurs.



**Figure 15-3-12 Transfer Mode A**

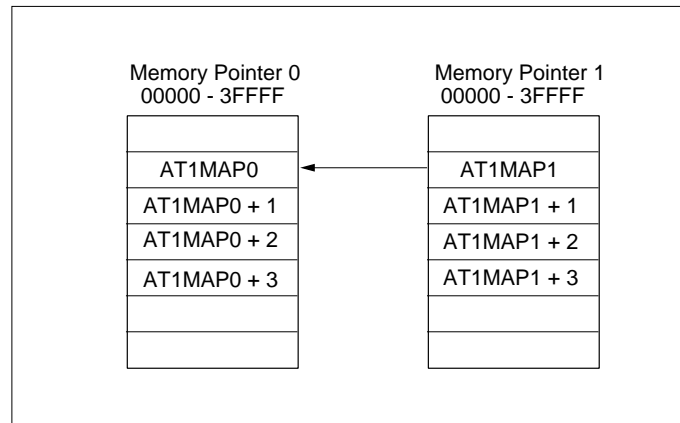
Set the source address in 18-bit memory pointer 0 (AT1MAP0H, M, L), and set the destination address in 18-bit memory pointer 1 (AT1MAP0H, M, L).

Transfer mode A does not have an incrementing function for the memory pointers. The data transfer executes for a fixed address.

Set the data transfer count for ATC1 in the transfer data counter (AT1TRC). The counter can be set to a maximum of 255 transfers. The counter decrements each time ATC1 is activated. When it reaches x'00', an interrupt (ATC1IRQ) occurs and the automatic transfer ends.

## 15-3-16 Transfer Mode B

In transfer mode B, ATC1 automatically transfers one byte of data from any memory space to any other memory space every time an ATC1 activation request occurs.



**Figure 15-3-13 Transfer Mode B**

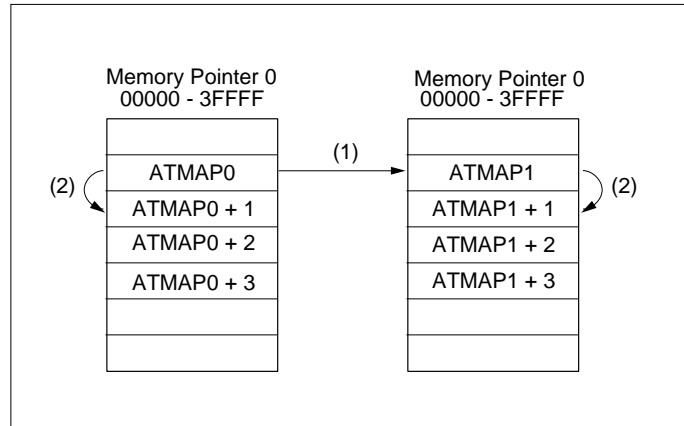
Set the source address in 18-bit memory pointer 1 (AT1MAP1H, M, L), and set the destination address in 18-bit memory pointer 0 (AT1MAP0H, M, L).

Transfer mode B does not have an incrementing function for the memory pointers. The data transfer executes for a fixed address.

Set the data transfer count for ATC1 in the transfer data counter (AT1TRC). The counter can be set to a maximum of 255 transfers. The counter decrements each time ATC1 is activated. When it reaches x'00', an interrupt (ATC1IRQ) occurs and the automatic transfer ends.

### 15-3-17 Transfer Mode C

In transfer mode C, ATC1 automatically transfers one byte of data from any memory space to any other memory space every time an ATC1 activation request occurs.



**Figure 15-3-14 Transfer Mode C**

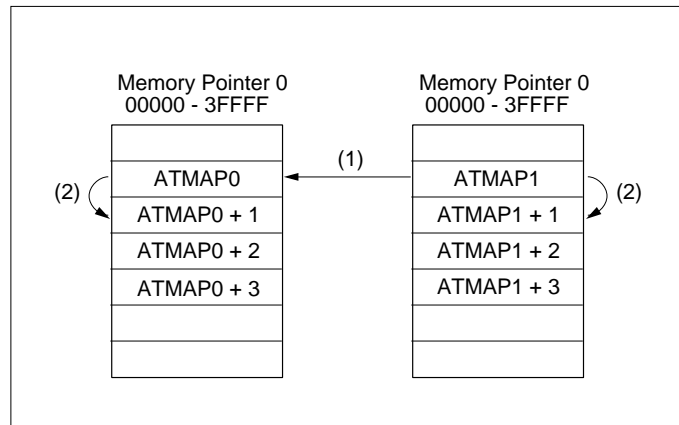
Set the source address in 18-bit memory pointer 0 (AT1MAP0H, M, L), and set the destination address in 18-bit memory pointer 1 (AT1MAP1H, M, L).

In transfer mode C, the values in memory pointers 0 and 1 increment by 1 each time a byte-length data transfer ends. As a result, the source and destination addresses for the next transfer are one address higher than those for the original transfer.

Set the data transfer count for ATC1 in the transfer data counter (AT1TRC). The counter can be set to a maximum of 255 transfers. The counter decrements each time ATC1 is activated. When it reaches '00', an interrupt (ATC1IRQ) occurs and the automatic transfer ends.

### 15-3-18 Transfer Mode D

In transfer mode D, ATC1 automatically transfers one byte of data from any memory space to any other memory space every time an ATC1 activation request occurs.



**Figure 15-3-15 Transfer Mode D**

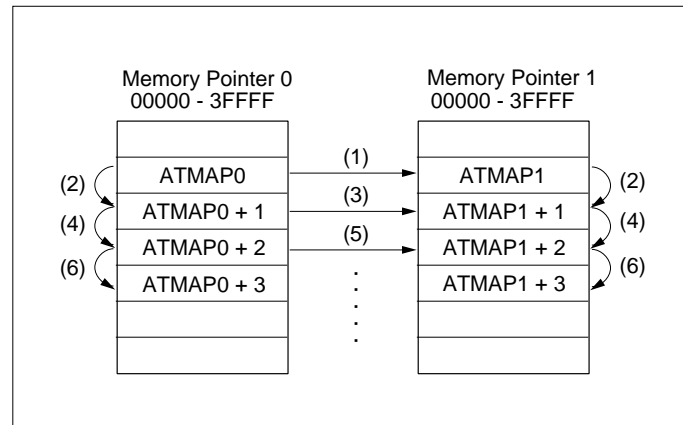
Set the source address in 18-bit memory pointer 1 (AT1MAP1H, M, L), and set the destination address in 18-bit memory pointer 0 (AT1MAP0H, M, L).

In transfer mode D, the values in memory pointers 0 and 1 increment by 1 each time a byte-length data transfer ends. As a result, the source and destination addresses for the next transfer are one address higher than those for the original transfer.

Set the data transfer count for ATC1 in the transfer data counter (AT1TRC). The counter can be set to a maximum of 255 transfers. The counter decrements each time ATC1 is activated. When it reaches x'00', an interrupt (ATC1IRQ) occurs and the automatic transfer ends.

### 15-3-19 Transfer Mode E

Transfer mode E is a burst mode. In this mode, when ATC1 is activated, it automatically transfers the number of data bytes set in the transfer data counter (AT1TRC) in one continuous operation.



**Figure 15-3-16 Transfer Mode E**

Set the source address in 18-bit memory pointer 0 (AT1MAP0H, M, L), and set the destination address in 18-bit memory pointer 1 (AT1MAP1H, M, L). Once ATC1 is activated, memory pointers 0 and 1 increment by one each a byte-length data transfer ends.

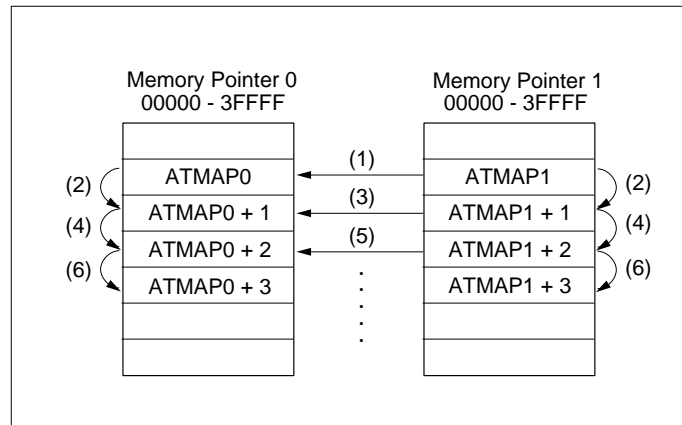
For burst transfers, set the number of data bytes to be transferred in the transfer data counter (AT1TRC). The counter can be set to a maximum of 255 bytes. Once the burst transfer starts, the counter decrements each time ATC1 transfers one byte of data. When it reaches 'x'00', an interrupt (ATC1IRQ) occurs and the burst transfer ends.

It is possible to shut down ATC1 during burst transfers using external interrupt 0. You can enable or disable ATC1 shutdown with the burst transfer stop enable flag (BSTP) of ATC1 control register 1 (AT1CNT1). When BSTP=1 and the interrupt request flag for external interrupt 0 (the IRQ0IR flag in the IRQ0ICR register) is set, the ATC1 data transfer shuts down immediately. During this shutdown, the transfer counter and the memory pointers save the values they contained prior to the shutdown. When the interrupt service routine ends and a new ATC1 trigger factor occurs, the burst transfer restarts from the point at which it stopped.



## 15-3-20 Transfer Mode F

Transfer mode F is a burst mode. In this mode, when ATC1 is activated, it automatically transfers the number of data bytes set in the transfer data counter (AT1TRC) in one continuous operation.



**Figure 15-3-17 Transfer Mode F**

Set the source address in 18-bit memory pointer 1 (AT1MAP1H, M, L), and set the destination address in 18-bit memory pointer 0 (AT1MAP0H, M, L). Once ATC1 is activated, memory pointers 0 and 1 increment by one each a byte-length data transfer ends.

For burst transfers, set the number of data bytes to be transferred in the transfer data counter (AT1TRC). The counter can be set to a maximum of 255 bytes. Once the burst transfer starts, the counter decrements each time ATC1 transfers one byte of data. When it reaches 'x'00', an interrupt (ATC1IRQ) occurs and the burst transfer ends.

It is possible to shut down ATC1 during burst transfers using external interrupt 0. You can enable or disable ATC1 shutdown with the burst transfer stop enable flag (BSTP) of ATC1 control register 1 (AT1CNT1). When BSTP=1 and the interrupt request flag for external interrupt 0 (the IRQ0IR flag in the IRQ0ICR register) is set, the ATC1 data transfer shuts down immediately. During this shutdown, the transfer counter and the memory pointers save the values they contained prior to the shutdown. When the interrupt service routine ends and a new ATC1 trigger factor occurs, the burst transfer restarts from the point at which it stopped.

## 15-4 Setup Example

An example setup procedure, with a description of each step is as follows ;

Setup Procedure	Description
(1) Set the data transfer mode. AT1CNT0 (x'3FD0') bp7       :FMODE bp6       :AT1ACT   = 0 bp5-2     :AT1MD3-0 bp0       :AT1EN     = 0	(1) Select the data transfer mode with the AT1MD flag in the AT1CNT0 register. No matter which mode you select, setting the FMODE flag disables the incrementing function in memory pointer 0. Normally set this flag to 0. Note that you must set the ATC1 enable flag, AT1EN, to 0 at this step. Only enable ATC1 after setting all the other registers.
(2) Set memory pointer 0. AT1MAP0L (x'3FD3') AT1MAP0M (x'3FD4') AT1MAP0H (x'3FD5')	(2) Depending on the transfer mode you selected, set the source or destination address in the AT1MAP0 registers.
(3) Set memory pointer 1. AT1MAP1L (x'3FD6') AT1MAP1M (x'3FD7') AT1MAP1H (x'3FD8')	(3) Depending on the transfer mode you selected, set the source or destination address in the AT1MAP1 registers.
(4) Set the transfer data counter. AT1TRC (x'3FD2')	(4) Set the ATC1 data transfer count in the AT1TRC register.
(5) Select the ATC1 activation factor. AT1CNT1 (x'3FD1') bp4       :BTSTP bp3-0     :AT1IR3-0	(5) Select the ATC1 activation factor with the AT1IR flag in the AT1CNT1 register. If you select a burst-type transfer mode, then you must also enable or disable ATC1 shutdown at this step, by setting the BTSTP.
(6) Enable ATC operation. AT1CNT0 (x'3FD0') bp0       :AT1EN     = 1	(6) Enable ATC1 data transfers with the AT1EN flag in the AT1CNT0 register.



To activate ATC1 in the software, first complete steps (1) to (6), then set the AT1ACT flag in the AT1CNT0 register. After the AT1ACT flag is set, ATC1 is started and data transfer is started. The hardware automatically clears AT1ACT flag when ATC1 is activated. On the standard transfer mode, set a program that sets flags as much as the data transfer needs.





## 16-1 Overview

This LSI has an A/D converter with 10 bits resolution. That has a built-in sample hold circuit, and software can switch channel 0 to 7 (AN0 to AN7) to analog input. As A/D converter is stopped, the power consumption can be reduced by a built-in ladder resistance. A/D converter is activated by 2 factors : a register setup or an external interrupt.

### 16-1-1 Functions

Table 16-1-1 shows the A/D converter functions.

**Table 16-1-1 A/D Converter Functions**

A/D Input Pins	8 pins
Pins	AN7 to AN0
Interrupt	ADIRQ
Resolution	10 bits
Conversion Time (Min.)	9.6 $\mu$ s( $T_{AD}$ = as 800 ns)
Input range	VREF- to VREF+
Power Consumption	Built-in Ladder Resistance (ON/OFF)

### 16-1-2 Block Diagram

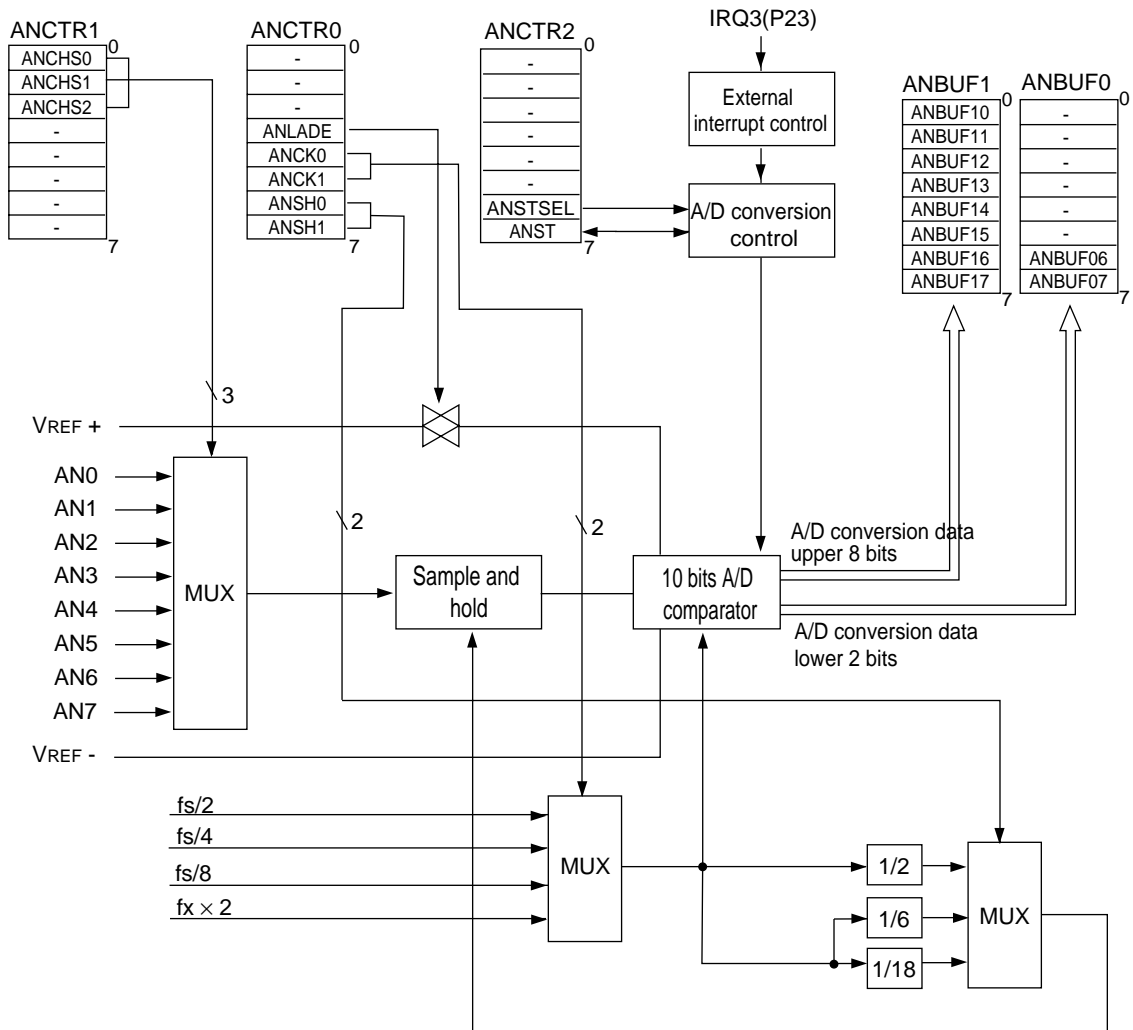


Figure 16-1-1 A/D Converter Block Diagram

## 16-2 Control Registers

A/D converter consists of the control register (ANCTRn) and the data storage buffer (ANBUFn).

### 16-2-1 Registers

Table 16-2-1 shows the registers used to control A/D converter.

**Table 16-2-1 A/D Converter Control Registers**

Register	Address	R/W	Function	Page
ANCTR0	x'03FB0'	R/W	A/D converter control register 0	XVI - 5
ANCTR1	x'03FB1'	R/W	A/D converter control register 1	XVI - 6
ANCTR2	x'03FB2'	R/W	A/D converter control register 2	XVI - 6
ANBUF0	x'03FB3'	R	A/D converter data storage buffer 0	XVI - 7
ANBUF1	x'03FB4'	R	A/D converter data storage buffer 1	XVI - 7
ADICR	x'03FFB'	R/W	A/D +converter interrupt control register	III - 38
IRQ3ICR	x'03FE5'	R/W	External interrupt 3 control register	III - 21
EDGDT	x'03F8F'	R/W	Both edges interrupt control register	III - 46
PAIMD	x'03F3A'	R/W	Port A input mode register	IV - 47
PAPLUD	x'03F4A'	R/W	Port A pull-up/pull-down resistance control register	IV - 47

R/W : Readable/Writable

R : Readable only



## 16-2-2 Control Registers

### ■ A/D Converter Control Register 0 (ANCTR0)

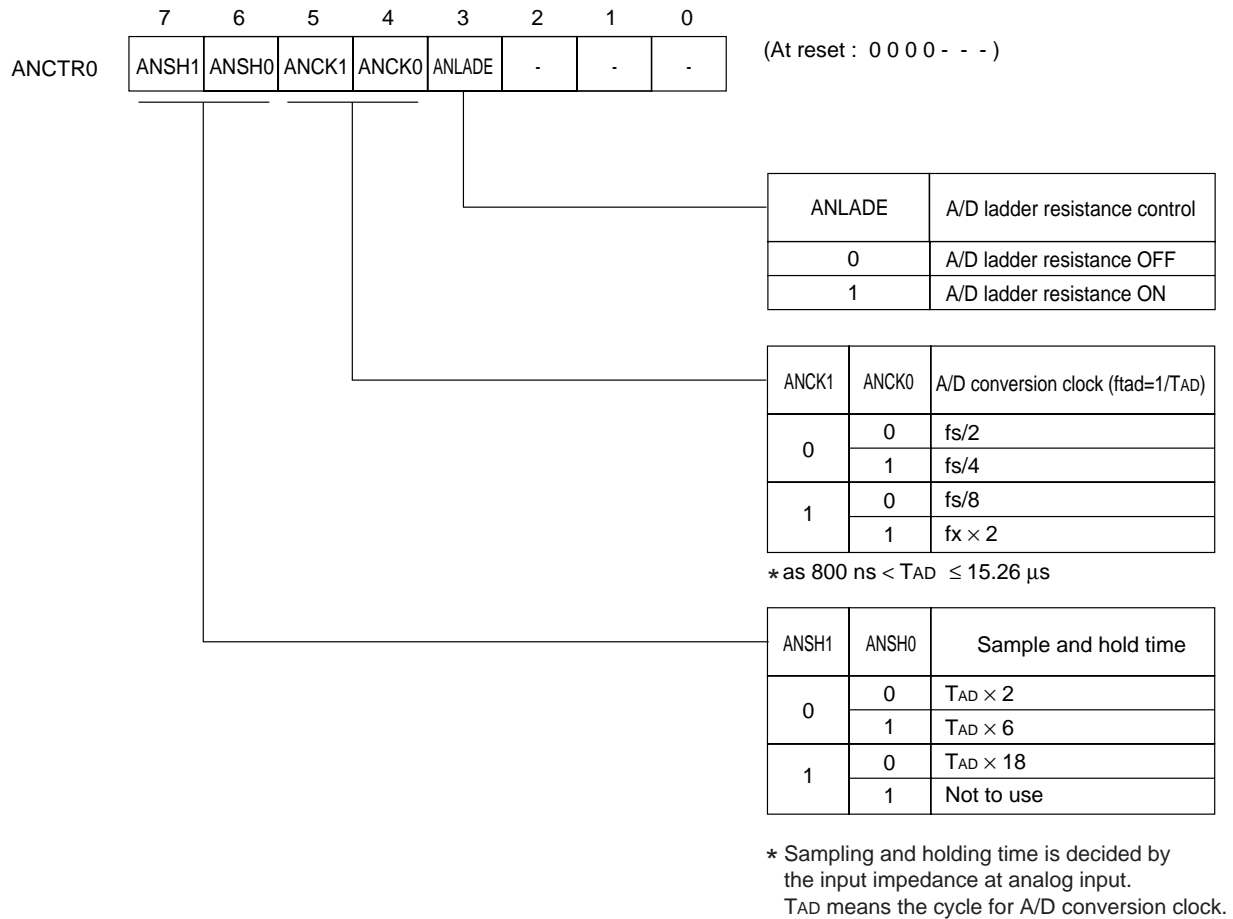


Figure 16-2-1 A/D Converter Control Register 0 (ANCTR0 : x'03FB0', R/W)

■ A/D Converter Control Register 1 (ANCTR1)

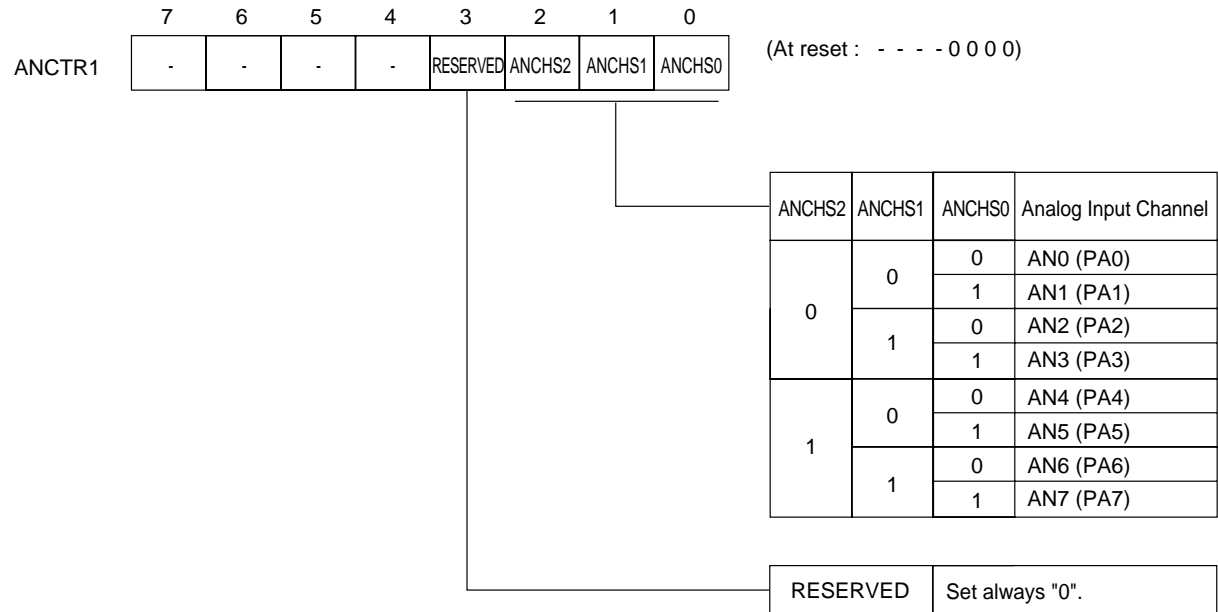


Figure 16-2-2 A/D Converter Control Register 1 (ANCTR1 : x'03FB1', R/W)

■ A/D Converter Control Register 2 (ANCTR2)

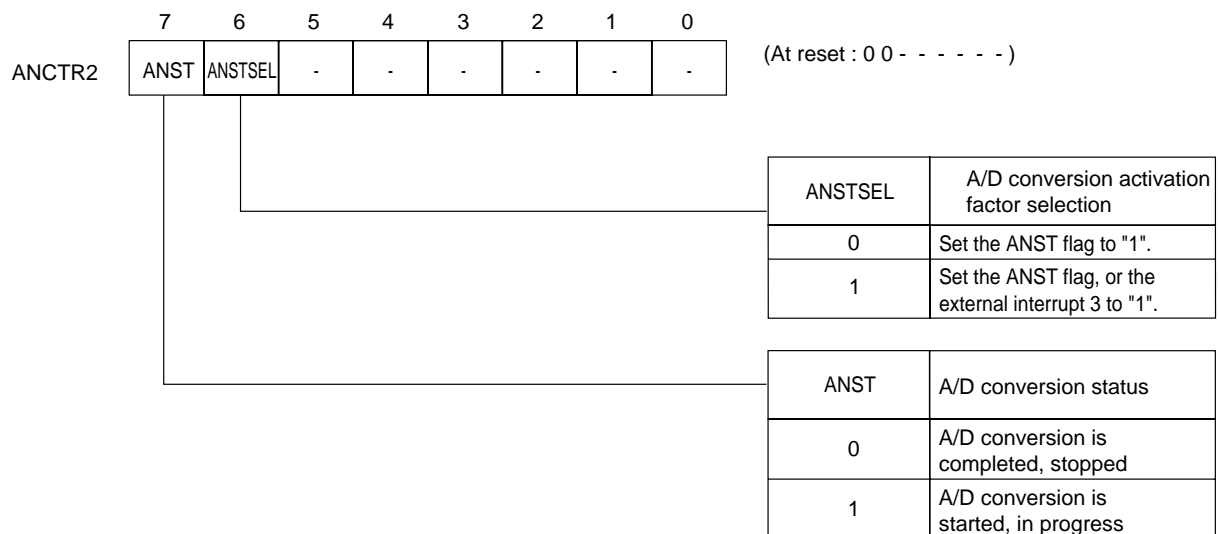
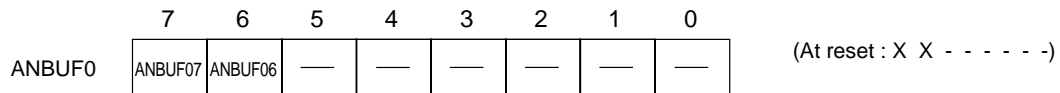


Figure 16-2-3 A/D Converter Control Register 2 (ANCTR2 : x'03FB2', R/W)

### 16-2-3 Data Buffers

#### ■A/D Conversion Data Storage Buffer 0 (ANBUF0)

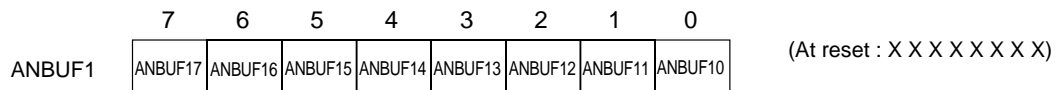
The lower 2 bits from the result of A/D conversion are stored to this register.



**Figure 16-2-4 A/D Conversion Data Buffer 0 (ANBUF0 : x'03FB3', R)**

#### ■A/D Conversion Data Storage Buffer 1 (ANBUF1)

The upper 8 bits from the result of A/D conversion are stored to this register.

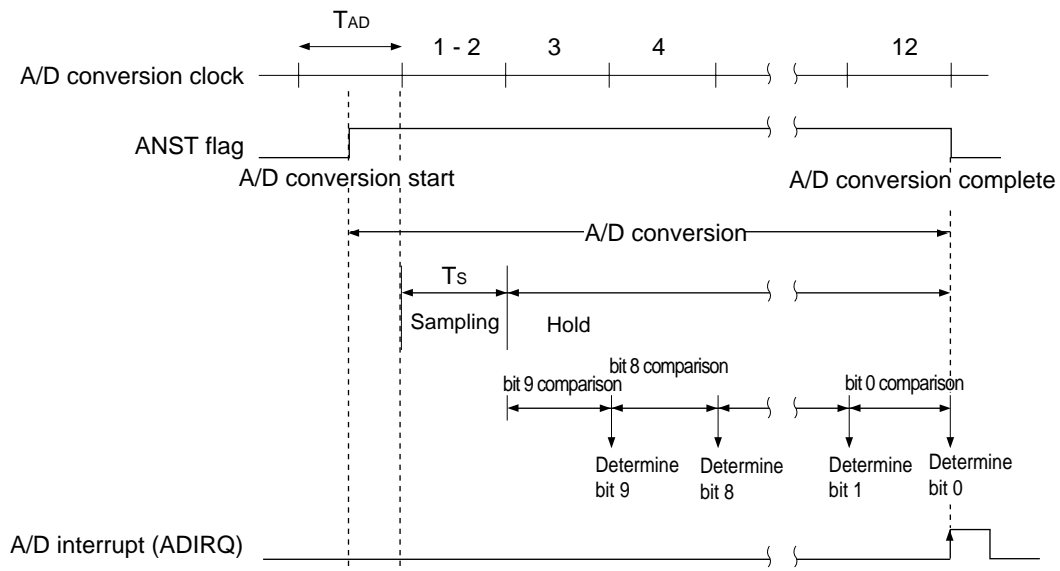


**Figure 16-2-5 A/D Conversion Data Buffer 1 (ANBUF1 : x'03FB4', R)**

## 16-3 Operation

Here is a description of A/D converter circuit setup procedure.

- (1) Set the analog pins.  
Set the analog input pin, set in (2), to "special function pin" by the port A input mode register (PAIMD).  
\* Setup for the port A input mode register should be done before analog voltage is put to pins.
- (2) Select the analog input pin.  
Select the analog input pin from AN7 to AN0 (PA7 to PA0) by the ANCHS2 to ANCHS0 flag of the A/D converter control register 1 (ANCTR1).
- (3) Select the A/D converter clock.  
Select the A/D converter clock by the ANCK1, ANCK0 flag of the A/D converter control register 0 (ANCTR0).  
Setup should be such a way that converter clock (TAD) does not drop less than 800 ns with any resonator.
- (4) Set the sample hold time.  
Set the sample hold time by the ANSH1, ANSH0 flag of the A/D converter control register 0 (ANCTR0). The sample hold time should be based on analog input impedance.
- (5) Set the A/D ladder resistance.  
Set the ANLADE flag of the A/D converter control register 0 (ANCTR0) to "1", and a current flow through the ladder resistance and A/D converter goes into the waiting.  
\* (2) to (5) are not in order. (3), (4) and (5) can be operated simultaneously.
- (6) Select the A/D converter activation factor, then start A/D conversion.  
Set the ANST flag of the A/D converter control register 2 (ANCTR2) to "1" to start A/D converter, or set the ANSTSEL flag of the A/D converter control register 2 (ANCTR2) to "1" to start A/D conversion by the external interrupt IRQ3.  
\* Specify the valid edge by the EDGSEL3 flag of the both edges interrupt control register (EDGDT) and the REDG3 flag of the external interrupt 3 control register (IRQ3ICR).
- (7) A/D conversion  
Each bit of the A/D buffer 0,1 is generated after sampling with the sample and hold time set in (3). Each bit is generated in sequence from MSB to LSB.
- (8) Complete the A/D conversion.  
When A/D conversion is finished, the ANST flag is cleared to "0", and the result of the conversion is stored to the A/D buffer (ANBUF0, 1). At the same time, the A/D complete interrupt request (ADIRQ) is generated.



**Figure 16-3-1 Operation of A/D Conversion**



To read the value of the A/D conversion, A/D conversion should be done several times to prevent noise error by confirming the match of level by program, or by using the average value.

## 16-3-1 Setup

### ■Input Pins of A/D Converter Setup

Input pins for A/D converter is selected by the ANCH2 to 0 flag of the ANCTR1 register.

**Table 16-3-1 Input Pins of A/D Converter Setup**

ANCHS2	ANCHS1	ANCHS0	A/D pin
0	0	0	AN0 pin
		1	AN1 pin
	1	0	AN2 pin
		1	AN3 pin
1	0	0	AN4 pin
		1	AN5 pin
	1	0	AN6 pin
		1	AN7 pin

### ■Clock of A/D Converter Setup

The A/D converter clock is set by the ANCK1 to 0 flag of the ANCTR0 register. Set the A/D converter clock (TAD) more than 800 ns and less than 15.26  $\mu$ s. Table 16-3-2 shows the machine clock (fosc, fx, fs) and the A/D converter clock (TAD). (calculated as  $f_s = f_{osc}/2$ ,  $f_x/4$ )

**Table 16-3-2 A/D Conversion Clock and A/D Conversion Cycle**

ANCK1	ANCK0	A/D conversion clock	A/D conversion cycle (TAD)		
			at oscillation for high speed		at oscillation for low speed
			at fosc=20 MHz	at fosc=8.38 MHz	at fx=32.768 kHz
0	0	fs/2	200.00 ns (no usable)	477.33 ns (no usable)	244.14 $\mu$ s (no usable)
	1	fs/4	400.00ns (no usable)	954.65ns	488.28 $\mu$ s (no usable)
1	0	fs/8	800.00 ns	1.91 $\mu$ s	976.56 $\mu$ s (no usable)
	1	fx x 2	15.26 $\mu$ s	15.26 $\mu$ s	15.26 $\mu$ s

For the system clock (fs), refer to Chapter 2. 2-5 Clock Switching.

### ■Sampling Time (Ts) of A/D Converter Setup

The sampling time of A/D converter is set by the ANSH1 to 0 flag of the ANCTR0 register. The sampling time of A/D converter depends on external circuit, so set the right value by analog input impedance.

**Table 16-3-3 Sampling Time of A/D Conversion and A/D Conversion Time**

ANSH1	ANSH0	Sampling time (Ts)	A/D conversion time			
			at TAD=800 ns	at TAD=954.65 ns	at TAD=1.91 $\mu$ s	at TAD=15.26 $\mu$ s
0	0	TAD x 2	9.60 $\mu$ s	11.46 $\mu$ s	22.92 $\mu$ s	183.12 $\mu$ s
	1	TAD x 6	12.80 $\mu$ s	15.27 $\mu$ s	30.56 $\mu$ s	244.16 $\mu$ s
1	0	TAD x 18	22.40 $\mu$ s	26.73 $\mu$ s	53.48 $\mu$ s	427.28 $\mu$ s
	1	Reserved	-	-	-	-

### ■ Built-in Ladder Resistor Control

The ANLADE flag of the ANCTR0 register is set to "1" to send a current to the ladder resistance for A/D conversion. As A/D converter is stopped, the ANLADE flag of the ANCTR0 register is set to "0" to save the power consumption.

**Table 16-3-4 A/D Ladder Resistor Control**

ANLADE	A/D ladder resistance control
0	A/D ladder resistance OFF (A/D conversion stopped)
1	A/D ladder resistance ON (A/D conversion operated)

### ■ A/D Conversion Activation Factor Selection Setup


The A/D conversion activation factor is set by the ANSTSEL flag of the ANCTR2 register. The ANSTSEL flag of the ANCTR2 register is set to "1" to start A/D conversion by the external interrupt 3. And if the ANST flag of the ANCTR2 register is set to "1", A/D conversion can be started.

**Table 16-3-5 A/D Conversion Activation Factor Selection**

ANSTSEL	A/D conversion activation factor
1	The external interrupt 3, or set "1" to the ANST flag
0	Set the ANST flag to "1".



If the external interrupt 3 is selected as the A/D conversion activation factor, specify the valid edge by the REDG3 flag of the external interrupt 3 control register (IRQ3ICR), and the EDGSEL3 flag of the both edges interrupt control register (EDGDT).

[  Chapter 3. 3-3 External Interrupts ]



Specify the interrupt valid edge before the external interrupt 3 is selected as the A/D conversion activation factor.

### ■ A/D Conversion Starting Setup

A/D conversion starting is set by the ANST flag of the ANCTR2 register. The ANST flag of the ANCTR2 register is set to "1" to start A/D conversion. When the external interrupt 3 is selected as the A/D conversion activation factor, the ANST flag of the ANCTR2 register is set to "1" to start A/D conversion, as the external interrupt 3 is generated. Also, the ANST flag of the ANCTR2 register is set to "1" during A/D conversion, then cleared to "0" as the A/D conversion complete interrupt is generated.

**Table 16-3-6 A/D Conversion Starting**


ANST	A/D conversion status
1	A/D conversion started or in progress.
0	A/D conversion completed or stopped

## 16-3-2 Setup Example

### ■A/D Converter Setup Example by Registers

A/D conversion is started by setting registers. The analog input pins are set to AN0, the converter clock is set to  $f_s/4$ , and the sampling hold time is set to  $TAD \times 6$ . Then, A/D conversion complete interrupt is generated.

An example setup procedure, with a description of each step is shown below.

Setup Procedure	Description
(1) Set the analog input pin. PAIMD (x'3F3A') bp0 : PAIMD0 = 1 PAPLUD (x'3F4A') bp0 : PAPLUD0 = 0	(1) Set the analog input pin, set in (2), to the special function pin by the port A input mode register (PAIMD). Also, set no pull-up/pull-down resistance by the port A pull-up/pull-down resistance control register (PAPLUD).
(2) Select the analog input pin. ANCTR1 (x'3FB1') bp2-0 : ANCHS2-0 = 000	(2) Select the analog input pin from AN7-0 (PA7-0) by the ANCHS2-0 flag of the A/D converter control register 1 (ANCTR1).
(3) Select the A/D converter clock. ANCTR0 (x'3FB0') bp5-4 : ANCK1-0 = 01	(3) Select the A/D converter clock by the ANCK1, ANCK0 flag of the A/D converter control register 0 (ANCTR0).
(4) Set the sample and hold time. ANCTR0 (x'3FB0') bp7-6 : ANSH1-0 = 01	(4) Set the sample and hold time by the ANSH1, ANSH0 flag of the A/D converter control register 0 (ANCTR0).
(5) Set the interrupt level. ADICR (x'3FFA') bp7-6 : ADLV1-0 = 00	(5) Set the interrupt level by the ADLV1-0 flag of the A/D conversion complete interrupt control register (ADICR). If any interrupt request flag is already set, clear them. [  Chapter 3. 3-1-4 Interrupt Flag Setting ]
(6) Enable the interrupt. ADICR (x'3FFA') bp1 : ADIE = 1	(6) Enable the interrupt by setting the ADIE flag the ADICR register to "1".
(7) Set the A/D ladder resistance. ANCTR0 (x'3FB0') bp3 : ANLADE = 1	(7) Set the ANLADE flag of the A/D converter control register 0 (ANCTR0) to "1" to send a current to the ladder resistance for the A/D conversion.



Setup Procedure	Description
(8) Start the A/D conversion. ANCTR2 (x'3FB2') bp6 : ANSTSEL = 0	(8) Set the ANSTSEL flag of the A/D converter control register 2 (ANCTR2) to "0", and select "writing to the ANST flag of the A/D converter control register 2 (ANCTR2)" as the A/D converter activation factor.
(9) Start the A/D conversion operation. ANCTR2 (x'3FB2') bp7 : ANST = 1	(9) Set the ANST flag of the A/D converter control register 2 (ANCTR2) to "1" to start the A/D conversion.
(10) Complete the A/D conversion. ANBUF0 (x'3FB3') ANBUF1 (x'3FB4')	(10) When the A/D conversion is finished, the A/D conversion complete interrupt is generated and the ANST flag of the A/D converter control register 2 (ANCTR2) is cleared to "0". The result of the conversion is stored to the A/D converter buffer (ANBUF0, 1).

Note : The above (3) to (4) can be set at once.




Start the A/D conversion after the current flowing through the ladder resistors stabilizes. The wait time should be decided by the calculated times from the ladder resistance (max. 80 kΩ), and the external bypass capacitor connected between VREF+ and VREF-.

### ■ A/D Conversion Setup Example by External Interrupt 3

The A/D conversion is started by the external interrupt 3. The analog input pin is set to AN0, the converter clock is set to  $f_s/4$ , and the sample hold time is set to  $TAD \times 6$ . Then, the A/D conversion complete interrupt is generated.

An example setup procedure, with a description of each step is shown below.

Setup Procedure	Description
(1) Set the analog input pin. PAIMD (x'3F3A') bp0 : PAIMD0 = 1 PAPLUD (x'3F4A') bp0 : PAPLUD0 = 0	(1) Set the analog input pin that set in (2), to the special function pin by the port A input mode register (PAIMD). Also, set no pull-up/pull-down resistance by the port A pull-up/pull-down resistance control register (PAPLUD).
(2) Select the analog input pin. ANCTR1 (x'3FB1') bp2-0 : ANCH2-0 = 000	(2) Select the analog input pin from AN7-0 (PA7-0) by the ANCHS2-0 flag of the A/D converter control register 1 (ANCTR1).
(3) Select the A/D converter clock. ANCTR0 (x'3FB0') bp5-4 : ANCK1-0 = 01	(3) Select the A/D converter clock by the ANCK1, ANCK0 flag of the A/D converter control register 0 (ANCTR0).
(4) Set the sample hold time. ANCTR0 (x'3FB0') bp7-6 : ANSH1-0 = 01	(4) Set the sample hold time by the ANSH1, ANSH0 flag of the A/D converter control register 0 (ANCTR0).
(5) Specify the external interrupt 3 valid edge. IRQ3ICR (x'3FE5') bp5 : REDG3 = 1 EDGDT (x'3F8F') bp3 : EDGSEL3 = 0	(5) Specify the valid edge by the REDG3 flag of the external interrupt 3 control register (IRQ3ICR), the EDGSEL3 flag of the both edges interrupt control register (EDGDT).
(6) Set the interrupt level. ADICR (x'3FFA') bp7-6 : ADLV1-0 = 10	(6) Set the interrupt level by the ADLV1-0 flag of the A/D conversion complete interrupt control register (ADICR). If any interrupt request flag is already set, clear them. [  Chapter 3. 3-1-4 Interrupt Flag Setup ]
(7) Enable the interrupt. ADICR (x'3FFA') bp1 : ADIE = 1	(7) Enable the interrupt by setting the ADIE flag of the ADICR register to "1".

Setup Procedure	Description
(8) Set the A/D ladder resistance. ANCTR0 (x'3FB0') bp3 : ANLADE = 1	(8) Set the ANLADE flag of the A/D converter control register 0 (ANCTR0) to "1" to send a current to the ladder resistance for the A/D conversion.
(9) Select the A/D converter activation factor. ANCTR2 (x'3FB2') bp6 : ANSTSEL = 1	(9) Set the ANSTSEL flag of the A/D converter control register 2 (ANCTR2) to "1", and select "writing to the ANST flag of the A/D converter control register 3 (ANCTR3), the external interrupt 3" as the A/D converter activation factor.
(10) Start the A/D conversion. ANCTR2 (x'3FB2') bp7 : ANST = 1	(10) When the external interrupt 3, set in (5) is generated, the ANST flag of the A/D converter control register 2 (ANCTR2) is set to "1" to start the A/D conversion. And even if the external interrupt 3 is not generated, the A/D conversion is started by setting the ANST flag of the A/D converter control register 3 (ANCTR3) to "1".
(11) Complete the A/D conversion.	(11) When the A/D conversion is finished, the A/D conversion complete interrupt is generated, and the ANST flag of the A/D converter control register 2 (ANCTR2) is cleared to "0". The result of the conversion is stored to the A/D converter buffer (ANBUF0, 1).

Note : The above (3) to (4) can be set at once.

Even if the external interrupt 3 is generated during A/D conversion, the A/D converter is operated in normal.

Also, once the A/D conversion is finished, it is never started again.

### 16-3-3 Cautions

A/D conversion can be damaged by noise easily, hence anti-noise transaction should be operated.

■Anti-noise transaction

For A/D input (analog input pin), add condenser near the Vss pins of micro controller.

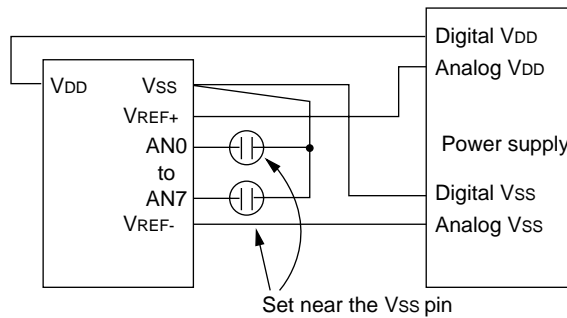


Figure 16-3-2 A/D Converter Recommended Example 1

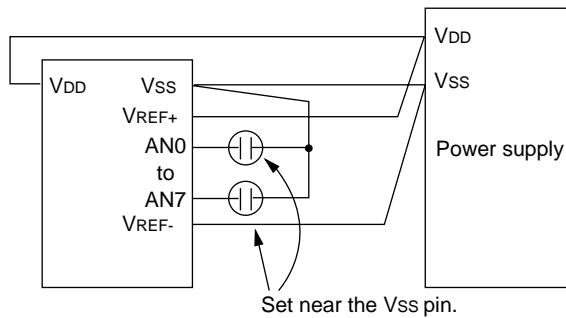
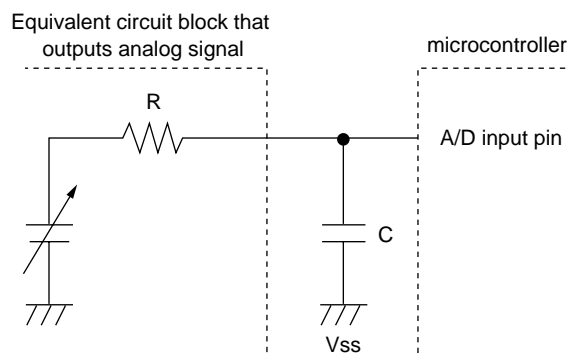


Figure 16-3-3 A/D Converter Recommended Example 2



To maintain high precision of A/D conversion, following instructions on use of A/D converter should be strictly kept.

1. Input impedance  $R$  of A/D input pin should be under  $500\text{ k}\Omega^{*1}$ . And connect the external capacitor  $C$  (over  $1000\text{ pF}$ , under  $1\text{ }\mu\text{F}$ )<sup>\*1</sup> between  $V_{SS}$  and the A/D input pin.
2. Set the A/D conversion frequency depending on the time constant of  $R$  and  $C$ .
3. Changing the output level of the microcontroller or switching ON/OFF of the peripheral added circuit while the A/D conversion is in progress may lower the precision of A/D conversion, for these may fluctuate the values of the analog input pin and the power pin. Check the waveform of the analog input pin before the system evaluation.



$$1\text{ }\mu\text{F} \geq C \geq 1000\text{ pF} \text{ *1}$$

$$\text{as } R \leq 500\text{ k}\Omega$$

\*1 : That value is for reference.

### Recommended Connection with A/D Converter





## 17-1 Overview

This LSI has a built-in D/A converter with 8 bits solution. There are 4 output channels and 8-bit data registers for each channel. In D/A conversion mode, there are 3 modes : channel fixed conversion mode, 2 channels conversion mode and 4 channels conversion mode. At 2 and 4 channels conversion mode, the time for switching channels can be programmed by the software. When the D/A converter is not used, the built-in ladder resistance can be set to OFF to save the power consumption.

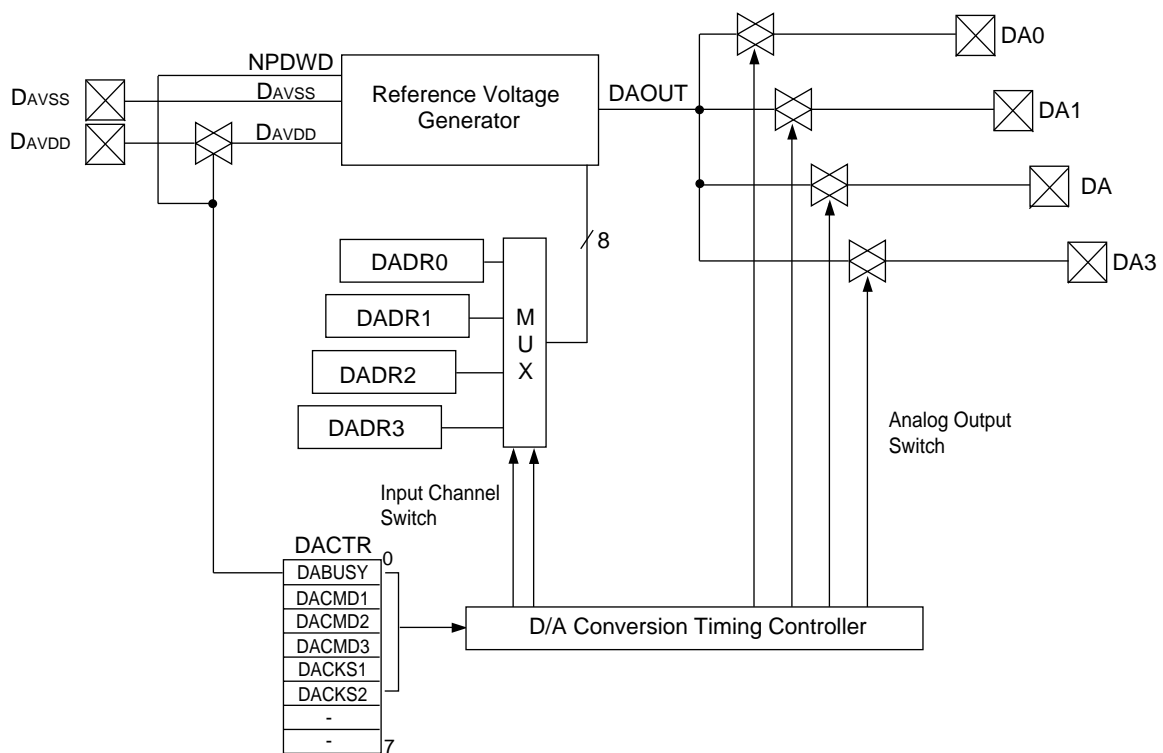


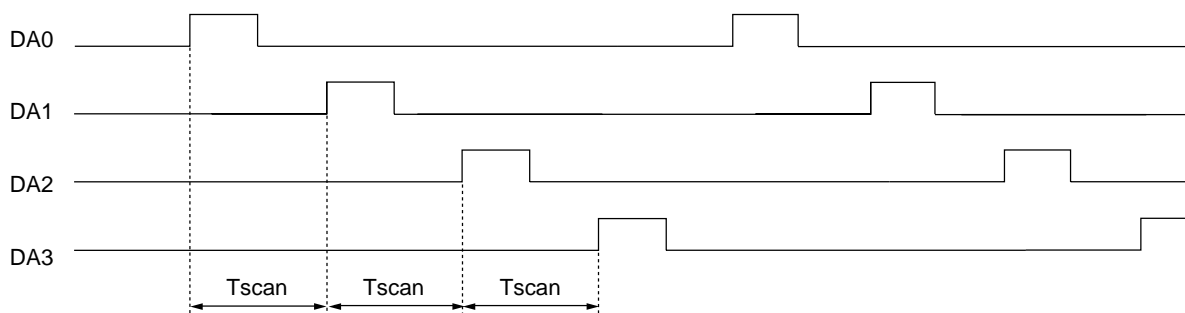
Figure 17-1-1 D/A Converter Block Diagram



## 17-2 D/A Conversion

Here is the setup procedure for D/A converter circuit operation.

- (1) Select the D/A conversion mode by the DACMD3 to DACMD1 flag of the D/A control register (DACTR).
- (2) Set the switching time of analog output channel by the DACKS2 to DACKS1 flag of the DACTR register. When the fixed conversion mode is selected in (1), this setup is not valid.
- (3) Set the DABUSY flag of the DACTR register to "1" to send the ladder resistance current to start the D/A conversion.
- (4) The D/A conversion is done to the data that is set to the DADR3 to the DADR0 register, and its result output to the DA0 to DA3 in accordance with the setup in (1), (2). If the scan conversion is selected, the pins are high impedance while the D/A output is not done.



Tscan : The time that set by the DACKS2, DACKS1.

The half of Tscan is high impedance to prevent an imperfect output.

**Figure 17-2-1 4 Channel Scan Conversion Mode Timing**



At D/A conversion, preset the PSCEN flag of the prescaler control register (PSCMD), regardless of the conversion mode, to enable the prescaler counting.

[  Chapter 5. Prescaler ]

## 17-3 D/A Converter Control Registers

### 17-3-1 Overview

Table 17-3-1 shows the registers to control the D/A converter in MN101C49K.

**Table 17-3-1 D/A Converter Control Registers**

Register	Address	R/W	Function	Page
DACTR	x'03FBB'	R/W	D/A converter control register	XVII - 5
DADR0	x'03FBC'	R/W	D/A converter input data register 0	XVII - 6
DADR1	x'03FBD'	R/W	D/A converter input data register 1	XVII - 6
DADR2	x'03FBE'	R/W	D/A converter input data register 2	XVII - 6
DADR3	x'03FBF'	R/W	D/A converter input data register 3	XVII - 6
PCDIR	x'03F3C'	R/W	Port C direction control register	IV - 50
PCPLU	x'03F4C'	R/W	Port C pull-up resistance control register	IV - 50

R/W : Readable/Writable

### 17-3-2 D/A Converter Control Register (DACTR)

This is the 8-bit readable/writable register that controls the D/A conversion.

■D/A Converter Control Register (DACTR)

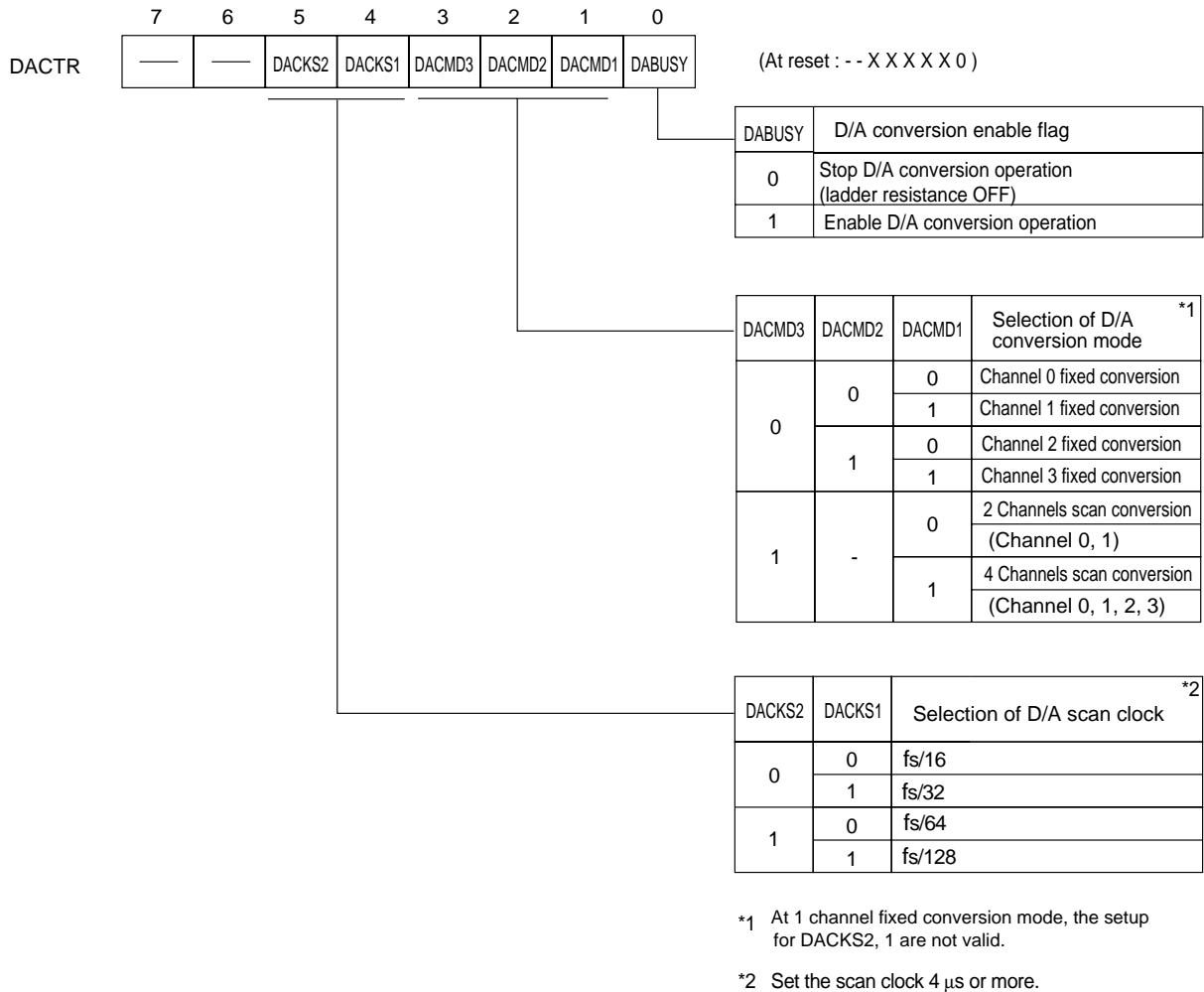


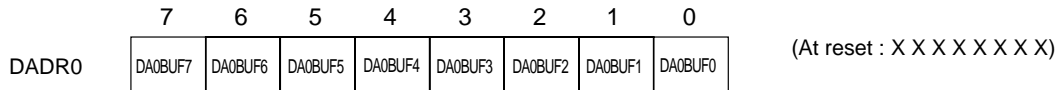
Figure 17-3-1 D/A Converter Control Register (DACTR : x'03FBB' R/W)

### 17-3-3 D/A Converter Input Data Registers

These readable/writable registers store the A/D converter data.

■D/A Converter Input Data Register 0 (DADR0)

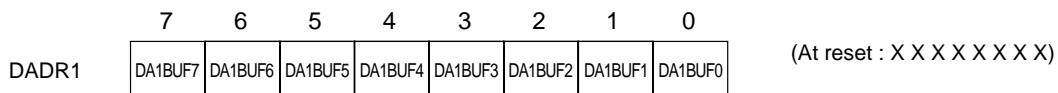
This register stores the D/A conversion data (for DA0 channel).



**Figure 17-3-2 D/A Converter Input Data Register 0 (DADR0 : x'03FBC' R/W)**

■D/A Converter Input Data Register 1 (DADR1)

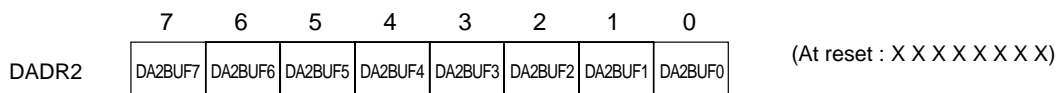
This register stores the D/A conversion data (for DA1 channel).



**Figure 17-3-3 D/A Converter Input Data Register 1 (DADR1 : x'03FBD' R/W)**

■D/A Converter Input Data Register 2 (DADR2)

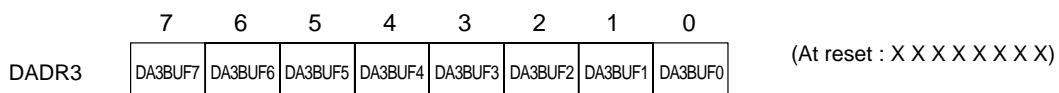
This register stores the D/A conversion data (for DA channel).



**Figure 17-3-4 D/A Converter Input Data Register 2 (DADR2 : x'03FBE' R/W)**

■D/A Converter Input Data Register 3 (DADR3)

This register stores the D/A conversion data (for DA3 channel).



**Figure 17-3-5 D/A Converter Input Data Register 3 (DADR3 : x'03FBF' R/W)**

## 17-4 D/A Converter Setup Example

### ■4 Channel Scan Clock D/A Converter Setup Example

Set the D/A conversion mode to 4 channel scan clock converter, and set the scan clock to fs/16.

An example setup procedure, with a description of each step is shown below.

Setup Procedure	Description
(1) Select the prescaler operation. PSCMD (x'3F6F') bp0 : PSCEN = 1	(1) Set the PSCEN flag of the PSCMD register to "1" to select prescaler operation.
(2) Set the port C pin. PCDIR (x'3F3C') bp3-0 : PCDIR3-0 = 0000 PCPLU (x'3F4C') bp3-0 : PCPLU3-0 = 0000	(2) Set the analog output pin, set in (3), to "input mode" by the port C I/O direction control register (PCDIR), and to "no pull-up resistance" by the port C pull-up resistance control register (PCPLU).
(3) Set the D/A conversion mode. DACTR (x'3FBB') bp3-1 : DACMD3-1 = 111	(3) Set the analog output channel to "4 channels scan converter" by the DACMD3-1 flag of the D/A converter control register (DACTR).
(4) Select the scan clock. DACTR (x'3FBB') bp5-4 : DACKS2-1 = 00	(4) Set the scan clock to "fs/16" by the DACKS2-1 flag of the D/A converter control register (DACTR).
(5) Set the D/A converter input data. DADR0 (x'3FBC') DADR1 (x'3FBD') DADR2 (x'3FBE') DADR3 (x'3FBF')	(5) Set the D/A conversion data by the D/A converter input register 3-0 (DADR3-0).
(6) Start the D/A conversion. DACTR (x'3FBB') bp0 : DABUSY = 1	(6) Set the DABUSY flag of the D/A converter control register (DACTR) to "1" to start the D/A conversion. Its result outputs to the DA3-DA0 pins in accordance with the setup in (4).

Note : The above (2) to (3) can be set at once.





# 18-1 Overview

In the memory expansion mode, or the processor mode, the AC timing of the control signal to the external connected device can be changed by the software. This function can set independently each of the AC timing of the data strobe signal (p51/NRE) at reading and the data strobe signal (p50/NWE) at writing. The setup time and the hold time are set to the AC timing control register (ACTMD) by the software.

## ■AC Timing Control Register (ACTMD)

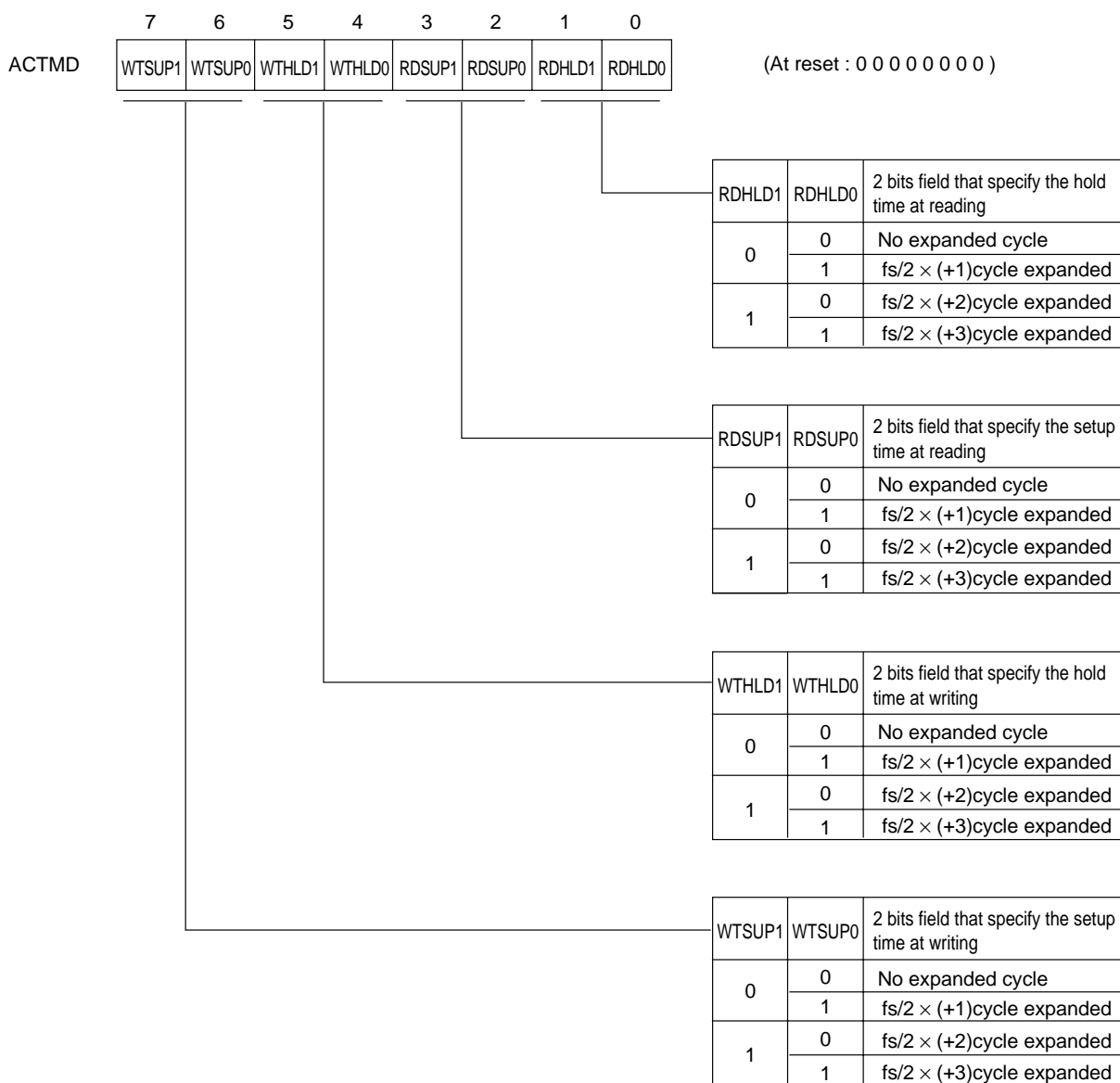


Figure 18-1-1 AC Timing Control Register (ACTMD : x'03F06', R/W)



## 18-2 Operation

### 18-2-1 Setup

#### ■AC Timing Setup

AC timing variable function can set independently each of the timing of the data strobe signal (p51/NRE) at reading, and the data strobe signal (p50/NWE) at writing. The setup time and the hold time are set to the AC timing control register (ACTMD) by the software.

The AC timing control register (ACTMD) has 4 fields that set the setup time and the hold time at reading (the cycle for reading data from the external device) and, at writing (the cycle for writing data to the external device).

WTSUP : 2 bits field that specify the setup time at writing.

WTHLD : 2 bits field that specify the hold time at writing.

RDSUP : 2 bits field that specify the setup time at reading.

RDHLD : 2 bits field that specify the hold time at reading.

On each field, the expanded cycle count is specified with 1 unit : a half cycle of system clock (fs). "The set value of field" and "the expanded cycle count" are shown on figure 18-1-1.

#### ■Caution 1 on AC Timing Variable Function

When AC timing variable function is used, the external wait count that set by the memory control register (MEMCTR) should be set more than "the setup time + the hold time", both at reading and at writing. If the external wait count is set less than "the setup time + the hold time", the setup time and the hold time that set by the ACTMD register, are not valid, anymore.



Set the external wait count of the memory control register (MEMCTR) more than "the setup time + the hold time".

The external wait count  $\geq$  WTSUP + WTHLD

The external wait count  $\geq$  RDSUP + RDHLD

#### ■Caution 2 on AC Timing Variable Function

When the memory control register (MEMCTR) specified the hand shake mode, AC timing variable function can not be operated. At hand shake mode, even if the setup time and the hold time are set, AC timing variable function is not valid and the operation is at normal hand shake mode. Use it at the fixed wait mode.



At hand shake mode, AC timing variable function cannot be used.  
Select the fixed wait mode.

■Caution 3 on AC Timing Variable Function

The hold time at reading, set by RDHLD, is valid only for the output waveform of the data strobe signal to the external device. That is not used for the timing of storing data inside of micro controller. In micro controller, the reading data is latched at the same timing as the hold time is set to "0", regardless of the ACTMD register setup.

RDHLD should be "x'00", and the hold time at reading should not be set, except when the special signal control is needed at the external device. And when the special signal control should be operated with the RDHLD setup, the operation inside of the above micro controller should be considered for the system design.



The hold time (RDHLD) is not needed to be set, always set to "x'00", unless when the special signal control is done.

## 18-2-2 Operation

### ■AC Timing Features of Data Strobe Signal

AC timing of data strobe signal that sets the setup time and the hold time to the external device with AC timing variable function, is shown as follows.

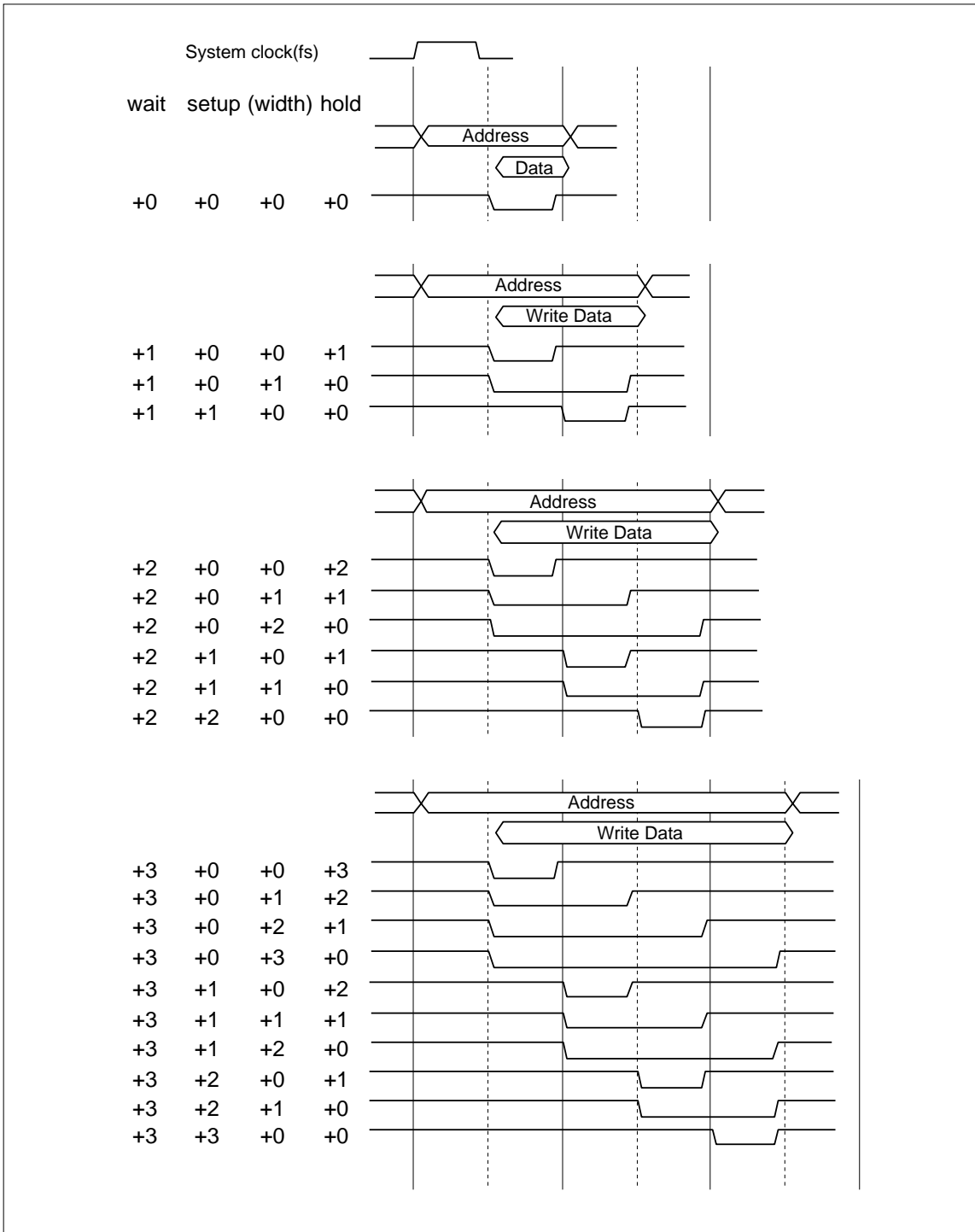



Figure 18-2-1 AC Timing Features of Data Strobe Signal

In figure 18-2-1, those values are the expanded counts as 1 unit is a half cycle of system clock (fs). "Wait" means the external wait count that specifies by the memory control register (MEMCTR), "setup" means the setup time at reading or writing, "hold" means the expanded cycle of the hold time.

### 18-2-3 Setup Example

An example setup procedure, with a description of each step is shown below.

Setup Procedure	Description
<p>(1) Set the external wait count. MEMCTR (x'3F01')</p> <p>bp3 : EXWH = 1 bp1-0 : EXW1-0 = wait count</p>	<p>(1) Set the wait count by the EXW1-0 flag of the MEMCTR register. At this time, set the EXWH flag to "1", and select the fixed wait mode. [  Chapter 2. 2-3-2 Control Registers ]</p>
<p>(2) Set the ACTMD register.</p> <p>bp7-6 : WTSUP1-0 bp5-4 : WTHLD1-0 bp3-2 : RDSUP1-0 bp1-0 : RDHLD1-0 = x'00'</p>	<p>(2) Set the setup time and the hold time by the ACTMD register. Normally, set the hold time (RDHLD) at reading to x'00'. The set timing is valid from the next cycle after writing the setup value to the ACTMD register.</p>



## 19-1 EPROM Version

### 19-1-1 Overview

EPROM version is microcomputer which was replaced the mask ROM of the MN101C49K with an electronically programmable 224 KB.

The MN101CP49KAF is sealed in plastic. Once data is written to the internal PROM, it cannot be erased. The PX-AP101C49-FAC is sealed in a ceramic package with a window. Written data can be erased by exposing the physical chip to intense ultraviolet radiation. We offer a 100-pin flat package of plastic, and of ceramic.

Setting the EPROM version to EPROM mode, functions as a microcomputer are halted, and the internal EPROM can be programmed. For EPROM mode pin connection, refer to figure 19-1-2. Programming Adapter Connection.

The specification for writing to the internal EPROM are the same as for a general-purpose 2 M-bit EPROM ( $V_{PP}=12.5\text{ V}$ ,  $t_{pw}=0.2\text{ ms}$ ). Therefore, by using a dedicated programming adapter (supplied by Panasonic) which can convert the 100 pin of EPROM version to 32 pin, having the same configuration as a normal EPROM, a general-purpose EPROM writer can be used to perform read and write operations.

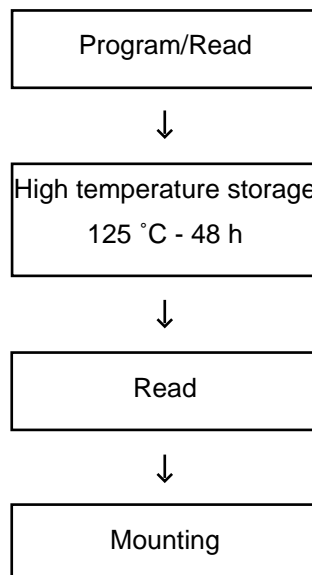
The EPROM Version is described on the following items :

- Cautions on use of the internal EPROM
- Erasing Data in Windowed Package (PX-AP101C49-FAC)
- Differences between mask ROM vers. and EPROM vers.
- Writing to the Microcomputer with internal EPROM
- Cautions on handling a ROM writer
- Programming adaptor connection

## 19-1-2 Cautions on Use

EPROM Version differs from the MN101C49K series mask ROM version in some of its electrical characteristics. The user should be aware of the following cautions :

- (1) To prevent data from being erased by ultraviolet light after a program is written, affix seals impermeable to UV rays to the glass sections at the top and side sections of the CPU.  
(PX-AP101C49-FAC)
- (2) Because of device characteristics of the MN101CP49KAF, a writing test cannot be performed on all bits. Therefore, the reliability of data writing may not be 100% ensured.
- (3) When a program is written, be sure that  $V_{DD}$  power supply (6 V) is connected before applying the  $V_{PP}$  power supply (12.5 V). Disconnect the  $V_{PP}$  supply before disconnecting the  $V_{DD}$  supply.
- (4)  $V_{PP}$  should never exceed 13.5 V including overshoot.
- (5) If a device is removed while a  $V_{PP}$  of +12.5 V is applied, device reliability may be damaged.
- (6) At  $NCE=V_{IL}$ , do not change  $V_{pp}$  from  $V_{IL}$  to +12.5 V or from +12.5 V to  $V_{IL}$ .
- (7) After a program is written, screening at a high temperature storage is recommended before mounting.



### **19-1-3 Erasing Data in Windowed Package (PX-AP101C49-FAC)**

To erase data of an internal EPROM with windowed packaging ("0" → "1"), UV light at 253.7 nm is used to irradiate the chip through a permeable cover.

The recommended exposure is 10 W·s/cm<sup>2</sup>. This coverage can be achieved by using a commercial UV lamp positioned 2 to 3 cm above the package for 15 - 20 minutes (when the illumination intensity of the package surface is 12000 μW/cm<sup>2</sup>). Remove any filters attached to the lamp. With a mirrored reflector plate to the lamp, illumination intensity will increase 1.4 to 1.8 times, and decrease the erasure time.

If the window becomes dirty with oil, adhesive, etc., UV light permeability will get worse, causing the erasure time to increase. If this happens, clean with alcohol or another solvent that will not harm the package. The above recommended exposure has enough leeway, with several times as much as it takes to erase all the bits. It is based on the reliable data over all temperature and voltage. The lamp and the level of illumination should be regularly checked and well controlled.

Data in internal EPROM with windowed packaging is erased by applying a light that the wavelength is shorter than 400 nm. Fluorescent lamp and sunlight are not able to erase data as much as UV light of 253.7 nm is, but those light sources are also able to erase data more or less. To expose those light sources for a long while can damage its system. To prevent this, cover the window with an opaque label.

If the wavelength is longer than 400 nm to 500 nm, data can not be erased. However, because of typical semiconductor characteristics, the circuit may malfunction if the chip is exposed to an extremely high illumination intensity. The chip will operate normally if this exposure is stopped. However, for areas where it is continuous, take necessary precautions against the light that the wavelength is longer than 400 nm.



## 19-1-4 Differences between Mask ROM version and EPROM version

The differences between the 8-bit microcomputer MN101C49G/49H/49K (Mask ROM vers.) and MN101CP49K (internal EPROM version) are as follows ;

**Table 19-1-1 Differences between Mask ROM version and internal EPROM version**

	MN101C49G/49H/49K (Mask ROM version)	MN101CP49K (EPROM version)
Operating ambient temperature	- 40 °C to 85 °C	- 20 °C to 70 °C
Operating voltage	2.0 V to 5.5 V (1.00 μs / at 2 MHz) 2.0 V to 5.5 V (62.5 μs / at 32 kHz)	2.7 V to 5.5 V (1.00 μs / at 2 MHz) 2.7 V to 5.5 V (62.5 μs / at 32 kHz)
Pin DC Characteristics	Output current, input current and input judge level are the same.	
Oscillation Characteristics	The combination of oscillator and each version should be estimated to match when EPROM version is changed to Mask ROM version for mass production.	
Noise Characteristics	EMC check should be done on each version when EPROM version is changed to Mask ROM version for mass production	

There are no other functional differences.

### 19-1-5 Writing to Microcomputer with Internal EPROM

The device type that set by each ROM writer should be selected the mode for writing 2 M-bit EPROM. Set the writing voltage to 12.5 V.

- Mounting the device in the programming adapter and the position of the No.1 pin.

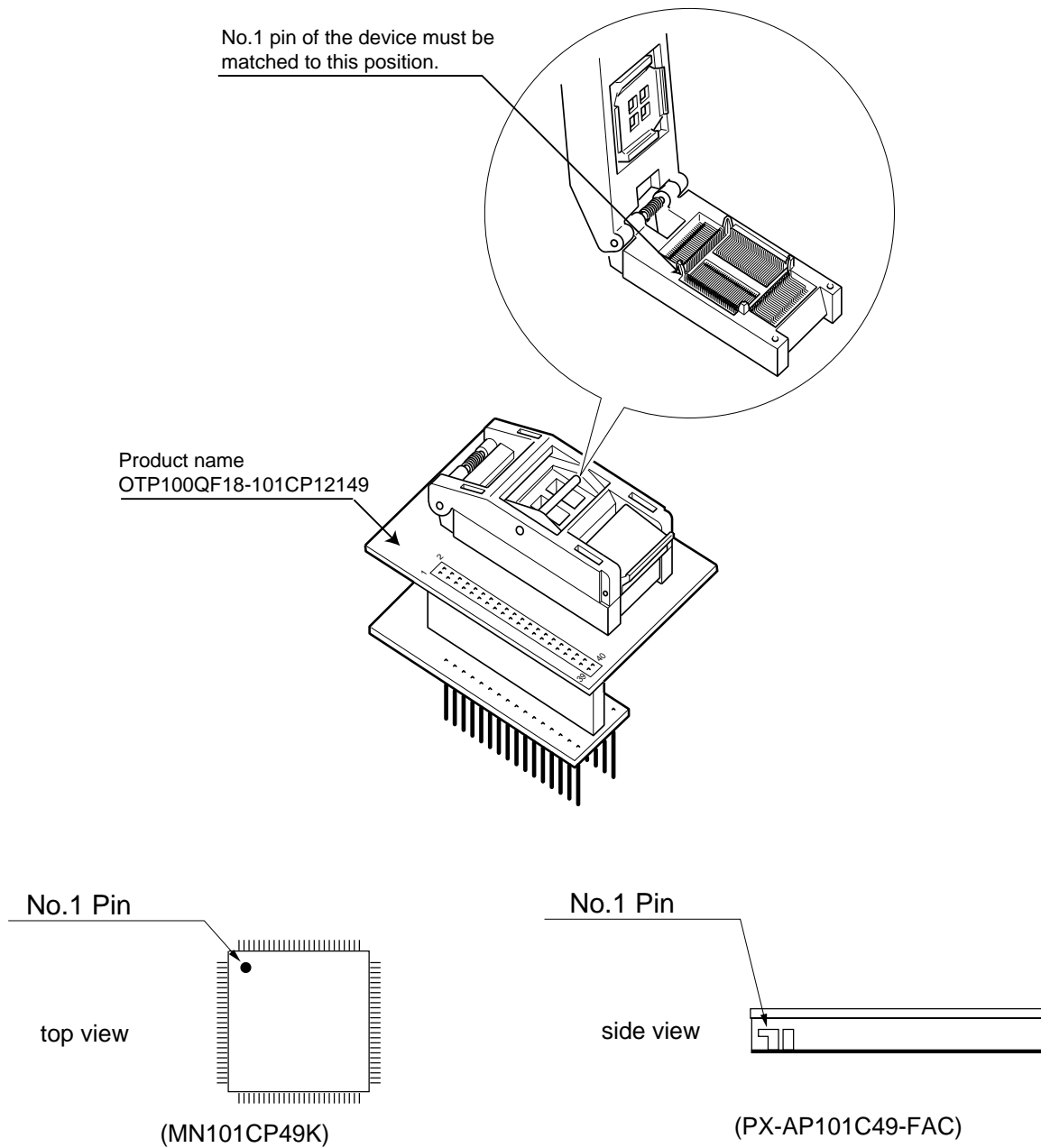


Figure 19-1-1 Mounting a Device in Programming Adapter and the Position of No.1 Pin

### ■ROM Writer Setup

The device types should be set up as listed below.

**Table 19-1-2 Setup for Device Type**

Equip. name	Vendor	Device type	Remarks
Pecker30	Aval Data	Mitsubishi 27C201	
LabSite	Data I/O	Mitsubishi 27C201	Do not run ID check and pin connection inspection.

The above table is based on the standard samples.


Please contact the nearest semiconductor design centre (Refer to the sales office table attached at the end of the manual), when you use the other equipment.

## 19-1-6 Cautions on Operation of ROM Writer

### ■Cautions on Handling the ROM writer

- (1) The  $V_{PP}$  programming voltage for the EPROM versions is 12.5 V.  
Programming with a 21 V ROM writer can lead to damage. The ROM writer specifications must match those for standard 2 M-bit EPROM :  $V_{PP}=12.5\text{ V}$  ;  $tpw=0.2\text{ ms}$ .
- (2) Make sure that the socket adapter matches the ROM writer socket and that the chip is correctly mounted in the socket adapter. Faulty connections can damage the chip.
- (3) After clearing all memory of the ROM writer, load the program to the ROM writer.
- (4) After confirming the device type, write the loaded program in (3) to this LSI address, from x'4000' to the final address of the internal ROM.



The internal ROM space of this LSI is from x'4000'.  
[  Chapter 2 2-2. Memory Space ]



This writer has no internal ID codes of "Silicon Signature" and "Intelligent Identifier" of the auto-device selection command of ROM writer. If the auto-device selection command is to be executed for this writer, the device is likely damaged. Therefore, never use this command.

### ■When the writing is disabled

When the writing is disabled, check the following points.

- (1) Check that the device is mounted correctly on the socket (pin bending, connection failure).
- (2) Check that the erase check result is no problem.
- (3) Check that the adapter type is identical to the device name.
- (4) Check that the writing mode is set correctly.
- (5) Check that the data is correctly transferred to the ROM writer.
- (6) Recheck the check points (1), (2) and (3) provided on the above paragraph of 'Cautions on Handling the ROM writer'.

### 19-1-7 Programming Adapter Connection

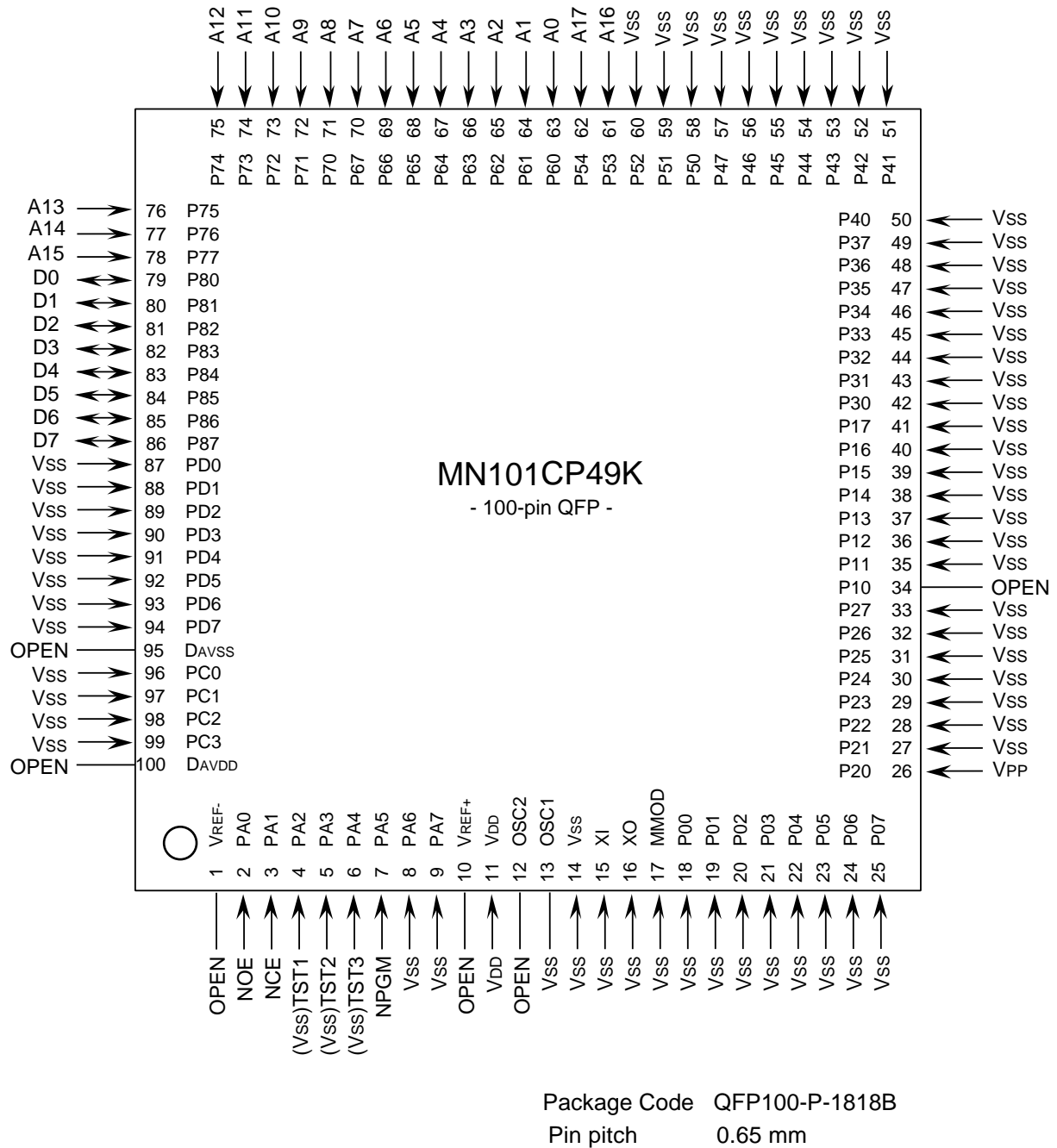



Figure 19-1-2 MN101CP49KAF EPROM Programming Adapter Connection

 Refer to the pin connection drawing of the 2M-bit EPROM (27C201).

## 19-2 Differences from the previous model

Differences from the previous model in oscillation characteristics of MN101C49K series.

### ■Power of OSC2 pin's output current

MN101C49K series (MN101C49G/49H/49K/CP49K/CF49K) has not so strong power of high speed oscillation pin's (OSC2 pins) output current to reduce EMI, compared with MN101C12G series (MN101C12G/CP12G). So, the combination of oscillator and each above version should be estimated to match.

The actual power of OSC2 pin's output current on standard sample is shown below. They are for reference.

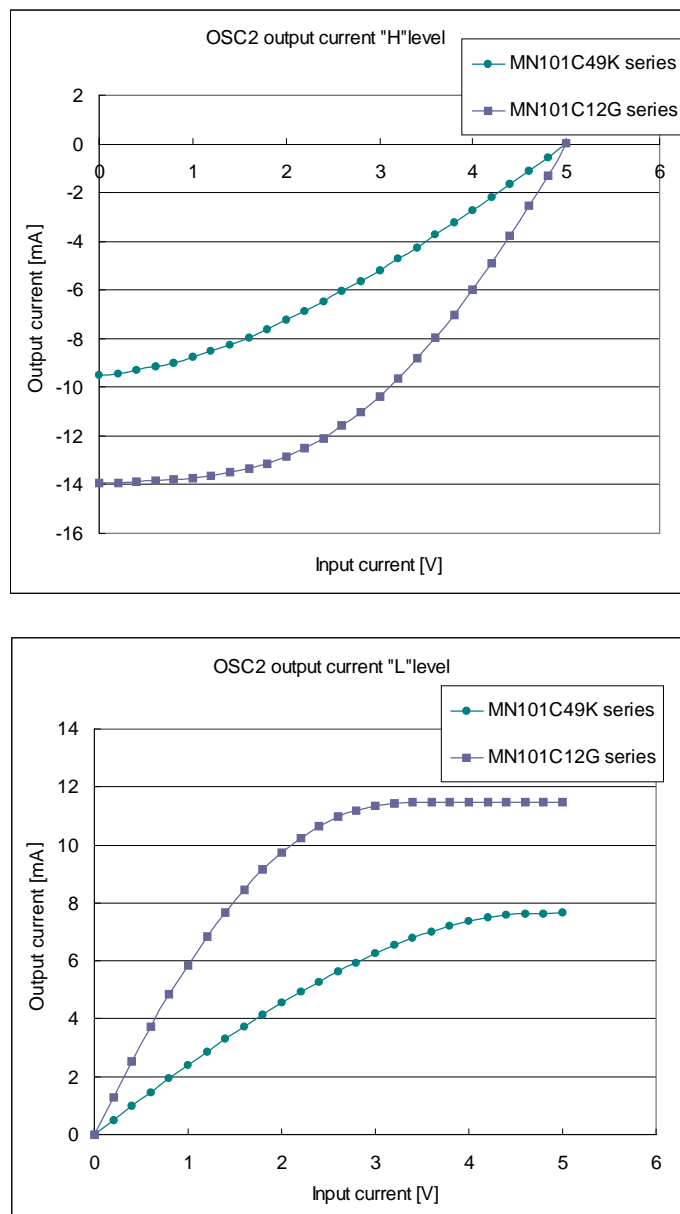
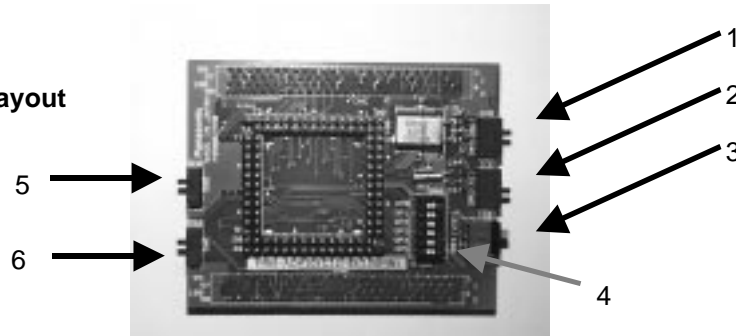


Figure 19-2-1 MN101C49K OSC2 pin's output current

## 19-3 Probe Switches (PRB-ADP101C12/49(100 PIN))

Adapter boards differ depending upon the models. This adapter board can be used for only 101C12/49 (100PIN). Use this adapter board with EV board, PRB-EV101C18. Improper matching may cause any damage to the ICE. The switches that the adapter board provides for configuring the probe are described below.

Adapter Board Layout



- (1)SW1 (Oscillator control) : Set this switch to its USR position to drive the in-circuit emulator with the oscillator built into the target device. If there is no target device, set this switch to the ICE position to use the oscillator built into the probe.
- (2)SW2 (XI control) : Set this switch to its USR position to drive the in-circuit emulator with the XI oscillator built into the target device. If there is no target device, set this switch to the ICE position to use oscillator built into the probe.
- (3)SW3 (Power supply control)  
: Set this switch to its USR position to use the power supply from the target device. If there is no target device, set this switch to the ICE position to use the 5 V power supply from the in-circuit emulator.
- (4)Function control DIP switches  
: Each model has different setting of DIPSW as described below.

OP0	ON	: Start with the SYSCLK standard division rate. (SYSCLK/2)
	OFF	: Start with the SYSCLK maximum division rate. (SYSCLK/64)
OP1	ON	: Start with the OSC oscillation.
	OFF	: Start with the XI/XO oscillation.
OP2	ON	: Set the timer input signal from port 4.
	OFF	: Set the timer input signal from port 1.
OP3	ON	: Operate the watchdog timer at reset is released.
	OFF	: Stop the watchdog timer at reset is released.
OP4	ON	: Reset by the hardware at the watchdog timer generation.
	OFF	: Reset by NMI (by the software) at the watchdog timer generation.
OP5	ON	: Start the oscillation at reset.
	OFF	: Stop the oscillation at reset.

Default control

OP0	<input type="checkbox"/>	ON
OP1	<input type="checkbox"/>	ON
OP2	<input checked="" type="checkbox"/>	OFF
OP3	<input checked="" type="checkbox"/>	OFF
OP4	<input checked="" type="checkbox"/>	OFF
OP5	<input type="checkbox"/>	ON

The following setup is necessary before this switch is used.

- (5)SW6 (MMOD control) : MMOD setup switch. Set this switch to its USR position to use the power supply from the external. And set it to its PRB position to use the power supply from the target device.
- (6)SW5 (MMOD : VDD-GND control)  
: This switch is used when SW6 is set to its PRB position. Set it to its VDD position when the VDD is supplied to the MMOD pin. Then, set it to its GND position when the GND is supplied.

## 19-4 Special Function Registers List

Address	Register	Bit Symbol / Initial Value / Description								Page
		Bit 7	Bit 6	Bit 5	Bit 4	Bit 3	Bit 2	Bit 1	Bit 0	
X'3F00'	CPUM	RESERVED	OSCESEL1	OSCESEL0	OSCDL	STOP	HALT	OSC1	OSC0	II - 25 II - 29
		0	0	0	0	0	0	0	0	
		Set always to "0"	Division Rate Setup		Internal System Clock Setup	STOP mode Setup	HALT mode Setup	Oscillation Control		
X'3F01'	MEMCTR	IOW1	IOW0	IVBM	EXMEM	EXWH	IRWE	EXW1	EXW0	II - 18
		1	1	0	0	1	0	1	1	
		I/O Wait Setup		Interrupt Vector Address	Switch Memory	Switch Wait	Software Writes Setup	Fixed Wait Setup		
X'3F02'	WDCTR	-	-	WDTC2	WDTC1	WDTC0	WDTS1	WDTS0	WDEN	IX - 3
		-	-	0	0	0	1	1	0	
		The lowest value for clear Setup					Watchdog Time-out Period Setup		WDT Activation	
X'3F03'	DLYCTR	BUZOE	BUZS2	BUZS1	BUZS0	DLYS1	DLYS0	-	-	II - 47 X - 3
		0	0	0	0	0	0	-	-	
		Enable Buzzer Output	Buzzer Output Frequency Setup			Oscillation Stabilization Wait Cycle Setup				
X'3F06'	ACTMD	WTSUP1	WTSUP0	WTHLD1	WTHLD0	RDSUP1	RDSUP0	RDHLD1	RDHLD0	XVIII - 2
		0	0	0	0	0	0	0	0	
		Specify Write Setup		Specify Write Hold		Specify Read Setup		Specify Read Hold		
X'3F09'	RCCTR	-	-	-	-	-	RC2EN	RC1EN	RC0EN	II - 38
		-	-	-	-	-	0	0	0	
		ROM Correction Control								
X'3F0A'	SBNKR	-	-	-	-	-	-	SBA1	SBA0	II - 32
		-	-	-	-	-	-	0	0	
		Bank for Source Address Setup								
X'3F0B'	DBNKR	-	-	-	-	-	-	DBA1	DBA0	II - 32
		-	-	-	-	-	-	0	0	
		Bank for Destination Address Setup								
X'3F0D'	OSCMD	-	-	-	-	-	-	SOSC2DS	RESERVED	II - 29
		-	-	-	-	-	-	0	0	
									Low Frequency Divided by 2	Fixed to "0"
X'3F0E'	EXADV	EXADV3	EXADV2	EXADV1	-	-	-	-	-	II - 19 IV - 34,41
		0	0	0	-	-	-	-	-	
		Address Pin Setup at Memory Expansion Mode								
X'3F10'	P0OUT	P0OUT7	P0OUT6	P0OUT5	P0OUT4	P0OUT3	P0OUT2	P0OUT1	P0OUT0	IV - 8
		x	x	x	x	x	x	x	x	
		Port 0 Output Data								
X'3F11'	P1OUT	P1OUT7	P1OUT6	P1OUT5	P1OUT4	P1OUT3	P1OUT2	P1OUT1	P1OUT0	IV - 14
		x	x	x	x	x	x	x	x	
		Port 1 Output Data								
X'3F12'	P2OUT	P2OUT7	-	-	-	-	-	-	-	IV - 20
		1	-	-	-	-	-	-	-	
		Port 2 Output Data								

Note) x : Initial value is unstable. - : No register is allocated.



Address	Register	Bit Symbol / Initial Value / Description								Page
		Bit 7	Bit 6	Bit 5	Bit 4	Bit 3	Bit 2	Bit 1	Bit 0	
X'3F13'	P3OUT	P3OUT7	P3OUT6	P3OUT5	P3OUT4	P3OUT3	P3OUT2	P3OUT1	P3OUT0	IV - 23
		x	x	x	x	x	x	x	x	
		Port 3 Output Data								
X'3F14'	P4OUT	P4OUT7	P4OUT6	P4OUT5	P4OUT4	P4OUT3	P4OUT2	P4OUT1	P4OUT0	IV - 29
		x	x	x	x	x	x	x	x	
		Port 4 Output Data								
X'3F15'	P5OUT	-	-	-	P5OUT4	P5OUT3	P5OUT2	P5OUT1	P5OUT0	IV - 33
		-	-	-	x	x	x	x	x	
		Port 5 Output Data								
X'3F16'	P6OUT	P6OUT7	P6OUT6	P6OUT5	P6OUT4	P6OUT3	P6OUT2	P6OUT1	P6OUT0	IV - 37
		x	x	x	x	x	x	x	x	
		Port 6 Output Data								
X'3F17'	P7OUT	P7OUT7	P7OUT6	P7OUT5	P7OUT4	P7OUT3	P7OUT2	P7OUT1	P7OUT0	IV - 40
		x	x	x	x	x	x	x	x	
		Port 7 Output Data								
X'3F18'	P8OUT	P8OUT7	P8OUT6	P8OUT5	P8OUT4	P8OUT3	P8OUT2	P8OUT1	P8OUT0	IV - 44
		x	x	x	x	x	x	x	x	
		Port 8 Output Data								
X'3F1C'	PCOUT	-	-	-	-	PCOUT3	PCOUT2	PCOUT1	PCOUT0	IV - 51
		-	-	-	-	x	x	x	x	
		Port C Output Data								
X'3F1D'	PDOUT	PDOUT7	PDOUT6	PDOUT5	PDOUT4	PDOUT3	PDOUT2	PDOUT1	PDOUT0	IV - 54
		x	x	x	x	x	x	x	x	
		Port D Output Data								
X'3F1F'	PDSYO	PDSYO7	PDSYO6	PDSYO5	PDSYO4	PDSYO3	PDSYO2	PDSYO1	PDSYO0	IV - 55
		0	0	0	0	0	0	0	0	
		Port D Synchronous Output Selection								
X'3F20'	P0IN	P0IN7	P0IN6	P0IN5	P0IN4	P0IN3	P0IN2	P0IN1	P0IN0	IV - 8
		x	x	x	x	x	x	x	x	
		Port 0 Input Data								
X'3F21'	P1IN	P1IN7	P1IN6	P1IN5	P1IN4	P1IN3	P1IN2	P1IN1	P1IN0	IV - 14
		x	x	x	x	x	x	x	x	
		Port 1 Input Data								
X'3F22'	P2IN	P2IN7	P2IN6	P2IN5	P2IN4	P2IN3	P2IN2	P2IN1	P2IN0	IV - 20
		1	x	x	x	x	x	x	x	
		Port 2 Input Data								
X'3F23'	P3IN	P3IN7	P3IN6	P3IN5	P3IN4	P3IN3	P3IN2	P3IN1	P3IN0	IV - 23
		x	x	x	x	x	x	x	x	
		Port 3 Input Data								
X'3F24'	P4IN	P4IN7	P4IN6	P4IN5	P4IN4	P4IN3	P4IN2	P4IN1	P4IN0	IV - 29
		x	x	x	x	x	x	x	x	
		Port 4 Input Data								

Note) x : Initial value is unstable. - : No data

Address	Register	Bit Symbol / Initial Value / Description								Page
		Bit 7	Bit 6	Bit 5	Bit 4	Bit 3	Bit 2	Bit 1	Bit 0	
X'3F25'	P5IN	-	-	-	P5IN4	P5IN3	P5IN2	P5IN1	P5IN0	IV - 33
		-	-	-	x	x	x	x	x	
		Port 5 Input data								
X'3F26'	P6IN	P6IN7	P6IN6	P6IN5	P6IN4	P6IN3	P6IN2	P6IN1	P6IN0	IV - 37
		x	x	x	x	x	x	x	x	
		Port 6 Input data								
X'3F27'	P7IN	P7IN7	P7IN6	P7IN5	P7IN4	P7IN3	P7IN2	P7IN1	P7IN0	IV - 40
		x	x	x	x	x	x	x	x	
		Port 7 Input data								
X'3F28'	P8IN	P8IN7	P8IN6	P8IN5	P8IN4	P8IN3	P8IN2	P8IN1	P8IN0	IV - 44
		x	x	x	x	x	x	x	x	
		Port 8 Input data								
X'3F2A'	PAIN	PAIN7	PAIN6	PAIN5	PAIN4	PAIN3	PAIN2	PAIN1	PAIN0	IV - 47
		x	x	x	x	x	x	x	x	
		Port A Input data								
X'3F2C'	PCIN	-	-	-	-	PCIN3	PCIN2	PCIN1	PCIN0	IV - 51
		-	-	-	-	x	x	x	x	
		Port C Input data								
X'3F2D'	PDIN	PDIN7	PDIN6	PDIN5	PDIN4	PDIN3	PDIN2	PDIN1	PDIN0	IV - 54
		x	x	x	x	x	x	x	x	
		Port D Input data								
X'3F2E'	FLOAT	-	PARDWN	-	P7RDWN	P4RDWN	-	SYOEVS1	SVOEVS0	IV - 30,41, 48,55
		-	0	-	0	0	-	0	0	
			PA Pull up/down Selection		P7 Pull up/down Selection	P4 Pull up/down Selection			PD Synchronous Output Event Selection	
X'3F2F'	P1OMD	-	P1OMD6	-	P1OMD4	P1OMD3	P1OMD2	P1OMD1	P1OMD0	IV - 15
		-	0	-	0	0	0	0	0	
			Port 1 Special Function Pin Output Control		Port 1 Special Function Pin Output Control					
X'3F30'	P0DIR	P0DIR7	P0DIR6	P0DIR5	P0DIR4	P0DIR3	P0DIR2	P0DIR1	P0DIR0	IV - 8
		0	0	0	0	0	0	0	0	
		Port 0 I/O Direction Control								
X'3F31'	P1DIR	P1DIR7	P1DIR6	P1DIR5	P1DIR4	P1DIR3	P1DIR2	P1DIR1	P1DIR0	IV - 14
		0	0	0	0	0	0	0	0	
		Port 1 I/O Direction Control								
X'3F33'	P3DIR	P3DIR7	P3DIR6	P3DIR5	P3DIR4	P3DIR3	P3DIR2	P3DIR1	P3DIR0	IV - 23
		0	0	0	0	0	0	0	0	
		Port 3 I/O Direction Control								
X'3F34'	P4DIR	P4DIR7	P4DIR6	P4DIR5	P4DIR4	P4DIR3	P4DIR2	P4DIR1	P4DIR0	IV - 29
		0	0	0	0	0	0	0	0	
		Port 4 I/O Direction Control								
X'3F35'	P5DIR	-	-	-	P5DIR4	P5DIR3	P5DIR2	P5DIR1	P5DIR0	IV - 33
		-	-	-	0	0	0	0	0	
		Port 5 I/O Direction Control								

Note) x : Initial value is unstable. - : No register is allocated.

Address	Register	Bit Symbol / Initial Value / Description								Page
		Bit 7	Bit 6	Bit 5	Bit 4	Bit 3	Bit 2	Bit 1	Bit 0	
X'3F36'	P6DIR	P6DIR7	P6DIR6	P6DIR5	P6DIR4	P6DIR3	P6DIR2	P6DIR1	P6DIR0	IV - 37
		0	0	0	0	0	0	0	0	
		Port 6 I/O Direction Control								
X'3F37'	P7DIR	P7DIR7	P7DIR6	P7DIR5	P7DIR4	P7DIR3	P7DIR2	P7DIR1	P7DIR0	IV - 40
		0	0	0	0	0	0	0	0	
		Port 7 I/O Direction Control								
X'3F38'	P8DIR	P8DIR7	P8DIR6	P8DIR5	P8DIR4	P8DIR3	P8DIR2	P8DIR1	P8DIR0	IV - 44
		0	0	0	0	0	0	0	0	
		Port 8 I/O Direction Control								
X'3F3A'	PAIMD	PAIMD7	PAIMD6	PAIMD5	PAIMD4	PAIMD3	PAIMD2	PAIMD1	PAIMD0	IV - 47
		0	0	0	0	0	0	0	0	
		Port A Analog Input Selection								
X'3F3C'	PCDIR	-	-	-	-	PCDIR3	PCDIR2	PCDIR1	PCDIR0	IV - 51
		-	-	-	-	0	0	0	0	
		Port C I/O Direction Control								
X'3F3D'	PDDIR	PDDIR7	PDDIR6	PDDIR5	PDDIR4	PDDIR3	PDDIR2	PDDIR1	PDDIR0	IV - 55
		0	0	0	0	0	0	0	0	
		Port D I/O Direction Control								
X'3F3E'	P4IMD	IRQ4SEL	-	-	-	P4KYEN4	P4KYEN3	P4KYEN2	P4KYEN1	III - 47
		0	-	-	-	0	0	0	0	
		IRQ4 Interrupt Source Selection	Port 4 Key Input Interrupt Pin Setup							
X'3F40'	P0PLU	P0PLU7	P0PLU6	P0PLU5	P0PLU4	P0PLU3	P0PLU2	P0PLU1	P0PLU0	IV - 8
		0	0	0	0	0	0	0	0	
		Port 0 Pull-up Control								
X'3F41'	P1PLU	P1PLU7	P1PLU6	P1PLU5	P1PLU4	P1PLU3	P1PLU2	P1PLU1	P1PLU0	IV - 14
		0	0	0	0	0	0	0	0	
		Port 1 Pull-up Control								
X'3F42'	P2PLU	-	P2PLU6	P2PLU5	P2PLU4	P2PLU3	P2PLU2	P2PLU1	P2PLU0	IV - 20
		-	0	0	0	0	0	0	0	
		Port 2 Pull-up Control								
X'3F43'	P3PLU	P3PLU7	P3PLU6	P3PLU5	P3PLU4	P3PLU3	P3PLU2	P3PLU1	P3PLU0	IV - 23
		0	0	0	0	0	0	0	0	
		Port 3 Pull-up Control								
X'3F44'	P4PLUD	P4PLUD7	P4PLUD6	P4PLUD5	P4PLUD4	P4PLUD3	P4PLUD2	P4PLUD1	P4PLUD0	IV - 29
		0	0	0	0	0	0	0	0	
		Port 4 Pull-up/Pull-down Control								
X'3F45'	P5PLU	-	-	-	P5PLU4	P5PLU3	P5PLU2	P5PLU1	P5PLU0	IV - 33
		-	-	-	0	0	0	0	0	
		Port 5 Pull-up Control								
X'3F46'	P6PLU	P6PLU7	P6PLU6	P6PLU5	P6PLU4	P6PLU3	P6PLU2	P6PLU1	P6PLU0	IV - 37
		0	0	0	0	0	0	0	0	
		Port 6 Pull-up Control								

Note) x : Initial value is unstable. - : No register is allocated.

Address	Register	Bit Symbol / Initial Value / Description								Page
		Bit 7	Bit 6	Bit 5	Bit 4	Bit 3	Bit 2	Bit 1	Bit 0	
X'3F47'	P7PLUD	P7PLUD7	P7PLUD6	P7PLUD5	P7PLUD4	P7PLUD3	P7PLUD2	P7PLUD1	P7PLUD0	IV - 40
		0	0	0	0	0	0	0	0	
		Port 7 Pull-up/Pull-down Control								
X'3F48'	P8PLU	P8PLU7	P8PLU6	P8PLU5	P8PLU4	P8PLU3	P8PLU2	P8PLU1	P8PLU0	IV - 44
		0	0	0	0	0	0	0	0	
		Port 8 Pull-up Control								
X'3F4A'	PAPLUD	PAPLUD7	PAPLUD6	PAPLUD5	PAPLUD4	PAPLUD3	PAPLUD2	PAPLUD1	PAPLUD0	IV - 47
		0	0	0	0	0	0	0	0	
		Port A Pull-up/Pull-down Control								
X'3F4C'	PCPLU	-	-	-	-	PCPLU3	PCPLU2	PCPLU1	PCPLU0	IV - 51
		-	-	-	-	0	0	0	0	
		Port C Pull-up Control								
X'3F4D'	PDPLU	PDPLU7	PDPLU6	PDPLU5	PDPLU4	PDPLU3	PDPLU2	PDPLU1	PDPLU0	IV - 54
		0	0	0	0	0	0	0	0	
		Port D Pull-up Control								
X'3F50'	TM0BC	TM0BC7	TM0BC6	TM0BC5	TM0BC4	TM0BC3	TM0BC2	TM0BC1	TM0BC0	VI - 10
		x	x	x	x	x	x	x	x	
		Timer 0 Binary Counter								
X'3F51'	TM1BC	TM1BC7	TM1BC6	TM1BC5	TM1BC4	TM1BC3	TM1BC2	TM1BC1	TM1BC0	VI - 10
		x	x	x	x	x	x	x	x	
		Timer 1 Binary Counter								
X'3F52'	TM0OC	TM0OC7	TM0OC6	TM0OC5	TM0OC4	TM0OC3	TM0OC2	TM0OC1	TM0OC0	VI - 9
		x	x	x	x	x	x	x	x	
		Timer 0 Output Compare Register								
X'3F53'	TM1OC	TM1OC7	TM1OC6	TM1OC5	TM1OC4	TM1OC3	TM1OC2	TM1OC1	TM1OC0	VI - 9
		x	x	x	x	x	x	x	x	
		Timer 1 Output Compare Register								
X'3F54'	TM0MD	-	-	TM0MOD	TM0PWM	TM0EN	TM0CK2	TM0CK1	TM0CK0	VI - 11
		-	-	0	0	0	0	0	0	
				Timer 0 Pulse Width Measurement	PWM Operation Selection	Timer 0 Count Control	Timer 0 Clock Source Selection			
X'3F55'	TM1MD	-	-	-	TM1CAS	TM1EN	TM1CK2	TM1CK1	TM1CK0	VI - 12
		-	-	-	0	0	0	0	0	
				Cascade Selection	Timer 1 Count Control	Timer 1 Clock Source Selection				
X'3F56'	CK0MD	-	-	-	-	-	TM0PSC1	TM0PSC0	TM0BAS	V - 7
		-	-	-	-	-	x	x	x	
		Timer 0 Count Clock Setting (Prescaler Output)								
X'3F57'	CK1MD	-	-	-	-	-	TM1PSC1	TM1PSC0	TM1BAS	V - 7
		-	-	-	-	-	x	x	x	
		Timer 1 Count Clock Setting (Prescaler Output)								
X'3F58'	TM2BC	TM2BC7	TM2BC6	TM2BC5	TM2BC4	TM2BC3	TM2BC2	TM2BC1	TM2BC0	VI - 10
		x	x	x	x	x	x	x	x	
		Timer 2 Binary Counter								

Note) x : Initial value is unstable. - : No data

Address	Register	Bit Symbol / Initial Value / Description								Page
		Bit 7	Bit 6	Bit 5	Bit 4	Bit 3	Bit 2	Bit 1	Bit 0	
X'3F59'	TM3BC	TM3BC7	TM3BC6	TM3BC5	TM3BC4	TM3BC3	TM3BC2	TM3BC1	TM3BC0	VI - 10
		x	x	x	x	x	x	x	x	
Timer 3 Binary Counter										
X'3F5A'	TM2OC	TM2OC7	TM2OC6	TM2OC5	TM2OC4	TM2OC3	TM2OC2	TM2OC1	TM2OC0	VI - 9
		x	x	x	x	x	x	x	x	
Timer 2 Output Compare Register										
X'3F5B'	TM3OC	TM3OC7	TM3OC6	TM3OC5	TM3OC4	TM3OC3	TM3OC2	TM3OC1	TM3OC0	VI - 9
		x	x	x	x	x	x	x	x	
Timer 3 Output Compare Register										
X'3F5C'	TM2MD	-	-	TM2MOD	TM2PWM	TM2EN	TM2CK2	TM2CK1	TM2CK0	VI - 13
		-	-	0	0	0	0	0	0	
				Timer 2 Pulse Width Measurement	PWM Operation Selection	Timer 2 Count Control	Timer 2 Clock Source Selection			
X'3F5D'	TM3MD	-	-	-	TM3CAS	TM3EN	TM3CK2	TM3CK1	TM3CK0	VI - 14
		-	-	-	0	0	0	0	0	
					Cascade Selection	Timer 3 Count Control	Timer 3 Clock Source Selection			
X'3F5E'	CK2MD	-	-	-	-	-	TM2PSC1	TM2PSC0	TM2BAS	V - 8
		-	-	-	-	-	x	x	x	
Timer 2 Count Clock Setting (Prescaler Output)										
X'3F5F'	CK3MD	-	-	-	-	-	TM3PSC1	TM3PSC0	TM3BAS	V - 8
		-	-	-	-	-	x	x	x	
Timer 3 Count Clock Setting (Prescaler Output)										
X'3F60'	TM4BC	TM4BC7	TM4BC6	TM4BC5	TM4BC4	TM4BC3	TM4BC2	TM4BC1	TM4BC0	VI - 10
		x	x	x	x	x	x	x	x	
Timer 4 Binary Counter										
X'3F62'	TM4OC	TM4OC7	TM4OC6	TM4OC5	TM4OC4	TM4OC3	TM4OC2	TM4OC1	TM4OC0	VI - 9
		x	x	x	x	x	x	x	x	
Timer 4 Output Compare Register										
X'3F64'	TM4MD	-	-	TM4MOD	TM4PWM	TM4EN	TM4CK2	TM4CK1	TM4CK0	VI - 15
		-	-	0	0	0	0	0	0	
				Timer 4 Pulse Width Measurement	PWM Operation Selection	Timer 4 Count Control	Timer 4 Clock Source Selection			
X'3F66'	CK4MD	-	-	-	-	-	TM4PSC1	TM4PSC0	TM4BAS	V - 9
		-	-	-	-	-	x	x	x	
Timer 4 Count Clock Setting (Prescaler Output)										
X'3F68'	TM6BC	TM6BC7	TM6BC6	TM6BC5	TM6BC4	TM6BC3	TM6BC2	TM6BC1	TM6BC0	VIII - 5
		x	x	x	x	x	x	x	x	
Timer 6 Binary Counter										
X'3F69'	TM6OC	TM6OC7	TM6OC6	TM6OC5	TM6OC4	TM6OC3	TM6OC2	TM6OC1	TM6OC0	VIII - 5
		x	x	x	x	x	x	x	x	
Timer 6 Output Compare Register										
X'3F6A'	TM6MD	TM6CLRS	TM6IR2	TM6IR1	TM6IR0	TM6CK3	TM6CK2	TM6CK1	TM6CK0	VIII - 6
		0	0	0	0	0	0	0	0	
		Counter Clear Selection	Time Base Timer Interrupt Cycle Selection			Timer 6 Clock Source Selection			Time Base Timer Clock Source Selection	

Note) x : Initial value is unstable. - : No register is allocated.

Address	Register	Bit Symbol / Initial Value / Description								Page
		Bit 7	Bit 6	Bit 5	Bit 4	Bit 3	Bit 2	Bit 1	Bit 0	
X'3F6B'	TBCLR	-	-	-	-	-	-	-	-	VIII - 5
		Time Base Timer Clear Control Register (For Writing Only)								
X'3F6E'	RMCTR	-	-	-	TM0RM	RMOEN	-	RMDTY0	RMBTMS	VI - 16
		-	-	-	0	0	-	0	0	
X'3F6F'	PSCMD	-	-	-	-	-	-	-	PSCEN	V - 6
		-	-	-	-	-	-	-	0	
X'3F70'	TM7BCL	TM7BCL7	TM7BCL6	TM7BCL5	TM7BCL4	TM7BCL3	TM7BCL2	TM7BCL1	TM7BCL0	VII - 7
		x	x	x	x	x	x	x	x	
Timer 7 Binary Counter Lower 8 Bits										
X'3F71'	TM7BCH	TM7BCH7	TM7BCH6	TM7BCH5	TM7BCH4	TM7BCH3	TM7BCH2	TM7BCH1	TM7BCH0	VII - 7
		x	x	x	x	x	x	x	x	
Timer 7 Binary Counter Upper 8 Bits										
X'3F72'	TM7OC1L	TM7OC1L7	TM7OC1L6	TM7OC1L5	TM7OC1L4	TM7OC1L3	TM7OC1L2	TM7OC1L1	TM7OC1L0	VII - 5
		x	x	x	x	x	x	x	x	
Timer 7 Output Compare Register 1 Lower 8 Bits										
X'3F73'	TM7OC1H	TM7OC1H7	TM7OC1H6	TM7OC1H5	TM7OC1H4	TM7OC1H3	TM7OC1H2	TM7OC1H1	TM7OC1H0	VII - 5
		x	x	x	x	x	x	x	x	
Timer 7 Output Compare Register 1 Upper 8 Bits										
X'3F74'	TM7PR1L	TM7PR1L7	TM7PR1L6	TM7PR1L5	TM7PR1L4	TM7PR1L3	TM7PR1L2	TM7PR1L1	TM7PR1L0	VII - 6
		x	x	x	x	x	x	x	x	
Timer 7 Preset Register 1 Lower 8 Bits										
X'3F75'	TM7PR1H	TM7PR1H7	TM7PR1H6	TM7PR1H5	TM7PR1H4	TM7PR1H3	TM7PR1H2	TM7PR1H1	TM7PR1H0	VII - 6
		x	x	x	x	x	x	x	x	
Timer 7 Preset Register 1 Upper 8 Bits										
X'3F76'	TM7ICL	TM7ICL7	TM7ICL6	TM7ICL5	TM7ICL4	TM7ICL3	TM7ICL2	TM7ICL1	TM7ICL0	VII - 7
		x	x	x	x	x	x	x	x	
Timer 7 Input Capture Register Lower 8 Bits										
X'3F77'	TM7ICH	TM7ICH7	TM7ICH6	TM7ICH5	TM7ICH4	TM7ICH3	TM7ICH2	TM7ICH1	TM7ICH0	VII - 7
		x	x	x	x	x	x	x	x	
Timer 7 Input Capture Register Upper 8 Bits										
X'3F78'	TM7MD1	RESERVED	RESERVED	TM7CL	TM7EN	TM7PS1	TM7PS0	TM7CK1	TM7CK0	VII - 8
		0	0	1	0	0	0	0	0	
		Fixed to "0"	Fixed to "0"	Timer 7 Output Reset Control	Timer 7 Count Control	Timer 7 Count Selection	Timer 7 Clock Source Selection			
X'3F79'	TM7MD2	T7ICEDG	T7PWMSL	TM7BCR	TM7PWM	TM7IRS1	T7ICEN	T7ICT1	T7ICT0	VII - 9
		0	0	0	0	0	0	0	0	
		Capture Trigger Edge Selection	PWM Mode Selection	Clear Factor Selection	Timer 7 Output Selection	Timer 7 Interrupt Factor Selection	Enable Capture Operation	Timer 7 Capture Trigger Selection		
X'3F7A'	TM7OC2L	TM7OC2L7	TM7OC2L6	TM7OC2L5	TM7OC2L4	TM7OC2L3	TM7OC2L2	TM7OC2L1	TM7OC2L0	VII - 5
		x	x	x	x	x	x	x	x	
Timer 7 Output Compare Register 2 Lower 8 Bits										

Note) x : Initial value is unstable. - : No register is allocated.

Address	Register	Bit Symbol / Initial Value / Description								Page
		Bit 7	Bit 6	Bit 5	Bit 4	Bit 3	Bit 2	Bit 1	Bit 0	
X'3F7B'	TM7OC2H	TM7OC2H7	TM7OC2H6	TM7OC2H5	TM7OC2H4	TM7OC2H3	TM7OC2H2	TM7OC2H1	TM7OC2H0	VII - 5
		x	x	x	x	x	x	x	x	
Timer 7 Output Compare Register 2 Upper 8 bits										
X'3F7C'	TM7PR2L	TM7PR2L7	TM7PR2L6	TM7PR2L5	TM7PR2L4	TM7PR2L3	TM7PR2L2	TM7PR2L1	TM7PR2L0	VII - 6
		x	x	x	x	x	x	x	x	
Timer 7 Preset Register 2 Lower 8 bits										
X'3F7D'	TM7PR2H	TM7PR2H7	TM7PR2H6	TM7PR2H5	TM7PR2H4	TM7PR2H3	TM7PR2H2	TM7PR2H1	TM7PR2H0	VII - 6
		x	x	x	x	x	x	x	x	
Timer 7 Preset Register 2 Upper 8 bits										
X'3F7E'	P1TCNT	-	-	P1CNT5	P1CNT4	P1CNT3	P1CNT2	P1CNT1	P1CNT0	IV - 16
		-	-	0	0	0	0	0	0	
				P14 Output Data Control		P12 Output Data Control		P10 Output Data Control		
X'3F8E'	NFCTR	P21IM	NF1SCK1	NF1SCK0	NF1EN	-	NF0SCK1	NF0SCK0	NF0EN	III - 45
		0	0	0	0	-	0	0	0	
		ACZ Input Enable Flag	IRQ1 Noise Filter Sampling Period Selection	IRQ1 Noise Filter Enable		IRQ0 Noise Filter Sampling Period Selection	IRQ0 Noise Filter Enable			
X'3F8F'	EDGDT	-	-	-	-	EDGSEL3	EDGSEL2	-	-	III - 46
		-	-	-	-	0	0	-	-	
						IRQ3 Both Edge Specification	IRQ2 Both Edge Specification			
X'3F90'	SC0MD0	SC0CE1	RESERVED	RESERVED	SC0DIR	SC0STE	SC0LNG2	SC0LNG1	SC0LNG0	XI - 6
		0	0	0	0	0	1	1	1	
		Transmission Data/Received Data Edge Selection	fixed to 0	fixed to 0	Specify First Bit to be Transferred	Start Condition Selection	Synchronous Serial Transfer Bit Count Selection			
X'3F91'	SC0MD1	SC0IOM	SC0SBTS	SC0SBIS	SC0SBOS	SC0CKM	SC0MST	-	SC0CMD	XI - 7
		0	0	0	0	0	0	-	0	
		Data Input Pin Selection	SBT Pin Function Selection	Serial Input Control	SBO Pin Function Selection	Clock Divided by 8 Selection	Master/Slave Selection		Synchronous/JART Selection	
X'3F92'	SC0MD2	SC0FM1	SC0FM0	SC0PM1	SC0PM0	SC0NPE	-	SC0BRKF	SC0BRKE	XI - 8
		0	0	0	0	0	-	0	0	
		Specify Flame Mode		Added Bit Specify		Parity Enable		Break Status Receive Monitor	Break Status Transmit Monitor	
X'3F93'	SC0STR	SC0TBSY	SC0RBSY	SC0TEMP	SC0REMP	SC0FEF	SC0PEK	SC0ORE	SC0ERE	XI - 9
		0	0	0	0	0	0	0	0	
		transmission flag	reception flag	Transfer Buffer Empty Flag	Receive Buffer Empty Flag	Framing Error Detection	Parity Error Detection	Overrun Error Detection	Error Monitor Flag	
X'3F94'	RXBUF0	RXBUF07	RXBUF06	RXBUF05	RXBUF04	RXBUF03	RXBUF02	RXBUF01	RXBUF00	XI - 5
		x	x	x	x	x	x	x	x	
Serial Interface 0 Receive Buffer										
X'3F95'	TXBUF0	TXBUF07	TXBUF06	TXBUF05	TXBUF04	TXBUF03	TXBUF02	TXBUF01	TXBUF00	XI - 5
		x	x	x	x	x	x	x	x	
Serial Interface 0 Transfer Buffer										
X'3F96'	SC0ODC	-	-	-	-	-	-	SC0ODC1	SC0ODC0	XI - 10
		-	-	-	-	-	-	0	0	
								P02 Output Type Selection	P00 Output Type Selection	
X'3F97'	SC0CKS	-	-	-	-	SC0TMSSEL	SC0PSC2	SC0PSC1	SC0PSC0	V - 10 XI - 10
		-	-	-	-	x	x	x	x	
Serial 0 Transfer Clock Selection (Prescaler Output, Timer Output)										

Note) x : Initial value is unstable. - : No register is allocated.

Address	Register	Bit Symbol / Initial Value / Description								Page
		Bit 7	Bit 6	Bit 5	Bit 4	Bit 3	Bit 2	Bit 1	Bit 0	
X'3F98'	RXBUF1	RXBUF17	RXBUF16	RXBUF15	RXBUF14	RXBUF13	RXBUF12	RXBUF11	RXBUF10	XII - 5
		x	x	x	x	x	x	x	x	
		Serial Interface 1 Receive Buffer								
X'3F99'	TXBUF1	TXBUF17	TXBUF16	TXBUF15	TXBUF14	TXBUF13	TXBUF12	TXBUF11	TXBUF10	XII - 5
		x	x	x	x	x	x	x	x	
		Serial Interface 1 Transfer Buffer								
X'3F9A'	SC1MD0	SC1CE1	SC1CE0	-	SC1DIR	SC1STE	SC1LNG2	SC1LNG1	SC1LNG0	XII - 6
		0	0	-	0	0	1	1	1	
		Transmission Data/Received Data Edge Selection			Specify First Bit to be Transferred	Start Condition Selection	Synchronous Serial Transfer Bit Count Selection			
X'3F9B'	SC1MD1	SC1IOM	SC1SBTS	SC1SBIS	SC1SBOS	SC1CKM	SC1MST	SC1ICC	SC1CMD	XII - 7
		0	0	0	0	0	0	0	0	
		Data Input Pin Selection	SBT Pin Function Selection	Serial Input Control	SBO Pin Function Selection	Clock Divided by 8 Selection	Master/Slave Selection	UART/ICC Selection	Synchronous/UART Selection	
X'3F9C'	SC1MD2	SC1FM1	SC1FM0	SC1PM1	SC1PM0	SC1NPE	-	SC1BRKF	SC1BRKE	XII - 8
		0	0	0	0	0	-	0	0	
		Specify Flame Mode		Added Bit Specify		Parity Enable		Break Status Receive Monitor	Break Status Transmit Monitor	
X'3F9D'	SC1STR	SC1BSY	-	SC1TEMP	SC1REMP	SC1FEF	SC1PEK	SC1ORE	SC1ERE	XII - 9
		0	-	0	0	0	0	0	0	
		Serial Bus Status		Transfer Buffer Empty Flag	Receive Buffer Empty Flag	Framing Error Detection	Parity Error Detection	Overrun Error Detection	Error Monitor Flag	
X'3F9E'	SC1ODC	-	-	-	-	-	-	SC1ODC1	SC1ODC0	XII - 10
		-	-	-	-	-	-	0	0	
								P32 Output Type Selection	P30 Output Type Selection	
X'3F9F'	SC1CKS	-	-	-	-	RESERVED	SC1PSC2	SC1PSC1	SC1PSC0	V - 10 XII - 10
		-	-	-	-	x	x	x	x	
						Set always to "1"	Serial 1 Transfer Clock Selection (Prescaler Output)			
X'3FA0'	SC2MD0	SC2BSY	SC2CE1	-	SC2DIR	SC2STE	SC2LNG2	SC2LNG1	SC2LNG0	XIII - 6
		0	0	-	0	0	1	1	1	
		Serial Bus Status	Transfer Edge Selection		Specify First Bit to be Transferred	Select Start Condition	Synchronous Serial Transfer bit Count Selection			
X'3FA1'	SC2MD1	SC2IOM	SC2SBTS	SC2SBIS	SC2SBOS	-	SC2MST	-	-	XIII - 7
		0	0	0	0	-	0	-	-	
		Data Input Pin Selection	SBT Pin Function Selection	Serial Input Control	SBO Pin Function Selection		Master/Slave Selection			
X'3FA2'	SC2TRB	SC2TRB7	SC2TRB6	SC2TRB5	SC2TRB4	SC2TRB3	SC2TRB2	SC2TRB1	SC2TRB0	XIII - 5
		x	x	x	x	x	x	x	x	
		Serial Interface 2 Transmission/Reception Shift Register								
X'3FA6'	SC2ODC	-	-	-	-	-	-	SC2ODC1	SC2ODC0	XIII - 8
		-	-	-	-	-	-	0	0	
								P05 Output Type Selection	P03 Output Type Selection	
X'3FA7'	SC2CKS	-	-	-	-	RESERVED	SC2PSC2	SC2PSC1	SC2PSC0	V - 11 XIII - 8
		-	-	-	-	x	x	x	x	
						Set always to "0"	Serial 2 Transfer Clock Selection (Prescaler Output)			
X'3FA8'	SC3MD0	SC3BSY	SC3CE1	-	SC3DIR	SC3STE	SC3LNG2	SC3LNG1	SC3LNG0	XIV - 6
		0	0	-	0	0	1	1	1	
		Serial Bus Status	Transfer Edge Selection		Specify First Bit to be Transferred	Select Start Condition	Synchronous Serial Transfer bit Count Selection			

Note) x : Initial value is unstable. - : No register is allocated.



Address	Register	Bit Symbol / Initial Value / Description								Page
		Bit 7	Bit 6	Bit 5	Bit 4	Bit 3	Bit 2	Bit 1	Bit 0	
X'3FA9'	SC3MD1	SC3IOM	SC3SBTS	SC3SBIS	SC3SBOS	-	SC3MST	-	-	XIV - 7
		0	0	0	0	-	0	-	-	
		Data Input Pin Selection	SBT Pin Function Selection	Serial Input Control	SBO Pin Function Selection		Master/Slave Selection			
X'3FAA'	SC3CTR	IICBSY	SC3STC	-	-	SC3REX	SC3CMD	SC3ACKS	SC3ACK0	XIV - 8
		0	0	-	-	0	0	0	0	
		Serial Bus Status at IIC	Start Condition Detection			Transmission/Reception Mode Selection at IIC	Synchronous/IIC Selection	ACK Bit Enable	ACK Bit Enable	
X'3FAB'	SC3TRB	SC3TRB7	SC3TRB6	SC3TRB5	SC3TRB4	SC3TRB3	SC3TRB2	SC3TRB1	SC3TRB0	XIV - 5
		x	x	x	x	x	x	x	x	
Serial Interface 3 Transmission/Reception Shift Register										
X'3FAE'	SC3ODC	-	-	-	-	-	-	SC3ODC1	SC3ODC0	XIV - 9
		-	-	-	-	-	-	0	0	
								P35 Output Type Selection	P33 Output Type Selection	
X'3FAF'	SC3CKS	-	-	-	-	RESERVED	SC3PSC2	SC3PSC1	SC3PSC0	V - 11 XIV - 9
		-	-	-	-	x	x	x	x	
						Set always to "0"	Serial 3 Transfer Clock Selection (Prescaler Output)			
X'3FB0'	ANCTR0	ANSH1	ANSH0	ANCK1	ANCK0	ANLADE	-	-	-	XVI - 5
		0	0	0	0	0	-	-	-	
		A/D Sample Hold Time Setup		A/D Conversion Clock Selection		A/D Rudder Resistance Control				
X'3FB1'	ANCTR1	-	-	-	-	RESERVED	ANCHS2	ANCHS1	ANCHS0	XVI - 6
		-	-	-	-	0	0	0	0	
						Set always to "0"	Analog Input Channel Selection			
X'3FB2'	ANCTR2	ANST	ANSTSEL	-	-	-	-	-	-	XVI - 6
		0	0	-	-	-	-	-	-	
		A/D Conversion Status	A/D Conversion Start Source Selection							
X'3FB3'	ANBUF0	ANBUF07	ANBUF06	-	-	-	-	-	-	XVI - 7
		x	x	-	-	-	-	-	-	
		A/D Conversion Data Storage Register (Lower 2 bits)								
X'3FB4'	ANBUF1	ANBUF17	ANBUF16	ANBUF15	ANBUF14	ANBUF13	ANBUF12	ANBUF11	ANBUF10	XVI - 7
		x	x	x	x	x	x	x	x	
		A/D Conversion Data Storage Register (Upper 2 bits)								
X'3FBB'	DACTR	-	-	DACKS2	DACKS1	DACMD3	DACMD2	DACMD1	DABUSY	XVII - 5
		-	-	x	x	x	x	x	0	
				D/A Scan Clock Selection		D/A Conversion Mode Selectio			D/A Conversion Enable Flag	
X'3FBC'	DADR0	DA0BUF7	DA0BUF6	DA0BUF5	DA0BUF4	DA0BUF3	DA0BUF2	DA0BUF1	DA0BUF0	XVII - 6
		x	x	x	x	x	x	x	x	
D/A Conversion Input Data (For DA0 Channel)										
X'3FBD'	DADR1	DA1BUF7	DA1BUF6	DA1BUF5	DA1BUF4	DA1BUF3	DA1BUF2	DA1BUF1	DA1BUF0	XVII - 6
		x	x	x	x	x	x	x	x	
		D/A Conversion Input Data (For DA1 Channel)								
X'3FBE'	DADR2	DA2BUF7	DA2BUF6	DA2BUF5	DA2BUF4	DA2BUF3	DA2BUF2	DA2BUF1	DA2BUF0	XVII - 6
		x	x	x	x	x	x	x	x	
		D/A Conversion Input Data (For DA Channel)								

Note) x : Initial value is unstable. - : No register is allocated.

Address	Register	Bit Symbol / Initial Value / Description								Page
		Bit 7	Bit 6	Bit 5	Bit 4	Bit 3	Bit 2	Bit 1	Bit 0	
X'3FBF'	DADR3	DA3BUF7	DA3BUF6	DA3BUF5	DA3BUF4	DA3BUF3	DA3BUF2	DA3BUF1	DA3BUF0	XVII - 6
		x	x	x	x	x	x	x	x	
D/A Conversion Input Data (For DA3 Channel)										
X'3FC7'	RC0APL	RC0APL7	RC0APL6	RC0APL5	RC0APL4	RC0APL3	RC0APL2	RC0APL1	RC0APL0	II - 39
		x	x	x	x	x	x	x	x	
ROM Correction Address 0 Setting Register Lower 8 bits										
X'3FC8'	RC0APM	RC0APM7	RC0APM6	RC0APM5	RC0APM4	RC0APM3	RC0APM2	RC0APM1	RC0APM0	II - 39
		x	x	x	x	x	x	x	x	
ROM Correction Address 0 Setting Register Middle 8 bits										
X'3FC9'	RC0APH	RC0APH7	RC0APH6	RC0APH5	RC0APH4	RC0APH3	RC0APH2	RC0APH1	RC0APH0	II - 39
		-	-	-	-	-	-	x	x	
ROM Correction Address 0 Setting Register Upper 2 bits										
X'3FCA'	RC1APL	RC1APL7	RC1APL6	RC1APL5	RC1APL4	RC1APL3	RC1APL2	RC1APL1	RC1APL0	II - 39
		x	x	x	x	x	x	x	x	
ROM Correction Address 1 Setting Register Lower 8 bits										
X'3FCB'	RC1APM	RC1APM7	RC1APM6	RC1APM5	RC1APM4	RC1APM3	RC1APM2	RC1APM1	RC1APM0	II - 39
		x	x	x	x	x	x	x	x	
ROM Correction Address 1 Setting Register Middle 8 bits										
X'3FCC'	RC1APH	RC1APH7	RC1APH6	RC1APH5	RC1APH4	RC1APH3	RC1APH2	RC1APH1	RC1APH0	II - 39
		-	-	-	-	-	-	x	x	
ROM Correction Address 1 Setting Register Upper 2 bits										
X'3FCD'	RC2APL	RC2APL7	RC2APL6	RC2APL5	RC2APL4	RC2APL3	RC2APL2	RC2APL1	RC2APL0	II - 40
		x	x	x	x	x	x	x	x	
ROM Correction Address 2 Setting Register Lower 8 bits										
X'3FCE'	RC2APM	RC2APM7	RC2APM6	RC2APM5	RC2APM4	RC2APM3	RC2APM2	RC2APM1	RC2APM0	II - 40
		x	x	x	x	x	x	x	x	
ROM Correction Address 2 Setting Register Middle 8 bits										
X'3FCF'	RC2APH	RC2APH7	RC2APH6	RC2APH5	RC2APH4	RC2APH3	RC2APH2	RC2APH1	RC2APH0	II - 40
		-	-	-	-	-	-	x	x	
ROM Correction Address 2 Setting Register Upper 2 bits										
X'3FD0'	ATCNT0	FMODE	AT1ACT	ATMD3	ATMD2	ATMD1	ATMD0	Reserved	AT1EN	XV - 6
		0	0	x	x	x	x	0	0	
		Pointer 0 Increment Control	ATC1 Software Activation Flag	ATC1 Data Transfer Mode				Set always to "0".	ATC1 Transfer Enable Flag	
X'3FD1'	ATCNT1	-	-	-	BTSTP	AT1IR3	AT1IR2	AT1IR1	AT1IR0	- XV - 7
		-	-	-	x	x	x	x	x	
Burst Transfer Enable Flag ATC1 Activation Factor Setting										
X'3FD2'	AT1TRC	AT1TRC7	AT1TRC6	AT1TRC5	AT1TRC4	AT1TRC3	AT1TRC2	AT1TRC1	AT1TRC0	XV - 7
		x	x	x	x	x	x	x	x	
ATC1 Transfer Count Setting										
X'3FD3'	AT1MAP0L	AT1MAP0L7	AT1MAP0L6	AT1MAP0L5	AT1MAP0L4	AT1MAP0L3	AT1MAP0L2	AT1MAP0L1	AT1MAP0L0	XV - 8
		x	x	x	x	x	x	x	x	
ATC1 Memory Pointer 0 Lower 8 bits										

Note) x : Initial value is unstable. - : No register is allocated.

Address	Register	Bit Symbol / Initial Value / Description								Page
		Bit 7	Bit 6	Bit 5	Bit 4	Bit 3	Bit 2	Bit 1	Bit 0	
X'3FD4'	AT1MAP0M	AT1MAP0M15	AT1MAP0M14	AT1MAP0M13	AT1MAP0M12	AT1MAP0M11	AT1MAP0M10	AT1MAP0M9	AT1MAP0M8	XV - 8
		x	x	x	x	x	x	x	x	
		ATC1 Memory Pointer 0 Middle 8 Bits								
X'3FD5'	AT1MAP0H	-	-	-	-	-	-	AT1MAP0H17	AT1MAP0H16	XV - 8
		-	-	-	-	-	-	x	x	
		ATC1 Memory Pointer 0 Upper 2 Bits								
X'3FD6'	AT1MAP1L	AT1MAP1L7	AT1MAP1L6	AT1MAP1L5	AT1MAP1L4	AT1MAP1L3	AT1MAP1L2	AT1MAP1L1	AT1MAP1L0	XV - 8
		x	x	x	x	x	x	x	x	
		ATC1 Memory Pointer 1 Lower 8 Bits								
X'3FD7'	AT1MAP1M	AT1MAP1L15	AT1MAP1L14	AT1MAP1M13	AT1MAP1M12	AT1MAP1M11	AT1MAP1M10	AT1MAP1M9	AT1MAP1M8	XV - 8
		x	x	x	x	x	x	x	x	
		ATC1 Memory Pointer 1 Middle 8 Bits								
X'3FD8'	AT1MAP1H	-	-	-	-	-	-	AT1MAP1H17	AT1MAP1H16	XV - 8
		-	-	-	-	-	-	x	x	
		ATC1 Memory Pointer 1 Upper 2 Bits								
X'3FE1'	NMICR	-	-	-	-	-	PIR	WDIR	RESERVED	III - 16
		-	-	-	-	-	0	0	0	
								Program Interrupt Request	Watchdog Timer Interrupt Request	
X'3FE2'	IRQ0ICR	IRQ0LV1	IRQ0LV0	REDG0	-	-	-	IRQ0IE	IRQ0IR	III - 18
		0	0	0	-	-	-	0	0	
		Specify IRQ0 Interrupt Level			IRQ0 Interrupt Valid Edge				Enable IRQ0 Interrupt	
X'3FE3'	IRQ1ICR	IRQ1LV1	IRQ1LV0	REDG1	-	-	-	IRQ1IE	IRQ1IR	III - 19
		0	0	0	-	-	-	0	0	
		Specify IRQ1 Interrupt Level			IRQ1 Interrupt Valid Edge				Enable IRQ1 Interrupt	
X'3FE4'	IRQ2ICR	IRQ2LV1	IRQ2LV0	REDG2	-	-	-	IRQ2IE	IRQ2IR	III - 20
		0	0	0	-	-	-	0	0	
		Specify IRQ2 Interrupt Level			IRQ2 Interrupt Valid Edge				Enable IRQ2 Interrupt	
X'3FE5'	IRQ3ICR	IRQ3LV1	IRQ3LV0	REDG3	-	-	-	IRQ3IE	IRQ3IR	III - 21
		0	0	0	-	-	-	0	0	
		Specify IRQ3 Interrupt Level			IRQ3 Interrupt Valid Edge				Enable IRQ3 Interrupt	
X'3FE6'	IRQ4ICR	IRQ4LV1	IRQ4LV0	REDG4	-	-	-	IRQ4IE	IRQ4IR	III - 22
		0	0	0	-	-	-	0	0	
		Specify IRQ4 Interrupt Level			IRQ4 Interrupt Valid Edge				Enable IRQ4 Interrupt	
X'3FE7'	IRQ5ICR	IRQ5LV1	IRQ5LV0	REDG5	-	-	-	IRQ5IE	IRQ5IR	III - 23
		0	0	0	-	-	-	0	0	
		Specify IRQ5 Interrupt Level			IRQ5 Interrupt Valid Edge				Enable IRQ5 Interrupt	
X'3FE9'	TM0ICR	TM0LV1	TM0LV0	-	-	-	-	TM0IE	TM0IR	III - 24
		0	0	-	-	-	-	0	0	
		Specify TM0 Interrupt Level							Enable TM0 Interrupt	
X'3FEA'	TM1ICR	TM1LV1	TM1LV0	-	-	-	-	TM1IE	TM1IR	III - 25
		0	0	-	-	-	-	0	0	
		Specify TM1 Interrupt Level							Enable TM1 Interrupt	

Note) x : Initial value is unstable. - : No register is allocated.

Address	Register	Bit Symbol / Initial Value / Description								Page
		Bit 7	Bit 6	Bit 5	Bit 4	Bit 3	Bit 2	Bit 1	Bit 0	
X'3FEB'	TM2ICR	TM2LV1	TM2LV0	-	-	-	-	TM2IE	TM2IR	III - 26
		0	0	-	-	-	-	0	0	
		Specify TM2 Interrupt Level						Enable TM2 Interrupt	Request TM2 Interrupt	
X'3FEC'	TM3ICR	TM3LV1	TM3LV0	-	-	-	-	TM3IE	TM3IR	III - 27
		0	0	-	-	-	-	0	0	
		Specify TM3 Interrupt Level						Enable TM3 Interrupt	Request TM3 Interrupt	
X'3FED'	TM4ICR	TM4LV1	TM4LV0	-	-	-	-	TM4IE	TM4IR	III - 28
		0	0	-	-	-	-	0	0	
		Specify TM4 Interrupt Level						Enable TM4 Interrupt	Request TM4 Interrupt	
X'3FEF'	TM6ICR	TM6LV1	TM6LV0	-	-	-	-	TM6IE	TM6IR	III - 29
		0	0	-	-	-	-	0	0	
		Specify TM6 Interrupt Level						Enable TM6 Interrupt	Request TM6 Interrupt	
X'3FF0'	TBICR	TBLV1	TBLV0	-	-	-	-	TBIE	TBIR	III - 30
		0	0	-	-	-	-	0	0	
		Specify TB Interrupt Level						Enable TB Interrupt	Request TB Interrupt	
X'3FF1'	TM7ICR	TM7LV1	TM7LV0	-	-	-	-	TM7IE	TM7IR	III - 31
		0	0	-	-	-	-	0	0	
		Specify TM7 Interrupt Level						Enable TM7 Interrupt	Request TM7 Interrupt	
X'3FF2'	T7OC2ICR	T7OC2LV1	T7OC2LV0	-	-	-	-	T7OC2IE	T7OC2IR	III - 32
		0	0	-	-	-	-	0	0	
		Specify T7OC2 Interrupt Level						Enable T7OC2 Interrupt	Request T7OC2 Interrupt	
X'3FF5'	SC0RICR	SC0RLV1	SC0RLV0	-	-	-	-	SC0RIE	SC0RIR	III - 33
		0	0	-	-	-	-	0	0	
		Specify SC0R Interrupt Level						Enable SC0R Interrupt	Request SC0R Interrupt	
X'3FF6'	SC0TICR	SC0TLV1	SC0TLV0	-	-	-	-	SC0TIE	SC0TIR	III - 34
		0	0	-	-	-	-	0	0	
		Specify SC0T Interrupt Level						Enable SC0T Interrupt	Request SC0T Interrupt	
X'3FF7'	SC1ICR	SC1LV1	SC1LV0	-	-	-	-	SC1IE	SC1IR	III - 35
		0	0	-	-	-	-	0	0	
		Specify SC1 Interrupt Level						Enable SC1 Interrupt	Request SC1 Interrupt	
X'3FF8'	SC2ICR	SC2LV1	SC2LV0	-	-	-	-	SC2IE	SC2IR	III - 36
		0	0	-	-	-	-	0	0	
		Specify SC2 Interrupt Level						Enable SC2 Interrupt	Request SC2 Interrupt	
X'3FF9'	SC3ICR	SC3LV1	SC3LV0	-	-	-	-	SC3IE	SC3IR	III - 37
		0	0	-	-	-	-	0	0	
		Specify SC3 Interrupt Level						Enable SC3 Interrupt	Request SC3 Interrupt	
X'3FFA'	ADICR	ADLV1	ADLV0	-	-	-	-	ADIE	ADIR	III - 38
		0	0	-	-	-	-	0	0	
		Specify AD Interrupt Level						Enable AD Interrupt	Request AD Interrupt	
X'3FFC'	ATC1ICR	ATC1LV1	ATC1LV0	-	-	-	-	ATC1IE	ATC1IR	III - 39
		0	0	-	-	-	-	0	0	
		Specify ATC1 Interrupt Level						Enable ATC1 Interrupt	Request ATC1 Interrupt	

Note) x : Initial value is unstable. - : No register is allocated.

# 19-5 Instruction Set

MN101C SERIES INSTRUCTION SET

Group	Mnemonic	Operation	Flag				Code Size	Cycle	Re-peat	Machine Code											Notes
			VF	NF	CF	ZF				Ext.	1	2	3	4	5	6	7	8	9	10	
Data Move Instructions																					
MOV	MOV Dn,Dm	Dn→Dm	--	--	--	--	2	1		1010	DnDm										
	MOV imm8,Dm	imm8→Dm	--	--	--	--	4	2		1010	DmDm <#8. ...>										
	MOV Dn,PSW	Dn→PSW	●	●	●	●	3	3		0010	1001 01Dn										
	MOV PSW,Dm	PSW→Dm	--	--	--	--	3	2		0010	0001 01Dm										
	MOV (An),Dm	mem8(An)→Dm	--	--	--	--	2	2		0100	1ADm										
	MOV (d8,An),Dm	mem8(d8+An)→Dm	--	--	--	--	4	2		0110	1ADm <d8. ...>								*1		
	MOV (d16,An),Dm	mem8(d16+An)→Dm	--	--	--	--	7	4		0010	0110 1ADm <d16 .... ...>										
	MOV (d4,SP),Dm	mem8(d4+SP)→Dm	--	--	--	--	3	2		0110	01Dm <d4>								*2		
	MOV (d8,SP),Dm	mem8(d8+SP)→Dm	--	--	--	--	5	3		0010	0110 01Dm <d8. ...>								*3		
	MOV (d16,SP),Dm	mem8(d16+SP)→Dm	--	--	--	--	7	4		0010	0110 00Dm <d16 .... ...>										
	MOV (io8),Dm	mem8(IOTOP+io8)→Dm	--	--	--	--	4	2		0110	00Dm <io8 ...>										
	MOV (abs8),Dm	mem8(abs8)→Dm	--	--	--	--	4	2		0100	01Dm <abs 8..>										
	MOV (abs12),Dm	mem8(abs12)→Dm	--	--	--	--	5	2		0100	00Dm <abs 12.. ...>										
	MOV (abs16),Dm	mem8(abs16)→Dm	--	--	--	--	7	4		0010	1100 00Dm <abs 16.. .... ...>										
	MOV Dn,(Am)	Dn→mem8(Am)	--	--	--	--	2	2		0101	1aDn										
	MOV Dn,(d8,Am)	Dn→mem8(d8+Am)	--	--	--	--	4	2		0111	1aDn <d8. ...>								*1		
	MOV Dn,(d16,Am)	Dn→mem8(d16+Am)	--	--	--	--	7	4		0010	0111 1aDn <d16 .... ...>										
	MOV Dn,(d4,SP)	Dn→mem8(d4+SP)	--	--	--	--	3	2		0111	01Dn <d4>								*2		
	MOV Dn,(d8,SP)	Dn→mem8(d8+SP)	--	--	--	--	5	3		0010	0111 01Dn <d8. ...>								*3		
	MOV Dn,(d16,SP)	Dn→mem8(d16+SP)	--	--	--	--	7	4		0010	0111 00Dn <d16 .... ...>										
	MOV Dn,(io8)	Dn→mem8(IOTOP+io8)	--	--	--	--	4	2		0111	00Dn <io8 ...>										
	MOV Dn,(abs8)	Dn→mem8(abs8)	--	--	--	--	4	2		0101	01Dn <abs 8..>										
	MOV Dn,(abs12)	Dn→mem8(abs12)	--	--	--	--	5	2		0101	00Dn <abs 12.. ...>										
	MOV Dn,(abs16)	Dn→mem8(abs16)	--	--	--	--	7	4		0010	1101 00Dn <abs 16.. .... ...>										
	MOV imm8,(io8)	imm8→mem8(IOTOP+io8)	--	--	--	--	6	3		0000	0010 <io8 ...> <#8. ...>										
	MOV imm8,(abs8)	imm8→mem8(abs8)	--	--	--	--	6	3		0001	0100 <abs 8..> <#8. ...>										
	MOV imm8,(abs12)	imm8→mem8(abs12)	--	--	--	--	7	3		0001	0101 <abs 12.. ...> <#8. ...>										
	MOV imm8,(abs16)	imm8→mem8(abs16)	--	--	--	--	9	5		0011	1101 1001 <abs 16.. .... ...> <#8. ...>										
MOV Dn,(HA)	Dn→mem8(HA)	--	--	--	--	2	2		1101	00Dn											
MOVW	MOVW (An),DWm	mem16(An)→DWm	--	--	--	--	2	3		1110	00Ad										
	MOVW (An),Am	mem16(An)→Am	--	--	--	--	3	4		0010	1110 10Aa								*4		
	MOVW (d4,SP),DWm	mem16(d4+SP)→DWm	--	--	--	--	3	3		1110	011d <d4>								*2		
	MOVW (d4,SP),Am	mem16(d4+SP)→Am	--	--	--	--	3	3		1110	010a <d4>								*2		
	MOVW (d8,SP),DWm	mem16(d8+SP)→DWm	--	--	--	--	5	4		0010	1110 011d <d8. ...>								*3		
	MOVW (d8,SP),Am	mem16(d8+SP)→Am	--	--	--	--	5	4		0010	1110 010a <d8. ...>								*3		
	MOVW (d16,SP),DWm	mem16(d16+SP)→DWm	--	--	--	--	7	5		0010	1110 001d <d16 .... ...>										
	MOVW (d16,SP),Am	mem16(d16+SP)→Am	--	--	--	--	7	5		0010	1110 000a <d16 .... ...>										
	MOVW (abs8),DWm	mem16(abs8)→DWm	--	--	--	--	4	3		1100	011d <abs 8..>										
	MOVW (abs8),Am	mem16(abs8)→Am	--	--	--	--	4	3		1100	010a <abs 8..>										
	MOVW (abs16),DWm	mem16(abs16)→DWm	--	--	--	--	7	5		0010	1100 011d <abs 16.. .... ...>										
	MOVW (abs16),Am	mem16(abs16)→Am	--	--	--	--	7	5		0010	1100 010a <abs 16.. .... ...>										
	MOVW DWn,(Am)	DWn→mem16(Am)	--	--	--	--	2	3		1111	00aD										
	MOVW An,(Am)	An→mem16(Am)	--	--	--	--	3	4		0010	1111 10aA								*4		
	MOVW DWn,(d4,SP)	DWn→mem16(d4+SP)	--	--	--	--	3	3		1111	011D <d4>								*2		
	MOVW An,(d4,SP)	An→mem16(d4+SP)	--	--	--	--	3	3		1111	010A <d4>								*2		
	MOVW DWn,(d8,SP)	DWn→mem16(d8+SP)	--	--	--	--	5	4		0010	1111 011D <d8. ...>								*3		
	MOVW An,(d8,SP)	An→mem16(d8+SP)	--	--	--	--	5	4		0010	1111 010A <d8. ...>								*3		
	MOVW DWn,(d16,SP)	DWn→mem16(d16+SP)	--	--	--	--	7	5		0010	1111 001D <d16 .... ...>										
	MOVW An,(d16,SP)	An→mem16(d16+SP)	--	--	--	--	7	5		0010	1111 000A <d16 .... ...>										
	MOVW DWn,(abs8)	DWn→mem16(abs8)	--	--	--	--	4	3		1101	011D <abs 8..>										
	MOVW An,(abs8)	An→mem16(abs8)	--	--	--	--	4	3		1101	010A <abs 8..>										
	MOVW DWn,(abs16)	DWn→mem16(abs16)	--	--	--	--	7	5		0010	1101 011D <abs 16.. .... ...>										
	MOVW An,(abs16)	An→mem16(abs16)	--	--	--	--	7	5		0010	1101 010A <abs 16.. .... ...>										
	MOVW DWn,(HA)	DWn→mem16(HA)	--	--	--	--	2	3		1001	010D										
	MOVW An,(HA)	An→mem16(HA)	--	--	--	--	2	3		1001	011A										
	MOVW imm8,DWm	sign(imm8)→DWm	--	--	--	--	4	2		0000	110d <#8. ...>								*5		
	MOVW imm8,Am	zero(imm8)→Am	--	--	--	--	4	2		0000	111a <#8. ...>								*6		
	MOVW imm16,DWm	imm16→DWm	--	--	--	--	6	3		1100	111d <#16 .... ...>										

\*1 d8 sign-extension \*4 A=An, a=Am  
 \*2 d4 zero-extension \*5 #8 sign-extension  
 \*3 d8 zero-extension \*6 #8 zero-extension

MN101C SERIES INSTRUCTION SET

Group	Mnemonic	Operation	Flag				Code Size	Cycle	Repeat	Extension	Machine Code											Notes	
			VF	NF	CF	ZF					1	2	3	4	5	6	7	8	9	10	11		
	MOVW imm16,Am	imm16→Am	--	--	--	--	6	3		1101 111a <#16 ... ..>													
	MOVW SP,Am	SP→Am	--	--	--	--	3	3		0010 0000 100a													
	MOVW An,SP	An→SP	--	--	--	--	3	3		0010 0000 101A													
	MOVW DWn,DWm	DWn→DWm	--	--	--	--	3	3		0010 1000 00Dd													*1
	MOVW DWn,Am	DWn→Am	--	--	--	--	3	3		0010 0100 11Da													
	MOVW An,DWm	An→DWm	--	--	--	--	3	3		0010 1100 11Ad													
PUSH	MOVW An,Am	An→Am	--	--	--	--	3	3		0010 0000 00Aa													*2
	PUSH Dn	SP-1→SP,Dn→mem8(SP)	--	--	--	--	2	3		1111 10Dn													
POP	PUSH An	SP-2→SP,An→mem16(SP)	--	--	--	--	2	5		0001 011A													
	POP Dn	mem8(SP)→Dn,SP+1→SP	--	--	--	--	2	3		1110 10Dn													
EXT	POP An	mem16(SP)→An,SP+2→SP	--	--	--	--	2	4		0000 011A													
	EXT Dn,DWm	sign(Dn)→DWm	--	--	--	--	3	3		0010 1001 000d													*3

Arithmetic manipulation instructions

ADD	ADD Dn,Dm	Dm+Dn→Dm	●	●	●	●	3	2		0011 0011 DnDm													
	ADD imm4,Dm	Dm+sign(imm4)→Dm	●	●	●	●	3	2		1000 00Dm <#4>												*6	
	ADD imm8,Dm	Dm+imm8→Dm	●	●	●	●	4	2		0000 10Dm <#8. ...>													
ADDC	ADDC Dn,Dm	Dm+Dn+CF→Dm	●	●	●	●	3	2	○	0011 1011 DnDm													
ADDW	ADDW DWn,DWm	DWm+DWn→DWm	●	●	●	●	3	3	○	0010 0101 00Dd													*1
	ADDW DWn,Am	Am+DWn→Am	●	●	●	●	3	3	○	0010 0101 10Da													
	ADDW imm4,Am	Am+sign(imm4)→Am	●	●	●	●	3	2		1110 110a <#4>													*6
	ADDW imm8,Am	Am+sign(imm8)→Am	●	●	●	●	5	3		0010 1110 110a <#8. ...>													*7
	ADDW imm16,Am	Am+imm16→Am	●	●	●	●	7	4		0010 0101 011a <#16 ... ..>													
	ADDW imm4,SP	SP+sign(imm4)→SP	--	--	--	--	3	2		1111 1101 <#4>													*6
	ADDW imm8,SP	SP+sign(imm8)→SP	--	--	--	--	4	2		1111 1100 <#8. ...>													*7
	ADDW imm16,SP	SP+imm16→SP	--	--	--	--	7	4		0010 1111 1100 <#16 ... ..>													
ADDW imm16,DWm	DWm+imm16→DWm	●	●	●	●	7	4		0010 0101 010d <#16 ... ..>														
ADDUW	ADDUW Dn,Am	Am+zero(Dn)→Am	●	●	●	●	3	3	○	0010 1000 1aDn													*8
ADDSW	ADDSW Dn,Am	Am+sign(Dn)→Am	●	●	●	●	3	3	○	0010 1001 1aDn													
SUB	SUB Dn,Dm (when Dn=Dm)	Dm-Dn→Dm	●	●	●	●	3	2	○	0010 1010 DnDm													
	SUB Dn,Dn	Dn-Dn→Dn	0	0	0	1	2	1		1000 01Dn													
	SUB imm8,Dm	Dm-imm8→Dm	●	●	●	●	5	3		0010 1010 DmDm <#8. ...>													
SUBC	SUBC Dn,Dm	Dm-Dn-CF→Dm	●	●	●	●	3	2	○	0010 1011 DnDm													
SUBW	SUBW DWn,DWm	DWm-DWn→DWm	●	●	●	●	3	3		0010 0100 00Dd													*1
	SUBW DWn,Am	Am-DWn→Am	●	●	●	●	3	3		0010 0100 10Da													
	SUBW imm16,DWm	DWm-imm16→DWm	●	●	●	●	7	4		0010 0100 010d <#16 ... ..>													
	SUBW imm16,Am	Am-imm16→Am	●	●	●	●	7	4		0010 0100 011a <#16 ... ..>													
MULU	MULU Dn,Dm	Dm*Dn→DWk	0	●	●	●	3	8		0010 1111 111D													*4
DIVU	DIVU Dn,DWm	DWm/Dn→DWm-l...DWm-h	●	●	●	●	3	9		0010 1110 111d													*5
CMP	CMP Dn,Dm	Dm-Dn...PSW	●	●	●	●	3	2		0011 0010 DnDm													
	CMP imm8,Dm	Dm-imm8...PSW	●	●	●	●	4	2		1100 00Dm <#8. ...>													
	CMP imm8,(abs8)	mem8(abs8)-imm8...PSW	●	●	●	●	6	3		0000 0100 <abs 8.> <#8. ...>													
	CMP imm8,(abs12)	mem8(abs12)-imm8...PSW	●	●	●	●	7	3		0000 0101 <abs 12.> <#8. ...>													
	CMP imm8,(abs16)	mem8(abs16)-imm8...PSW	●	●	●	●	9	5		0011 1101 1000 <abs 16.> <#8. ...>													
CMPW	CMPW DWn,DWm	DWm-DWn...PSW	●	●	●	●	3	3		0010 1000 01Dd													*1
	CMPW DWn,Am	Am-DWn...PSW	●	●	●	●	3	3		0010 0101 11Da													
	CMPW An,Am	Am-An...PSW	●	●	●	●	3	3		0010 0000 01Aa													*2
	CMPW imm16,DWm	DWm-imm16...PSW	●	●	●	●	6	3		1100 110d <#16 ... ..>													
	CMPW imm16,Am	Am-imm16...PSW	●	●	●	●	6	3		1101 110a <#16 ... ..>													

Logical manipulation instructions

AND	AND Dn,Dm	Dm&Dn→Dm	0	●	0	●	3	2		0011 0111 DnDm													
	AND imm8,Dm	Dm&imm8→Dm	0	●	0	●	4	2		0001 11Dm <#8. ...>													
	AND imm8,PSW	PSW&imm8→PSW	●	●	●	●	5	3		0010 1001 0010 <#8. ...>													
OR	OR Dn,Dm	Dm Dn→Dm	0	●	0	●	3	2		0011 0110 DnDm													
	OR imm8,Dm	Dm imm8→Dm	0	●	0	●	4	2		0001 10Dm <#8. ...>													
XOR	OR imm8,PSW	PSW imm8→PSW	●	●	●	●	5	3		0010 1001 0011 <#8. ...>													
	XOR Dn,Dm	Dm^Dn→Dm	0	●	0	●	3	2		0011 1010 DnDm													*9
	XOR imm8,Dm	Dm^imm8→Dm	0	●	0	●	5	3		0011 1010 DmDm <#8. ...>													

- \*1 D=DWn, d=DWm
- \*2 A=An, a=Am
- \*3 d=DWm
- \*4 D=DWk
- \*5 D=DWm
- \*6 #4 sign-extension
- \*7 #8 sign-extension
- \*8 Dn zero extension
- \*9 m≠n

MN101C SERIES INSTRUCTION SET

Group	Mnemonic	Operation	Flag				Code Size	Cycle	Repeat	Extension	Machine Code											Notes		
			VF	NF	CF	ZF					1	2	3	4	5	6	7	8	9	10	11			
NOT	NOT Dn	$\sim$ Dn→Dn=	0	●	0	●	3	2		0010	0010	10Dn												
ASR	ASR Dn	Dn.msb→temp,Dn.lsb→CF Dn>>1→Dn,temp→Dn.msb	0	--	●	●	3	2	○	0010	0011	10Dn												
LSR	LSR Dn	Dn.lsb→CF,Dn>>1→Dn 0→Dn.msb	0	0	●	●	3	2	○	0010	0011	11Dn												
ROR	ROR Dn	Dn.lsb→temp,Dn>>1→Dn CF→Dn.msb,temp→CF	0	●	●	●	3	2	○	0010	0010	11Dn												

Bit manipulation instructions

BSET	BSET (io8)bp	mem8(IOTOP+io8)&bpdata...PSW 1→mem8(IOTOP+io8)bp	0	●	0	●	5	5		0011	1000	0bp.	<io8	...>										
	BSET (abs8)bp	mem8(abs8)&bpdata...PSW 1→mem8(abs8)bp	0	●	0	●	4	4		1011	0bp.	<abs	8..>											
	BSET (abs16)bp	mem8(abs16)&bpdata...PSW 1→mem8(abs16)bp	0	●	0	●	7	6		0011	1100	0bp.	<abs	16..	....	...>								
BCLR	BCLR (io8)bp	mem8(IOTOP+io8)&bpdata...PSW 0→mem8(IOTOP+io8)bp	0	●	0	●	5	5		0011	1000	1bp.	<io8	...>										
	BCLR (abs8)bp	mem8(abs8)&bpdata...PSW 0→mem8(abs8)bp	0	●	0	●	4	4		1011	1bp.	<abs	8..>											
	BCLR (abs16)bp	mem8(abs16)&bpdata...PSW 0→mem8(abs16)bp	0	●	0	●	7	6		0011	1100	1bp.	<abs	16..	....	...>								
BTST	BTST imm8,Dm	Dm&imm8...PSW	0	●	0	●	5	3		0010	0000	11Dm	<#8.	...>										
	BTST (abs16)bp	mem8(abs16)&bpdata...PSW	0	●	0	●	7	5		0011	1101	0bp.	<abs	16..	....	...>								

Branch instructions

Bcc	BEQ label	if(ZF=1),PC+3+d4(label)+H→PC if(ZF=0),PC+3→PC	--	--	--	--	3	2/3		1001	000H	<d4>												*1	
	BEQ label	if(ZF=1),PC+4+d7(label)+H→PC if(ZF=0),PC+4→PC	--	--	--	--	4	2/3		1000	1010	<d7.	...H												*2
	BEQ label	if(ZF=1),PC+5+d11(label)+H→PC if(ZF=0),PC+5→PC	--	--	--	--	5	2/3		1001	1010	<d11	....	...H											*3
	BNE label	if(ZF=0),PC+3+d4(label)+H→PC if(ZF=1),PC+3→PC	--	--	--	--	3	2/3		1001	001H	<d4>													1
	BNE label	if(ZF=0),PC+4+d7(label)+H→PC if(ZF=1),PC+4→PC	--	--	--	--	4	2/3		1000	1011	<d7.	...H												*2
	BNE label	if(ZF=0),PC+5+d11(label)+H→PC if(ZF=1),PC+5→PC	--	--	--	--	5	2/3		1001	1011	<d11	....	...H											*3
	BGE label	if((VF^NF)=0),PC+4+d7(label)+H→PC if((VF^NF)=1),PC+4→PC	--	--	--	--	4	2/3		1000	1000	<d7.	...H												*2
	BGE label	if((VF^NF)=0),PC+5+d11(label)+H→PC if((VF^NF)=1),PC+5→PC	--	--	--	--	5	2/3		1001	1000	<d11	....	...H											*3
	BCC label	if(CF=0),PC+4+d7(label)+H→PC if(CF=1),PC+4→PC	--	--	--	--	4	2/3		1000	1100	<d7.	...H												*2
	BCC label	if(CF=0),PC+5+d11(label)+H→PC if(CF=1),PC+5→PC	--	--	--	--	5	2/3		1001	1100	<d11	....	...H											*3
	BCS label	if(CF=1),PC+4+d7(label)+H→PC if(CF=0),PC+4→PC	--	--	--	--	4	2/3		1000	1101	<d7.	...H												*2
	BCS label	if(CF=1),PC+5+d11(label)+H→PC if(CF=0),PC+5→PC	--	--	--	--	5	2/3		1001	1101	<d11	....	...H											*3
	BLT label	if((VF^NF)=1),PC+4+d7(label)+H→PC if((VF^NF)=0),PC+4→PC	--	--	--	--	4	2/3		1000	1110	<d7.	...H												*2
	BLT label	if((VF^NF)=1),PC+5+d11(label)+H→PC if((VF^NF)=0),PC+5→PC	--	--	--	--	5	2/3		1001	1110	<d11	....	...H											*3
	BLE label	if((VF^NF)ZF=1),PC+4+d7(label)+H→PC if((VF^NF)ZF=0),PC+4→PC	--	--	--	--	4	2/3		1000	1111	<d7.	...H												*2
	BLE label	if((VF^NF)ZF=1),PC+5+d11(label)+H→PC if((VF^NF)ZF=0),PC+5→PC	--	--	--	--	5	2/3		1001	1111	<d11	....	...H											*3
	BGT label	if((VF^NF)ZF=0),PC+5+d7(label)+H→PC if((VF^NF)ZF=1),PC+5→PC	--	--	--	--	5	3/4		0010	0010	0001	<d7.	...H											*2

\*1 d4 sign-extension  
\*2 d7 sign-extension  
\*3 d11 sign-extension





MN101C SERIES INSTRUCTION SET

Group	Mnemonic	Operation	Flag				Code Size	Cycle	Repeat	Extension	Machine Code											Notes	
			VF	NF	CF	ZF					1	2	3	4	5	6	7	8	9	10	11		
TBZ	TBZ (io8)bp,label	if(mem8((IOTOP+io8)bp=0),PC+7+d7(label)+H→PC if(mem8((IOTOP+io8)bp=1),PC+7→PC	0	●	0	●	7	6/7		0011 0100 0bp. <io8 ...> <d7. ...H													*1
	TBZ (io8)bp,label	if(mem8((IOTOP+io8)bp=0),PC+8+d11(label)+H→PC if(mem8((IOTOP+io8)bp=1),PC+8→PC	0	●	0	●	8	6/7		0011 0100 1bp. <io8 ...> <d11 .... ...H													*2
	TBZ (abs16)bp,label	if(mem8(abs16)bp=0),PC+9+d7(label)+H→PC if(mem8(abs16)bp=1),PC+9→PC	0	●	0	●	9	7/8		0011 1110 0bp. <abs 16.. .... ...> <d7. ...H													*1
	TBZ (abs16)bp,label	if(mem8(abs16)bp=0),PC+10+d11(label)+H→PC if(mem8(abs16)bp=1),PC+10→PC	0	●	0	●	10	7/8		0011 1110 1bp. <abs 16.. .... ...> <d11 .... ...H													*2
TBNZ	TBNZ (abs8)bp,label	if(mem8(abs8)bp=1),PC+7+d7(label)+H→PC if(mem8(abs8)bp=0),PC+7→PC	0	●	0	●	7	6/7		0011 0001 0bp. <abs 8.> <d7. ...H													*1
	TBNZ (abs8)bp,label	if(mem8(abs8)bp=1),PC+8+d11(label)+H→PC if(mem8(abs8)bp=0),PC+8→PC	0	●	0	●	8	6/7		0011 0001 1bp. <abs 8.> <d11 .... ...H													*2
	TBNZ (io8)bp,label	if(mem8(io)bp=1),PC+7+d7(label)+H→PC if(mem8(io)bp=0),PC+7→PC	0	●	0	●	7	6/7		0011 0101 0bp. <io8 ...> <d7. ...H													*1
	TBNZ (io8)bp,label	if(mem8(io)bp=1),PC+8+d11(label)+H→PC if(mem8(io)bp=0),PC+8→PC	0	●	0	●	8	6/7		0011 0101 1bp. <io8 ...> <d11 .... ...H													*2
	TBNZ (abs16)bp,label	if(mem8(abs16)bp=1),PC+9+d7(label)+H→PC if(mem8(abs16)bp=0),PC+9→PC	0	●	0	●	9	7/8		0011 1111 0bp. <abs 16.. .... ...> <d7. ...H													*1
	TBNZ (abs16)bp,label	if(mem8(abs16)bp=1),PC+10+d11(label)+H→PC if(mem8(abs16)bp=0),PC+10→PC	0	●	0	●	10	7/8		0011 1111 1bp. <abs 16.. .... ...> <d11 .... ...H													*2
JMP	JMP (An)	0→PC.17-16,An→PC.15-0→PC.H	---	---	---	---	3	4		0010 0001 00A0													
	JMP label	abs18(label)+H→PC	---	---	---	---	7	5		0011 1001 0aaH <abs 18.b p15~ 0.>													*5
JSR	JSR (An)	SP-3→SP,(PC+3).bp7-0→mem8(SP) (PC+3).bp15-8→mem8(SP+1) (PC+3).H→mem8(SP+2).bp7, 0→mem8(SP+2).bp6-2, (PC+3).bp17-16→mem8(SP+2).bp1-0 0→PC.bp17-16 An→PC.bp15-0→PC.H	---	---	---	---	3	7		0010 0001 00A1													
	JSR label	SP-3→SP,(PC+5).bp7-0→mem8(SP) (PC+5).bp15-8→mem8(SP+1) (PC+5).H→mem8(SP+2).bp7, 0→mem8(SP+2).bp6-2, (PC+5).bp17-16→mem8(SP+2).bp1-0 PC+5+d12(label)+H→PC	---	---	---	---	5	6		0001 000H <d12 .... ...>													*3
	JSR label	SP-3→SP,(PC+6).bp7-0→mem8(SP) (PC+6).bp15-8→mem8(SP+1) (PC+6).H→mem8(SP+2).bp7, 0→mem8(SP+2).bp6-2, (PC+6).bp17-16→mem8(SP+2).bp1-0 PC+6+d16(label)+H→PC	---	---	---	---	6	7		0001 001H <d16 .... ...>													*4
	JSR label	SP-3→SP,(PC+7).bp7-0→mem8(SP) (PC+7).bp15-8→mem8(SP+1) (PC+7).H→mem8(SP+2).bp7, 0→mem8(SP+2).bp6-2, (PC+7).bp17-16→mem8(SP+2).bp1-0 abs18(label)+H→PC	---	---	---	---	7	8		0011 1001 1aaH <abs 18.b p15~ 0.>													*5
	JSRV (tbl4)	SP-3→SP,(PC+3).bp7-0→mem8(SP) (PC+3).bp15-8→mem8(SP+1) (PC+3).H→mem8(SP+2).bp7 0→mem8(SP+2).bp6-2, (PC+3).bp17-16→mem8(SP+2).bp1-0 mem8(x'004080+tbl4<2>)→PC.bp7-0 mem8(x'004080+tbl4<2+1>)→PC.bp15-8 mem8(x'004080+tbl4<2+2>).bp7→PC.H mem8(x'004080+tbl4<2+2>).bp1-0→ PC.bp17-16	---	---	---	---	3	9		1111 1110 <t4>													
NOP	NOP	PC+2→PC	---	---	---	---	2	1	○	0000 0000													

\*1 d7 sign-extension  
 \*2 d11 sign-extension  
 \*3 d12 sign-extension  
 \*4 d16 sign-extension  
 \*5 aa=abs.18.17 - 16

MN101C SERIES INSTRUCTION SET

Group	Mnemonic	Operation	Flag				Code Size	Cycle	Repeat	Extension	Machine Code											Notes			
			VF	NF	CF	ZF					1	2	3	4	5	6	7	8	9	10	11				
RTS	RTS	mem8(SP)→(PC).bp7-0 mem8(SP+1)→(PC).bp15-8 mem8(SP+2).bp7→(PC).H mem8(SP+2).bp1-0→(PC).bp17-16 SP+3→SP	---	---	---	---	2	7		0000	0001														
RTI	RTI	mem8(SP)→PSW mem8(SP+1)→(PC).bp7-0 mem8(SP+2)→(PC).bp15-8 mem8(SP+3).bp7→(PC).H mem8(SP+3).bp1-0→(PC).bp17-16 mem8(SP+4)→HA-l mem8(SP+5)→HA-h SP+6→SP	●	●	●	●	2	11		0000	0011														
Control instructions																									
REP	REP imm3	imm3-1→RPC	---	---	---	---	3	2		0010	0001	1rep													*1

\*1 no repeat whn imm3=0, (rep: imm3-1)



Other than the instruction of MN101C Series, the assembler of this Series has the following instructions as macro instructions.

The assembler will interpret the macro instructions below as the assembler instructions.

macro instructions	replaced instructions	remarks
INC Dn	ADD 1,Dn	
DEC Dn	ADD -1,Dn	
INC An	ADDW 1,An	
DEC An	ADDW -1,An	
INC2 An	ADDW 2,An	
DEC2 An	ADDW -2,An	
CLR Dn	SUB Dn,Dm	n=m
ASL Dn	ADD Dn,Dm	n=m
LSL Dn	ADD Dn,Dm	n=m
ROL Dn	ADDC Dn,Dm	n=m
NEG Dn	NOT Dn ADD 1,Dn	
NOPL	MOVW DWn,DWm	n=m
MOV (SP),Dn	MOV (0,SP),Dn	
MOV Dn,(SP)	MOV Dn,(0,SP)	
MOVW (SP),DWn	MOVW (0,SP),DWn	
MOVW DWn,(SP)	MOVW DWn,(0,SP)	
MOVW (SP),An	MOVW (0,SP),An	
MOVW An,(SP)	MOVW An,(0,SP)	

# 19-6 Instruction Map

## MN101C SERIES INSTRUCTION MAP

1st nibble 2nd nibble

	0	1	2	3	4	5	6	7	8	9	A	B	C	D	E	F
0	NOP	RTS	MOV #8,(io8)	RTI	CMP #8,(abs8)/(abs12)	POP An	ADD #8,Dm			MOVW #8,DWm	MOVW #8,Am					
1	JSR d12(label)		JSR d16(label)		MOV #8,(abs8)/(abs12)		PUSH An		OR #8,Dm			AND #8,Dm				
2	When the extension code is b'0010'															
3	When the extension code is b'0011'															
4	MOV (abs12),Dm				MOV (abs8),Dm				MOV (An),Dm							
5	MOV Dn,(abs12)				MOV Dn,(abs8)				MOV Dn,(Am)							
6	MOV (io8),Dm				MOV (d4,SP),Dm				MOV (d8,An),Dm							
7	MOV Dn,(io8)				MOV Dn,(d4,SP)				MOV Dn,(d8,Am)							
8	ADD #4,Dm				SUB Dn,Dn				BGE d7	BRA d7	BEQ d7	BNE d7	BCC d7	BCS d7	BLT d7	BLE d7
9	BEQ d4		BNE d4		MOVW DWn,(HA)		MOVW An,(HA)		BGE d11	BRA d11	BEQ d11	BNE d11	BCC d11	BCS d11	BLT d11	BLE d11
A	MOV Dn,Dm / MOV #8,Dm															
B	BSET (abs8)bp								BCLR (abs8)bp							
C	CMP #8,Dm				MOVW (abs8),Am		MOVW (abs8),DWm		CBEQ #8,Dm,d7			CMPW #16,DWm		MOVW #16,DWm		
D	MOV Dn,(HA)				MOVW An,(abs8)		MOVW DWn,(abs8)		CBNE #8,Dm,d7			CMPW #16,Am		MOVW #16,Am		
E	MOVW (An),DWm				MOVW (d4,SP),Am		MOVW (d4,SP),DWm		POP Dn			ADDW #4,Am		BRA d4		
F	MOVW DWn,(Am)				MOVW An,(d4,SP)		MOVW DWn,(d4,SP)		PUSH Dn			ADDW #8,SP	ADDW #4,SP	JSRV (tbl4)		

Extension code: b'0010'

2nd nibble 3rd nibble

	0	1	2	3	4	5	6	7	8	9	A	B	C	D	E	F
0	MOVW An,Am				CMPW An,Am				MOVW SP,Am	MOVW An,SP	BTST #8,Dm					
1	JMP (A0)	JSR (A0)	JMP (A1)	JSR (A1)	MOV PSW,Dm				REP #3							
2		BGT d7	BHI d7	BLS d7	BNC d7	BNS d7	BVC d7	BVS d7	NOT Dn				ROR Dn			
3		BGT d11	BHI d11	BLS d11	BNC d11	BNS d11	BVC d11	BVS d11	ASR Dn				LSR Dn			
4	SUBW DWn,DWm				SUBW #16,DWm		SUBW #16,Am		SUBW DWn,Am			MOVW DWn,Am				
5	ADDW DWn,DWm				ADDW #16,DWm		ADDW #16,Am		ADDW DWn,Am			CMPW DWn,Am				
6	MOV (d16,SP),Dm				MOV (d8,SP),Dm				MOV (d16,An),Dm							
7	MOV Dn,(d16,SP)				MOV Dn,(d8,SP)				MOV Dn,(d16,Am)							
8	MOVW DWn,DWm (NOPL @n=m)				CMPW DWn,DWm				ADDUW Dn,Am							
9	EXT Dn,DWm		AND #8,PSW	OR #8,PSW	MOV Dn,PSW				ADDSW Dn,Am							
A	SUB Dn,Dm / SUB #8,Dm															
B	SUBC Dn,Dm															
C	MOV (abs16),Dm				MOVW (abs16),Am		MOVW (abs16),DWm		CBEQ #8,Dm,d12			MOVW An,DWm				
D	MOV Dn,(abs16)				MOVW An,(abs16)		MOVW DWn,(abs16)		CBNE #8,Dm,d12			CBEQ #8,(abs8),d7/d11		CBNE #8,(abs8),d7/d11		
E	MOVW (d16,SP),Am	MOVW (d16,SP),DWm	MOVW (d8,SP),Am	MOVW (d8,SP),DWm	MOVW (An),Am			ADDW #8,Am		DIVU						
F	MOVW An,(d16,SP)	MOVW DWn,(d16,SP)	MOVW An,(d8,SP)	MOVW DWn,(d8,SP)	MOVW An,(Am)			ADDW #16,SP			MULU					

Extension code: b'0011'  
 2nd nibble \ 3rd nibble

	0	1	2	3	4	5	6	7	8	9	A	B	C	D	E	F		
0	TBZ (abs8)bp,d7								TBZ (abs8)bp,d11									
1	TBNZ (abs8)bp,d7								TBNZ (abs8)bp,d11									
2	CMP Dn,Dm																	
3	ADD Dn,Dm																	
4	TBZ (io8)bp,d7								TBZ (io8)bp,d11									
5	TBNZ (io8)bp,d7								TBNZ (io8)bp,d11									
6	OR Dn,Dm																	
7	AND Dn,Dm																	
8	BSET (io8)bp								BCLR (io8)bp									
9	JMP abs18(label)								JSR abs18(label)									
A	XOR Dn,Dm / XOR #8,Dm																	
B	ADDC Dn,Dm																	
C	BSET (abs16)bp								BCLR (abs16)bp									
D	BTST (abs16)bp								cmp #8,(abs16)		mov #8,(abs16)				CBEQ #8,(abs16),d7/11		CBNE #8,(abs16),d7/11	
E	TBZ (abs16)bp,d7								TBZ (abs16)bp,d11									
F	TBNZ (abs16)bp,d7								TBNZ (abs16)bp,d11									

Ver2.1(2001.03.26)



## 20-1 Overview

### 20-1-1 Overview

The MN101CF49K is equivalent to MN101C49K except its Mask ROM is substituted with 224 KB of flash EEPROM. Normal operation is guaranteed with up to ten programmings.

The MN101CF49K is programmed in one of two modes; PROM writer mode, which uses a dedicated PROM writer for a microcontroller's stand-alone programming. Onboard programming mode, which the CPU controls programming of a microcontroller on a target board.

The 224 KB flash EEPROM is divided into two main areas.

Load program area (6 KB : x'04000' to x'57FF')

This area stores a load program for onboard programming mode. This area is written/erased only in PROM writer mode. This area is write/erase-protected in the hardware during onboard programming mode.

User program area (218 KB : x'05800' to x'3BFFF)

This area stores an user program. It is overwritten in both programming modes.



## 20-1-2 Differences between Mask ROM version and Flash EEPROM version

Table 20-1-1 shows differences between 8-bit microcontroller MN101C49G/49H/49K (Mask ROM version), MN101CP49K (EPROM version) and MN101CF49K (flash EEPROM version).

**Table 20-1-1 Differences between Mask ROM version and Flash EEPROM version**

	MN101C49G/49H/49K (Mask ROM version)	MN101CP49K (EPROM version)	MN101CF49K (Flash EEPROM version)
Operating temperature	- 40 °C to 85 °C	- 20 °C to 70 °C	- 20 °C to 70 °C
Operating voltage	4.5 V to 5.5 V ( at 0.1 ms / 20 MHz) 2.7 V to 5.5 V (at 0.238 ms / 8.39 MHz) 2.0 V to 5.5 V (at 1.00 ms / 2 MHz) 4.5 V to 5.5 V (at 0.119 ms / 8.39 MHz) 3.0 V to 5.5 V (at 0.25 ms / 4 MHz) 2.0 V to 5.5 V (at 61.04 ms / 32.768 kHz)	4.5 V to 5.5 V (at 0.1 ms / 20 MHz) 2.7 V to 5.5 V (at 0.238 ms / 8.39 MHz) 2.7 V to 5.5 V (at 1.00 ms / 2 MHz) 4.5 V to 5.5 V (at 0.119 ms / 8.39 MHz) 3.0 V to 5.5 V (at 0.25 ms / 4 MHz) 2.7 V to 5.5 V (at 61.04 ms / 32.768 kHz)	4.5 V to 5.5 V (at 0.1 ms / 20 MHz)   4.5 V to 5.5 V (at 0.119 ms / 8.39 MHz) 4.5 V to 5.5 V (at 61.04 ms / 32.768 kHz)
Pin DC characteristics	I/O currents, input judge levels are the same.		
Pin	P17, P26	P17, P26	P17, P26 => VPP, VDD2
Power supply pin	VDD	VDD	VDD1, VDD2, VPP
Oscillation characteristics	Matching evaluation of each oscillator is necessary when these versions are rotated for mass production		
Noise characteristics	Matching evaluation of each oscillator is necessary when these versions are rotated for mass production		

There are no other functional differences.



## 20-2 Pin Descriptions

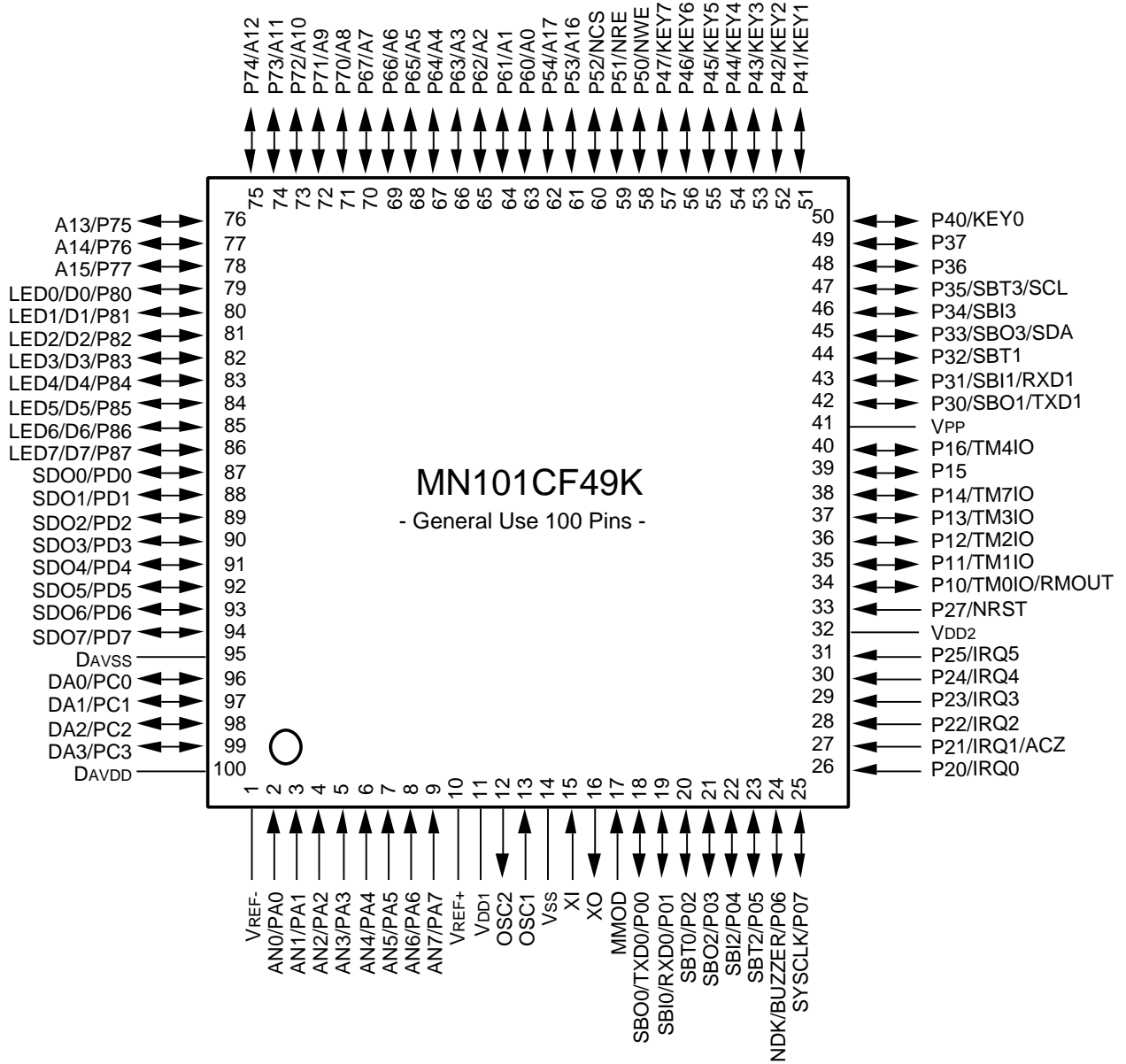


Figure20-2-1 Pin Configuration ( 100QFP : Top view )

Apply the same electric potential (VDD) to the power supply pins (VDD1, VDD2, VPP).

## 20-3 Electrical Characteristics

This LSI user's manual describes the standard specification. System clock (fs) is : 1/2 of high speed oscillation at NORMAL mode, or 1/4 of low speed oscillation at SLOW mode. Please ask our sales offices for its own product specifications.

Model	MN101C49K series
Contents	
Structure	CMOS integrated circuit
Application	General purpose
Function	CMOS 8-bit single-chip microcontroller

### 20-3-1 Absolute Maximum Ratings<sup>\*2,\*3</sup>

$$V_{DD1}=V_{DD2}=V_{PP}=V_{DD}$$

Parameter		Symbol	Rating	Unit	
1	Power supply voltage	$V_{DD}$	-0.3 to +7.0	V	
2	Input clamp current (ACZ)	$I_C$	-400 to 400	$\mu A$	
3	Input pin voltage	$V_I$	-0.3 to $V_{DD} + 0.3$	V	
4	Output pin voltage	$V_O$	-0.3 to $V_{DD} + 0.3$		
5	IO pin voltage	$V_{IO1}$	-0.3 to $V_{DD} + 0.3$ (except ACZ)		
6	Peak output current	Port 8	$I_{OL1}$ (peak)	30	mA
7		Other than port 8	$I_{OL2}$ (peak)	20	
8		All pins	$I_{OH}$ (peak)	-10	
9	Average output current *1	Port 8	$I_{OL1}$ (avg)	20	
10		Other than port 8	$I_{OL2}$ (avg)	15	
11		All pins	$I_{OH}$ (avg)	-5	
12	Power dissipation	$P_D$	400 ( $T_a=+70^{\circ}C$ )	mW	
13	Operating temperature	$T_{opr}$	-20 to +70	$^{\circ}C$	
14	Storage temperature	$T_{stg}$	-55 to +125		

\*1 Applied to any 100 ms period.

\*2 Connect at least one bypass capacitor of 0.1  $\mu F$  or larger between the power supply pin and the ground for latch-up prevention.

\*3 The absolute maximum ratings are the limit values beyond which the LSI may be damaged and proper operation is not assured.

## 20-3-2 Operating Conditions

[ NORMAL mode :  $f_s=f_{osc}/2$ , SLOW mode :  $f_s=f_x/4$ ,  $V_{DD1}=V_{DD2}=V_{PP}=V_{DD}$  ]

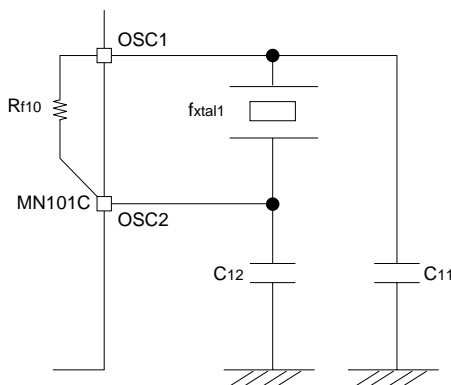
$T_a=-20\text{ }^\circ\text{C}$  to  $+70\text{ }^\circ\text{C}$   $V_{DD}=4.5\text{ V}$  to  $5.5\text{ V}$   $V_{SS}=0\text{ V}$

Parameter	Symbol	Conditions	Rating			Unit	
			MIN	TYP	MAX		
Power supply voltage							
1	Power supply voltage	$V_{DD10}$	$f_{osc}\leq 20.0\text{ MHz}$ [NORMAL mode : $f_s=f_{osc}/2$ ]	4.5	-	5.5	V
2		$V_{DD20}$	$f_{osc}\leq 8.39\text{ MHz}$ [2x-speed mode : $f_s=f_{osc}$ ]	4.5	-	5.5	
3		$V_{DD30}$	$f_x=32.768\text{ kHz}$	4.5	-	5.5	
4	Voltage to maintain RAM data	$V_{DD40}$	At STOP mode	1.8	-	5.5	
Operation speed *1							
5	Minimum instruction execution time	$t_{c10}$	$V_{DD}=4.5\text{ V}$ to $5.5\text{ V}$ [NORMAL mode : $f_s=f_{osc}/2$ ]	0.100	-	-	$\mu\text{s}$
6		$t_{c20}$	$V_{DD}=4.5\text{ V}$ to $5.5\text{ V}$ [2x-speed mode : $f_s=f_{osc}$ ]	0.119	-	-	
7		$t_{c30}$	$V_{DD}=4.5\text{ V}$ to $5.5\text{ V}$ [ $f_s=f_x/2$ ]	-	61.04	-	

- \*1  $t_{c10}$ ,  $t_{c20}$  : 1/2 of high speed oscillation  
 $t_{c30}$  : 1/4 of low speed oscillation

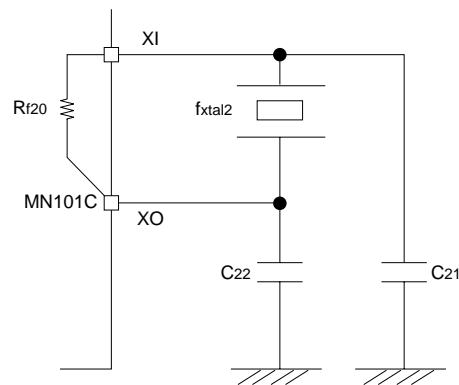
Ta=-20 °C to +70 °C V<sub>DD</sub>=4.5 V to 5.5 V V<sub>SS</sub>=0 V

Parameter	Symbol	Conditions	Rating			Unit
			MIN	TYP	MAX	
Crystal oscillator 1 Fig. 20-3-1						
8	Crystal frequency	f <sub>xtal1</sub>	V <sub>DD</sub> =4.5 V to 5.5 V			MHz
9	External capacitors	C <sub>11</sub>	-	20	-	pF
10		C <sub>12</sub>	-	20	-	
11	Internal feedback resistor	R <sub>f10</sub>	-	700	-	kΩ
Crystal oscillator 2 Fig. 20-3-2						
12	Crystal frequency	f <sub>xtal2</sub>	32.768	-	100	kHz
13	External capacitors	C <sub>21</sub>	-	20	-	pF
14		C <sub>22</sub>	-	20	-	
15	Internal feedback resistor	R <sub>f20</sub>	-	4.0	-	MΩ




The feedback resistor is built-in.

**Figure 20-3-1 Crystal Oscillator 1**



The feedback resistor is built-in.

**Figure 20-3-2 Crystal Oscillator 2**

 Connect external capacitors that suit for used oscillator. When crystal oscillator or ceramic oscillator is used, the oscillation frequency is changed depending on condenser. Consult the oscillator manufacturer for suitable external capacitor.

Ta=-20 °C to +70 °C V<sub>DD</sub>=4.5 V to 5.5 V V<sub>SS</sub>=0 V

Parameter	Symbol	Conditions	Rating			Unit
			MIN	TYP	MAX	
External clock input 1 OSC1 (OSC2 is unconnected)						
16	Clock frequency	f <sub>osc</sub>	1.0	-	20.0	MHz
17	High level pulse width	t <sub>wh1</sub>	*2 Fig. 20-4-3	-	30.0	ns
18	Low level pulse width	t <sub>wl1</sub>				
19	Rising time	t <sub>wr1</sub>	Fig. 20-4-3	-	5.0	
20	Falling time	t <sub>wf1</sub>				
External clock input 2 XI (XO is unconnected)						
21	Clock frequency	f <sub>x</sub>	32.768	-	100	kHz
22	High level pulse width	t <sub>wh2</sub>	*2 Fig. 20-4-4	-	-	μs
23	Low level pulse width	t <sub>wl2</sub>				
24	Rising time	t <sub>wr2</sub>	Fig. 20-4-4	-	20	ns
25	Falling time	t <sub>wf2</sub>				

\*2 The clock duty rate in standard mode should be 45% to 55%.

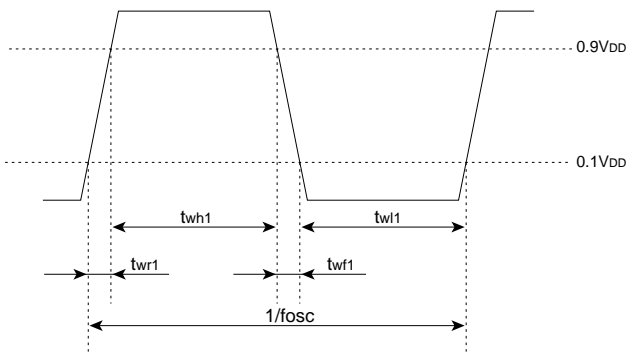


Figure 20-3-3 OSC1 Timing Chart

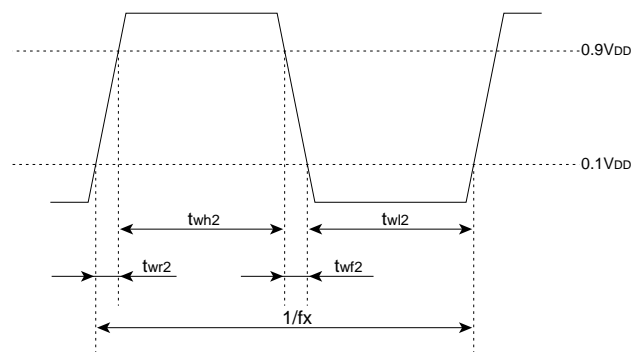


Figure 20-3-4 XI Timing Chart

### 20-3-3 DC Characteristics

$T_a = -20\text{ }^{\circ}\text{C}$  to  $+70\text{ }^{\circ}\text{C}$   $V_{DD} = 4.5\text{ V}$  to  $5.5\text{ V}$   $V_{SS} = 0\text{ V}$

Parameter	Symbol	Conditions	Rating			Unit	
			MIN	TYP	MAX		
Power supply current (no load at output pin) *1							
1	Power supply current	$I_{DD1}$	$f_{osc} = 20.0\text{ MHz}$ $V_{DD} = 5\text{ V}$ [NORMAL mode : $f_s = f_{osc}/2$ ]	-	30	70	mA
2		$I_{DD2}$	$f_{osc} = 8.39\text{ MHz}$ $V_{DD} = 5\text{ V}$ [NORMAL mode : $f_s = f_{osc}/2$ ]	-	15	30	
3		$I_{DD3}$	$f_x = 32.768\text{ kHz}$ $V_{DD} = 5\text{ V}$ [ $f_s = f_x/4$ ]	-	40	120	
4	Supply current during HALT mode	$I_{DD4}$	$f_x = 32.768\text{ kHz}$ $V_{DD} = 5\text{ V}$ $T_a = 25\text{ }^{\circ}\text{C}$	-	13	30	$\mu\text{A}$
5		$I_{DD5}$	$f_x = 32.768\text{ kHz}$ $V_{DD} = 5\text{ V}$ $T_a = +70\text{ }^{\circ}\text{C}$	-	-	90	
6	Supply current during STOP mode	$I_{DD6}$	$V_{DD} = 5\text{ V}$ $T_a = 25\text{ }^{\circ}\text{C}$	-	0	3	
7		$I_{DD7}$	$V_{DD} = 5\text{ V}$ $T_a = +70\text{ }^{\circ}\text{C}$	-	-	60	

\*1 Measured under conditions of no load.

- The supply current during operation,  $I_{DD1}(I_{DD2})$ , is measured under the following conditions :  
After all I/O pins are set to input mode and the oscillation is set to <NORMAL mode>, the MMOD pin is at  $V_{SS}$  level, the input pins are at  $V_{DD}$  level, and a 20 MHz (8.39 MHz) square wave of  $V_{DD}$  and  $V_{SS}$  amplitudes is input to the OSC1 pin.
- The supply current during operation,  $I_{DD3}$ , is measured under the following conditions :  
After all I/O pins are set to input mode and the oscillation is set to <SLOW mode>, the MMOD pin is at  $V_{SS}$  level, the input pins are at  $V_{DD}$  level, and a 32.768 kHz square wave of  $V_{DD}$  and  $V_{SS}$  amplitudes is input to the XI pin.
- The supply current during HALT mode,  $I_{DD4}(I_{DD5})$ , is measured under the following conditions :  
After all I/O pins are set to input mode and the oscillation is set to <HALT mode>, the MMOD pin is at  $V_{SS}$  level, the input pins are at  $V_{DD}$  level, and an 32.768 kHz square wave of  $V_{DD}$  and  $V_{SS}$  amplitudes is input to the XI pin.
- The supply current during STOP mode,  $I_{DD6}(I_{DD7})$ , is measured under the following conditions :  
After the oscillation is set to <STOP mode>, the MMOD pin is at  $V_{SS}$  level, the input pins are at  $V_{DD}$  level, and the OSC1 and XI pins are unconnected.

$T_a = -20\text{ }^{\circ}\text{C to } +70\text{ }^{\circ}\text{C}$   $V_{DD} = 4.5\text{ V to } 5.5\text{ V}$   $V_{SS} = 0\text{ V}$ 

Parameter	Symbol	Conditions	Rating			Unit	
			MIN	TYP	MAX		
Input pin 1 MMOD							
8	Input high voltage 1	$V_{IH1}$		$0.8 V_{DD}$	-	$V_{DD}$	V
9	Input high voltage 2	$V_{IH2}$	$V_{DD} = 4.5\text{ V to } 5.5\text{ V}$	$0.7 V_{DD}$	-	$V_{DD}$	
10	Input low voltage 1	$V_{IL1}$		0	-	$0.2 V_{DD}$	
11	Input low voltage 2	$V_{IL2}$	$V_{DD} = 4.5\text{ V to } 5.5\text{ V}$	0	-	$0.3 V_{DD}$	
12	Input leakage current	$I_{LK1}$	$V_I = 0\text{ V to } V_{DD}$	-	-	$\pm 10$	$\mu\text{A}$
Input pin 2 P20, P22 to P25(Schmitt trigger input)							
13	Input high voltage	$V_{IH3}$		$0.8 V_{DD}$	-	$V_{DD}$	V
14	Input low voltage	$V_{IL3}$		0	-	$0.2 V_{DD}$	
15	Input leakage current	$I_{LK3}$	$V_I = 0\text{ V to } V_{DD}$	-	-	$\pm 10$	$\mu\text{A}$
16	Input high current	$I_{IH3}$	$V_{DD} = 5.0\text{ V}$ $V_I = 1.5\text{ V}$ Pull-up resistor ON	-30	-100	-300	
Input pin 3-1 P21(Schmitt trigger input)							
17	Input high voltage	$V_{IH4}$		$0.8 V_{DD}$	-	$V_{DD}$	V
18	Input low voltage	$V_{IL4}$		0	-	$0.2 V_{DD}$	
19	Input leakage current	$I_{LK4}$	$V_I = 0\text{ V to } V_{DD}$	-	-	$\pm 10$	$\mu\text{A}$
20	Input high current	$I_{IH4}$	$V_{DD} = 5.0\text{ V}$ $V_I = 1.5\text{ V}$ Pull-up resistor ON	-30	-100	-300	
Input pin 3-2 P21(when used as ACZ) $V_{DD} = 5.0\text{ V}$							
21	High detection voltage	$V_{DLH}$	Fig. 20-4-5	-	-	3.5	V
22		$V_{DHL}$		1.5	-	-	
23	Low detection voltage	$V_{DHH}$		4.5	-	-	
24		$V_{DLL}$		-	-	0.5	
25	Input leakage current	$I_{LK10}$	$V_I = 0\text{ V to } V_{DD}$	-	-	$\pm 10$	$\mu\text{A}$
26	Input clamp current	$I_{C10}$	$V_I > V_{DD}$ $V_I < 0\text{ V}$	-	-	$\pm 400$	
ACZ pins							
27	Rising time	$t_{rs}$	Fig. 20-4-5	30	-	-	$\mu\text{s}$
28	Falling time	$t_{fs}$		30	-	-	

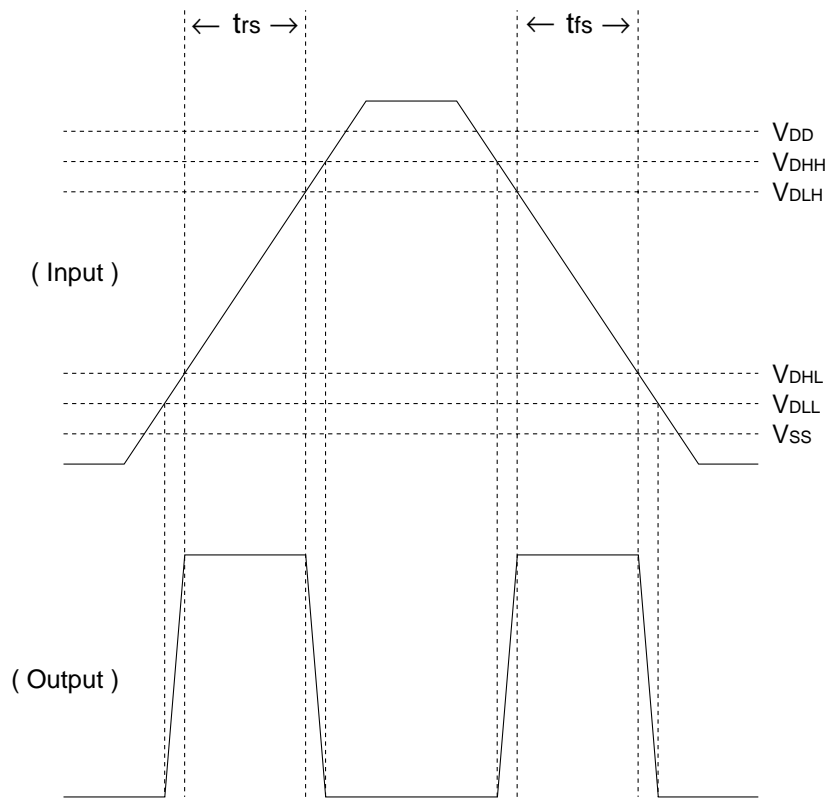


Figure 20-3-5 AC Zero-Cross Detector



Ta=-20 °C to +70 °C V<sub>DD</sub>=4.5 V to 5.5 V V<sub>SS</sub>=0 V

Parameter	Symbol	Conditions	Rating			Unit	
			MIN	TYP	MAX		
Input pin 4 PA0 to PA7							
29	Input high voltage 1	V <sub>IH5</sub>		0.8 V <sub>DD</sub>	-	V <sub>DD</sub>	V
30	Input high voltage 2	V <sub>IH6</sub>	V <sub>DD</sub> =4.5 V to 5.5 V	0.7 V <sub>DD</sub>	-	V <sub>DD</sub>	
31	Input low voltage 1	V <sub>IL5</sub>		0	-	0.2 V <sub>DD</sub>	
32	Input low voltage 2	V <sub>IL6</sub>	V <sub>DD</sub> =4.5 V to 5.5 V	0	-	0.3 V <sub>DD</sub>	
33	Input leakage current	I <sub>LK5</sub>	V <sub>I</sub> =0 V to V <sub>DD</sub>	-	-	± 2	μA
34	Input high current	I <sub>IH5</sub>	V <sub>DD</sub> =5.0 V V <sub>I</sub> =1.5 V Pull-up resistor ON	-30	-100	-300	
35	Input low current	I <sub>IL5</sub>	V <sub>DD</sub> =5.0 V V <sub>I</sub> =3.5 V Pull-down resistor ON	30	100	300	
I/O pin 5 P27 (NRST)							
36	Input high voltage	V <sub>IH7</sub>		0.8 V <sub>DD</sub>	-	V <sub>DD</sub>	V
37	Input low voltage	V <sub>IL7</sub>		0	-	0.15 V <sub>DD</sub>	
38	Input high current	I <sub>IH7</sub>	V <sub>DD</sub> =5.0 V V <sub>I</sub> =1.5 V Pull-up resistor ON	-30	-100	-300	μA
I/O pin 6 P00 to P07, P10 to P16, P30 to P37, PC0 to PC3, PD0 to PD7 (Schmitt trigger input except PC0 to PC3)							
39	Input high voltage	V <sub>IH8</sub>		0.8 V <sub>DD</sub>	-	V <sub>DD</sub>	V
40	Input low voltage	V <sub>IL8</sub>		0	-	0.2 V <sub>DD</sub>	
41	Input leakage current	I <sub>LK8</sub>	V <sub>I</sub> =0 V to V <sub>DD</sub>	-	-	±10	μA
42	Input high current	I <sub>IH8</sub>	V <sub>DD</sub> =5.0 V V <sub>I</sub> =1.5 V Pull-up resistor ON	-30	-100	-300	
43	Output high voltage	V <sub>OH8</sub>	V <sub>DD</sub> =5.0 V I <sub>OH</sub> =-0.5 mA	4.5	-	-	V
44	Output low voltage	V <sub>OL8</sub>	V <sub>DD</sub> =5.0 V I <sub>OL</sub> =1.0 mA	-	-	0.5	
I/O pin 7 P40 to P47							
45	Input high voltage	V <sub>IH9</sub>		0.8 V <sub>DD</sub>	-	V <sub>DD</sub>	V
46	Input low voltage	V <sub>IL9</sub>		0	-	0.2 V <sub>DD</sub>	
47	Input leakage current	I <sub>LK9</sub>	V <sub>I</sub> =0 V to V <sub>DD</sub>	-	-	± 10	μA
48	Input high current	I <sub>IH9</sub>	V <sub>DD</sub> =5.0 V V <sub>I</sub> =1.5 V Pull-up resistor ON	-30	-100	-300	
49	Input low current	I <sub>IL9</sub>	V <sub>DD</sub> =5.0 V V <sub>I</sub> =3.5 V Pull-down resistor ON	30	100	300	
50	Output high voltage	V <sub>OH9</sub>	V <sub>DD</sub> =5.0 V I <sub>OL</sub> =0.5 mA	4.5	-	-	V
51	Output low voltage	V <sub>OL9</sub>	V <sub>DD</sub> =5.0 V I <sub>OL</sub> =1.0 mA	-	-	0.5	

Ta=-20 °C to +70 °C V<sub>DD</sub>=4.5 V to 5.5 V V<sub>SS</sub>=0 V

Parameter	Symbol	Conditions	Rating			Unit	
			MIN	TYP	MAX		
Input pin 8 P50 to P54,P60 to P67							
52	Input high voltage 1	V <sub>IH10</sub>		0.8 V <sub>DD</sub>	-	V <sub>DD</sub>	V
53	Input high voltage 2	V <sub>IH11</sub>	V <sub>DD</sub> =4.5 V to 5.5 V	0.7 V <sub>DD</sub>	-	V <sub>DD</sub>	
54	Input low voltage 1	V <sub>IL10</sub>		0	-	0.2 V <sub>DD</sub>	
55	Input low voltage 2	V <sub>IL11</sub>	V <sub>DD</sub> =4.5 V to 5.5 V	0	-	0.3 V <sub>DD</sub>	
56	Input leakage current	I <sub>LK10</sub>	V <sub>I</sub> =0 V to V <sub>DD</sub>	-	-	± 10	μA
57	Input high current	I <sub>IH10</sub>	V <sub>DD</sub> =5.0 V V <sub>I</sub> =1.5 V Pull-up resistor ON	-30	-100	-300	
58	Output high current	V <sub>OH10</sub>	V <sub>DD</sub> =5.0 V I <sub>OH</sub> =-0.5 mA	4.5	-	-	V
59	Output low current	V <sub>OL10</sub>	V <sub>DD</sub> =5.0 V I <sub>OL</sub> =1.0 mA	-	-	0.5	
I/O pin 9 P70 to P77							
60	Input high voltage 1	V <sub>IH12</sub>		0.8 V <sub>DD</sub>	-	V <sub>DD</sub>	V
61	Input high voltage 2	V <sub>IH13</sub>	V <sub>DD</sub> =4.5 V to 5.5 V	0.7 V <sub>DD</sub>	-	V <sub>DD</sub>	
62	Input low voltage 1	V <sub>IL12</sub>		0	-	0.2 V <sub>DD</sub>	
63	Input low voltage 2	V <sub>IL13</sub>	V <sub>DD</sub> =4.5 V to 5.5 V	0	-	0.3 V <sub>DD</sub>	
64	Input leakage current	I <sub>LK12</sub>	V <sub>I</sub> =0 V to V <sub>DD</sub>	-	-	± 10	μA
65	Input high current	I <sub>IH12</sub>	V <sub>DD</sub> =5.0 V V <sub>I</sub> =1.5 V Pull-up resistor ON	-30	-100	-300	
66	Input low voltage	I <sub>IL12</sub>	V <sub>DD</sub> =5.0 V V <sub>I</sub> =3.5 V Pull-down resistor ON	30	100	300	
67	Output high voltage	V <sub>OH12</sub>	V <sub>DD</sub> =5.0 V I <sub>OH</sub> =-0.5 mA	4.5	-	-	V
68	Output low voltage	V <sub>OL12</sub>	V <sub>DD</sub> =5.0 V I <sub>OL</sub> =1.0 mA	-	-	0.5	
I/O pin 10 P80 to P87							
69	Input high voltage 1	V <sub>IH14</sub>		0.8 V <sub>DD</sub>	-	V <sub>DD</sub>	V
70	Input high voltage 2	V <sub>IH15</sub>	V <sub>DD</sub> =4.5 V to 5.5 V	0.7 V <sub>DD</sub>	-	V <sub>DD</sub>	
71	Input low voltage 1	V <sub>IL14</sub>		0	-	0.2 V <sub>DD</sub>	
72	Input low voltage 2	V <sub>IL15</sub>	V <sub>DD</sub> =4.5 V to 5.5 V	0	-	0.3 V <sub>DD</sub>	
73	Input leakage current	I <sub>LK14</sub>	V <sub>I</sub> =0 V to V <sub>DD</sub>	-	-	± 10	μA
74	Input high current	I <sub>IH14</sub>	V <sub>DD</sub> =5.0 V V <sub>I</sub> =1.5 V Pull-up resistor ON	-30	-100	-300	
75	Output high voltage	V <sub>OH14</sub>	V <sub>DD</sub> =5.0 V I <sub>OH</sub> =-0.5 mA	4.5	-	-	V
76	Output low voltage	V <sub>OL14</sub>	V <sub>DD</sub> =5.0 V I <sub>OL</sub> =15 mA	-	-	1.0	

## 20-3-4 A/D Converter Characteristics

$T_a = -20\text{ }^{\circ}\text{C}$  to  $+70\text{ }^{\circ}\text{C}$   $V_{DD} = 4.5\text{ V}$  to  $5.5\text{ V}$   $V_{SS} = 0\text{ V}$

Parameter	Symbol	Conditions	Rating			Unit	
			MIN	TYP	MAX		
1	Resolution		-	-	10	Bits	
2	Non-linearity error 1	$V_{DD} = 5.0\text{ V}$ $V_{SS} = 0\text{ V}$ $V_{REF+} = 5.0\text{ V}$ $V_{REF-} = 0\text{ V}$ $T_{AD} = 800\text{ ns}$	-	-	$\pm 3$	LSB	
3	Differential non-linearity error 1		-	-	$\pm 3$		
4	Non-linearity error 2		-	-	$\pm 5$		
5	Differential non-linearity error 2	$V_{DD} = 5.0\text{ V}$ $V_{SS} = 0\text{ V}$ $V_{REF+} = 5.0\text{ V}$ $V_{REF-} = 0\text{ V}$ $f_{OSC} = 32.768\text{ kHz}$	-	-	$\pm 5$		
6	Zero transition voltage	$V_{DD} = 5.0\text{ V}$ $V_{SS} = 0\text{ V}$ $V_{REF+} = 5.0\text{ V}$ $V_{REF-} = 0\text{ V}$ $T_{AD} = 800\text{ ns}$	-	30	100	mV	
7	Full-scale transition voltage		-	30	100		
8	A/D conversion time	$T_{AD} = 800\text{ ns}$	9.6	-	-	$\mu\text{s}$	
9		$f_x = 32.768\text{ kHz}$	-	-	183		
10	Sampling time	$f_{OSC} = 8\text{ MHz}$	1.0	-	36		
11		$f_x = 32.768\text{ kHz}$	-	30.5	-		
12	Reference voltage	$V_{REF+}$	2.0	-	$V_{DD}$	V	
13		$V_{REF-}$	$V_{SS}$	-	3.0		
14	Analog input voltage		$V_{REF-}$	-	$V_{REF+}$		
15	Analog input leakage current	$V_{ADIN} = 0\text{ V}$ to $5.0\text{ V}$ unselected channel	-	-	$\pm 2$	$\mu\text{A}$	
16	Reference voltage pin input leakage current	$V_{REF-} \leq V_{REF+} \leq V_{DD}$ at $V_{REF+}$ OFF	-	-	$\pm 10$		
17	Ladder resistance	$R_{LADD}$	$V_{DD} = 5.0\text{ V}$	20	50	80	$\text{k}\Omega$

\* Parameter 2 to 5 are rated values under the condition of  $V_{DD} = V_{REF+} = 5.0\text{ V}$ , and  $V_{SS} = V_{REF-} = 0\text{ V}$ .

## 20-3-5 D/A Converter Characteristics

$T_a = -20\text{ }^{\circ}\text{C}$  to  $+70\text{ }^{\circ}\text{C}$   $V_{DD} = 4.5\text{ V}$  to  $5.5\text{ V}$   $V_{SS} = 0\text{ V}$

Parameter	Symbol	Conditions	Rating			Unit
			MIN	TYP	MAX	
1	Resolution		-	-	8	Bits
2	Reference voltage low level	$D_{AVSS}$	0	-	1.0	V
3	Reference voltage high level	$D_{AVDD}$	4.0	-	$V_{DD}$	
4	Zero-scale output voltage	$V_{ZS}$ $D_{AVSS}=0\text{ V}$ $D_{AVDD}=5.0\text{ V}$ D7 to D0=ALL "L"	-0.05	0	0.05	
5	Full-scale output voltage	$V_{FS}$ $D_{AVSS}=0\text{ V}$ $D_{AVDD}=5.0\text{ V}$ D7 to D0=ALL "H"	4.93	4.98	5.03	
6	Analog output resistance (minimum reference resistance)	$R_{OAT}$	6	10	14	$k\Omega$
7	Non-linearity error	$N_{LE}$ $D_{AVSS}=0\text{ V}$ $D_{AVDD}=5.0\text{ V}$	-	$\pm 0.5$	$\pm 1.0$	LSB
8	Differential non-linearity error	$D_{NLE}$ $D_{AVSS}=0\text{ V}$ $D_{AVDD}=5.0\text{ V}$	-	$\pm 2.0$	$\pm 3.0$	
9	Settling time	$T_{SET}$ External capacitor $C_L=35\text{ pF}$ All bits are set to ON or OFF.	-	1.5	3.0	$\mu\text{s}$
10	Reference voltage pin input leakage current		-	-	$\pm 10$	$\mu\text{A}$

\* Parameter 7 and 8 are rated values under the condition of  $V_{DD}=D_{AVDD}=5.0\text{ V}$ , and  $V_{SS}=D_{AVSS}=0\text{ V}$ .

## 20-4 Reprogramming Flow

Figure 20-4-1 shows the flow for reprogramming (erasing and programming) the flash EEPROM.

As the figure shows, the write occurs after the memory is completely erased. The erase routine consists of three steps, first writing all zeros (x'00') to the entire memory space, next erasing the memory, and finally reversing, which is executed when bit is over-erased.

On this LSI, above procedure is repeated in every 128 KB with switching of the MEMSEL, which occurs automatically by the PROM writer that determines the address space.

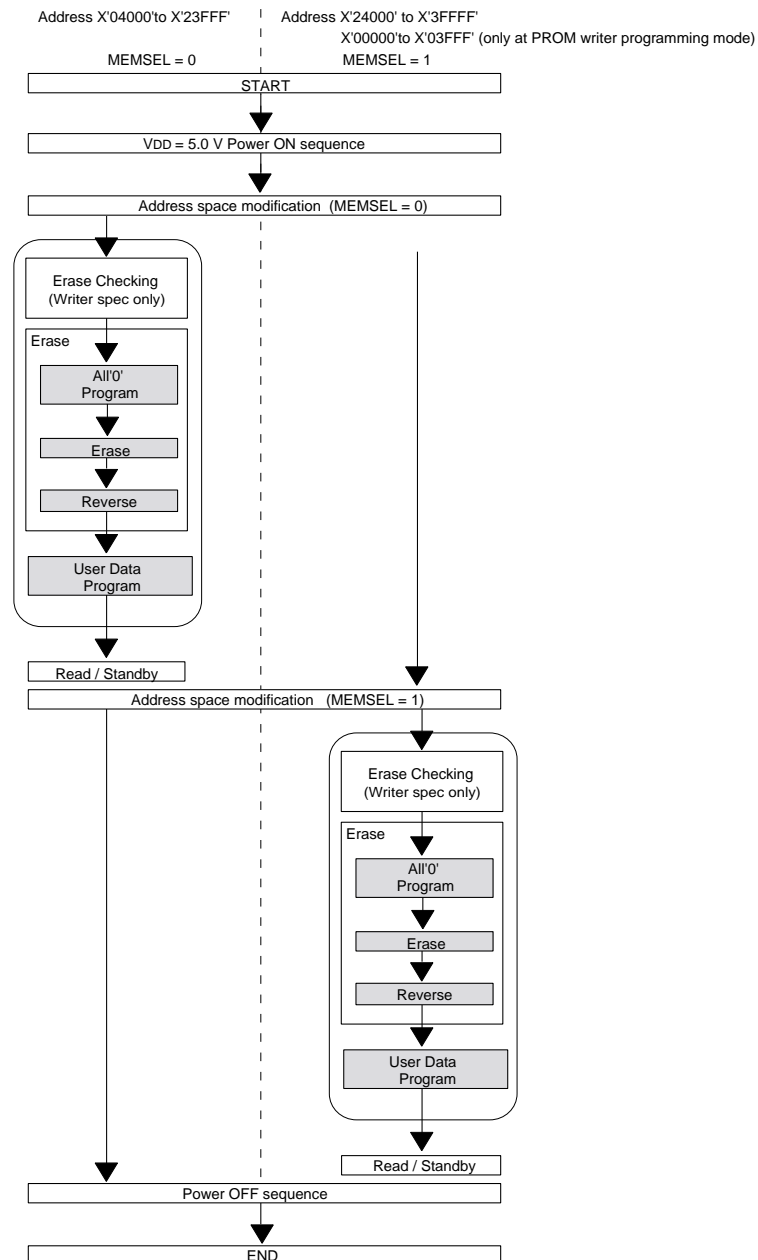


Figure 20-4-1 Reprogramming Flow of Internal Flash EEPROM

## 20-5 PROM writer mode

In PROM writer mode, the CPU is halted for Internal flash EEPROM to be programmed. The microcontroller is inserted into a dedicated adaptor socket, which connects to DATA-I/O's LabSite PROM writer. When the microcontroller connects to the adaptor socket, it automatically enters PROM writer mode.

■ Fixing a device in the adapter socket and the position of the No.1 pin.

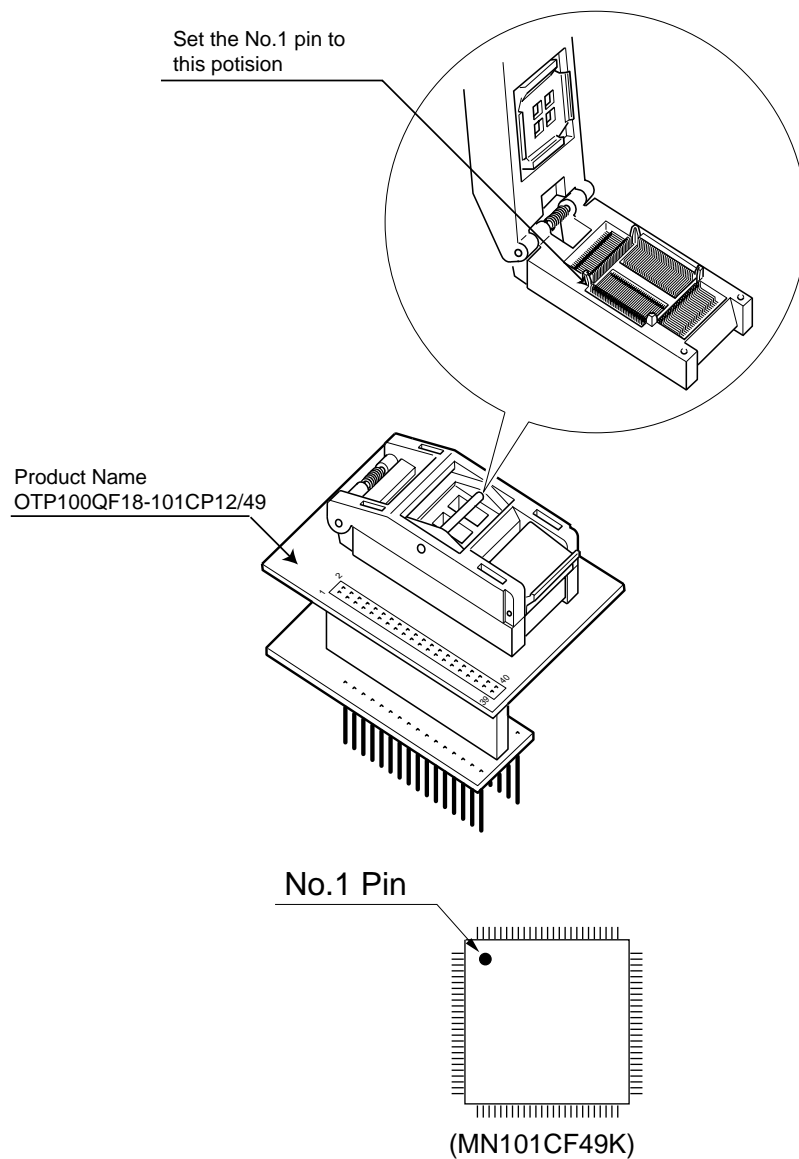
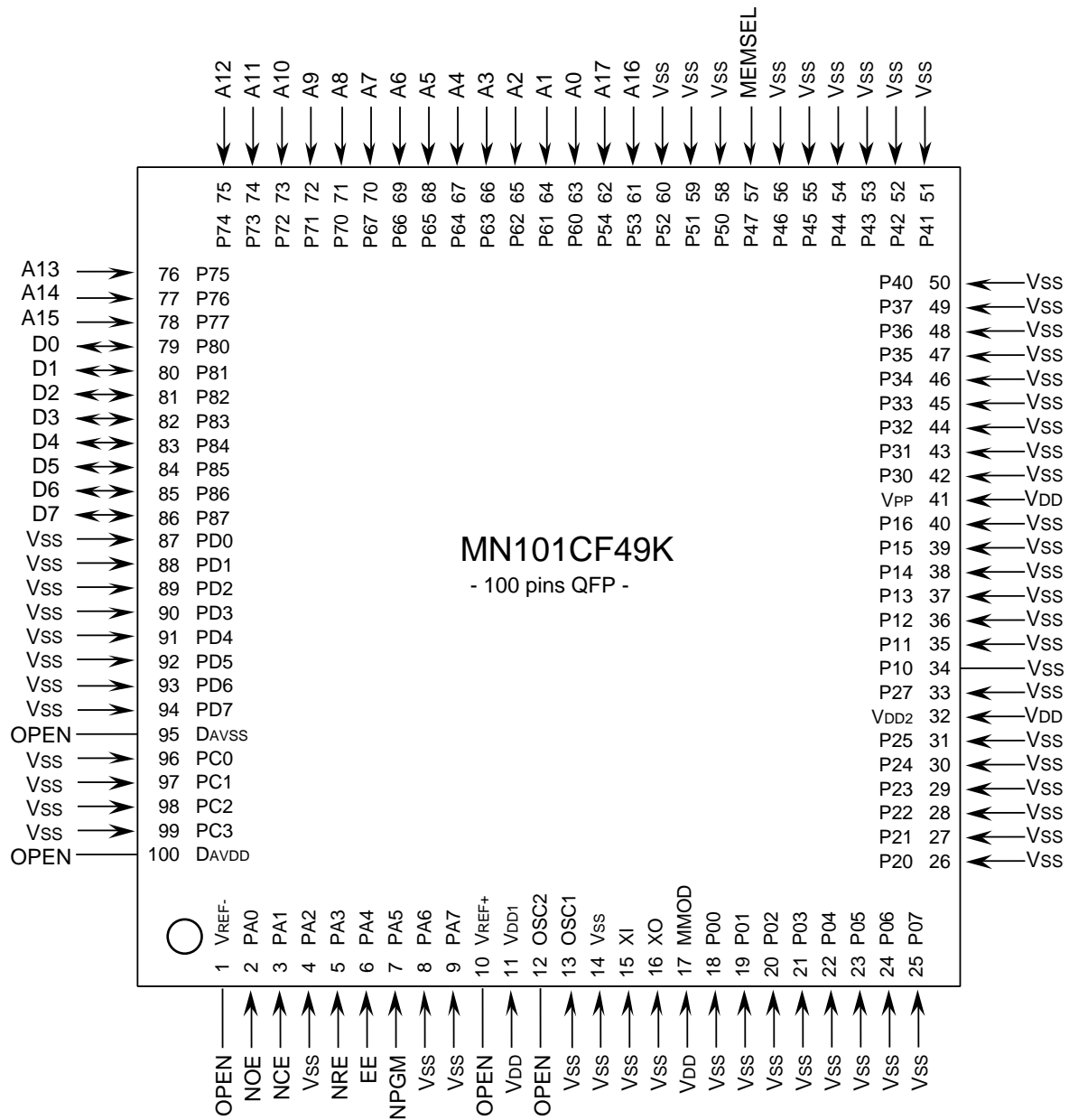


Figure 20-5-1 Fixing a Device on the Adapter Socket and the Position of No.1 Pin

■ Pin Configuration for Socket Adaptor



Package : QFP100-P-1818B  
Pin pitch : 0.65 mm

Figure 20-5-2 Pin Configuration for Socket Adaptor



Please refer to the pin configuration of 2M-bit EPROM (27C201).

## 20-6 Onboard Serial Programming Mode

### 20-6-1 Overview

The onboard serial programming mode is primarily used to program the flash EEPROM in devices that are already installed on a PCB board with internal serial interface. Use the dedicated serial writer (YDC MODEL: AF200) for programming controlled by the load program. In this mode, load program is write/erase-protected in the hardware.

#### ■Hardware and software requirements

Hardware and software products required for onboard serial programming are as follows.

##### Hardware requirements


- Onboard serial writer (YDC MODEL: AF200)
- Flash programming connectors or pins for target board.

##### Software requirements

- Load program installed in the internal flash EEPROM
- Programming algorithm for operating onboard serial writer

#### ■Built-in hardware for onboard serial programming mode

Use this LSI's serial interface 2 as a standard serial writer for programming the flash EEPROM in onboard serial programming mode.

[  Chapter 13 Serial Interface 2 ]



Serial interface I/O pins (SBT2, SBI2, SBOS) used for onboard serial programming should be reserved as dedicated pins to prevent other user circuits from communicating with the device. Alternatively, design your target board to be capable of normal communication with serial writer.

#### ■Onboard serial programming writer (YDC MODEL: AF200)

For further information of the onboard serial writer, contact :

YDC Corporation Instrument Business Division Support Center

Phone : 042-333-6245

<http://www.ydc.co.jp/micom>

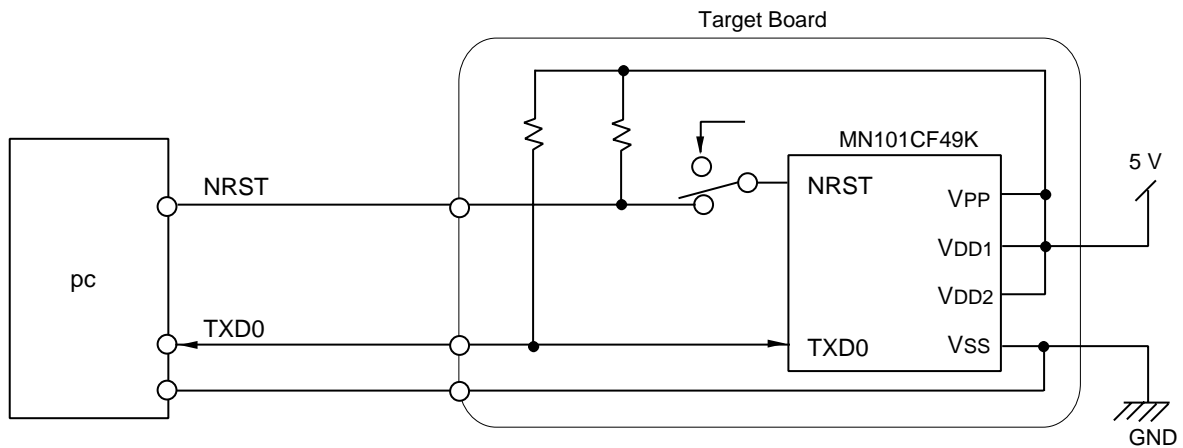
Model: AF200 flash microcontroller programmer



## 20-6-2 Circuit Requirements for the Target Board

This section describes the circuit requirements for the target board for onboard serial programming; first programming with the serial interface 0 UART communication using PC, next programming with the serial interface 2 clock synchronous communication using YDC serial writer.

### ■ Programming with the UART communication using PC



**Figure 20-6-1 Target Board for programming with the UART communication using PC**

#### Pins

VDD1 : 5.0 V power supply (for I/O)

VDD2 : 5.0 V Power supply (for flash EEPROM and internal circuits)

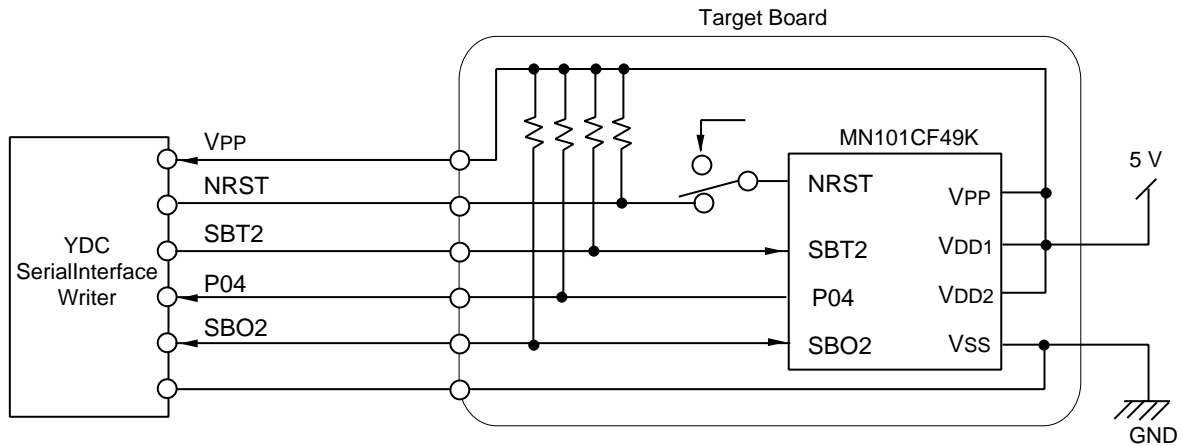
VPP : VPP level detection pin for target board

NRST: Reset

TXD0 : Serial interface 0 data I/O pin (used as P00/SB00 pin as well during UART communication)

GND : Ground

■ Programming with the clock synchronous communication using YDC serial writer



**Figure 20-6-2 Target Board for programming with the clock synchronous communication using Serial writer**

**Pins**

- VDD1 : 5.0 V power supply pin (for I/O)
- VDD2 : 5.0 V power supply pin (for flash EEPROM and internal circuits)
- VPP : VPP level detection pin for target board
- NRST: Reset
- SBO2: Serial interface 2 data I/O pin (used as P3 pin as well during clock synchronous communication)
- SBT2 : Serial interface 2 clock pin (used as P5 pin as well during clock synchronous communication)
- P04 : Busy signal output pin (used as SBI2 as well during clock synchronous communication)
- GND : Ground

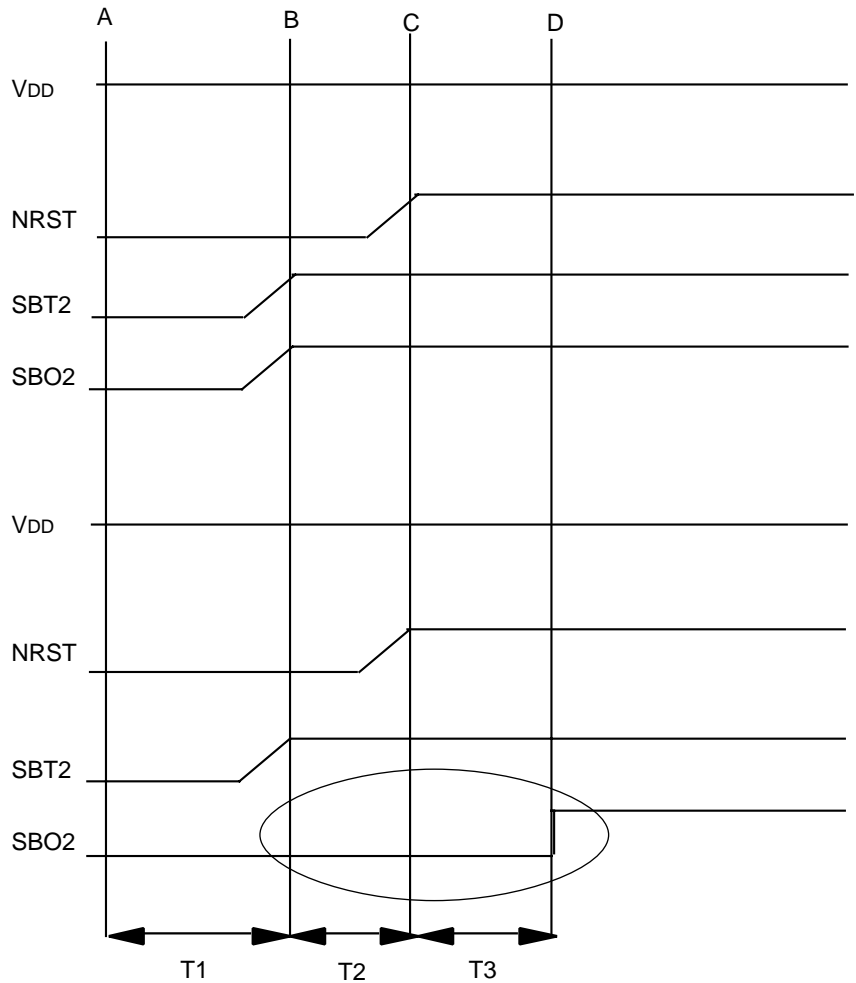
**Use of YDC serial writer**

- VDD1 and VDD2 pins must supply 5.0 V from external power source.
- When VPP level is too low, serial writer generates error message.
- Connect pull-up resistors on the target board to NRST, SBT2, P04 and SB02 pins, which are connected to the power supply.
- Install a switch on the target board to toggle between NRST for serial programming and NRST for normal operation. Alternatively, install a wired-OR connection. (For a wired-OR connection, disable NRST for normal operation during serial programming)
- NRST and SBT2 pins are output from the serial writer through an open connection.
- SBT2, P04 and SB02 pins should be reserved as dedicated pin for serial writer to prevent other user circuits on the target board from communicating with the device. Alternatively, design your target board on which the serial writer can program the device correctly.

### 20-6-3 On-board Programming Mode

To enter serial programming mode, the microcontroller must be in write mode. This section describes the pin setup for the serial writer interface.

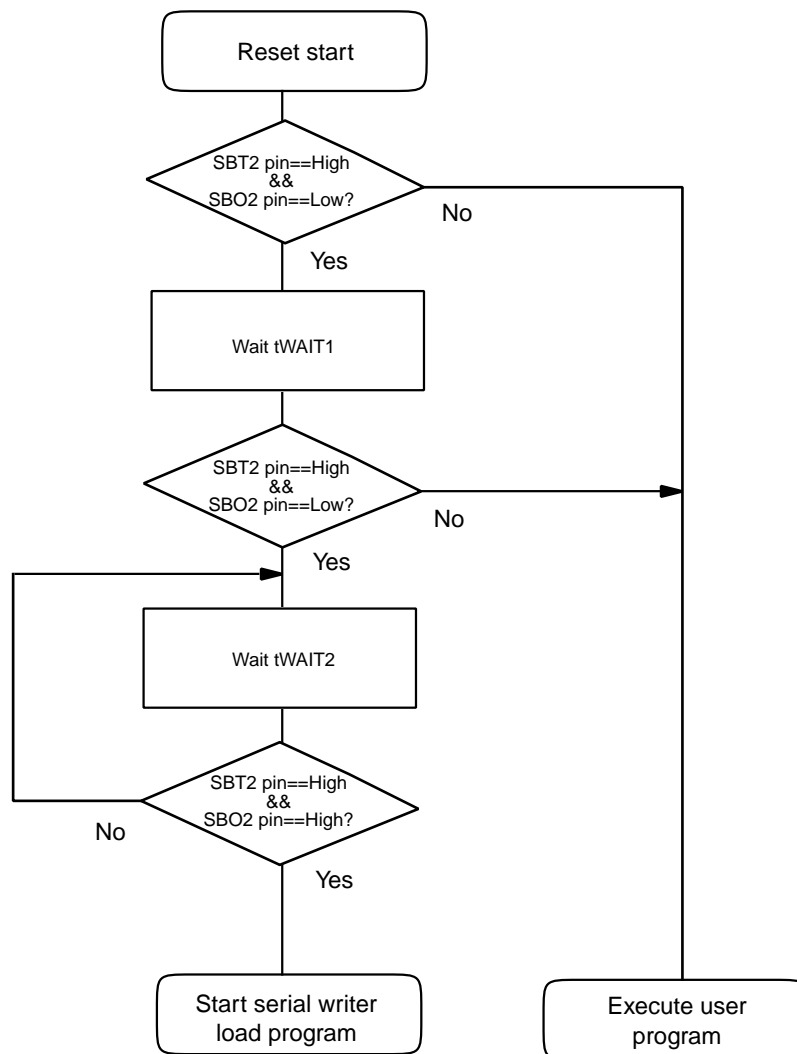
Normal timing waveform



Timing waveform during serial programming

- To set up the serial writer interface:
  1. Turn on the external V<sub>DD</sub> supply
  2. At timing A, serial interface writer outputs NRST=SBT2=Low.
  3. Through the serial writer, drive the NRST pin from timing B, when SBT2 goes high on microcontroller power-up, for T<sub>2</sub> cycles. The microcontroller initializes.
  4. Through the serial writer, drive the SBO0 pin Low from time C, when SBT2 goes high on microcontroller power-up, for T<sub>3</sub> cycles. This signals the microcontroller that it is connected to the serial writer.
  5. Make T<sub>3</sub> long enough to allow the microcontroller oscillator to stabilize.

● Start routine for the load program



Conditions:

- (1) After the load program initiates a reset start, SBO2 must be low and SBT2 high.
- (2) Wait t<sub>WAIT1</sub>.
- (3) SBO2 must be low and SBT2 high.
- (4) Within t<sub>WAIT2</sub>, both SBO2 and SBT2 must be high.

If any of these conditions is not met, control returns to the user program.

## 20-6-4 Memory Space

This section describes each memory space of built-in flash EEPROM.

•Serial writer load program area      x'040C0 to X'040C0+n'

This KB of ROM at address x'040C0' to n KB holds the load program for the serial writer.

The area is erase/write-protected in the hardware.

•Subroutine vector address area      x'04080' to x'040BF'

This area is unused in Load program.

The area is erase/write-protected by the software.

A parallel writer is necessary to use this space.

•Fixed user program area      x'040C0+n' to X'057FF'

The area is erase/write-protected by the software.

A parallel writer is necessary to store a fixed user program in this space.

•Branch instruction to reset service routine      x'05808'

Normally, reset servicing starts at address x'04000', but the soft branch instruction in the serial writer load program branches to x'05808'. This address must hold a JMP instruction pointing to the real start address for the reset service routine.

•Branch instruction to interrupt service routine

Normally, interrupt servicing starts at address x'04004', but the soft branch instruction in the serial writer load program branches to x'0580C'. This address must hold a JMP instruction pointing to the real start address for the interrupt service routine

```

x'04004'  ⇒  x'0580C'
          :
          :
x'04078'  ⇒  x'05880'

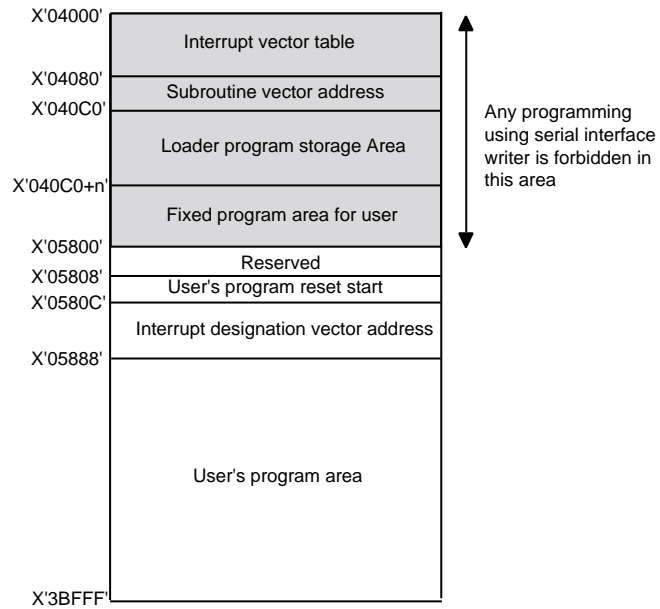
```

•User program area

This area stores the user program.

You can erase/write this area using either serial writer or Parallel writer.

Figure 20-6-3 shows the memory map of internal flash EEPROM.



**Figure 20-6-3 Internal Flash EEPROM Memory map**

# Record of Changes

MN101C49G/49H/49K/F49K/P49K LSI User's Manual Record of Changes (Ver.4.0 to Ver.4.1)

Line	Definition	Details of Changes	
		former version	new version
	Add	MN101C49G/49H/49K	MN101C49G/49H/49K/ <u>F49K/P49K</u>
18	Add	The package is a 100-pin QFP.	The packages are 100-pin QFP <u>and 100-pin LQFP.</u>
1 from the bottom	Add	—	100-pin LQFP (14 mm sqyare / 0.5 mm pitch) code name: LQFP100-p-1414
Fig.1-3-1	Add	Pin configuration (100QFP: TOP VIEW)	Pin configuration (100QFP/ <u>100LQFP</u> : TOP VIEW)
page	Add		Figure 1-6-2 100-pin LQFP
14	Add	—	(refer to the cautions on X1-48)

# Record of Changes

## MN101C49G/49H/49K LSI User's Manual Record of Changes (Ver.3 to Ver.4) 1/2

Page	Section	Definition	Details of Changes	
			Previous Edition (3rdEdition)	New Edition (4thEdition)
All Chapters	-	Change	MN101C00 Series	MN101C Series
-	-	Deletion	<p>■Where to Send Inquires We welcome your questions, comments, and suggestions. Please contact the semiconductor design center closest to you. See the last page of this manual for a list of addresses and telephone numbers.</p>	-
I-11	Table 1-3-3	Change	(Pin No.33 Input Reset pin) If a capacitor is to be inserted between NRST and VDD, it is recommended that a discharge diode be placed between NRST and VDD.	(Pin No.33 Input Reset pin) If a capacitor is to be inserted between NRST and VSS, it is recommended that a discharge diode be placed between NRST and VDD.
II-13, 14, 15	Caution	Addition	-	The value of internal RAM is uncertain when power is applied to it. It needs to be initialized before it is used.
II-32	Caution	Addition	-	When the memory bank function of the MN101C49 series, EPROM version is used in single-chip mode, set the EXWH, EXW1-0 flags of the memory control register (MEMCTR; x3F01') as follows; Set the EXWH (bit3) to "1" (Fixed wait mode) Set the EXW1-0 (bit1,0) to "00" (No wait mode)
II-44	Caution	Change	When NRST pin is connected to low power voltage circuit that .....	When NRST pin is connected to low power voltage <u>detection</u> circuit that .....
III-17	Caution	Addition	-	Cautions about interrupts generated by undefined instructions
III-49	Caution	Addition	-	Precautions for use of both edges interrupts
IV-4	Key mark	Addition	-	How to determine pull-up / pull-down resistor values
VI-35	Caution	Addition	-	When timer output is selected as serial interface 0, 2 or 3 transfer clock, select fosc as a clock source of the timer. If other clock is selected, normal transfer of serial interface data is not guaranteed.
XI-11 XI-16 XI-29 XI-35 XI-40 XI-47 XIII-8 XIII-12 XIII-26 XIV-9 XIV-12 XIV-26 XIV-40	Caution	Addition	-	When timer output is selected as serial interface transfer clock, select fosc as a clock source of the timer. If other clock is selected, normal transfer of serial interface data is not guaranteed.
VII-11	Caution	Addition	-	Cautions about write timing to 16-bit timer preset register
XI-33	Caution	Change	In case the SC0NPE flag is "1" and disable parity bit is selected, do not set character bit 7 bits + stop bit 2 bits of frame mode.	Do not set following frame modes when SC0NPE flag is "1" and parity bit is disabled, Character 7 bits + Stop 2 bits of the frame mode (Set the SC0FM1, SC0FM0 flags to "0, 1".) Character 7 bits + Stop 1 bit of the frame mode (Set the SC0FM1, SC0FM0 flags to "0, 0".)



MN101C49G/49H/49K LSI User's Manual Record of Changes (Ver.3 to Ver.4) 2/2

Page	Section	Definiti- on	Details of Changes	
			Previous Edition (3rdEdition)	New Edition (4thEdition)
XI-36	-	Addition	-	Description about transmission/reception bit number of 7-bit data and the first transfer bit in UART communication
XI-48	Caution	Addition	-	Cautions about full-duplex UART communication using serial interface 0
Chapter 17	-	Change	D/A2	D/A
XIX-25 to XIX-32	19-5 19-6	Change	19-5 Instruction Set (Ver.2.0) 19-6 Instruction Map (Ver2.0)	19-5 Instruction Set (Ver.3.2) 19-6 Instruction Map (Ver2.1)
Chapter 20	-	Addition	-	Chapter 20 Flash EEPROM

MN101C49G/49H/49K LSI User's Manual Record of Changes (Ver.1 to Ver.3)

Page	Line	Definition	Details of Changes	
			Previous Edition (1st Edition)	New Edition (3rd Edition)
Cover	-	Add	MN101C49G LSI User's Manual	MN101C49G/49H/49K LSI User's Manual
Chapter 1 Chapter 2	-	Add	-	Information of MN101C49G/49H
All Chapters	-	Change	-	Spellings Sentences
I - 3	8 10 12	Change	0.25 $\mu$ s / 8.39 MHz 0.12 $\mu$ s / 8.39 MHz 62.5 $\mu$ s / 32 kHz	0.238 $\mu$ s / 8.39 MHz 0.119 $\mu$ s / 8.39 MHz 61.04 $\mu$ s / 32.768 kHz
I - 19 to I - 29	-	Change Add Delete	1-5 Electrical Characteristics	1-5 Electrical Characteristics Minor Revision
II - 20	-	Add	-	Precautions and Warnings, Key Information
II - 25	-	Add	-	Key Information
III - 6	-	Add	-	Key Information
III - 8	-	Add	-	Key Information
III - 16	-	Add	-	Precautions and Warnings
III - 49	-	Add	-	Key Information
VI - 20	-	Add	-	Key Information
VI - 27	-	Add	-	Key Information
VII - 22	-	Add	-	Key Information
VIII - 7	-	Add	-	Sentences for Precautions and Warnings
XVI -13	-	Add	-	Key Information

**MN101C49G/49H/49K/F49K/P49K**  
**LSI User's Manual**

January, 2004 4th Edition 1st printing

Issued by Matsushita Electric Industrial Co., Ltd.

© Matsushita Electric Industrial Co., Ltd.

# Semiconductor Company, Matsushita Electric Industrial Co., Ltd.

Nagaokakyo, Kyoto 617-8520, Japan

Tel: (075) 951-8151

<http://panasonic.co.jp/semicon>

## SALES OFFICES

### ■ NORTH AMERICA

#### ●U.S.A. Sales Office:

**Panasonic Industrial Company** [PIC]

##### • New Jersey Office:

2 Panasonic Way Secaucus, New Jersey 07094 U.S.A.  
Tel: 1-201-348-5257 Fax:1-201-392-4652

##### • Chicago Office:

1707 N. Randall Road Elgin, Illinois 60123-7847 U.S.A.  
Tel: 1-847-468-5720 Fax:1-847-468-5725

##### • San Jose Office:

2033 Gateway Place, Suite 200  
San Jose, California 95110 U.S.A.  
Tel: 1-408-487-9510 Fax:1-408-436-8037

##### • Atlanta Office:

1225 Northbrook Parkway Suite 1-151 Suwanee, GA  
30024 U.S.A.  
Tel: 1-770-338-6953 Fax:1-770-338-6849

##### • San Diego Office:

9444 Balboa Avenue, Suite 185, San Diego, California  
92123 U.S.A.  
Tel: 1-858-503-2910 Fax:1-858-715-5545

#### ●Canada Sales Office:

**Panasonic Canada Inc.** [PCI]

5770 Ambler Drive 27 Mississauga, Ontario, L4W 2T3  
CANADA  
Tel: 1-905-238-2243 Fax:1-905-238-2414

### ■ LATIN AMERICA

#### ●Mexico Sales Office:

**Panasonic de Mexico, S.A. de C.V.** [PANAMEX]

Amores 1120 Col. Del Valle Delegacion Benito Juarez  
C.P. 03100 Mexico, D.F. MEXICO  
Tel: 52-5-488-1000 Fax:52-5-488-1073

##### • Guadalajara Office:

SUCURSAL GUADALAJARA  
Av. Lazaro Cardenas 2305 Local G-102 Plaza Comercial  
Abastos; Col. Las Torres Guadalajara, Jal. 44920  
MEXICO  
Tel: 52-3-671-1205 Fax:52-3-671-1256

#### ●Brazil Sales Office:

**Panasonic do Brasil Ltda.** [PANABRAS]

Caixa Postal 1641, Sao Jose dos Campos, Estado de Sao  
Paulo, BRASIL  
Tel: 55-12-3935-9000 Fax:55-12-3931-3789

### ■ EUROPE

#### ●Europe Sales Office:

**Panasonic Industrial Europe GmbH** [PIE]

##### • U.K. Sales Office:

Willoughby Road, Bracknell, Berks., RG12 8FP,  
THE UNITED KINGDOM  
Tel: 44-1344-85-3671 Fax:44-1344-85-3853

##### • Germany Sales Office:

Hans-Pinsel-Strasse 2 85540 Haar, GERMANY  
Tel: 49-89-46159-119 Fax:49-89-46159-195

### ■ ASIA

#### ●Singapore Sales Office:

**Panasonic Semiconductor of South Asia** [PSSA]

300 Beach Road, #16-01, The Concourse, Singapore  
199555 THE REPUBLIC OF SINGAPORE  
Tel: 65-6390-3688 Fax:65-6390-3689

#### ●Malaysia Sales Office:

**Panasonic Industrial Company (M) Sdn. Bhd.** [PICM]

##### • Head Office:

15th floor, Menara IGB, Mid Valley City, Lingkaran Syed  
Putra, 59200 Kuala Lumpur, MALAYSIA  
Tel: 60-3-2297-6888 Fax:60-3-2284-6898

##### • Penang Office:

Suite 20-07,20th Floor, MWE Plaza, No.8, Lebuhr  
Farquhar,10200 Penang, MALAYSIA  
Tel: 60-4-201-5113 Fax:60-4-261-9989

##### • Johore Sales Office:

Menara Pelangi, Suite8.3A, Level8, No.2, Jalan Kuning  
Taman Pelangi, 80400 Johor Bahru, Johor, MALAYSIA  
Tel: 60-7-331-3822 Fax:60-7-355-3996

#### ●Thailand Sales Office:

**Panasonic Industrial (THAILAND) Ltd.** [PICT]

252-133 Muang Thai-Phatra Complex Building, 31st Fl.  
Rachadaphisek Rd., Huaykwang, Bangkok 10320,  
THAILAND  
Tel: 66-2-693-3400~21 Fax:66-2-693-3422~27

#### ●Philippines Sales Office:

**Panasonic Industrial Sales Philippines** [PISP]

102 Laguna Boulevard,Bo. Don Jose Laguna Technopark,  
Santa Rosa, Laguna 4026 THE PHILIPPINES  
Tel: 63-2-520-8615 Fax:63-2-520-8629

#### ●China Sales Office:

**Panasonic Industrial (Shanghai) Co., Ltd.** [PI(SH)]

Floor 12, China Insurance Building, 166 East Road  
LuJiaZui, PuDong New District, Shanghai, 200120 CHINA  
Tel: 86-21-6841-9642 Fax:86-21-6841-9631

**Panasonic Industrial (Tianjin) Co., Ltd.** [PI(TJ)]

Room No.1001, Tianjin International Building 75, Nanjin  
Road, Tianjin 300050, CHINA  
Tel: 86-22-2313-9771 Fax:86-22-2313-9770

**Panasonic SH Industrial Sales (Shenzhen) Co., Ltd.**

[PSI(SZ)]

##### • Shum Yip Centre Office:

25F, Shum Yip Centre, #5045, East Shennan Road,  
Shenzhen, CHINA  
Tel: 86-755-8211-0888 Fax:86-755-8211-0970

**Panasonic Shun Hing Industrial Sales (Hong Kong)**

**Co., Ltd.** [PSI(HK)]

11th Floor, Great Eagle Center 23 Harbour Road,  
Wanchai, HONG KONG  
Tel: 852-2529-7322 Fax:852-2865-3697

#### ●Taiwan Sales Office:

**Panasonic Industrial Sales (Taiwan) Co.,Ltd.** [PIST]

##### • Head Office:

6F, 550, Sec. 4, Chung Hsiao E. RD. Taipei, 110, TAIWAN  
Tel: 886-2-2757-1900 Fax:886-2-2757-1906

##### • Kaohsiung Office:

6th Floor, Hsin Kong Bldg. No.251, Chi Hsien 1st Road  
Kaohsiung 800, TAIWAN  
Tel: 886-7-346-3815 Fax:886-7-236-8362

#### ●Korea Sales Office:

**Panasonic Industrial Korea Co., Ltd.** [PIKL]

Kukje Center Bldg. 11th Fl., 191 Hangangro 2ga,  
Youngsan-ku, Seoul 140-702, KOREA  
Tel: 82-2-795-9600 Fax:82-2-795-1542