

MN3000 Series

HIGH-ACCURACY
8-Bit D/A CONVERTERS

FEATURES

- Complete D/A Converters: Internal Reference Internal Output Op Amp
- Small 14-Pin DIP
- $\pm 1/2$ LSB Linearity and Monotonicity Guaranteed Over Temperature
- $\pm 1/4$ LSB Zero Error Over Temperature
- ± 1 LSB Absolute Accuracy Over Temperature
- Adjustment-Free
- Full Mil Operation -55°C to $+125^{\circ}\text{C}$
- MIL-H-38534 Screening Optional. MIL-STD-1772 Qualified Facility

DESCRIPTION

The MN3000 Series are 8-bit, voltage-output, digital-to-analog converters that offer high accuracies, particularly around zero, and adjustment-free operation. Each unit contains an internal reference and output amplifier and is packaged in a 14-pin, ceramic, hermetically sealed dual-in-line package.

Units are available for either 0°C to $+70^{\circ}\text{C}$ or -55°C to $+125^{\circ}\text{C}$ ("H" models) operation. Functional laser trimming of our own ultra-stable thin-film resistor networks eliminates the need for gain and offset adjustments and allows us to guarantee the following over the entire operating temperature range: $\pm 1/2$ LSB linearity error, $\pm 1/4$ LSB zero error and ± 1 LSB unadjusted full scale absolute accuracy error.

Four output voltage ranges are available (MN3000, 0 to -10V ; MN3001, $\pm 5\text{V}$; MN3002, 0 to $+10\text{V}$; MN3006, $\pm 10\text{V}$), and all devices operate from $\pm 15\text{V}$ supplies consuming a maximum of 660mW. For military/aerospace or harsh-environment commercial/industrial applications, "H/B CH" models are fully screened to MIL-H-38534 in Micro Networks MIL-STD-1772 qualified facility.

MN3000 Series D/A's are excellent choices for servo and other applications requiring high accuracy and repeatability around zero. In many cases, their excellent accuracies allow them to be used as cost-saving replacements for higher-resolution converters. Their completeness, small size, low weight, guaranteed accuracy and thin-film reliability make them excellent choices for military and aerospace applications.

14 PIN DIP

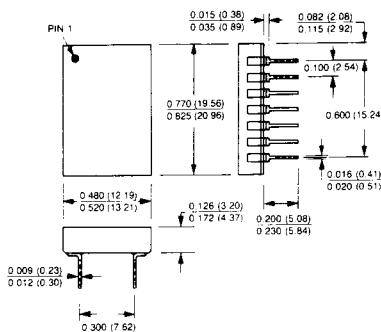

Dimensions in Inches
(millimeters)



MICRO NETWORKS

324 Clark St., Worcester, MA 01606 (508) 852-5400

May 1988

MN3000

www.DataSheet4U.com

MN3000 SERIES HIGH-ACCURACY 8-Bit D/A CONVERTERS

ORDERING INFORMATION

PART NUMBER _____ MN300XH/B/CH

Select model (MN3000, MN3001, etc.) _____

Standard Part is specified for 0°C to +70°C operation.

Add "H" suffix for specified -55°C to +125°C operation.

Add "B" to "H" devices for Environmental Stress Screening.

Add "CH" to "H/B" devices for 100% screening according to MIL-H-38534.

ABSOLUTE MAXIMUM RATINGS:

Operating Temperature	0°C to +70°C -55°C to +125°C ("H" Models)
Storage Temperature	-65°C to +150°C
+15V Supply (Pin 9)	+18 Volts
-15V Supply (Pin 7)	-18 Volts
Digital Inputs (Pins 1-4, 11-14)	-0.5 to +15 Volts

SPECIFICATIONS ($T_A = 25^\circ\text{C}$, Supply Voltages +15V, unless otherwise specified).

DIGITAL INPUTS	MIN.	TYP.	MAX.	UNITS
Logic Levels: Logic "1" Logic "0"	2.0		0.8	Volts Volts
Input Currents: Logic "1" Logic "0"			40 -1	μA mA
ANALOG OUTPUTS				
Output Voltage Range: MN3000 MN3001 MN3002 MN3006		0 to -10 -5 to +5 0 to +10 -10 to +10		Volts Volts Volts Volts
Output Impedance Output Current	± 4	0.5		Ohms mA
TRANSFER CHARACTERISTICS				
Linearity Error (Note 1): 0°C to +70°C -55°C to +125°C		$\pm \frac{1}{4}$	$\pm \frac{1}{2}$ $\pm \frac{1}{2}$	LSB LSB
Monotonicity	Guaranteed Over Temperature			
Full Scale Absolute Accuracy Error (Notes 2, 3): +25°C -55°C to +125°C (Note 4)		$\pm \frac{1}{4}$	$\pm \frac{1}{2}$ ± 1	LSB LSB
Zero Error (Notes 2, 3): +25°C -55°C to +125°C (Note 4)		$\pm \frac{1}{8}$	$\pm \frac{1}{4}$ $\pm \frac{1}{4}$	LSB LSB
Unipolar Offset Error (Notes 2, 3) MN3000: +25°C -55°C to +125°C (Note 4) MN3002: +25°C -55°C to +125°C (Note 4)		$\pm \frac{1}{4}$ $\pm \frac{1}{8}$	$\pm \frac{1}{2}$ ± 1 $\pm \frac{1}{4}$ $\pm \frac{1}{4}$	LSB LSB LSB LSB
Bipolar Offset Error (Notes 2, 3) MN3001, MN3006: +25°C -55°C to +125°C (Note 4)		$\pm \frac{1}{4}$	$\pm \frac{1}{2}$ ± 1	LSB LSB
Offset Drift: MN3002 MN3000, MN3001, MN3006		± 2 ± 10		ppm of FSR/ $^\circ\text{C}$ ppm of FSR/ $^\circ\text{C}$
Gain Error (Note 2) Gain Drift		± 0.1 ± 20		% ppm/ $^\circ\text{C}$
DYNAMIC CHARACTERISTICS				
Settling Time: 10V Step to $\pm 1/2$ LSB 20V Step to $\pm 1/2$ LSB Output Slew Rate		23 46 0.5	30 60	μSec μSec Volts/ μSec
POWER SUPPLY REQUIREMENTS				
Power Supply Range: +15V Supply -15V Supply	+14.55 -14.55	+15.00 -15.00	+15.45 -15.45	Volts Volts
Power Supply Rejection (Note 5): +15V Supply -15V Supply		± 0.01 ± 0.015		% FSR / % Vs % FSR / % Vs
Current Drain, Output Unloaded (Note 6): +15V Supply -15V Supply		17 -17	22 -22	mA mA
Power Consumption		510	660	mW

SPECIFICATION NOTES:

- Micro Networks tests and guarantees maximum Linearity Error at room temperature and at both extremes of the specified operating temperature range.
- See the Absolute Accuracy Error section on Page 3 for an explanation of how Micro Networks Corporation tests and specifies Full Scale Absolute Accuracy, Zero, Offset, and Gain Errors.
- One LSB for an 8 bit converter corresponds to 0.39% FSR. FSR stands for Full Scale Range and is equal to the peak to peak voltage of the converter's

output range. For the MN3006, FSR is equal to 20V and 1 LSB is equal to 78mV. For the MN3000, MN3001, and MN3002, FSR is equal to 10V and 1 LSB is equal to 39mV.

- For Commercial Models, this specification applies over the 0°C to +70°C temperature range. See Ordering Information.
- The MN3000 Series will operate over a power supply range of +14V to ± 18 V with reduced accuracy.

BLOCK DIAGRAM

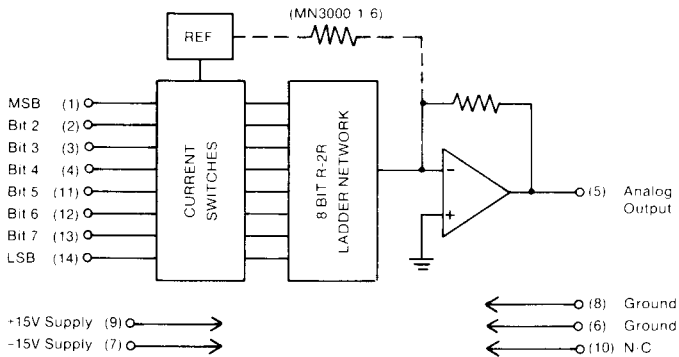

PIN DESIGNATIONS

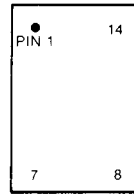

- | | |
|-----------------|----------------|
| 1 Bit 1 (MSB) | 14 Bit 8 (LSB) |
| 2 Bit 2 | 13 Bit 7 |
| 3 Bit 3 | 12 Bit 6 |
| 4 Bit 4 | 11 Bit 5 |
| 5 Analog Output | 10 N/C |
| 6 Ground | 9 +15V Supply |
| 7 -15V Supply | 8 Ground |

ABSOLUTE ACCURACY ERROR

The Absolute Accuracy Error of a voltage output D/A converter is the difference between the actual, unadjusted, output voltage that appears following the application of a given digital input code and the ideal or expected output voltage for that code. This difference is usually expressed in LSB's or %FSR (see Note 3 above). Absolute Accuracy Error includes gain, offset, linearity, and noise errors and encompasses the drifts of these errors when specified over temperature.

For the MN3000 Series converters with unipolar output ranges (MN3000, MN3002), Micro Networks tests Absolute Accuracy Error at the zero and full scale outputs. For the units with bipolar output ranges (MN3001, MN3006), we test both the positive and negative full scale outputs as well as the zero volt output. We perform these tests at +25°C and at the high and low extremes of the specified operating temperature range. The errors appear in the specification table as the Full Scale Absolute Accuracy and Zero Errors.

EXAMPLE: For the MN3006H ($\pm 10V$ output range, $-55^\circ C$ to $+125^\circ C$), the expected output for a 0000 0000 digital input is $-9.922V$, the expected output for a 0111 1111 digital input is $0V$, and the expected output for a 1111 1111 digital input is $+10.000V$. Micro Networks measures all three actual, unadjusted, output voltages at $+25^\circ C$, $-55^\circ C$, and $+125^\circ C$. We guarantee that when the digital input is all "1's" or all "0's", the output will be at its ideal positive or negative full scale value $\pm 39mV$ ($\pm 1/2$ LSB) at $+25^\circ C$ and $\pm 78mV$ (± 1 LSB) at $-55^\circ C$ and $+125^\circ C$. We guarantee that when the digital input is 0111 1111, the output will be zero volts $\pm 20mV$ ($\pm 1/4$ LSB) over the entire $-55^\circ C$ to $+125^\circ C$ temperature range. These limits are summarized in the two sketches below where the MN3006 digital input/analog output transfer function is shown as a dotted line, and the Absolute Accuracy limits are indicated with closed lines.

Unipolar and Bipolar Offset Error are both Absolute Accuracy Errors. Their definitions differ with respect to where along the converter's digital-input/analog-output transfer function the errors are to be measured, i.e., different analog output errors are measured at different digital input codes.

OFFSET ERROR — For the MN3000 Series, Offset Error is the Absolute Accuracy Error measured when the digital input is 0000 0000. For the MN3002, Offset Error tells how accurate the converter will be when its output is supposed to be zero volts. For this converter, Offset Error is the same

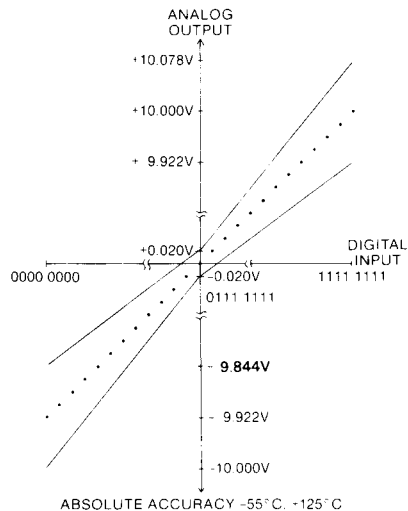
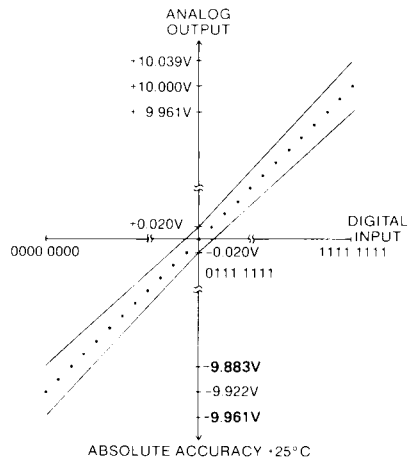

MN3000

as Zero Error discussed above. For the MN3000, MN3001, and MN3006, Offset Error tells how accurate the converters will be when their outputs are supposed to be at their minus full scale values. For these converters, Offset Error is equivalent to Full Scale Absolute Accuracy Error.

It is redundant to specify Bipolar and Unipolar Offset Errors after giving Full Scale Absolute Accuracy and Zero Errors as described above. We have provided the offset specifications to simplify comparing the MN3000 Series to other 8 bit D/A's. Be sure you clearly understand each manufacturer's specification definitions before you compare converters solely on a data sheet basis.

GAIN ERROR — Gain Error is the difference between the ideal and the measured values of a converter's full scale range (minus 1 LSB). See Note 3 above. It is a measure of the slope of the converter's transfer function. Gain Error is not a type of Absolute Accuracy Error, but it can be calculated using two Absolute Accuracy Error measurements. It is equivalent to the Absolute Accuracy Error measured for the 1111 1111 digital input minus that measured for the 0000 0000 digital input, and it is usually expressed as a percentage.

See the Converter Tutorial Section of the Micro Networks' Product Catalogue for a complete discussion of converter specifications.

APPLICATIONS INFORMATION

LAYOUT CONSIDERATIONS — Proper attention to layout and decoupling is necessary to obtain specified accuracies from the MN3000 Series. The units' two Ground pins (Pins 6 and 8) should be tied together as close to the unit as possible and both connected to system analog ground, preferably through a large analog ground plane beneath the

package. If the grounds cannot be tied together and must be run separately, a non-polarized $0.01\mu\text{F}$ bypass capacitor should be connected between pins 6 and 8, as close to the package as possible and wide conductor runs employed.

Power supplies should be decoupled with tantalum or electrolytic type capacitors located as close to the MN3000 as possible. For optimum performance and noise rejection, $1\mu\text{F}$ capacitors paralleled with $0.01\mu\text{F}$ ceramic capacitors should be used as shown in the diagram below.

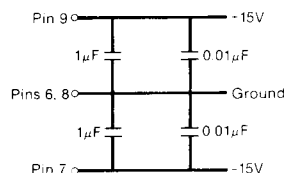

DIGITAL INPUT CODING

DIGITAL INPUT		ANALOG OUTPUT (DC VOLTS)			
MSB	LSB	MN3000	MN3001	MN3002	MN3006
1111	1111	0.000	+5.000	+9.961	+10.000
1111	1110	-0.039	+4.961	+9.922	+9.922
1000	0000	-4.961	+0.039	+5.000	-0.078
0111	1111	-5.000	0.000	+4.961	0.000
0000	0001	-9.922	-4.922	+0.039	-9.844
0000	0000	-9.961	-4.961	0.000	-9.922



MICRO NETWORKS

324 Clark St., Worcester, MA 01606 (508) 852-5400