

# MN4001B / MN4001BS

## Quad 2-Input NOR Gates

### ■ Description

The MN4001B/S are positive 2-input NOR gates and have 4 circuits in a package.

The outputs are fully buffered to improve the propagation characteristics between the input and output which are affected by increasing load capacitance and minimizes propagation delay time.

The MN4001B/S are equivalent to MOTOROLA MC14001B and RCA CD4001B.

### ■ Schematic Diagram (1/4)

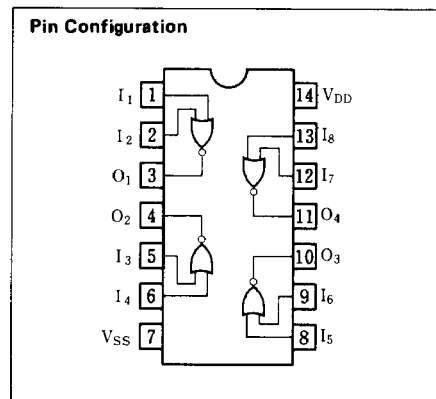
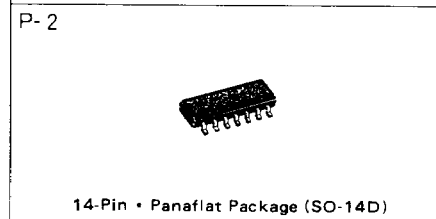
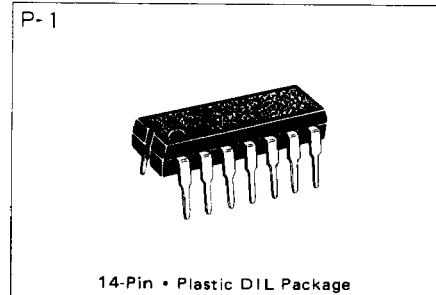
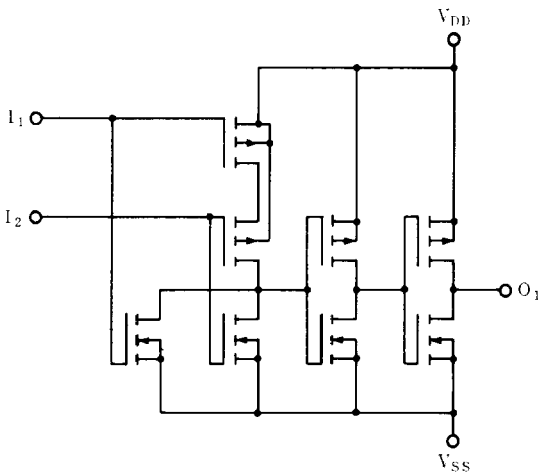

### ■ Maximum Ratings (Ta=25°C)

Item	Symbol	Ratings	Unit
Supply Voltage	V <sub>DD</sub>	-0.5 ~ +18	V
Input Voltage	V <sub>I</sub>	-0.5 ~ V <sub>DD</sub> +0.5*	V
Output Voltage	V <sub>O</sub>	-0.5 ~ V <sub>DD</sub> +0.5*	V
Peak Input · Output Current	± I <sub>I</sub>	max. 10	mA
Power Dissipation (per package)	T <sub>a</sub> = -40 ~ +60°C	max. 400	mW
	T <sub>a</sub> = +60 ~ +85°C	Decrease up to 200mW rating at 8mW/°C	
Power Dissipation (per output terminal)	P <sub>D</sub>	max. 100	mW
Operating Ambient Temperature	T <sub>opr</sub>	-40 ~ +85	°C
Storage Temperature	T <sub>stg</sub>	-65 ~ +150	°C

\* V<sub>DD</sub> + 0.5V should be under 18V

■ DC Characteristics (V<sub>SS</sub>=0V)

Item	V <sub>DD</sub> (V)	Symbol	Conditions	Ta=-40°C		Ta=25°C		Ta=85°C		Unit
				min.	max.	min.	max.	min.	max.	
Quiescent Power Supply Current	5	I <sub>DD</sub>	V <sub>I</sub> =V <sub>SS</sub> or V <sub>DD</sub>	—	1	—	1	—	7.5	μA
	10			—	2	—	2	—	15	
	15			—	4	—	4	—	30	
Output Voltage Low Level	5	V <sub>OL</sub>	V <sub>I</sub> =V <sub>SS</sub> or V <sub>DD</sub>  I <sub>O</sub>  <1μA	—	0.05	—	0.05	—	0.05	V
	10			—	0.05	—	0.05	—	0.05	
	15			—	0.05	—	0.05	—	0.05	
Output Voltage High Level	5	V <sub>OH</sub>	V <sub>I</sub> =V <sub>SS</sub> or V <sub>DD</sub>  I <sub>O</sub>  <1μA	4.95	—	4.95	—	4.95	—	V
	10			9.95	—	9.95	—	9.95	—	
	15			14.95	—	14.95	—	14.95	—	
Input Voltage Low Level	5	V <sub>IL</sub>	I <sub>O</sub>  <1μA V <sub>O</sub> =0.5V or 4.5V	—	1.5	—	1.5	—	1.5	V
	10			—	3	—	3	—	3	
	15			—	4	—	4	—	4	
Input Voltage High Level	5	V <sub>IH</sub>	I <sub>O</sub>  <1μA V <sub>O</sub> =0.5V or 4.5V	3.5	—	3.5	—	3.5	—	V
	10			7	—	7	—	7	—	
	15			11	—	11	—	11	—	
Output Current Low Level	5	I <sub>OL</sub>	V <sub>O</sub> =0.4V, V <sub>I</sub> =0V or 5V V <sub>O</sub> =0.5V, V <sub>I</sub> =0V or 10V V <sub>O</sub> =1.5V, V <sub>I</sub> =0V or 15V	0.52	—	0.44	—	0.36	—	mA
	10			1.3	—	1.1	—	0.9	—	
	15			3.6	—	3	—	2.4	—	
Output Current High Level	5	-I <sub>OH</sub>	V <sub>O</sub> =4.6V, V <sub>I</sub> =0V or 5V V <sub>O</sub> =9.5V, V <sub>I</sub> =0V or 10V V <sub>O</sub> =13.5V, V <sub>I</sub> =0V or 15V	0.52	—	0.44	—	0.36	—	mA
	10			1.3	—	1.1	—	0.9	—	
	15			3.6	—	3	—	2.4	—	
Output Current High Level	5	-I <sub>OH</sub>	V <sub>O</sub> =2.5V, V <sub>I</sub> =0V or 5V	1.7	—	1.4	—	1.1	—	mA
Input Leakage Current	15	±I <sub>I</sub>	V <sub>I</sub> =0V or 15V	—	0.3	—	0.3	—	1	μA

■ Switching Characteristics (Ta=25°C, V<sub>SS</sub>=0V, C<sub>L</sub>=50pF)

Item	V <sub>DD</sub> (V)	Symbol	min.	typ.	max.	Unit
Output Rise Time	5	t <sub>TLH</sub>	—	60	180	ns
	10		—	30	90	
	15		—	20	60	
Output Fall Time	5	t <sub>THL</sub>	—	60	180	ns
	10		—	30	90	
	15		—	20	60	
Propagation Delay Time	5	t <sub>PLH</sub>	—	50	150	ns
	10		—	25	75	
	15		—	20	60	
Propagation Delay Time	5	t <sub>PHL</sub>	—	60	180	ns
	10		—	25	75	
	15		—	20	60	
Input Capacitance		C <sub>I</sub>	—	—	7.5	pF

1. Switching Time Test Circuit

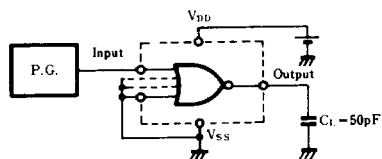

2. Waveforms

