

FEATURES

- 4.6V to 20V operating input range
- 3A output current
- Up to 94% efficiency
- High efficiency (>85%) at light load
- Adjustable Soft-Start
- Fixed 340kHz Switching frequency
- Input under voltage lockout
- Available in ESOP8 package
- Start-up current run-away protection
- Short circuit protection
- Thermal protection

APPLICATIONS

- Distributed Power Systems
- Networking Systems
- FPGA, DSP, ASIC Power Supplies
- Green Electronics/ Appliances
- Notebook Computers

DESCRIPTION

The MP1484 is a current mode monolithic buck switching regulator. Operating with an input range of 4.6-20V, the MP1484 delivers 3A of continuous output current with two integrated N-Channel MOSFETs. The internal synchronous power switches provide high efficiency without the use of an external Schottky diode. At light loads, regulators operate in low frequency to maintain high efficiency and low output ripple. Current mode control provides tight load transient response and cycle-by-cycle current limit.

The MP1484 guarantees robustness with short-circuit protection, thermal protection, start-up current run-away protection, and input under voltage lockout.

The MP1484 is available in an 8-pin ESOP package, which provides a compact solution with minimal external components.

TYPICAL APPLICATION

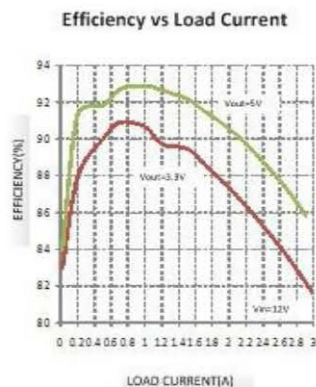
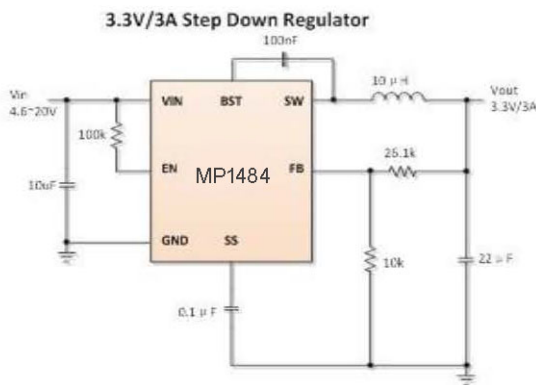

ORDERING INFORMATION

PART MARKING	PACKAGE DESCRIPTION	Top Marking	Package Form
MP1484	ESOP8	MP1484	Tape and reel packaging: 2500 pieces/tape IC tube: 100 pieces/tube

PIN CONFIGURATION

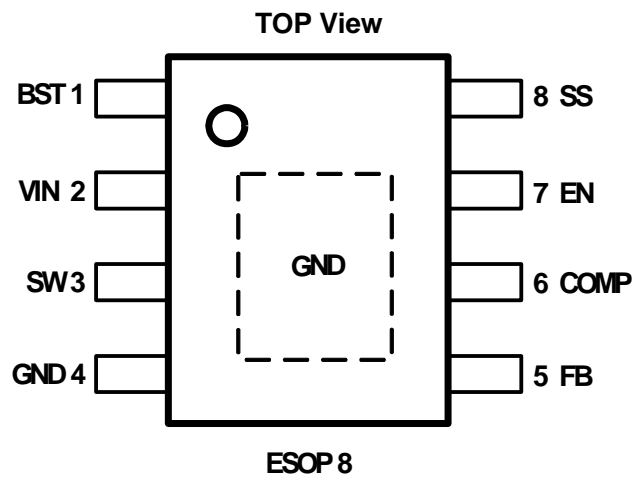

ABSOLUTE MAXIMUM RATING ¹⁾

VIN, EN, SW PIN	-0.3V to 22V
BST PIN	SW-0.3V to SW+5V
All other pins	-0.3V to 6V
Junction Temperature ²⁾³⁾	150°C
Lead Temperature	260 °C
Storage Temperature	-65 °C to +150 °C

RECOMMEND OPERATING RANGE

Input Voltage VIN	4.6V to 20V
Output voltage VOUT	0.8V to 17V
Operating Junction Temperature	-40°C ~125°C

THERMAL RESISTANCE θ_{JA} θ_{JC}

ESOP8	50	10	°C/W
-------	----	----	------

Note :

1) Exceeding these ratings may damage the device.
2) The MP1484 guarantees robust performance from -40°C to 150°C junction temperature. The junction temperature range specification is assured by design, characterization and correlation with statistical process controls.

3) The MP1484 includes thermal protection that is intended to protect the device in overload conditions. Thermal protection is active when junction temperature exceeds the maximum operating junction temperature. Continuous operation over the specified absolute maximum operating junction temperature may damage the device.

4) Measured on JESD51-7, 4-layer PCB.

ELECTRICAL

CHARACTERISTICS

V_{IN}=12V, T_A=25°C, unless otherwise stated.

Item	Symbol	Condition	Min.	Typ.	Max.	Units
V _{IN} Undervoltage Lockout Thershold	V _{IN_MIN}	V _{IN} falling		3.6		V
V _{IN} Undervoltage Lockout Hysteresis	V _{IN_MIN_HYST}	V _{IN} rising		650		mV
Shutdown Supply Current	I _{SD}	V _{EN} =0V			1	μA
Supply Current	I _Q	V _{EN} =5V, V _{FB} =2V		55		μA
Feedback Voltage	V _{FB}	4.6V<V _{IN} <20V		0.923		V
Error Amplifier Transconductance	G _{EA}	V _{comp} = 1.5V		250		uA/V
Maximum COMP Sourcing Current	I _{COMP_MAX_OUT}	V _{comp} = 1V		27		uA
Maximum COMP Sinking Current	I _{COMP_MAX_IN}	V _{comp} = 3V		27		uA
Top Switch Resistance	R _{DS(ON)T}			185		mΩ
Bottom Switch Resistance	R _{DS(ON)B}			100		mΩ
Top Switch Leakage Current	I _{LEAK_TOP}	V _{IN} =20V, V _{EN} =0V, V _{SW} =0V			0.5	uA
Bottom Switch Leakage Current	I _{LEAK_BOT}	V _{IN} =20V, V _{EN} =0V, V _{SW} =20V			0.5	uA
Top Switch Current Limit	I _{LIM_TOP}	Minimum Duty Cycle		4.4		A
Switch Frequency	F _{SW}			340		kHz
Minimum On Time	T _{ON_MIN}			120		ns
Minimum Off Time	T _{OFF_MIN}	V _{FB} =0V		120		ns
EN shut down threshold voltage	V _{EN_TH}	V _{EN} falling, FB=0V		1.2		V
EN shut down hysteresis	V _{EN_HYST}	V _{EN} rising, FB=0V		80		mV
Soft-Start Current	I _{SS}	SS=0V		9		μA
Thermal Shutdown	T _{TSD}			135		°C
Thermal shutdown hysteresis	T _{TSD_HYST}			15		°C

PIN DESCRIPTION

Pin No.	Name	Description
1	BST	Bootstrap pin for top switch. A 0.1μF or larger capacitor should be connected between this pin and the SW pin to supply current to the top switch and top switch driver.
2	VIN	Input voltage pin. VIN supplies power to the IC. Connect a 4.6V to 20V supply to VIN and bypass VIN to GND with a suitably large capacitor to eliminate noise on the input to the IC.
3	SW	SW is the switching node that supplies power to the output. Connect the output LC filter from SW to the output load.
4	PGND	Power ground pin.
5	FB	Output feedback pin. FB senses the output voltage and is regulated by the control loop to 0.923V. Connect a resistive divider at FB.
6	COMP	Compensation pin. COMP is used to compensate the regulation control loop. Connect a series RC network from COMP to GND to compensate the regulation control loop.
7	EN	Drive EN pin high to turn on the regulator and low to turn off the regulator.
8	SS	Soft-start pin. SS controls the rate at which the output voltage rises. Connect a capacitor at SS pin to ground to set the soft-start period.

BLOCK DIAGRAM

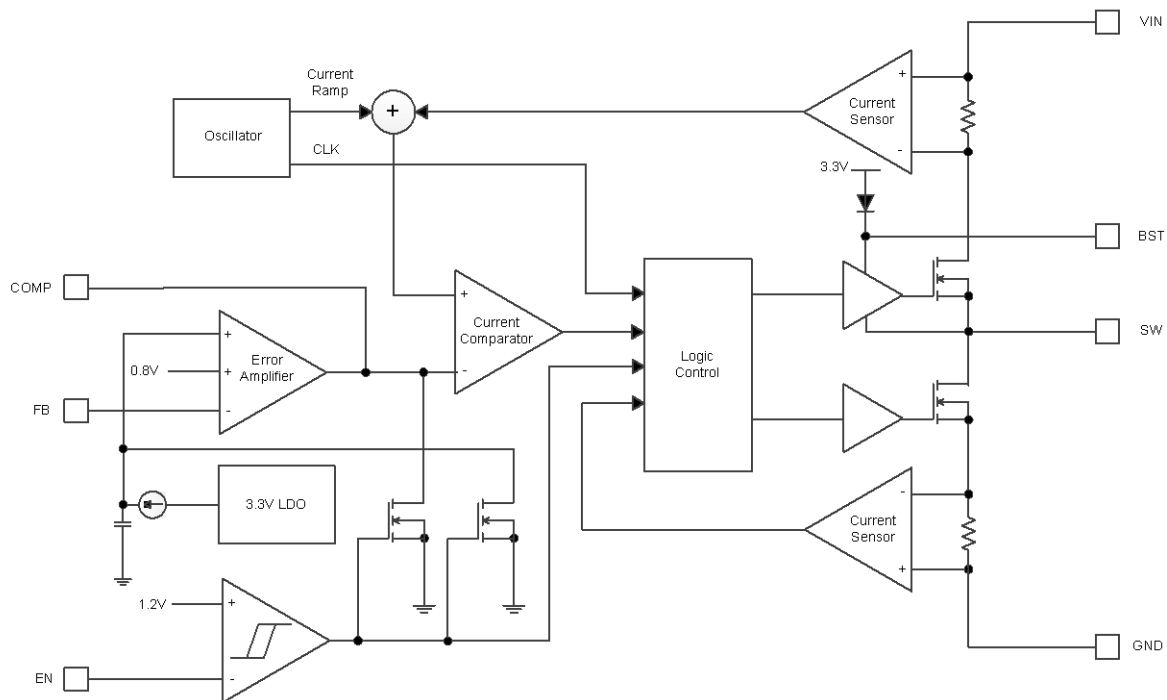

TYPICAL PERFORMANCE CHARACTERISTICS

Vin = 12V, Vo = 3.3V, L = 10 μ H, Cout = 47 μ F, TA = +25°C, unless otherwise noted

Steady State Test

VIN=12V, Vout=3.3V
Iout=3A, Iin=0.65A

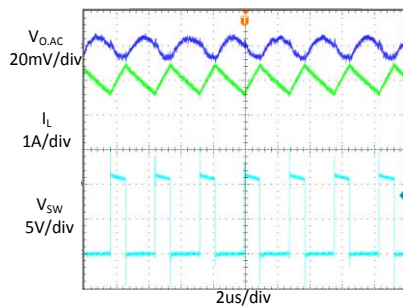

Startup through Enable

VIN=12V, Vout=3.3V
Iout=2.5A(Resistance load)

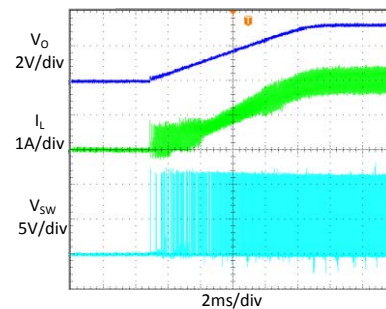

Shutdown through Enable

VIN=12V, Vout=3.3V
Iout=2.5A(Resistance load)

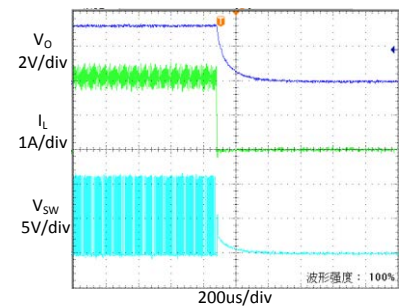

Heavy Load Operation

3A LOAD

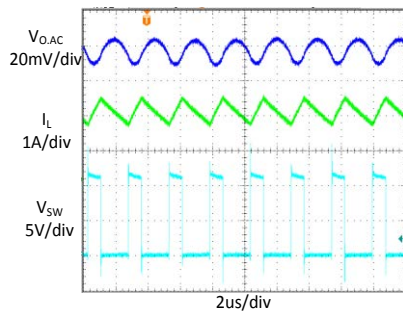

Medium Load Operation

1.5A LOAD

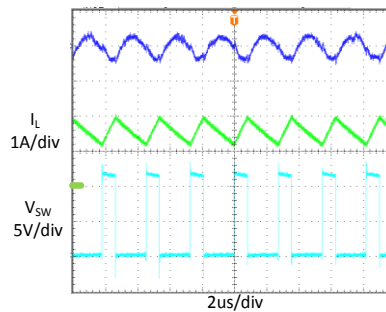

Light Load Operation

0.4A LOAD

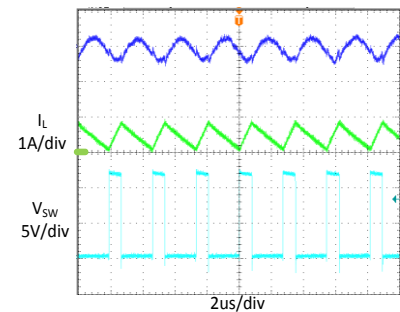

Short Circuit Protection

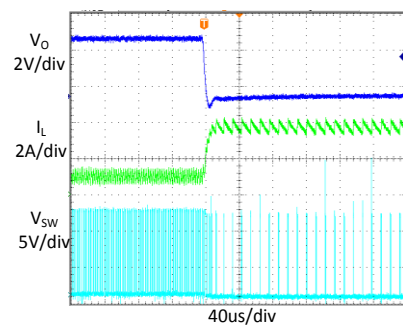

Short Circuit Recovery

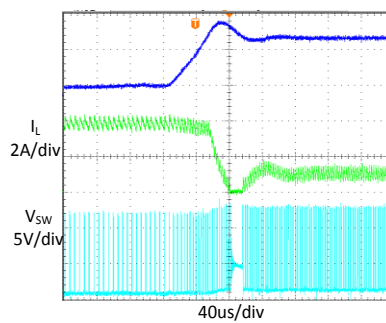

Load Transient

1.5A LOAD \rightarrow 3A LOAD \rightarrow 1.5A LOAD

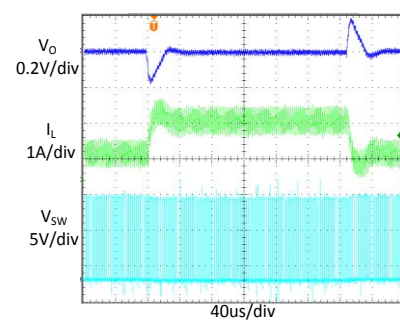

FUNCTIONAL DESCRIPTION

The MP1484 is a synchronous, current-mode, low step-down regulator. It regulates input voltages from 4.6V to 20V down to an output voltage as low as 0.923V, and is capable of supplying up to 3A of load current.

Current-Mode Control

The MP1484 utilizes current-mode control to regulate the output voltage. The output voltage is measured at the FB pin through a resistive voltage divider and the error is amplified by the internal transconductance error amplifier. COMP pin is output of the internal error amplifier and is compared to the switch current measured internally to control the output current limit.

PFM Mode

The MP1484 operates in PFM mode at light load. In PFM mode, switch frequency is continuously controlled in proportion to the load current, i.e. switch frequency is decreased when load current drops to boost power efficiency at light load by reducing switch-loss, while switch frequency is increased when load current rises, minimizing both load current and output voltage ripples.

Shut-Down Mode

The MP1484 operates in shut-down mode when voltage at EN pin is driven below 0.3V. In shut-down mode, the entire regulator is off and the supply current consumed by the MP1484 drops below 1uA.

Power Switch

N-Channel MOSFET switches are integrated on the MP1484 to down convert the input voltage to the regulated output voltage. Since the top MOSFET needs a gate voltage great than the input voltage, a boost capacitor connected between BST and SW pins is required to drive the gate of the top switch. The boost capacitor is charged by the internal 3.3V rail when SW is

Vin Under-Voltage Protection

A resistive divider can be connected between Vin and ground, with the central tap connected to EN, so that when Vin drops to the pre-set value, EN drops below 1.2V to trigger input under voltage lockout protection.

Output Current Run-Away Protection

At start-up, due to the high voltage at input and low voltage at output, current inertia of the output inductance can be easily built up, resulting in a large start-up output current. A valley current limit is designed in the MP1484 so that only when output current drops below the valley current limit can the bottom power switch be turned off. By such control mechanism, the output current at start-up is well controlled.

Output Short Protection

When output is shorted to ground, output current rapidly reaches its peak current limit and the top power switch is turned off. Right after the top power switch is turned off, the bottom power switch is turned on and stay on until the output current falls below the valley current limit. When output current is below the valley current limit, the top power switch will be turned on again and if the output short is still present, the top power switch is turned off when the peak current limit is reached and the bottom power switch is turned on. This cycle goes on until the output short is removed and the regulator comes into normal operation again.

Thermal Protection

When the temperature of the MP1484 rises above 135°C, it is forced into thermal shut-down. Only when core temperature drops below 120°C can the regulator becomes active again

APPLICATION REFERENCE

Reference 1:

V_{IN} : 4.6V ~ 20 V

V_{OUT} : 3.3V

I_{OUT} : 0~3A

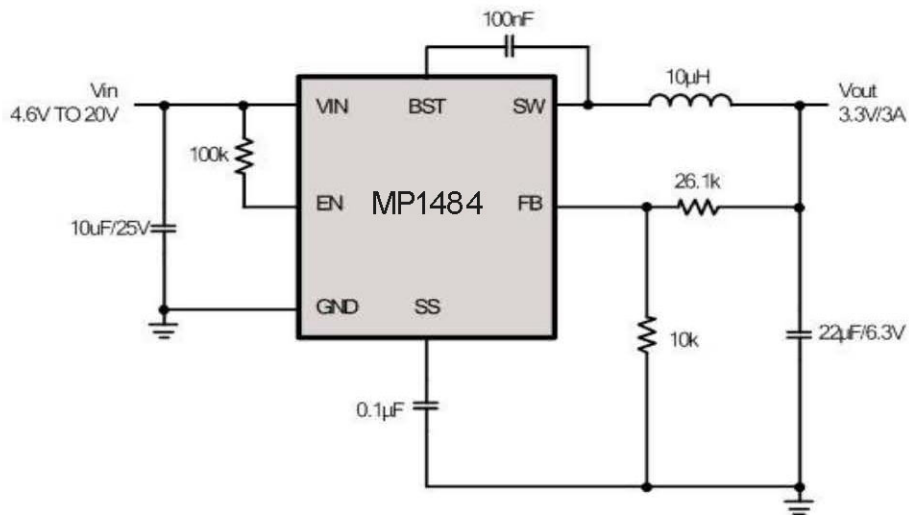

Reference 2:

V_{IN} : 4.6V ~ 20 V

V_{OUT} : 5V

I_{OUT} : 0~3A

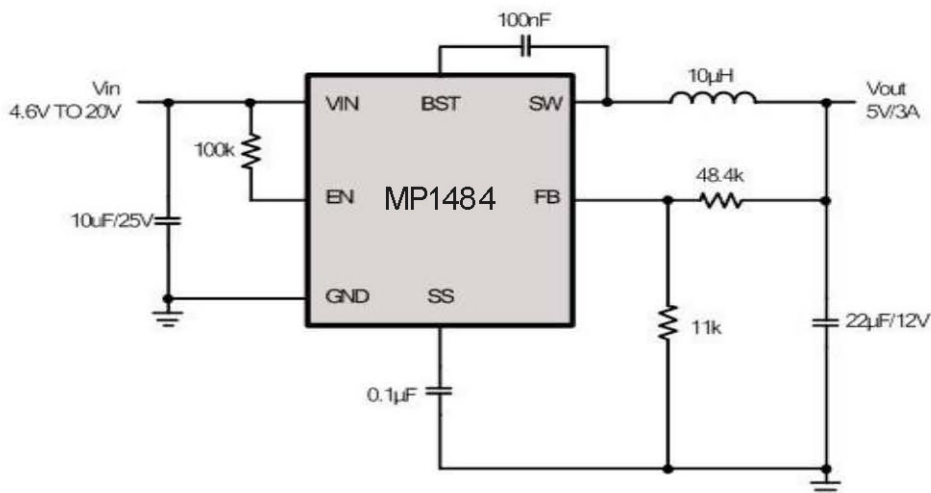

PACKAGE OUTLINE

