

## DESCRIPTION

The MP1655 is a fully integrated, high-frequency, synchronous, rectified, step-down, switch-mode converter with internal power MOSFETs. The MP1655 offers a very compact solution that achieves 5A of continuous output current with excellent load and line regulation over a wide input range. The MP1655 uses synchronous mode operation for higher efficiency over the output current load range.

Constant-on-time (COT) control operation provides very fast transient response, easy loop design, and very tight output regulation.

Full protection features include short-circuit protection (SCP), over-current protection (OCP), under-voltage protection (UVP), and thermal shutdown.

The MP1655 requires a minimal number of readily available, standard, external components and is available in a space-saving 6-pin QFN (2mmx2mm) package.

## FEATURES

- Wide 4.2V to 17V Operating Input Range
- 59mΩ/27mΩ Low  $R_{DS(ON)}$  Internal Power MOSFETs
- 210μA Low  $I_Q$  Current
- High-Efficiency Synchronous Mode Operation
- Power-Save Mode at Light Load
- Fast Load Transient Response
- 600kHz Switching Frequency
- Internal Soft Start (SS)
- Over-Current Protection (OCP) and Hiccup
- Thermal Shutdown
- Output Adjustable from 0.8V
- Available in a QFN-6 (2mmx2mm) Package

## APPLICATIONS

- Security Cameras
- Digital Set-Top Boxes
- Flat-Panel Television and Monitors
- General Purposes

All MPS parts are lead-free, halogen-free, and adhere to the RoHS directive. For MPS green status, please visit the MPS website under Quality Assurance. "MPS" and "The Future of Analog IC Technology" are registered trademarks of Monolithic Power Systems, Inc.

## TYPICAL APPLICATION

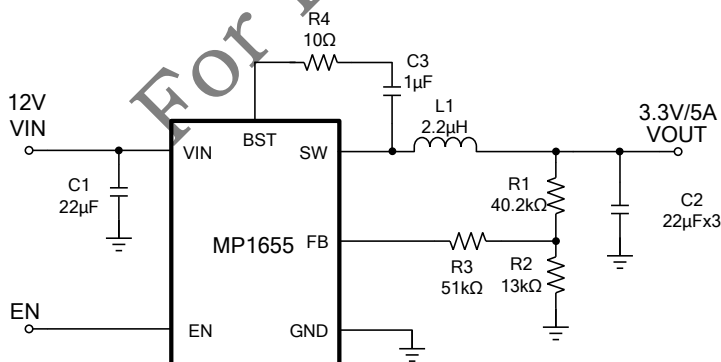

### Efficiency

$V_{OUT} = 3.3V$ ,  $L = 2.2\mu H$ ,  $DCR = 11.4m\Omega$

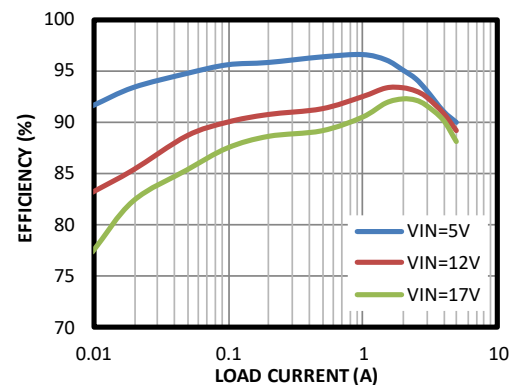

### ORDERING INFORMATION

Part Number*	Package	Top Marking
MP1655GG	QFN-6 (2mmx2mm)	See Below

\* For Tape & Reel, add suffix -Z (e.g. MP1655GG-Z)

### TOP MARKING

**FJY**

**LLL**

FJ: Product code of MP1655GG

Y: Year code

LLL: Lot number

### PACKAGE REFERENCE

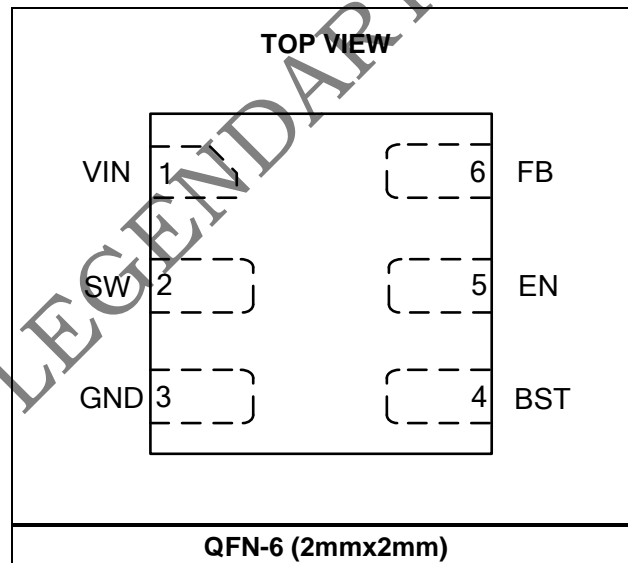

**ABSOLUTE MAXIMUM RATINGS (1)**

$V_{IN}$ .....	-0.3V to 18V
$V_{SW}$ .....	-0.3V (-0.6V for <1.5 $\mu$ s, -6.5V for <10ns) to 18V (19V for <10ns)
$V_{BST}$ .....	$V_{SW} + 5V$
$V_{EN}$ .....	-0.3V to 5V (2)
All other pins.....	-0.3V to 5V
Continuous power dissipation ( $T_A = +25^\circ C$ ) (3)(5)	2.8W
Junction temperature .....	150°C
Lead temperature .....	260°C
Storage temperature.....	-65°C to 150°C

**Recommended Operating Conditions (4)**

Supply voltage ( $V_{IN}$ ) .....	4.2V to 17V
Output voltage ( $V_{OUT}$ ).....	0.8V to $V_{IN} \times D_{MAX}$ or 10V max
Operating junction temp. ( $T_J$ ) ...	-40°C to +125°C

**Thermal Resistance**

	$\theta_{JA}$	$\theta_{JC}$
QFN-6 (2mmx2mm)		
EV1655-G-00A (5) .....	44.....	15 ... °C/W
JESD51-7 (6) .....	80.....	16 ... °C/W

**NOTES:**

- 1) Exceeding these ratings may damage the device.
- 2) For details on EN's ABS max rating, refer to the EN Control section on page 13.
- 3) The maximum allowable power dissipation is a function of the maximum junction temperature  $T_J$  (MAX), the junction-to-ambient thermal resistance  $\theta_{JA}$ , and the ambient temperature  $T_A$ . The maximum allowable continuous power dissipation at any ambient temperature is calculated by  $P_D$  (MAX) =  $(T_J$  (MAX)- $T_A$ )/ $\theta_{JA}$ . Exceeding the maximum allowable power dissipation produces an excessive die temperature, causing the regulator to go into thermal shutdown. Internal thermal shutdown circuitry protects the device from permanent damage.
- 4) The device is not guaranteed to function outside of its operating conditions.
- 5) Measured on EV1655-G-00A, 4-layer PCB
- 6) Measured on JESD51-7, 4-layer PCB.

FOR LEGENDARY USE ONLY

## ELECTRICAL CHARACTERISTICS

$V_{IN} = 12V$ ,  $T_J = -40^{\circ}C$  to  $+125^{\circ}C$  <sup>(7)</sup>, typical value is tested at  $T_J = +25^{\circ}C$ , unless otherwise noted.

Parameter	Symbol	Condition	Min	Typ	Max	Units
Supply current (shutdown)	$I_{IN}$	$V_{EN} = 0V$			10	$\mu A$
Supply current (quiescent)	$I_Q$	$V_{EN} = 2V$ , $V_{FB} = 0.85V$	170	210	250	$\mu A$
HS switch on resistance	$HS_{RDS(ON)}$	$V_{BST-SW} = 3.3V$		59		$m\Omega$
LS switch on resistance	$LS_{RDS(ON)}$			27		$m\Omega$
Switch leakage	$SW_{LKG}$	$V_{EN} = 0V$ , $V_{SW} = 12V$			10	$\mu A$
Valley current limit	$I_{LIMIT}$	$V_{OUT} = 0V$		6.5		A
ZCD	$I_{ZCD}$	$V_{OUT} = 3.3V$ , $L_o = 2.2\mu H$ , $I_{OUT} = 0A$	-250	20	250	mA
Oscillator frequency	$f_{SW}$	$V_{FB} = 0.75V$		600		kHz
Minimum on time <sup>(8)</sup>	$T_{ON\_MIN}$			45		ns
Minimum off time <sup>(8)</sup>	$T_{OFF\_MIN}$			180		ns
Feedback voltage	$V_{REF}$	$T_J = +25^{\circ}C$	793	805	817	mV
Feedback current	$I_{FB}$			10	100	nA
FB UV threshold (H to L)	$V_{UV\_th}$	Hiccup entry		75%		Vref
Hiccup duty cycle <sup>(8)</sup>	$D_{Hiccup}$			25		%
EN rising threshold	$V_{EN\_RISING}$		1.14	1.2	1.26	V
EN hysteresis	$V_{EN\_HYS}$			100		mV
EN input current	$I_{EN}$	$V_{EN} = 2V$		2		$\mu A$
$V_{IN}$ under-voltage lockout threshold rising	$INUV_{Vth}$		3.7	4	4.18	V
$V_{IN}$ under-voltage lockout threshold hysteresis	$INUV_{HYS}$			330		mV
Soft-start period	$T_{SS}$		1.6	2.5	3	ms
Thermal shutdown <sup>(8)</sup>	$T_{SD}$			150		$^{\circ}C$
Thermal hysteresis <sup>(8)</sup>	$T_{SDHYS}$			20		$^{\circ}C$

### NOTES:

- 7) Guaranteed by over-temperature correlation, not tested in production.  
 8) Guaranteed by design and engineering sample characterization.

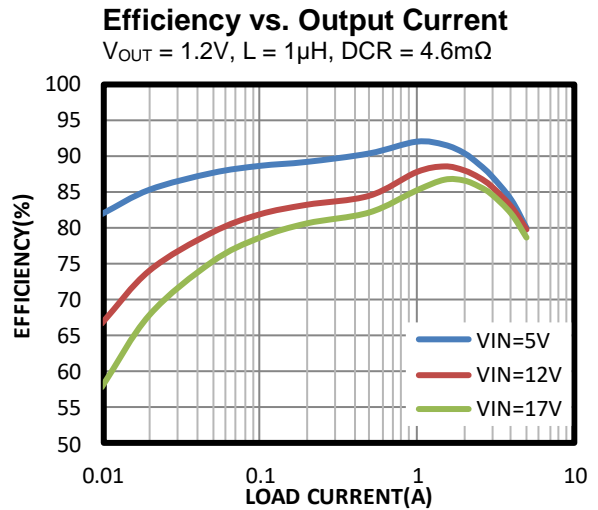
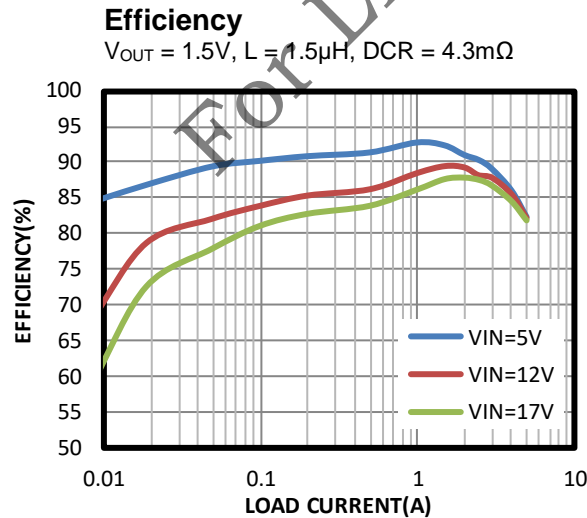
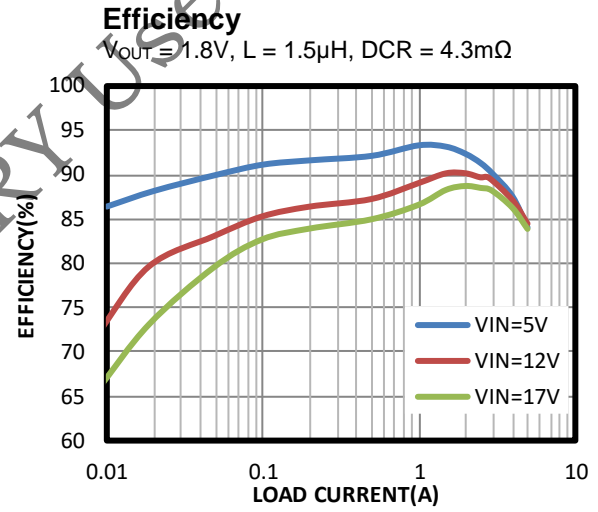
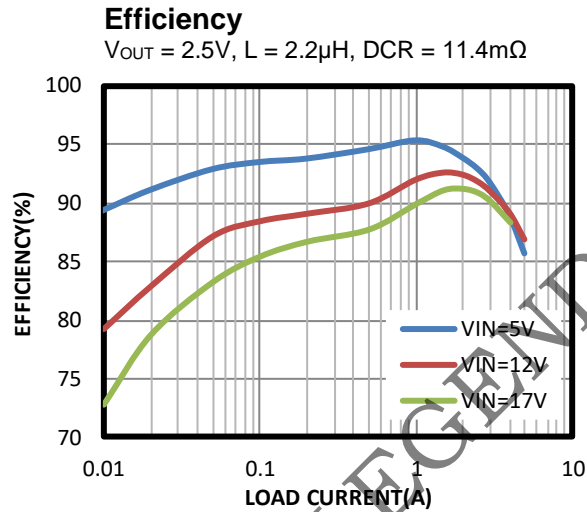
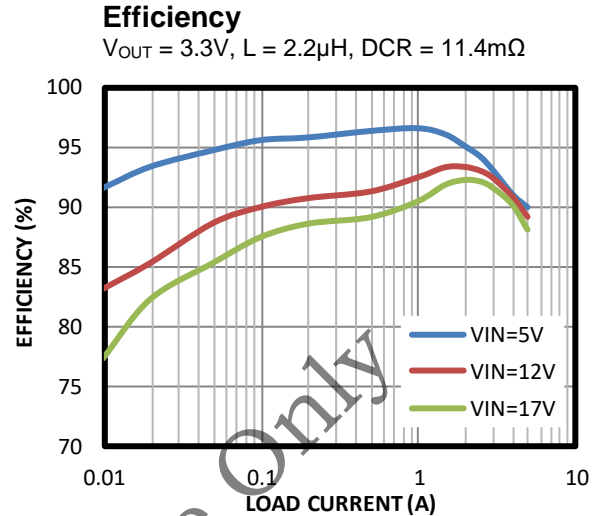
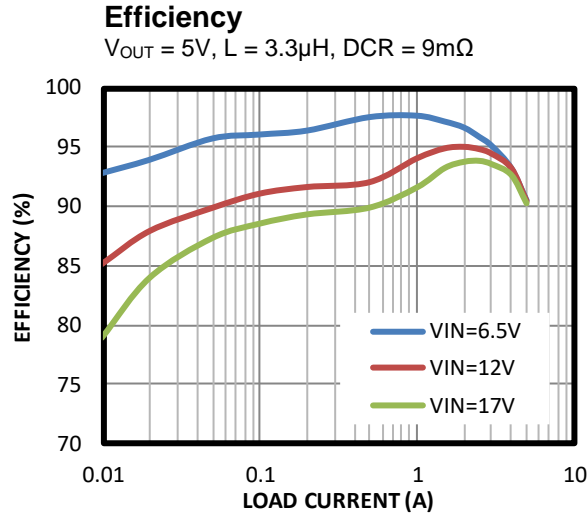
**TYPICAL PERFORMANCE CHARACTERISTICS**
 $V_{IN} = 12V$ ,  $V_{OUT} = 3.3V$ ,  $L = 2.2\mu H$ ,  $T_A = +25^\circ C$ , unless otherwise noted.

**TYPICAL PERFORMANCE CHARACTERISTICS (continued)**
 $V_{IN} = 12V, V_{OUT} = 3.3V, L = 2.2\mu H, T_A = +25^{\circ}C$ , unless otherwise noted.

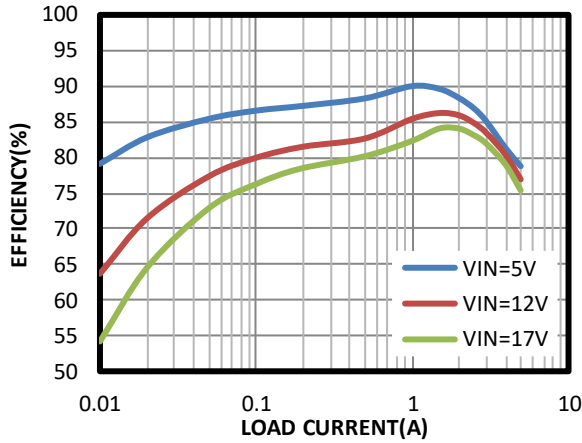
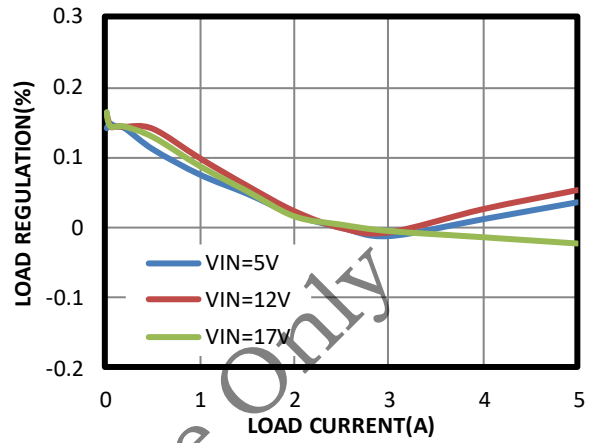
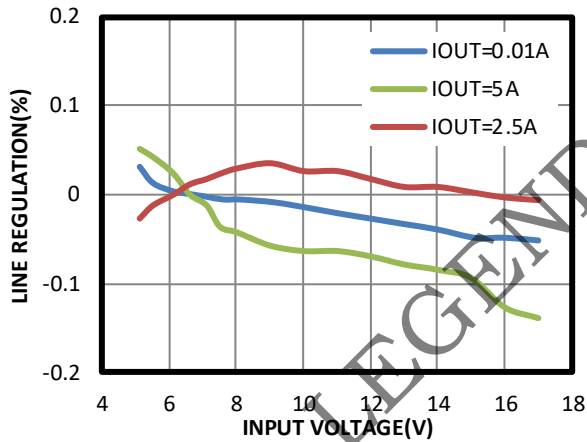
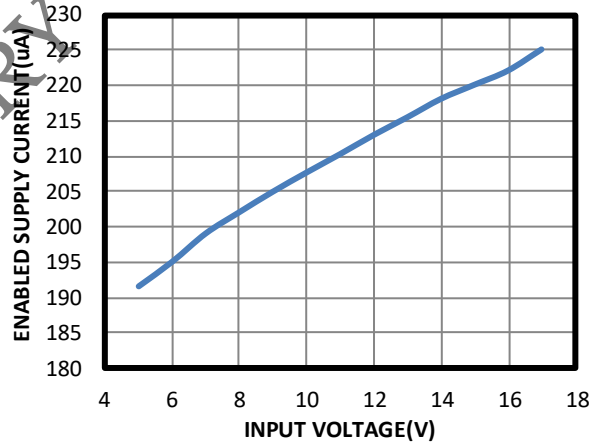
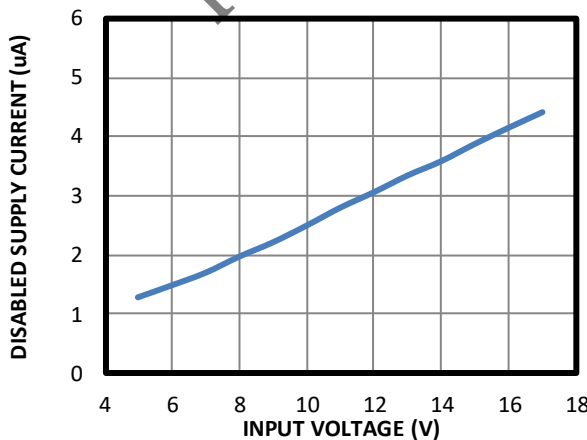
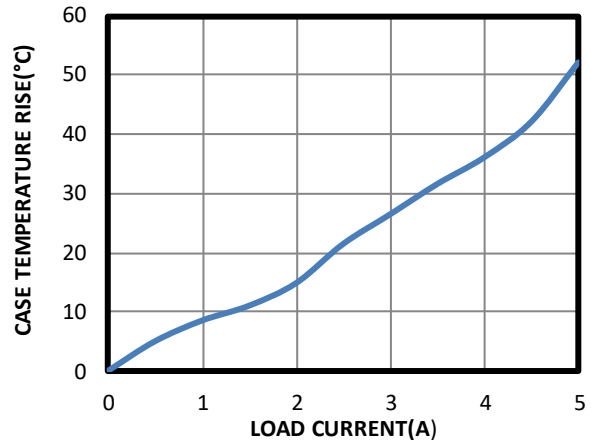
**Efficiency vs. Output Current**
 $V_{OUT} = 1V, L = 1\mu H, DCR = 4.6m\Omega$ 

**Load Regulation**

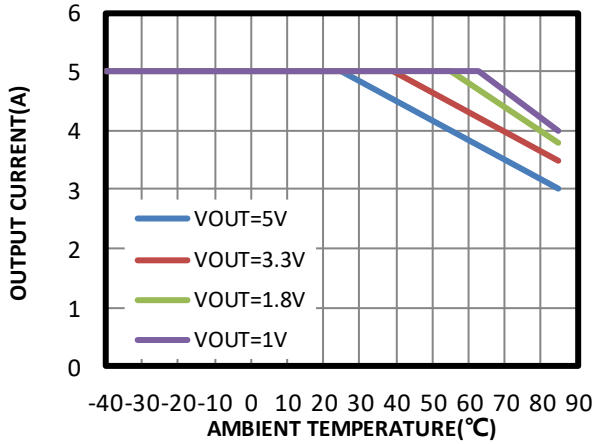
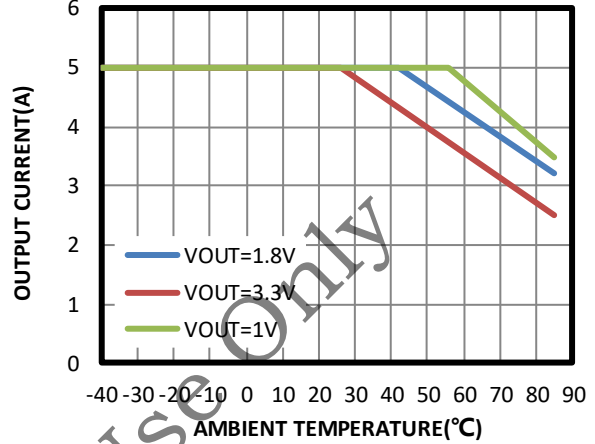
**Line Regulation**

**Enabled Supply Current vs. Input Voltage**
 $V_{EN} = 2V, V_{FB} = 0.85V$ 

**Disabled Supply Current vs. Input Voltage**
 $V_{EN} = 0V$ 

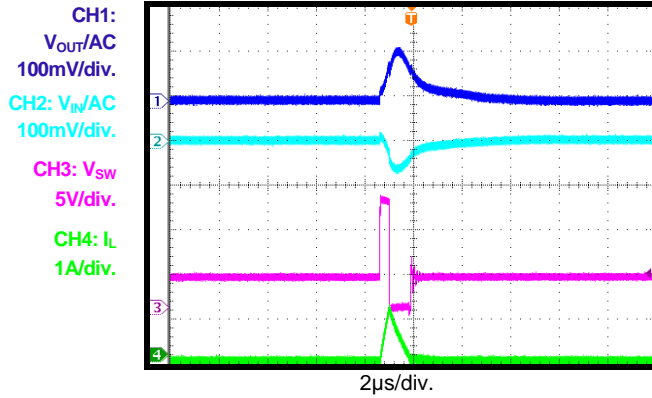
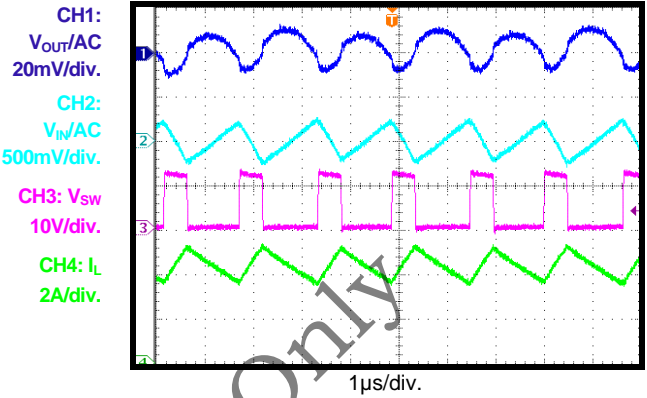
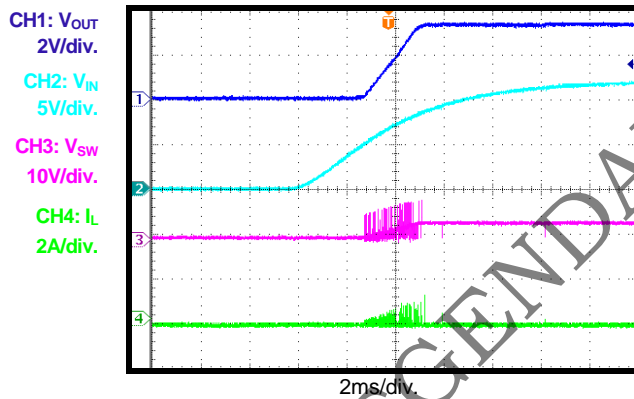
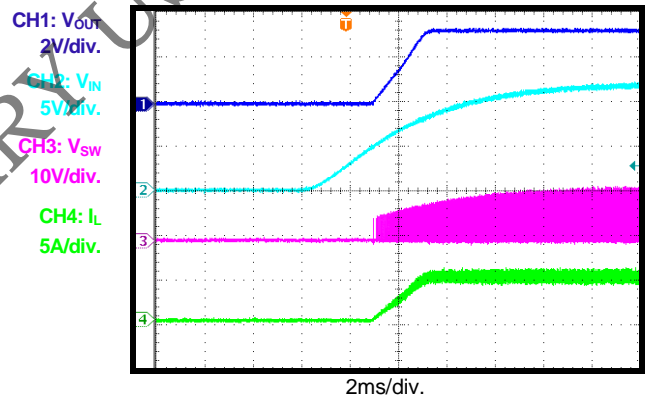
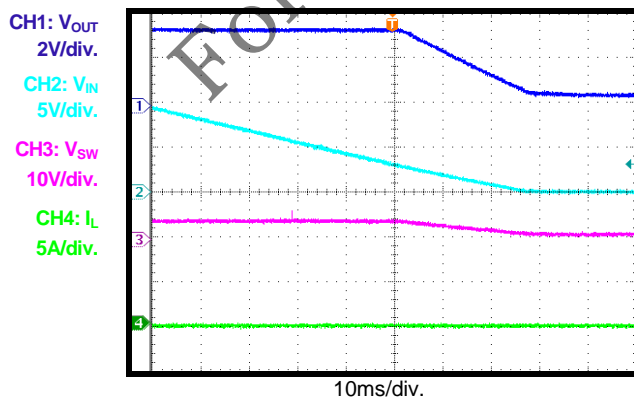
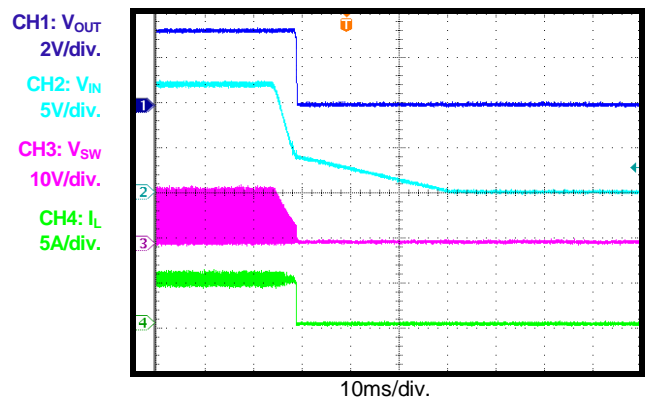
**Case Temperature Rise vs. Load Current**

**TYPICAL PERFORMANCE CHARACTERISTICS (continued)**
 $V_{IN} = 12V$ ,  $V_{OUT} = 3.3V$ ,  $L = 2.2\mu H$ ,  $T_A = +25^\circ C$ , unless otherwise noted.

**Output Current Derating vs. Ambient Temperature**
 $V_{IN} = 12V$ ,  $T_J < 125^\circ C$ ,  
 four-layer PCB, size: 6.4cm x 6.4cm.

**Output Current Derating vs. Ambient Temperature**
 $V_{IN} = 5V$ ,  $T_J < 125^\circ C$ ,  
 four-layer PCB, size: 6.4cm x 6.4cm.

For LEGENDARY Use Only

**TYPICAL PERFORMANCE CHARACTERISTICS (continued)**
 $V_{IN} = 12V$ ,  $V_{OUT} = 3.3V$ ,  $L = 2.2\mu H$ ,  $T_A = +25^\circ C$ , unless otherwise noted.

**Input/Output Ripple**
 $I_{OUT} = 0A$ 

**Input/Output Ripple**
 $I_{OUT} = 5A$ 

**Start-Up through Input Voltage**
 $I_{OUT} = 0A$ 

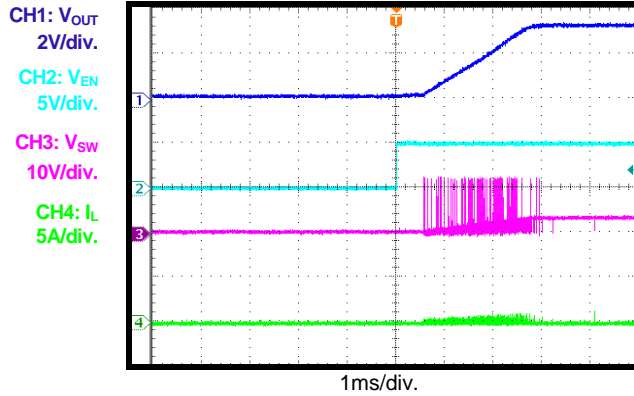
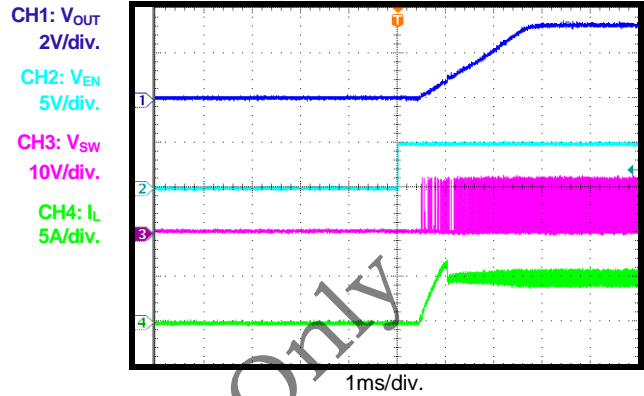
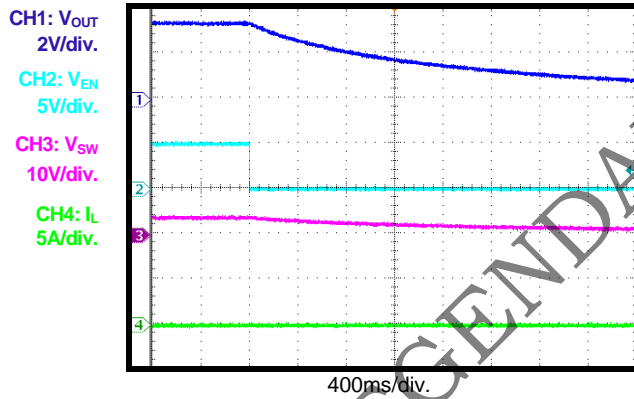
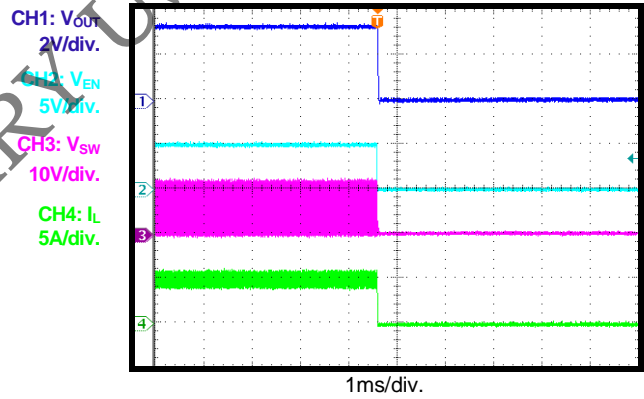
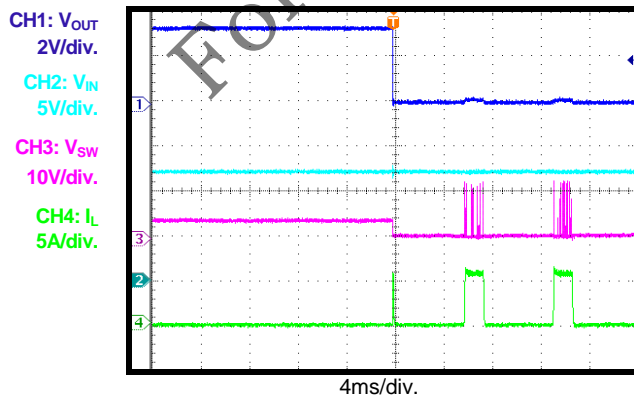
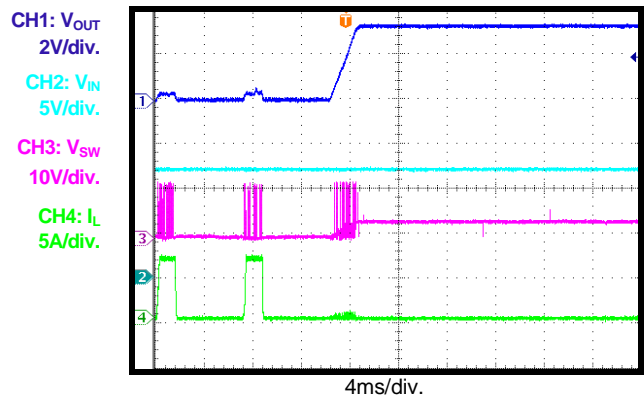
**Start-Up through Input Voltage**
 $I_{OUT} = 5A$ 

**Shutdown through Input Voltage**
 $I_{OUT} = 0A$ 

**Shutdown through Input Voltage**
 $I_{OUT} = 5A$ 



**TYPICAL PERFORMANCE CHARACTERISTICS (continued)**
 $V_{IN} = 12V$ ,  $V_{OUT} = 3.3V$ ,  $L = 2.2\mu H$ ,  $T_A = +25^\circ C$ , unless otherwise noted.

**Start-Up through Enable**
 $I_{OUT} = 0A$ 

**Start-Up through Enable**
 $I_{OUT} = 5A$ 

**Shutdown through Enable**
 $I_{OUT} = 0A$ 

**Shutdown through Enable**
 $I_{OUT} = 5A$ 

**Short-Circuit Entry**
 $I_{OUT} = 0A$ 

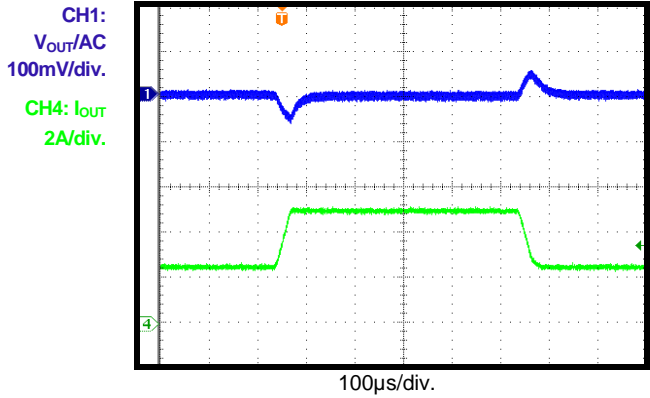
**Short-Circuit Recovery**
 $I_{OUT} = 0A$ 

### TYPICAL PERFORMANCE CHARACTERISTICS *(continued)*

$V_{IN} = 12V$ ,  $V_{OUT} = 3.3V$ ,  $L = 2.2\mu H$ ,  $T_A = +25^\circ C$ , unless otherwise noted.

#### Load Transient Response

$I_{OUT} = 2.5 - 5A$



FOR LEGENDARY Use Only

**PIN FUNCTIONS**

Package Pin #	Name	Description
1	VIN	<b>Supply voltage.</b> The MP1655 operates from a 4.2V to 17V input rail. A capacitor (C1) is required to decouple the input rail. Connect VIN using a wide PCB trace.
2	SW	<b>Switch output.</b> Connect SW using a wide PCB trace.
3	GND	<b>System ground.</b> GND is the reference ground of the regulated output voltage. GND requires extra care during the PCB layout. Connect GND with copper traces and vias.
4	BST	<b>Bootstrap.</b> Connect a capacitor and a resistor between SW and BST to form a floating supply across the high-side switch driver. Use a 1 $\mu$ F BST capacitor.
5	EN	<b>Enable.</b> Drive EN high to enable the MP1655. For automatic start-up, connect EN to VIN with a 100k $\Omega$ pull-up resistor.
6	FB	<b>Feedback.</b> Connect FB to the tap of an external resistor divider from the output to GND to set the output voltage. The frequency foldback comparator lowers the oscillator frequency when the FB voltage drops below 600mV to prevent current-limit runaway during a short-circuit fault.

For LEGENDARY Use Only

### BLOCK DIAGRAM

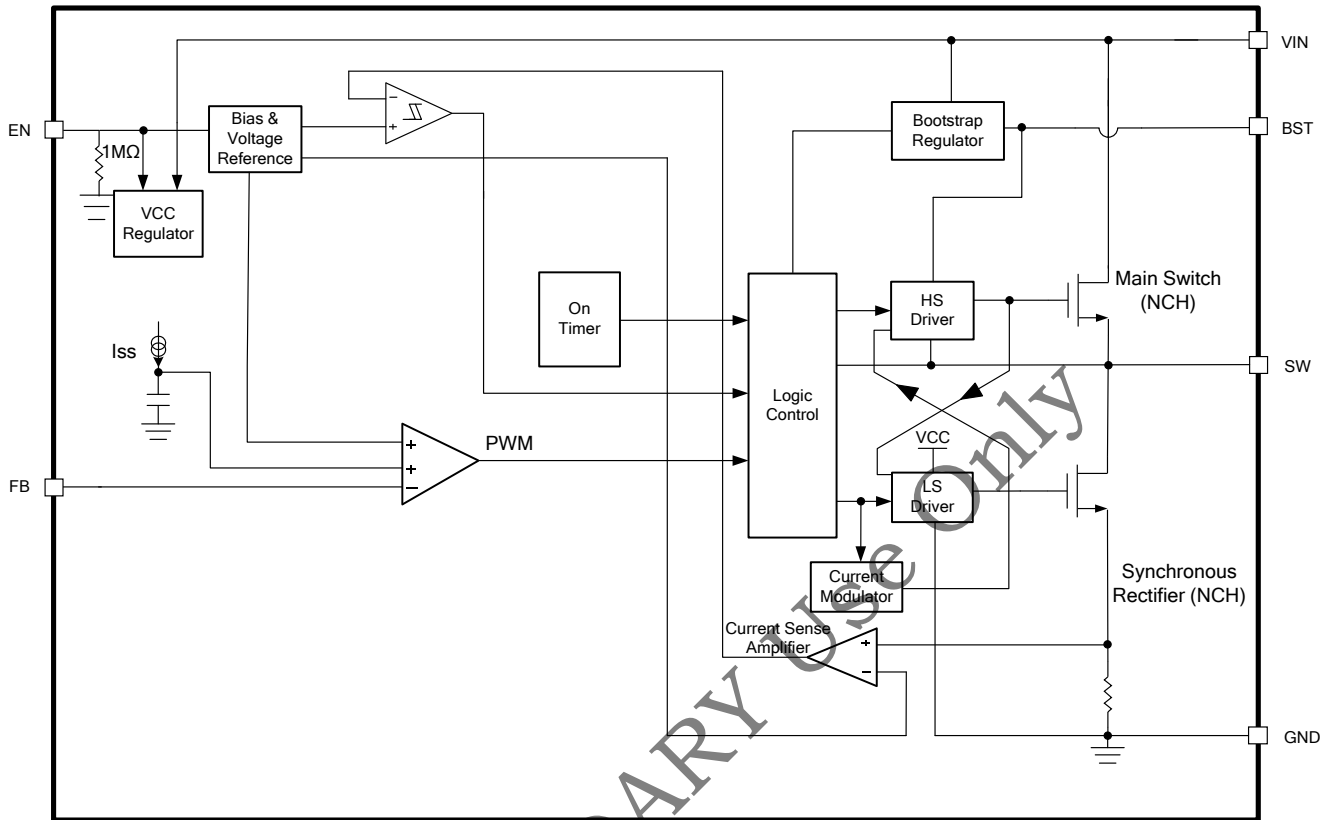

Figure 1: Functional Block Diagram

FOR LEGENDARY USE ONLY

## OPERATION

The MP1655 is fully integrated, synchronous, rectified, step-down, switch mode converter. Constant-on-time (COT) control is employed to provide fast transient response and easy loop stabilization. At the beginning of each cycle, the high-side MOSFET (HS-FET) is turned on when the FB voltage ( $V_{FB}$ ) drops below the reference voltage ( $V_{REF}$ ). The HS-FET is turned on for a fixed interval determined by the one-shot on-timer. The on-timer is determined by both the output voltage and input voltage to make the switching frequency fairly constant over the input voltage range.

After the on period elapses, the HS-FET is turned off until the next period begins. By repeating operation this way, the converter regulates the output voltage.

Continuous conduction mode (CCM) is when the output current is high and the inductor current is always above zero amps. The low-side MOSFET (LS-FET) is turned on when the HS-FET is in its off state to minimize conduction loss. There is a dead short between the input and GND if both the HS-FET and LS-FET are turned on at the same time. This is called shoot-through. To avoid shoot-through, a dead time is generated internally between the HS-FET off and LS-FET on period or the LS-FET off and HS-FET on period.

When the MP1655 works in pulse-frequency modulation (PFM) mode during light-load operation, the MP1655 reduces the switching frequency automatically to maintain high efficiency, and the inductor current drops almost to zero. When the inductor current reaches zero, the low-side driver goes into tri-state (Hi-Z). Therefore, the output capacitors discharge slowly to GND through the resistors R1 and R2. When  $V_{FB}$  drops below  $V_{REF}$ , the HS-FET is turned on. This operation improves device efficiency greatly when the output current is low.

Light-load operation is also called skip mode because the HS-FET does not turn on as frequently as it does during heavy-load conditions. The HS-FET turn-on frequency is a function of the output current. As the output current increases, the current modulator regulation time period becomes shorter, and the

HS-FET turns on more frequently. The switching frequency increases in turn. The output current reaches the critical level when the current modulator time is zero and can be determined with Equation (1):

$$I_{OUT} = \frac{(V_{IN} - V_{OUT}) \times V_{OUT}}{2 \times L \times F_{SW} \times V_{IN}} \quad (1)$$

The device reverts to pulse-width modulation (PWM) mode once the output current exceeds the critical level. Afterward, the switching frequency remains fairly constant over the output current range.

### Enable (EN) Control

EN is a digital control pin that turns the regulator on and off. Drive EN high to turn on the regulator. Drive EN low to turn off the regulator. An internal  $1M\Omega$  resistor from EN to GND allows EN to be floated to shut down the chip.

EN is clamped internally using a 2.8V series Zener diode (see Figure 2). Connecting the EN input through a pull-up resistor to  $V_{IN}$  limits the EN input current to less than  $100\mu A$ , preventing damage to the Zener diode.

For example, if connecting 12V to  $V_{IN}$ , then  $R_{PULLUP} \geq (12V - 2.8V) / (100k\Omega + 35k\Omega) = 68\mu A$ .

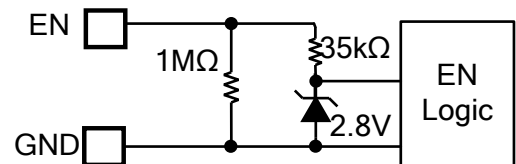

**Figure 2: Zener Diode between EN and GND**

### Under-Voltage Lockout (UVLO)

Under-voltage lockout (UVLO) protects the chip from operating at an insufficient supply voltage. The MP1655 UVLO comparator monitors the output voltage of the internal regulator ( $V_{CC}$ ). The UVLO rising threshold is about 4V, while its falling threshold is 3.67V.

### Internal Soft Start (SS)

Soft start prevents the converter output voltage from overshooting during start-up. When the chip starts up, the internal circuitry generates a soft-start voltage (SS) that ramps up from 0V to 1.2V. When SS is lower than REF, SS overrides REF, so the error amplifier uses SS as the reference. When SS exceeds REF, the

error amplifier uses REF as the reference. The SS time is set to 2.5ms internally.

### Over-Current Protection (OCP) and Short-Circuit Protection (SCP)

The MP1655 has a valley current-limit control. The inductor current is monitored during the LS-FET on state. When the sensed inductor current reaches the valley current limit, the low-side limit comparator turns over, the device enters over-current protection (OCP) mode, and the HS-FET waits until the valley current limit is removed before turning on again. Meanwhile, the output voltage drops until  $V_{FB}$  is below the under-voltage (UV) threshold (typically 75% below the reference). Once UV is triggered, the MP1655 enters hiccup mode to restart the part periodically.

During OCP, the device attempts to recover from the over-current fault with hiccup mode. This means that the chip disables the output power stage, discharges the soft start, and then attempts to soft start again automatically. If the over-current condition still remains after the soft start ends, the device repeats this operation cycle until the over-current condition is removed, and then the output rises back to the regulation level. OCP is a non-latch protection.

### Pre-Bias Start-Up

The MP1655 is designed for monotonic start-up into pre-biased loads. If the output is pre-biased to a certain voltage during start-up, the BST voltage is refreshed and charged, and the voltage on the soft-start is charged as well. If the BST voltage exceeds its rising threshold voltage, and the soft start voltage exceeds the sensed output voltage at FB, the part begins working normally.

### Thermal Shutdown

Thermal shutdown prevents the chip from operating at exceedingly high temperatures. When the silicon die temperature exceeds 150°C, the entire chip shuts down. When the temperature falls below its lower threshold (typically 130°C), the chip is enabled again.

### Floating Driver and Bootstrap Charging

An external bootstrap capacitor powers the floating power MOSFET driver. This floating driver has its own UVLO protection with a rising threshold of 2.2V and a hysteresis of 150mV.  $V_{IN}$  regulates the bootstrap capacitor voltage internally through D1, M1, C3, L1, and C2 (see Figure 3). If  $V_{IN} - V_{SW}$  exceeds 3.3V, U2 regulates M1 to maintain a 3.3V BST voltage across C3.

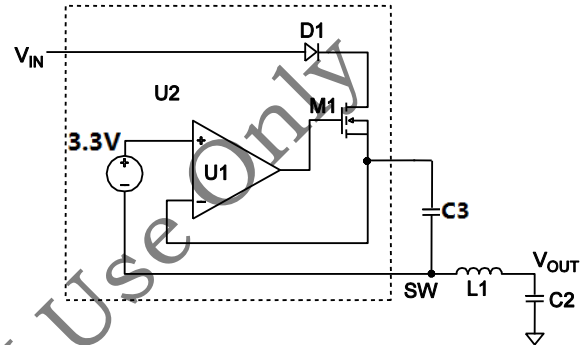

**Figure 3: Internal Bootstrap Charger**

### Start-Up and Shutdown

If both  $V_{IN}$  and EN exceed their respective thresholds, the chip starts up. The reference block starts first, generating a stable reference voltage and current, and then the internal regulator is enabled. The regulator provides a stable supply for the remaining circuits.

Three events can shut down the chip: EN low,  $V_{IN}$  low, and thermal shutdown. The shutdown procedure starts by blocking the signaling path initially to avoid any fault triggering. The internal supply rail is then pulled down.

## APPLICATION INFORMATION

### Setting the Output Voltage

The external resistor divider is used to set the output voltage. First, choose a value for R2. R2 should be chosen reasonably, since a small R2 leads to considerable quiescent current loss, while a large R2 makes FB noise sensitive. R1 can be determined with Equation (2)

$$R1 = \frac{V_{OUT} - V_{REF}}{V_{REF}} \times R2 \quad (2)$$

The feedback circuit is shown in Figure 4.

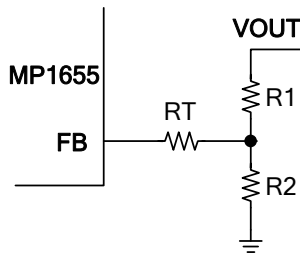

**Figure 4: Feedback Network**

Table 1 lists the recommended parameters for common output voltages.

**Table 1: Parameters Selection for Common Output Voltages<sup>(9)</sup>**

V <sub>OUT</sub> (V)	R1 (kΩ)	R2 (kΩ)	RT (kΩ)	L (μH)
5	40.2	7.68	51	3.3
3.3	40.2	13	51	2.2
2.5	40.2	19.1	76.8	2.2
1.8	40.2	32.4	100	1.5
1.5	40.2	45.3	147	1.5
1.2	40.2	82	147	1
1	20.5	84.5	249	1

**NOTE:**

9) For a detailed design circuit, refer to the Typical Application Circuits on page 18 to 20.

### Selecting the Inductor

An inductor is necessary for supplying constant current to the output load while being driven by the switched input voltage. A larger-value inductor results in less ripple current and lower output ripple voltage but also has a larger physical footprint, higher series resistance, and lower saturation current. A good rule for determining the inductance value is to design the peak-to-peak ripple current in the inductor to be between 30 - 60% of the maximum output current and to keep the peak inductor current below the maximum switch current limit. The

inductance value can be calculated with Equation (3):

$$L = \frac{V_{OUT}}{F_{SW} \times \Delta I_L} \times \left(1 - \frac{V_{OUT}}{V_{IN}}\right) \quad (3)$$

Where  $\Delta I_L$  is the peak-to-peak inductor ripple current.

The inductor should not saturate under the maximum inductor peak current. The peak inductor current can be calculated with Equation (4):

$$I_{LP} = I_{OUT} + \frac{V_{OUT}}{2F_{SW} \times L} \times \left(1 - \frac{V_{OUT}}{V_{IN}}\right) \quad (4)$$

### Selecting the Input Capacitor

The input current to the step-down converter is discontinuous and therefore requires a capacitor to supply AC current to the step-down converter while maintaining the DC input voltage. For the best performance, use ceramic capacitors placed as close to V<sub>IN</sub> as possible. Capacitors with X5R and X7R ceramic dielectrics are recommended because they are fairly stable with temperature fluctuations.

The capacitors must also have a ripple current rating greater than the maximum input ripple current of the converter. The input ripple current can be estimated with Equation (5):

$$I_{CIN} = I_{OUT} \times \sqrt{\frac{V_{OUT}}{V_{IN}} \times \left(1 - \frac{V_{OUT}}{V_{IN}}\right)} \quad (5)$$

The worst-case condition occurs at V<sub>IN</sub> = 2V<sub>OUT</sub>, shown in Equation (6):

$$I_{CIN} = \frac{I_{OUT}}{2} \quad (6)$$

For simplification, choose an input capacitor with an RMS current rating greater than half of the maximum load current.

The input capacitance value determines the input voltage ripple of the converter. If there is an input voltage ripple requirement in the system, choose the input capacitor that meets the specification.

The input voltage ripple can be estimated with Equation (7):

$$\Delta V_{IN} = \frac{I_{OUT}}{F_{SW} \times C_{IN}} \times \frac{V_{OUT}}{V_{IN}} \times \left(1 - \frac{V_{OUT}}{V_{IN}}\right) \quad (7)$$

The worst-case condition occurs at  $V_{IN} = 2V_{OUT}$ , shown in Equation (8):

$$\Delta V_{IN} = \frac{1}{4} \times \frac{I_{OUT}}{F_{SW} \times C_{IN}} \quad (8)$$

### Selecting the Output Capacitor

An output capacitor is required to maintain the DC output voltage. Ceramic or POSCAP capacitors are recommended. The output voltage ripple can be estimated with Equation (9):

$$\Delta V_{OUT} = \frac{V_{OUT}}{F_{SW} \times L} \times \left(1 - \frac{V_{OUT}}{V_{IN}}\right) \times \left(R_{ESR} + \frac{1}{8 \times F_{SW} \times C_{OUT}}\right) \quad (9)$$

In the case of ceramic capacitors, the impedance at the switching frequency is dominated by the capacitance. The output voltage ripple is caused mainly by the capacitance. For simplification, the output voltage ripple can be estimated with Equation (10):

$$\Delta V_{OUT} = \frac{V_{OUT}}{8 \times F_{SW}^2 \times L \times C_{OUT}} \times \left(1 - \frac{V_{OUT}}{V_{IN}}\right) \quad (10)$$

The output voltage ripple caused by the ESR is very small.

In the case of POSCAP capacitors, the ESR dominates the impedance at the switching frequency. For simplification, the output ripple can be approximated with Equation (11):

$$\Delta V_{OUT} = \frac{V_{OUT}}{F_{SW} \times L} \times \left(1 - \frac{V_{OUT}}{V_{IN}}\right) \times R_{ESR} \quad (11)$$

Choosing a larger output capacitor can achieve a better load transient response, but the maximum output capacitor limitation should also be considered in the design application. If the output capacitor value is too high, the output voltage cannot reach the design value during the soft-start time and fails to regulate.

The maximum output capacitor value ( $C_{o\_max}$ ) can be limited approximately with Equation (12):

$$C_{O\_MAX} = (I_{LIM\_AVG} - I_{OUT}) \times T_{SS} / V_{OUT} \quad (12)$$

Where  $I_{LIM\_AVG}$  is the average start-up current during the soft-start period, and  $T_{SS}$  is the soft-start time.

### PCB Layout Guidelines

Efficient layout of the switching power supplies is critical for stable operation. A poor layout design can result in poor line or load regulation and stability issues. For best results, refer to Figure 5 and follow the guidelines below.

1. Place the high current paths (GND, VIN, and SW) very close to the device with short, direct, and wide traces.
2. Place the input capacitor as close to VIN and GND as possible (within 1mm).
3. Place the external feedback resistors next to FB.
4. Keep the switching node SW short and away from the feedback network.

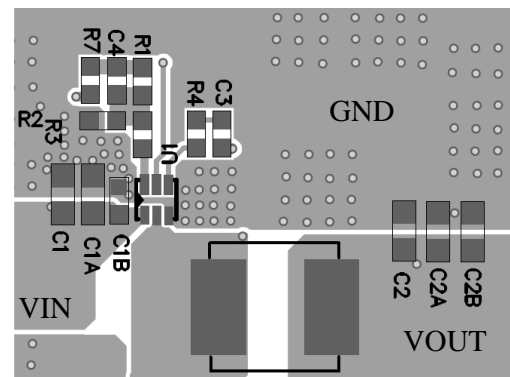

**Top Layer**

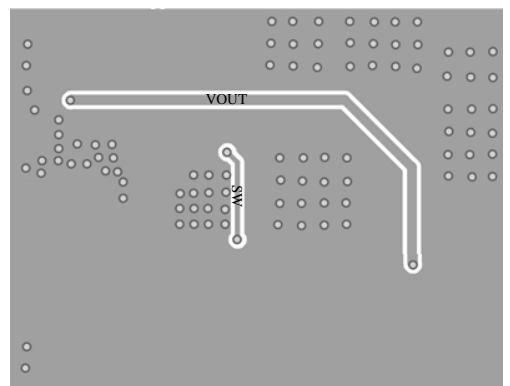

**Bottom Layer**

**Figure 5: Recommended Layout**



**Design Example**

Table 2 shows a design example when ceramic capacitors are applied.

$V_{IN}$	12V
$V_{OUT}$	3.3V
$I_{OUT}$	5A

The detailed application schematics are shown in Figure 6 through Figure 12. The typical performance and waveforms are shown in the Typical Performance Characteristics section. For more devices applications, please refer to the related evaluation board datasheet.

FOR LEGENDARY Use Only

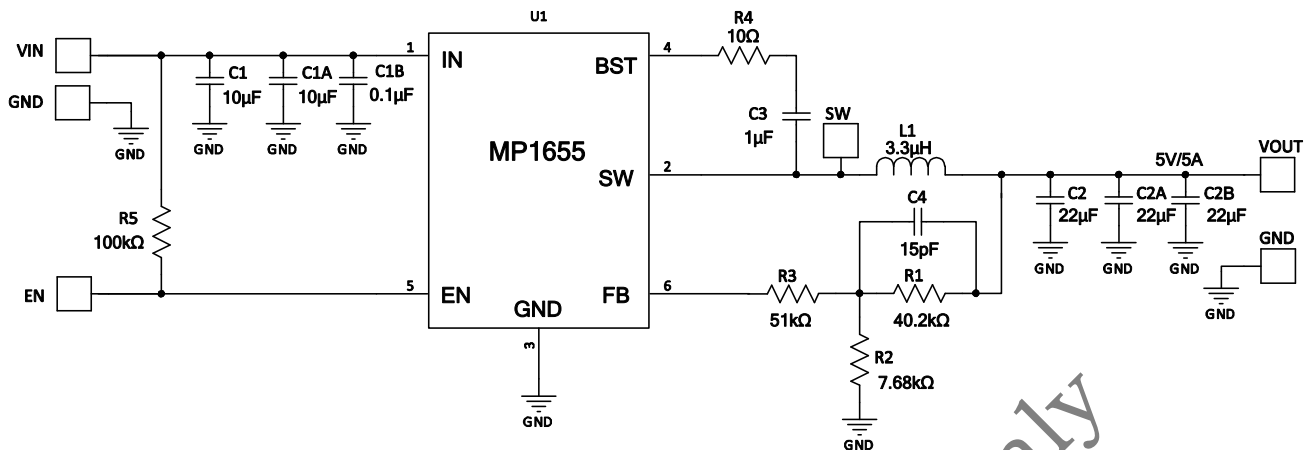
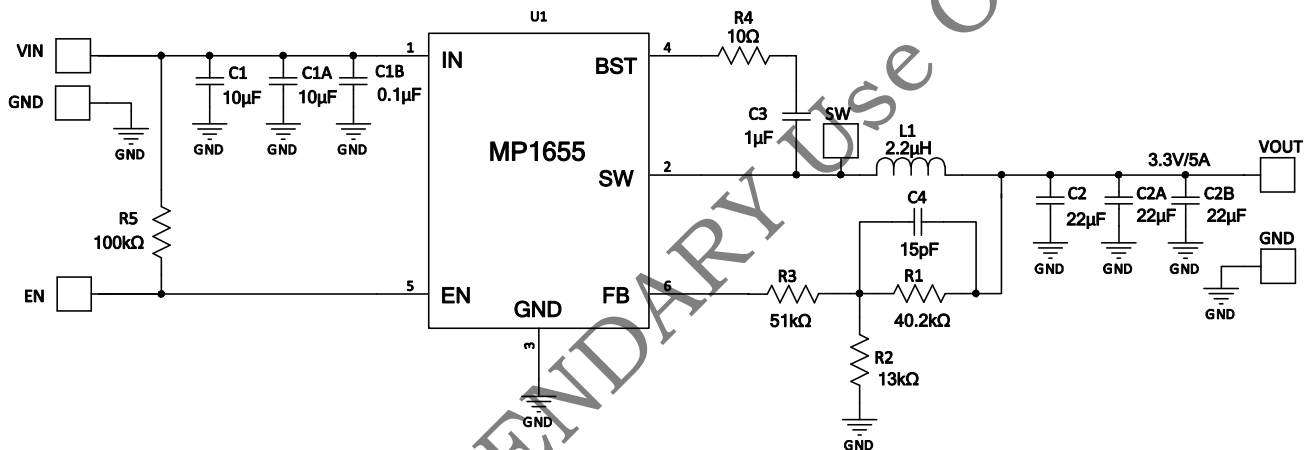
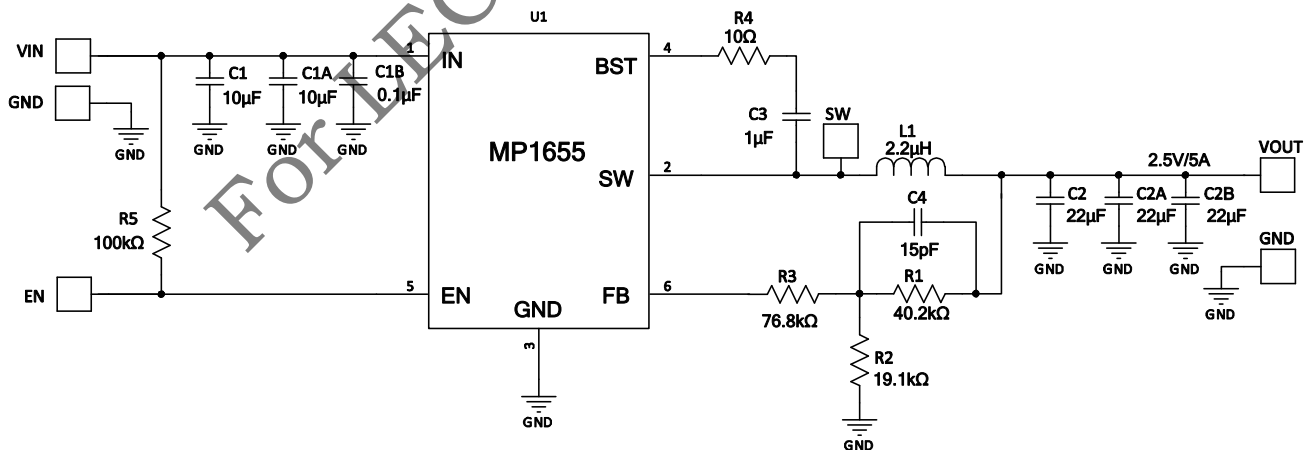
**TYPICAL APPLICATION CIRCUITS**

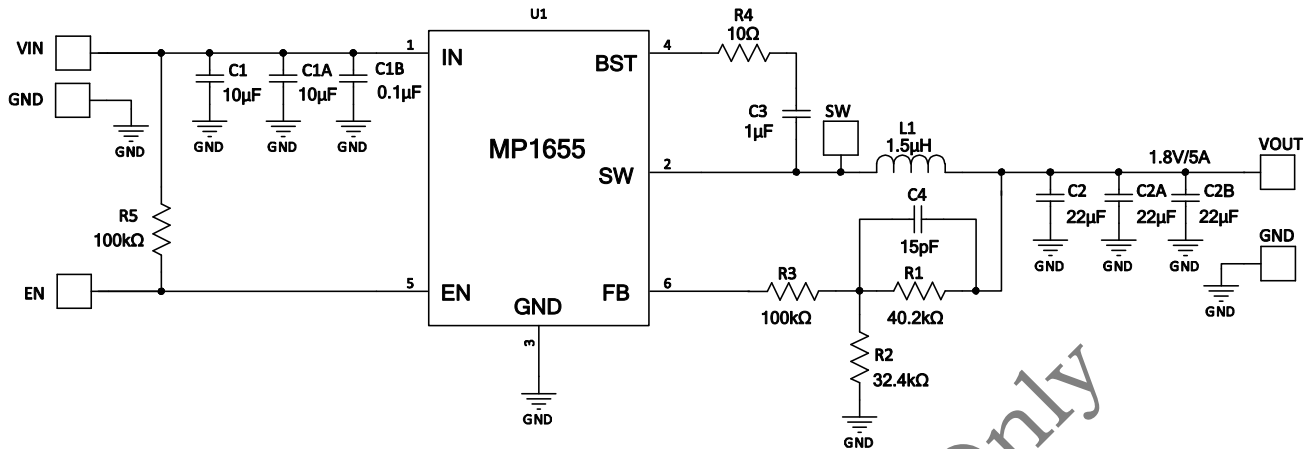
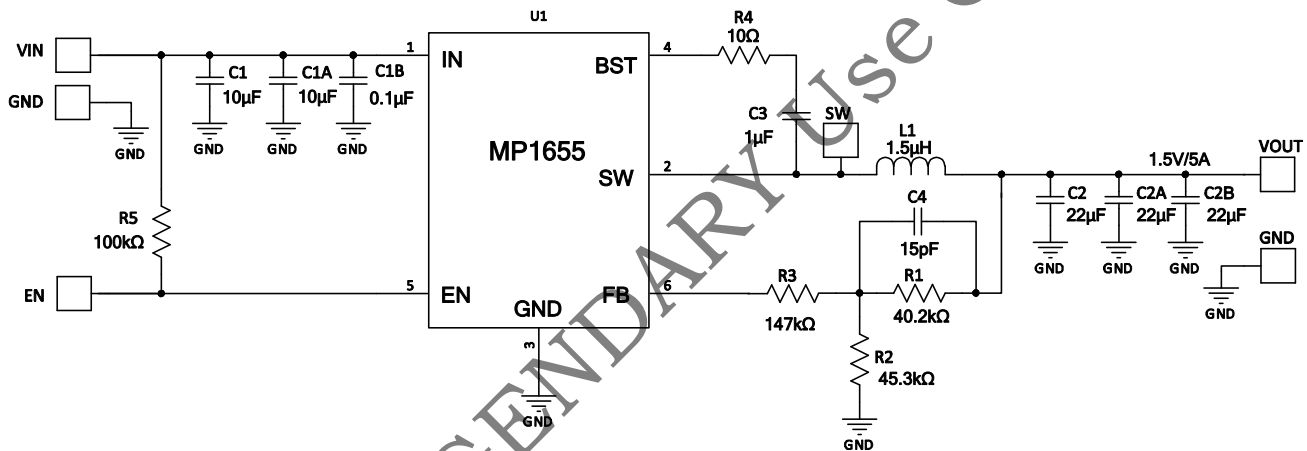
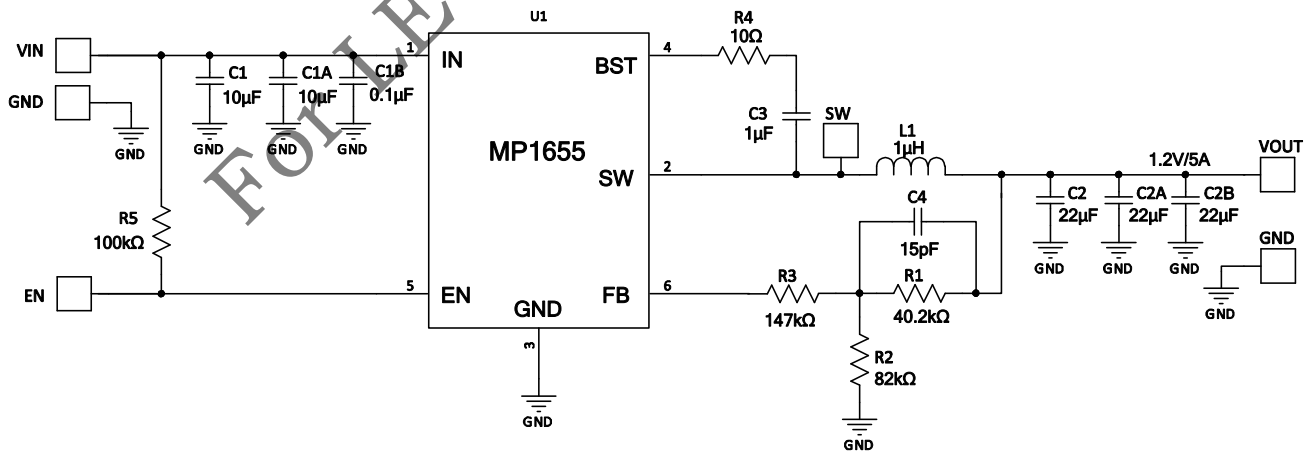
**Figure 6:  $V_{IN} = 12V$ ,  $V_{OUT} = 5V/5A$** 

**Figure 7:  $V_{IN} = 12V$ ,  $V_{OUT} = 3.3V/5A$** 

**Figure 8:  $V_{IN} = 12V$ ,  $V_{OUT} = 2.5V/5A$**

**TYPICAL APPLICATION CIRCUITS (continued)**

**Figure 9:  $V_{IN} = 12V$ ,  $V_{OUT} = 1.8V/5A$** 

**Figure 10:  $V_{IN} = 12V$ ,  $V_{OUT} = 1.5V/5A$** 

**Figure 11:  $V_{IN} = 12V$ ,  $V_{OUT} = 1.2V/5A$**

TYPICAL APPLICATION CIRCUITS (continued)

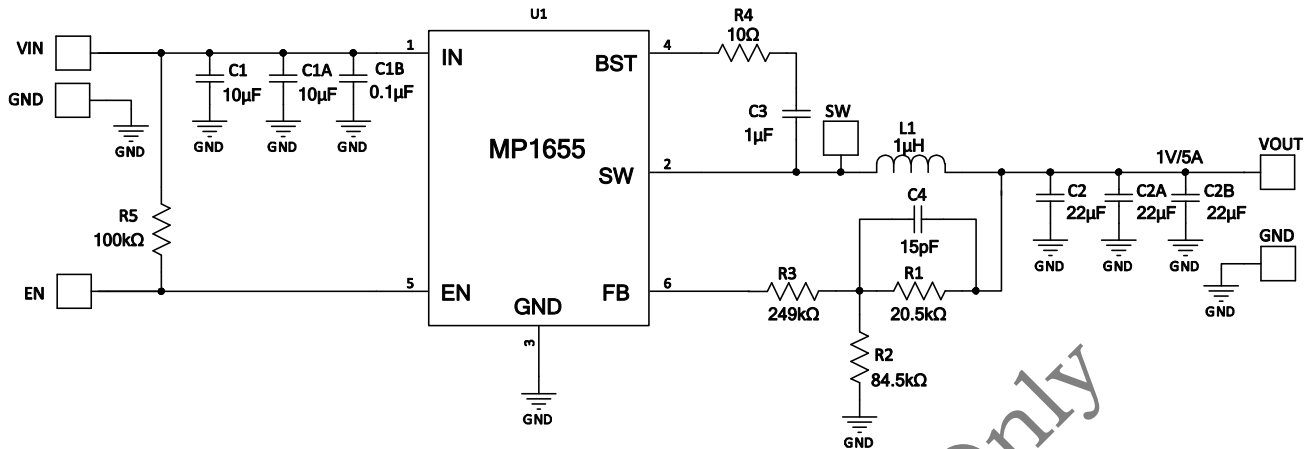
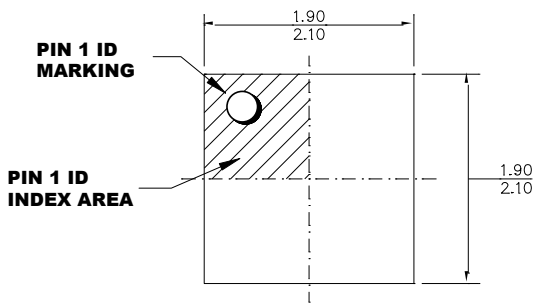

Figure 12:  $V_{IN} = 12V$ ,  $V_{OUT} = 1V/5A$

FOR LEGENDARY Use Only

PACKAGE INFORMATION

QFN-6 (2mmx2mm)



**TOP VIEW**

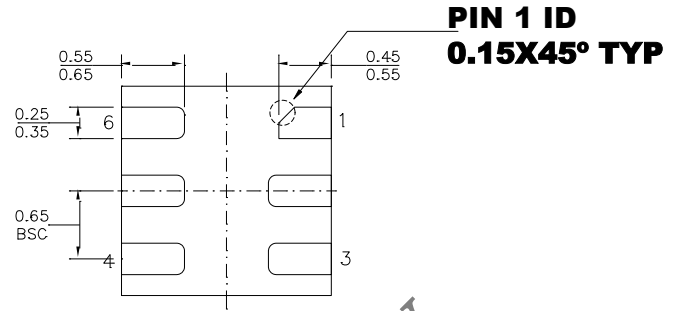

**BOTTOM VIEW**

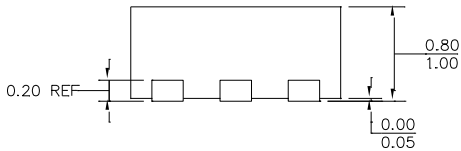

**SIDE VIEW**

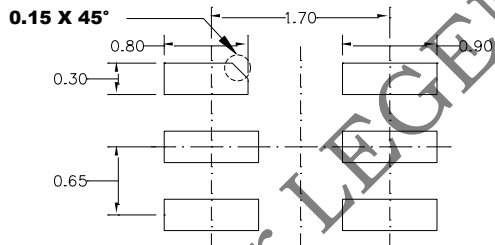

**RECOMMENDED LAND PATTERN**

**NOTE:**

- 1) ALL DIMENSIONS ARE IN MILLIMETERS.
- 2) LEAD COPLANARITY SHALL BE 0.10 MILLIMETERS MAX.
- 3) JEDEC REFERENCE IS MO-220.
- 4) DRAWING IS NOT TO SCALE.

**NOTICE:** The information in this document is subject to change without notice. Users should warrant and guarantee that third party Intellectual Property rights are not infringed upon when integrating MPS products into any application. MPS will not assume any legal responsibility for any said applications.