

FEATURES

- Fast switching-PSEC
- High breakdown voltage
- Low cost - H-P equivalents

ENVIRONMENTAL RATINGS

(Maximum)

Operating Temperature. ----- -65°C to +200°C

Storage Temperature ----- -65°C to +200°C

Power Dissipation @ 25°C ----- 100mW Derate

Linearly to zero at 150°C

Soldering Temperature ----- 230°C for 5 seconds

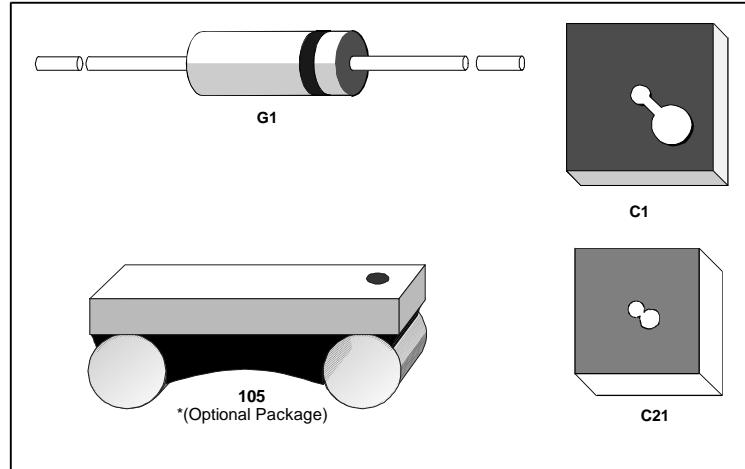

Electrical Specifications @ 25 °C - Single Diodes

PART NUMBER	CASE STYLE	V _B (Min) I _R = 10 ∞A (Volts)	C _T (Max)V f = 1 MHz (pF)	V _F (Max)I I _F = 1 mA (Volts)	F (Min) V _F = 1.0 Volt (mA)	I _R (Max) @		Lifetime(Max) (pSec) (3) I _F = 3mA
						(nA)	(Volts)	
MP 2087	C1	20	1.1	0.41	35	100	15	100
MP 2097	C1	15	1.1	0.41	20	100	8	100
MP 2810	G1	20	1.2	0.41	35	100	15	100
MP 2811	G1	15	1.2	0.41	20	100	8	100
1N5712	G1	20	1.2	0.55	35	100	15	100
1N5713	G1	15	1.2	0.41	20	100	8	100
MP2835	G1	8(1)	1.0	0.34	10(2)	100	1	100
MP2836	C21	8(1)	0.9	0.34	10(2)	100	1	100
MP2800	G1	70	2.0	0.41	15	200	50	100
MP2801	C1	70	1.9	0.41	15	200	50	100
1N5711	G1	70	2.0	0.41	15	200	50	100

High Conductance Diodes

MP2232	G1	15	3.5(1)	.30	150	1000	5	100
MP2233	C1	15	3.5(1)	.30	150	1000	5	100

Note (1) : V_B(min) measured with I_R = 100 μA

Note (2) : I_F(min) measured with V_F = 0.45v

Note (3) : Krakauer method

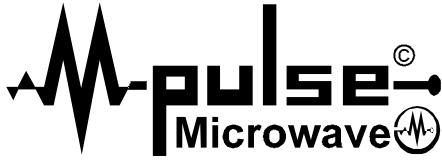

General Purpose Schottky Diodes Applications Data

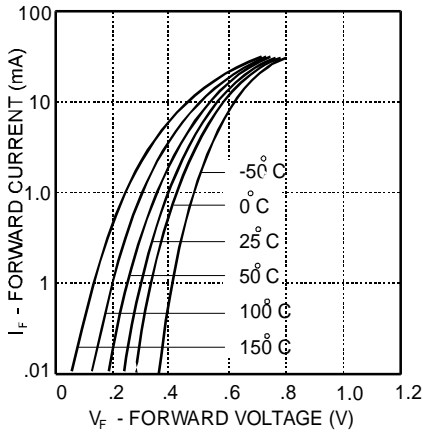

Curve showing typical temperature variation under forward bias conditions for the MP2810 or 1N5712 Schottky Diode

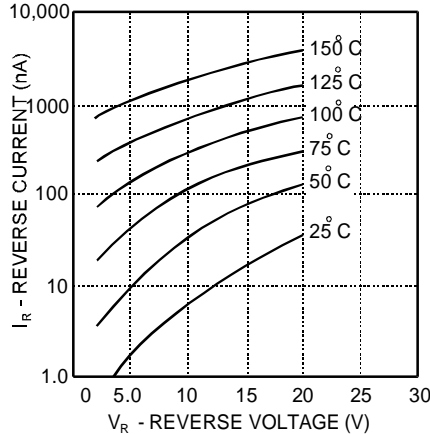

Curve showing typical variation of Reverse Current (I_R) vs. Reverse Voltage (V_R) at various temperatures for the MP2810 or 1N5712 Schottky Diode

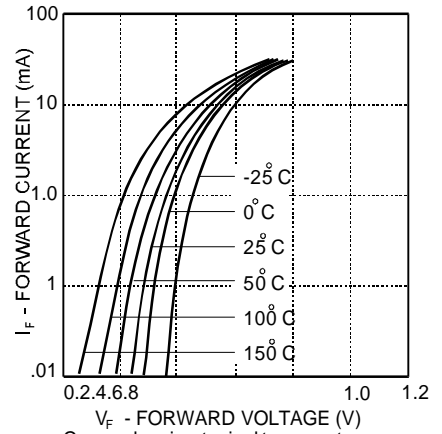

Curve showing typical temperature variation under forward bias conditions for the MP2811 Schottky Diode.

