

DESCRIPTION

The MP3306 is a step-up converter designed for driving white LEDs from 3V to 12V power supply. The MP3306 uses current mode, fixed frequency architecture to regulate the LED current, which is measured through an external high-side current sense resistor. The low 202mV feedback voltage and synchronous rectification reduces power loss and improves efficiency.

The MP3306 is turned off if an over-voltage condition is present due to an open circuit condition. The output disconnect feature allows the output to be completely discharged. The MP3306 includes under-voltage lockout, current limiting, output short protection and thermal overload protection.

The MP3306 is available in small 12-pin QFN (2mm x 2mm) package.

FEATURES

- 3V~12V Input Voltage
- Analog Dimming and PWM Dimming
- Output-to-Input Disconnect in Shutdown Mode
- Programmable Open Load Shutdown
- Output Short Protection
- Low 202mV Feedback Voltage with +/-3% accuracy
- UVLO, Thermal Shutdown
- Available in 2mm x 2mm QFN12 Package

APPLICATIONS

- Smart Phone, MID, PDA
- Digital Still Cameras
- Small LCD Displays

All MPS parts are lead-free, halogen free, and adhere to the RoHS directive. For MPS green status, please visit MPS website under Quality Assurance. "MPS" and "The Future of Analog IC Technology" are Registered Trademarks of Monolithic Power Systems, Inc.

TYPICAL APPLICATION

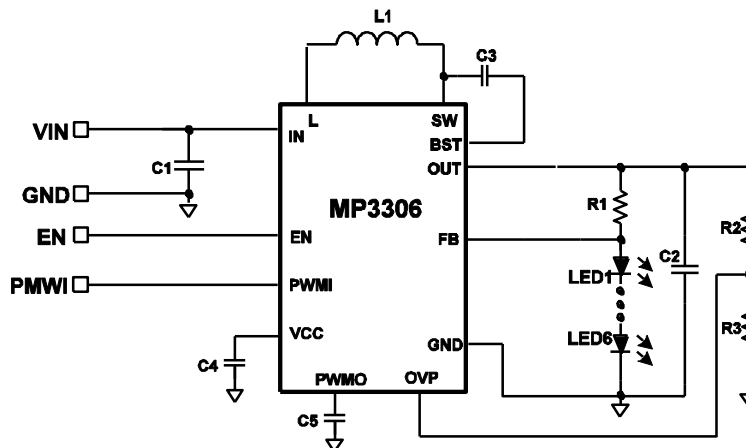

ORDERING INFORMATION

Part Number*	Package	Top Marking
MP3306EG	QFN12 (2x2mm)	3Y

* For Tape & Reel, add suffix -Z (e.g. MP3306EG-Z).
 For RoHS Compliant packaging, add suffix -LF (e.g. MP3306EG-LF-Z)

PACKAGE REFERENCE

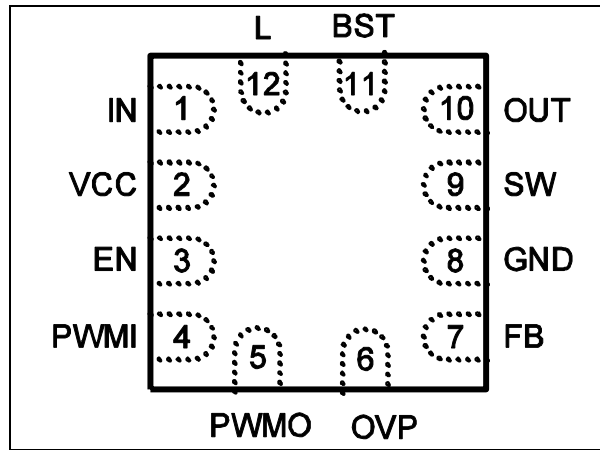

ABSOLUTE MAXIMUM RATINGS ⁽¹⁾

V_{SW}, V_{OUT}, V_{FB}-0.5V to 35V
 V_{BST} $V_{SW} + 6V$
 V_{IN}, V_L -0.5V to 14V
 $V_{EN}, V_{OVP}, V_{PWMI}, V_{PWMO}, V_{CC}$ -0.3V to 6.5V
 Continuous Power Dissipation ($T_A = +25^\circ C$) ⁽²⁾
1.6W
 Storage Temperature..... -55°C to +150°C

Recommended Operating Conditions ⁽³⁾

IN Supply Voltage V_{IN} 3V to 12V
 V_{SW} -0.5V to 30V
 Operating Junct. Temp (T_J)..... -40°C to +125°C

Thermal Resistance ⁽⁴⁾ θ_{JA} θ_{JC}
 QFN12 (2 x 2mm).....80 16 ...°C/W

Notes:

- Exceeding these ratings may damage the device.
- The maximum allowable power dissipation is a function of the maximum junction temperature T_J (MAX), the junction-to-ambient thermal resistance θ_{JA} , and the ambient temperature T_A . The maximum allowable continuous power dissipation at any ambient temperature is calculated by P_D (MAX) = $(T_J$ (MAX)- T_A)/ θ_{JA} . Exceeding the maximum allowable power dissipation will cause excessive die temperature, and the regulator will go into thermal shutdown. Internal thermal shutdown circuitry protects the device from permanent damage.
- The device is not guaranteed to function outside of its operating conditions.
- Measured on JESD51-7, 4-layer PCB.

ELECTRICAL CHARACTERISTICS

$V_{IN} = V_{EN} = 5V$, $T_A = +25^\circ C$, all voltages with respect to GND, unless otherwise noted.

Parameters	Symbol	Condition	Min	Typ	Max	Units
Operating Input Voltage	V_{IN}		3		12	V
VCC Voltage	V_{VCC}	$V_{IN} > 5.5V$, $V_{EN} = 3V$	3.7	3.9	4.1	V
Supply Current (Shutdown)	I_{SD}	$V_{EN} = 0V$		0.1	1	μA
Supply Current (Quiescent)	I_{QS}	$V_{EN} = 5V$, $V_{OUT} - V_{FB} = 0.5V$	300	380	460	μA
Switching Frequency	f_{SW}		550	690	830	kHz
Maximum Duty Cycle	D_{MAX}	$V_{FB} = V_{OUT}$		93		%
Under Voltage Lockout						
IN Under Voltage Lockout	UVLO	V_{IN} Rising	2.5	2.7	2.9	V
Under Voltage Lockout Hysteresis				130		mV
Protection						
OVP Threshold	V_{OVP-TH}		1.18	1.22	1.26	V
SW Current Limit ⁽⁵⁾		Duty Cycle = 60%		1.8		A
Thermal Shutdown ⁽⁵⁾				150		$^\circ C$
Enable						
EN OFF Threshold	V_{ENLO}	V_{EN} Falling	0.6			V
EN ON Threshold	V_{ENHI}	V_{EN} Rising			1.1	V
Dimming						
PWMI Low Threshold	$V_{PWMI-LO}$	V_{PWMI} Falling	0.8			V
PWMI High Threshold	$V_{PWMI-HI}$	V_{PWMI} Rising			1.2	V
PWMI Input Frequency	F_{PWMI}		0.1		50	kHz
Minimum PWMO Dimming Threshold	$V_{PWMO-MIN}$	$V_{FB} = V_{OUT}$		25		mV
Maximum PWMO Dimming Threshold	$V_{PWMO-MAX}$	$V_{OUT} - V_{FB} = 0.2V$		850		mV
Feedback						
FB Voltage	V_{FB}	$V_{EN} = 3V$	196	202	208	mV
FB Input Bias Current	I_{FB}	$V_{EN} = 3V$	3	7	11	μA
Disconnect Switch						
On-Resistance ⁽⁵⁾	R_{ND-ON}			0.5		Ω
Output Switch						
High-Side NMOS On-Resistance ⁽⁵⁾	R_{NH-ON}			0.6		Ω
Low-Side NMOS On-Resistance ⁽⁵⁾	R_{NL-ON}			0.6		Ω

Notes:

5) Guaranteed by design

PIN FUNCTIONS

Pin #	Name	Pin Function
1	IN	Input Supply Pin. It provides the power for internal driver and logic circuit. Must be locally bypassed.
2	VCC	The Internal Linear Regulator Output. VCC provides power supply for the internal MOSFET switch gate driver and the internal control circuitry .Bypass VCC to GND with a ceramic capacitor.
3	EN	EN Control Input. A voltage greater than 1.1V turns the part on and less than 0.6V turns the part off.
4	PWMI	Apply a PWM signal on this pin for brightness control. This signal is uniformed and filtered at PWMO pin with an internal 100kΩ resistance. With a capacitor at PWMO pin, the duty cycle from 0% to 100% at PWMI pin is converted to 0V to 1.2V DC voltage at PWMO pin.
5	PWMO	PWM Filter Output. Connect a capacitor from PWMO to GND. The voltage on this pin range 0V to 1.2V linearly controls the feedback voltage from 0V to 0.2V. To use PWM dimming, connect the PWM input signal to PWMI pin. To use analog dimming, connect the analog input voltage to PWMO pin.
6	OVP	Over Voltage Protection Pin. Use one external resistor voltage divider to program OVP threshold. When the OVP pin voltage reaches the shutdown threshold 1.22V, the IC will be turned off and latch up until EN is toggled again.
7	FB	Feedback Input. The MP3306 regulates the voltage across the current sense resistor between FB and VOUT. Connect a current sense resistor from VOUT to the LED string. Connect the anode of the LED string to FB. The regulation voltage is 202mV.
8	GND	Ground.
9	SW	Power Switch Node. SW is the drain of the internal low side MOSFET switch. Connect the power inductor to SW.
10	OUT	The OUTPUT terminal. Connect the output cap on this pin, the output capacitor must be ceramic type and be placed as short as possible between OUT pin and GND pin.
11	BST	Bootstrap. A capacitor is connected between SW and BST pins to form a floating supply to drive the high side MOSFET.
12	L	Power input pin. L is the source of internal disconnection MOSFET. Connect the inductor to this pin.

TYPICAL PERFORMANCE CHARACTERISTICS
 $V_{IN}=5V$, $V_{EN}=5V$, 8 LEDs in series, 20mA, unless otherwise noted.

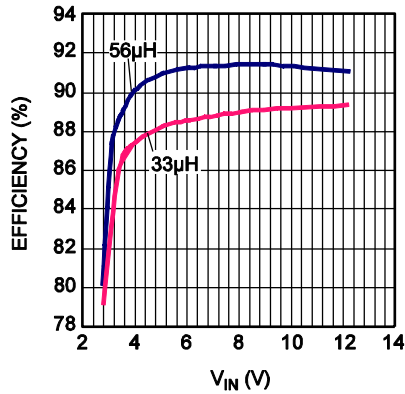
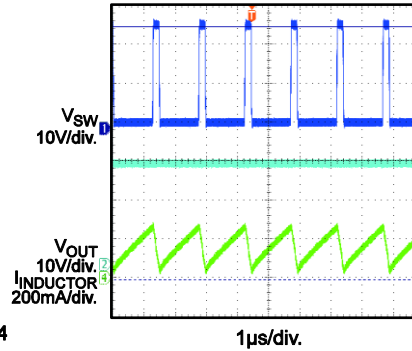
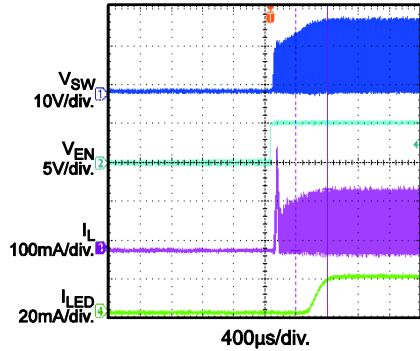
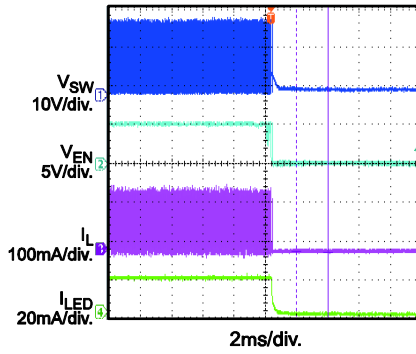
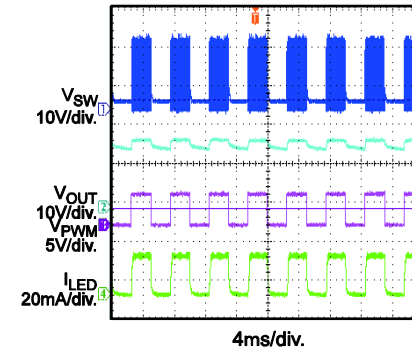
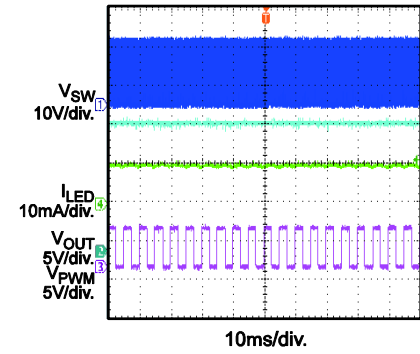
Efficiency

Steady State
 $V_{IN} = 3V$

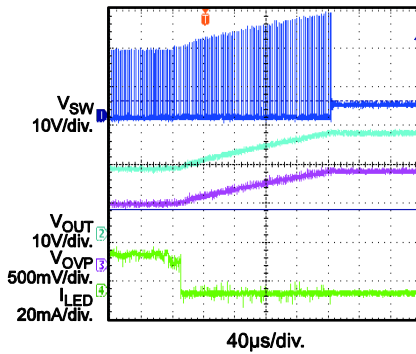
EN Startup

EN Shutdown

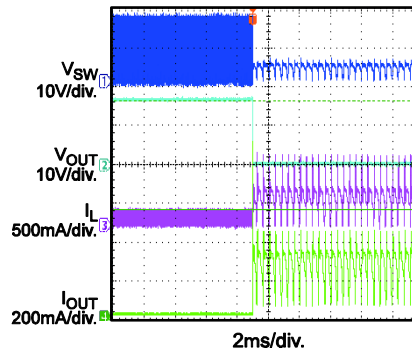
PWM Dimming
 $f_{PWM} = 200Hz$, $D = 50\%$

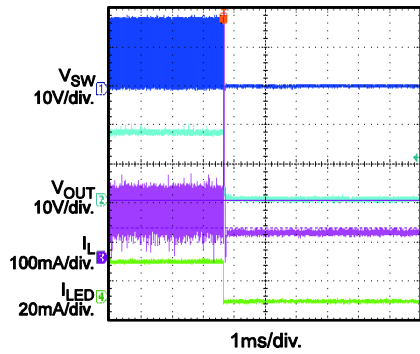
Analog Dimming
 $f_{PWM} = 200Hz$, $C_{PWMO} = 470nF$, $D = 50\%$

Open LED Protection

Open LED @ Working

Short LED Protection

Short LED+ to LED-

Short VOUT to GND Protection

 Short V_{OUT} to GND

FUNCTION DIAGRAM

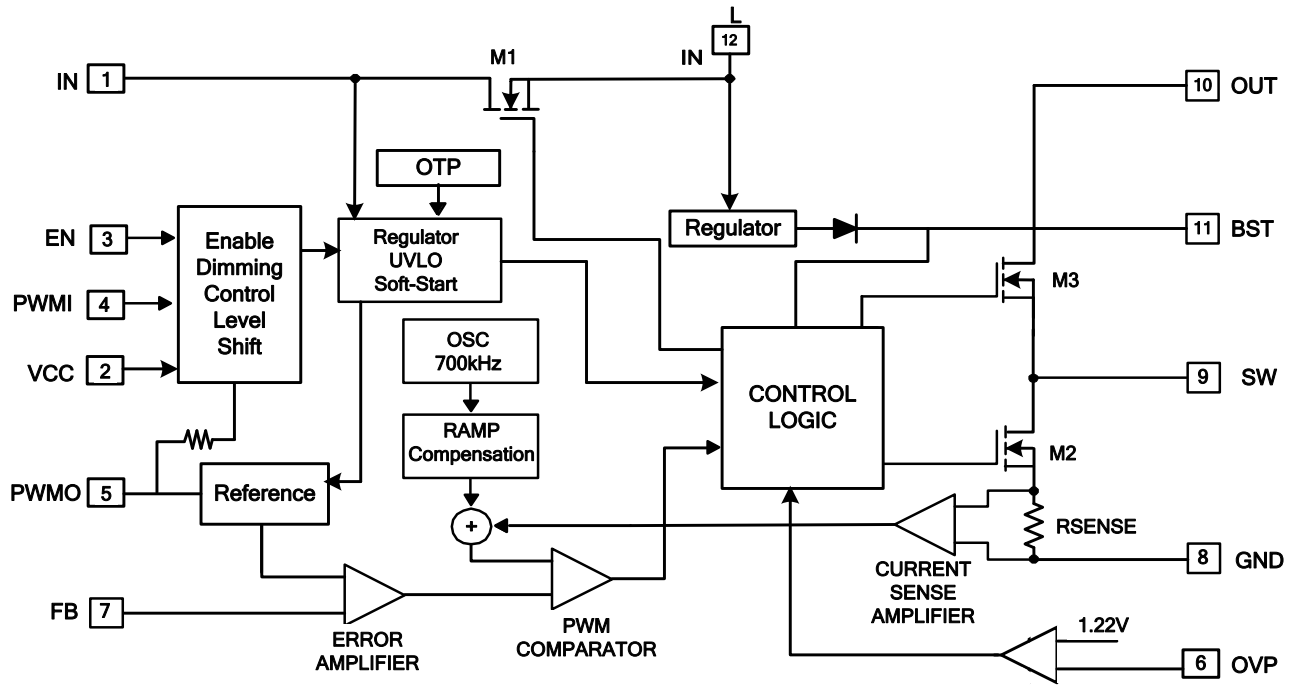

Figure 1—Functional Block Diagram

OPERATION

The MP3306 uses a constant frequency, peak current mode step up regulator architecture to regulate the current flowing through series string of white LEDs. The operation of the MP3306 can be understood by referring to the block diagram of Figure 1.

At the start of each oscillator cycle the low side FET (M2) is turned on through the control circuitry. To prevent sub-harmonic oscillations at duty cycles greater than 50 percent, a stabilizing ramp is added to the output of the current sense amplifier and the result is fed into the positive input of the PWM comparator. When this voltage equals the output voltage of the error amplifier the power FET is turned off. Then the inductor current flows into the output capacitor and LED load through internal high side N-channel MOSFET (M3), which forces the inductor current to decrease.

The voltage at the output of the error amplifier is an amplified version of the difference between the 200mV reference voltage and the feedback voltage. In this way the LED current is regulated accurately.

If the feedback voltage starts to drop, the output of the error amplifier increases. This result in more current flowing through the high side power FET,

thus increasing the power charged in inductor and delivered to the output.

MP3306 provides the analog and PWM dimming solution, the internal resistor and external capacitor one PWMO pin filters the PWM dimming signal on PWMI pin to DC level that program the internal reference to accomplish the analog dimming function. When floating the PWMO pin, PWM dimming function works.

Open Load protection shuts off the MP3306 if the output voltage goes too high. In some cases an LED may fail, this results in the feedback voltage always being zero. The part then runs at maximum duty cycle boosting the output voltage up. If the output ever exceeds the programmable OVP threshold, the MP3306 will shut down. The part does not switch again until the EN pin or V_{IN} is toggled.

During Shutdown mode when EN is low, the IC keeps the internal high-side N-channel MOSFET (M1) off to disconnect the output from input.

MP3306 has cycle by cycle current limit to protect the load and IC from over current. And the internal MOSFET (M1) limits the input current to prevent system damage when short V_{OUT} condition occurs.

APPLICATION INFORMATION

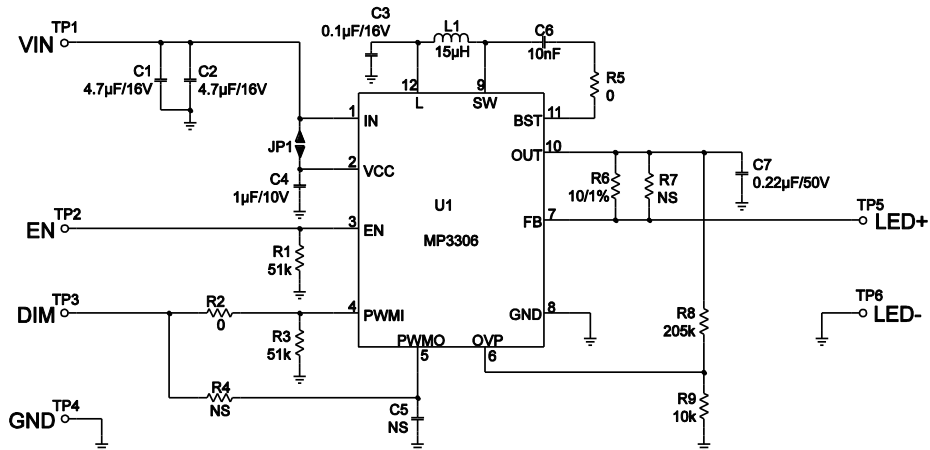

Figure 2—3V~12V Input, Typical Application Driving 8 WLEDs in series

Figure 2 shows a typical application circuit that can drive up to 8 white LEDs with 20mA. A 0.22~2.2µF output capacitor is sufficient for most applications. The inductor with low DC inductor resistance (DCR) will improve efficiency. Two 4.7µF ceramic capacitors provide sufficient input decoupling.

Selecting the Inductor

The inductor forces a higher output voltage driven from a lower input voltage. A larger inductor value results in less ripple current, a lower peak inductor current, and reduces stress on the internal N-Channel MOSFET. However, larger-value inductor has a larger physical footprint, higher series resistance, and lower saturation current.

Choose an inductor that does not saturate under the worst-case load conditions. Calculate the required inductance value using the following equations:

$$L \geq \frac{\eta \times V_{OUT} \times D \times (1-D)^2}{2 \times f_{SW} \times I_{LOAD}}$$

$$D = 1 - \frac{V_{IN}}{V_{OUT}}$$

Where V_{IN} and V_{OUT} are the input and output voltages, f_{SW} is the switching frequency, I_{LOAD} is the LED load current, and η is the efficiency.

Setting the LED Current

The LED current is controlled by the current setting resistor, R1. The current through the LEDs is given by: $I_{LED} = 202mV/R1$.

Table 1 shows the selection of resistors for a given LED current.

Table 1— I_{LED} vs. R1 RSET

I_{LED} (mA)	R1 (Ω)
1	200
5	40
10	20
20	10
60	3.33
180	1.11
200	1

The internal ramped compensation voltage added to the current sense amplifier reduces the maximum output current as the duty cycle increases. As more LEDs are added, the output voltage rises but the maximum current delivered to the load falls as well. Figure 3 shows the current limit curve, and the max LED current is gotten as the formula.

$$I_{LOAD(max)} = \left(I_{PK} - \frac{V_{IN} \times D}{2 \times L \times f_{SW}} \right) \times (1-D) \times 0.8$$

Where, I_{PK} is the peak current corresponding duty cycle from current limit curve, the L is inductor, the 0.8 means the margin coefficient.

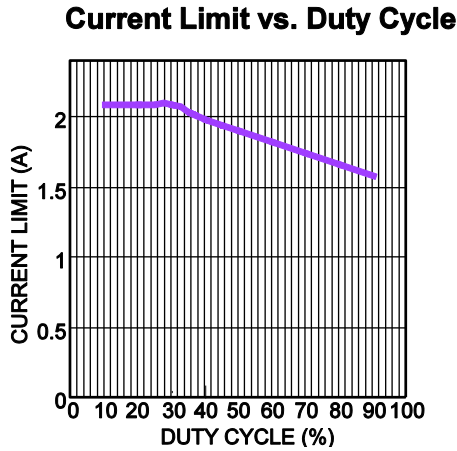

Figure 3—Current Limit Curve

Analog and PWM Dimming

MP3306 provides 2 types of dimming solutions, analog dimming and PWM dimming.

For analog, connect an external capacitor on PWMO pin to form the low pass filter with internal resistor R, the PWM dimming signal on PWMI pin is filtered to DC signal to set the internal reference to accomplish the analog dimming. The time constant should be ten times greater than a PWM waveform cycle:

$$RC > 10 \cdot T_{PWM}$$

For PWM dimming, floating PWMO pin and apply the PWM dimming signal on PWMI pin.

Setting Over Voltage Protection Threshold

Open Load protection will shut off the MP3306 if the output voltage goes too high. In some cases an LED may fail, this will result in the feedback voltage always being zero. The part boots the output voltage higher and higher. If the output voltage ever exceeds the programmed OVP threshold as the formula,

$$V_{OVP} = 1.22 \times (1 + R2/R3)$$

The MP3306 will shut down. The part will not switch again until the power is recycled.

Layout Considerations

Careful attention must be paid to the PCB board layout and components placement. Proper layout of the high frequency switching path is critical to prevent noise and electromagnetic interference problems. The loop of MP3306's internal low side MOSFET, synchronous MOSFET, and output capacitor is flowing with high frequency ripple current, it must be minimized. So the output capacitor should be placed to IC as close as possible.

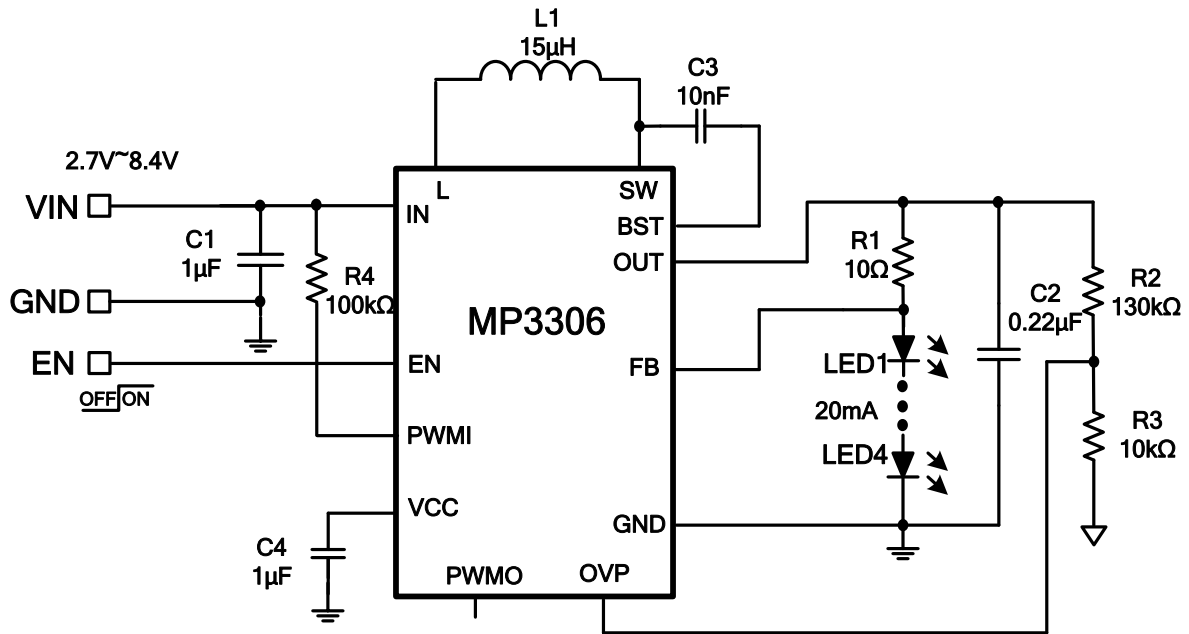
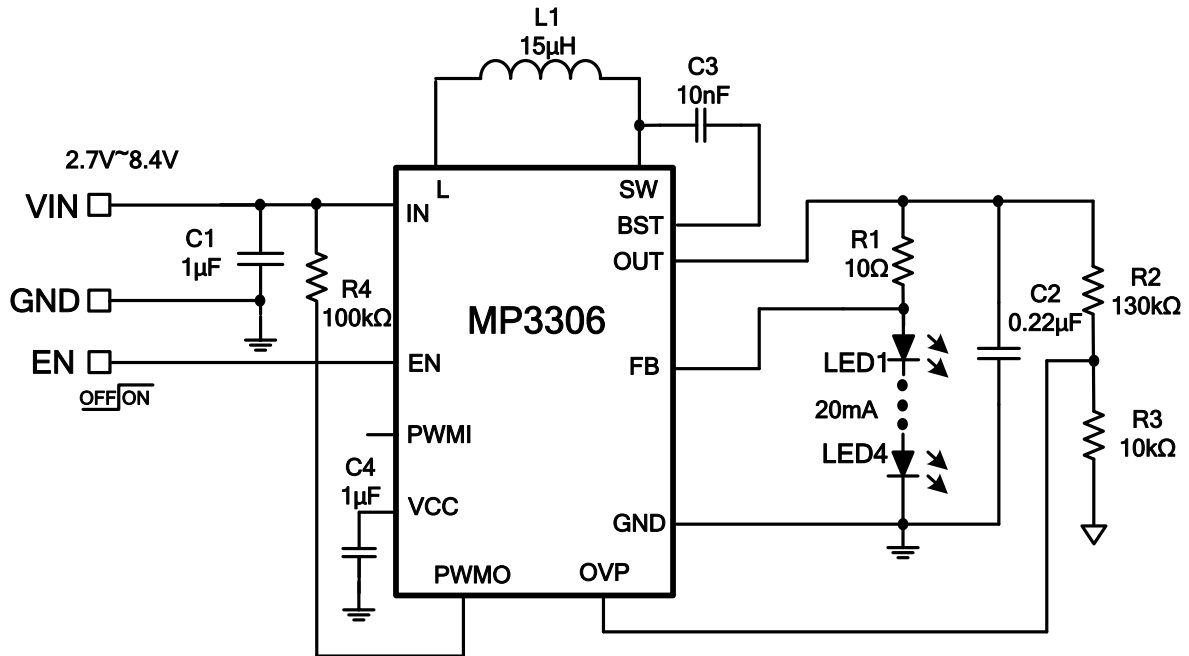
TYPICAL APPLICATION CIRCUIT

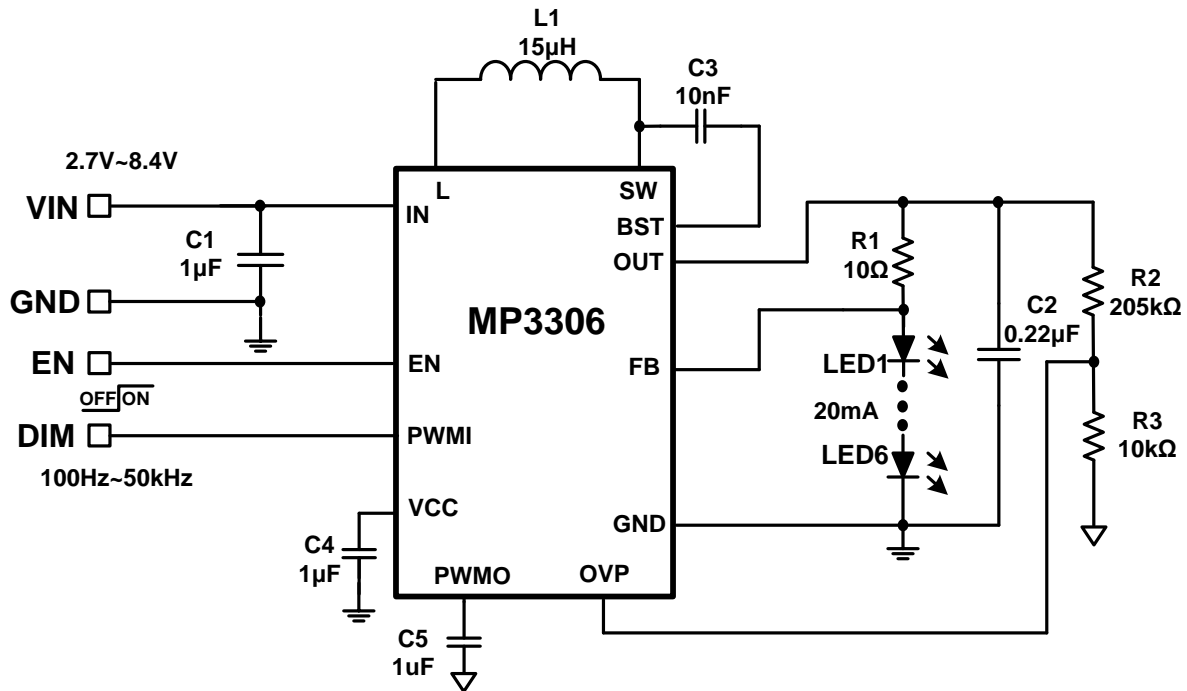
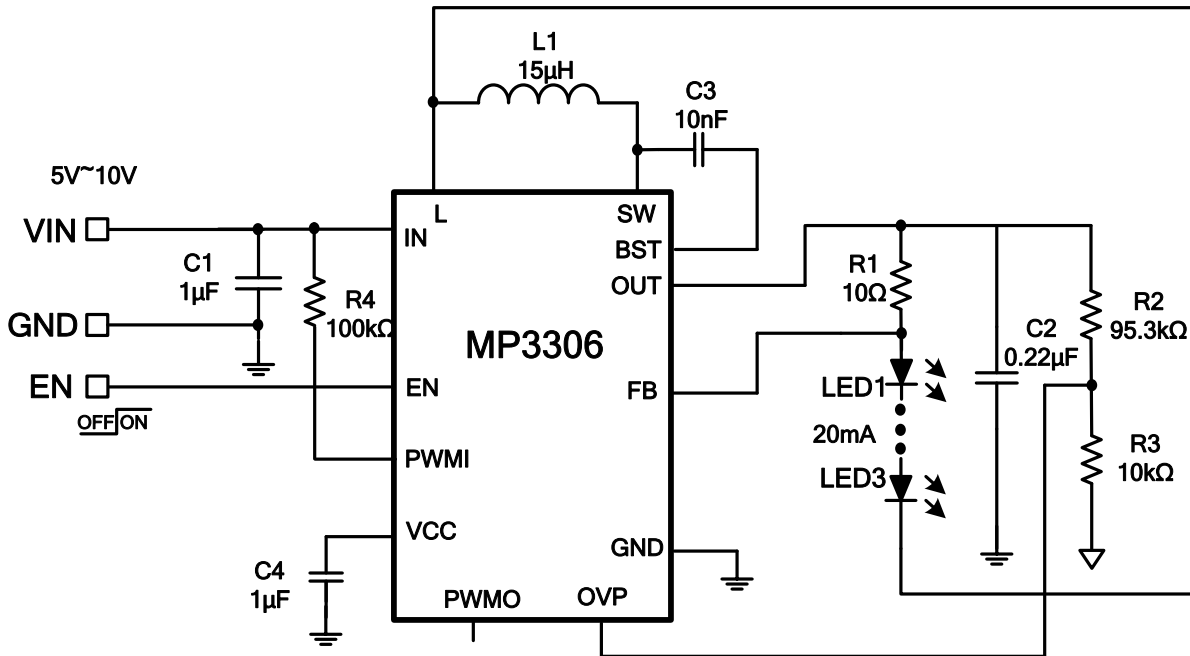
Figure 4— 4 LEDs in Series 20mA

Figure 5— 4 LEDs in Series 20mA

Figure 6— 6 LEDs in Series with PWM Dimming

Figure 7— 3 LEDs in Series 20mA with 5~10V Input Voltage

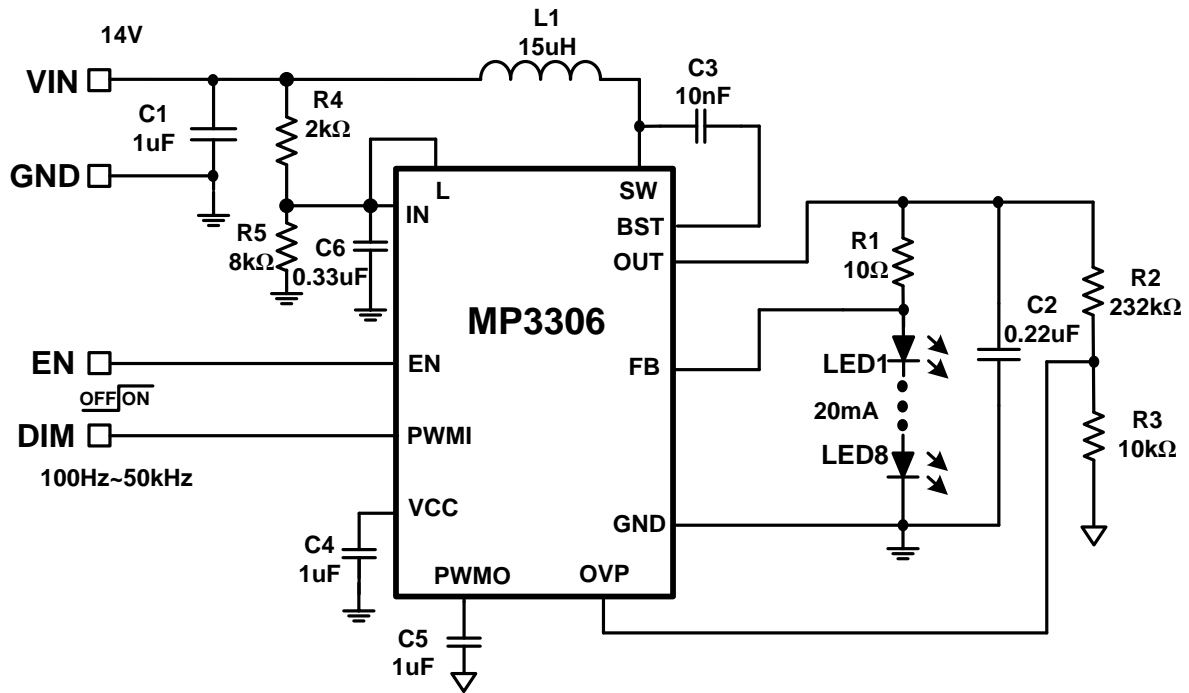
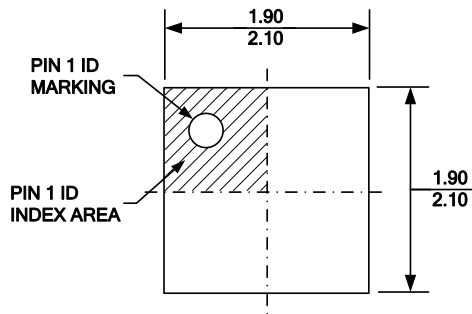

Figure 8— The application when $V_{in} > 12V$

PACKAGE INFORMATION

QFN12 (2x2mm)



TOP VIEW

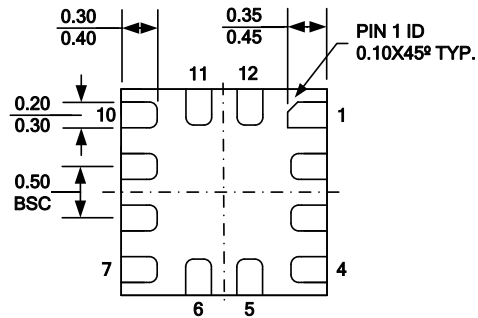

BOTTOM VIEW

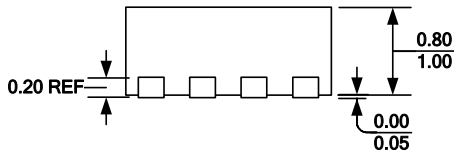

SIDE VIEW

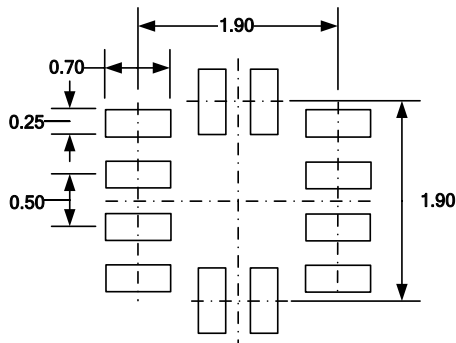

RECOMMENDED LAND PATTERN

NOTE:

- 1) ALL DIMENSIONS ARE IN MILLIMETERS.
- 2) EXPOSED PADDLE SIZE DOES NOT INCLUDE MOLD FLASH.
- 3) LEAD COPLANARITY SHALL BE 0.10 MILLIMETER MAX.
- 4) JEDEC REFERENCE IS MO-220, VARIATION VCCD.
- 5) DRAWING IS NOT TO SCALE.

NOTICE: The information in this document is subject to change without notice. Users should warrant and guarantee that third party Intellectual Property rights are not infringed upon when integrating MPS products into any application. MPS will not assume any legal responsibility for any said applications.