

### FEATURES

- Precision 7–Bit Plus Sign ADC
- 8 Channel Analog Mux
- Single Reference to GND
- Input Referenced to User Supplied  $V_{MID}$
- $DNL = \pm 1/2 \text{ LSB}$ ,  $INL = \pm 1 \text{ LSB}$
- Single Supply: 5 V
- ESD Protection: 2000 V

### APPLICATIONS

- Servo Control
- Low Cost Audio Control
- Voice Acquisition

### GENERAL DESCRIPTION

The MP8820 is a precision 1.6 MHz sampling 7-bit plus sign Analog-to-Digital Converter with an eight channel input mux and  $\mu\text{P}$  interface. The device has internal circuitry which receives the user supplied reference voltages  $V_{REF(+)}$  and  $V_{REF(-)}$ , and generates the ADC reference voltages  $V_{MID} \pm (V_{REF(+)} - V_{REF(-)})$ . Since  $V_{REF(+)}$  is internally buffered and  $V_{REF(-)}$  is generally ground, this structure allows the user to easily generate an input range biased about a user-supplied  $V_{MID}$  from a grounded reference source.

The internal ADC reference voltages are capable of swinging

to within 0.5 V of the supply rails, giving the MP8820 a wide range over which the effective channel gain can be adjusted.

The MP8820 uses a two-step flash conversion technique. The first section determines the sign and the 3 MSBs while the second segment converts the 4 LSBs. The ADC conversion begins when  $\overline{WR}$  goes low and the data is valid 500 ns after the rising edge of  $\overline{WR}$ . The MP8820 operates from a single 5V supply and consumes only 175mW of power.

Specified for operation over the industrial ( $-40$  to  $+85^\circ\text{C}$ ) temperature range, the MP8820 is available in Surface Mount (SOIC) and Shrunk Small Outline (SSOP) packages.

### SIMPLIFIED BLOCK DIAGRAM

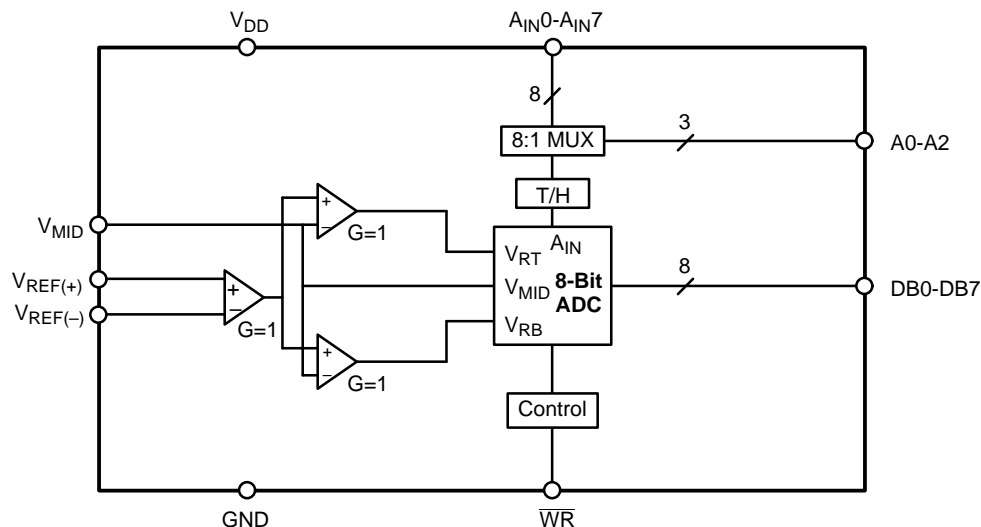

## ORDERING INFORMATION

Package Type	Temperature Range	Part No.
SOIC	-40 to +85°C	MP8820AS
SSOP	-40 to +85°C	MP8820AQ

## PIN CONFIGURATIONS

See Packaging Section for Package Dimensions

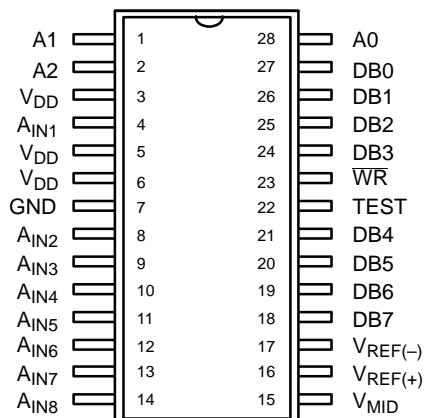

**28 Pin SOIC (0.300") – S28**  
**28 Pin SSOP – A28**

## PIN OUT DEFINITIONS

PIN NO.	NAME	DESCRIPTION
1	A1	Analog Input Mux Address Bit 1
2	A2	Analog Input Mux Address Bit 2
3	V <sub>DD</sub>	Positive Power Supply (5 V)
4	A <sub>IN0</sub>	Analog Input 0
5	V <sub>DD</sub>	Positive Power Supply (5 V)
6	V <sub>DD</sub>	Positive Power Supply (5 V)
7	GND	Negative power supplies (0V)
8	A <sub>IN1</sub>	Analog Input 1
9	A <sub>IN2</sub>	Analog Input 2
10	A <sub>IN3</sub>	Analog Input 3
11	A <sub>IN4</sub>	Analog Input 4
12	A <sub>IN5</sub>	Analog Input 5
13	A <sub>IN6</sub>	Analog Input 6
14	A <sub>IN7</sub>	Analog Input 7
15	V <sub>MID</sub>	System Reference

PIN NO.	NAME	DESCRIPTION
16	V <sub>REF(+)</sub>	Reference Voltage + Input Terminal
17	V <sub>REF(-)</sub>	Reference Voltage – Input Terminal.
18	DB7 (MSB)	Data Output Bit 7
19	DB6	Data Output Bit 6
20	DB5	Data Output Bit 5
21	DB4	Data Output Bit 4
22	TEST	Test Mode Pin
23	WR	Sample Window Control
24	DB3	Data Output Bit 3
25	DB2	Data Output Bit 2
26	DB1	Data Output Bit 1
27	DB0	Data Output Bit 0
28	A0	Analog Input Mux Address Bit 0

## ELECTRICAL CHARACTERISTICS TABLE FOR DUAL SUPPLIES

Unless Otherwise Noted:  $V_{DD} = 5\text{ V}$ ,  $GND = 0\text{ V}$ ,  $V_{REF(+)} = 1.5\text{ V}$ ,  $V_{REF(-)} = 0\text{ V}$ ,  $V_{MID} = 2.5\text{ V}$ .

Parameter	Symbol	25°C			Units	Test Conditions/Comments
		Min	Typ	Max		
<b>DC CHARACTERISTICS</b>						
Resolution	N	8			Bits	
Differential Non-Linearity	DNL	-1	±1/4	1	LSB	
Differential Non-Linearity <sup>2</sup>	DNL	-1	±1/2	1	LSB	@ $V_{REF(+)} - V_{REF(-)} = 0.5\text{ V}$
Integral Non-Linearity <sup>7</sup>	INL	-1	±1/2	1	LSB	
Integral Non-Linearity <sup>4, 7</sup>	INL	-1	±1/2	1	LSB	@ $V_{REF(+)} - V_{REF(-)} = 0.5\text{ V}$
Monotonicity		Guaranteed				
Bipolar Zero Error	BZE	-25	10	25	mV	Offset is measured as the bipolar zero code transition, 01111111 to 10000000, relative to $V_{MID}$
Zero Scale Drift <sup>2, 5</sup>	ZSD			50	μV/°C	
Full Scale Error					%FS	This is a measure of the internal reference translation. Ideally
$V_{MID}$ to $V_{RT}$	+FSE	-5.0	2.5	5.0		$V_{RT} - V_{MID} = V_{MID} - V_{RB} =$
$V_{MID}$ to $V_{RB}$	-FSE	-5.0	2.5	5.0		$V_{REF(+)} - V_{REF(-)}$
Full Scale Drift <sup>2, 6</sup>	FSD		0.025		%FS/°C	
DC Input Range <sup>1</sup>	$V_{INP-P}$	1		3	V <sub>pp</sub>	The analog input is specified as V <sub>pp</sub> centered around $V_{MID}$
Aperture Delay	t <sub>AP</sub>		50		ns	From rising edge of $\overline{WR}$
Input Capacitance	C <sub>IN</sub>		25		pF	Measured with $V_{IN} - DC = 2.5\text{ V}$ and $\overline{WR} = \text{low}$
<b>REFERENCE VOLTAGES</b>						
Positive Reference Input Voltage	$V_{REF(+)}$	0.5		1.5	V	Reference voltage with respect to $V_{REF(-)}$
$V_{REF(+)}$ Input Resistance	R <sub>V<sub>REF+</sub></sub>		1		MΩ	
Internal Reference Settling Time	V <sub>R<sub>STL</sub></sub>		500		ns	Settling time required for ADC to make a proper conversion after ( $V_{REF(+)} - V_{REF(-)}$ ) has changed
Negative Reference Input Voltage	$V_{REF(-)}$	0		$V_{REF(+)} - 0.5$	V	
$V_{REF(-)}$ Input Resistance	R <sub>V<sub>REF-</sub></sub>		1		KΩ	
$V_{MID}$ Input Current	I <sub>VM</sub>		0		mA	
$V_{MID}$ Range	$V_{MID}$	2	2.5	3	V	$V_{MID} \leq V_{DD} - 0.5 - [V_{REF(+)} - V_{REF(-)}]$ $V_{MID} \leq V_{SS} + 0.5 + [V_{REF(-)} - V_{REF(+)}]$
<b>POWER SUPPLIES</b>						
Positive Supply	$V_{DD}$	4.75	5	5.25	V	
Negative Supply	GND	0	0	0	V	
Power Supply Rejection Ratio <sup>2</sup>	PSRR			-48	dB	f = 1 kHz. Not tested.
Supply Current	I <sub>DD</sub>			45	mA	
<b>DIGITAL CHARACTERISTICS<sup>3, 4</sup></b>						
Digital Input High Voltage	$V_{IH}$	4			V	
Digital Input Low Voltage	$V_{IL}$			1	V	

## ELECTRICAL CHARACTERISTICS TABLE

Description	Symbol	25°C			Units	Conditions
		Min	Typ	Max		
<b>DIGITAL CHARACTERISTICS (CONT'D)</b>						
V <sub>OL</sub>	V <sub>OL</sub>			0.5	V	@ I <sub>OL</sub> = 1 mA
V <sub>OH</sub>	V <sub>OH</sub>	4.5				@ I <sub>OH</sub> = 1 mA
I <sub>IN-Dig</sub>	I <sub>DL</sub>	-50		50	μA	
3-State Leakage	I <sub>LK</sub>	-50		50	μA	
Digital Timing Specifications						
Write time (analog input tracking)	t <sub>WR</sub>	150			ns	For testing, rise time = fall time = 10 ns. Output loading = 50 pF.
Conversion Time	t <sub>CONV</sub>		500		ns	
Input mux set-up time	t <sub>MSU</sub>	150			ns	
Input mux hold time	t <sub>MH</sub>	50			ns	

### NOTES

- 1 Maximum input voltage is 1 V less than V<sub>DD</sub>.
- 2 Guaranteed but not production tested.
- 3 Digital input levels should not go below ground or exceed the positive supply voltage, otherwise damage may occur.
- 4 See timing diagram.
- 5 Measured as the change in the bipolar zero error over temperature. This error does not include the error introduced by the external reference drift.
- 6 This error does not include the error introduced by the external reference drift.
- 7 INL is measured as a 7-bit +sign ADC with 8-bit resolution.

**Specifications are subject to change without notice**

### ABSOLUTE MAXIMUM RATINGS (T<sub>A</sub> = +25°C unless otherwise noted)<sup>1, 2</sup>

V <sub>DD</sub> to GND	6 V	ESD Rating	2000 V
All Digital Inputs	V <sub>DD</sub> +0.5 V to GND -0.5 V	Package Power Dissipation Rating @ 75°C	
Storage Temperature	-65 to 150°C	SSOP, SOIC	1000mW
Lead Temperature (Soldering 10 seconds)	+300°C	Derates above 75°C	6mW/°C

### NOTES:

- 1 Stresses above those listed under "Absolute Maximum Ratings" may cause permanent damage to the device. This is a stress rating only and functional operation at or above this specification is not implied. Exposure to maximum rating conditions for extended periods may affect device reliability.
- 2 Any input pin which can see a value outside the absolute maximum ratings should be protected by Schottky diode clamps (HP5082-2835) from input pin to the supplies. *All inputs have protection diodes* which will protect the device from short transients outside the supplies of less than 100mA for less than 100μs.

**THEORY OF OPERATION**

The defining feature of the MP8820 is that it digitizes a bipolar input signal centered around a given voltage,  $V_{MID}$ . The peak to peak swing of  $A_{IN}$  is defined by the two input reference voltages,  $V_{REF(+)}$  and  $V_{REF(-)}$ .

The MP8820 takes in the center voltage and the two refer-

ence voltages and moves the resistor ladder endpoints  $V_{RT}$  and  $V_{RB}$  of the ADC around  $V_{MID}$  by  $\pm(V_{REF(+)} - V_{REF(-)})$ . In this way, a unipolar to bipolar translation can take place without having to use both a positive and negative supply. The center voltage acts as a bipolar zero and signals that moves below it are considered negative and signals that exceed it are taken to be positive. The block diagram is shown in *Figure 1*.

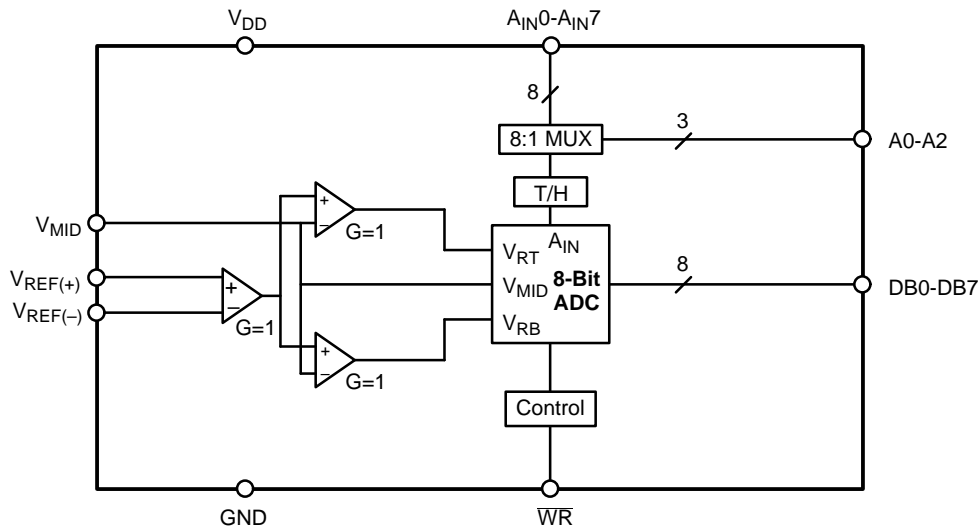

**Figure 1. MP8820 Block Diagram**

Unlike a unipolar system where one end of the ADC's resistor ladder is modulated above an offset voltage, both ends of the MP8820's reference chain expand or contract around a fixed  $V_{MID}$ . The maximum positive full scale voltage is  $V_{RT} = V_{MID} + (V_{REF(+)} - V_{REF(-)})$ . The maximum negative full scale voltage is  $V_{RB} = V_{MID} - (V_{REF(+)} - V_{REF(-)})$ . This type of translation is particularly useful in single supply applications where the input is centered about user specified  $V_{MID}$ .

The ideal transfer characteristic of the MP8820 is shown in *Figure 2*. An actual transfer characteristic with associated error terms is shown in *Figure 3*.

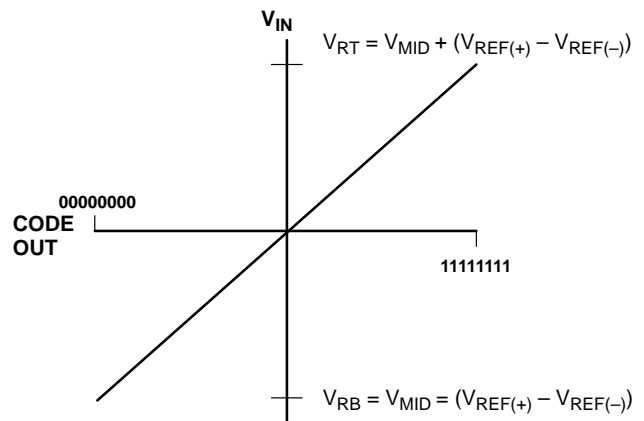

**Figure 2. Ideal Transfer Characteristics**

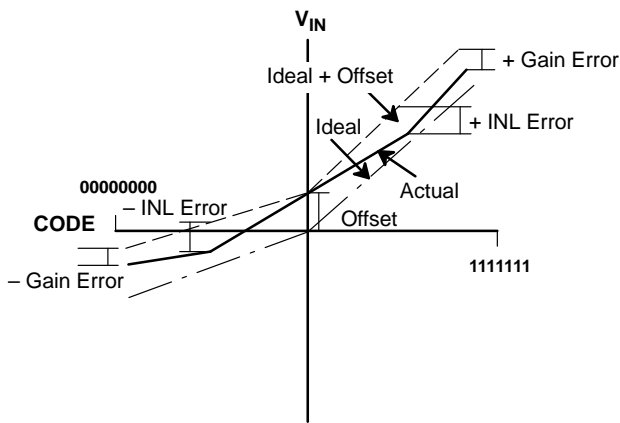

**Figure 3. Transfer Characteristics with Error Terms**

The sign of the digital output code is determined by whether the input voltage,  $A_{IN}$ , exceeds  $V_{MID}$ . If  $A_{IN}$  is greater than  $V_{MID}$ , then the seven bit conversion occurs in the positive half of the transfer function. If  $A_{IN}$  is less than  $V_{MID}$ , then the translation oc-

curs in the negative half of the transfer function. *Table 1.* shows the digital codes that result from different input voltages.

CODE	$A_{IN}$
00000000	-FS
00000001	-FS + 1LSB
.	.
10000000	$V_{MID} = BZ$
.	.
11111110	FS - 2LSB
11111111	FS - 1LSB

**Table 1. Digital Codes vs. Input Voltage**

The MP8820 uses a stand alone  $\mu P$  interface. The user starts a conversion by taking  $\overline{WR}$  low. While  $\overline{WR}$  is low, the input track and hold follows the input voltage,  $A_{IN}$ . On the rising edge of  $\overline{WR}$ , the input is sampled. The rising edge of  $\overline{WR}$  enables a state machine which steps the ADC through a conversion.

The output port is held in high impedance state during the conversion period. The operating timing diagrams are shown in *Figure 4.*

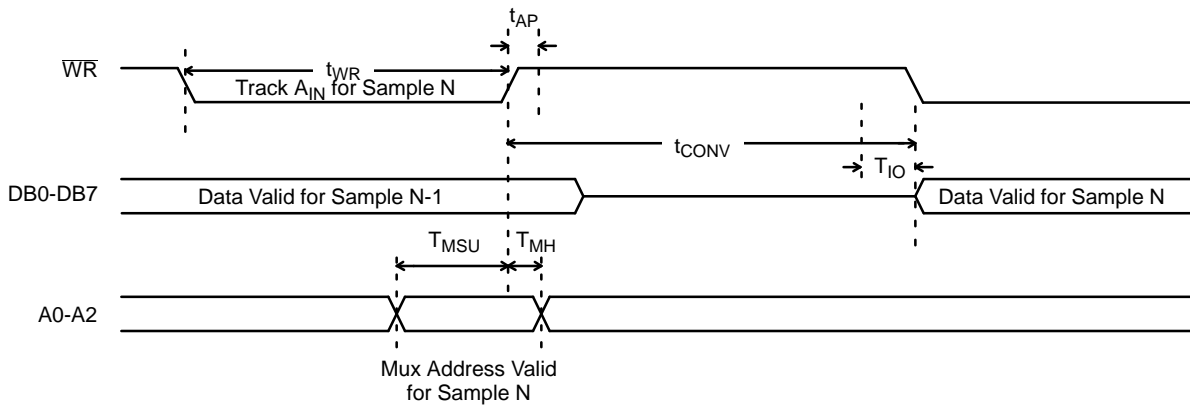
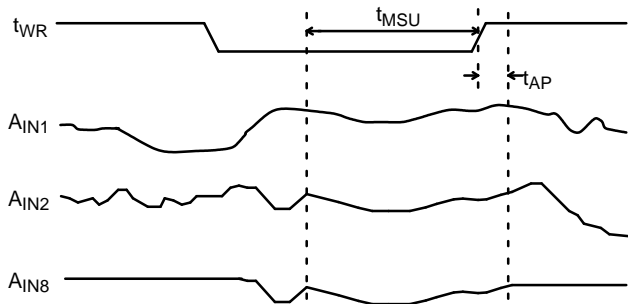

**Figure 4. Operating Timing Diagrams**

## Analog To Digital Conversion

The MP8820 converts analog voltages into 256 digital codes by encoding the outputs of 15 coarse and 15 fine comparators. When  $\overline{WR}$  goes low, the input sample and hold circuitry is enabled. The track and hold circuit will follow the output of the 8 channel mux. The channel that is to be converted does not need to be selected until a time equal to  $T_{MSU}$ , or 150 ns, before the rising edge of  $\overline{WR}$ . So, while  $\overline{WR}$  is low, the track and hold circuit only has to follow the analog input to be converted for 150 ns.

The analog input is sampled at a time equal to the aperture delay,  $T_{AP}$ , after the rising edge of  $\overline{WR}$ . The aperture delay also accounts for internal propagation delays. The mux address lines may also select a new channel at a time equal to  $T_{AP}$  following the rising edge of  $\overline{WR}$ . For the analog timing diagram, see *Figure 5.*



**Figure 5. Analog Timing Diagram**

Inside the ADC is a series of comparators that sample the analog input and compare it against a resistor tap voltage. A state machine generates the internal clocks necessary to control the comparators,  $\phi_C$  (CLK high) and  $\phi_S$  (CLK low = sample). See Figure 6. The rising edge of the CLK input marks the end of the sampling phase,  $\phi_S$ . On  $\phi_S$ , the analog input voltage is sampled and stored across capacitor C1. The switches controlled by  $\phi_S$  are opened prior to the compare which is done on

clock phase  $\phi_C$ . The voltage stored on the capacitor is then equal to  $V_{BAL} + (V_{IN} - V_{TAP})$ . This voltage will force the inverter high or low and the result is latched.

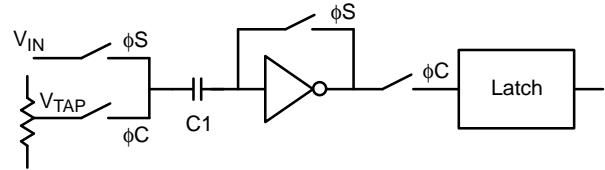

**Figure 6. Comparator Block Diagram**

The analog to digital conversion happens in four phases. During the first phase, the analog input is sampled. During the second phase, this input is compared against the reference ladder to determine the MSBs. After the MSBs are determined, a subrange is set for phase three, the conversion of the LSBs. Once all the bits have been derived, the MP8820 performs a correction. The valid data is then ready at the output. The timing diagram is shown in Figure 7.

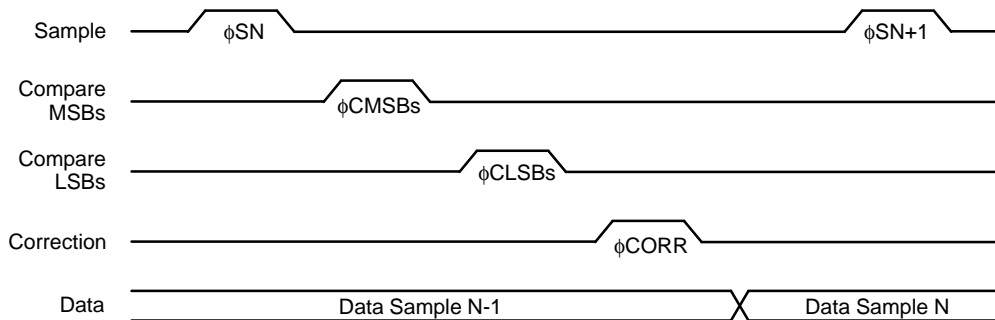

**Figure 7. Internal ADC Timing Diagram**

The input mux operates as a standard 8 to 1 decoder. One of eight analog inputs is selected depending on the condition of the address pins A0, A1, and A2. The mux can change address af-

ter a time equal to  $t_{AP}$  following the rising edge of  $\overline{WR}$ . The address should be held constant for at least 150 ns before the rising edge of  $\overline{WR}$ .

Function	WR	XINT	A0	A1	A2
Start $A_{IN}$ tracking	↓	1	X	X	X
Sample $A_{IN}$	↑	1	X	X	X
Start Convert	↑	1	X	X	X
Conversion Complete	1	↓	X	X	X
Enable Output Data	X	0	X	X	X
Select Input $A_{IN1}$	X	X	0	0	0
Select Input $A_{IN2}$	X	X	0	0	1
Select Input $A_{IN3}$	X	X	0	1	0
Select Input $A_{IN4}$	X	X	0	1	1
Select Input $A_{IN5}$	X	X	1	0	0
Select Input $A_{IN6}$	X	X	1	0	1
Select Input $A_{IN7}$	X	X	1	1	0
Select Input $A_{IN8}$	X	X	1	1	1

**Table 2. Truth Table**

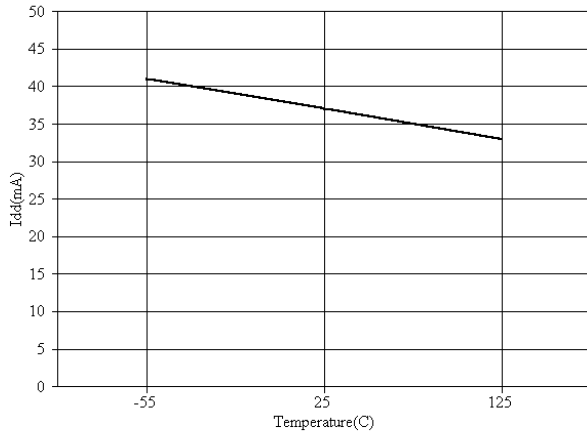

**Graph 1. Supply Current vs. Temperature**

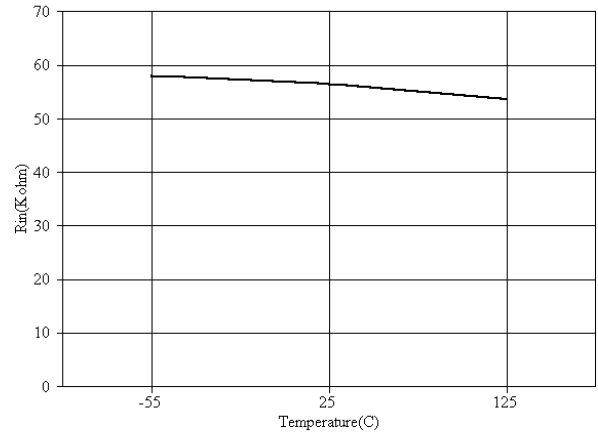

**Graph 2. Input Resistance vs. Temperature**

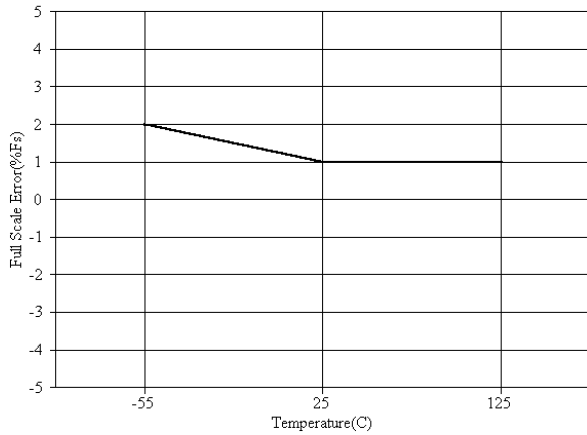

**Graph 3. Full Scale Error vs. Temperature**

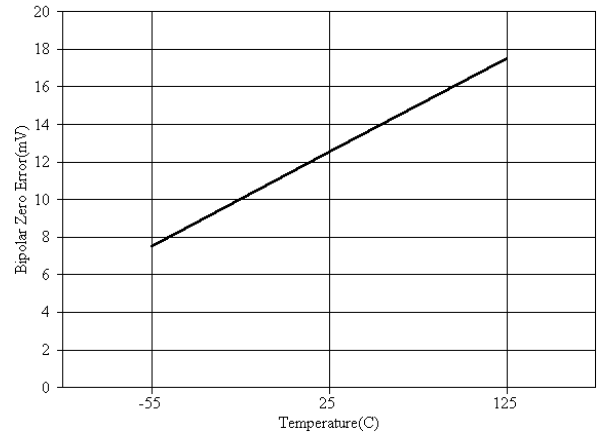

**Graph 4. Bipolar Zero Error vs. Temperature**

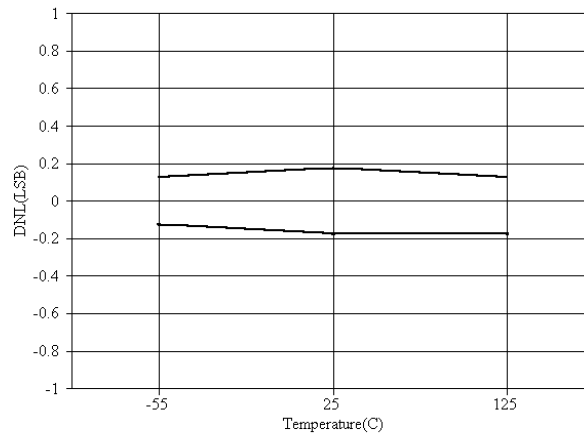

**Graph 5. DNL vs. Temperature**



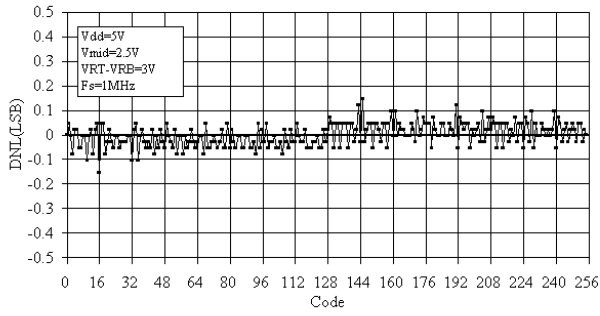

**Graph 6. DNL Error Plot**

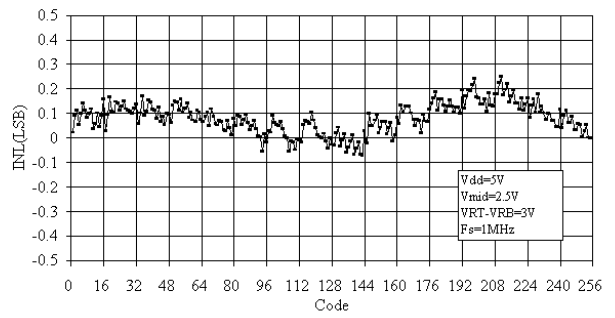

**Graph 7. INL Error Plot for  
7-Bit + Sign ADC**

## 28 LEAD SMALL OUTLINE (300 MIL JEDEC SOIC) S28

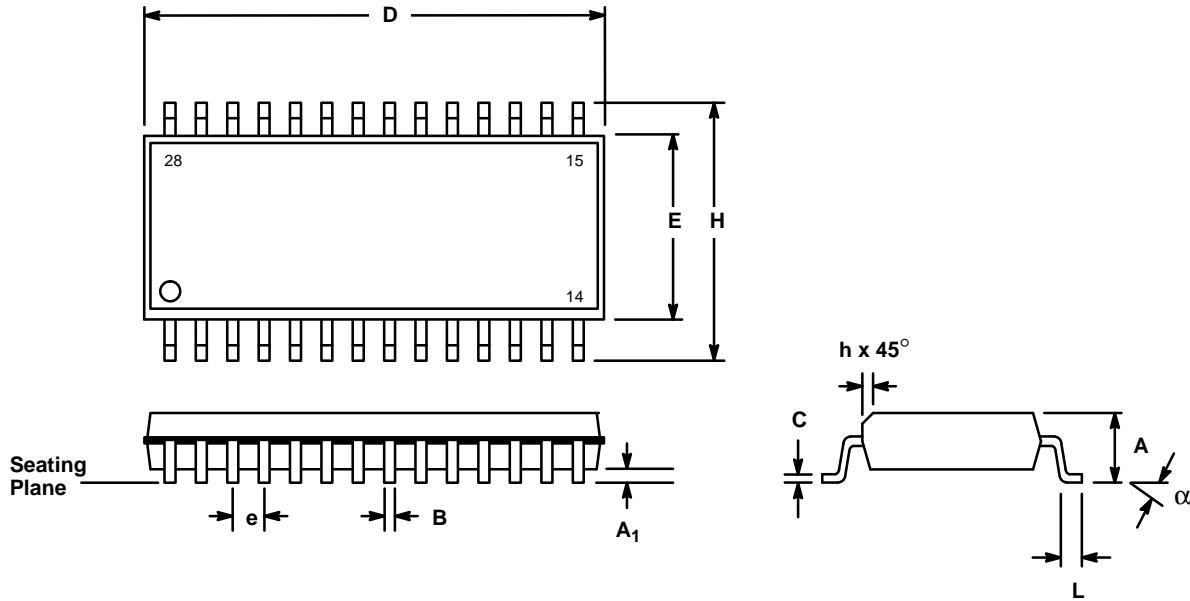

SYMBOL	INCHES		MILLIMETERS	
	MIN	MAX	MIN	MAX
A	0.097	0.104	2.464	2.642
A1	0.0050	0.0115	0.127	0.292
B	0.014	0.019	0.356	0.483
C	0.0091	0.0125	0.231	0.318
D	0.701	0.711	17.81	18.06
E	0.292	0.299	7.42	7.59
e	0.050 BSC		1.27 BSC	
H	0.400	0.410	10.16	10.41
h	0.010	0.016	0.254	0.406
L	0.016	0.035	0.406	0.889
$\alpha$	0°	8°	0°	8°

**28 LEAD SHRINK SMALL OUTLINE PACKAGE  
(SSOP)  
A28**

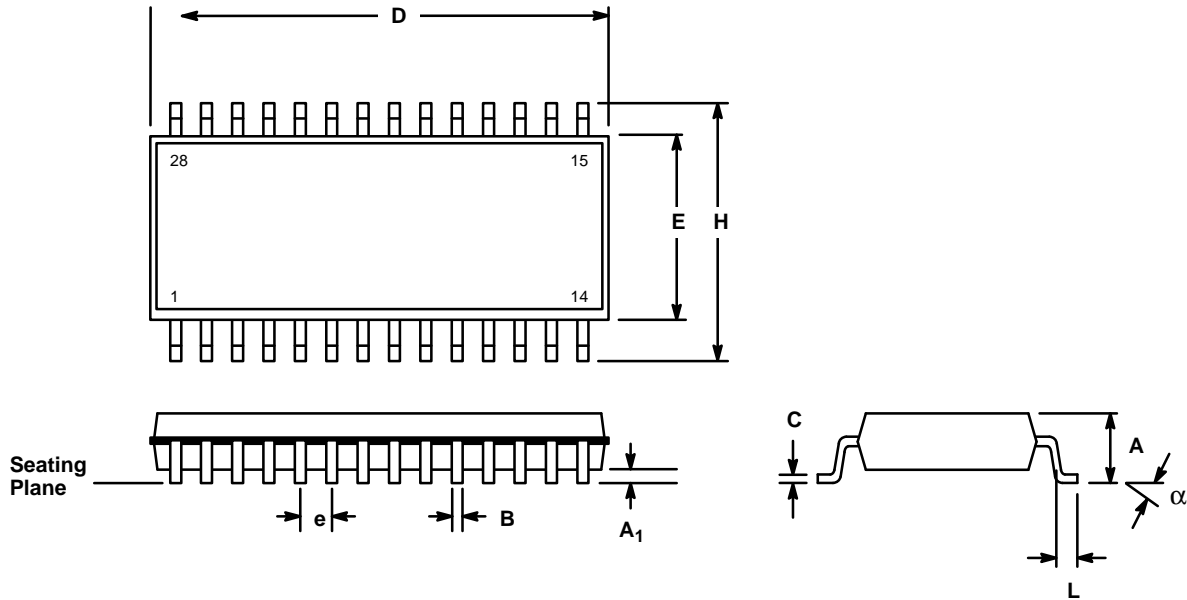

SYMBOL	MILLIMETERS		INCHES	
	MIN	MAX	MIN	MAX
A	1.73	2.05	0.068	0.081
A <sub>1</sub>	0.05	0.21	0.002	0.008
B	0.20	0.40	0.008	0.016
C	0.13	0.25	0.005	0.010
D	10.07	10.40	0.397	0.409
E	5.20	5.38	0.205	0.212
e	0.65 BSC		0.0256 BSC	
H	7.65	8.1	0.301	0.319
L	0.45	0.95	0.018	0.037
$\alpha$	0°	8°	0°	8°

## NOTICE

EXAR Corporation reserves the right to make changes to the products contained in this publication in order to improve design, performance or reliability. EXAR Corporation assumes no responsibility for the use of any circuits described herein, conveys no license under any patent or other right, and makes no representation that the circuits are free of patent infringement. Charts and schedules contains here in are only for illustration purposes and may vary depending upon a user's specific application. While the information in this publication has been carefully checked; no responsibility, however, is assumed for inaccuracies.

EXAR Corporation does not recommend the use of any of its products in life support applications where the failure or malfunction of the product can reasonably be expected to cause failure of the life support system or to significantly affect its safety or effectiveness. Products are not authorized for use in such applications unless EXAR Corporation receives, in writing, assurances to its satisfaction that: (a) the risk of injury or damage has been minimized; (b) the user assumes all such risks; (c) potential liability of EXAR Corporation is adequately protected under the circumstances.

Copyright 1995 EXAR Corporation  
Datasheet April 1995

Reproduction, in part or whole, without the prior written consent of EXAR Corporation is prohibited.