



LOW VOLTAGE 1:18 CLOCK DISTRIBUTION CHIP

MPC940L

The MPC940L is a 1:18 low voltage clock distribution chip with 2.5 V or 3.3 V LVCMOS output capabilities. The device features the capability to select either a differential LVPECL or an LVCMOS compatible input. The 18 outputs are 2.5 V or 3.3 V LVCMOS compatible and feature the drive strength to drive 50 Ω series or parallel terminated transmission lines. With output-to-output skews of 150 ps, the MPC940L is ideal as a clock distribution chip for the most demanding of synchronous systems. The 2.5 V outputs also make the device ideal for supplying clocks for a high performance microprocessor based design. For a similar device at a lower price/performance point, the reader is referred to the MPC9109.

www.DataSheet4U.com

- LVPECL or LVCMOS Clock Input
- 2.5 V LVCMOS Outputs for Pentium II Microprocessor Support
- 150 ps Maximum Output-to-Output Skew
- Maximum Output Frequency of 250 MHz
- 32-Lead LQFP Packaging
- 32-Lead Pb-Free Package Available
- Dual or Single Supply Device:
 - Dual V_{CC} Supply Voltage, 3.3 V Core and 2.5 V Output
 - Single 3.3 V V_{CC} Supply Voltage for 3.3 V Outputs
 - Single 2.5 V V_{CC} Supply Voltage for 2.5 V I/O

With a low output impedance ($\approx 20 \Omega$), in both the HIGH and LOW logic states, the output buffers of the MPC940L are ideal for driving series terminated transmission lines. With a 20 Ω output impedance the 940L has the capability of driving two series terminated lines from each output. This gives the device an effective fanout of 1:36. If a lower output impedance is desired please see the MPC942 data sheet.

The differential LVPECL inputs of the MPC940L allow the device to interface directly with a LVPECL fanout buffer like the MC100EP111 to build very wide clock fanout trees or to couple to a high frequency clock source. The LVCMOS input provides a more standard interface for applications requiring only a single clock distribution chip at relatively low frequencies. In addition, the two clock sources can be used to provide for a test clock interface as well as the primary system clock. A logic HIGH on the LVCMOS_CLK_SEL pin will select the LVCMOS level clock input. All inputs of the MPC940L have internal pullup/pulldown resistors so they can be left open if unused.

The MPC940L is a single or dual supply device. The device power supply offers a high degree of flexibility. The device can operate with a 3.3 V core and 3.3 V output, a 3.3 V core and 2.5 V outputs as well as a 2.5 V core and 2.5 V outputs. The 32-lead LQFP package was chosen to optimize performance, board space and cost of the device. The 32-lead LQFP has a 7x7 mm body size with a conservative 0.8 mm pin spacing.

MPC940L

**LOW VOLTAGE
1:18 CLOCK
DISTRIBUTION CHIP**



**FA SUFFIX
32-LEAD LQFP PACKAGE
CASE 873A-04**



**AC SUFFIX
32-LEAD LQFP PACKAGE
Pb-FREE PACKAGE
CASE 873A-04**

Pentium II is a trademark of Intel Corporation.

MPC940L
LOW VOLTAGE 1:18 CLOCK DISTRIBUTION CHIP



Pinout: 32-Lead LQFP (Top View)

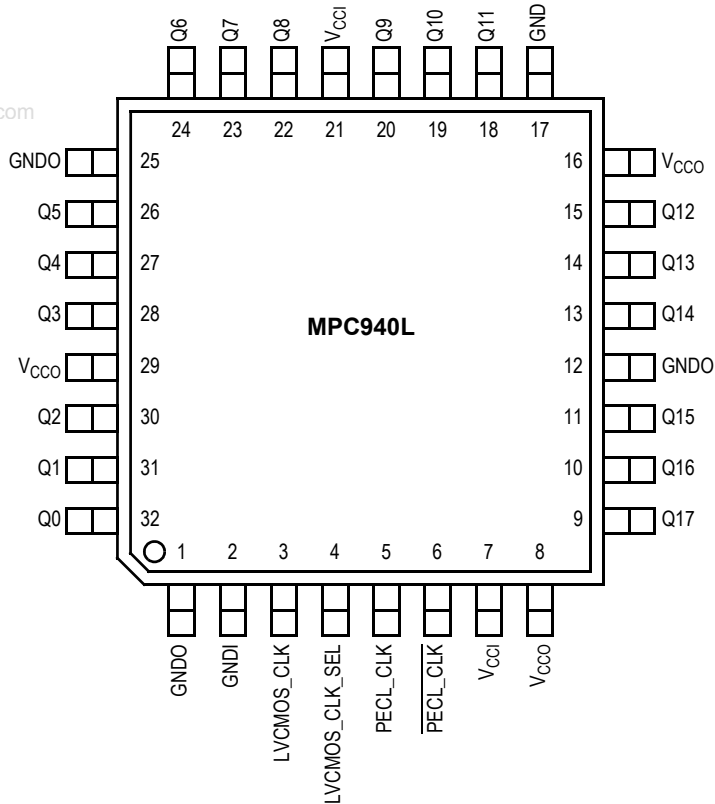

FUNCTION TABLE

LVC MOS_CLK_SEL	Input
0	PECL_CLK
1	LVC MOS_CLK

POWER SUPPLY VOLTAGES

Supply Pin	Voltage Level
V _{CCI}	2.5 V or 3.3 V ± 5%
V _{CCO}	2.5 V or 3.3 V ± 5%

Table 1. Pin Configurations

Pin	I/O	Type	Function
PECL_CLK	Input	LVPECL	Reference Clock Input
PECL_CLK			
LVC MOS_CLK	Input	LVC MOS	Alternative Reference Clock Input
LVC MOS_CLK_SEL	Input	LVC MOS	Selects Clock Source
Q0–Q17	Output	LVC MOS	Clock Outputs
V _{CCO}		Supply	Output Positive Power Supply
V _{CCI}		Supply	Core Positive Power Supply
GND0		Supply	Output Negative Power Supply
GNDI		Supply	Core Negative Power Supply

Table 2. Absolute Maximum Ratings⁽¹⁾

Symbol	Parameter	Min	Max	Unit
V _{CC}	Supply Voltage	-0.3	3.6	V
V _I	Input Voltage	-0.3	V _{DD} + 0.3	V
I _{IN}	Input Current		±20	mA
T _{Stor}	Storage Temperature Range	-40	125	°C

1. Absolute maximum continuous ratings are those values beyond which damage to the device may occur. Exposure to these conditions or conditions beyond those indicated may adversely affect device reliability. Functional operation under absolute-maximum-rated conditions is not implied.

Table 3. DC Characteristics (T_A = 0° to 70°C, V_{CCI} = 3.3 V ±5%; V_{CCO} = 3.3 V ±5%)

Symbol	Characteristic	Min	Typ	Max	Unit	Condition
V _{IH}	Input HIGH Voltage CMOS_CLK	2.4		V _{CCI}	V	
V _{IL}	Input LOW Voltage CMOS_CLK			0.8	V	
V _{PP}	Peak-to-Peak Input Voltage PECL_CLK	500		1000	mV	
V _{CMR}	Common Mode Range PECL_CLK	V _{CCI} - 1.4		V _{CCI} - 0.6	V	
V _{OH}	Output HIGH Voltage	2.4			V	I _{OH} = -20 mA
V _{OL}	Output LOW Voltage			0.5	V	I _{OL} = 20 mA
I _{IN}	Input Current			±200	μA	
C _{IN}	Input Capacitance		4.0		pF	
C _{pd}	Power Dissipation Capacitance		10		pF	per output
Z _{OUT}	Output Impedance	18	23	28	Ω	
I _{CC}	Maximum Quiescent Supply Current		0.5	1.0	mA	

Table 4. AC Characteristics (T_A = 0° to 70°C, V_{CCI} = 3.3 V ±5%; V_{CCO} = 3.3 V ±5%)

Symbol	Characteristic	Min	Typ	Max	Unit	Condition
F _{max}	Maximum Input Frequency			250	MHz	
t _{PLH}	Propagation Delay PECL_CLK ≤ 150 MHz CMOS_CLK ≤ 150 MHz	2.0 1.8	2.7 2.5	3.4 3.0	ns	
t _{PLH}	Propagation Delay PECL_CLK > 150 MHz CMOS_CLK > 150 MHz	2.0 1.8	2.9 2.4	3.7 3.2	ns	
t _{sk(o)}	Output-to-Output Skew PECL_CLK CMOS_CLK			150 150	ps	
t _{sk(pp)}	Part-to-Part Skew PECL_CLK ≤ 150 MHz CMOS_CLK ≤ 150 MHz			1.4 1.2	ns	Note ⁽¹⁾
t _{sk(pp)}	Part-to-Part Skew PECL_CLK > 150 MHz CMOS_CLK > 150 MHz			1.7 1.4	ns	Note ⁽¹⁾
t _{sk(pp)}	Part-to-Part Skew PECL_CLK CMOS_CLK			850 750	ps	Note ⁽²⁾
DC	Output Duty Cycle f _{CLK} < 134 MHz f _{CLK} ≤ 250 MHz	45 40	50 50	55 60	% %	Input DC = 50% Input DC = 50%
t _r , t _f	Output Rise/Fall Time	0.3		1.1	ns	0.5 – 2.4 V

1. Across temperature and voltage ranges. Includes output skew.
2. For specific temperature and voltage. Includes output skew.

Table 5. DC Characteristics ($T_A = 0^\circ$ to 70°C , $V_{CCI} = 3.3\text{ V} \pm 5\%$; $V_{CCO} = 2.5\text{ V} \pm 5\%$)

Symbol	Characteristic	Min	Typ	Max	Unit	Condition
V_{IH}	Input HIGH Voltage CMOS_CLK	2.4		V_{CCI}	V	
V_{IL}	Input LOW Voltage CMOS_CLK			0.8	V	
V_{PP}	Peak-to-Peak Input Voltage PECL_CLK	500		1000	mV	
V_{CMR}	Common Mode Range PECL_CLK	$V_{CCI} - 1.4$		$V_{CCI} - 0.6$	V	
V_{OH}	Output HIGH Voltage	1.8			V	$I_{OH} = -12\text{ mA}$
V_{OL}	Output LOW Voltage			0.5	V	$I_{OL} = 12\text{ mA}$
I_{IN}	Input Current			± 200	μA	
C_{IN}	Input Capacitance		4.0		pF	
C_{pd}	Power Dissipation Capacitance		10		pF	per output
Z_{OUT}	Output Impedance		23		Ω	
I_{CC}	Maximum Quiescent Supply Current		0.5	1.0	mA	

Table 6. AC Characteristics ($T_A = 0^\circ$ to 70°C , $V_{CCI} = 3.3\text{ V} \pm 5\%$; $V_{CCO} = 2.5\text{ V} \pm 5\%$)

Symbol	Characteristic	Min	Typ	Max	Unit	Condition
F_{max}	Maximum Input Frequency			250	MHz	
t_{PLH}	Propagation Delay PECL_CLK $\leq 150\text{ MHz}$ CMOS_CLK $\leq 150\text{ MHz}$	2.0 1.7	2.8 2.5	3.5 3.0	ns	
t_{PLH}	Propagation Delay PECL_CLK $> 150\text{ MHz}$ CMOS_CLK $> 150\text{ MHz}$	2.0 1.8	2.9 2.5	3.8 3.3	ns	
$t_{sk(o)}$	Output-to-Output Skew PECL_CLK CMOS_CLK			150 150	ps	
$t_{sk(pp)}$	Part-to-Part Skew PECL_CLK $\leq 150\text{ MHz}$ CMOS_CLK $\leq 150\text{ MHz}$			1.5 1.3	ns	Note ⁽¹⁾
$t_{sk(pp)}$	Part-to-Part Skew PECL_CLK $> 150\text{ MHz}$ CMOS_CLK $> 150\text{ MHz}$			1.8 1.5	ns	Note ⁽¹⁾
$t_{sk(pp)}$	Part-to-Part Skew PECL_CLK CMOS_CLK			850 750	ps	Note ⁽²⁾
DC	Output Duty Cycle $f_{CLK} < 134\text{ MHz}$ $f_{CLK} \leq 250\text{ MHz}$	45 40	50 50	55 60	% %	Input DC = 50% Input DC = 50%
t_r, t_f	Output Rise/Fall Time	0.3		1.2	ns	0.5 – 1.8 V

1. Across temperature and voltage ranges. Includes output skew.
2. For specific temperature and voltage. Includes output skew.

Table 7. DC Characteristics ($T_A = 0^\circ$ to 70°C , $V_{CCI} = 2.5\text{ V} \pm 5\%$; $V_{CCO} = 2.5\text{ V} \pm 5\%$)

Symbol	Characteristic	Min	Typ	Max	Unit	Condition
V_{IH}	Input HIGH Voltage CMOS_CLK	2.0		V_{CCI}	V	
V_{IL}	Input LOW Voltage CMOS_CLK			0.8	V	
V_{PP}	Peak-to-Peak Input Voltage PECL_CLK	500		1000	mV	
V_{CMR}	Common Mode Range PECL_CLK	$V_{CCI} - 1.0$		$V_{CCI} - 0.6$	V	
V_{OH}	Output HIGH Voltage	1.8			V	$I_{OH} = -12\text{ mA}$
V_{OL}	Output LOW Voltage			0.5	V	$I_{OL} = 12\text{ mA}$
I_{IN}	Input Current			± 200	μA	
C_{IN}	Input Capacitance		4.0		pF	
C_{pd}	Power Dissipation Capacitance		10		pF	per output
Z_{OUT}	Output Impedance	18	23	28	Ω	
I_{CC}	Maximum Quiescent Supply Current		0.5	1.0	mA	

Table 8. AC Characteristics ($T_A = 0^\circ$ to 70°C , $V_{CCI} = 2.5\text{ V} \pm 5\%$; $V_{CCO} = 2.5\text{ V} \pm 5\%$)

Symbol	Characteristic	Min	Typ	Max	Unit	Condition
F_{max}	Maximum Input Frequency			200	MHz	
t_{PLH}	Propagation Delay PECL_CLK $\leq 150\text{ MHz}$ CMOS_CLK $\leq 150\text{ MHz}$	2.6 2.3	4.0 3.1	5.2 4.0	ns	
t_{PLH}	Propagation Delay PECL_CLK $> 150\text{ MHz}$ CMOS_CLK $> 150\text{ MHz}$	2.8 2.3	3.8 3.1	5.0 4.0	ns	
$t_{sk(o)}$	Output-to-Output Skew PECL_CLK CMOS_CLK			200 200	ps	
$t_{sk(pp)}$	Part-to-Part Skew PECL_CLK $\leq 150\text{ MHz}$ CMOS_CLK $\leq 150\text{ MHz}$			2.6 1.7	ns	Note (1)
$t_{sk(pp)}$	Part-to-Part Skew PECL_CLK $> 150\text{ MHz}$ CMOS_CLK $> 150\text{ MHz}$			2.2 1.7	ns	Note (1)
$t_{sk(pp)}$	Part-to-Part Skew PECL_CLK CMOS_CLK			1.2 1.0	ns	Note (2)
DC	Output Duty Cycle $f_{CLK} < 134\text{ MHz}$ $f_{CLK} \leq 200\text{ MHz}$	45 40	50 50	55 60	% %	Input DC = 50% Input DC = 50%
t_r, t_f	Output Rise/Fall Time	0.3		1.2	ns	0.5 - 1.8 V

1. Across temperature and voltage ranges. Includes output skew.
2. For specific temperature and voltage. Includes output skew.

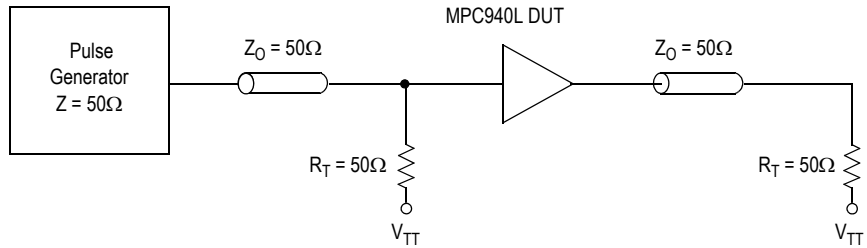

Figure 1. LVC MOS_CLK MPC940L AC Test Reference for $V_{CC} = 3.3\text{ V}$ and $V_{CC} = 2.5\text{ V}$

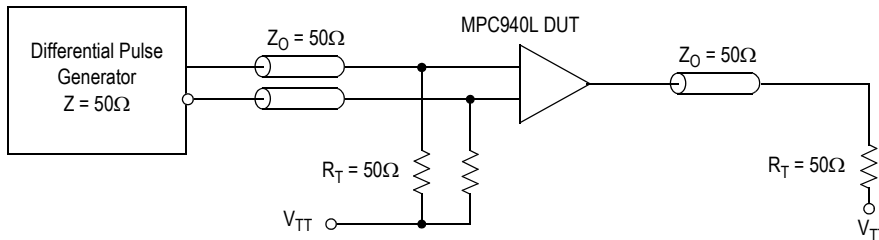

Figure 2. PECL_CLK MPC940L AC Test Reference for $V_{CC} = 3.3\text{ V}$ and $V_{CC} = 2.5\text{ V}$

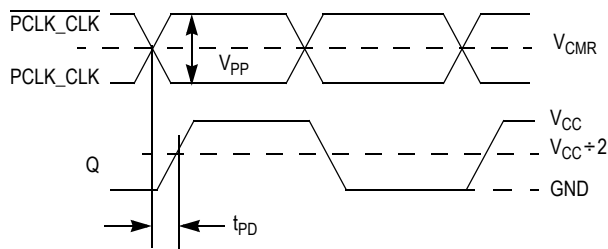

Figure 3. Propagation Delay (t_{pD}) Test Reference

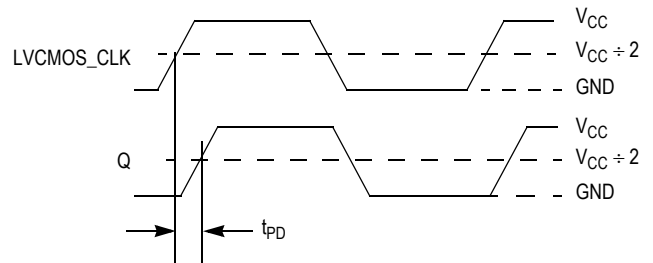
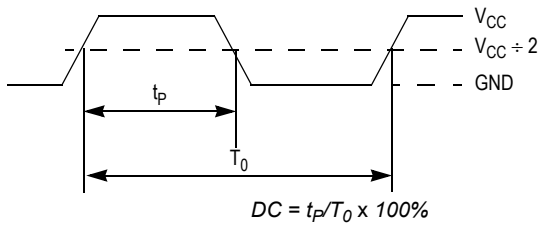
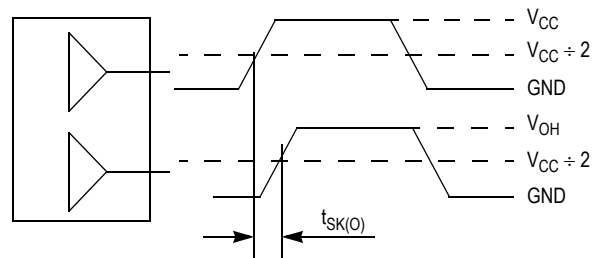

Figure 4. LVC MOS Propagation Delay (t_{pD}) Test Reference



The time from the PLL controlled edge to the non controlled edge, divided by the time between PLL controlled edges, expressed as a percentage.

Figure 5. Output Duty Cycle (DC)



The pin-to-pin skew is defined as the worst case difference in propagation delay between any two similar delay paths within a single device.

Figure 6. Output-to-Output Skew $T_{sk(0)}$

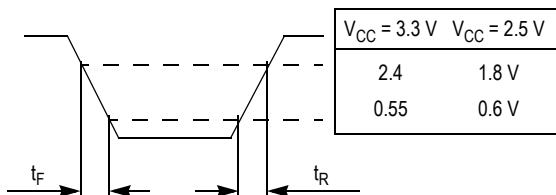

Figure 7. Output Transition Time Test Reference

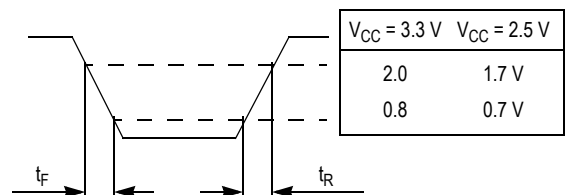
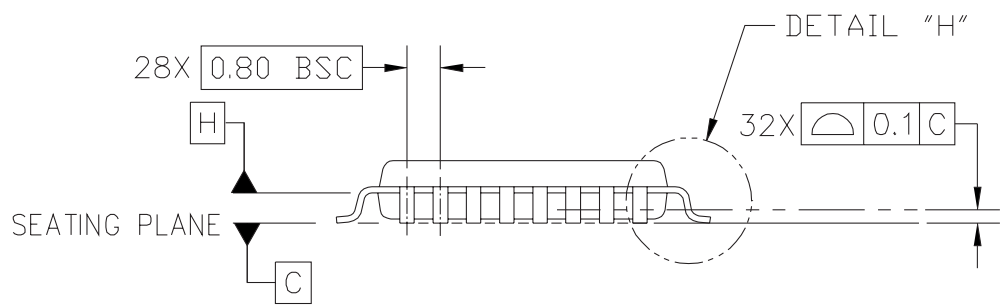
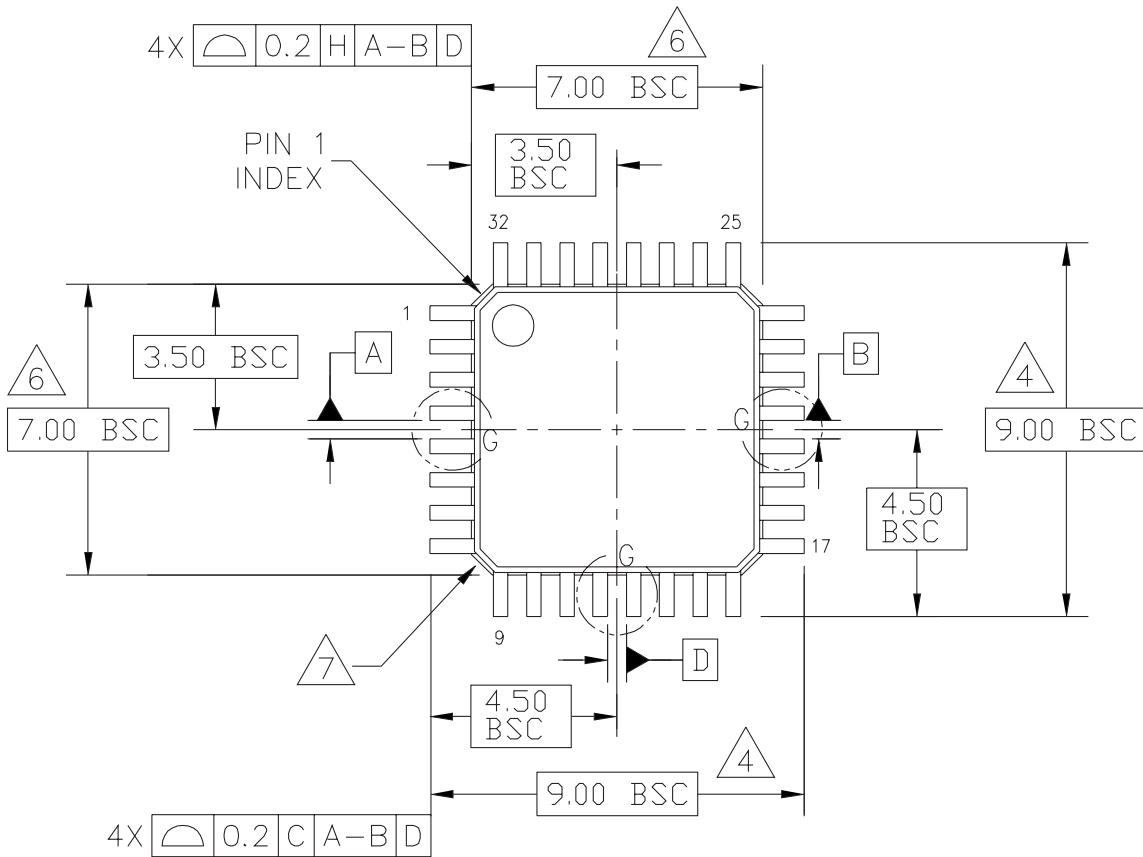

Figure 8. Input Transition Time Test Reference

PACKAGE DIMENSIONS



© FREESCALE SEMICONDUCTOR, INC. ALL RIGHTS RESERVED.	MECHANICAL OUTLINE	PRINT VERSION NOT TO SCALE	
TITLE: LOW PROFILE QUAD FLAT PACK (LQFP) 32 LEAD, 0.8 PITCH (7 X 7 X 1.4)	DOCUMENT NO: 98ASH70029A	REV: C	
	CASE NUMBER: 873A-04	01 APR 2005	
	STANDARD: JEDEC MS-026 BBA		

CASE 873A-04
ISSUE C
32-LEAD LQFP PACKAGE

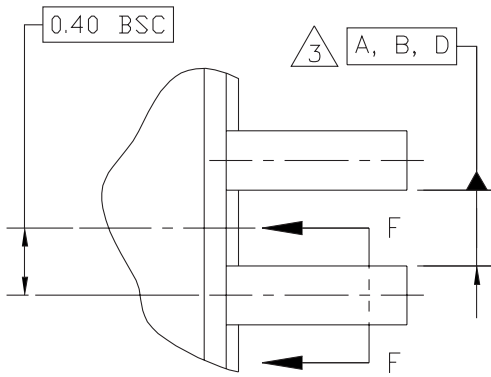

DETAIL G

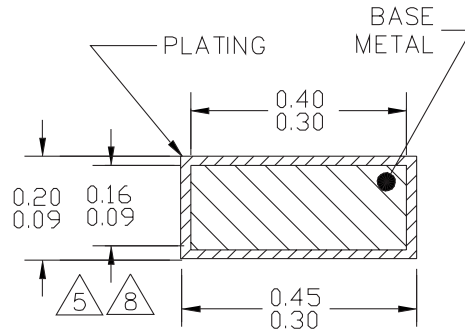

⊕ 0.2 M C A-B D

SECTION F-F
 ROTATED 90°CW
 32 PLACES

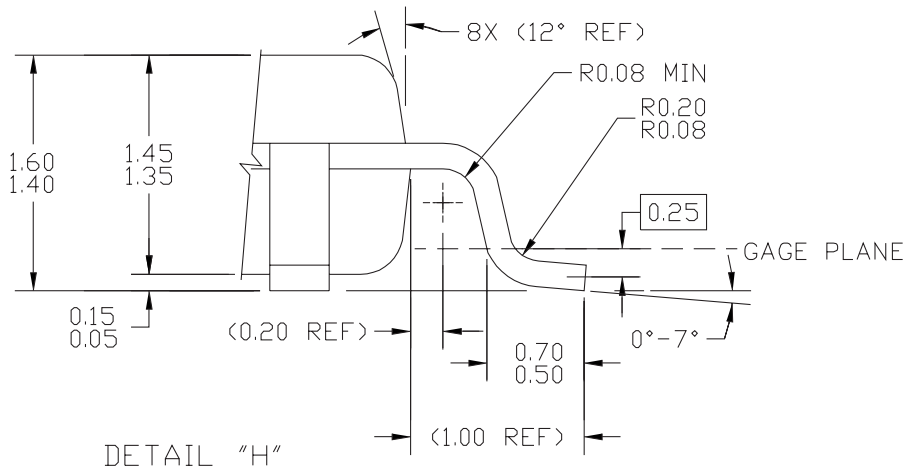

DETAIL "H"

© FREESCALE SEMICONDUCTOR, INC. ALL RIGHTS RESERVED.	MECHANICAL OUTLINE	PRINT VERSION NOT TO SCALE	
TITLE: LOW PROFILE QUAD FLAT PACK (LQFP) 32 LEAD, 0.8 PITCH (7 X 7 X 1.4)	DOCUMENT NO: 98ASH70029A	REV: C	
	CASE NUMBER: 873A-04	01 APR 2005	
	STANDARD: JEDEC MS-026 BBA		

PAGE 2 OF 3

CASE 873A-04
ISSUE C
32-LEAD LQFP PACKAGE

PACKAGE DIMENSIONS

NOTES:

1. DIMENSIONS ARE IN MILLIMETERS.
2. INTERPRET DIMENSIONS AND TOLERANCES PER ASME Y14.5-1994.
3. DATUMS A, B, AND D TO BE DETERMINED AT DATUM PLANE H.
4. DIMENSIONS TO BE DETERMINED AT SEATING PLANE DATUM C.
5. DIMENSION DOES NOT INCLUDE DAMBAR PROTRUSION. ALLOWABLE DAMBAR PROTRUSION SHALL NOT CAUSE THE LEAD WIDTH TO EXCEED THE MAXIMUM DIMENSION BY MORE THAN 0.08 MM. DAMBAR CANNOT BE LOCATED ON THE LOWER RADIUS OR THE FOOT. MINIMUM SPACE BETWEEN PROTRUSION AND ADJACENT LEAD OR PROTRUSION: 0.07 MM.
6. DIMENSIONS DO NOT INCLUDE MOLD PROTRUSION. ALLOWABLE PROTRUSION IS 0.25 MM PER SIDE. DIMENSIONS ARE MAXIMUM PLASTIC BODY SIZE DIMENSIONS INCLUDING MOLD MISMATCH.
7. EXACT SHAPE OF EACH CORNER IS OPTIONAL.
8. THESE DIMENSIONS APPLY TO THE FLAT SECTION OF THE LEAD BETWEEN 0.1 MM AND 0.25 MM FROM THE LEAD TIP.

www.DataSheet4U.com

© FREESCALE SEMICONDUCTOR, INC. ALL RIGHTS RESERVED.		MECHANICAL OUTLINE	PRINT VERSION NOT TO SCALE
TITLE: LOW PROFILE QUAD FLAT PACK (LQFP) 32 LEAD, 0.8 PITCH (7 X 7 X 1.4)		DOCUMENT NO: 98ASH70029A	REV: C
		CASE NUMBER: 873A-04	01 APR 2005
		STANDARD: JEDEC MS-026 BBA	

PAGE 3 OF 3

CASE 873A-04
ISSUE C
32-LEAD LQFP PACKAGE

Ordering Information

Table 9. Ordering Information

Part/Order Number	Marking	Package	Shipping Packaging	Temperature
MPC940LFA	MPC940L	32 Lead LQFP	Tray	0°C to 70°C
MPC940LFAR2	MPC940L	32 Lead LQFP	2500 Tape & Reel	0°C to 70°C
MPC940LAC	MPC940LAC	Lead-Free, 32 Lead LQFP	Tray	0°C to 70°C
MPC940LACR2	MPC940LAC	Lead-Free, 32 Lead LQFP	2500 Tape & Reel	0°C to 70°C

Innovate with IDT and accelerate your future networks. Contact:

www.IDT.com

For Sales

800-345-7015
408-284-8200
Fax: 408-284-2775

For Tech Support

netcom@idt.com
480-763-2056

Corporate Headquarters

Integrated Device Technology, Inc.
6024 Silver Creek Valley Road
San Jose, CA 95138
United States
800 345 7015
+408 284 8200 (outside U.S.)

Asia Pacific and Japan

Integrated Device Technology
Singapore (1997) Pte. Ltd.
Reg. No. 199707558G
435 Orchard Road
#20-03 Wisma Atria
Singapore 238877
+65 6 887 5505

Europe

IDT Europe, Limited
321 Kingston Road
Leatherhead, Surrey
KT22 7TU
England
+44 (0) 1372 363 339
Fax: +44 (0) 1372 378851

