



MPQ2286

6V, 12A, Programmable High Frequency Synchronous Buck Regulator, AEC1-Q100 Qualified

DESCRIPTION

The MPQ2286 is a configurable, high-frequency, synchronous buck regulator with integrated internal high-side and low-side power MOSFETs (HS-FET and LS-FET, respectively). The MPQ2286 operates from a 2.7V to 6V input voltage (V_{IN}) and provides 12A of highly efficient output current (I_{OUT}) with fixed-frequency, zero-delay PWM (ZDP™) control for optimal transient response.

The configurable 2MHz to 4MHz switching frequency (f_{sw}) during forced continuous conduction mode (FCCM) greatly reduces the external inductance and capacitance. Internal feedback and compensation minimizes the external component count and improves accuracy.

High power conversion efficiency across the wide load range is achieved by scaling down f_{sw} under light-load conditions to reduce the switching frequency and gate driving losses. Full protection features include short-circuit protection (SCP), over-current protection (OCP), input over-voltage protection (OVP), output OVP, and thermal shutdown. These protections provide reliable, fault-tolerant operation.

The digital interface features packeting error checking (PEC), and integrated multi-page one-time programmable (OTP) memory allows for a high degree of configurability.

The MPQ2286 is available in a QFN-18 (3mmx4mm) package with wettable flanks. It is available in AEC-Q100 Grade 1.

FEATURES

- Designed for Automotive Point-of-Load (PoL) Applications
 - 2.7V to 6V Input Voltage (V_{IN})
 - 12A Continuous Output Current (I_{OUT})
 - 1.0% Output Regulation Accuracy
 - Differential Output Voltage (V_{OUT}) Sense
 - Internal 6mΩ High-Side MOSFET (HS-FET) and 4mΩ Low-Side MOSFET (LS-FET)

FEATURES (continued)

- Configurable 2MHz to 4MHz Switching Frequency (f_{sw})
- Optimized for EMC/EMI
 - Synchronization Input/Output
 - Frequency Spread Spectrum (FSS)
- Flexible Application with Digital Interface
 - Digital Interface with Cyclic Redundancy Check (CRC)
 - Converter On/Off
 - V_{OUT} Setting Range from 0.20625V to 3.6V
 - Faults Detection
 - Factory-Configurable Multi-Page One-Time Programmable (OTP) Memory
- Protections
 - Peak and Valley Current Limit
 - Over-Current Protection (OCP)
 - Short Circuit Protection (SCP)
 - Output Over Voltage Protection (OVP)
 - Input OVP
 - Thermal Warning
 - Over-Temperature Shutdown
- Additional Features
 - Soft Start and Soft Stop
 - Power Good
 - Available in a QFN-18 (3mmx4mm) Package with Wettable Flanks
 - Available in AEC-Q100 Grade 1
- Functional Safety System Design Capable
 - MPSafe™ QM - Documentation Available



APPLICATIONS

- Advanced Driver Assistance Systems (ADAS)
- Infotainment
- System-On-Chip (SOC) System Cores
- DDR Memory

All MPS parts are lead-free, halogen-free, and adhere to the RoHS directive. For MPS green status, please visit the MPS website under Quality Assurance. "MPS", the MPS logo, and "Simple, Easy Solutions" are trademarks of Monolithic Power Systems, Inc. or its subsidiaries.

ORDERING INFORMATION

Part Number*	Package	Top Marking	MSL Rating***
MPQ2286GLE-xxxx-AEC1 **, ****	QFN-18 (3mmx4mm)	See Below	1

* For Tape & Reel, add suffix -Z (e.g. MPQ2286GLE-xxxx-AEC1-Z).

** "xxxx" is the configuration code identifier for the register settings stored in the OTP register. The first value must be a numerical value (0–9), while the last three values can be a hexadecimal value between 0 and F. The default code is "0000". Contact an MPS FAE to create this unique number.

***Moisture Sensitivity Level Rating

**** Wettable flank

TOP MARKING

MPYW

2286

LLL

E

MP: MPS prefix
 Y: Year code
 W: Week code
 2286: Part number
 LLL: Lot number
 E: Wettable Flank

PACKAGE REFERENCE

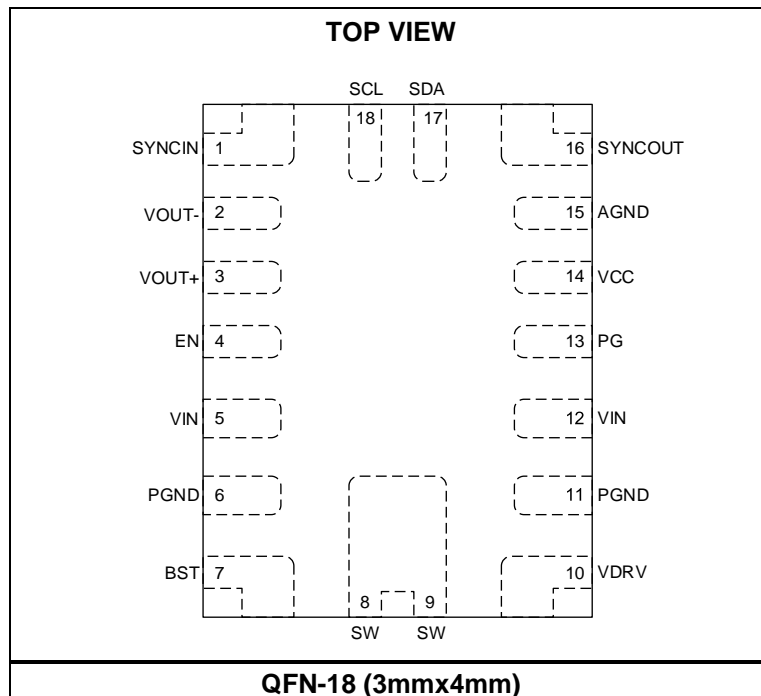

PIN FUNCTIONS

Pin #	Name	Description
1	SYNCIN	SYNC input. Apply a clock signal to the SYNCN pin to synchronize the internal oscillator frequency to the external clock. Use an external clock to enter forced continuous conduction mode (FCCM). The MPQ2286 can also be set to FCCM via the digital interface. Connect SYNCIN to GND through a resistor if it is not used.
2	VOUT-	Output negative differential sense. Connect VOUT- to the negative side of the output capacitor.
3	VOUT+	Output positive differential sense. Connect VOUT+ to the positive side of the output capacitor.
4	EN	Enable. Pull the EN pin below the specified threshold (1.1V) to shut down the chip. Pull EN above the specified threshold (1.2V) to enable the chip. There is an internal 200kΩ pull-down resistor.
5, 12	VIN	Input supply. The VIN pins are connected internally. VIN supplies power to the internal low-dropout (LDO) regulator, control circuitry, and the power switch connected to SW. It is recommended to connect a decoupling capacitor from VIN to ground, and placed close to VIN to minimize switching spikes.
6, 11	PGND	Power ground. The PGND pins are connected internally.
7	BST	Bootstrap supply. The BST pin is the positive power supply for the high-side MOSFET driver connected to SW. Connect a 0.22μF bypass capacitor between the BST and SW pins.
8,9	SW	Switch node. SW is the output of the internal power switch. Connect SW to the power inductor.
10	VDRV	Internal LDO decoupling pin and supply input for internal power circuits. Connect a 4.7μF capacitor from VDRV to PGND. Connect a 2.2Ω resistor between VCC and VDRV.
13	PG	Power good indicator. The PG pin is an open-drain output. PG asserts if the output is not within regulation, or if an error has occurred. This pin can be configured via the digital interface. Connect PG to GND through a resistor if it is not used.
14	VCC	Supply input for internal analog and digital circuits. Connect a 2.2μF capacitor from VCC to AGND. Connect a 2.2Ω resistor between VCC and VDRV.
15	AGND	Analog ground.
16	SYNCOUT	SYNC output. SYNCOUT outputs a 0° or 180° out-of-phase clock to the other devices.
17	SDA	Digital interface serial data. This pin is an open-drain port and cannot be floated. Use an external pull-up resistor to connect this pin to the supply rail of the digital interface. Connect this pin to GND if it is not used.
18	SCL	Digital interface serial clock. This pin is an open-drain port and cannot be floated. Use an external pull-up resistor to connect this pin to the supply rail of the digital interface. Connect this pin to GND if it is not used.

ABSOLUTE MAXIMUM RATINGS ⁽¹⁾

V_{IN}, V_{SW}	-0.3V to +8.5V
V_{BST}	-0.3V to 4V + V_{SW}
All other pins	-0.3V to +4V
Continuous power dissipation ($T_A = 25^\circ\text{C}$) ⁽²⁾⁽⁶⁾	
QFN-18 (3mmx4mm)	4.59W
Junction temperature (T_J)	150°C
Lead temperature	260°C

ESD Ratings

Human body model (HBM)	Class 2 ⁽³⁾
Charged-device model (CDM)	Class C2b ⁽⁴⁾

Recommended Operating Conditions

Input voltage (V_{IN})	2.7V to 6V
Output voltage (V_{OUT})	0.20625V to 3.6V
Operating junction temp (T_J)	-40°C to +150°C

Thermal Resistance	θ_{JA}	θ_{JC}
QFN-18 (3mmx4mm)		
JESD51-7	44.67	4.2
EVQ2286-L-00A	27.22	2.86

Notes:

- 1) Exceeding these ratings may damage the device.
- 2) The maximum allowable power dissipation is a function of the maximum junction temperature, T_J (MAX), the junction-to-ambient thermal resistance, θ_{JA} , and the ambient temperature, T_A . The maximum allowable continuous power dissipation at any ambient temperature is calculated by P_D (MAX) = $(T_J$ (MAX) - T_A) / θ_{JA} . Exceeding the maximum allowable power dissipation can cause excessive die temperature, and the regulator may go into thermal shutdown. Internal thermal shutdown circuitry protects the device from permanent damage.
- 3) Per AEC-Q100-002.
- 4) Per AEC-Q100-011.
- 5) Measured on a JESD51-7, 4-layer PCB. The values given in this table are only valid for comparison with other packages and cannot be used for design purposes. These values were calculated in accordance with JESD51-7, and simulated on a specified JEDEC board. They do not represent the performance obtained in an actual application. The value of θ_{JC} shows the thermal resistance from junction-to-case bottom.
- 6) Measured on an MPS standard EVB, 6.35cmx6.35cm, 2oz copper thickness, 4-layer PCB. The value of θ_{JC} shows the thermal resistance from junction-to-case top.

ELECTRICAL CHARACTERISTICS

Typical values are $V_{IN} = 5V$, $V_{EN} = 2V$, $T_J = 25^\circ C$, all voltages with respect to ground, unless otherwise noted. Minimum and maximum values are at $V_{IN} = 5V$, $V_{EN} = 2V$, $T_J = -40^\circ C$ to $+150^\circ C$, all voltages with respect to ground, guaranteed by characterization, unless otherwise noted.

Parameter	Symbol	Condition	Min	Typ	Max	Units
Input Supply Voltage						
Input voltage (V_{IN}) under-voltage lockout (UVLO) rising threshold	V_{IN_UVLO}		2.4		2.7	V
V_{IN} UVLO hysteresis	$V_{IN_UVLO_HYS}$			150		mV
V_{IN} quiescent current	I_{Q_ON}	Buck on, no switching			7	mA
V_{IN} shutdown current	I_{Q_OFF}	Buck off, enable low			20	μA
VDRV Regulator						
VDRV regulation voltage	V_{VDRV}	$C = 2.2\mu F$, $I_{VCC} = 20mA$, $V_{IN} = 5V$	3.1	3.3	3.5	V
VDRV current limit	I_{VDRV}	$V_{VDRV} = 2.7V$, $V_{IN} = 5V$		100		mA
		$V_{VDRV} = 0V$, $V_{IN} = 5V$		100		mA
Oscillator						
Switching frequency range ⁽⁹⁾	f_{SW}		2		4	MHz
Switching frequency accuracy	f_{SW_ACC}		-10		+10	%
Minimum on time	t_{ON_MIN}	$V_{IN} = 5V$, $V_{OUTP} = 2 \times V_{OUT_SCALE}$		26	45	ns
Minimum off time	t_{OFF_MIN}			80		ns
Minimum frequency	f_{SW_MIN}	Ultrasonic mode enabled	40		50	kHz
Spread spectrum modulation frequency spread	f_{SS_SPREAD}			-7.5		%
				+6.5		%
Spread spectrum modulation frequency rate	f_{SS_RATE}			9		kHz
Dynamic Output Voltage (V_{OUT})						
V_{OUT} output range ⁽⁹⁾⁽¹⁰⁾	V_{OUT}		0.206 25		3.6	V
V_{OUT} accuracy	V_{OUT_ACC}	$V_{OUT} \geq 0.5V \times V_{OUT_SCALE}$, as a percentage of V_{OUT}	-1		+1	%
		$V_{OUT_SCALE} = 1$, $V_{OUT} < 0.5V$	-5		+5	mV
		$V_{OUT_SCALE} = 2$, $V_{OUT} < 1V$	-10		+10	mV
V_{OUT} start-up slew rate range ⁽⁹⁾	$V_{OUTSLEW_ST}$		1.25		10	mV/ μs
V_{OUT} start-up slew rate accuracy	$V_{OUTSLEW_ST_ACC}$		-15		+15	%

ELECTRICAL CHARACTERISTICS (continued)

Typical values are $V_{IN} = 5V$, $V_{EN} = 2V$, $T_J = 25^\circ C$, all voltages with respect to ground, unless otherwise noted. Minimum and maximum values are at $V_{IN} = 5V$, $V_{EN} = 2V$, $T_J = -40^\circ C$ to $+150^\circ C$, all voltages with respect to ground, guaranteed by characterization, unless otherwise noted.

Parameter	Symbol	Condition	Min	Typ	Max	Units
V_{OUT} shutdown slew rate range ⁽⁹⁾	$V_{OUTSLEW_SP}$		1.25		10	mV/ μ s
V_{OUT} shutdown slew rate accuracy	$V_{OUTSLEW_SP_ACC}$		-15		+15	%
V_{OUT} dynamic slew rate range ⁽⁹⁾	$V_{OUTSLEW}$		2.5		20	mV/ μ s
V_{OUT} dynamic slew rate accuracy	$V_{OUTSLEW_ACC}$		-15		+15	%
Power Stage						
High-side (HS) switch on resistance	R_{DS_HS}			6	12	m Ω
Low-side (LS) switch on resistance	R_{DS_LS}			4	8	m Ω
HS switch leakage current	I_{LEAK_HS}	$V_{DS} = 6V$			200	μ A
LS switch leakage current	I_{LEAK_LS}	$V_{DS} = 6V$			200	μ A
Peak current limit ⁽⁹⁾	$I_{LIM_HS_BUCK}$	$ILIM_SCALE = 100\%$	18	21	27	A
Valley current limit ⁽⁹⁾	$I_{LIM_LS_BUCK}$	$ILIM_SCALE = 100\%$	12	15	18	A
Zero-current detection (ZCD) current	I_{ZCD_BUCK}				500	mA
Reverse current limit	I_{REV_BUCK}			10		A
Feedback leakage	R_{FB1_BUCK}	$V_{OUT_SCALE} = 1$	20			k Ω
	R_{FB2_BUCK}	$V_{OUT_SCALE} = 2$	20			k Ω
Output discharge	R_{DIS_BUCK}			120		Ω
Bootstrap Supply						
Bootstrap UVLO rising threshold	V_{BST_UVLO}				2.5	V
Bootstrap UVLO Hysteresis	$V_{BST_UVLO_HYS}$		0.2			V
Thermal Protection						
Thermal warning rising threshold ⁽⁷⁾	T_{TW}		125	140	155	$^\circ C$
Thermal warning hysteresis	T_{TW_HYS}			20		$^\circ C$
Thermal shutdown rising threshold ⁽⁷⁾	T_{TSD}		155	170	185	$^\circ C$
Thermal shutdown hysteresis	T_{TSD_HYS}			20		$^\circ C$

ELECTRICAL CHARACTERISTICS (continued)

Typical values are $V_{IN} = 5V$, $V_{EN} = 2V$, $T_J = 25^{\circ}C$, all voltages with respect to ground, unless otherwise noted. Minimum and maximum values are at $V_{IN} = 5V$, $V_{EN} = 2V$, $T_J = -40^{\circ}C$ to $+150^{\circ}C$, all voltages with respect to ground, guaranteed by characterization, unless otherwise noted.

Parameter	Symbol	Condition	Min	Typ	Max	Units
Output Voltage Protection						
V_{OUT} over-voltage (OV) rising threshold	V_{OUT_OV}		113	116	119	%
V_{OUT} OV hysteresis	$V_{OUT_OV_HYS}$			7		%
V_{OUT} under-voltage (UV) falling threshold	V_{OUT_UV}		70	75	80	%
V_{OUT} UV hysteresis	$V_{OUT_UV_HYS}$			7		%
Hiccup time range ⁽⁹⁾	t_{HICK}		2		8	ms
Input Over-Voltage Protection						
V_{IN} OV rising threshold	V_{IN_OV}		6.5	6.7	6.85	V
V_{IN} OV hysteresis	$V_{IN_OV_HYS}$			0.7		V
V_{IN} OV delay time	t_{VIN_OV}			7		μs
Enable						
EN logic on rising threshold	V_{EN_LOG}		0.25	0.65	1	V
EN rising threshold	V_{EN}		1.1	1.2	1.3	V
EN voltage hysteresis	V_{EN_HYS}			100		mV
EN leakage	I_{EN}	$V_{EN} = 3.3V$			10	μA
Power Good (PG)						
PG OV rising threshold ⁽⁹⁾	PG_{OV_TH}	$PG_OV_TH = 0$	103	104	105	%
		$PG_OV_TH = 1$	105	106	107	%
PG OV threshold hysteresis	PG_{OV_HYS}			0.8		%
PG UV falling threshold ⁽⁹⁾	PG_{UV_TH}	$PG_UV_TH = 0$	95	96	97	%
		$PG_UV_TH = 1$	93	94	95	%
PG UV threshold hysteresis	PG_{UV_HYS}			0.8		%
PG sink capability	I_{PG}	$I_{PG} = 1mA$			300	mV
PG delay range ⁽⁹⁾	t_{PG_DELAY}		0		10	ms
PG rising deglitch	$t_{PG_R_DEGLITCH}$			20		μs
PG falling deglitch	$t_{PG_F_DEGLITCH}$			20		μs

ELECTRICAL CHARACTERISTICS (continued)

Typical values are $V_{IN} = 5V$, $V_{EN} = 2V$, $T_J = 25^\circ C$, all voltages with respect to ground, unless otherwise noted. Minimum and maximum values are at $V_{IN} = 5V$, $V_{EN} = 2V$, $T_J = -40^\circ C$ to $+150^\circ C$, all voltages with respect to ground, guaranteed by characterization, unless otherwise noted.

Parameter	Symbol	Condition	Min	Typ	Max	Units
SCL/SDA input logic low	V_{IL}		0		0.4	V
SCL/SDA input logic high	V_{IH}		1.2			V
SCL/SDA output logic low	V_{OL}	$I_{LOAD} = 3mA$			0.4	V
SCL clock frequency ⁽⁷⁾	f_{SCL}				1000	kHz
SCL high time ⁽⁷⁾	t_{HIGH}		0.26			μs
SCL low time ⁽⁷⁾	t_{LOW}		0.5			μs
Data set-up time ⁽⁷⁾	t_{SU_DAT}		50			ns
Data hold time ⁽⁷⁾	t_{HD_DAT}		0			μs
Set-up time for repeated start ⁽⁷⁾	t_{SU_STA}		0.26			μs
Hold time for start ⁽⁷⁾	t_{HD_STA}		0.26			μs
Bus free time between a start and a stop command ⁽⁷⁾	t_{BUF}		0.5			μs
Set-up time for stop command ⁽⁷⁾	t_{SU_STO}		0.26			μs
Rising time of SCL/SDA ⁽⁷⁾	t_R		$20 + 0.1 \times C_B$		300	ns
Falling time of SCL/SDA ⁽⁷⁾	t_F		$20 + 0.1 \times C_B$		300	ns
Pulse width of suppressed spike ⁽⁷⁾	t_{SP}		0		50	ns
Capacitance bus for each bus line ⁽⁷⁾	C_B				550	pF

Notes:

- 7) Derived from bench characterization. Not tested in production.
- 8) The power good threshold is based on the nominal output voltage.
- 9) Use the write register to set the EC parameters. See the Register Map section starting on page 44 for a detailed description.
- 10) Set V_{OUT_SCALE} to 1 when V_{OUT} is between 0.20625V and 1.8V. If V_{OUT} is between 1.8V and 3.6V, set V_{OUT_SCALE} to 2.

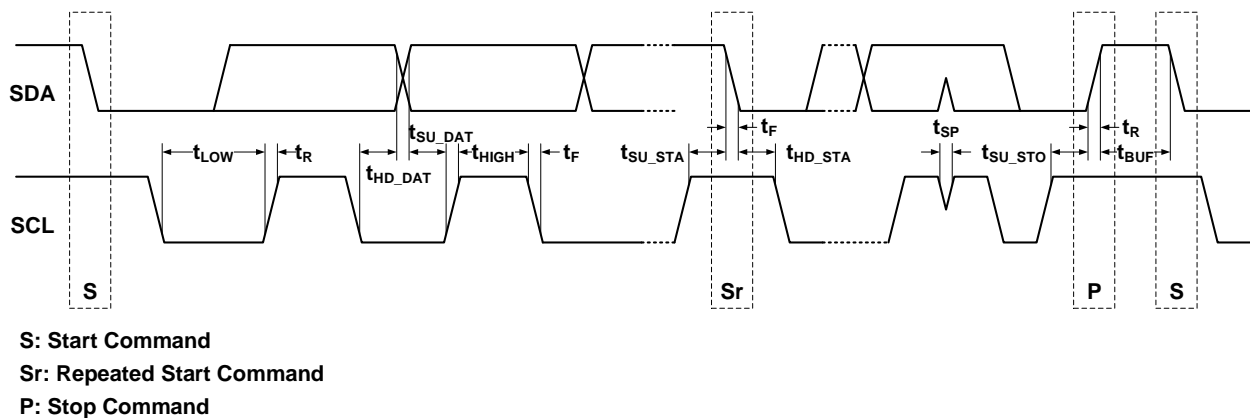
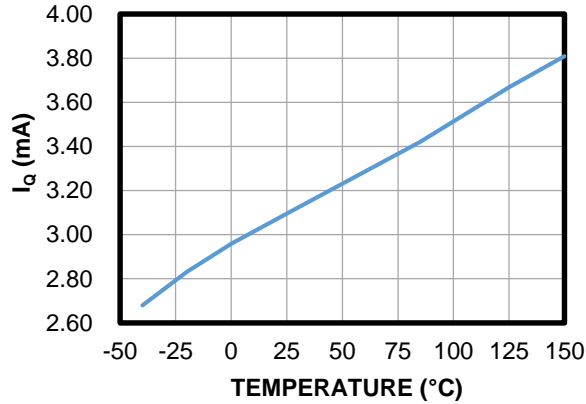

Figure 1: Digital Compatible Interface Timing Diagram

TYPICAL CHARACTERISTICS

$V_{IN} = 5V$, $T_J = -40^{\circ}C$ to $+150^{\circ}C$, unless otherwise noted.

I_Q vs. Temperature



VDRV vs. Temperature

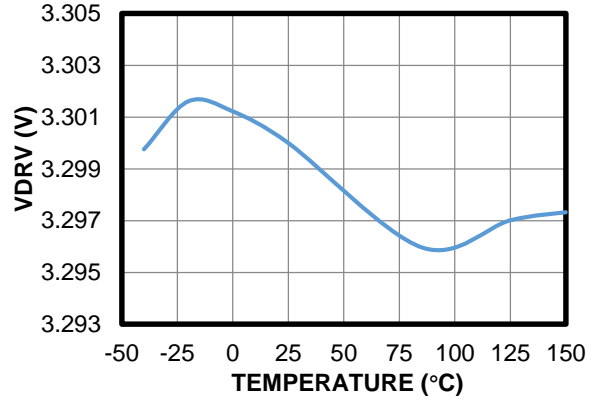

f_{sw} vs. Temperature
(CBh, bits[1:0] = 2'b00)

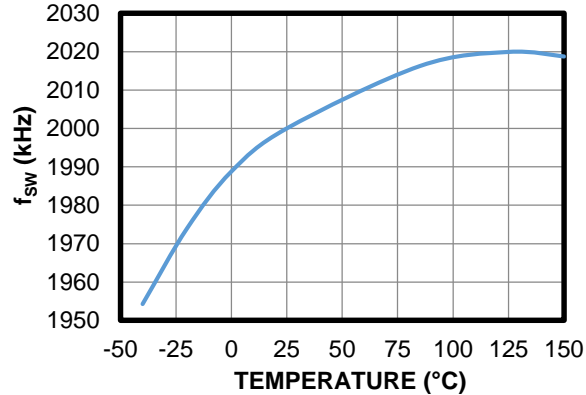

f_{sw} vs. Temperature
(CBh, bits[1:0] = 2'b01)

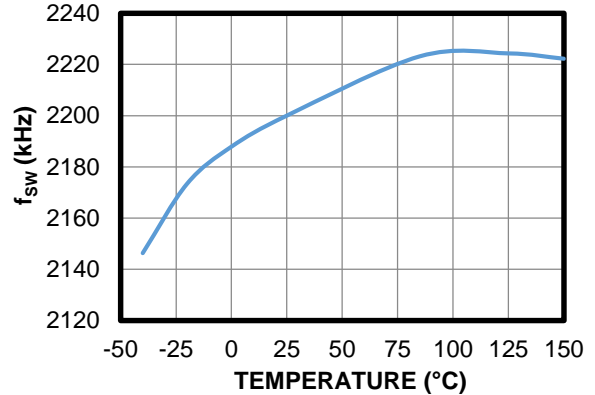

f_{sw} vs. Temperature
(CBh, bits[1:0] = 2'b10)

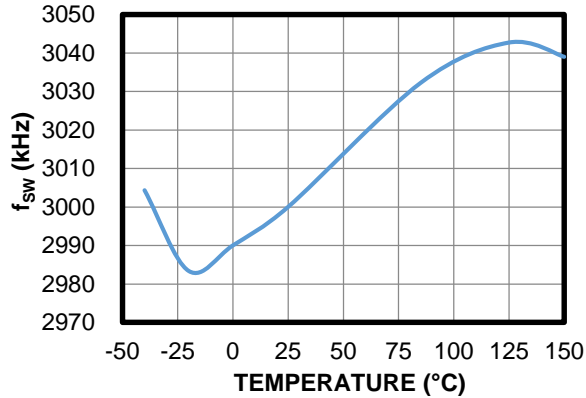

f_{sw} vs. Temperature
(CBh, bits[1:0] = 2'b11)

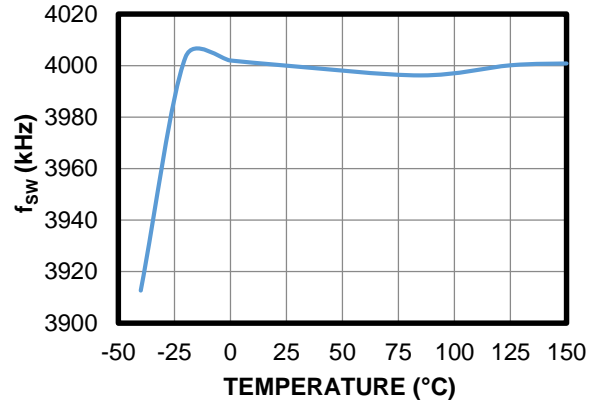

TYPICAL CHARACTERISTICS (continued)

$V_{IN} = 5V$, $T_J = -40^{\circ}C$ to $+150^{\circ}C$, unless otherwise noted.

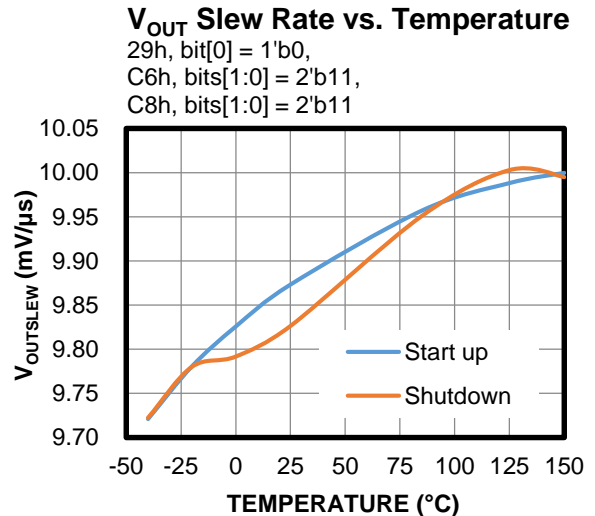
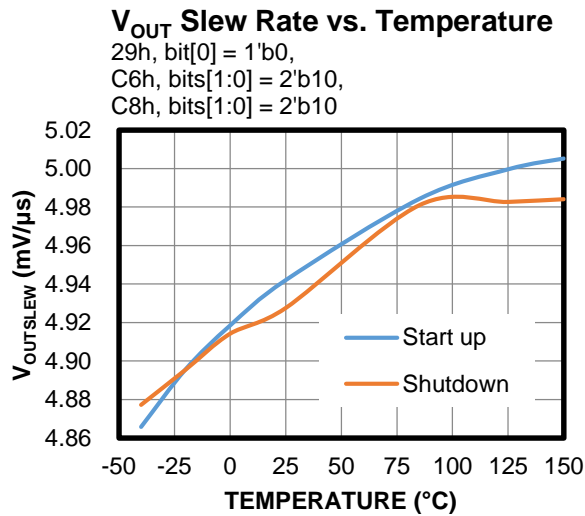
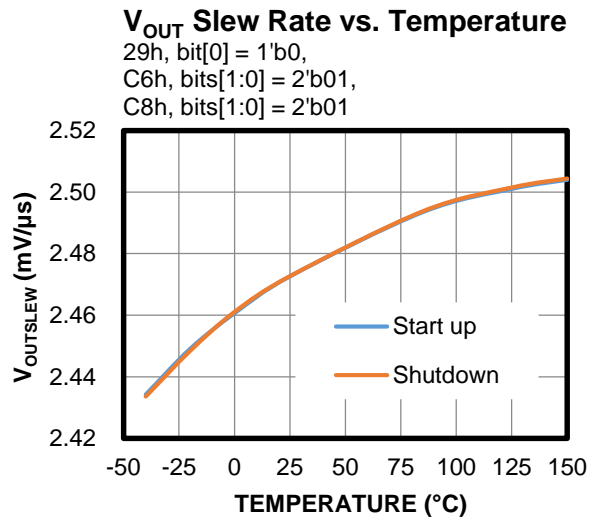
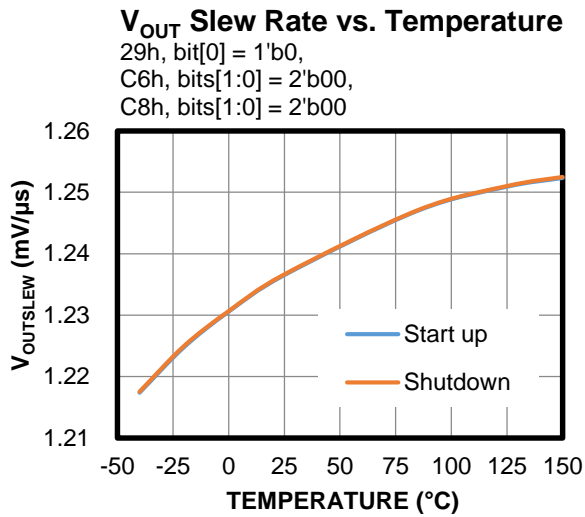
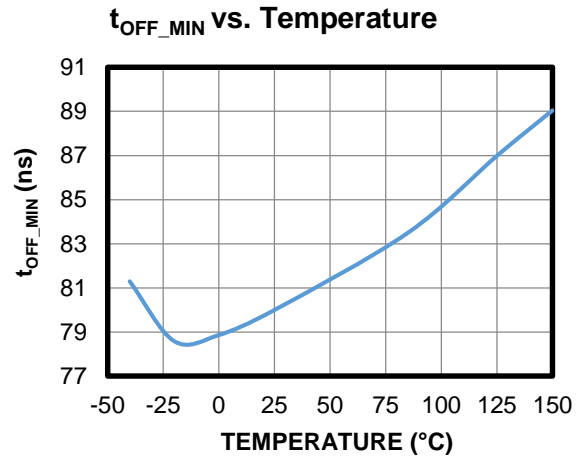
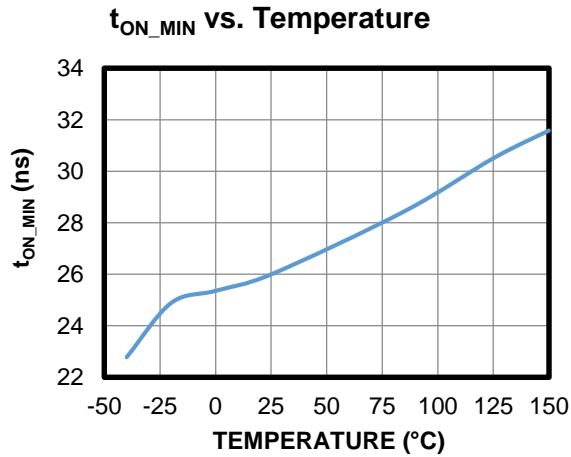

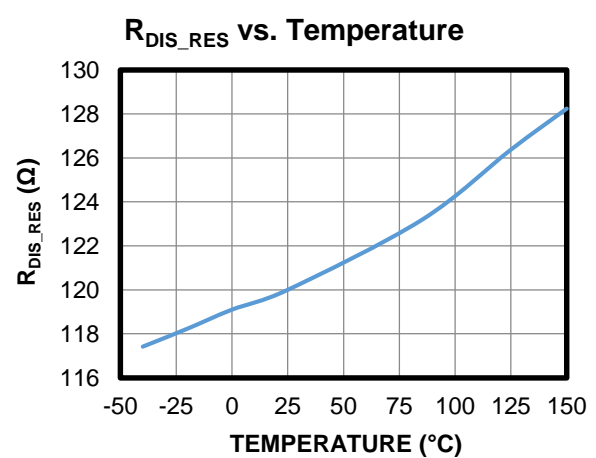
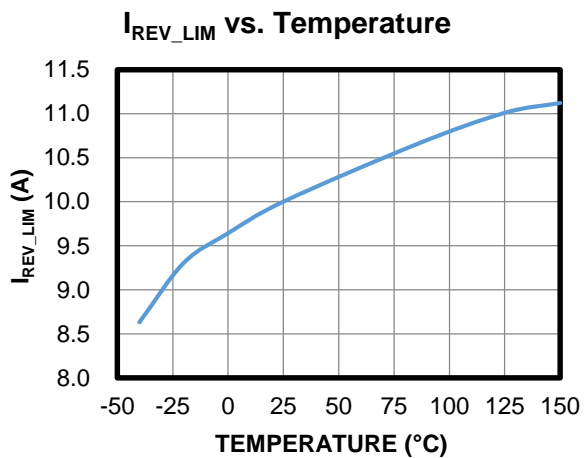
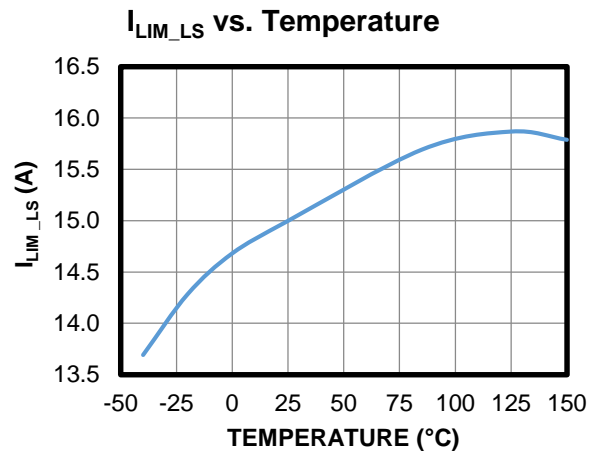
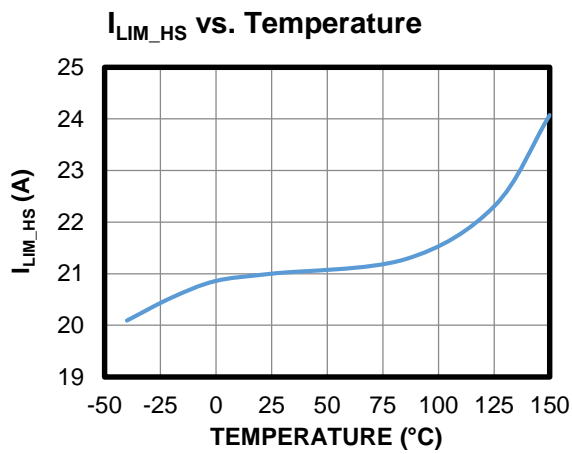
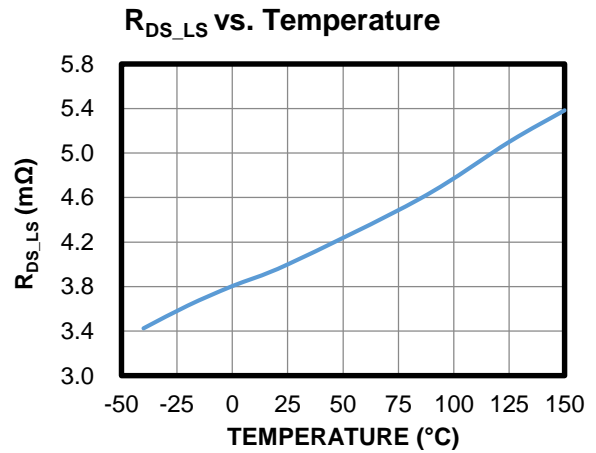
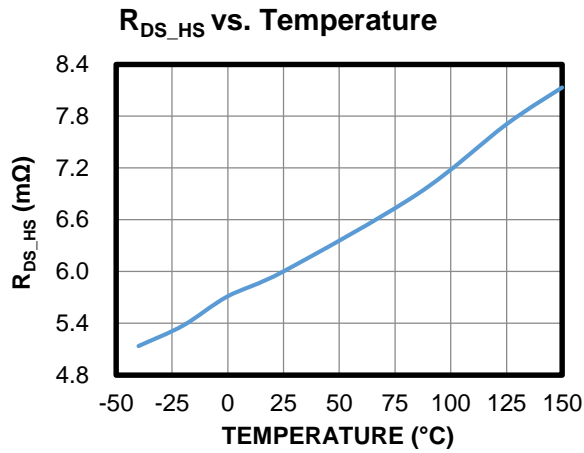
TYPICAL CHARACTERISTICS (continued)
 $V_{IN} = 5V$, $T_J = -40^{\circ}C$ to $+150^{\circ}C$, unless otherwise noted.

TYPICAL CHARACTERISTICS (continued)

$V_{IN} = 5V$, $T_J = -40^{\circ}C$ to $+150^{\circ}C$, unless otherwise noted.

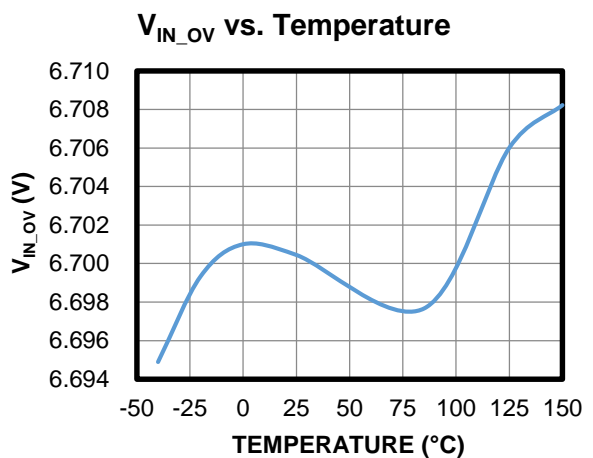
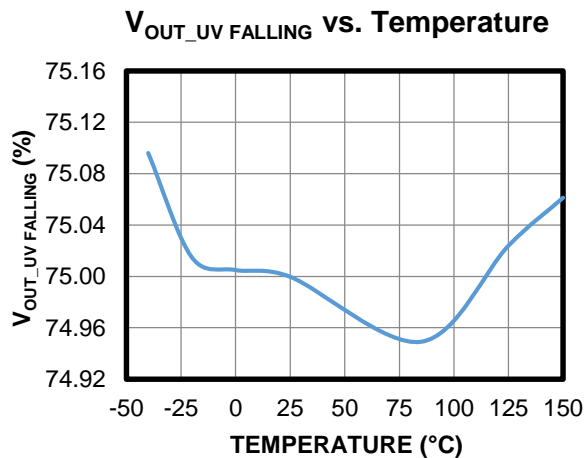
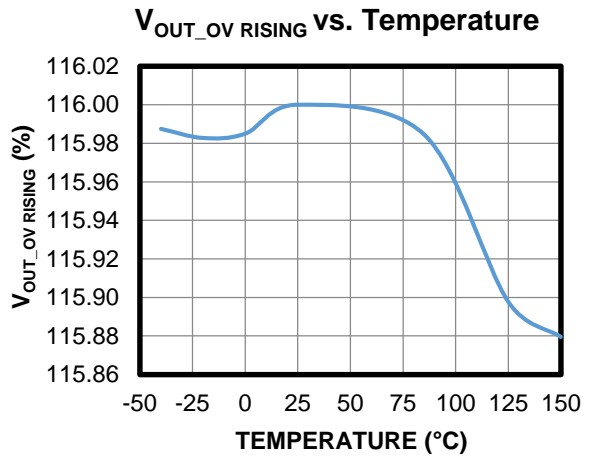
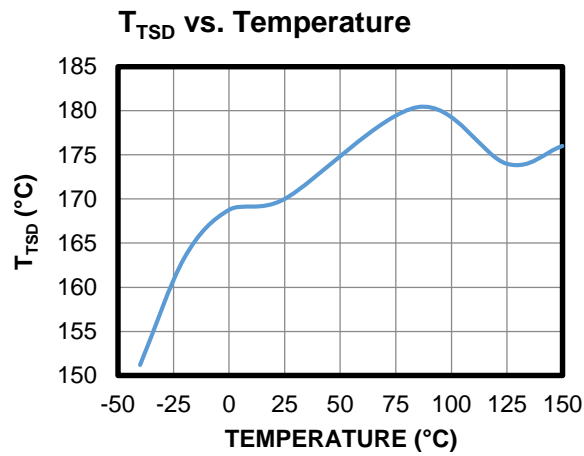
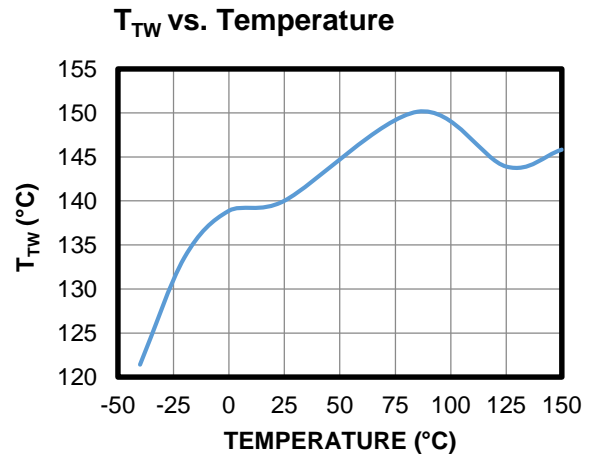
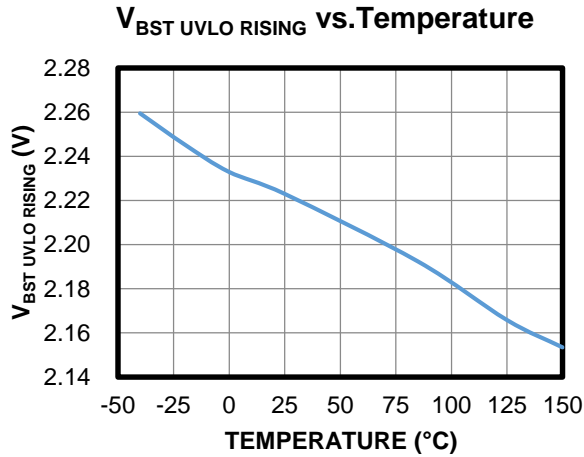

TYPICAL CHARACTERISTICS *(continued)*

$V_{IN} = 5V$, $T_J = -40^{\circ}C$ to $+150^{\circ}C$, unless otherwise noted.

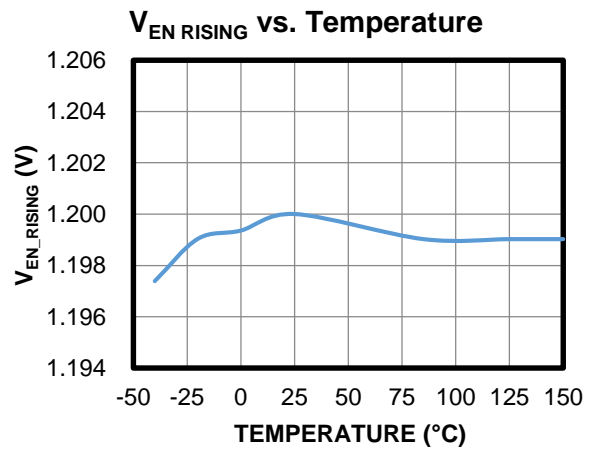
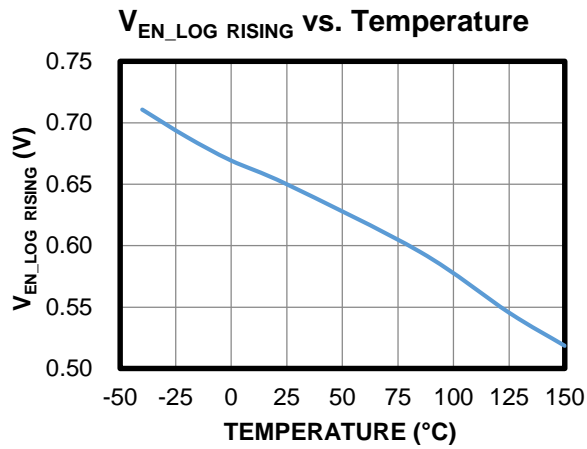

TYPICAL PERFORMANCE CHARACTERISTICS

$V_{IN} = 5V$, $V_{OUT} = 0.75V$, $L = 100nH$, $C_{OUT} = 4 \times 47\mu F$, $f_{SW} = 3MHz$, DCM, $T_A = 25^\circ C$, unless otherwise noted.

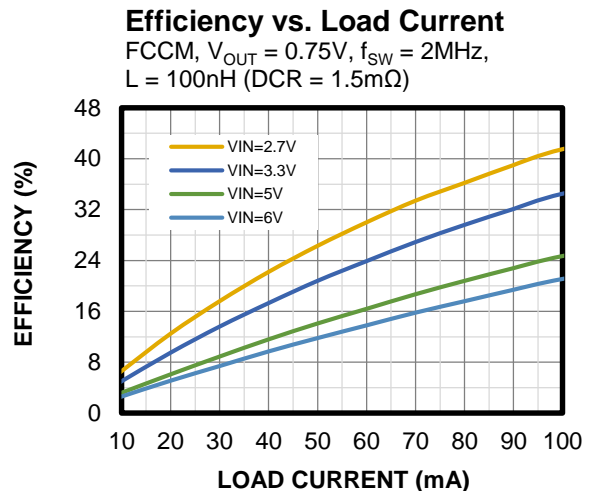
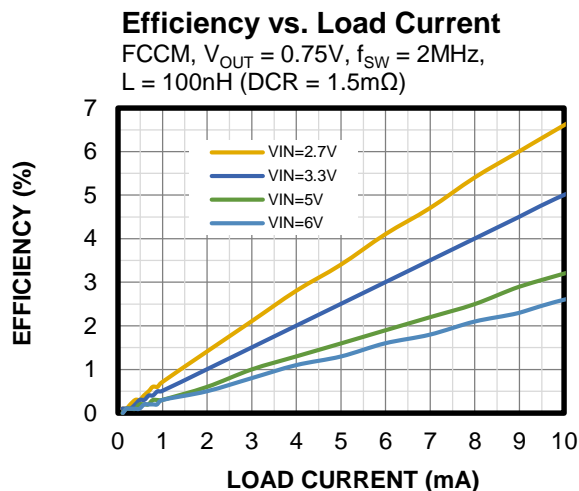
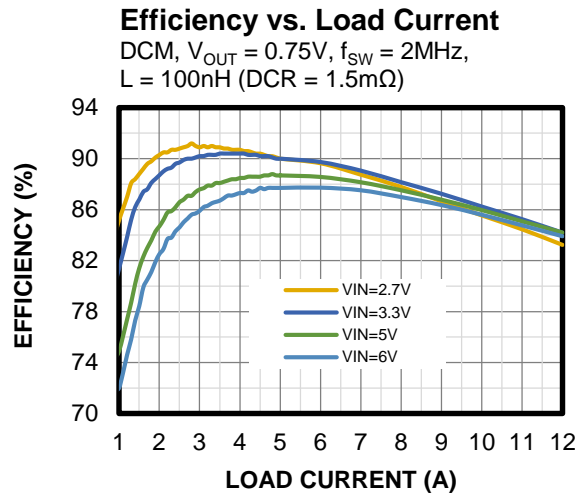
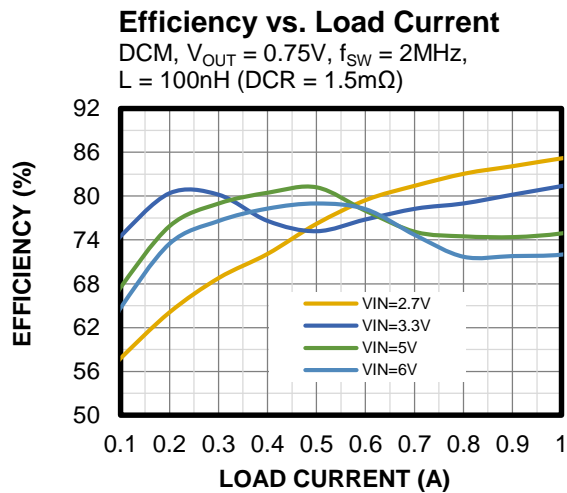
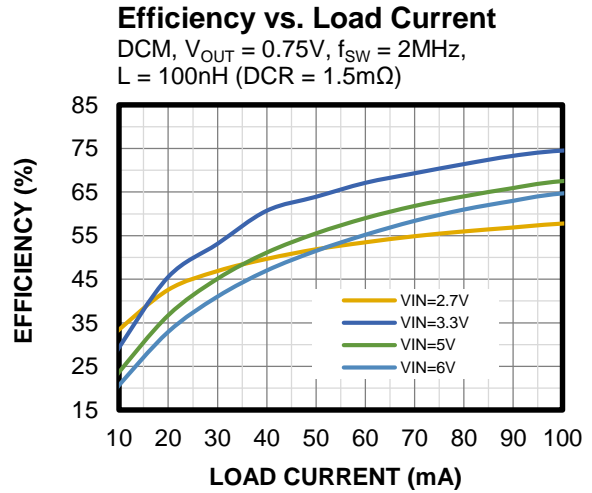
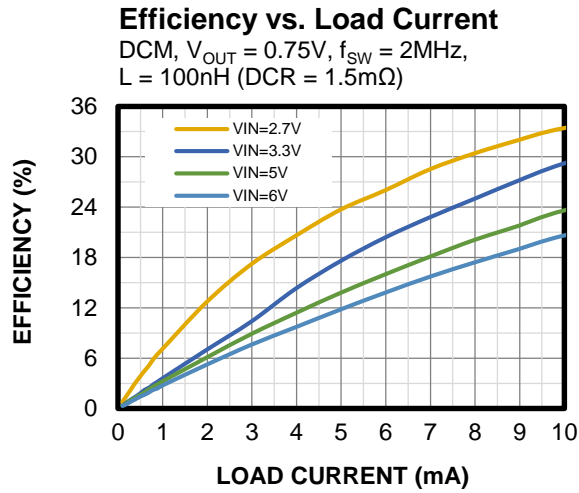

TYPICAL PERFORMANCE CHARACTERISTICS (continued)

$V_{IN} = 5V$, $V_{OUT} = 0.75V$, $L = 100nH$, $C_{OUT} = 4 \times 47\mu F$, $f_{SW} = 3MHz$, DCM, $T_A = 25^\circ C$, unless otherwise noted.

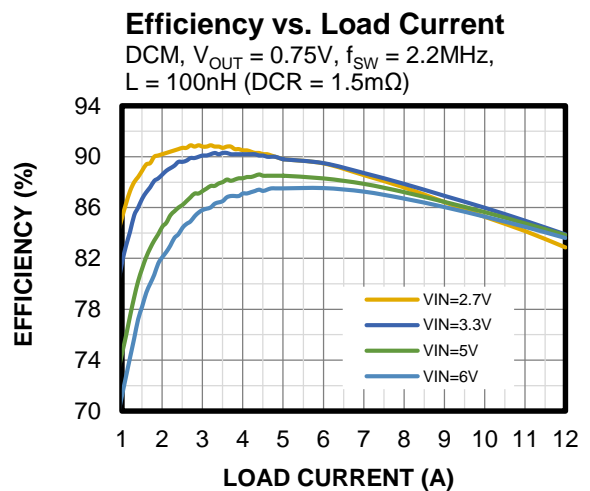
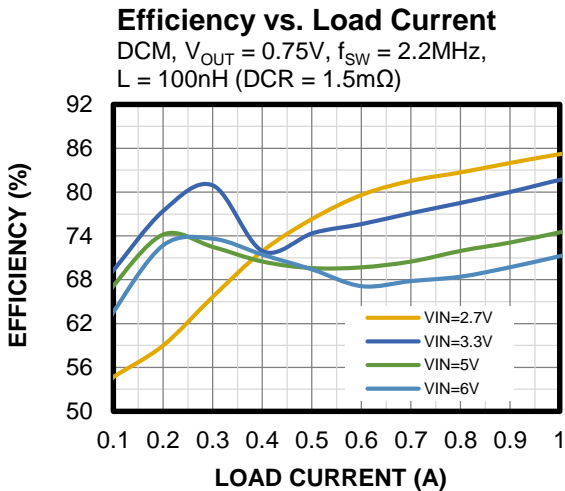
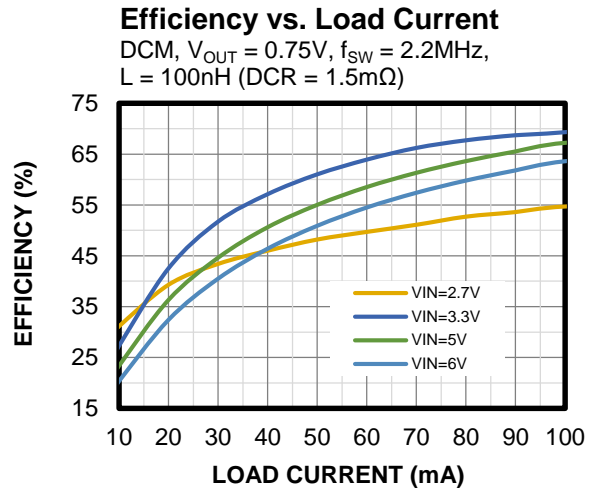
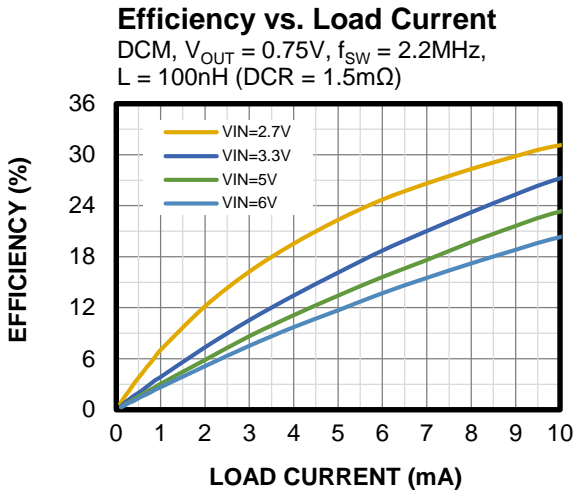
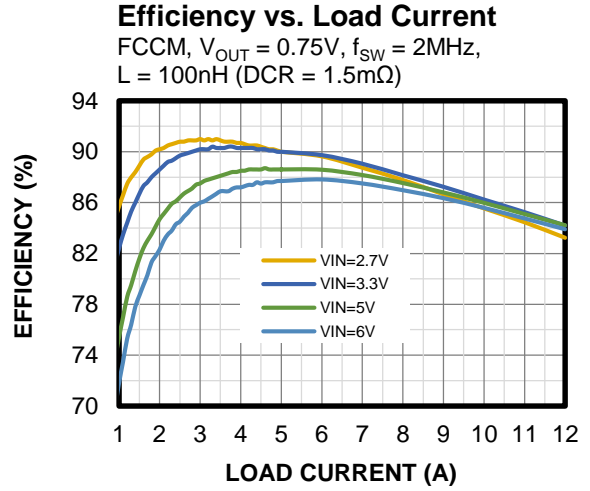
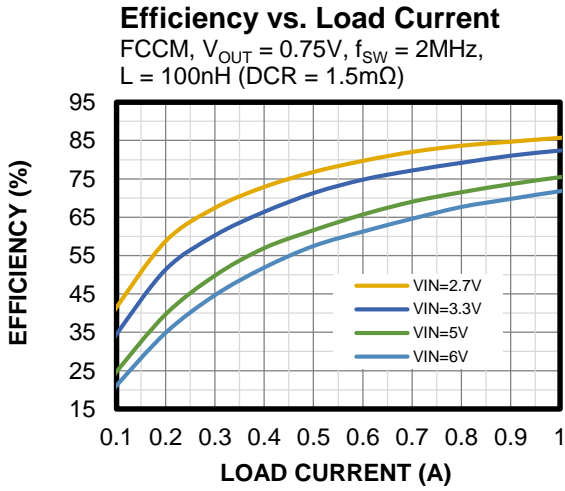

TYPICAL PERFORMANCE CHARACTERISTICS (continued)

$V_{IN} = 5V$, $V_{OUT} = 0.75V$, $L = 100nH$, $C_{OUT} = 4 \times 47\mu F$, $f_{SW} = 3MHz$, DCM, $T_A = 25^\circ C$, unless otherwise noted.

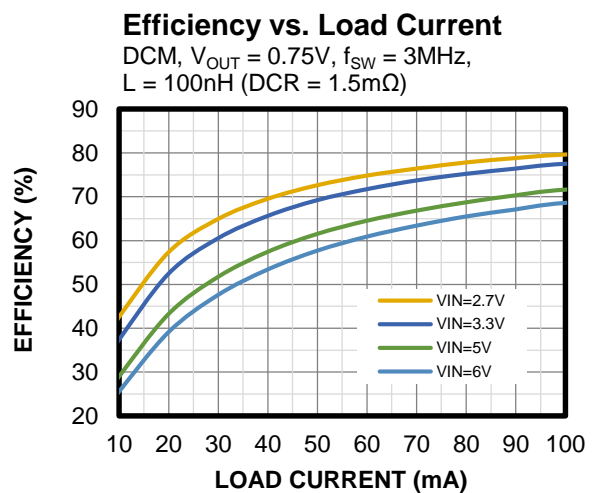
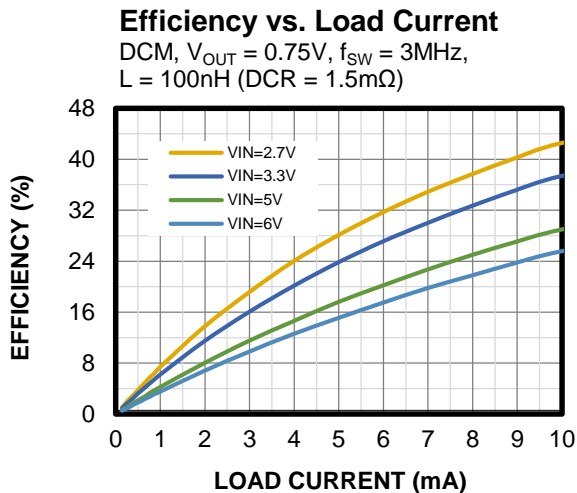
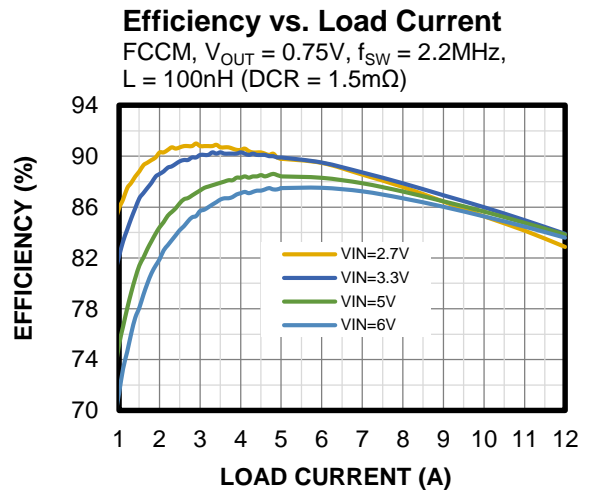
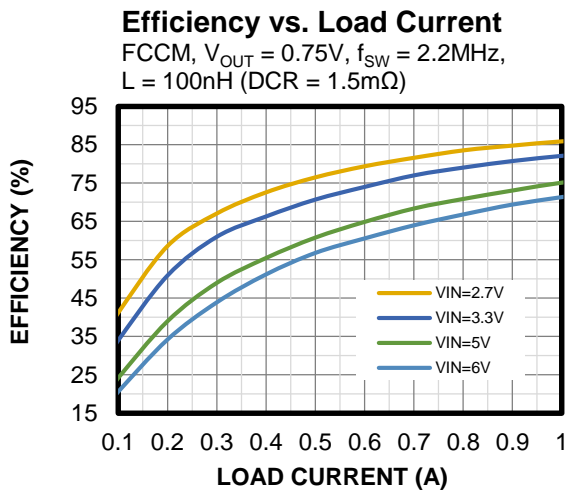
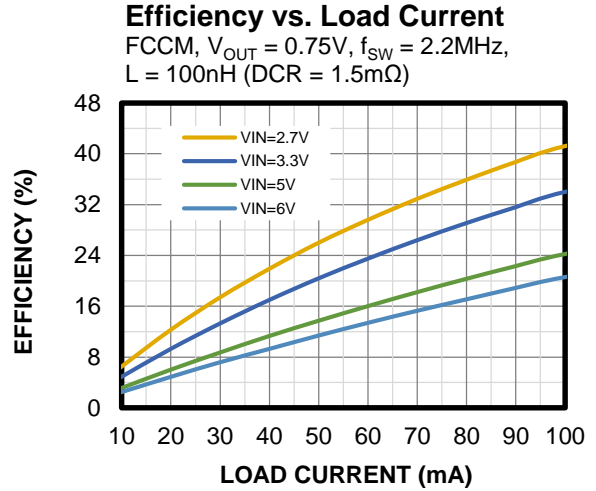
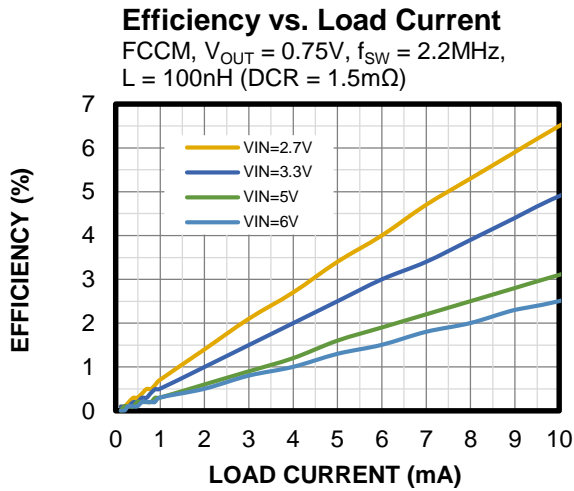

TYPICAL PERFORMANCE CHARACTERISTICS (continued)

$V_{IN} = 5V$, $V_{OUT} = 0.75V$, $L = 100nH$, $C_{OUT} = 4 \times 47\mu F$, $f_{SW} = 3MHz$, DCM, $T_A = 25^\circ C$, unless otherwise noted.

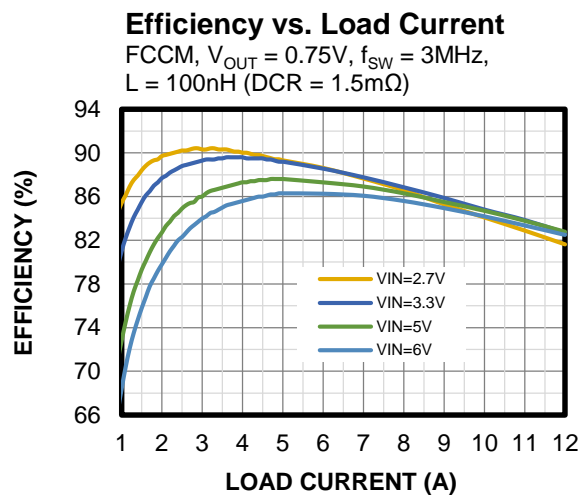
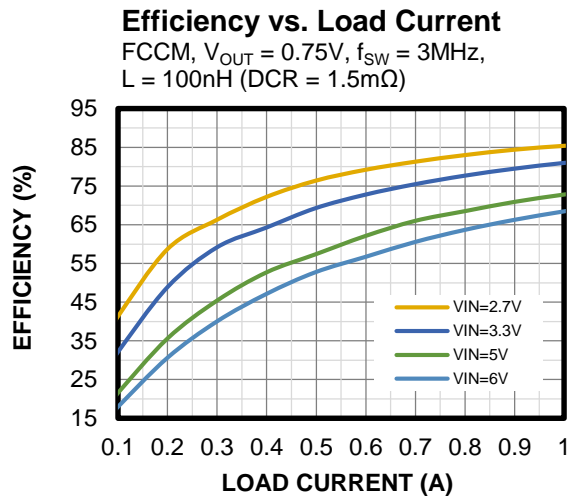
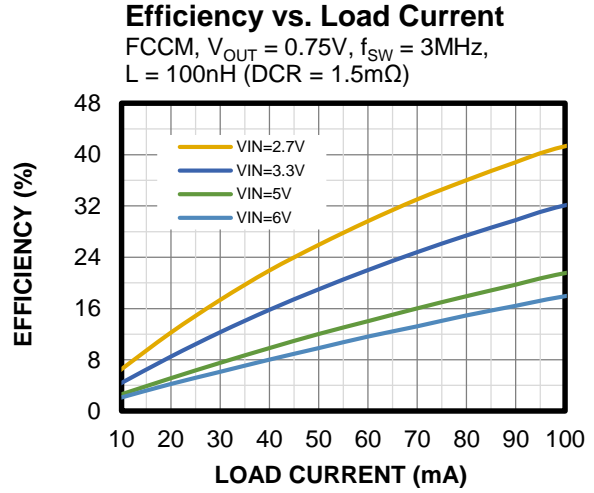
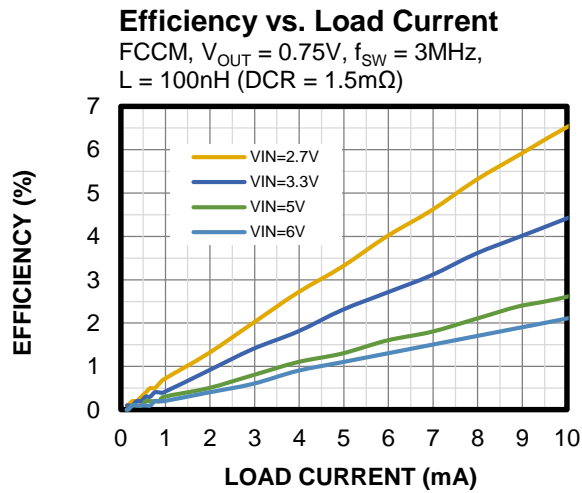
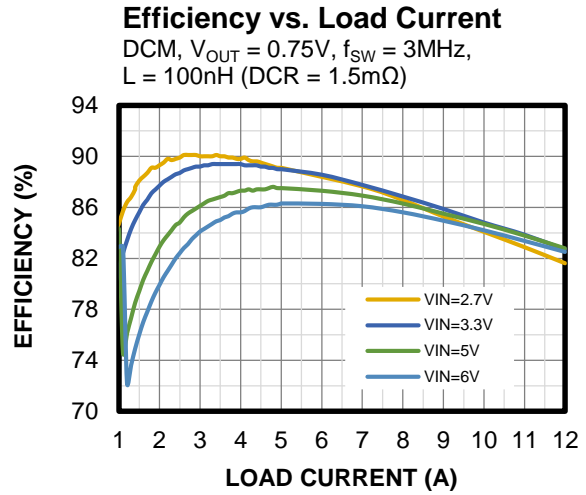
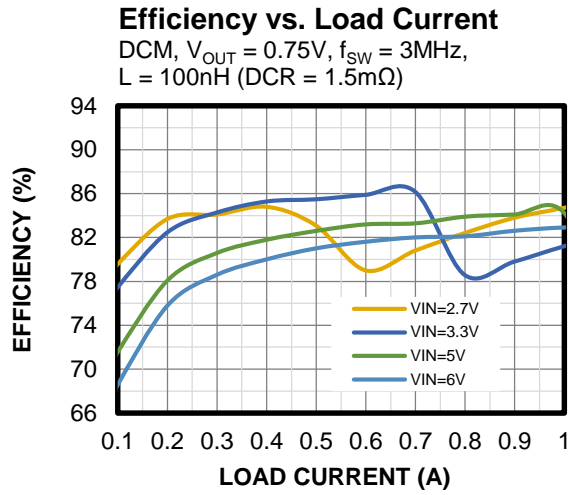

TYPICAL PERFORMANCE CHARACTERISTICS (continued)

$V_{IN} = 5V$, $V_{OUT} = 0.75V$, $L = 100nH$, $C_{OUT} = 4 \times 47\mu F$, $f_{SW} = 3MHz$, DCM, $T_A = 25^\circ C$, unless otherwise noted.

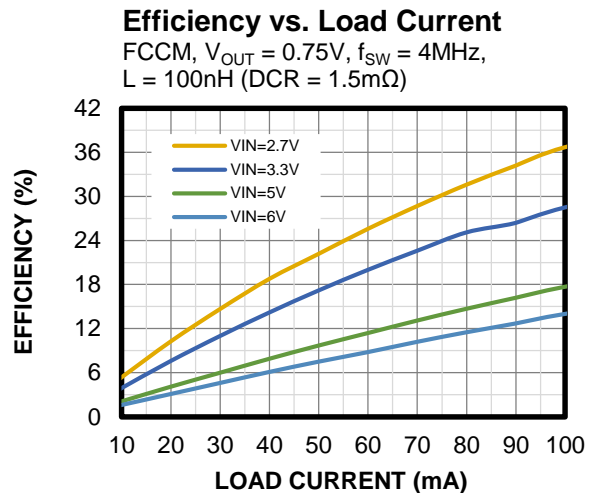
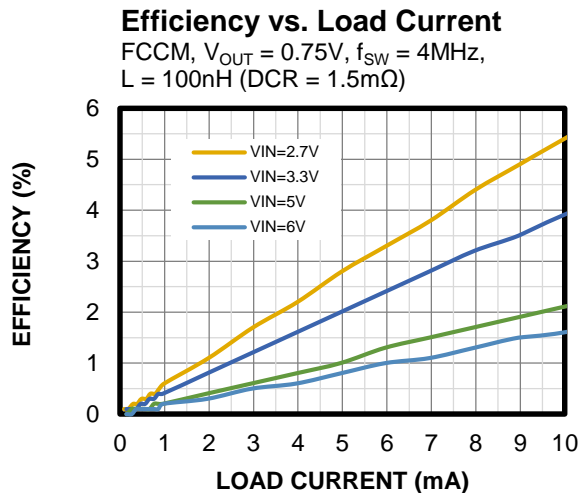
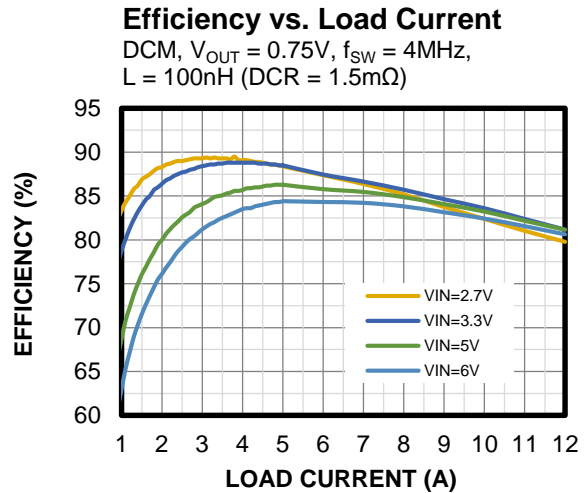
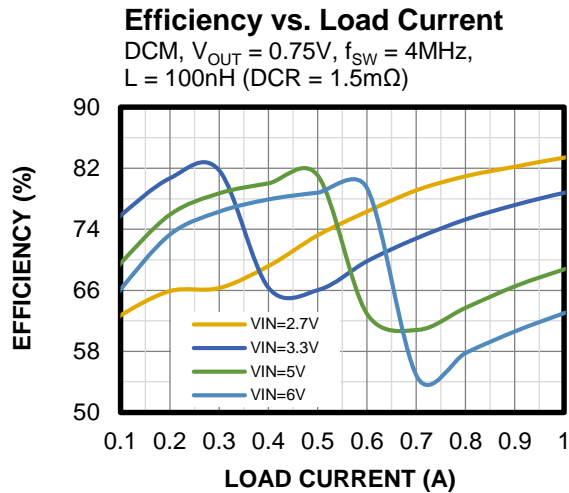
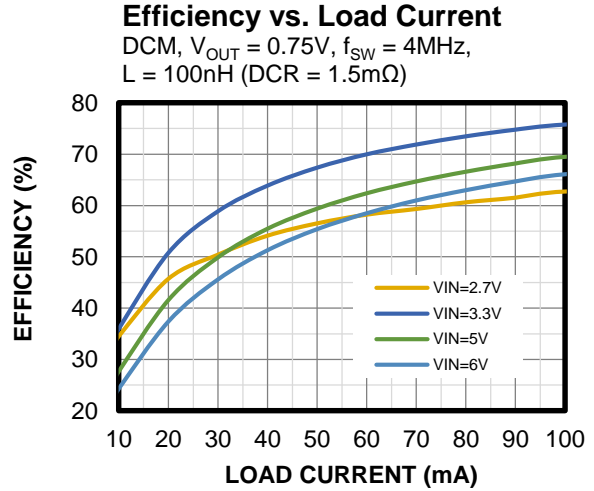
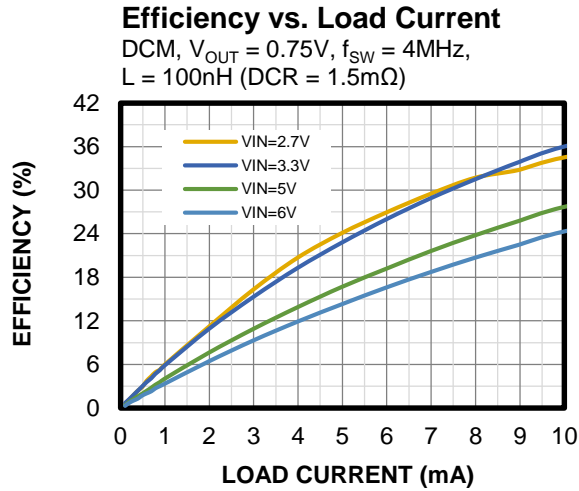

TYPICAL PERFORMANCE CHARACTERISTICS (continued)

$V_{IN} = 5V$, $V_{OUT} = 0.75V$, $L = 100nH$, $C_{OUT} = 4 \times 47\mu F$, $f_{SW} = 3MHz$, DCM, $T_A = 25^\circ C$, unless otherwise noted.

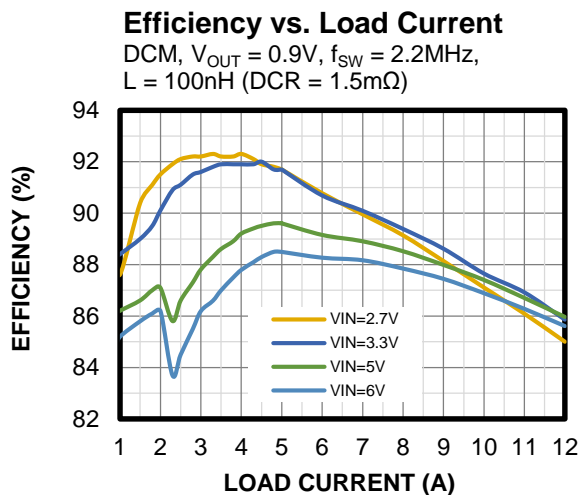
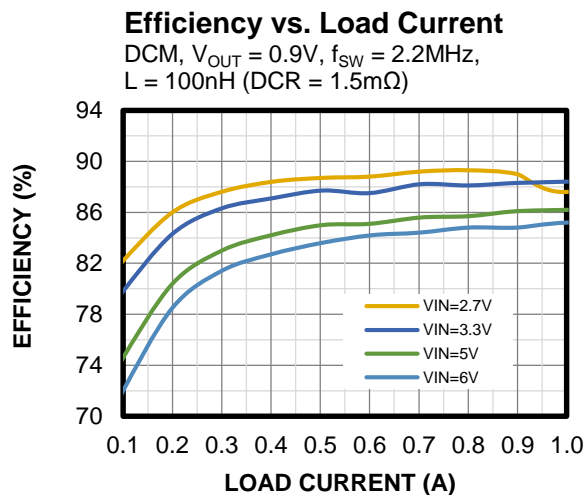
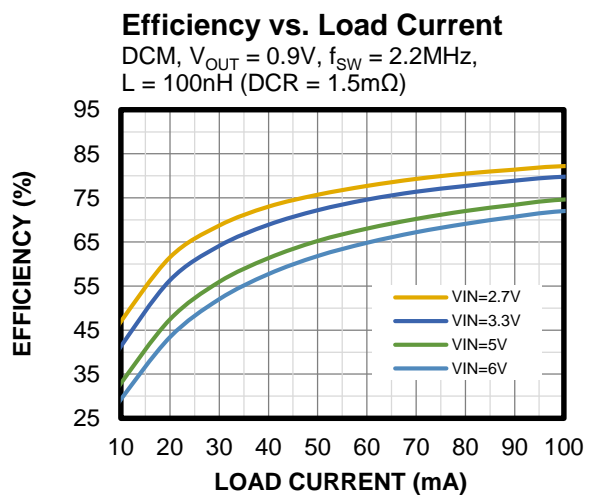
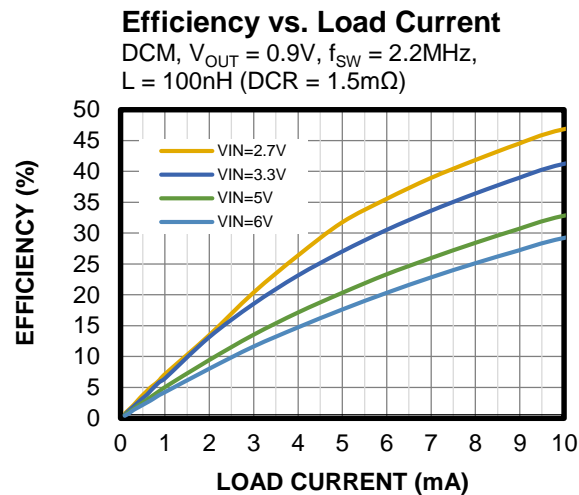
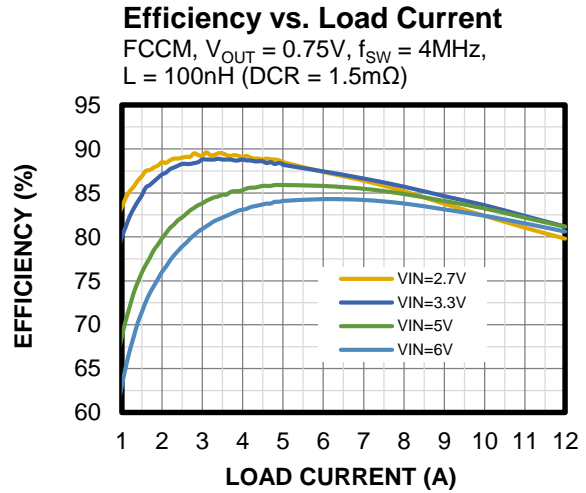
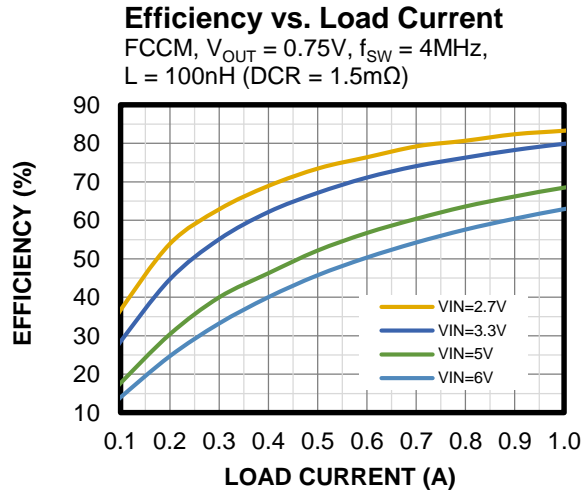

TYPICAL PERFORMANCE CHARACTERISTICS (continued)

$V_{IN} = 5V$, $V_{OUT} = 0.75V$, $L = 100nH$, $C_{OUT} = 4 \times 47\mu F$, $f_{SW} = 3MHz$, DCM, $T_A = 25^\circ C$, unless otherwise noted.

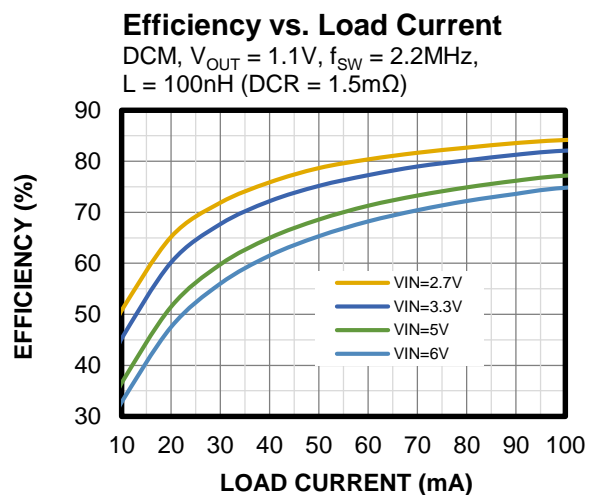
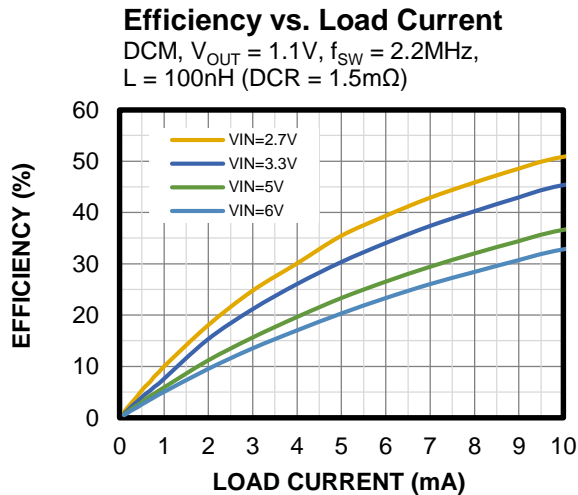
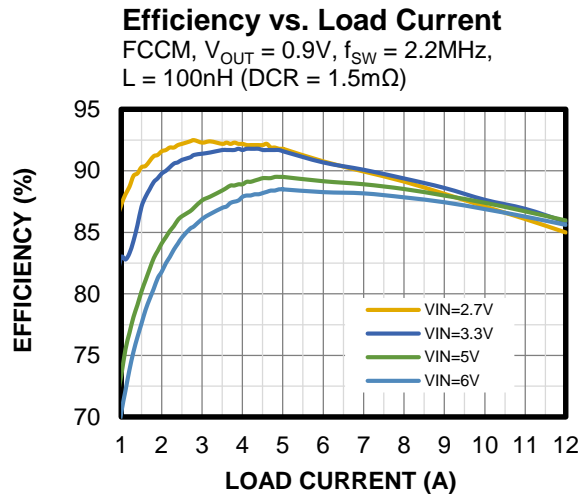
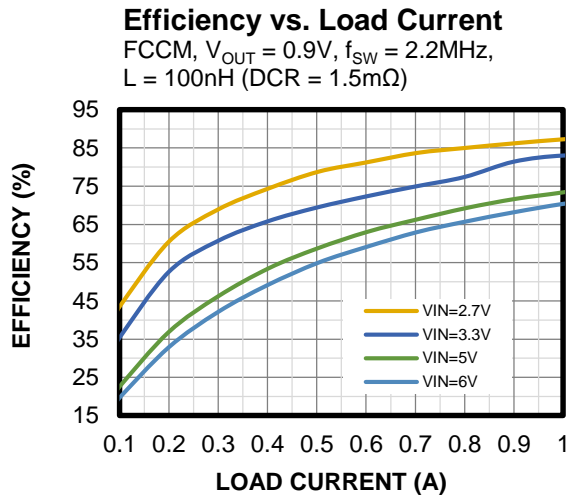
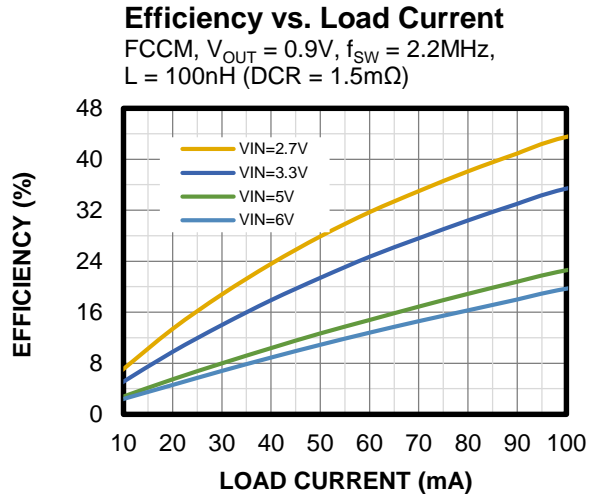
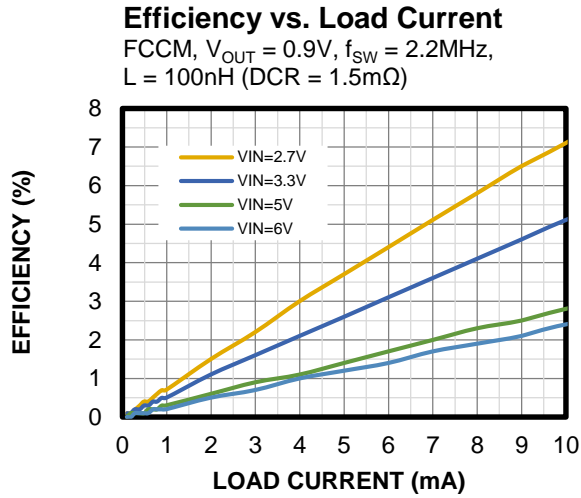

TYPICAL PERFORMANCE CHARACTERISTICS (continued)

$V_{IN} = 5V$, $V_{OUT} = 0.75V$, $L = 100nH$, $C_{OUT} = 4 \times 47\mu F$, $f_{SW} = 3MHz$, DCM, $T_A = 25^\circ C$, unless otherwise noted.

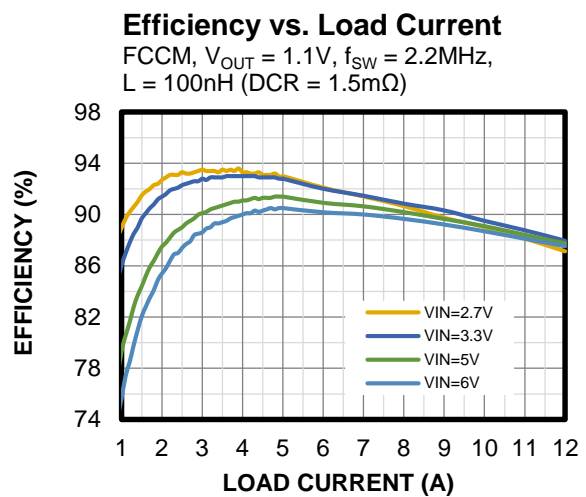
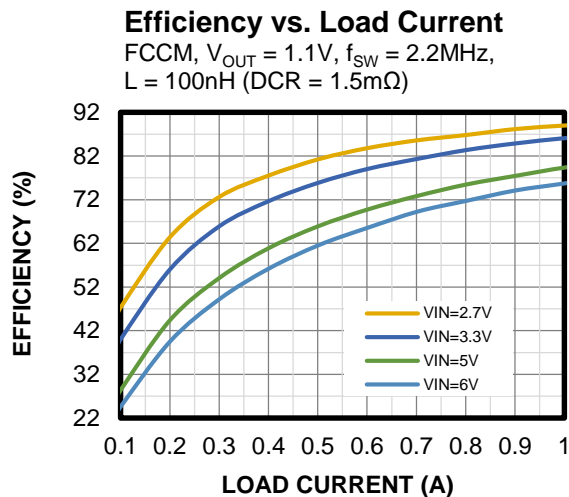
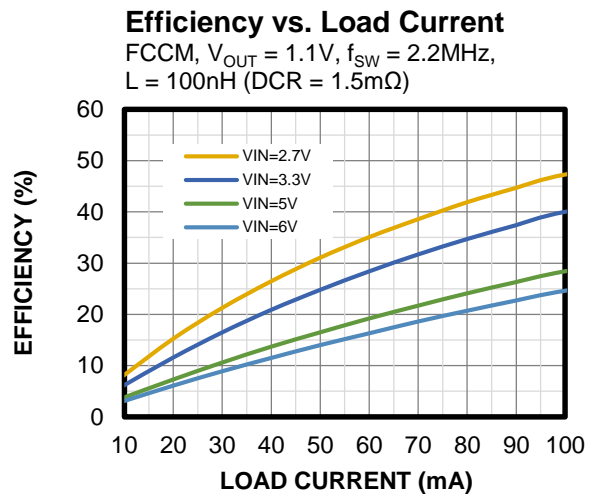
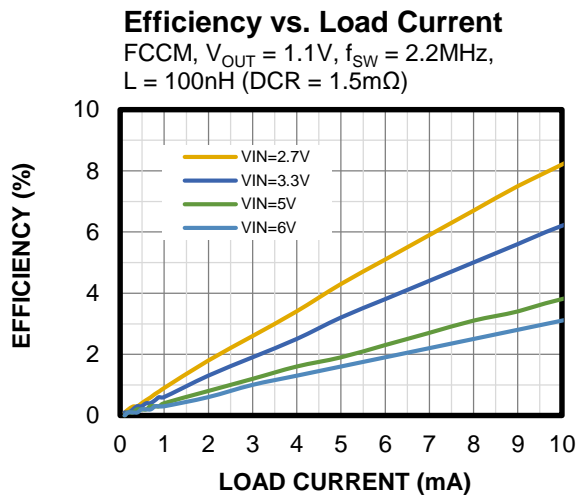
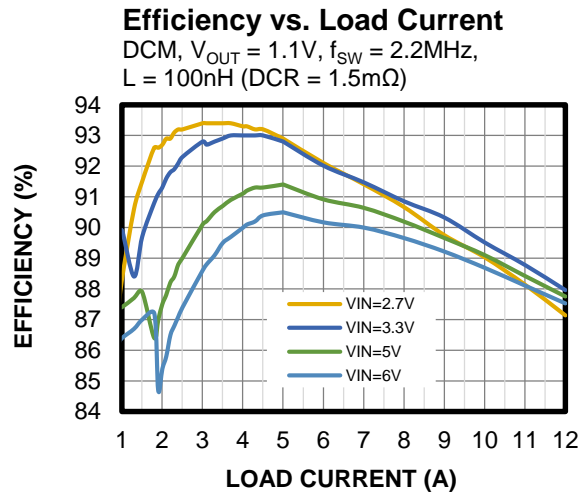
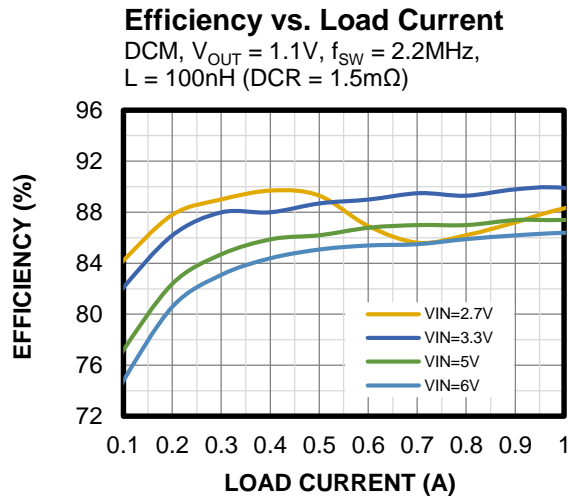

TYPICAL PERFORMANCE CHARACTERISTICS (continued)

$V_{IN} = 5V$, $V_{OUT} = 0.75V$, $L = 100nH$, $C_{OUT} = 4 \times 47\mu F$, $f_{SW} = 3MHz$, DCM, $T_A = 25^\circ C$, unless otherwise noted.

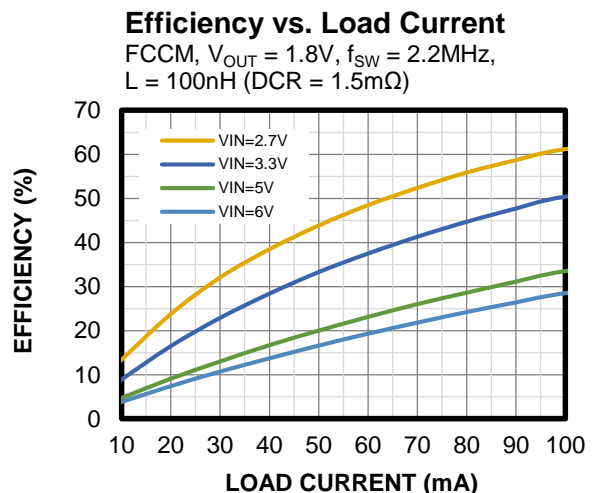
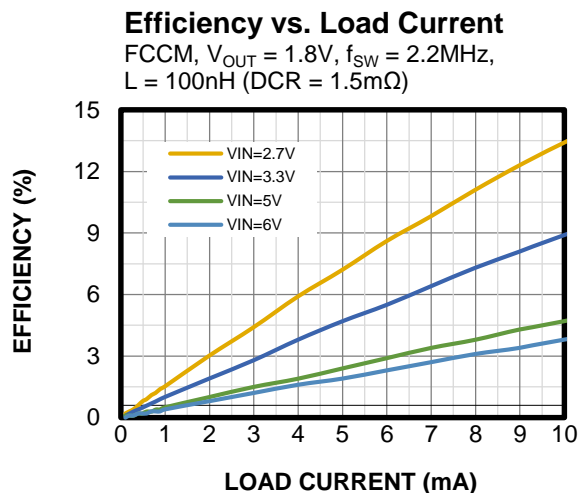
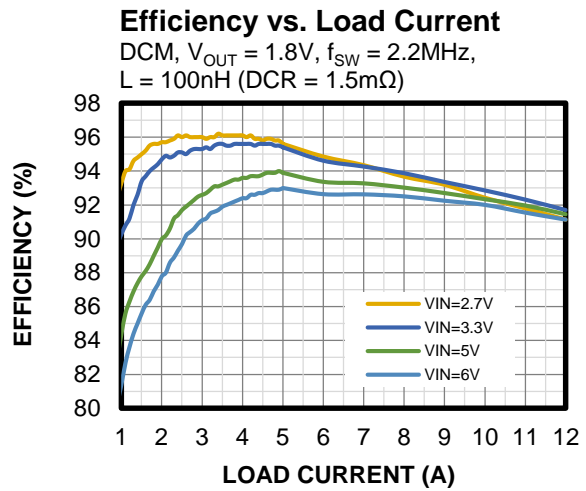
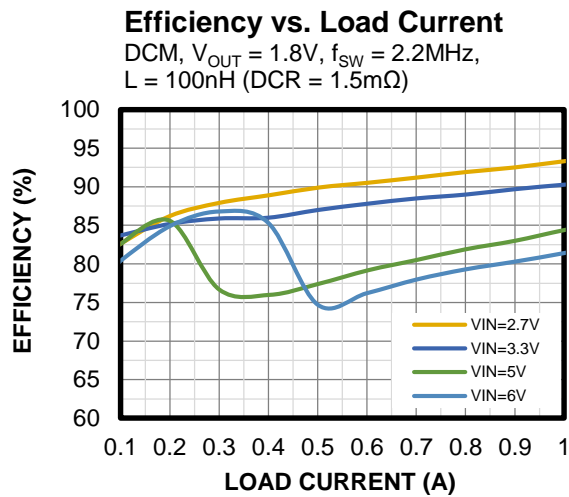
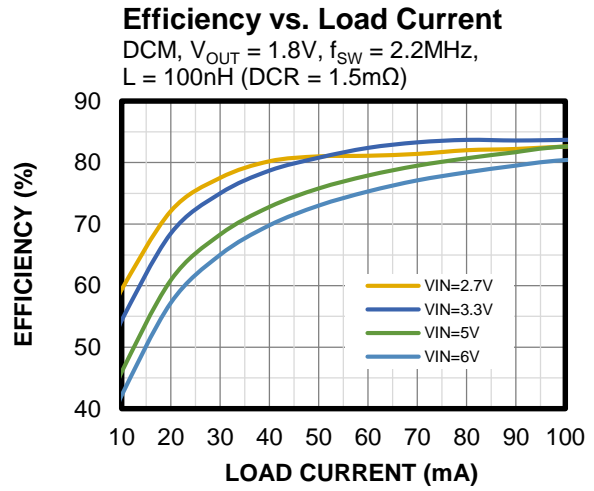
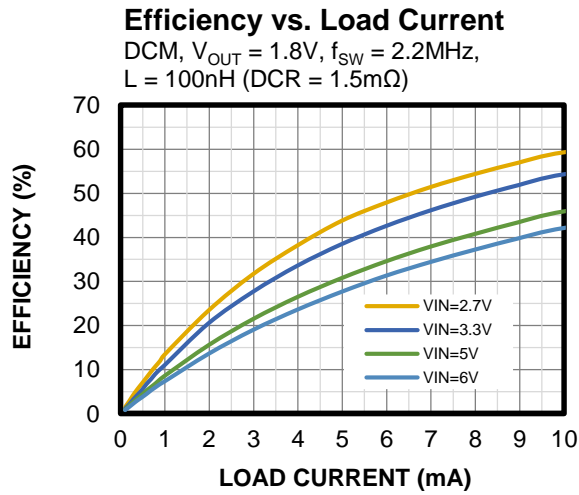

TYPICAL PERFORMANCE CHARACTERISTICS (continued)

$V_{IN} = 5V$, $V_{OUT} = 0.75V$, $L = 100nH$, $C_{OUT} = 4 \times 47\mu F$, $f_{SW} = 3MHz$, DCM, $T_A = 25^\circ C$, unless otherwise noted.

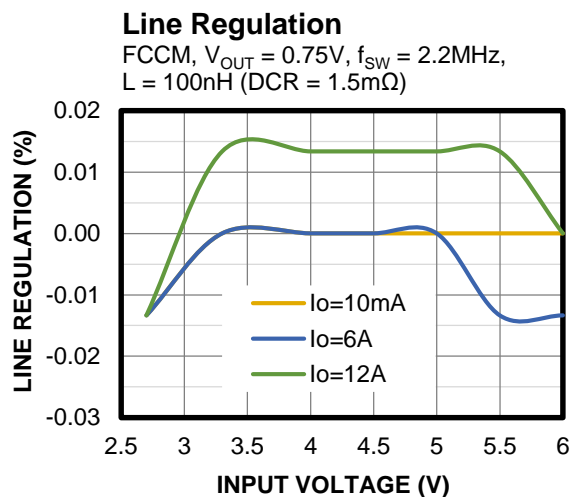
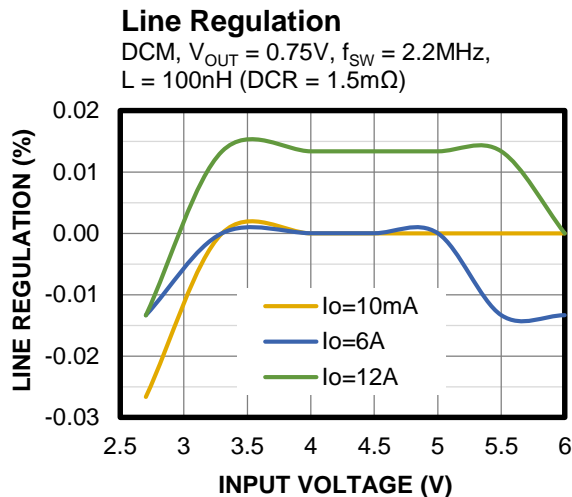
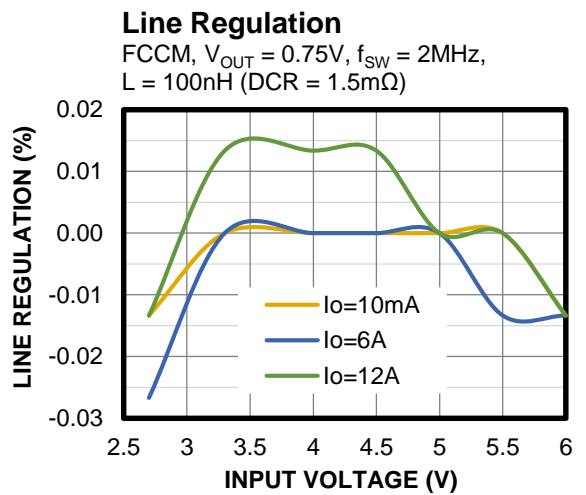
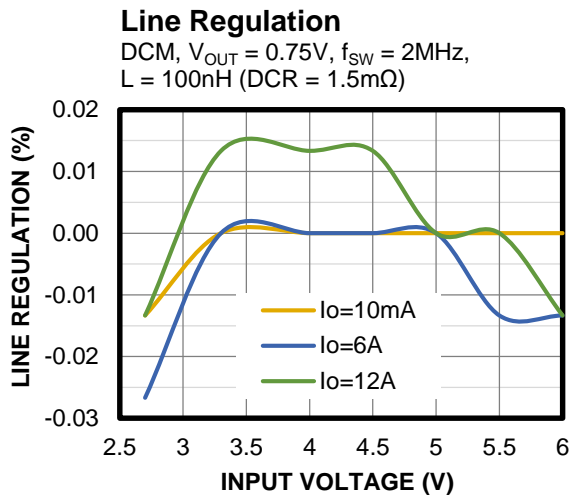
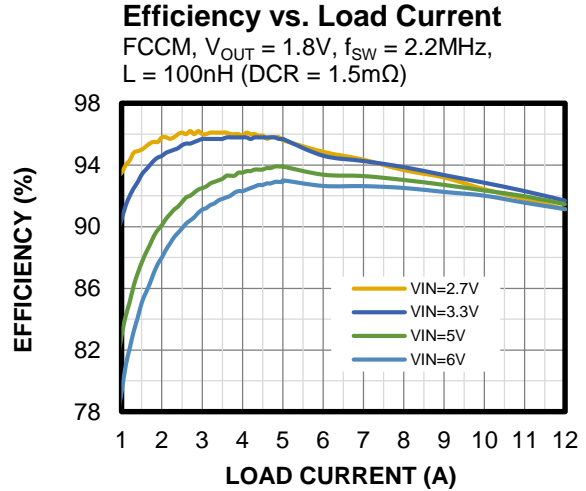
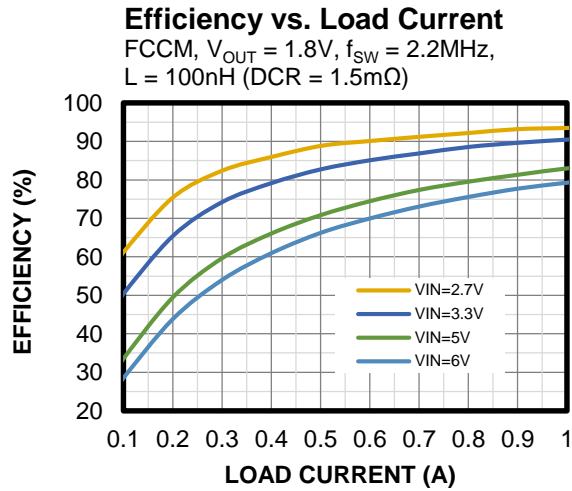

TYPICAL PERFORMANCE CHARACTERISTICS (continued)

$V_{IN} = 5V$, $V_{OUT} = 0.75V$, $L = 100nH$, $C_{OUT} = 4 \times 47\mu F$, $f_{SW} = 3MHz$, DCM, $T_A = 25^\circ C$, unless otherwise noted.

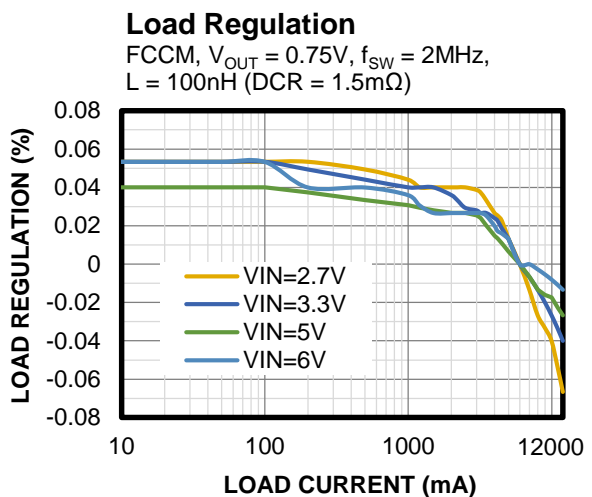
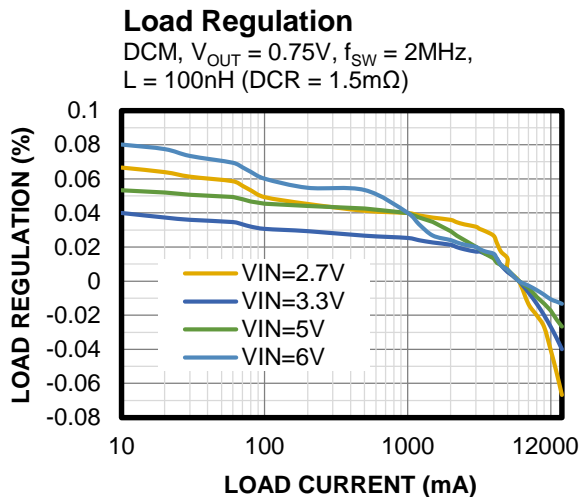
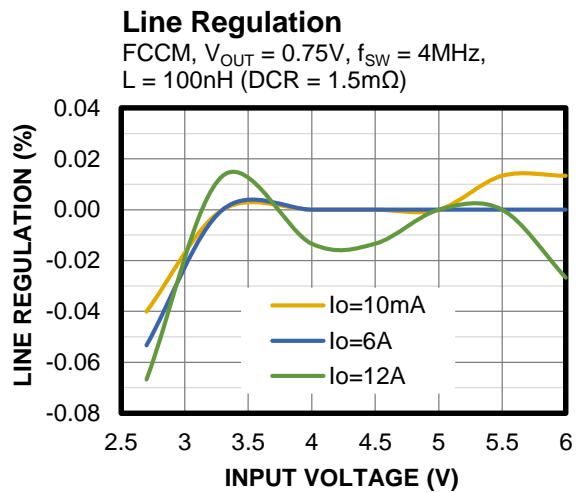
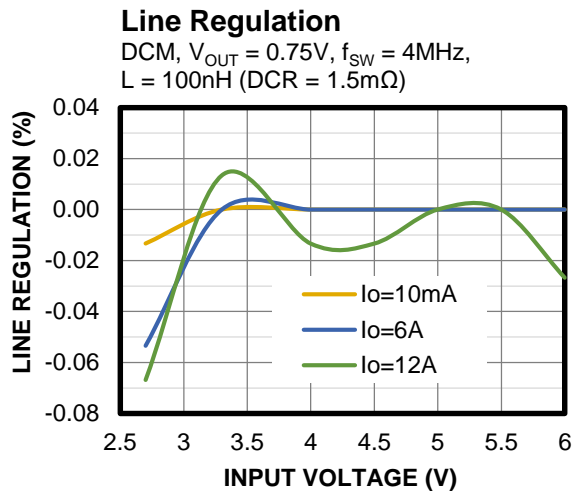
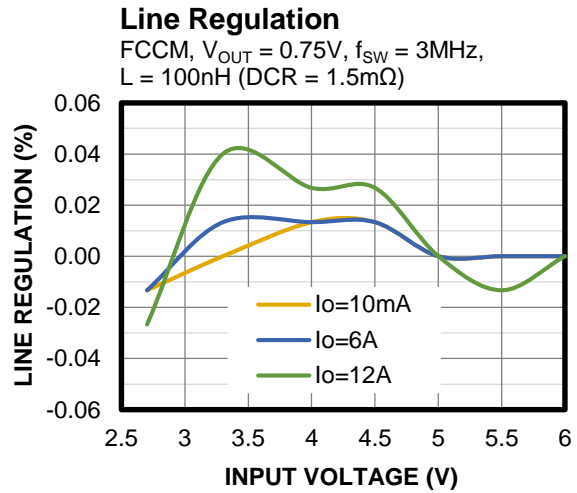
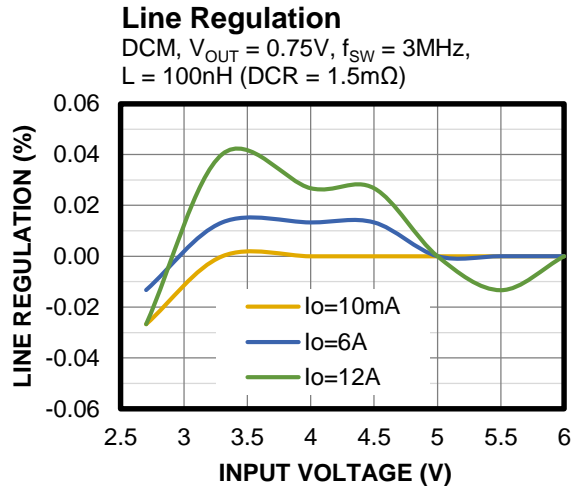

TYPICAL PERFORMANCE CHARACTERISTICS (continued)

$V_{IN} = 5V$, $V_{OUT} = 0.75V$, $L = 100nH$, $C_{OUT} = 4 \times 47\mu F$, $f_{SW} = 3MHz$, DCM, $T_A = 25^\circ C$, unless otherwise noted.

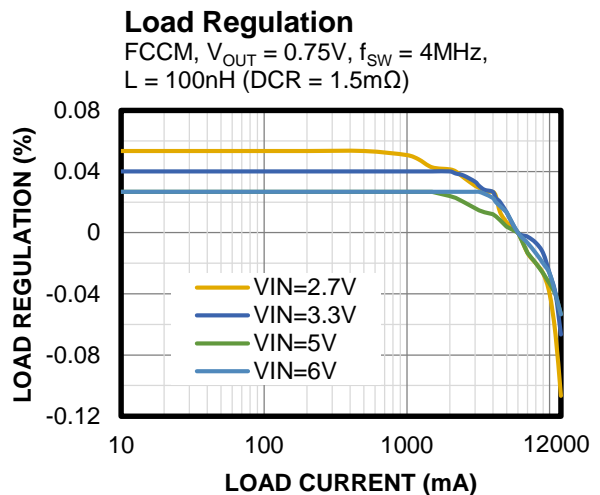
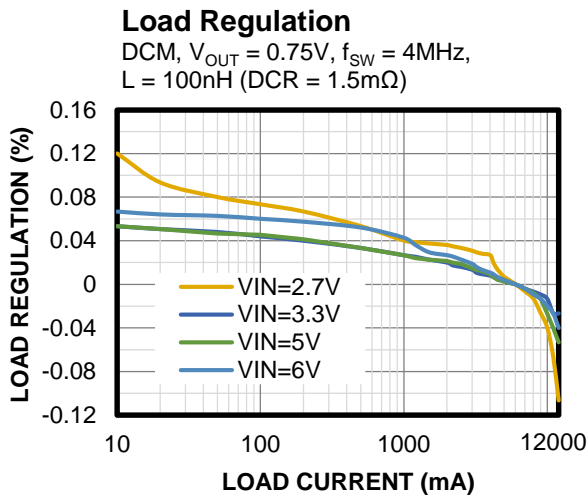
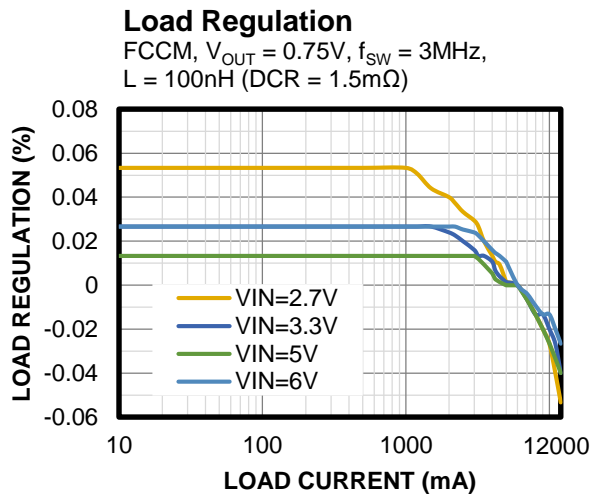
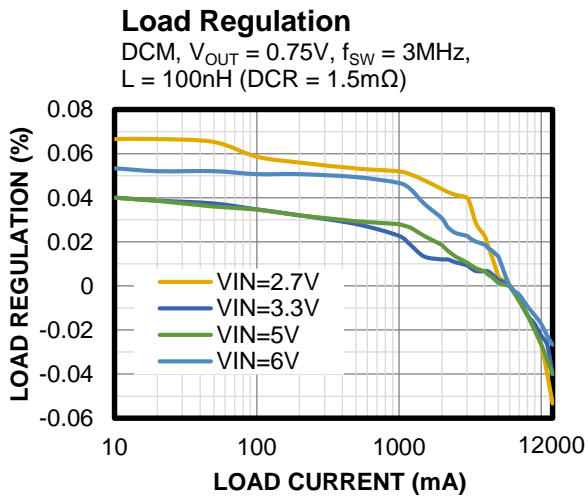
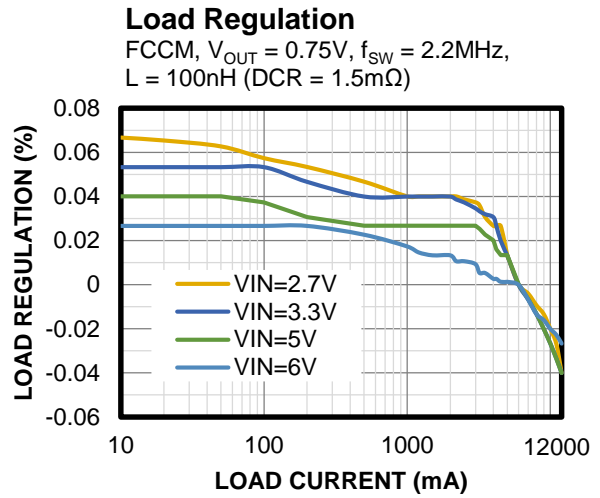
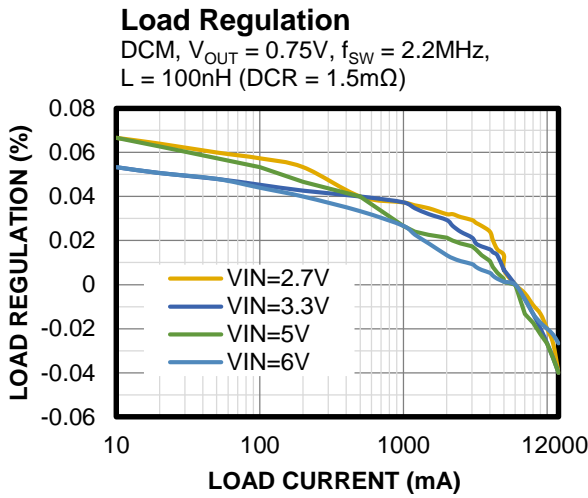

TYPICAL PERFORMANCE CHARACTERISTICS (continued)

$V_{IN} = 5V$, $V_{OUT} = 0.75V$, $L = 100nH$, $C_{OUT} = 4 \times 47\mu F$, $f_{SW} = 3MHz$, DCM, $T_A = 25^\circ C$, unless otherwise noted.

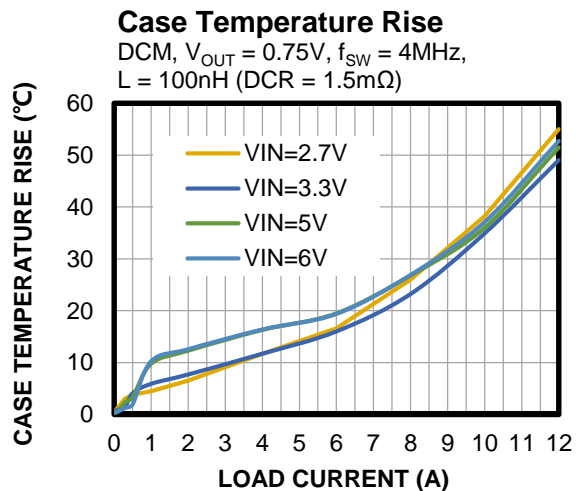
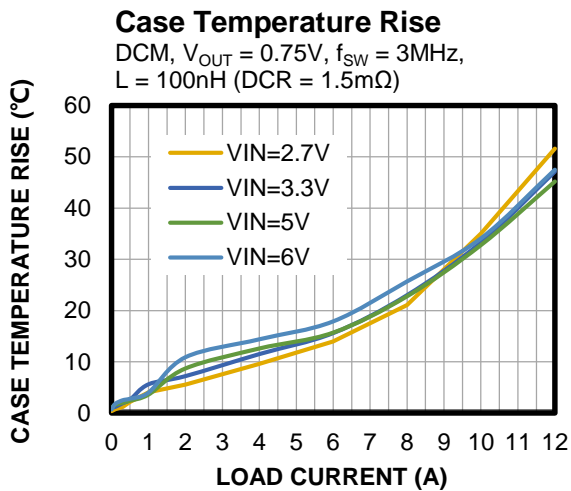
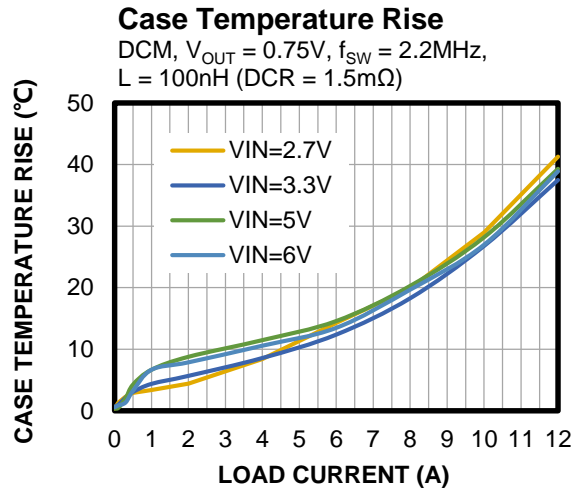
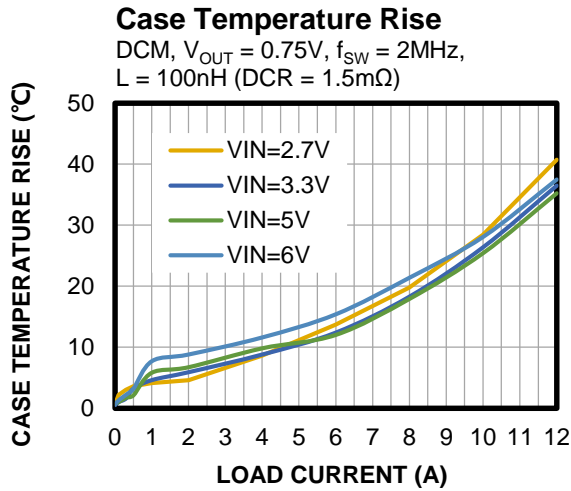

TYPICAL PERFORMANCE CHARACTERISTICS (continued)

$V_{IN} = 6V$, $V_{OUT} = 1.1V$, $L = 100nH$, $C_{OUT} = 4 \times 47\mu F$, $f_{SW} = 4MHz$, $I_{OUT} = 12A$, $T_A = 25^\circ C$, unless otherwise noted.

CISPR25 Class 5 Peak Conducted Emissions

150kHz to 108MHz

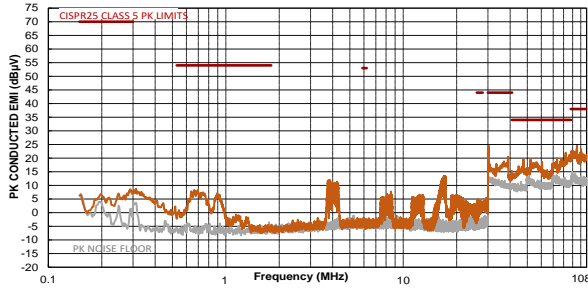

CISPR25 Class 5 Average Conducted Emissions

150kHz to 108MHz

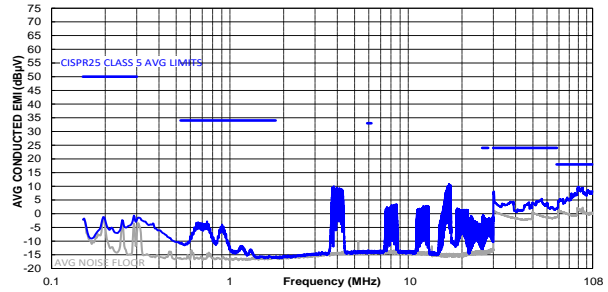

CISPR25 Class 5 Peak Radiated Emissions

150kHz to 30MHz

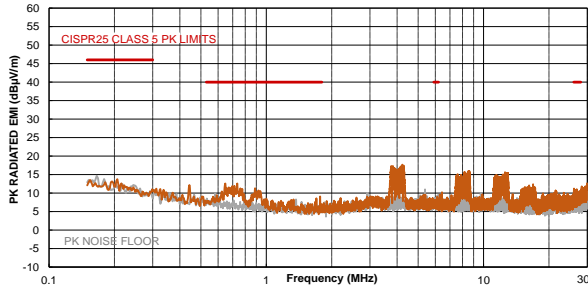

CISPR25 Class 5 Average Radiated Emissions

150kHz to 30MHz

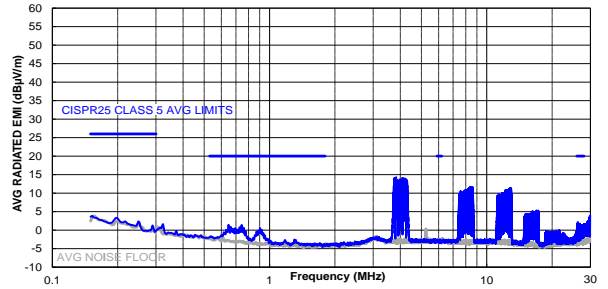

CISPR25 Class 5 Peak Radiated Emissions

Horizontal, 30MHz to 1GHz

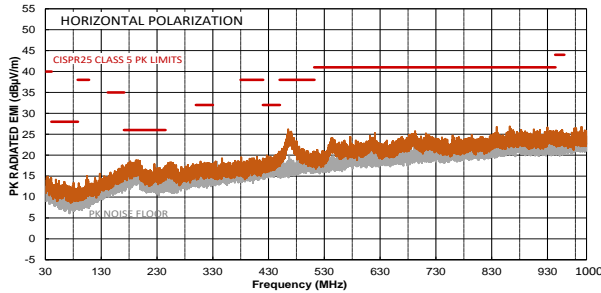

CISPR25 Class 5 Average Radiated Emissions

Horizontal, 30MHz to 1GHz

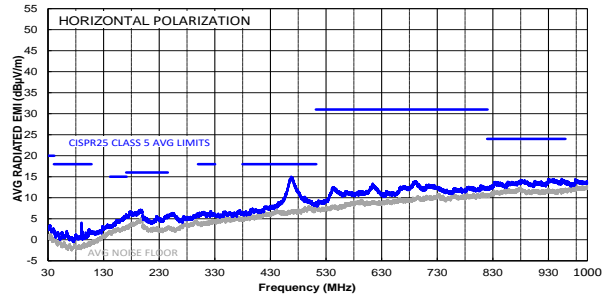

CISPR25 Class 5 Peak Radiated Emissions

Vertical, 30MHz to 1GHz

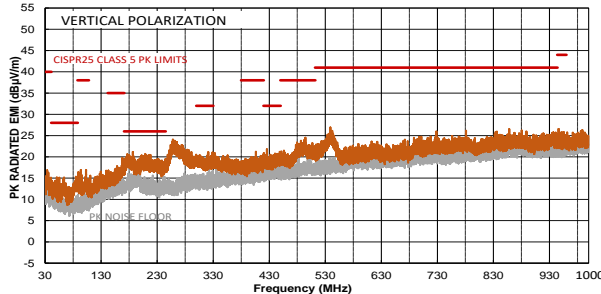

CISPR25 Class 5 Average Radiated Emissions

Vertical, 30MHz to 1GHz

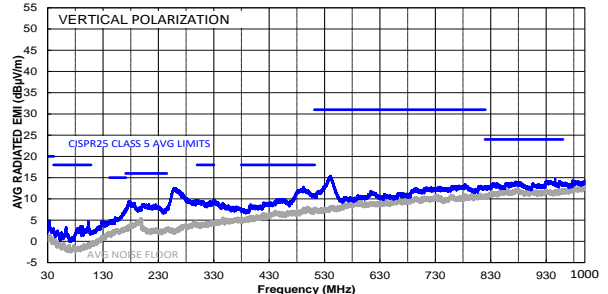

TYPICAL PERFORMANCE CHARACTERISTICS (continued)
 $V_{IN} = 5V$, $V_{OUT} = 0.75V$, $L = 100nH$, $C_{OUT} = 4 \times 47\mu F$, $f_{SW} = 3MHz$, DCM, $T_A = 25^\circ C$, unless otherwise noted.

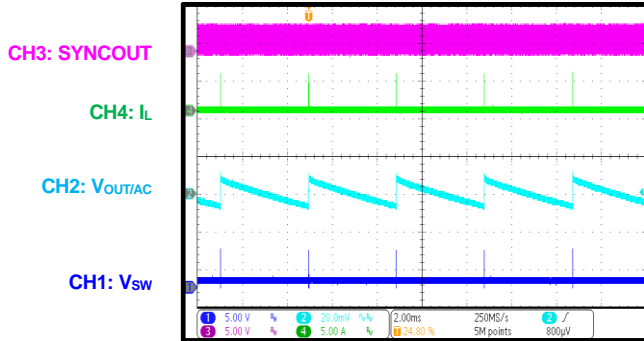
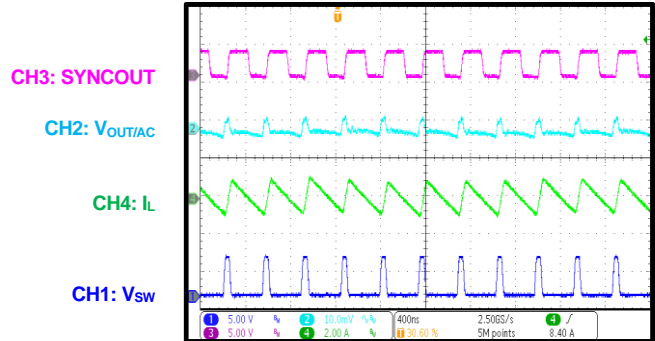
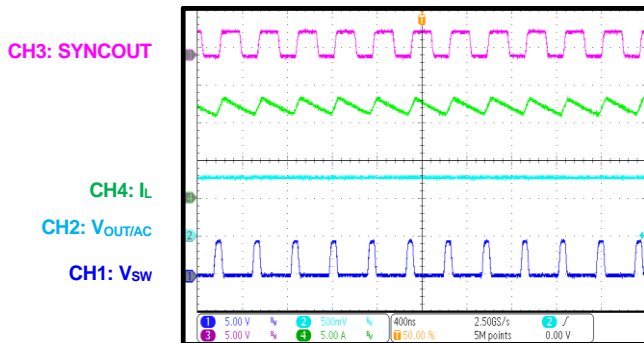
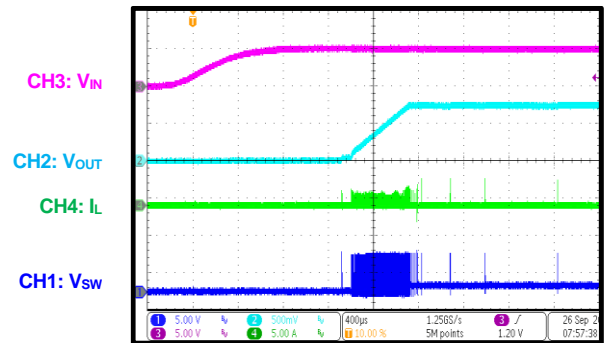
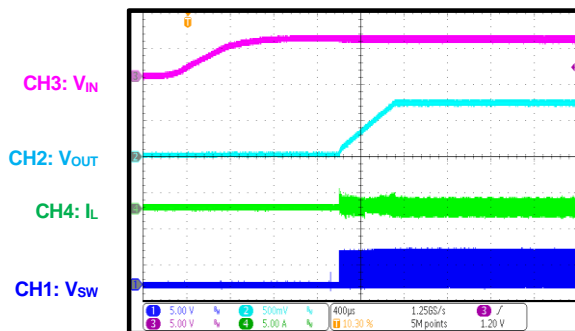
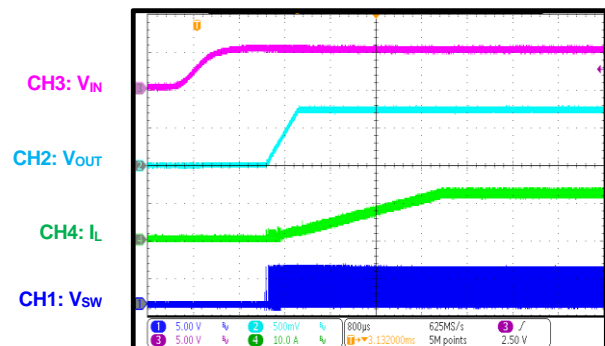
Steady State
 $I_{OUT} = 0A$, DCM

Steady State
 $I_{OUT} = 0A$, FCCM

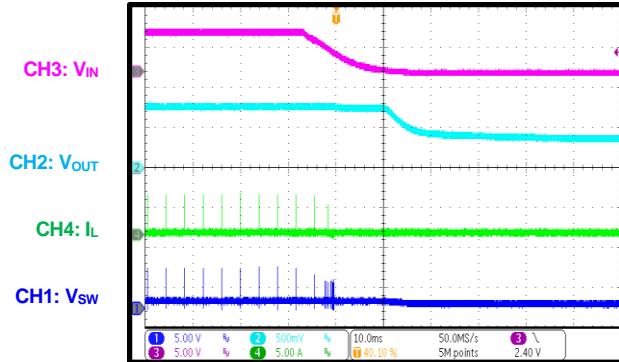
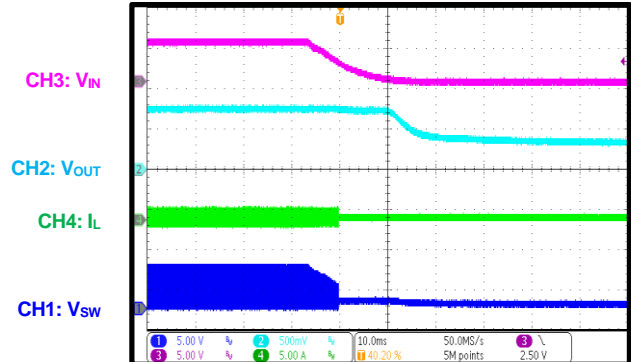
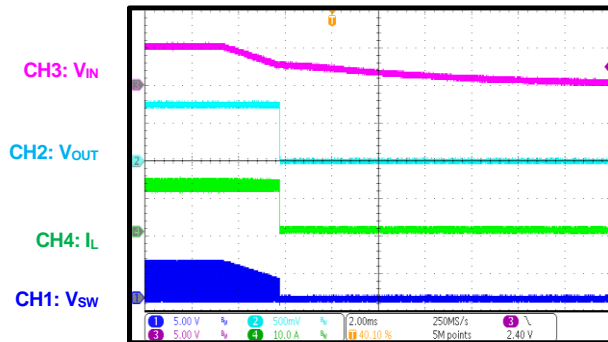
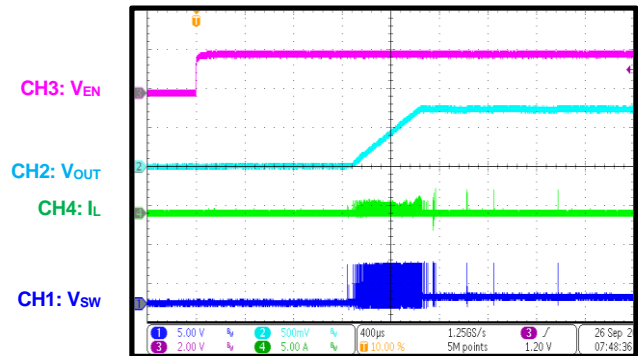
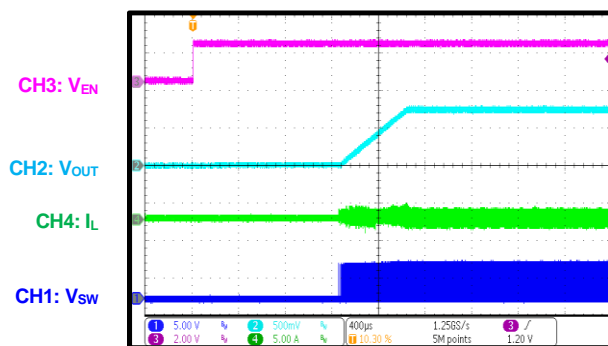
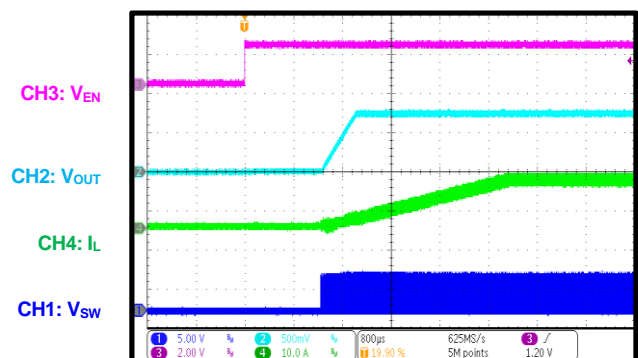
Steady State
 $I_{OUT} = 12A$

Start-Up through VIN
 $I_{OUT} = 0A$, DCM

Start-Up through VIN
 $I_{OUT} = 0A$, FCCM

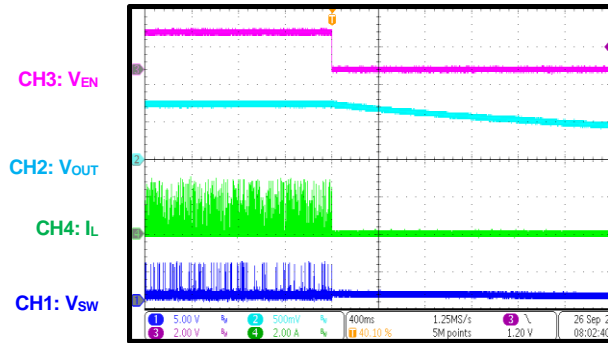
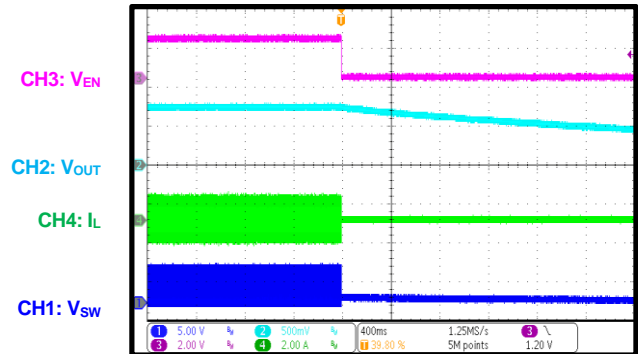
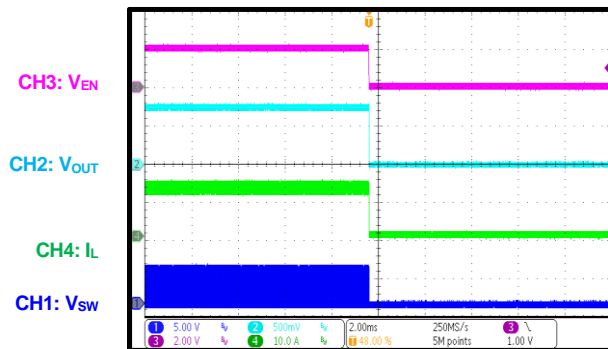
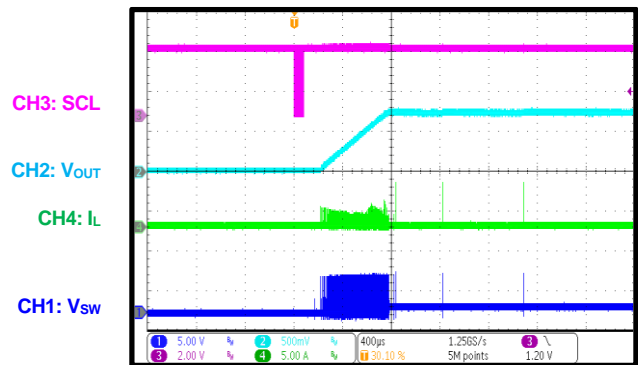
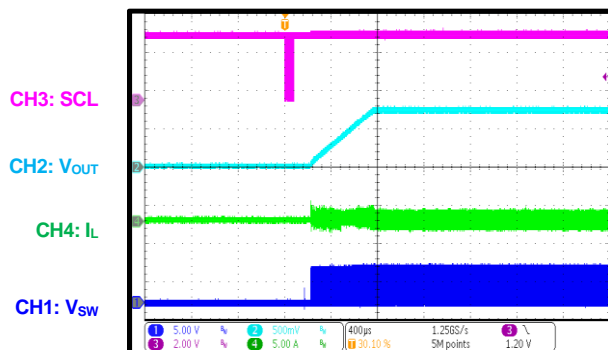
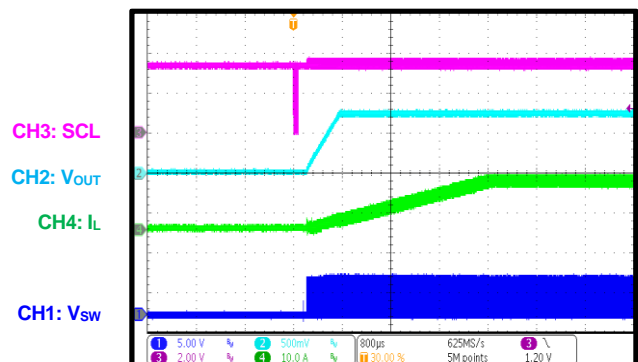
Start-Up through VIN
 $I_{OUT} = 12A$

TYPICAL PERFORMANCE CHARACTERISTICS (continued)
 $V_{IN} = 5V$, $V_{OUT} = 0.75V$, $L = 100nH$, $C_{OUT} = 4 \times 47\mu F$, $f_{SW} = 3MHz$, DCM, $T_A = 25^\circ C$, unless otherwise noted.

Shutdown through VIN
 $I_{OUT} = 0A$, DCM

Shutdown through VIN
 $I_{OUT} = 0A$, FCCM

Shutdown through VIN
 $I_{OUT} = 12A$

Start-Up through EN
 $I_{OUT} = 0A$, DCM

Start-Up through EN
 $I_{OUT} = 0A$, FCCM

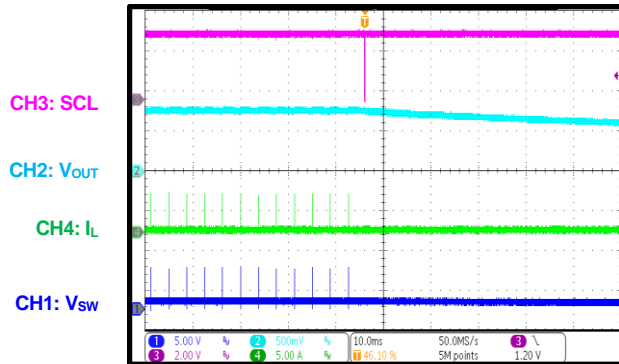
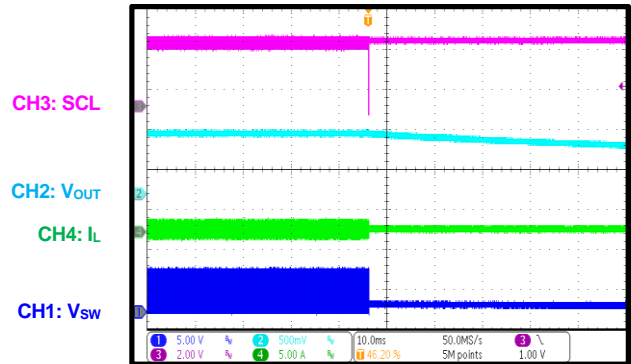
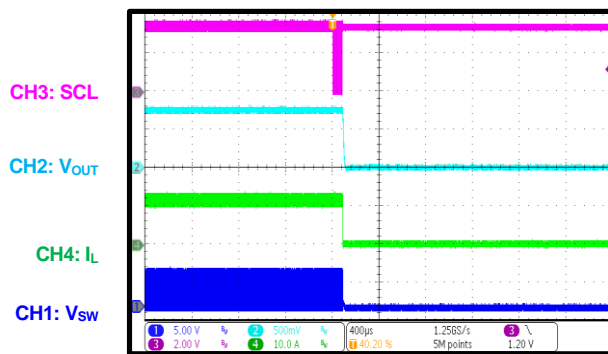
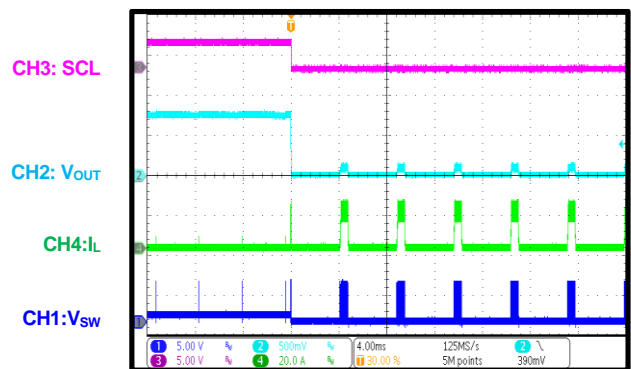
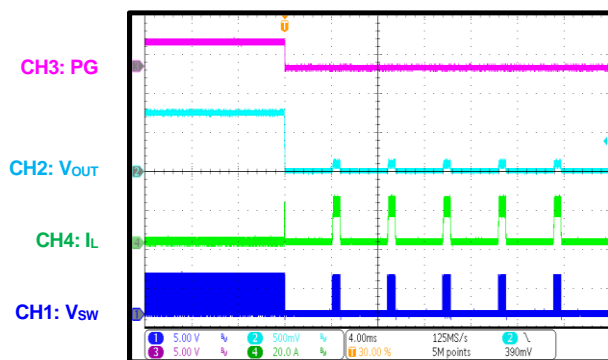
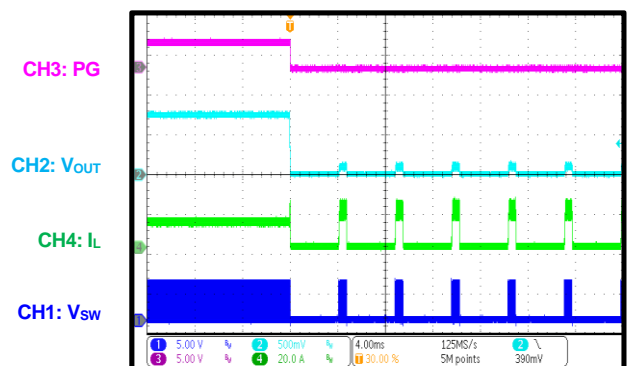
Start-Up through EN
 $I_{OUT} = 12A$

TYPICAL PERFORMANCE CHARACTERISTICS (continued)

$V_{IN} = 5V$, $V_{OUT} = 0.75V$, $L = 100nH$, $C_{OUT} = 4 \times 47\mu F$, $f_{SW} = 3MHz$, DCM, $T_A = 25^\circ C$, unless otherwise noted.

Shutdown through EN
 $I_{OUT} = 0A$, DCM

Shutdown through EN
 $I_{OUT} = 0A$, FCCM

Shutdown through EN
 $I_{OUT} = 12A$

Start-Up via the Digital Interface
 $I_{OUT} = 0A$, DCM

Start-Up via the Digital Interface
 $I_{OUT} = 0A$, FCCM

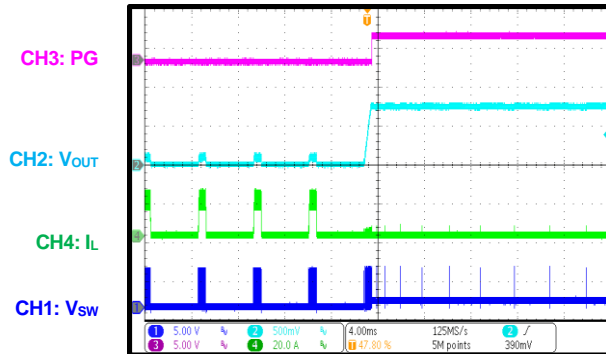
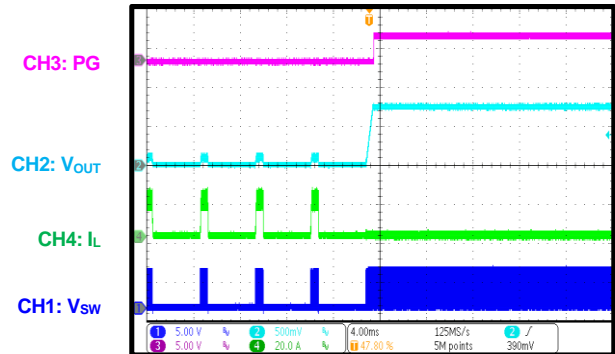
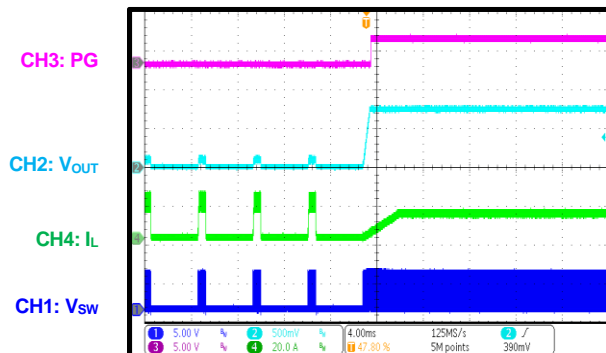
Start-Up via the Digital Interface
 $I_{OUT} = 12A$

TYPICAL PERFORMANCE CHARACTERISTICS (continued)
 $V_{IN} = 5V$, $V_{OUT} = 0.75V$, $L = 100nH$, $C_{OUT} = 4 \times 47\mu F$, $f_{SW} = 3MHz$, DCM, $T_A = 25^\circ C$, unless otherwise noted.

Shutdown via the Digital Interface
 $I_{OUT} = 0A$, DCM

Shutdown via the Digital Interface
 $I_{OUT} = 0A$, FCCM

Shutdown via the Digital Interface
 $I_{OUT} = 12A$

SCP Entry
 $I_{OUT} = 0A$, DCM

SCP Entry
 $I_{OUT} = 0A$, FCCM

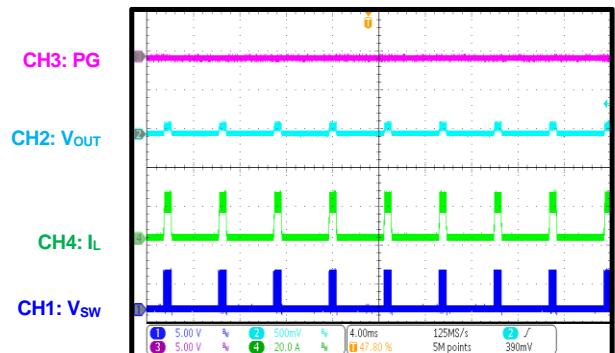
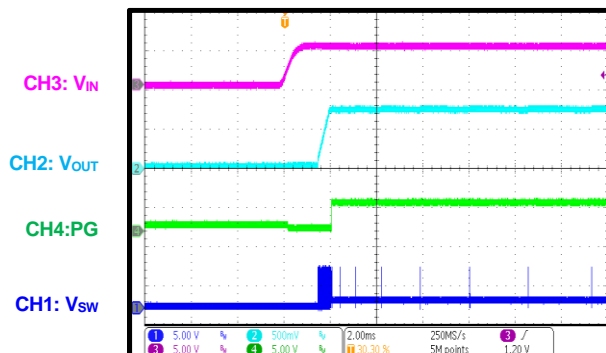
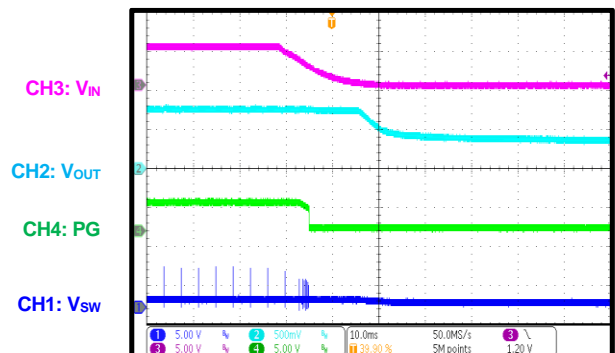
SCP Entry
 $I_{OUT} = 12A$

TYPICAL PERFORMANCE CHARACTERISTICS (continued)

$V_{IN} = 5V$, $V_{OUT} = 0.75V$, $L = 100nH$, $C_{OUT} = 4 \times 47\mu F$, $f_{SW} = 3MHz$, DCM, $T_A = 25^\circ C$, unless otherwise noted.

SCP Recovery
 $I_{OUT} = 0A$, DCM

SCP Recovery
 $I_{OUT} = 0A$, FCCM

SCP Recovery
 $I_{OUT} = 12A$

SCP Steady State

DCM

PG during Start-Up through VIN
 $I_{OUT} = 0A$, DCM

PG during Shutdown through VIN
 $I_{OUT} = 0A$, DCM

TYPICAL PERFORMANCE CHARACTERISTICS *(continued)*

$V_{IN} = 5V$, $V_{OUT} = 0.75V$, $L = 100nH$, $C_{OUT} = 4 \times 47\mu F$, $f_{SW} = 3MHz$, DCM, $T_A = 25^\circ C$, unless otherwise noted.

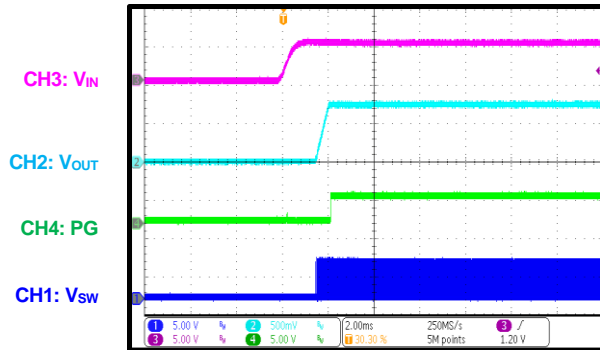
PG during Start-Up through VIN
 $I_{OUT} = 12A$



PG during Shutdown through VIN
 $I_{OUT} = 12A$

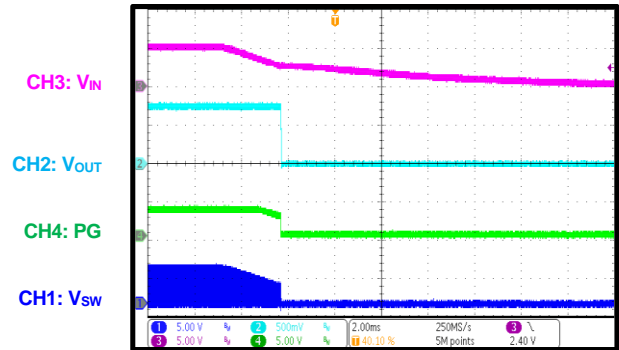

PG during Start-Up through EN
 $I_{OUT} = 0A$, DCM

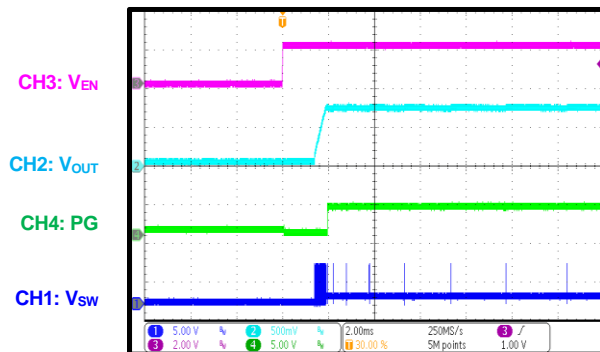

PG during Shutdown through EN
 $I_{OUT} = 0A$, DCM

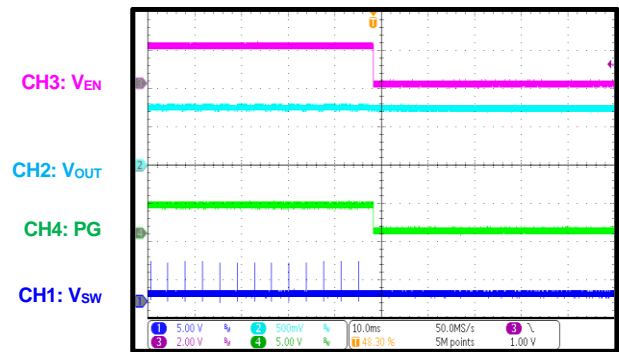

PG during Start-Up through EN
 $I_{OUT} = 12A$

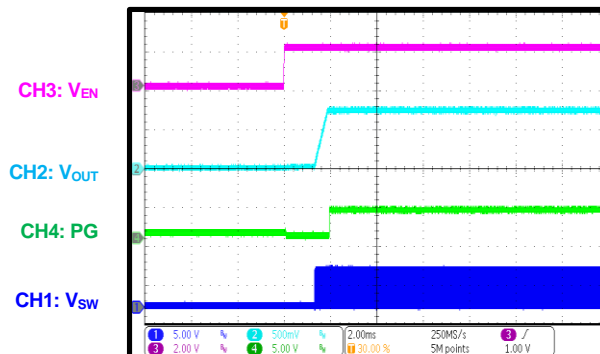

PG during Shutdown through EN
 $I_{OUT} = 12A$

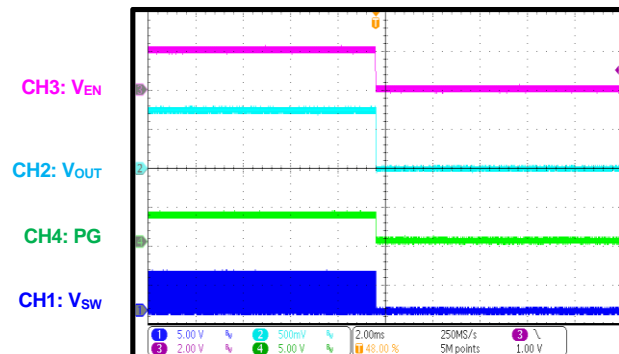

TYPICAL PERFORMANCE CHARACTERISTICS *(continued)*

$V_{IN} = 5V$, $V_{OUT} = 0.75V$, $L = 100nH$, $C_{OUT} = 4 \times 47\mu F$, $f_{SW} = 3MHz$, DCM, $T_A = 25^\circ C$, unless otherwise noted.

Load Transient Response

$I_{OUT} = 0A$ to $12A$, $1.6A/\mu s$

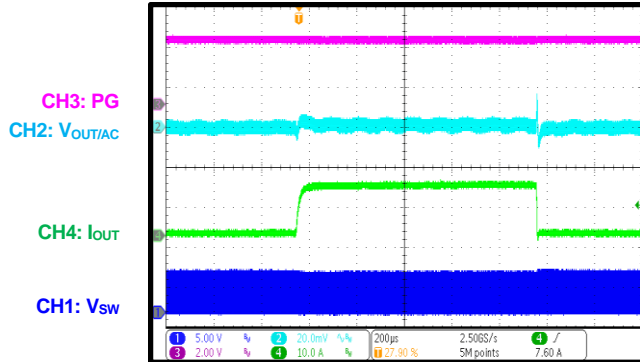

Load Transient Response

$I_{OUT} = 6A$ to $12A$, $1.6A/\mu s$

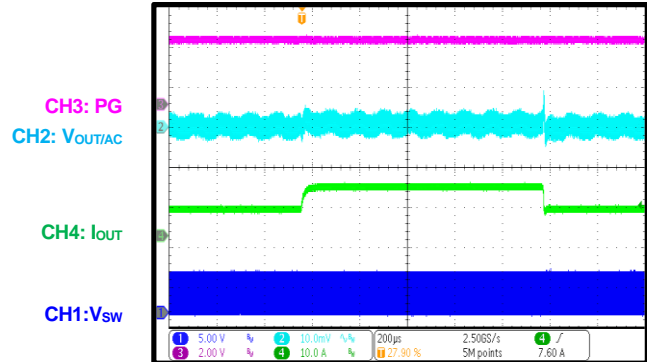

FUNCTIONAL BLOCK DIAGRAM

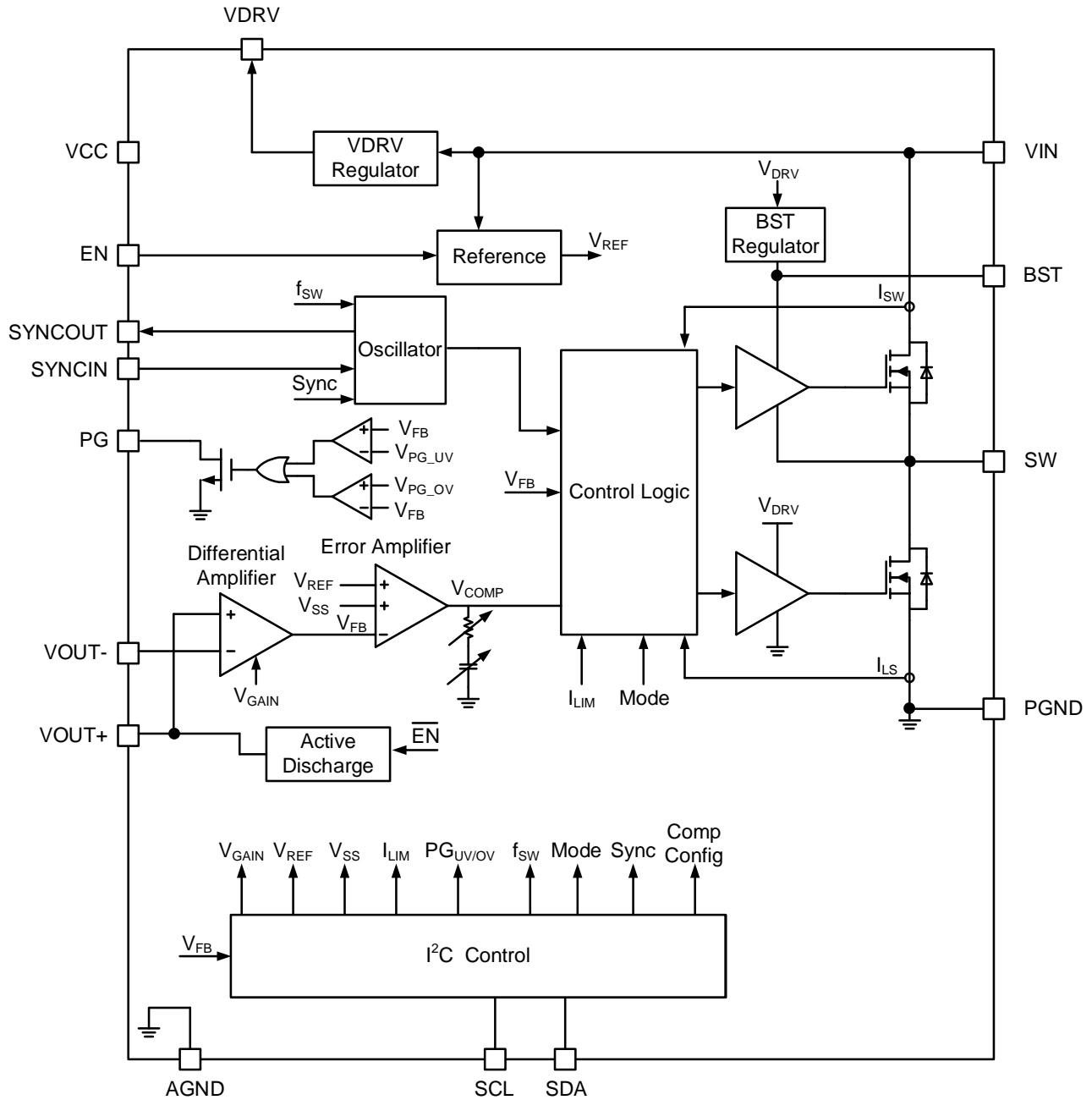

Figure 2: Functional Block Diagram

OPERATION

The MPQ2286 is a high-efficiency, high-frequency, synchronous buck regulator with integrated internal high-side and low side-power MOSFETs (HS-FET and LS-FET, respectively). The device provides 12A of highly efficient output current (I_{OUT}) with fixed-frequency, zero-delay PWM (ZDP™) control.

The device features a configurable 2MHz to 4MHz switching frequency (f_{SW}), soft start, soft stop, and precision current limit. It also features a digital interface with packet error checking (PEC) and integrated multi-page one-time programmable (OTP) memory, which allows for a high degree of configurability.

Zero-Delay PWM (ZDP™) Control

Automotive applications generally require fixed-frequency operation to reduce EMI concerns, but traditional fixed control topologies have major limitations. Voltage mode control is difficult to compensate in automotive environments, while peak current mode struggles to keep up with stringent modern system-on-chip (SoC) transient requirements with excessive output capacitance. With these requirements in mind, the MPQ2286 implements fixed-frequency, zero-delay PWM (ZDP™) control.

ZDP™ control combines current information with hysteretic-style output voltage control in a clocked system. This provides a near optimal transient response while maintaining a high phase margin across a wide variety of operating conditions and external component values. In addition, it maintains superior EMI performance. The improved transient response decreases output capacitance requirements, which lowers system cost. Trailing edge modulation facilitates a narrow on time for high conversion ratio applications.

At the beginning of the pulse-width modulation (PWM) cycle, the HS-FET turns off and the LS-FET turns on immediately until the control signal reaches the COMP voltage. The HS-FET remains off for at least 80ns at the beginning of the cycle.

Light-Load Operation

Under light-load conditions, the MPQ2286 can work in two different operation modes by setting the mode via the digital interface. The available

modes are forced continuous conduction mode (FCCM) and discontinuous conduction mode (DCM).

If configured for FCCM, the MPQ2286 works with a fixed frequency across the no-load to full-load range. The advantages of FCCM are the constant frequency and lower output voltage ripple at light loads.

With DCM is enabled, the MPQ2286 initiates non-synchronous operation when the inductor current reaches 0A. As the load is further reduced, the minimum peak inductor current is prevented from going below a fixed peak current value (see Figure 3). When this load condition is reached, f_{SW} starts to drop.

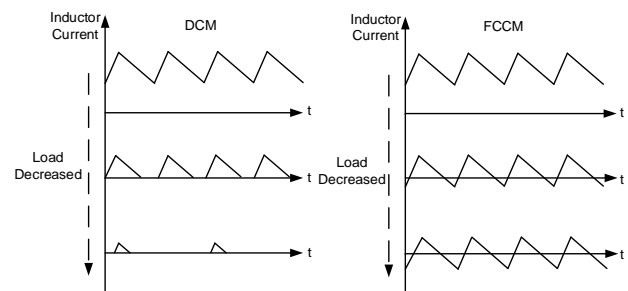

Figure 3: DCM and FCCM

Internal Regulator VDRV and VCC

The internal 3.3V VDRV regulator powers the gate driver and BST supply. This regulator uses V_{IN} as its input and operates across the full input voltage (V_{IN}) range. When V_{IN} exceeds 3.3V, VDRV is in full regulation. When V_{IN} is below 3.3V, the VDRV output degrades. Connect a 4.7 μ F capacitor from VDRV to PGND, and placed as close to the VDRV pin as possible, to decouple the supply.

Connect the VDRV supply to the VCC pin with a 2.2 Ω resistor and decouple the VCC pin with a 2.2 μ F capacitor connected to AGND to provide the power supply to the rest of the MPQ2286.

Dynamic Voltage Scaling

The output voltage (V_{OUT}) can be adjusted via the digital interface during normal operation. When the voltage changes, the slope is determined by the digital interface's VOUT_SLEW register.

During the rising transition, the device maintains the previous mode. During the falling transition, the device automatically switches to FCCM.

Bootstrap Charging

The bootstrap capacitor is charged and regulated to about 3.3V by the dedicated internal bootstrap regulator. When the voltage between the BST and SW nodes is below its regulation value, a transistor connected from VDRV to BST turns on to charge the bootstrap capacitor.

When the HS-FET is on, BST exceeds VDRV, so the bootstrap capacitor cannot be charged. Under higher duty cycle conditions, the time available for bootstrap charging is shorter, so the bootstrap capacitor may not be sufficiently charged. In this scenario, the bootstrap refresh circuit turns off the HS-FET and turns on the LS-FET to ensure that the bootstrap capacitor is correctly charged.

Enable (EN) Control

EN is a digital control pin that turns the regulator on and off. Forcing the EN pin above the EN threshold turns on the device. The device turns off when the EN pin is driven below 1.1V.

SYNCIN

f_{SW} can be synchronized to the rising edge of an external clock signal applied at SYNCIN. The high amplitude of the SYNC clock should exceed 1.8V and have a low amplitude below 0.4V to drive the internal logic. The recommended external SYNC frequency is set to $\pm 15\%$ for the range between 2MHz and 4MHz.

The MPQ2286 operates in FCCM with a fixed frequency when there is a SYNC clock, regardless of I_{OUT} . A pulse longer than 200ns is recommended. Connect SYNCIN to GND through a resistor if it is not used.

SYNCOUT

The MPQ2286 can output the internal clock with a 0° or 180° phase shift. With this function, two devices can operate at the same frequency but 180° out of phase to reduce the total input current ripple. This allows a lower-value input bypass capacitor to be used.

Soft Start

The soft-start function is implemented to prevent V_{OUT} from overshooting during start-up. When the MPQ2286 starts up, the internal circuitry generates a soft-start voltage that ramps up from 0V. The soft-start period lasts until the voltage on the soft-start capacitor exceeds the reference voltage (V_{REF}). At this point, the error amplifier uses V_{REF} as the reference. There are four available soft-start slew rates, which can be configured via the OTP.

Soft Stop

Four shutdown slew rates are available to set the soft-stop time, which can be enabled via the OTP. The soft stop function is implemented to discharge V_{OUT} . When the MPQ2286 starts to turn off, V_{REF} ramps down and V_{OUT} follows. This causes charge to transfer from the output to the input. During the soft-stop period, the MPQ2286 operates in FCCM, even if the MPQ2286 is set to operate in DCM. The soft-stop slew rates can be configured via the OTP.

Minimum On Time and Minimum Off Time

When the device triggers the minimum on time (26ns), the MPQ2286's control loop automatically skips some pulses. The part does not decrease the frequency once the minimum off time (80ns) is triggered. This means that for applications with a low V_{IN} and a high V_{OUT} , V_{OUT} drops once the device reaches the minimum off time.

Output Discharge

An optional 120Ω discharge MOSFET is available, which can be configured via the OTP. When enabled, the discharge MOSFET turns on after the part is disabled. This MOSFET continues to operate as long as $V_{IN} > 2.4V$.

Pre-Biased Start-Up

If V_{OUT} exceeds 0V at start-up, both the HS-FET and LS-FET remain off until the soft-start ramp reaches V_{OUT} .

Power Good (PG) Indicator

The power good (PG) indicator is an open-drain output that indicates whether V_{OUT} is within the power good thresholds. The pin asserts (pulls low) if the power is outside of the PG thresholds, the output is off, or if soft start/shutdown occurs. PG can also be configured to indicate thermal

warning or digital interface communication failures via the OTP.

Over-Current Protection (OCP)

The MPQ2286 implements cycle-by-cycle over-current protection (OCP) to limit I_{OUT} . The peak and valley current limits ensure protection regardless of the duty cycle.

When the inductor current (I_L) reaches the high-side peak current limit while the HS-FET is on, the HS-FET is forced off immediately to prevent the current from rising further. If the clock is received before I_L reaches current limit, the HS-FET also turns off due to the clock.

When the LS-FET is on, the next clock's rising edge is held until I_L drops below the low-side valley current limit. Then I_L can drop to a sufficiently low value when the HS-FET turns on again. This current limit scheme prevents current runaway if an overload or short-circuit event occurs.

Short-Circuit Protection (SCP) and Under-Voltage Protection (UVP)

If V_{OUT} is below 75% of the configured output voltage, short-circuit protection and output under-voltage protection (UVP) is triggered. The output shuts off for the hiccup time, and restarts with a full soft-start period. It is possible to enable or disable output under-voltage protection via the OTP. If enabled, the output discharge function operates during the hiccup time.

Output Over-Voltage Protection (OVP)

If an output exceeds the output over-voltage protection (OVP) threshold, that output shuts off for the hiccup time, and then the normal soft-start process begins again. Enable or disable output OVP via the OTP. If enabled, the output discharge function operates during the hiccup time.

Input Over-Voltage Protection (OVP)

If V_{IN} exceeds 6.7V, input OVP is triggered. The MPQ2286 starts operating once the V_{IN} drops below the input OVP threshold (OVP rising threshold - OVP hysteresis).

Thermal Warning (TW)

If the die temperature exceeds the thermal warning threshold, the thermal warning register asserts. The power good function can be

configured to indicate whether thermal warning has occurred via the PG_MAPPING register.

Thermal Shutdown (TSD)

If the die temperature exceeds the thermal shutdown threshold, the MPQ2286 disables switching and the PG pin asserts.

Multi-Page One-Time Programmable (OTP) Memory

The MPQ2286 features two user pages of OTP memory to store settings permanently.

For long-term reliability, a differential OTP cell is used instead of a single-ended cell. Data is stored on two floating gate avalanche injection metal oxide semiconductors (FAMOS), and output comparators are used for differential reading.

Only the code MPQ2286-0000 has OTP memory that can be written to twice; all other codes have OTP memory that can be written to once, or not at all. The OTP memory can be written to via the dedicated STORE_USER_ALL (15h) command.

Cyclic Redundancy Check (CRC)

The OTP memory is protected by a cyclic redundancy check (CRC). If the calculated CRC value does not match the recorded value during the power on process, the device does not start up.

Remote Output Voltage Sensing

The remote output voltage sensing function is implemented to compensate for the voltage drop in the copper between the MPQ2286 and the load caused by the large output current and the resistance in the transmission line. Figure 4 shows the remote output voltage sensing circuit, connect the VOUT+ and VOUT- pins close to the load with a Kelvin connection to accurately sense the output voltage.

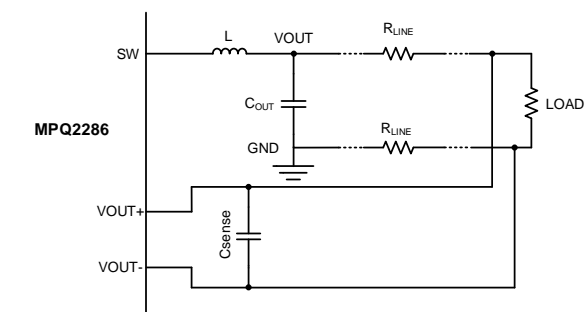

Figure 4: Remote Output Voltage Sensing Circuit

DIGITAL INTERFACE

Digital Serial Interface Description

The digital interface is an open-standard, power-management protocol that defines a means of communication with power conversion and other devices. The digital interface is a two-wire, bidirectional serial interface, consisting of a serial data line (SDA) and a serial clock line (SCL). The lines are externally pulled to a bus voltage when they are idle. Connecting to the line, a master device generates the SCL signal and device address, and arranges the communication sequence.

The MPQ2286 works as a slave-only device, which supports fast-mode plus (1Mbps) bidirectional data transfer, adding flexibility to the power supply solution. The output voltage, transition slew rate, and other converter parameters can be instantaneously controlled via the digital interface.

Data Validity

One clock pulse is generated for each data bit transferred. The data on the SDA line must be stable during the high period of the clock. The high or low state of the SDA line can only change when the clock signal on the SCL line is low (see Figure 5).

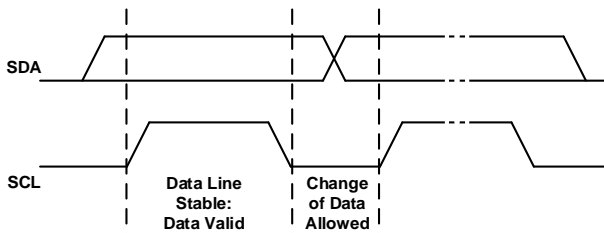

Figure 5: Bit Transfer on the Digital Interface

Start and Stop Commands

The start and stop commands are signaled by the master device, which signifies the beginning and the end of the digital interface transfer. The start (S) command is defined as the SDA signal transitioning from high to low while the SCL line is high. The stop (P) command is defined as the SDA signal transitioning from low to high while the SCL is high (see Figure 6).

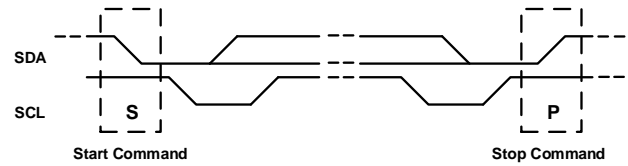

Figure 6: Start and Stop Command

Start and stop commands are always generated by the master. The bus is considered busy after the start command. The bus is considered free again after a certain time after the stop command. The bus stays busy if a repeated start (Sr) command is generated instead of a stop command. The start and repeated start commands are functionally identical.

Transfer Data

Every byte put on the SDA line must be 8 bits long. Each byte must be followed by an acknowledge (ACK) bit. The acknowledge-related clock pulse is generated by the master. The transmitter releases the SDA line (high) during the acknowledge clock pulse. The receiver must pull down the SDA line during the acknowledge clock pulse, so that it remains stable low during the high period of the clock pulse.

Figure 7 shows the data transfer format. After the start command, a slave address is sent. This address is 7 bits long followed by an 8th data direction bit (R/W). A 0 indicates a transmission (write), and a 1 indicates a request for data (read). Data transfer is always terminated by a stop command, which is generated by the master. However, if a master still wishes to communicate on the bus, it can generate a repeated start command and address another slave without first generating a stop command.

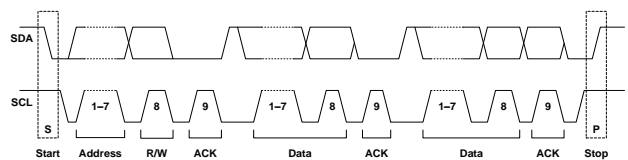

Figure 7: A Complete Data Transfer

STATE MACHINE DESCRIPTION

The state machine describes the different states of operation. There are six states in the device: POWER OFF, RESTORE_OTP, START-UP,

NORMAL, STORE_USER, and RESTORE_USER (see Figure 10).

Each state is described in greater detail below.

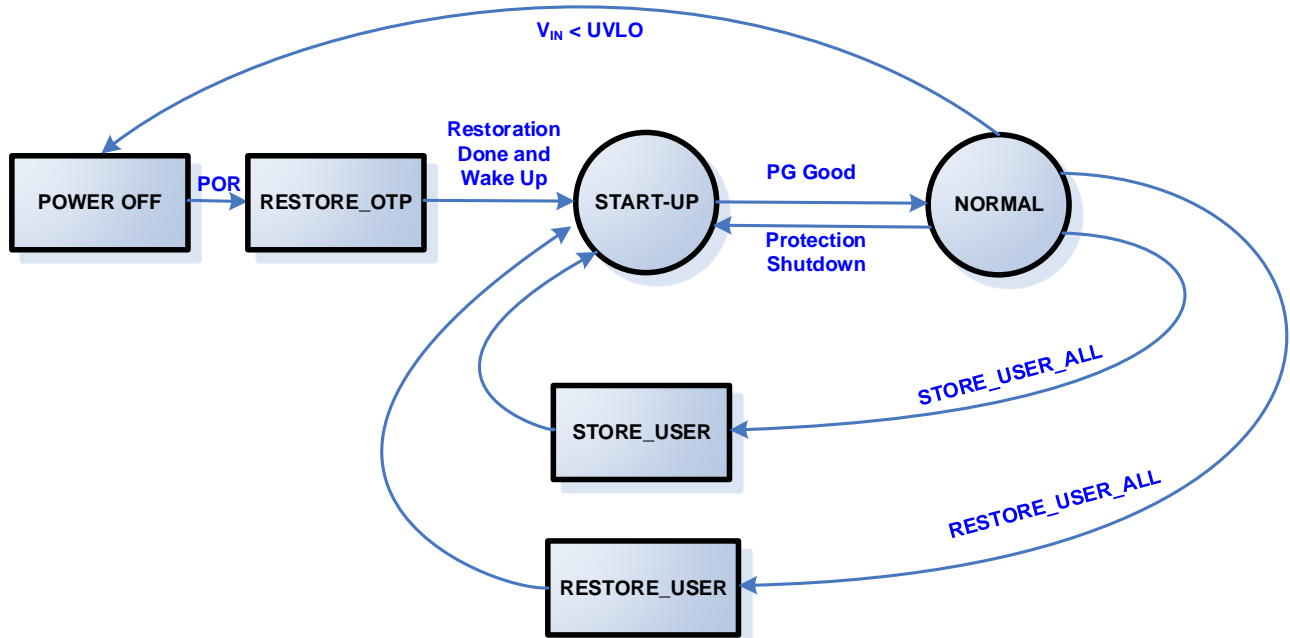

Figure 10: System State Machine

Power Off State (POWER OFF)

The MPQ2286 is in the power off state as long the power on reset (POR) is not released.

Restore the OTP State (RESTORE_OTP)

When V_{IN} exceeds its rising UVLO threshold, POR is released. The MPQ2286 restores the registers from the embedded OTP content data. Once restoration is complete, the MPQ2286 automatically enters the start-up state.

Start-Up State (START-UP)

Once restoring the OTP is complete and the wake-up signal is enabled, the device enters the start-up state. All the other supplies are enabled and the output starts to ramp up in the start-up state.

Normal State (NORMAL)

The MPQ2286 enters the normal state as soon as the output regulator voltage is power good. The normal state is the standard operating state for the MPQ2286, during which the output regulator is up and running.

Store User State (STORE_USER)

The store user state writes the present data from the registers to the internal OTP content. Then the MPQ2286 transitions to the start-up state and restarts. Only writing to the STORE_USER_ALL register from the normal state can force the device to enter the store user state. See the STORE_USER_ALL (15h) section on page 46 for more details.

Restore User State (RESTORE_USER)

The restore user state copies the entire contents of the OTP values to the matching locations in the registers. The values in the registers are overwritten by the value retrieved from the OTP. Any items in the OTP that do not have matching locations in the operating memory are ignored. Then the MPQ2286 transitions to the start-up state and restarts. Only writing to RESTORE_USER_ALL register from the normal state can force the device to enter the restore user state. See the RESTORE_USER_ALL (16h) section on page 46 for more details.

REGISTER MAP

Command Code	Command Name	Type	Bytes	OTP	Page 0
01h	OPERATION	R/W	1	Yes	✓
03h	CLEAR_FAULTS	W	0	No	✓
10h	WRITE_PROTECT	R/W	1	No	✓
15h	STORE_USER_ALL	W	0	No	✓
16h	RESTORE_USER_ALL	W	0	No	✓
19h	CAPABILITY	R	1	No	✓
20h	VOUT_MODE	R	1	No	✓
21h	VOUT_COMMAND	R/W	1	Yes	✓
24h	VOUT_MAX	R/W	1	Yes	✓
29h ⁽¹¹⁾	VOUT_SCALE	R/W	1	Yes	✓
2Bh	VOUT_MIN	R/W	1	Yes	✓
60h	TON_DELAY	R/W	1	Yes	✓
64h	TOFF_DELAY	R/W	1	Yes	✓
78h	STATUS_BYTE	R/W	1	No	✓
79h	STATUS_WORD	R/W	2	No	✓
7Ah	STATUS_VOUT	R/W	1	No	✓
7Bh	STATUS_IOUT	R/W	1	No	✓
7Ch	STATUS_INPUT	R/W	1	No	✓
7Dh	STATUS_TEMPERATURE	R/W	1	No	✓
7Eh	STATUS_CML	R/W	1	No	✓
9Bh	MFR_REVISION	R	1	No	✓
C4h	SECURE_LOCKOUT	R/W	1	No	✓
C5h	HICCUP_TIMER	R/W	1	Yes	✓
C6h	VOUT_STARTUP_SLEW	R/W	1	Yes	✓
C7h	VOUT_SHUTDOWN_SLEW	R/W	1	Yes	✓
C8h	VOUT_SLEW	R/W	1	Yes	✓
C9h	OUTPUT_DISCHARGE	R/W	1	Yes	✓
CAh	FREQUENCY_DITHER	R/W	1	Yes	✓
CBh	FREQUENCY_SET	R/W	1	Yes	✓
CCh	COMPENSATION_CONFIG	R/W	2	Yes	✓
CEh	PROTECTION_CONFIG	R/W	1	Yes	✓
CDh	PG_MAPPING	R/W	1	Yes	✓
CFh	PG_DELAY	R/W	1	Yes	✓
D0h	PG_CONFIG	R/W	1	Yes	✓
D1h	LIGHT_LOAD	R/W	1	Yes	✓
D2h	ILIM_SCALE	R/W	1	Yes	✓
D3h	ADDRESS	R/W	1	Yes	✓
D4h	CONFIGURATION_CODE	R	1	Yes	✓
D5h	MEMORY_CRC	R	2	Yes	✓
D6h	LATEST_PEC	R	1	No	✓
D8h	MFR_OTP_MEM_STATUS	R	1	No	✓

REGISTER MAP (continued)

Command Code	Command Name	Type	Bytes	OTP	Page 0
DBh	ADVANCED_CONFIG	W	1	No	✓
DCh	SUMMING_BLOCK_CONFIG	R/W	1	Yes	✓
DDh	MIN_ON_CONFIG	R/W	1	Yes	✓

Note:

11) This register value cannot be modified while the device is operating. Disable the output before modifying this register.

REGISTER MAP (PAGE 0)

OPERATION (01h)

Format: Unsigned binary

The OPERATION command on Page 0 configures the converter output's on/off state, in conjunction with input from the EN pin.

Bits	Access	Bit Name	Default	Description
7	R/W	OPERATION	1'b1	1'b1: Output on (if enabled high) 1'b0: Output off
6:0	R	RESERVED	N/A	Unused. Writes are ignored and always read as 0.

CLEAR_FAULTS (03h)

The CLEAR_FAULTS command on Page 0 clears any fault bit in all status registers: STATUS_BYTE (78h), STATUS_WORD (79h), STATUS_VOUT (7Ah), STATUS_INPUT (7Ch), STATUS_TEMPERATURE (7Dh), and STATUS_CML (7Eh).

This command is write-only. There is no data byte for this command.

WRITE_PROTECT (10h)

Format: Unsigned binary

The WRITE_PROTECT command on Page 0 controls writing to the converter. The intent of this command is to provide protection against accident changes. It is not intended to provide protection against deliberate changes to the converter's configuration or operation. All the supported commands may have their parameters read, regardless of the WRITE_PROTECT settings.

Bits	Access	Bit Name	Default	Description
7:0	R/W	WRITE_PROTECT	8'b00000000	8'b10000000: Disable all writes except to the WRITE_PROTECT command 8'b01000000: Disable all writes except to the WRITE_PROTECT, OPERATION, and PAGE commands 8'b00100000: Disable all writes except to the WRITE_PROTECT, OPERATION, PAGE, and VOUT_COMMAND commands 8'b00000000: Enable writes to all commands Others: Invalid commands

STORE_USER_ALL (15h)

The STORE_USER_ALL command on Page 0 instructs the MPQ2286 to copy the contents of the operating memory to the matching locations in the OTP, except for the internal trim registers. This process begins when the MPQ2286 receives a STORE_USER_ALL command from the digital interface.

This command is write-only. There is no data byte for this command.

RESTORE_USER_ALL (16h)

The RESTORE_USER_ALL command on Page 0 instructs the MPQ2286 to copy the contents from the OTP and overwrite the matching locations in the operating memory, except for the trim registers. Any items in the OTP that do not have matching locations in the operating memory are ignored.

The RESTORE_USER_ALL command can be used while the MPQ2286 is operating. However, the MPQ2286 may be unresponsive during this operation with unpredictable, undesirable, or even catastrophic results.

This command is write-only. There is no data byte for this command.

CAPABILITY (19h)
Format: Unsigned binary

The CAPABILITY command on Page 0 provides 1 byte to return key digital interface features that the MPQ2286 can support.

Bits	Access	Bit Name	Default	Description
7	R	PACKET_ERR_CHECKING	1'b1	1'b1: Packet error checking (PEC) is supported Others: Invalid commands
6:5	R	MAX_BUS_SPEED	2'b10	2'b10: The maximum supported bus speed is 1MHz Others: Invalid commands
4	R	SMBALERT#	1'b0	1'b0: The device does not have a SMBALERT# pin and does not support the SMBus Alert Response protocol Others: Invalid commands
3	R	NUMERIC_FORMAT	1'b0	1'b0: Numeric data is in Linear11, ULinear16, Slinear16, or direct format Others: Invalid commands
2	R	AVSBUS_SUPPORT	1'b0	1'b0: AVSBus is not supported Others: Invalid commands
1:0	R	RESERVED	N/A	Reserved.

VOUT_MODE (20h)
Format: Unsigned binary

The VOUT_MODE command on Page 0 commands and reads the output voltage mode. The 3MSB determine the data format (only direct format is supported by the MPQ2286).

Bits	Access	Bit Name	Default	Description
7:0	R	VOUT_MODE	8'b010000 00	8'b01000000: Direct mode. The coefficients are m = 160, R = 0, and b = -33 Others: Invalid commands

VOUT_COMMAND (21h)
Format: Unsigned binary

The VOUT_COMMAND command on Page 0 sets V_{OUT} .

Bits	Access	Bit Name	Default	Description
7:0	R/W	VOUT_CMD	8'b011111 11	V_{OUT} can be calculated with the following equation: $V_{OUT} = (VOUT_CMD \times 6.25mV + 206.25mV) \times VOUT_SL$ If $VOUT_SL = 1$, V_{OUT} can be set between 0.20625V and 1.8V. If $VOUT_SL = 2$, V_{OUT} can be set between 0.4125V and 3.6V.

VOUT_MAX (24h)

Format: Unsigned binary

The VOUT_MAX command on Page 0 sets an upper limit on the V_{OUT} that the converter can command, regardless of any other commands or combinations. The intent of this command is to provide a safeguard against a user accidentally setting V_{OUT} to a possibly destructive level, rather than to be the primary output over-voltage protection (OVP).

Bits	Access	Bit Name	Default	Description
7:0	R/W	VOUT_MAX	8'b111111 11	<p>Sets the maximum V_{OUT}, which can be calculated with the following equation:</p> $V_{OUTMAX} = (VOUT_MAX \times 6.25mV + 206.25mV) \times VOUT_SL$ <p>If VOUT_SL = 1, V_{OUT} can be set between 0.20625V and 1.8V. If VOUT_SL = 2, V_{OUT} can be set between 0.4125V and 3.6V.</p> <p>Attempting to write a higher value to VOUT_COMMAND causes VOUT_COMMAND to be set to VOUT_MAX, and asserts a VOUT_MAX_MIN warning.</p>

VOUT_SCALE_LOOP (29h)

Format: Unsigned binary

The VOUT_SCALE_LOOP command on Page 0 sets the V_{OUT} scale.

Bits	Access	Bit Name	Default	Description
7:1	R/W	RESERVED	N/A	Reserved.
0	R/W	VOUT_SC_L	1'b0	<p>Sets the V_{OUT} scale. Direct mode. The coefficients are m = 1, R = 0, and b = -1.</p> <p>1'b0: VOUT_SL = 1 1'b1: VOUT_SL = 2</p>

VOUT_MIN (2Bh)

Format: Unsigned binary

The VOUT_MIN command on Page 0 sets a lower limit on the V_{OUT} that the converter can command, regardless of any other commands or combinations. The intent of this command is to provide a safeguard against a user accidentally setting V_{OUT} to a possibly destructive level, rather than to be the primary output under-voltage protection (UVP).

Bits	Access	Bit Name	Default	Description
7:0	R/W	VOUT_MIN	8'b000000 00	<p>Sets the minimum V_{OUT}, which can be calculated with the following equation:</p> $V_{OUTMIN} = (VOUT_MIN \times 6.25mV + 206.25mV) \times VOUT_SL$ <p>If VOUT_SL = 1, V_{OUT} can be set between 0.20625V and 1.8V. If VOUT_SL = 2, V_{OUT} can be set between 0.4125V and 3.6V.</p> <p>Attempting to write a lower value to VOUT_COMMAND causes VOUT_COMMAND to be set to VOUT_MIN, and asserts a VOUT_MAX_MIN warning.</p>

TON_DELAY (60h)

Format: Unsigned binary

The TON_DELAY command on Page 0 sets the start-up delay time.

Bits	Access	Bit Name	Default	Description
7:5	R/W	RESERVED	N/A	Reserved.

4:0	R/W	TON_DELAY	5'b00000	<p>Sets the start-up delay time, calculated with the following equation:</p> $\text{Start-Up Delay} = \text{TON_DELAY} \times 0.25\text{ms}$ <p>The delay can range between 0ms and 7.75ms.</p>
-----	-----	-----------	----------	--

TOFF_DELAY (64h)

Format: Unsigned binary

The TOFF_DELAY command on Page 0 sets the shutdown delay time.

Bits	Access	Bit Name	Default	Description
7:5	R/W	RESERVED	N/A	Reserved.
4:0	R/W	TOFF_DELAY	5'b00000	<p>Sets the shutdown delay time, calculated with the following equation:</p> $\text{Shutdown Delay} = \text{TOFF_DELAY} \times 0.25\text{ms}$ <p>The delay can range between 0ms and 7.75ms.</p>

STATUS_BYTE (78h)

Format: Unsigned binary

The STATUS_BYTE command on Page 0 returns the value of a number of flags indicating the state of the MPQ2286. Send a CLEAR_FAULTS (03h) command to clear the fault flag bits after the fault is removed. See the CLEAR_FAULTS (03h) section on page 46 for more details.

Bits	Access	Bit Name	Default	Description
7	R/W	BUSY	1'b0	1'b0: No busy fault 1'b1: A fault was declared because the device was busy and unable to respond
6	R/W	OFF	1'b0	1'b0: The device is on 1'b1: The device is off
5	R/W	VOUT_OV_FAULT	1'b0	1'b0: No output over-voltage (OV) fault has occurred 1'b1: An output OV fault has occurred
4	R/W	IOUT_OC_FAULT	1'b0	1'b0: No output over-current (OC) fault has occurred 1'b1: An output OC fault has occurred
3	R/W	RESERVED	N/A	Reserved.
2	R/W	TEMPERATURE	1'b0	1'b0: No temperature fault or warning has occurred 1'b1: A temperature fault or warning has occurred
1	R/W	CML	1'b0	1'b0: No communications, memory, or logic fault has occurred 1'b1: A communications, memory, or logic fault has occurred
0	R/W	FAULT_OTHER	1'b0	1'b0: No other fault has occurred 1'b1: A fault not covered by bits[7:1] of this command has occurred

STATUS_WORD (79h)

Format: Unsigned binary

The STATUS_WORD command on Page 0 returns 2 bytes of information with a summary of the device's fault/warning conditions. The higher byte gives more detailed information of the fault conditions. The lower byte is shared with register STATUS_BYTE (78h). Send a CLEAR_FAULTS (03h) command to clear the fault flag bits after the fault is removed. See the CLEAR_FAULTS (03h) section on page 46 for more details.

Bits	Access	Bit Name	Default	Description
15	R/W	VOUT_FAULT	1'b0	1'b0: No output voltage fault has occurred 1'b1: An output voltage fault has occurred
14	R/W	IOUT_FAULT	1'b0	1'b0: No output current fault has occurred 1'b1: An output current fault has occurred
13	R/W	VIN_FAULT	1'b0	1'b0: No input voltage fault has occurred 1'b1: An input voltage fault has occurred
12	R/W	MANUFAC_FAULT	1'b0	1'b0: No manufacturer specific fault has occurred 1'b1: A manufacturer specific fault has occurred
11	R/W	PGOOD	1'b0	1'b0: Power good is high 1'b1: Power good is low
10:8	R/W	RESERVED	N/A	Reserved.
Low Byte	R/W	STATUS_BYTE	8'b00000000	The same as STATUS BYTE (78h).

STATUS_VOUT (7Ah)

Format: Unsigned binary

The STATUS_VOUT command on Page 0 returns detailed fault information. Clear the fault flag bit by writing 1 to the fault bit after this fault has been removed.

Bits	Access	Bit Name	Default	Description
7	R/W	VOUT_OV_FAULT	1'b0	1'b0: No output over-voltage (OV) fault has occurred 1'b1: An output OV fault has occurred
6:5	R/W	RESERVED	N/A	Reserved.
4	R/W	VOUT_UV_FAULT	1'b0	1'b0: No output under-voltage (UV) fault has occurred 1'b1: An output UV fault has occurred
3	R/W	VOUT_MAX_MIN_WARN	1'b0	1'b0: No attempt to set V _{OUT} beyond V _{OUT_MIN} or V _{OUT_MAX} has occurred 1'b1: An attempt to set V _{OUT} beyond V _{OUT_MIN} or V _{OUT_MAX} has occurred
2:0	R/W	RESERVED	N/A	Reserved.

STATUS_IOUT (7Bh)

Format: Unsigned binary

The STATUS_IOUT command on Page 0 returns detailed fault information. Clear the fault flag bit by writing 1 to the fault bit after this fault has been removed.

Bits	Access	Bit Name	Default	Description
7	R/W	IOUT_OC_FAULT	1'b0	1'b0: No output over-current (OC) fault has occurred 1'b1: An output OC fault has occurred
6:0	R/W	RESERVED	N/A	Reserved1.

STATUS_INPUT (7Ch)
Format: Unsigned binary

The STATUS_INPUT command on Page 0 returns detailed fault information. Clear the fault flag bit by writing 1 to the fault bit after this fault has been removed.

Bits	Access	Bit Name	Default	Description
7	R/W	VIN_OV_FAULT	1'b0	1'b0: No input over-voltage (OV) fault has occurred 1'b1: An input OV fault has occurred
6:0	R/W	RESERVED	N/A	Reserved.

STATUS_TEMPERATURE (7Dh)
Format: Unsigned binary

The STATUS_TEMPERATURE command on Page 0 returns detailed fault information. Clear the fault flag bit by writing 1 to the fault bit after this fault has been removed.

Bits	Access	Bit Name	Default	Description
7	R/W	TEMP_OT_FAULT	1'b0	1'b0: No over-temperature (OT) fault has occurred 1'b1: An over temperature fault has occurred
6	R/W	TEMP_OT_WARNING	1'b0	1'b0: No OT warning has occurred 1'b1: An OT warning has occurred
5:0	R/W	RESERVED	N/A	Reserved.

STATUS_CML (7Eh)
Format: Unsigned binary

The STATUS_CML command on Page 0 returns detailed fault information. Clear the fault flag bit by writing 1 to the fault bit after this fault has been removed.

Bits	Access	Bit Name	Default	Description
7	R/W	INVALID_CMD	1'b0	1'b0: No invalid or unsupported command has been received 1'b1: An invalid or unsupported command has been received
6	R/W	INVALID_DATA	1'b0	1'b0: No invalid or unsupported data has been received 1'b1: Invalid or unsupported data has been received
5	R/W	PEC_ERROR	1'b0	1'b0: No PEC failure has occurred 1'b1: A PEC failure has occurred
4	R/W	MEMORY_FAULT	1'b0	1'b0: No CRC failure has occurred 1'b1: A CRC failure has occurred
3:0	R/W	RESERVED	N/A	Reserved.

SECURE_LOCKOUT (C4h)
Format: Unsigned binary

The SECURE_LOCKOUT command on Page 0 locks out access to most registers.

Bits	Access	Bit Name	Default	Description
7:0	R/W	SECURE_LOCKOUT	8'b00000000	Write 01011010 to lockout write access to most registers. Registers listed as No under the "Lockout?" column on the Register Map section starting on page 44 can still be written. These bits can only be cleared by setting all enables to low. Other commands are invalid.

HICCUP_TIMER (C5h)
Format: Unsigned binary

The HICCUP_TIMER command on Page 0 sets the hiccup timer.

Bits	Access	Bit Name	Default	Description
7:2	R/W	RESERVED	N/A	Reserved.
1:0	R/W	HICCUP_TIMER	2'b01	2'b00: 2ms 2'b01: 4ms 2'b10: 6ms 2'b11: 8ms

VOUT_STARTUP_SLEW (C6h)
Format: Unsigned binary

The VOUT_STARTUP_SLEW command on Page 0 sets the start-up slew rate.

Bits	Access	Bit Name	Default	Description
7:2	R/W	RESERVED	N/A	Reserved.
1:0	R/W	VOUT_STARTUP_SLEW	2'b00	2'b00: VOUT_SL x 1.25mV/μs 2'b01: VOUT_SL x 2.5mV/μs 2'b10: VOUT_SL x 5mV/μs 2'b11: VOUT_SL x 10mV/μs

VOUT_SHUTDOWN_SLEW (C7h)
Format: Unsigned binary

The VOUT_SHUTDOWN_SLEW command on Page 0 sets the shutdown slew rate.

Bits	Access	Bit Name	Default	Description
7:2	R/W	RESERVED	N/A	Reserved.
1:0	R/W	VOUT_SHUTDOWN_SLEW	2'b00	2'b00: VOUT_SL x 1.25mv/us 2'b01: VOUT_SL x 2.5mv/us 2'b10: VOUT_SL x 5mv/us 2'b11: VOUT_SL x 10mv/us

VOUT_SLEW (C8h)
Format: Unsigned binary

 The VOUT_SLEW command on Page 0 sets the V_{OUT} slew rate.

Bits	Access	Bit Name	Default	Description
7:2	R/W	RESERVED	N/A	Reserved.
1:0	R/W	VOUT_SLEW	2'b00	2'b00: VOUT_SL x 2.5mv/us 2'b01: VOUT_SL x 5mv/us 2'b10: VOUT_SL x 10mv/us 2'b11: VOUT_SL x 20mv/us

OUTPUT_DISCHARGE (C9h)
Format: Unsigned binary

The OUTPUT_DISCHARGE command on Page 0 configures the discharge mode during shutdown.

Bits	Access	Bit Name	Default	Description
7:2	R/W	RESERVED	N/A	Reserved.
1	R/W	SS_EN	1'b0	1'b0: Soft stop disabled 1'b1: Soft stop enabled

0	R/W	DISCHARGE_EN	1'b0	1'b0: 100Ω output discharge disabled 1'b1: 100Ω output discharge enabled
---	-----	--------------	------	---

FREQUENCY_DITHER (CAh)

Format: Unsigned binary

The FREQUENCY_DITHER command on Page 0 enables frequency spread spectrum (FSS).

Bits	Access	Bit Name	Default	Description
7:1	R/W	RESERVED	N/A	Reserved.
0	R/W	FREQUENCY_DITHER	1'b1	Enables FSS. 1'b0: Disabled 1'b1: Enabled

FREQUENCY_SET (CBh)

Format: Unsigned binary

The FREQUENCY_SET command on Page 0 sets the SYNC output phase and the switching frequency.

Bits	Access	Bit Name	Default	Description
7:3	R/W	RESERVED	N/A	Reserved.
2	R/W	SYNCO_PHASE	1'b1	Sets the SYNC output phase. 1'b0: 180° 1'b1: 0°
1:0	R/W	FREQUENCY_SET	2'b00	Sets the switching frequency. 2'b00: 2MHz 2'b01: 2.2MHz 2'b10: 3MHz 2'b11: 4MHz

COMPENSATION_CONFIG (CCh)

Format: Unsigned binary

The COMPENSATION_CONFIG command on Page 0 configures the compensation network parameters.

Bits	Access	Bit Name	Default	Description
15:10	R/W	RESERVED	N/A	Reserved.
9:7	R/W	CCOMP	3'b000	Sets C _{COMP} . 3'b000: 30pF 3'b001: 10pF 3'b010: 20pF 3'b011: 0pF 3'b100: 50pF 3'b110: 40pF Others: Invalid commands
6:4	R/W	CPOLE	3'b000	Sets C _{POLE} , calculated with the following equation: $C_{POLE} = (\text{COMPENSATION_CONFIG} \times 0.1\text{pF} + 20\text{pF})$

3:0	R/W	RCOMP	4'b0000	Sets R _{COMP} . 4'b0000: 20Ω 4'b0001: 25kΩ 4'b0010: 50kΩ 4'b0011: 75kΩ 4'b0100: 100kΩ 4'b0101: 125kΩ 4'b0110: 150kΩ 4'b0111: 175kΩ 4'b1001: 225kΩ 4'b1010: 250kΩ 4'b1011: 275kΩ 4'b1100: 300kΩ 4'b1101: 325kΩ 4'b1110: 350kΩ 4'b1111: 400kΩ Others: Invalid commands
-----	-----	-------	---------	---

PROTECTION_CONFIG (CEh)

Format: Unsigned binary

The PROTECTION_CONFIG command on Page 0 enables certain functions.

Bits	Access	Bit Name	Default	Description
7:5	R/W	RESERVED	N/A	Reserved.
4	R/W	VIN_OVP_EN	1'b1	1'b0: Disable input over-voltage protection (OVP) 1'b1: Enable input OVP
3:2	R/W	OCP_CONFIG	2'b11	Configures whether over-current protection (OCP) causes a hiccup. 2'b00: OCP does not directly cause a hiccup 2'b01: 32 consecutive cycles of an OC condition causes a hiccup 2'b10: 64 consecutive cycles of an OC condition causes a hiccup 2'b11: 128 consecutive cycles of an OC condition causes a hiccup
1	R/W	VOUT_OVP_EN	1'b0	1'b0: Disable output OVP 1'b1: Enable output OVP
0	R/W	VOUT_UVP_EN	1'b0	1'b0: Disable output under-voltage protection (UVP) 1'b1: Enable output UVP

PG_MAPPING (CDh)

Format: Unsigned binary

The PG_MAPPING command on Page 0 configures whether PG pulls low for certain digital interface and thermal warning errors.

Bits	Access	Bit Name	Default	Description
7:3	R/W	RESERVED	N/A	Reserved.
2	R/W	PM_CML_PG_MAPPING	1'b0	Maps PG for digital interface communication failures. 1'b0: A digital interface communication failure causes PG to go low and register assertion 1'b1: A digital interface communication failure causes register assertion only

1	R/W	PM_CRC_PGMAPPING	1'b0	Maps PG for a digital interface CRC failure. 1'b0: A digital interface CRC failure causes PG to go low and register assertion 1'b1: A digital interface CRC failure cause register assertion only
0	R/W	THERMAL_WARN_PGMAPPING	1'b0	Maps PG for a thermal warning. 1'b0: A thermal warning causes PG to go low and register assertion 1'b1: A thermal warning causes register assertion only

PG_DELAY (CFh)

Format: Unsigned binary

The PG_DELAY command on Page 0 sets the de-assertion delay for PG.

Bits	Access	Bit Name	Default	Description
7:2	R/W	RESERVED	N/A	Reserved.
1:0	R/W	PG_DELAY	2'b00	Sets the PG de-assertion delay. 2'b00: Immediate 2'b01: 2ms 2'b10: 5ms 2'b11: 10ms

PG_CONFIG (D0h)

Format: Unsigned binary

The PG_CONFIG command on Page 0 sets the PG threshold.

Bits	Access	Bit Name	Default	Description
7:1	R/W	RESERVED	N/A	Reserved.
0	R/W	PG_THRESHOLD	1'b1	Sets the PG threshold. 1'b0: $\pm 4\%$ of the set value 1'b1: $\pm 6\%$ of the set value

LIGHT_LOAD (D1h)

Format: Unsigned binary

The LIGHT_LOAD command on Page 0 sets the operation mode under light-load conditions.

Bits	Access	Bit Name	Default	Description
7:2	R/W	RESERVED	N/A	Reserved.
1	R/W	USM	1'b0	Sets the minimum frequency for ultrasonic mode. 1'b0: No minimum frequency 1'b1: 50kHz
0	R/W	FCCM	1'b0	Sets discontinuous conduction mode (DCM) or forced continuous conduction mode (FCCM). 1'b0: DCM is allowed 1'b1: FCCM

ILIM_SCALE (D2h)

Format: Unsigned binary

The ILIM_SCALE command on Page 0 sets the current limit scale. For the MPQ2286 at a 12A load level, the current limit scale should be set to 100%. Other options do not guarantee that the current limit parameters conform to the Electrical Characteristics section on page 5.

Bits	Access	Bit Name	Default	Description
7:2	R/W	RESERVED	N/A	Reserved.
1:0	R/W	ILIM_SCALE	2'b00	Sets the current limit scale. 2'b00: 50% 2'b01: 75% 2'b10: 100% Other: Invalid commands

ADDRESS (D3h)

Format: Unsigned binary

The ADDRESS command on Page 0 sets the address for digital interface communication.

Bits	Access	Bit Name	Default	Description
7	R/W	RESERVED	N/A	Reserved.
6:0	R/W	ADDRESS	7'b000001 1	Sets the 7-bit digital interface address.

CONFIG_CODE (D4h)

Format: Unsigned binary

The CONFIG_CODE command on Page 0 returns the configuration code.

Bits	Access	Bit Name	Default	Description
7:0	R	CONFIG_CODE	8'b000000 00	Returns the configuration code.

MEMORY_CRC (D5h)

Format: Unsigned binary

The MEMORY_CRC command on Page 0 returns the OTP data.

Bits	Access	Bit Name	Default	Description
15:0	R	MEMORY_CRC	16'b000000 000000000 00	Returns the CRC for the OTP data.

LATEST_PEC (D6h)

Format: Unsigned binary

The LATEST_PEC command on Page 0 returns the latest calculated packet error code from the previous write transition.

Bits	Access	Bit Name	Default	Description
7:0	R	LATEST_PEC	8'b000000 00	Stores the latest calculated packet error code from the previous write transition.

MFR_OTP_MEM_STATUS (D8h)
Format: Unsigned binary

The MFR_OTP_MEM_STATUS command on Page 0 indicates whether certain OTP-related errors have occurred.

Bits	Access	Bit Name	Default	Description
7:3	R	RESERVED	N/A	Reserved.
2	R	STRUP_OTP_CRC_ERR	1'b0	0: No start-up load OTP CRC error has occurred 1: A start-up load OTP CRC error has occurred
1	R	STRUP_OTP_IND_ERR	1'b0	0: No start-up load OTP indicator error has occurred 1: A start-up load OTP indicator error has occurred
0	R	STORE_OTP_ERR	1'b0	0: No store OTP failure has occurred 1: A store OTP failure has occurred

ADVANCED_CONFIG (DBh)
Format: Unsigned binary

The ADVANCED_CONFIG command on Page 0 can enable advanced configuration read and write. The advanced configurations include the DCh and DDh registers.

Bits	Access	Bit Name	Default	Description
7:0	R/W	ADVANCED	N/A	8'b11100001: Enable advanced configuration read and write Others: Disable advanced configuration read and write

SUMMING_BLOCK_CONFIG (DCh)
Format: Unsigned binary

The SUMMING_BLOCK_CONFIG command on Page 0 can sets loop performance parameters.

Bits	Access	Bit Name	Default	Description
7:6	R/W	RESERVED	N/A	Reserved.
5:3	R/W	CURRENT_SENSE_GAIN	3'b000	There are no units; this is a ratio compared to the nominal value of 1. 3'b000: 1 x ISENSE_GAIN_SCALE 3'b001: 0.75 x ISENSE_GAIN_SCALE 3'b010: 0.5 x ISENSE_GAIN_SCALE 3'b011: 0.25 x ISENSE_GAIN_SCALE 3'b100: 1.25 x ISENSE_GAIN_SCALE 3'b101: 1.5 x ISENSE_GAIN_SCALE 3'b110: 1.75 x ISENSE_GAIN_SCALE 3'b111: 2 x ISENSE_GAIN_SCALE
2:1	R/W	SLOPE_GM	2'b00	There are no units; this is a ratio compared to the nominal value of 1. 2'b00: 1 x SLOPE_GM_SCALE 2'b01: 0.5 x SLOPE_GM_SCALE 2'b10: 1.5 x SLOPE_GM_SCALE 2'b11: 2 x SLOPE_GM_SCALE
0	R/W	FB_GM	1'b0	1'b0: FB_GM divider = 1 1'b1: FB_GM divider = 2

MIN_ON_CONFIG (DDh)
Format: Unsigned binary

The MIN_ON_CONFIG command on Page 0 sets the minimum on-time specifications and loop performance.

Bits	Access	Bit Name	Default	Description
7	R/W	ADAPTIVE_MIN_ON_FCCM	1'b0	Enables the adaptive minimum on time during FCCM. 1'b0: Enabled 1'b1: Disabled
6	R/W	ADAPTIVE_MIN_ON_SS	1'b0	Enables the adaptive minimum on time during soft start. 1'b0: Enabled 1'b1: Disabled
5	R/W	ISENSE_GAIN_SCALE	1'b0	Set the scale for CURRENT_SENSE_GAIN. 1'b0: 1 1'b1: 2
4	R/W	SLOPE_GM_SCALE	1'b0	Set the scale for SLOPE_GM. 1'b0: 1 1'b1: 2
3	R/W	MIN_OFF	1'b0	Increases the 15ns minimum off time. 1'b0: Disable 1'b1: Enable
2:0	R/W	ADAPTIVE_MIN_ON	3'b000	Sets the minimum on time parameter. There are no units; this is a ratio compared to the nominal value of 1. The smaller the ratio, the greater the minimum on time. 3'b000: 1 3'b001: 0.8 3'b010: 0.6 3'b011: 0.4 3'b100: 1 3'b101: 1.2 3'b110: 1.4 3'b111: 1.6

APPLICATION INFORMATION

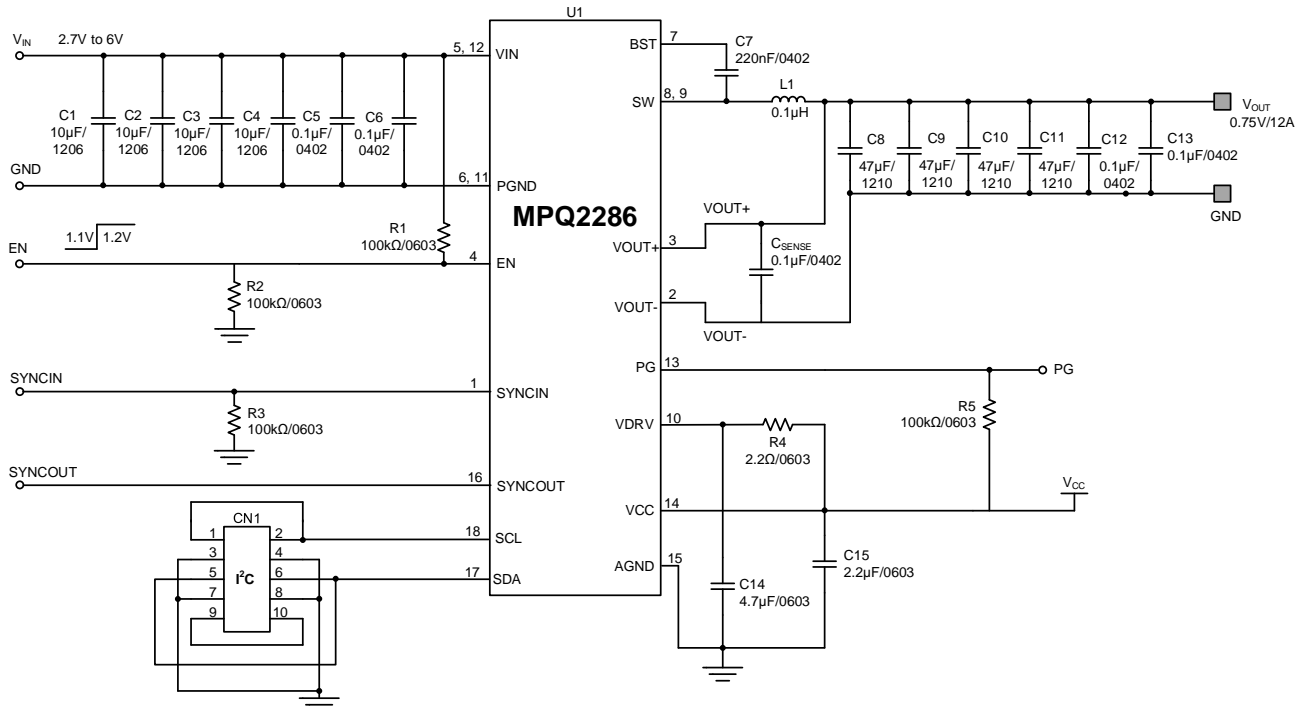

Figure 11: Typical Application Circuit ($V_{OUT} = 0.75V$, $f_{sw} = 3MHz$)

Table 1: Design Guide Index

Pin #	Pin Name	Component	Design Guide Index
1	SYNCIN	R3	External Sync Input (SYNCIN, Pin 1)
2	VOUT-	C _{SENSE}	Setting the Output Voltage (VOUT-, Pin 2; VOUT+, Pin 3)
3	VOUT+	C _{SENSE}	Setting the Output Voltage (VOUT-, Pin 2; VOUT+, Pin 3)
4	EN	R1, R2	Enable (EN, Pin 4)
5, 12	VIN	C1, C2, C3, C4, C5, C6	Selecting the Input Capacitor (VIN, Pins 5 and 12)
6, 11	PGND	-	GND Connection (PGND, Pin 6 and 11; AGND Pin 15)
15	AGND	-	GND Connection (PGND, Pin 6 and 11; AGND Pin 15)
7	BST	C7	Floating Driver and Bootstrap Charging (BST, Pin 7)
8, 9	SW	L1, C8, C9, C10, C11, C12, C13	Selecting the Inductor and Output Capacitor (SW, Pins 8 and 9)
10	VDRV	C14	Internal LDO Output (VDRV, Pin 10)
13	PG	R5	Power Good indicator (PG, Pin 13)
14	VCC	R4, C15	Supply Input for Internal Analog and Digital Circuits (VCC, Pin 14)
16	SYNCOUT	-	SYNC Output (SYNCOUT, Pin 16)
17	SDA	-	Digital Interface (SDA, Pin 17; SCL, Pin 18)
18	SCL	-	Digital Interface (SDA, Pin 17; SCL, Pin 18)

External Sync Input (SYNCIN, Pin 1)

When the external clock signal is connected to the SYNCIN pin, the switching frequency can be synchronized to the rising edge. The high amplitude of SYNC clock should exceed 1.8V and its low amplitude should be below 0.4V to drive the internal logic. The recommended external SYNC frequency is $\pm 15\%$ the set frequency when the range is between 2MHz and 4MHz.

Setting the Output Voltage (VOUT-, Pin 2; VOUT+, Pin 3)

The OTP registers VOUT_COMMAND and VOUT_SCALE_LOOP set V_{OUT}.

Write to VOUT_COMMAND (21h), bits[7:0] (VOUT_CMD), and VOUT_SCALE_LOOP (29h), bit[0] (VOUT_SC_L). V_{OUT} can be calculated with Equation (1):

$$V_{OUT} \text{ (mV)} = (V_{OUT_CMD} \times 6.25 + 206.25) \times V_{OUT_SL} \quad (1)$$

Set VOUT_SC_L to 0 when V_{OUT} is between 0.20625V and 1.8V. If V_{OUT} is between 1.8V and 3.6V, set VOUT_SC_L to 1. The output must be disabled via the digital interface when writing to VOUT_SC_L in register VOUT_SCALE_LOOP.

It is recommended to use another lower-value capacitor (e.g. 0.1 μ F) with a small package size (0603) to absorb high-frequency switching noise. Place the smaller capacitor as close to VOUT+ and VOUT- as possible.

Enable (EN, Pin 4)

EN is a digital control pin that turns the regulator on and off. When the EN pin voltage exceeds 0.65V, the VDRV supply turns on. In this scenario, digital interface communication operates normally, and the host can read/write to the MPQ2286's registers normally. When the EN pin's voltage exceeds 1.2V the MPQ2286 turns on.

Selecting the Input Capacitor (VIN, Pin 5 and 12)

The step-down converter has a discontinuous input current, and requires a capacitor to supply AC current to the converter while maintaining the DC input voltage. For the best performance, use low-ESR capacitors. Ceramic capacitors with X5R or X7R dielectrics are highly recommended because of their low ESR and small temperature coefficients.

It is recommended to use another lower-value capacitor (e.g. 0.1 μ F) with a small package size (0603) to absorb high-frequency switching noise. Place the smaller capacitor as close to VIN and GND as possible.

Since the input capacitor (C_{IN}) absorbs the input switching current, it requires an adequate ripple current rating. The RMS current in the input capacitor can be estimated with Equation (2):

$$I_{CIN} = I_{LOAD} \times \sqrt{\frac{V_{OUT}}{V_{IN}} \times \left(1 - \frac{V_{OUT}}{V_{IN}}\right)} \quad (2)$$

The worst-case condition occurs at V_{IN} = 2 x V_{OUT}, calculated with Equation (3):

$$I_{CIN} = \frac{I_{LOAD}}{2} \quad (3)$$

For simplification, choose an input capacitor with an RMS current rating greater than half of the maximum load current.

The input capacitor can be electrolytic, tantalum, or ceramic. When using electrolytic or tantalum capacitors, add a small, high-quality ceramic capacitor (e.g. 0.1 μ F) as close to the IC as possible. When using ceramic capacitors, ensure that they have enough capacitance to provide a sufficient charge to prevent excessive voltage ripple at the input. The input voltage ripple caused by the capacitance can be estimated with Equation (4):

$$\Delta V_{IN} = \frac{I_{LOAD}}{f_{SW} \times C_{IN}} \times \frac{V_{OUT}}{V_{IN}} \times \left(1 - \frac{V_{OUT}}{V_{IN}}\right) \quad (4)$$

GND Connection (PGND, Pin 6 and 11; AGND Pin 15)

See the PCB Layout Guidelines section on page 63 for more details.

Floating Driver and Bootstrap Charging (BST, Pin 7)

The BST capacitor (C7) is recommended to be 0.22 μ F.

The bootstrap capacitor is charged and regulated to about 3.3V by the dedicated internal bootstrap regulator. When the voltage between the BST and SW nodes is below its regulation

value, a transistor connected from VDRV to BST turns on to charge the bootstrap capacitor.

When the HS-FET is on, the BST voltage exceeds the VDRV voltage, so the bootstrap capacitor cannot be charged. At higher duty cycles, the time available for bootstrap charging is shorter, so the bootstrap capacitor may not be charged sufficiently. In this scenario, the bootstrap refresh circuit turns the HS-FET off and turns the LS-FET on to ensure that the bootstrap capacitor is correctly charged.

Selecting the Inductor and Output Capacitor (SW, Pin 8 and 9)

Selecting the Output Capacitor

The output voltage ripple can be calculated with Equation (5):

$$\Delta V_{OUT} = \frac{V_{OUT}}{f_{SW} \times L} \times \left(1 - \frac{V_{OUT}}{V_{IN}}\right) \times \left(R_{ESR} + \frac{1}{8 \times f_{SW} \times C_{OUT}}\right) \quad (5)$$

Where L is the inductor value and R_{ESR} is the equivalent series resistance (ESR) value of the output capacitor.

For ceramic capacitors, the capacitance dominates the impedance at the switching frequency and causes the majority of the output voltage ripple. For simplification, the output voltage ripple can be estimated with Equation (6):

$$\Delta V_{OUT} = \frac{V_{OUT}}{8 \times f_{SW}^2 \times L \times C_{OUT}} \times \left(1 - \frac{V_{OUT}}{V_{IN}}\right) \quad (6)$$

For tantalum or electrolytic capacitors, the ESR dominates the impedance at the switching frequency. For simplification, the output ripple can be calculated with Equation (7):

$$\Delta V_{OUT} = \frac{V_{OUT}}{f_{SW} \times L} \times \left(1 - \frac{V_{OUT}}{V_{IN}}\right) \times R_{ESR} \quad (7)$$

The characteristics of the output capacitor also affect the stability of the regulation system. The MPQ2286 can be optimized for a wide range of capacitance and ESR values.

Selecting the Inductor

An inductor with a DC current rating at least 25% higher than the maximum load current is recommended for most applications. For higher efficiency, choose an inductor with a lower DC resistance. A larger-value inductor results in less

ripple current and a lower output ripple voltage, but also has a larger physical size, higher series resistance, and lower saturation current. A good rule to determine the inductance is to allow the inductor ripple current to be approximately 30% of the maximum load current. The inductance can then be estimated with Equation (8):

$$L = \frac{V_{OUT}}{f_{SW} \times \Delta I_L} \times \left(1 - \frac{V_{OUT}}{V_{IN}}\right) \quad (8)$$

Where ΔI_L is the peak-to-peak inductor ripple current.

Choose the inductor ripple current to be approximately 30% of the maximum load current. The maximum inductor peak current can be calculated with Equation (9):

$$I_{LP} = I_{LOAD} + \frac{V_{OUT}}{2 \times f_{SW} \times L} \times \left(1 - \frac{V_{OUT}}{V_{IN}}\right) \quad (9)$$

Internal LDO Output (VDRV, Pin 10)

The VDRV capacitor's (C14) value is recommended to be about 4.6 μ F. The HS and LS drive circuits are powered by the internal VDRV regulator. This regulator uses V_{IN} as its input and operates across the full V_{IN} range. When V_{IN} exceeds 3.3V, VDRV is in full regulation. When V_{IN} is below 3.3V, the VDRV output degrades.

Power Good (PG) Indicator (PG, Pin 13)

The PG pin is an open-drain output. If using PG, connect it to the VCC voltage via a pull-up resistor (R5, which is recommend to be about 100k Ω). PG asserts (pull low) if the power is outside of the PG thresholds. The PG threshold can be configured by writing to PG_CONFIG (D0h), bit[0] (PG_THRESHOLD). The PG threshold is $\pm 4\%$ when PG_THRESHOLD is set to 0. The PG threshold is $\pm 6\%$ when PG_THRESHOLD is set to 6.

Supply Input for Internal Analog and Digital Circuits (VCC, Pin 14)

Connect the VDRV supply to the VCC pin with a 2.2 Ω resistor, and decouple the VCC pin with a 2.2 μ F capacitor connected to AGND. The internal analog and digital circuits are powered by VCC, except for the HS and LS drive circuits.

SYNC Output (SYNCOUT, Pin 16)

The pin can output the internal clock with 0° or 180° phase shift. This phase shift can be configured via FREQUENCY_SET (CBh), bit[2] (SYNCO_PHASE).

Digital Interface (SDA, Pin 17; SCL, Pin 18)

The MPQ2286 works as a slave-only device which supports both the standard mode (100kbps) and fast mode (400kbps) bidirectional data transfer, adding flexibility to the power supply solution. Refer to the Digital Interface section for details.

The SCL and SDA lines are externally pulled to a bus voltage with resistor (e.g. 1.5kΩ).

PCB Layout Guidelines ⁽¹²⁾

Efficient PCB layout, especially for input capacitor placement, is critical for stable operation. A 4-layer layout is strongly recommended to improve thermal performance. For the best results, refer to Figure 12 and follow the guidelines below:

1. Place the symmetric input capacitors as close to VIN and GND as possible.
2. Use a large ground plane to connect to PGND directly.
3. Ensure that the high-current paths at GND and VIN have short, direct, and wide traces.
4. Place the ceramic input capacitor, especially the small package size (0603) input bypass capacitor, as close to VIN and PGND as possible to minimize high-frequency noise.
5. Keep the connection between the input capacitor and VIN as short and wide as possible.
6. Place the VCC capacitor as close to VCC and GND as possible.
7. Route SW away from sensitive analog areas, such as FB.
8. Ensure that the trace between FB and the output is as short as possible.
9. Use multiple vias to connect the power planes to the internal layers.

Notes:

- 12) The recommended PCB layout is based on Figure 13 on page 64.

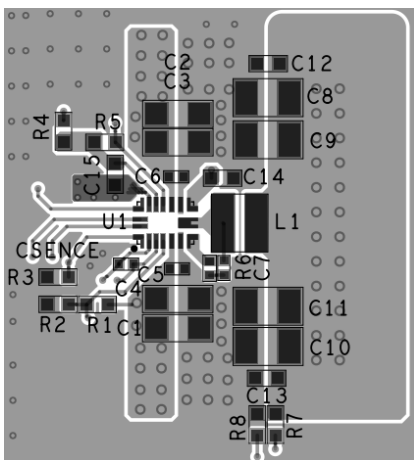
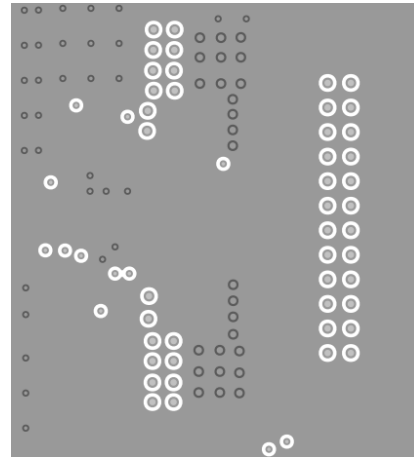
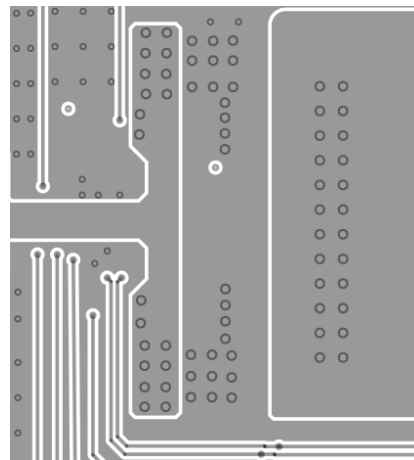
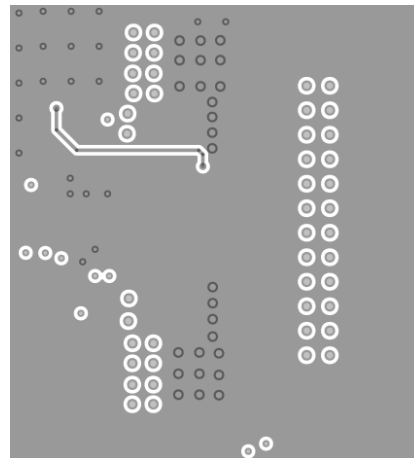
Top Layer

Mid-Layer 1

Mid-Layer 2

Bottom Layer
Figure 12: Recommended PCB Layout

TYPICAL APPLICATION CIRCUITS

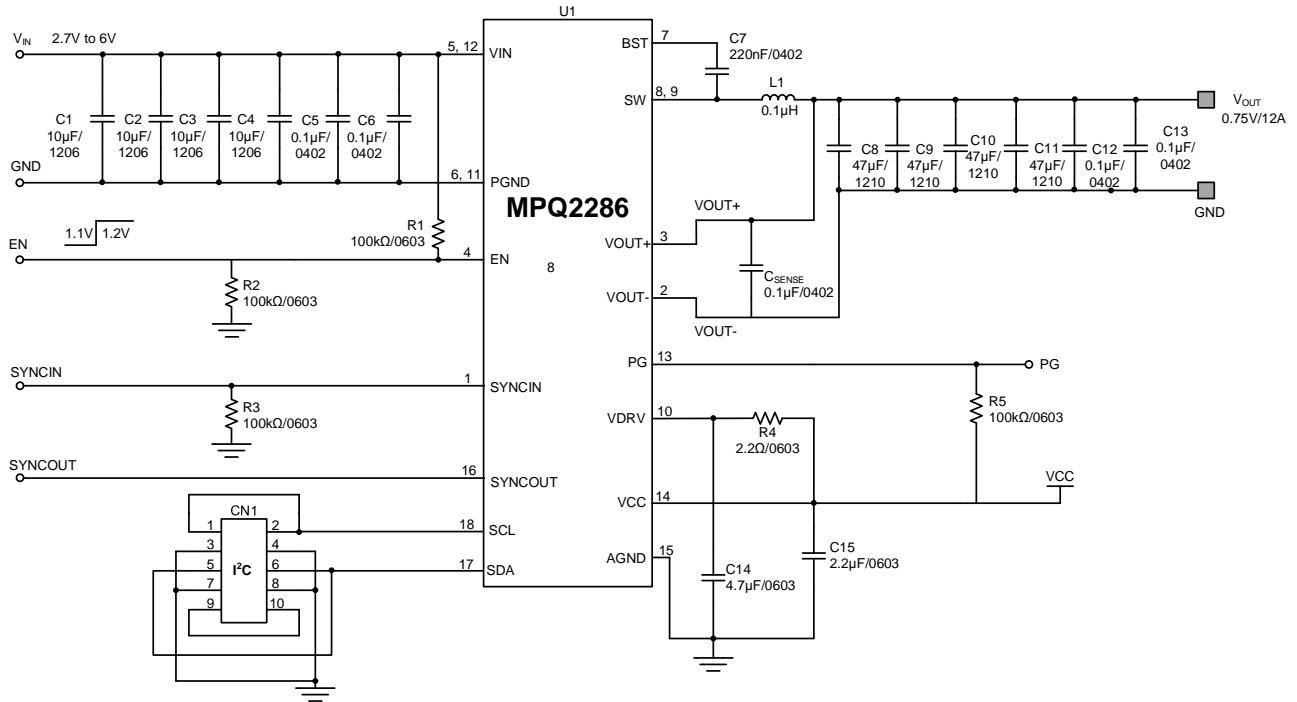

Figure 13: Typical Application Circuit ($V_{OUT} = 0.75V$, $I_{OUT} = 12A$, $f_{sw} = 3MHz$)

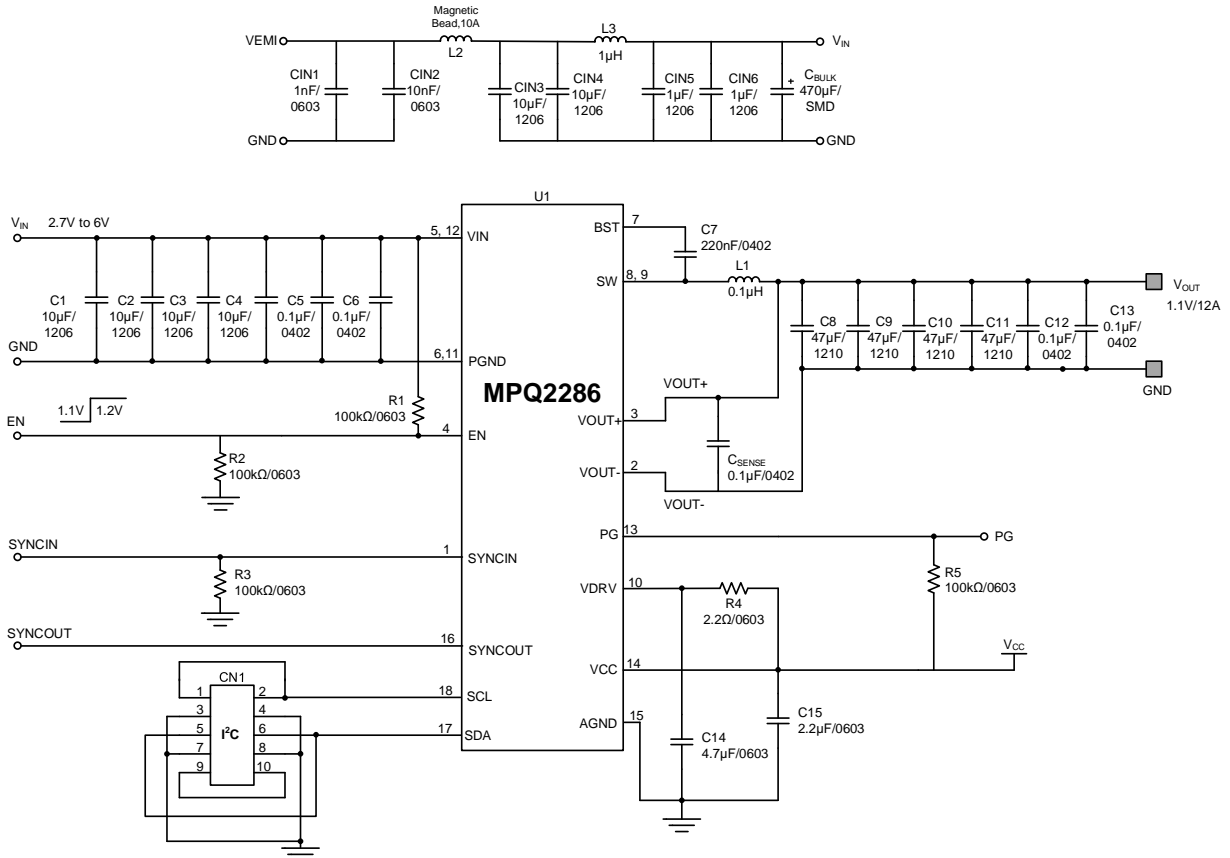
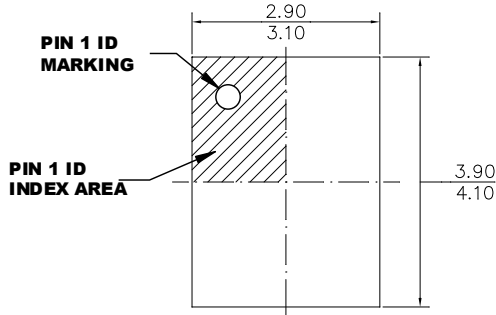

Figure 14: Typical Application Circuit ($V_{OUT} = 1.1V$, $I_{OUT} = 12A$, $f_{sw} = 4MHz$ with EMI Filter)

PACKAGE INFORMATION

QFN-18 (3mmx4mm) Wettable Flank



TOP VIEW

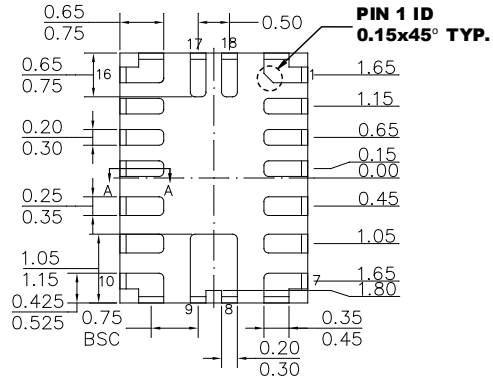

BOTTOM VIEW

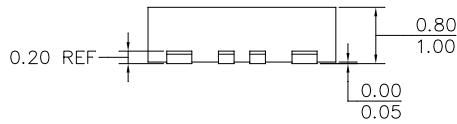

SIDE VIEW

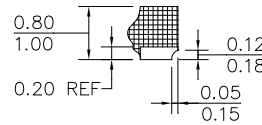

SECTION A-A

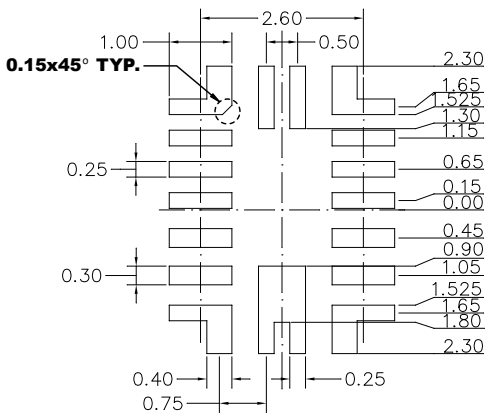

RECOMMENDED LAND PATTERN

NOTE:

- 1) THE LEAD SIDE IS WETTABLE.
- 2) ALL DIMENSIONS ARE IN MILLIMETERS.
- 3) LEAD COPLANARITY SHALL BE 0.08 MILLIMETERS MAX.
- 4) JEDEC REFERENCE IS MO-220.
- 5) DRAWING IS NOT TO SCALE.

CARRIER INFORMATION

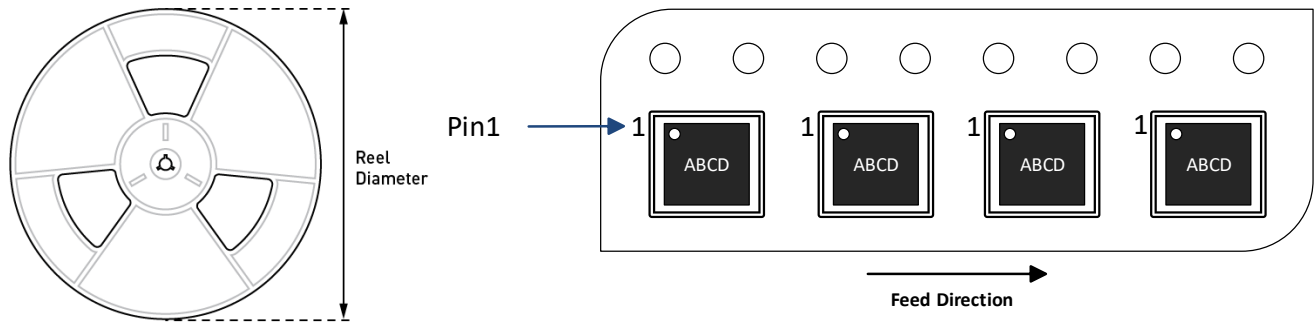

Part Number	Package Description	Quantity/ Reel	Quantity/ Tube	Quantity/ Tray	Reel Diameter	Carrier Tape Width	Carrier Tape Pitch
MPQ2286GLE-xxxx-AEC1-Z	QFN-18 (3mmx4mm)	5000	N/A	N/A	13in	12mm	8mm

REVISION HISTORY

Revision #	Revision Date	Description	Pages Updated
1.0	10/30/2023	Initial Release	-

Notice: The information in this document is subject to change without notice. Please contact MPS for current specifications. Users should warrant and guarantee that third-party Intellectual Property rights are not infringed upon when integrating MPS products into any application. MPS will not assume any legal responsibility for any said applications.