

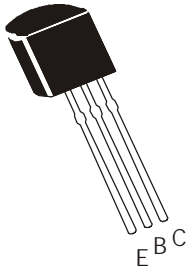

NPN EPITAXIAL PLANAR SILICON TRANSISTORS

MPSA 42
MPSA 43
TO-92
CBE



High Voltage Transistors.

ABSOLUTE MAXIMUM RATINGS(Ta=25deg C unless otherwise specified)

DESCRIPTION	SYMBOL	MPSA42	MPSA43	UNIT
Collector -Emitter Voltage	VCEO	300	200	V
Collector -Base Voltage	VCBO	300	200	V
Emitter -Base Voltage	VEBO		6	V
Collector Current Continuous	IC		500	mA
Power Dissipation @ Ta=25 degC	PD		625	mW
Derate above 25 deg C			5	mW./deg C
Power Dissipation @ Tc=25 degC	PD		1.5	W
Derate above 25 deg C			12	mW./deg C
Operating And Storage Junction Temperature Range	Tj, Tstg		-55 to +150	deg C

THERMAL RESISTANCE

Junction to Case	Rth(j-c)		83.3	deg C/W
Junction to Ambient	Rth(j-a)		200	deg C/W

ELECTRICAL CHARACTERISTICS (Ta=25 deg C Unless Otherwise Specified)

DESCRIPTION	SYMBOL	TEST CONDITION	MPSA42	MPSA43	UNIT
Collector -Emitter Voltage	VCEO	IC=1mA, IB=0	>300	>200	V
Collector -Base Voltage	VCBO	IC=100uA, IE=0	>300	>200	V
Emitter-Base Voltage	VEBO	IE=100uA, IC=0	>6.0	>6.0	V
Collector-Cut off Current	ICBO	VCB=200V, IE=0	<100	-	nA
		VCB=160V, IE=0	-	<100	nA
Emitter-Cut off Current	IEBO	VEB=6V, IC=0	<100	-	nA
		VEB=4V, IC=0	-	<100	nA
DC Current Gain	hFE*	IC=1mA, VCE=10V	>25	>25	
		IC=10mA, VCE=10V	>40	>40	
		IC=30mA, VCE=10V	>40	>40	
Collector Emitter Saturation Voltage	VCE(Sat)*	IC=20mA, IB=2mA	<0.5	<0.4	V
Base Emitter Saturation Voltage	VBE(Sat) *	IC=20mA, IB=2mA	<0.9	<0.9	V
DYNAMIC CHARACTERISTICS					
Current Gain-Bandwidth Product	ft	IC=10mA, VCE=20V f=100MHz	>50	>50	MHz
Collector Base Capacitance	Ccb	VCB=20V, IE=0 f=1MHz	<3.0	<4.0	pF

*Pulse Test: Pulse Width=300us, Duty Cycle=2%

TO-92 Plastic Package

TO-92 Transistors on Tape and Ammo Pack

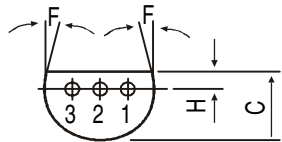
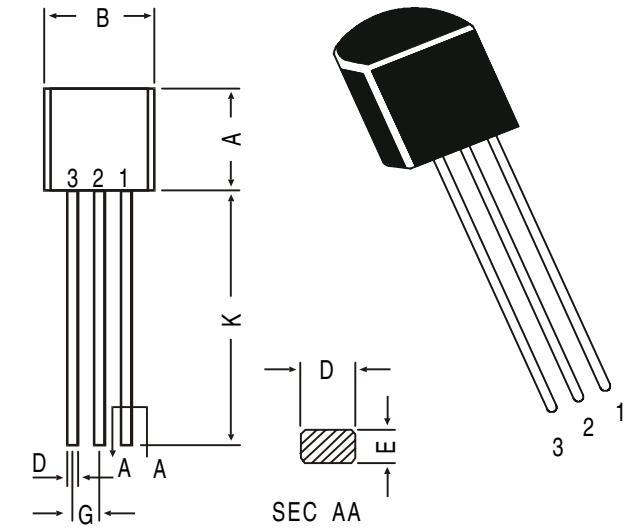

- PIN CONFIGURATION**
1. COLLECTOR
 2. BASE
 3. EMITTER

All dimensions in mm.

DIM	MIN.	MAX.
A	4.32	5.33
B	4.45	5.20
C	3.18	4.19
D	0.41	0.55
E	0.35	0.50
F	5 DEG	
G	1.14	1.40
H	1.14	1.53
K	12.70	—

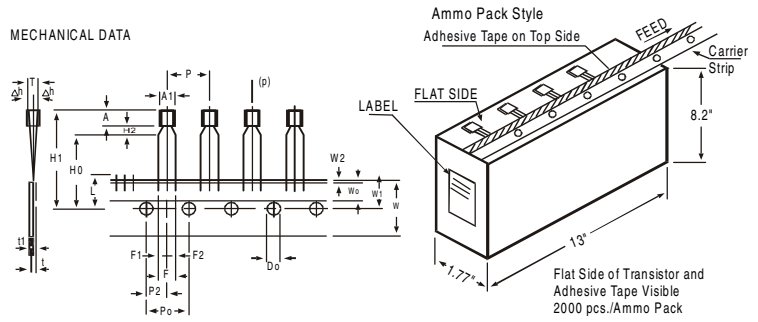

All dimensions in mm unless specified otherwise

ITEM	SYMBOL	SPECIFICATION				REMARKS
		MIN.	NOM.	MAX.	TOL.	
BODY WIDTH	A1	4.0		4.8		
BODY HEIGHT	A	4.8		5.2		
BODY THICKNESS	T	3.9		4.2		
PITCH OF COMPONENT	P		12.7		±1	
FEED HOLE PITCH	Po		12.7		±0.3	CUMULATIVE PITCH ERROR 1.0 mm/20 PITCH
FEED HOLE CENTRE TO COMPONENT CENTRE	P2		6.35		±0.4	TO BE MEASURED AT BOTTOM OF CLINCH
DISTANCE BETWEEN OUTER LEADS	F	5.08			+0.6 -0.2	
COMPONENT ALIGNMENT	Δh	0	1			AT TOP OF BODY
TAPE WIDTH	W	18			±0.5	
HOLD-DOWN TAPE WIDTH	W0	6			±0.2	
HOLE POSITION	W1	9			+0.7 -0.5	
HOLD-DOWN TAPE POSITION	W2	0.5			±0.2	
LEAD WIRE CLINCH HEIGHT	Ho	16			±0.5	
COMPONENT HEIGHT	H1		23.25			
LENGTH OF SNIPPED LEADS	L		11.0			
FEED HOLE DIAMETER	Do	4			±0.2	
TOTAL TAPE THICKNESS	t		1.2			±0.3 - 0.6
LEAD - TO - LEAD DISTANCE ¹	F2	2.54			+0.4 -0.1	
CLINCH HEIGHT	H2			3		
PULL - OUT FORCE	(P)	6N				

NOTES

1. MAXIMUM ALIGNMENT DEVIATION BETWEEN LEADS NOT TO BE GREATER THAN 0.2 mm.
2. MAXIMUM NON-CUMULATIVE VARIATION BETWEEN TAPE FEED HOLES SHALL NOT EXCEED 1 mm IN 20 PITCHES.
3. HOLDDOWN TAPE NOT TO EXCEED BEYOND THE EDGE(S) OF CARRIER TAPE AND THERE SHALL BE NO EXPOSURE OF ADHESIVE.
4. NO MORE THAN 3 CONSECUTIVE MISSING COMPONENTS ARE PERMITTED.
5. A TAPE TRAILER, HAVING AT LEAST THREE FEED HOLES ARE REQUIRED AFTER THE LAST COMPONENT.
6. SPLICES SHALL NOT INTERFERE WITH THE SPROCKET FEED HOLES.

Packing Detail

PACKAGE	STANDARD PACK		INNER CARTON BOX		OUTER CARTON BOX		
	Details	Net Weight/Qty	Size	Qty	Size	Qty	Gr Wt
TO-92 Bulk	1K/polybag	200 gm/1K pcs	3" x 7.5" x 7.5"	5.0K	17" x 15" x 13.5"	80.0K	23 kgs
TO-92 T&A	2K/ammo box	645 gm/2K pcs	12.5" x 8" x 1.8"	2.0K	17" x 15" x 13.5"	32.0K	12.5 kgs