

# StickIt! MPU-9150 Manual

*How to install and use your new  
StickIt! MPU-9150 Module*

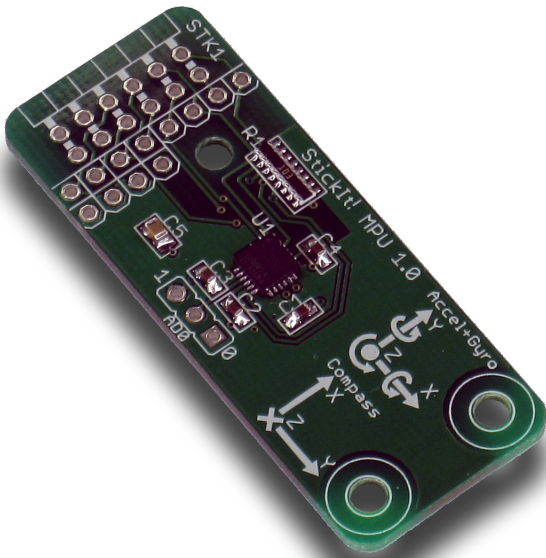

[www.datasheet4u.com](http://www.datasheet4u.com)

XESS is disclosing this Document and Intellectual Property (hereinafter “the Design”) to you for use in the development of designs to operate on, or interface with XESS hardware devices. XESS expressly disclaims any liability arising out of the application or use of the Design. XESS reserves the right to make changes, at any time, to the Design as deemed desirable in the sole discretion of XESS. XESS assumes no obligation to correct any errors contained herein or to advise you of any correction if such be made. XESS will not assume any liability for the accuracy or correctness of any engineering or technical support or assistance provided to you in connection with the Design.

THE DESIGN IS PROVIDED “AS IS” WITH ALL FAULTS, AND THE ENTIRE RISK AS TO ITS FUNCTION AND IMPLEMENTATION IS WITH YOU. YOU ACKNOWLEDGE AND AGREE THAT YOU HAVE NOT RELIED ON ANY ORAL OR WRITTEN INFORMATION OR ADVICE, WHETHER GIVEN BY XESS, OR ITS AGENTS OR EMPLOYEES. XESS MAKES NO OTHER WARRANTIES, WHETHER EXPRESS, IMPLIED, OR STATUTORY, REGARDING THE DESIGN, INCLUDING ANY WARRANTIES OF MERCHANTABILITY, FITNESS FOR A PARTICULAR PURPOSE, TITLE, AND NONINFRINGEMENT OF THIRD-PARTY RIGHTS.

IN NO EVENT WILL XESS BE LIABLE FOR ANY CONSEQUENTIAL, INDIRECT, EXEMPLARY, SPECIAL, OR INCIDENTAL DAMAGES, INCLUDING ANY LOST DATA AND LOST PROFITS, ARISING FROM OR RELATING TO YOUR USE OF THE DESIGN, EVEN IF YOU HAVE BEEN ADVISED OF THE POSSIBILITY OF SUCH DAMAGES. THE TOTAL CUMULATIVE LIABILITY OF XESS IN CONNECTION WITH YOUR USE OF THE DESIGN, WHETHER IN CONTRACT OR TORT OR OTHERWISE, WILL IN NO EVENT EXCEED THE AMOUNT OF FEES PAID BY YOU TO XESS HEREUNDER FOR USE OF THE DESIGN. YOU ACKNOWLEDGE THAT THE FEES, IF ANY, REFLECT THE ALLOCATION OF RISK SET FORTH IN THIS AGREEMENT AND THAT XESS WOULD NOT MAKE AVAILABLE THE DESIGN TO YOU WITHOUT THESE LIMITATIONS OF LIABILITY.

The Design is not designed or intended for use in the development of on-line control equipment in hazardous environments requiring fail-safe controls, such as in the operation of nuclear facilities, aircraft navigation or communications systems, air traffic control, life support, or weapons systems (“High-Risk Applications”). XESS specifically disclaims any express or implied warranties of fitness for such High-Risk Applications. You represent that use of the Design in such High-Risk Applications is fully at your risk.

© 2014 XESS, Inc. XESS, the XESS logo, and other designated brands included herein are trademarks of XESS Corporation. PMOD is a trademark of Digilent Inc. All other trademarks are the property of their respective owners.



This document is licensed under the Attribution-ShareAlike 3.0 Unported license, available at <http://creativecommons.org/licenses/by-sa/3.0/>.

---

**StickIt! MPU-9150 Manual**  
**MAN012 (V1.0) March 4, 2014**

The following table shows the revision history for this document.

Date	Version	Revision
03/04/14	1.0	Initial release for StickIt! MPU-9150 module V1.0.

# Table of Contents

- C.1 Preliminaries..... 1**
  - Getting Help!..... 1
  - Take Notice!..... 1
  - Packing List..... 1
- C.2 Setup..... 2**
  - Inserting Your StickIt! MPU-9150 Module Into Your StickIt! Board..... 2
    - Inserting Into a PMOD Socket..... 2
    - Inserting Into a Wing Socket..... 3
  - Setting the Address Jumper..... 4
- C.3 Operation..... 5**
- C.4 Using the Module..... 6**
- A.1 I/O Locations..... 7**
- A.2 Schematic..... 8**

# C.1 Preliminaries

---

Here's some helpful information before getting started.

## Getting Help!

Here are some places to get help if you encounter problems:

- If you can't get the StickIt! MPU-9150 module to work, send an e-mail message describing your problem to [help@xess.com](mailto:help@xess.com) or submit a problem report at <http://www.xess.com/help.php>.
- Our web site also has
  - answers to frequently-asked-questions,
  - example designs, application notes and tutorials,
  - a forum where you can post questions.

## Take Notice!

This module is meant to be powered by 3.3V and should only be powered by 3.3V.

## Packing List

Here is what you should have received in your package:

- a StickIt! MPU-9150 module.
- PMOD™ male header.
- Wing male headers (8-pin & 4-pin).

## C.2 Setup

The StickIt! MPU-9150 module contains an [integrated three-axis accelerometer, three-axis gyroscope, three-axis compass and temperature sensor](#) that connects to an eight-bit PMOD or a Wing socket on your StickIt! board.

### Inserting Your StickIt! MPU-9150 Module Into Your StickIt! Board

#### Inserting Into a PMOD Socket

To use the StickIt! MPU-9150 module with a PMOD socket, first solder the included male PMOD header to the module as shown. (**To insure a stable connection, only use a header with 0.025" square pins.**)

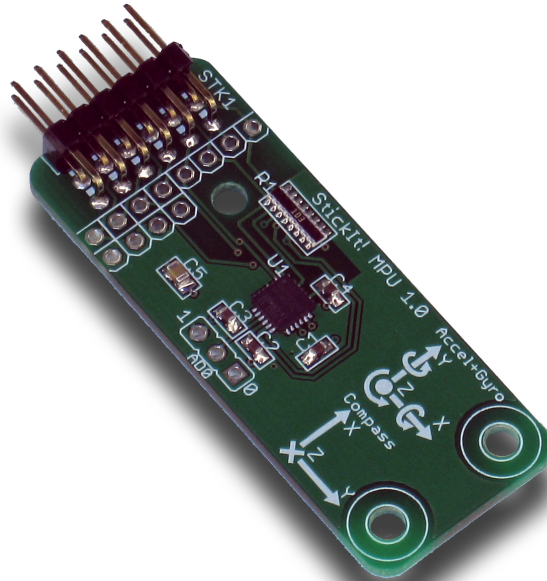

Then insert the module into one of the PMOD sockets on the StickIt! Board.

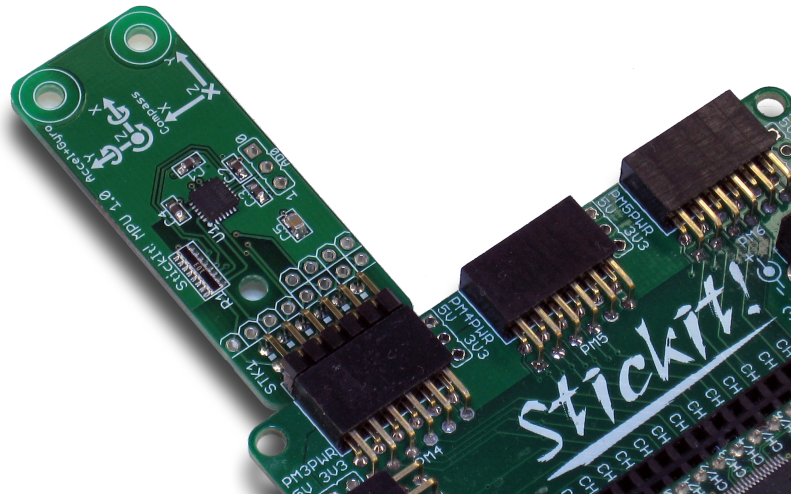

### Inserting Into a Wing Socket

To use the StickIt! MPU-9150 module with a Wing socket, first solder the included male Wing headers to the module as shown. (**To insure a stable connection, only use a header with 0.025" square pins.**)

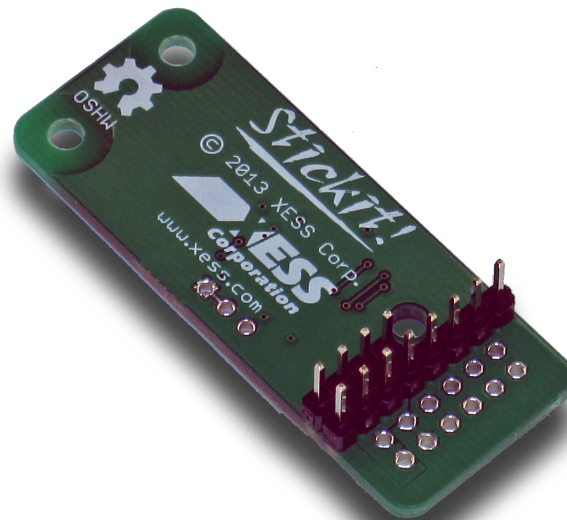

Then insert the module into one of the eight-bit Wing sockets on the StickIt! board.

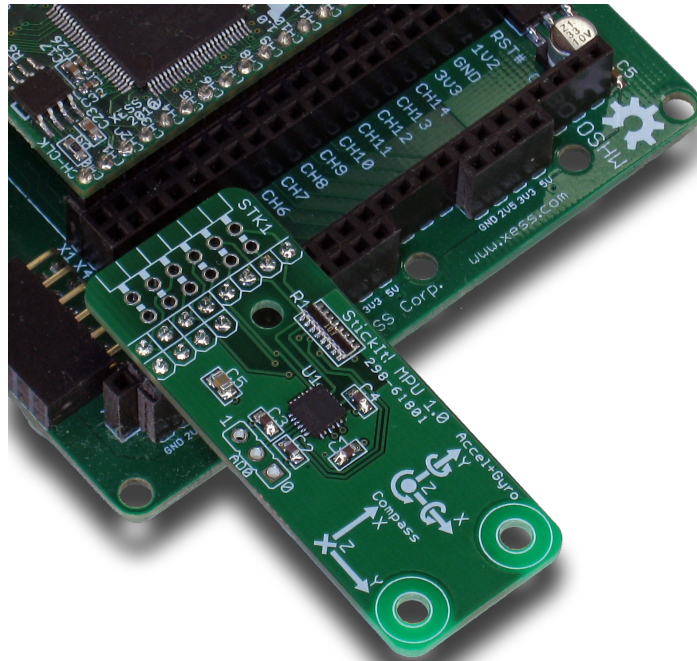

## Setting the Address Jumper

The AD0 jumper sets the least-significant bit of the MPU-9150 I<sup>2</sup>C address. By default, the jumper is set to 0 (giving an address of 0x68) by a shorting trace on the backside of the PCB. This trace must be cut if you want to change the address to 0x69 by placing a shunt on the '1' position of AD0.





## C.3 Operation

This chapter describes the operation of the StickIt! MPU-9150 module using a simplified schematic. You can find a complete [schematic](#) at the end of this manual.

There are six pins of the MPU chip that you can control. The SCL and SDA pins provide the main I<sup>2</sup>C communication path to-and-from the chip. The AD0 jumper sets the I<sup>2</sup>C address to be either 0x68 or 0x69. Most of your interactions with the MPU will occur through the I<sup>2</sup>C interface.

The use of the remaining pins is optional. An interrupt output (INT) can be used to alert external systems about changes sensed by the MPU. The internal clock of the chip can be overridden by a clock signal supplied on the CLKIN input. The FSYNC input can be used to synchronize the MPU with external systems.

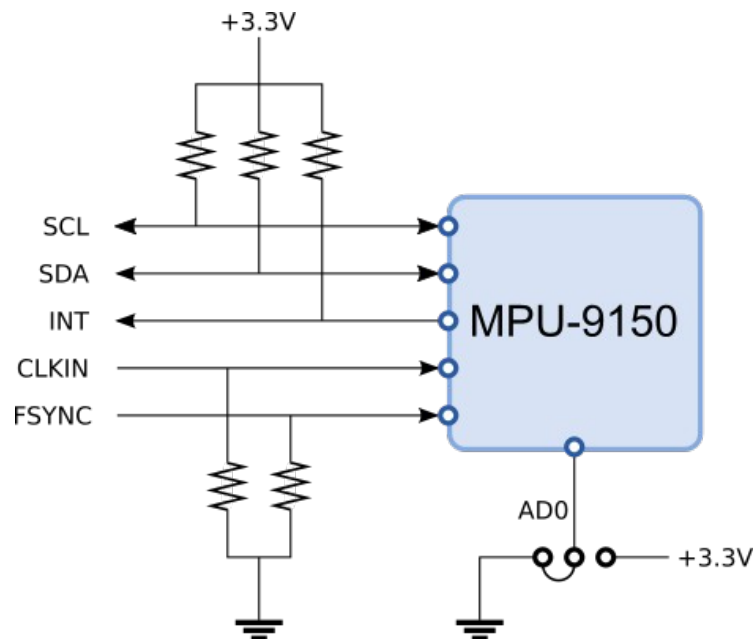

## C.4 Using the Module

---

To use the StickIt! MPU-9150 module, you will need to do the following:

- Create a Xilinx ISE FPGA project that contains (among other things) an I<sup>2</sup>C master module for controlling the MPU and reading the accelerometer, gyroscope and temperature sensors. The project can also have circuitry for handling the INT, CLKIN and FSYNC pins of the MPU, but it's not necessary. You will find the information in the MPU-9150 [datasheet](#) and [register map](#) invaluable for this portion of the design process.
- Allocate from two to five pins to connect to the I/O signals (at least SCL and SDA) of the module.
- Attach the module to either a PMOD or Wing socket on the StickIt! board.
- Determine the channel signals on the PMOD or Wing socket that connect to each I/O pin of the module.
- Find which FPGA pin of the XuLA board connects to each channel signal. (You can find this information in the StickIt! Board manual.)
- Make a UCF file associating each FPGA pin with an I/O pin of the module.
- Include the UCF file in your ISE project.

**That's a lot of work, so we've built an example for you.** Just go to <http://github.com/xesscorp/StickIt>. There, you will find a subdirectory with a Xilinx ISE project that includes:

- an example that gets the accelerometer, gyroscope and temperature sensor readings from the MPU and sends them back to the PC through the USB link,
- a UCF file containing the FPGA pin assignments to use when installing the StickIt! MPU-9150 module into any of the PMOD or Wing sockets,
- and a Python file that queries the MPU sensor readings and displays them on the PC.

# A.1 I/O Locations

The connections of the PMOD and Wing header I/O signals to the MPU chip on the StickIt! MPU-9150 module are shown below.

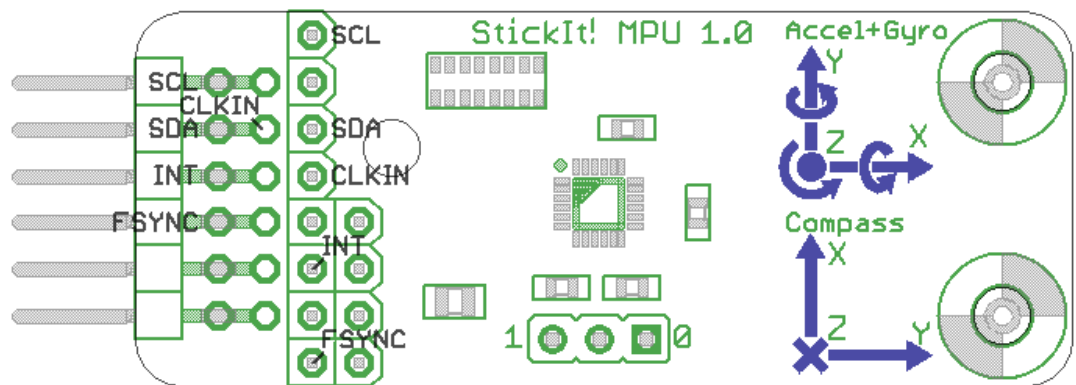

# A.2 Schematic

