MR45V100A

1M Bit(131,072-Word × 8-Bit) FeRAM (Ferroelectric Random Access Memory) SPI

GENERAL DESCRIPTION

The MR45V100A is a nonvolatile 128Kword x 8-bit ferroelectric random access memory (FeRAM) developed in the ferroelectric process and silicon-gate CMOS technology. The MR45V100A is accessed using Serial Peripheral Interface. Unlike SRAMs, this device, whose cells are nonvolatile, eliminates battery backup required to hold data. This device has no mechanisms of erasing and programming memory cells and blocks, such as those used for various EEPROMs. Therefore, the write cycle time can be equal to the read cycle time and the power consumption during a write can be reduced significantly.

The MR45V100A can be used in various applications, because the device is guaranteed for the write/read tolerance of 10^{13} cycles per bit and the rewrite count can be extended significantly.

FEATURES

- 131,072-word × 8-bit configuration (Serial Peripheral Interface: SPI)
- A single 1.8V to 3.6V (3.3V typ.) power supply
- Operating frequency: 34MHz(READ cycle) / 40MHz(Except for READ)
- Read/write tolerance: 10^{13} cycles/bit
- Data retention: 10 years
- Guaranteed operating temperature range: -40 to 85°C
- Low power consumption
 - Power supply current (@40MHz) 3.0mA(Typ.), 4.5mA(Max.)
 - Standby mode supply current 10µA(Typ.), 50µA(Max.)
 - Sleep mode supply current 0.1µA(Typ.), 2µA(Max.)
- Package options:
 - MR45V100AMA: 8-pin plastic SOP (P-SOP8-200-1.27-T2K)
 - MR45V100ARA: 8-pin plastic DIP (P-DIP8-300-2.54-T6)
- RoHS (Restriction of hazardous substances) compliant

PIN CONFIGURATION (Top View)

8-pin plastic SOP / DIP

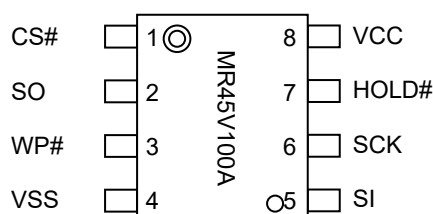

Note:

Signal names that end with # indicate that the signals are negative-true logic.

PIN DESCRIPTIONS

Pin Name	Description
CS#	Chip Select (input, negative logic) Latches an address by low input, activates the FeRAM, and enables read or write operation. High input goes the device disable state.
WP#	Write Protect(input, negative logic) Write Protect pin controls write-operation to the status-register(BP0,BP1). This pin should be fixed low or high in write-operations.
HOLD#	HOLD(input, negative logic) Hold pin is used when the serial-communication suspended without disable the chip select. When HOLD# is low, the serial-output is in High-Z status and serial-input/serial-clock are "Don't Care". CS# should be low in hold operation.
SCK	Serial Clock Serial Clock is the clock input pin for setting for serial data timing. Inputs are latched on the rising edge and outputs occur on the falling edge.
SI	Serial input SI pins are serial input pins for Operation-code, addresses, and data-inputs.
SO	Serial output SO pins are serial output pins.
VCC, VSS	Power supply Apply the specified voltage to V _{CC} . Connect V _{SS} to ground.

SPI MODE (Serial Peripheral Interface)

SPI mode0 (CPOL=0, CPHA=0)

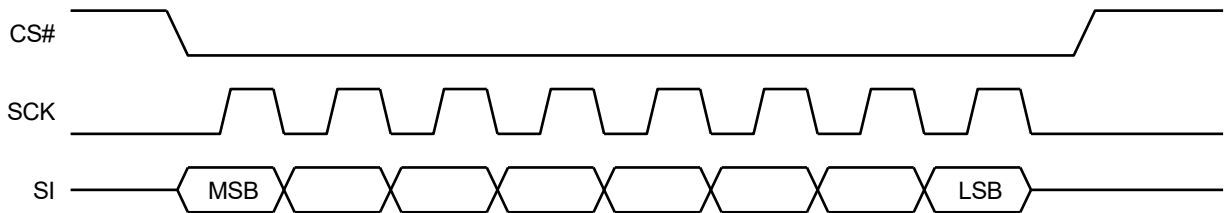

SPI mode3 (CPOL=1, CPHA=1)

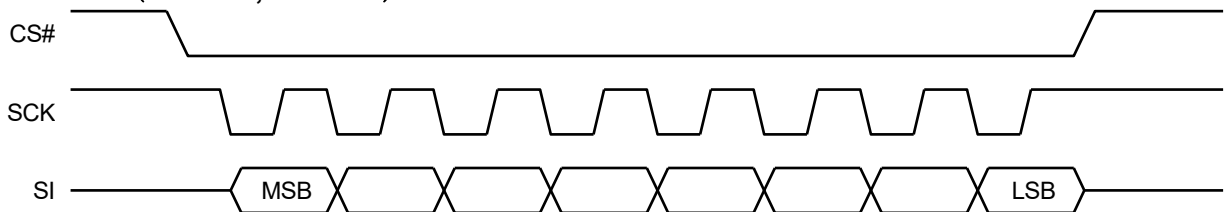

STATUS REGISTER

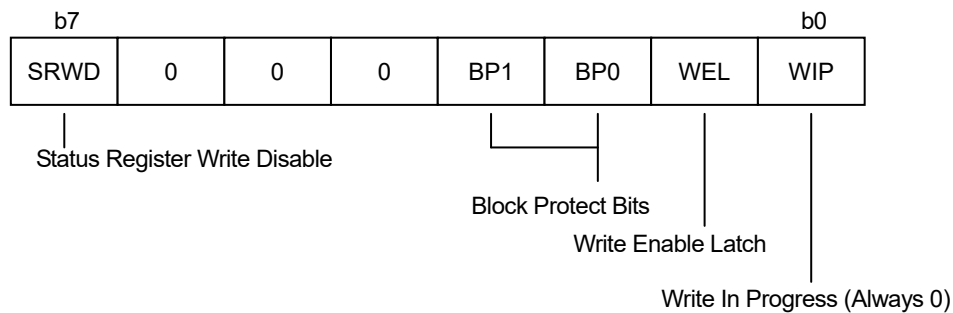

Name	Function
WIP	Fixed to 0.
WEL	WEL indicates internal Write Enable Latch status. The WEL is set after WREN command. After WRDI command, WRSR command, WRITE command, or Power on, the WEL can be reset.
BP0,BP1	Block Protect: These bits can change protected area. This is the software protect.
SRWD	Status Register Write Disable (SRWD): SRWD controls the effect of the hardware WP# pin. This device will be in hardware-protect by combination of SRWD and WP#.
0	Fixed to 0.

OPERATION-CODE

Operation codes are listed in the table below. If the device receives invalid operation code, the device will be deselected.

Instruction	Description	Instruction format
WREN	Write Enable	0000 0110
WRDI	Write Disable	0000 0100
RDSR	Read Status Register	0000 0101
WRSR	Write Status Register	0000 0001
READ	Read from Memory Array	0000 0011
WRITE	Write to Memory Array	0000 0010
FSTRD	Fast Read from Memory Array	0000 1011
RDID	Read device ID	1001 1111
SLEEP	Enter Sleep Mode	1011 1001

COMMANDS

WREN (Write Enable)

It is necessary to set Write Enable Latch (WEL) bit before write-operation (WRITE and WRSR).

WREN command sets WEL bit.

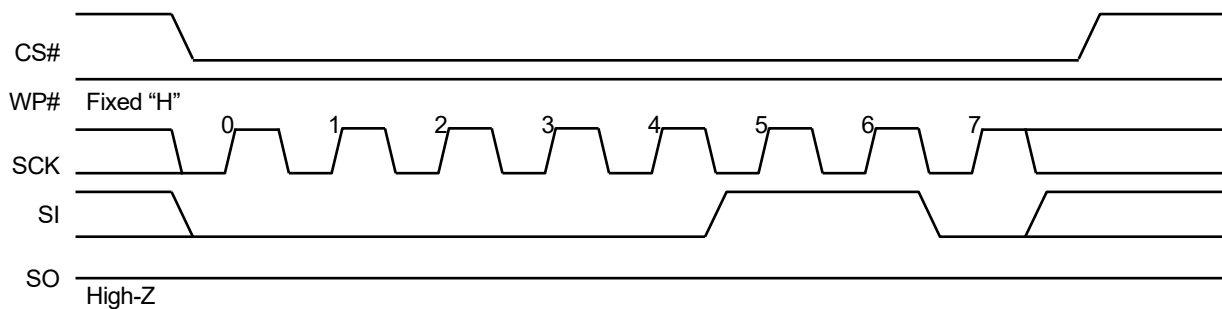

WRDI (Write Disable)

WRDI command resets WEL bit.

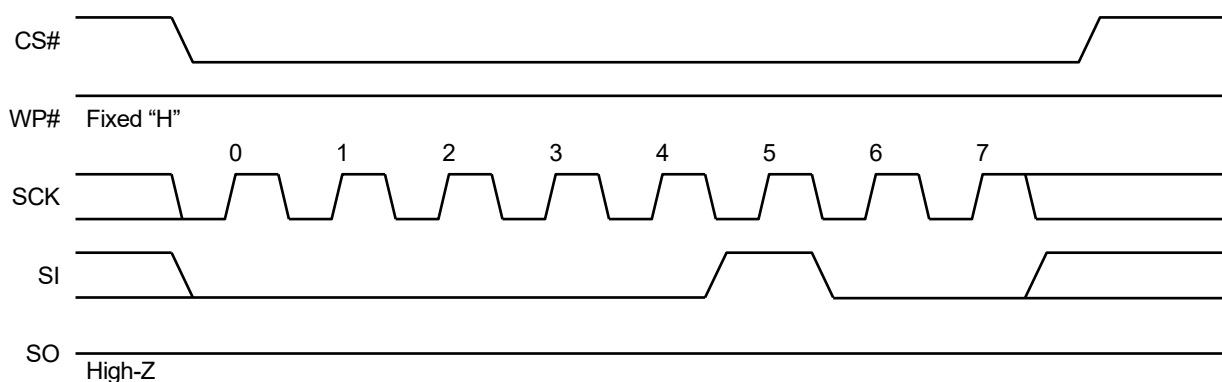

RDSR (READ Status Register)

The RDSR command allows reading data of status register. The Status Register can be read anytime and any number of times.

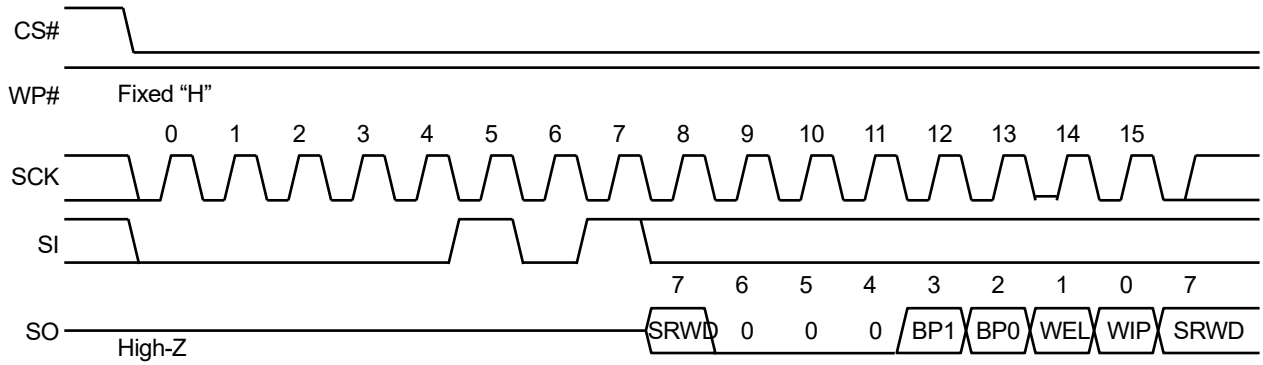

WRSR (WRITE Status Register)

WRSR command allows to write data to status register(SRWD,BP0,BP1). It is necessary to set Write Enable Latch (WEL) bit by WREN command before executing WRSR. WRSR command cannot write RFU(b6,b5,b4), WEL(b1), WIP(b0) of Status Register..

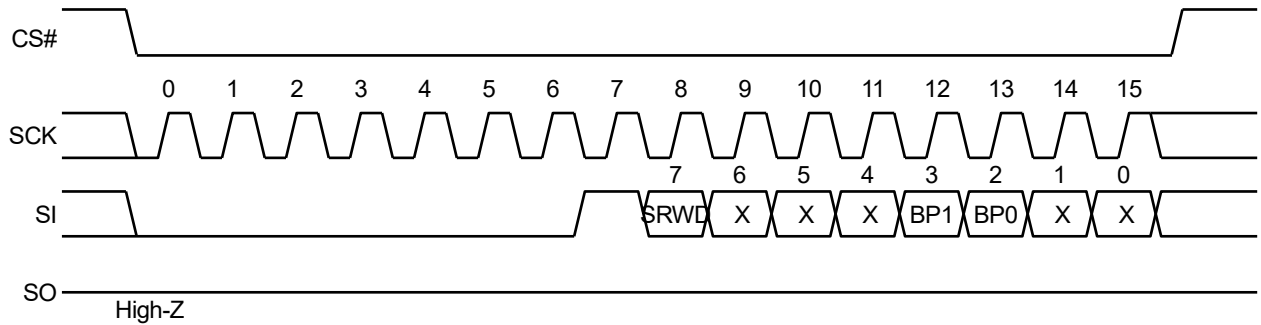

Note:
WP#=Fixed "H"

READ (Read from Memory Array)

READ command can be valid when CS# goes "L", then the op-code and 24bit-addresses are inputted to serial input "SI". The inputted addresses are loaded to internal register, then the data from corresponded address is outputted at serial-output "SO". If CS# will keep "L", the internal address will be increased automatically after 8 clocks and will output the data from new-address. When it reaches the most significant address, the address counter rolls over to starting address, and reading cycle can be continued infinitely. To finish read cycle, make the CS# "H" during LSB output clock.

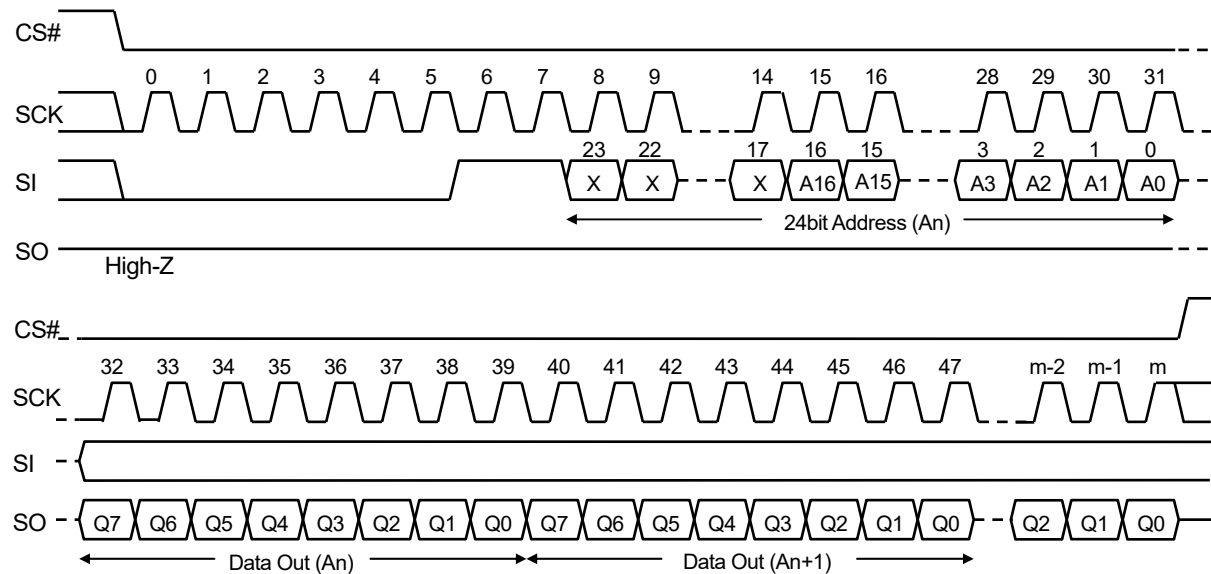

Note : WP# = fixed "H"

FSTRD (Fast Read from Memory Array)

FSTRD command can be valid when CS# goes "L", then the op-code and 24bit-addresses are inputted to serial input "SI". After 8bits for dummy byte, the data from corresponded address is outputted at serial-output "SO". If CS# will keep "L", the internal address will be increased automatically after 8 clocks and will output the data from new-address. When it reaches the most significant address, the address counter rolls over to starting address, and reading cycle can be continued infinitely. To finish read cycle, make the CS# "H" during LSB output clock.

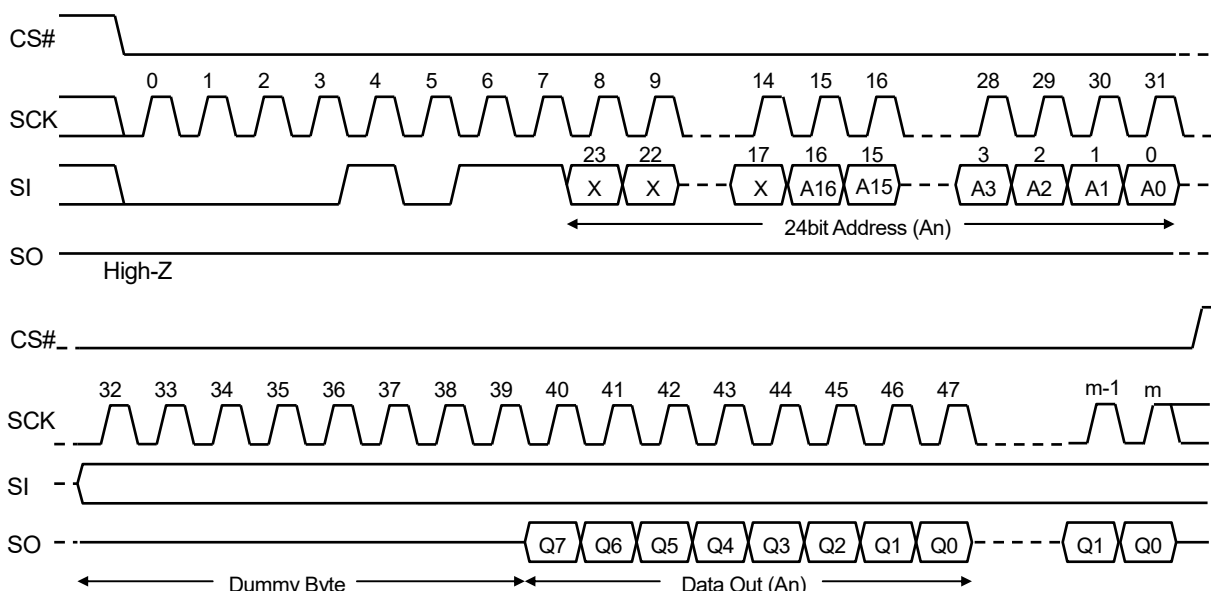

Note : WP# = fixed "H"

WRITE (Write to Memory Array)

Write command can be valid when CS# goes “L”, then the op-code and 24bit-addresses are inputted to serial input ”SI”. Writing is terminated when CS# goes high after data-input. If CS# will keep “L”, the internal address will be increased automatically. When it reaches the most significant address, the address counter rolls over to starting address 0000h, and writing cycle (overwriting) can be continued infinitely. To finish write cycle, make CS# “H” during LSB input clock.

WRITE (1Byte)

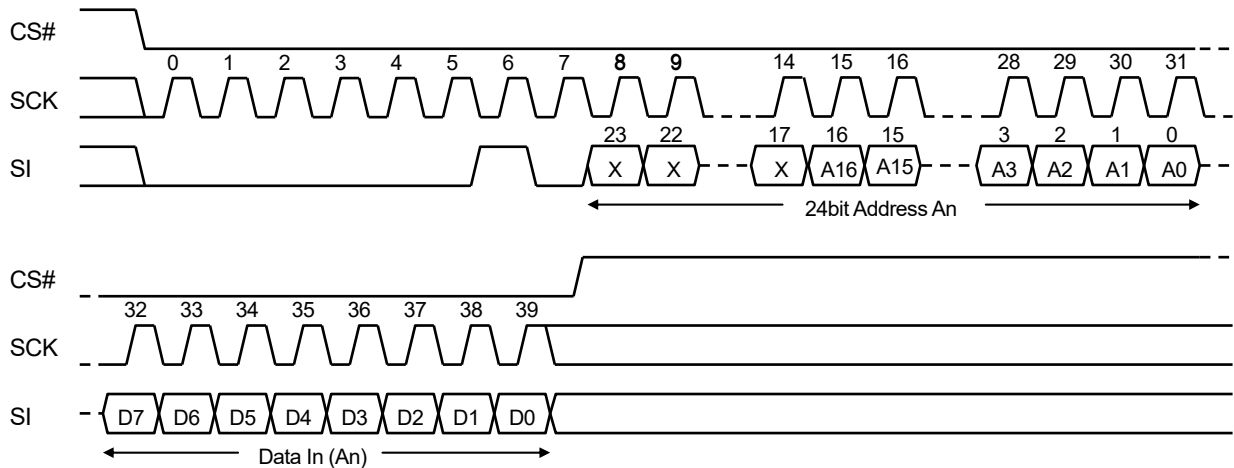

Note : WP# = Fixed "H" , SO=High-Z

WRITE (Page)

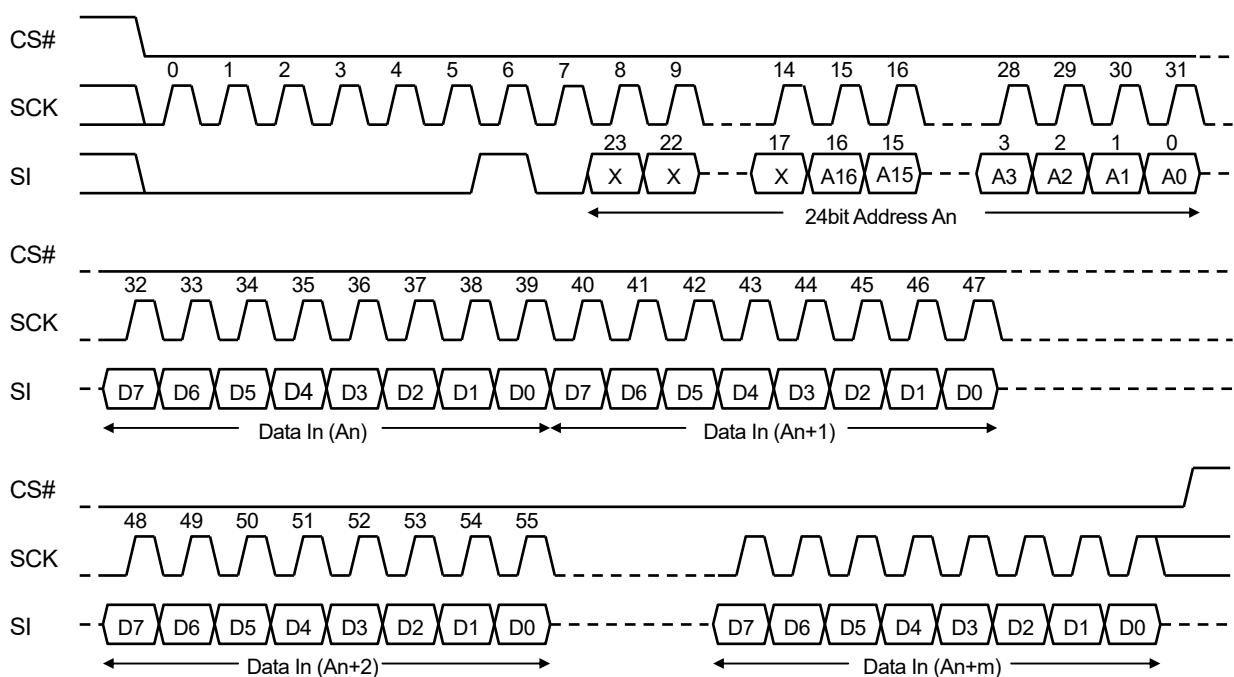

Note : WP# = Fixed "H" , SO=High-Z

RDID (Read device ID)

RDID command can be valid when CS# goes “L”, then the op-code are inputted to serial input ”SI”. Then 3bytes of device ID is output at serial-output “SO”.

Manufacture ID (LAPIS)	Device type (MR45V100A)	
1 st Byte	2 nd Byte	3 rd Byte
A Eh	83h	09h

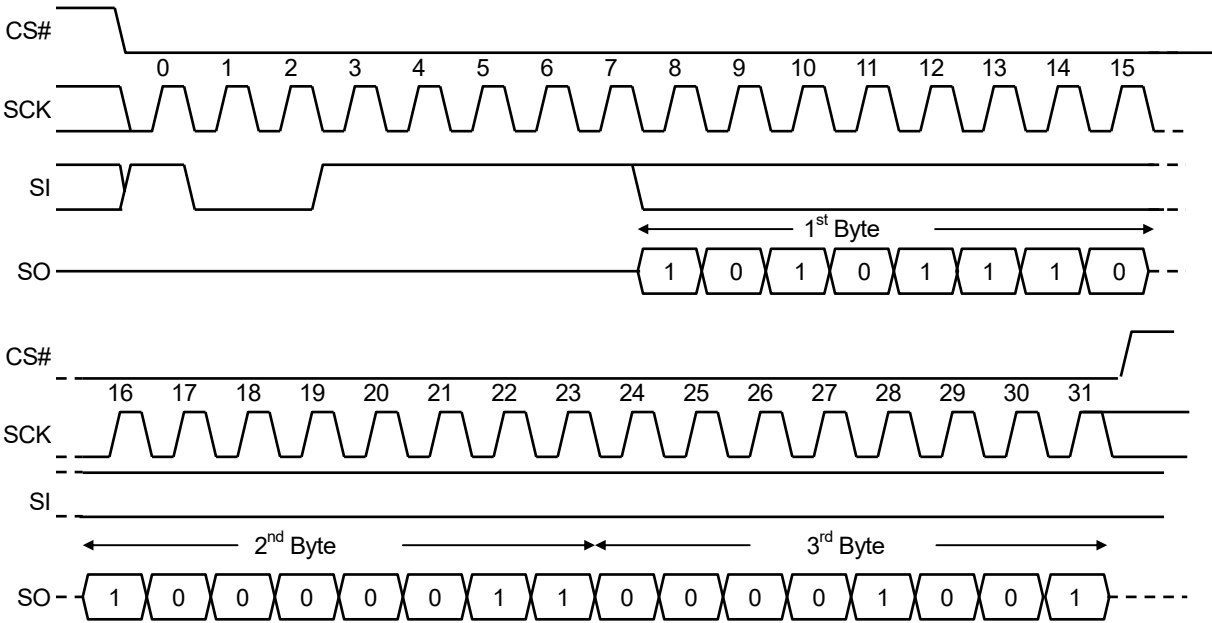

Note : WP# = Fixed "H"

WRITE PROTECTION

Writing protection block is shown as follows: When Status Resister Write Disable(SRWD) bit is reset to “0”, Status Resister number can be changed

Protect Block size

Block Protect BIT		Protected Block	Protected Address Area
BP1	BP0		
0	0	None	None
0	1	Upper 1/4 block	18000h – 1FFFFh
1	0	Upper 1/2 block	10000h – 1FFFFh
1	1	All	00000h – 1FFFFh

Writing Protect

WP#	SRWD	mode	Writing protection status in status register	Protection status in memory	
				Protected blocks	Unprotected blocks
1	0	Software protection (SPM)	Status register is unprotected when WEL-bit is set by WREN command. BP0 and BP1 are unprotected.	Protected	Unprotected
0	0				
1	1				
0	1	Hardware protection (HPM)	Status register is protected. BP0 and BP1 are protected.	Protected	Unprotected

HOLD

Hold status is used for suspending serial communication without disable the chip. SO becomes “High-Z” and SI is “Don’t care” during the hold status. It is necessary to keep CS#=L in hold status.

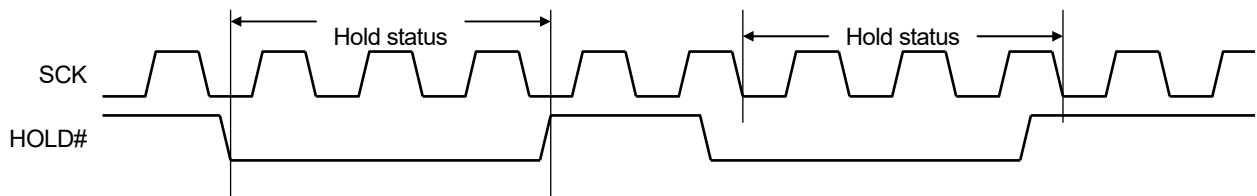

SLEEP

SLEEP command transits MR45V100A to SLEEP Mode, and becomes low current consumption status.

Enter Sleep Mode

- (1) Send SLEEP command “B9h”.
- (2) MR45V100A starts transition to SLEEP mode after rising edge of CS#.

After the command is determined at 7th clock of SCK, SCK and SI input becomes “Don’t care” and transit to SLEEP mode at the rising edge of CS#.

While CS# keeping “High” level, MR45V100A maintains SLEEP mode.

Exit Sleep Mode

- (1) When CS# falling to Low level, MR45V100A start returning SLEEP Mode.
- (2) When the time of tREC being after CS# falling, the return operation from SLEEP mode is finished and command can be input.

And, before the time of tREC, the confirmation of returning is possible by doing dummy read.

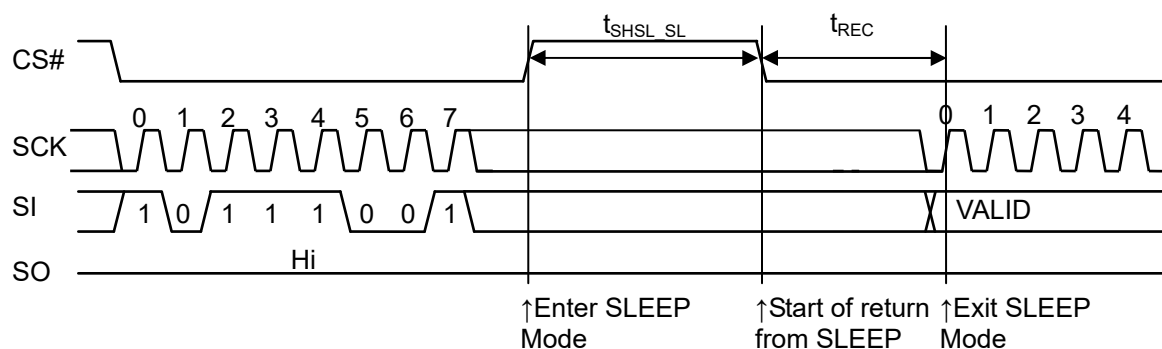

ELECTRICAL CHARACTERISTICS**ABSOLUTE MAXIMUM RATINGS**

The application of stress (voltage, current, or temperature) that exceeds the absolute maximum rating may damage the device. Therefore, do not allow actual characteristics to exceed any one parameter ratings

PIN VOLTAGES

Parameter	Symbol	Rating		Unit
		Min.	Max.	
Pin Voltage (Input Signal)	V_{IN}	-0.5	$V_{CC} + 0.5$	V
Pin Voltage (Input/Output Voltage)	V_{INQ}, V_{OUTQ}	-0.5	$V_{CC} + 0.5$	V
Power Supply Voltage	V_{CC}	-0.5	4.0	V

TEMPERATURE RANGE

Parameter	Symbol	Rating		Unit	Note
		Min.	Max.		
Storage Temperature	Tstg	-55	125	°C	
Operating Temperature	Topr	-40	85	°C	

OTHERS

Parameter	Symbol	Rating	Note
Power Dissipation	P_D	1,000mW	Ta=25°C

RECOMMENDED OPERATING CONDITIONS**POWER SUPPLY VOLTAGE**

Parameter	Symbol	Min.	Typ.	Max.	Unit
Power Supply Voltage	V_{CC}	1.8	3.3	3.6	V
Ground Voltage	V_{SS}	0	0	0	V

DC INPUT VOLTAGE

Parameter	Symbol	Min.	Max.	Unit
Input High Voltage	V_{IH}	$V_{CC} \times 0.7$	$V_{CC}+0.3$	V
Input Low Voltage	V_{IL}	-0.3	$V_{CC} \times 0.3$	V

OVERSHOOT/UNDERSHOOT TOLERANCE (Input signal)

Parameter	Symbol	Pulse Width	Peak
"H" input	V_{IH} OVERSHOOT	$\leq 20\text{ns}$	$V_{CC}+1.0\text{V}$
"L" input	V_{IL} UNDERSHOOT	$\leq 20\text{ns}$	- 1.0V

DC CHARACTERISTICS

DC INPUT/OUTPUT CHARACTERISTICS

Parameter	Symbol	Condition	Min.	Max.	Unit	Note
Output High Voltage	V_{OH}	$I_{OH} = -2\text{mA}$	$V_{CC} \times 0.85$	—	V	
Output Low Voltage	V_{OL}	$I_{OL} = 2\text{mA}$	—	$V_{CC} \times 0.15$	V	
Input Leakage Current	I_{LI}	—	-10	10	μA	
Output Leakage Current	I_{LO}	—	-10	10	μA	

POWER SUPPLY CURRENT

 $V_{CC} = \text{Max. to Min.}, T_a = T_{opr}$

Parameter	Symbol	Condition	Min.	Typ.	Max.	Unit	Note
Power Supply Current (Standby)	I_{CCS}	CS# = V_{CC} , Other input terminals: $V_{IN} = 0\text{V}$ or V_{CC}	—	10	50	μA	1
Power Supply Current (Sleep)	I_{ZZ}	CS# = V_{CC} , Other input terminals : $V_{IN} = 0\text{V}$ or V_{CC}	—	0.1	2	μA	1
Power Supply Current (Operating)	I_{CCA}	SCK = 40MHz, $I_{OUT} = 0\text{mA}$	—	3	4.5	mA	1

Note: 1. Average electric current.

AC CHARACTERISTICS

SPI mode AC characteristics

 V_{CC} =Max. to Min., T_a =Topr.

Parameter	Symbol	Read Cycle		Except for READ		Unit	Note
		Min.	Max.	Min.	Max.		
Clock frequency	f_C	D.C.	34	D.C.	40	MHz	
CS# setup time	t_{SLCH}	10	—	10	—	ns	
CS# De-select time	t_{SHSL}	10	—	10	—	ns	
CS# De-select time (SLEEP)	t_{SHSL_SL}	300	—	300	—	ns	
CS# active hold time	t_{CHSH}	10	—	10	—	ns	
SCK High time	t_{CH}	13	—	11	—	ns	1
SCK Low time	t_{CL}	13	—	11	—	ns	1
Data Setup time	t_{DVCH}	5	—	5	—	ns	
Data Hold time	t_{CHDX}	5	—	5	—	ns	
SCK Low Hold time after HOLD# inactive	t_{HHCH}	10	—	10	—	ns	
SCK Low Hold time after HOLD# active	t_{HLCH}	10	—	10	—	ns	
SCK High Setup time before HOLD# active	t_{CHHL}	10	—	10	—	ns	
SCK High Setup time before HOLD# inactive	t_{CHHH}	10	—	10	—	ns	
Output disable time	t_{SHQZ}	—	12	—	12	ns	2
SCK Low to Output Valid time	t_{CLQV}	—	12	—	9	ns	$V_{CC} \geq 2.7V$
		—	13	—	10	ns	$V_{CC} < 2.7V$
Output Hold time	t_{CLQX}	0	—	0	—	ns	
Input rise time	t_{RI}	—	50	—	50	ns	2
Input fall time	t_{FI}	—	50	—	50	ns	2
HOLD# High to Output Low impedance time	t_{HHQX}	—	20	—	20	ns	2
HOLD# High to Output High impedance time	t_{HLQZ}	—	20	—	20	ns	2
Recovery time from SLEEP mode	t_{REC}	—	100	—	100	μs	

Note: 1. $t_{CH} + t_{CL} \geq 1/f_C$
 2. sample value

TIMING DIAGRAMS

SERIAL INPUT TIMING

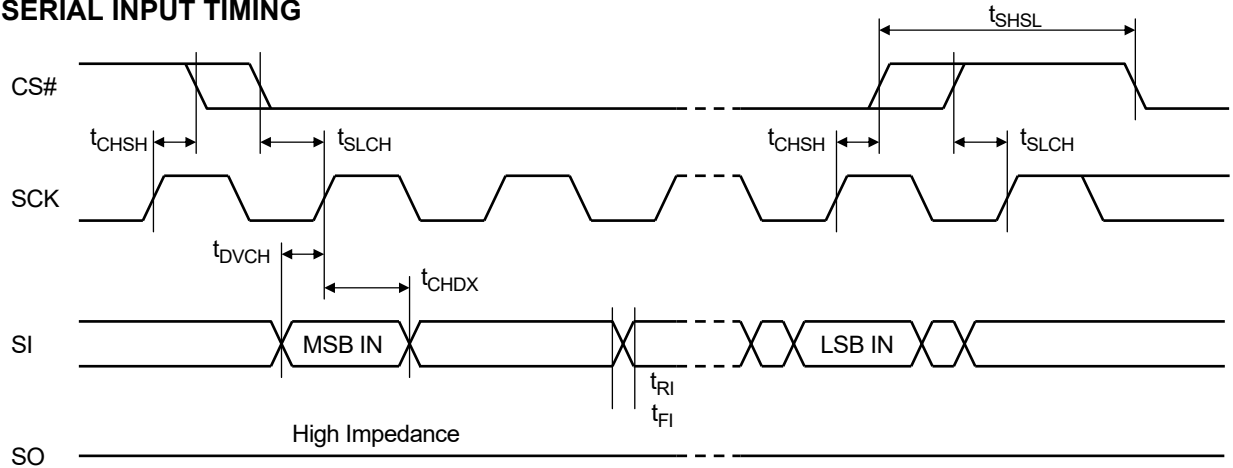

HOLD TIMING

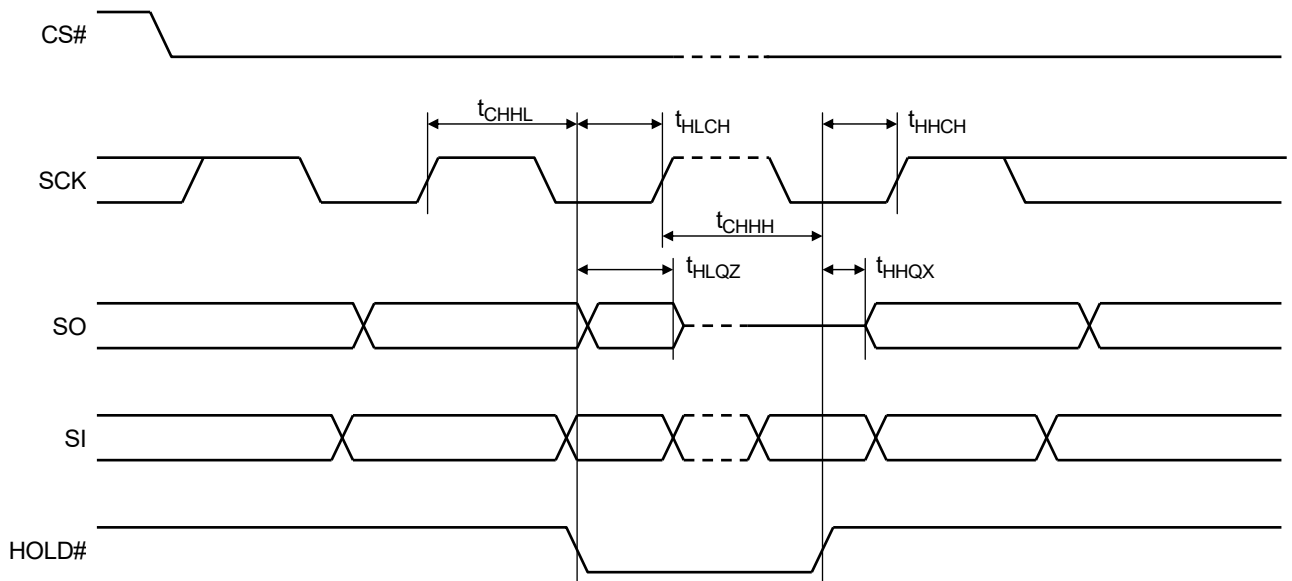

OUTPUT TIMING

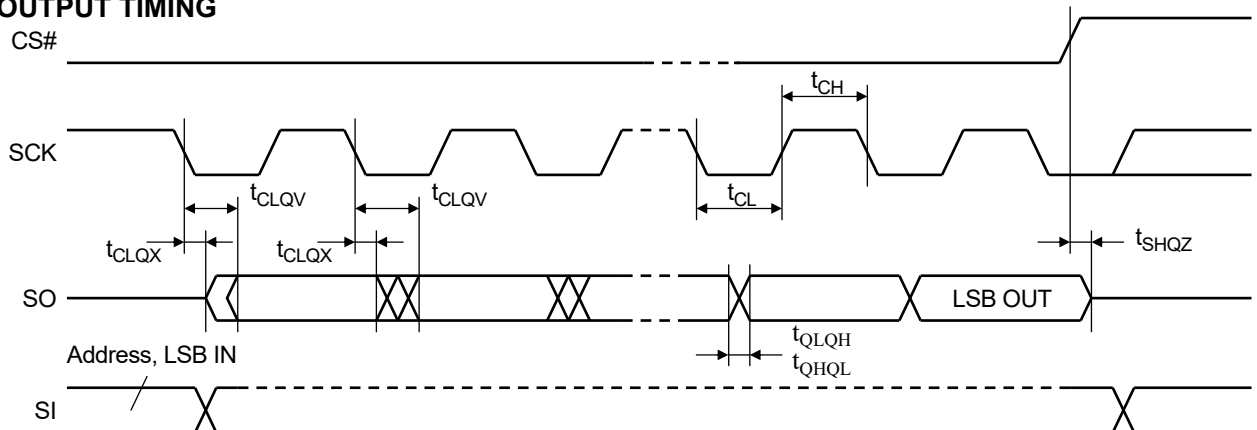

POWER-ON and POWER-OFF CHARACTERISTICS

(Under recommended operating conditions)

Parameter	Symbol	Min.	Max.	Unit	Note
Power-On CS# High Hold Time	t_{VHEL}	100	—	ns	1, 2
Power-Off CS# High Hold Time	t_{EHVL}	0	—	ns	1
Power-On Interval Time	t_{VLVH}	0	—	μ s	2
Power-On time	t_R	30	—	μ s/V	
Power-Off time	t_F	30	—	μ s/V	

Notes:

1. To prevent an erroneous operation, be sure to maintain CS#="H", and set the FeRAM in an inactive state (standby mode) before and after power-on and power-off.
2. Powering on at the intermediate voltage level will cause an erroneous operation; thus, be sure to power up from 0 V.
3. Enter all signals at the same time as power-on or enter all signals after power-on.

Power-On and Power-Off Sequences

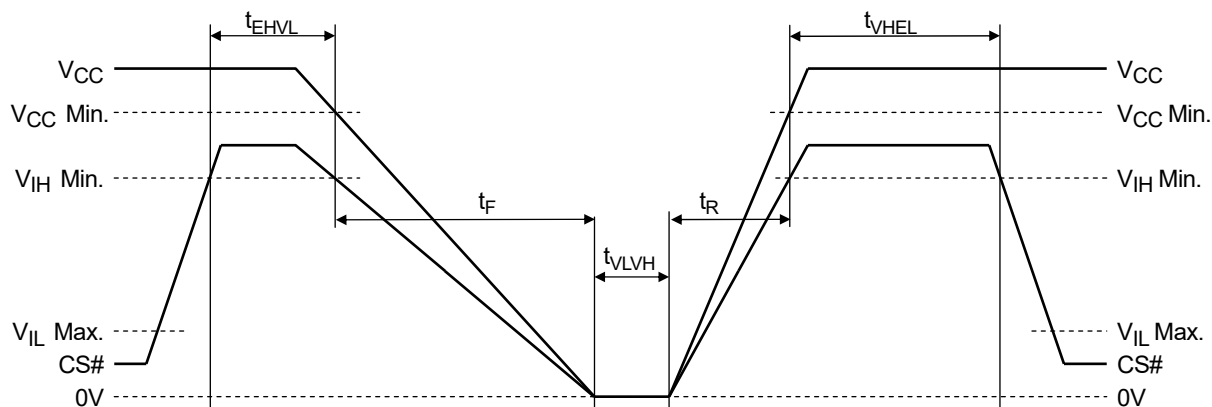

READ/WRITE CYCLES and DATA RETENTION

(Under recommended operating conditions)

Parameter	Min.	Max.	Unit	Note
Read/Write Cycle	10 ¹³	—	Cycle	1
Data Retention	10	—	Year	

Note: 1. Total power on time ≤ 10 years

CAPACITANCE $V_{CC} = 3.3V$, $V_{IN} = V_{OUT} = GND$, $f = 1MHz$, and $T_a = 25^{\circ}C$

Signal	Symbol	Min.	Max.	Unit	Note
Input Capacitance	C_{IN}	—	10	pF	1
Input/Output Capacitance	C_{OUT}	—	10	pF	1

Note:

1. Sampling value.

ORDERING INFORMATION

Product No.	Package Type (Package Code)	Packing	Temp. Range
MR45V100ARAZAARL	8-pin plastic DIP (P-DIP8-300-2.54-T6)	Plastic Tube	-40 to 85°C
MR45V100AMAZAATL	8-pin plastic SOP (P-SOP8-200-1.27-T2K)	Tape and Reel	-40 to 85°C

PACKAGE DIMENSIONS

●8-pin plastic DIP

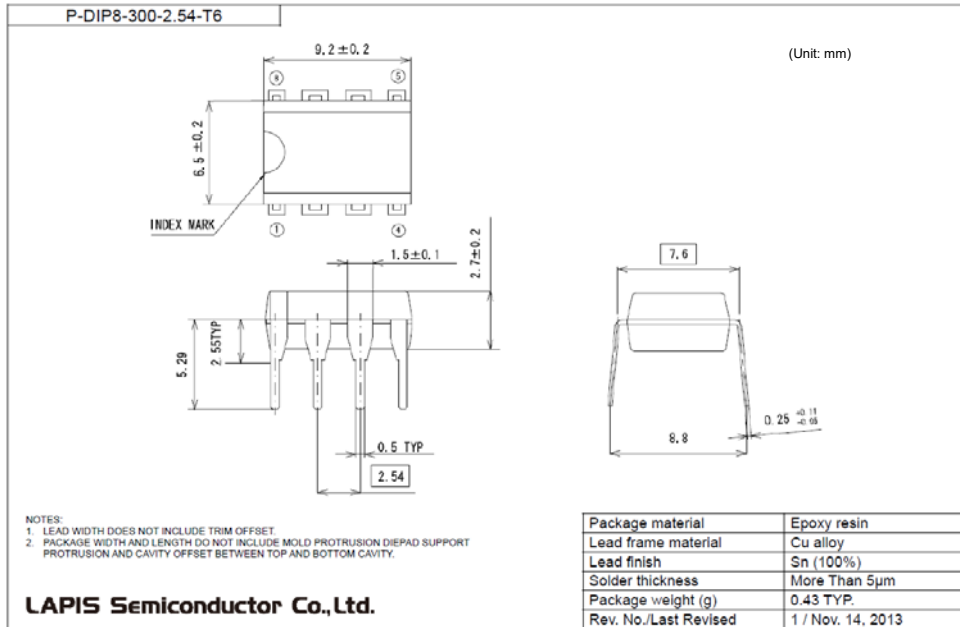

●8-pin plastic SOP

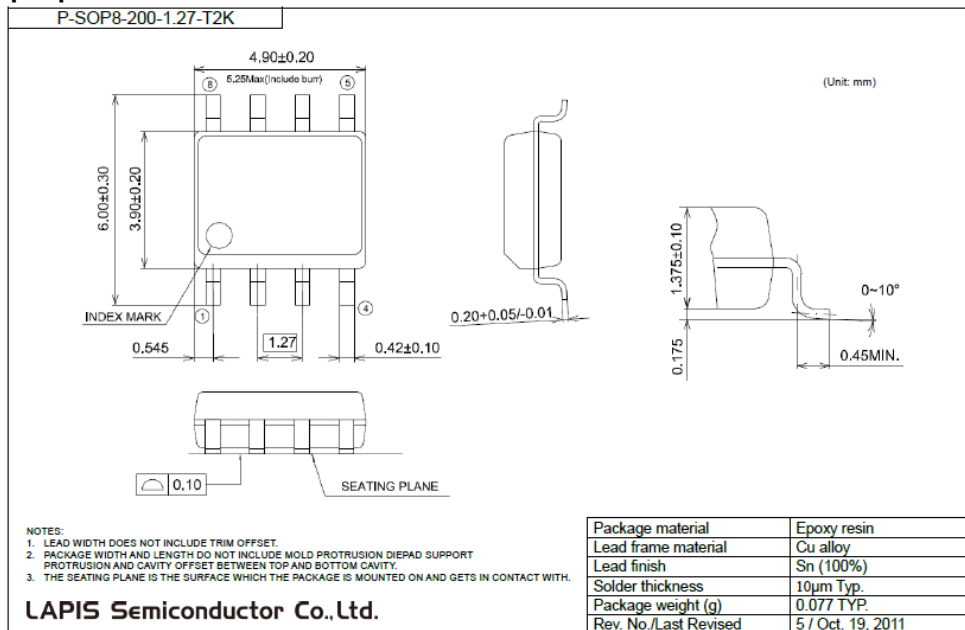

Notes for Mounting the Surface Mount Type Package

The surface mount type packages are very susceptible to heat in reflow mounting and humidity absorbed in storage. Therefore, before you perform reflow mounting, contact a ROHM sales office for the product name, package name, pin number, package code and desired mounting conditions (reflow method, temperature and times).

Revision History

Document No.	Date	Page		Description
		Previous Edition	Current Edition	
FEDR45V100A-01	Sep. 04, 2017	–	–	Final edition 1
FEDR45V100A-02	Oct. 09, 2018	1 3 9 1, 18 18 –	1 3 9 1, 18 18 19	Added Product No. of each package type Added a reset condition of WEL. Moved RDID to page 9 Changed Read/write tolerance : 10^{12} cycles → 10^{13} cycles Added Note1 Added ordering information

Notes

- 1) The information contained herein is subject to change without notice.
- 2) Although LAPIS Semiconductor is continuously working to improve product reliability and quality, semiconductors can break down and malfunction due to various factors. Therefore, in order to prevent personal injury or fire arising from failure, please take safety measures such as complying with the derating characteristics, implementing redundant and fire prevention designs, and utilizing backups and fail-safe procedures. LAPIS Semiconductor shall have no responsibility for any damages arising out of the use of our Products beyond the rating specified by LAPIS Semiconductor.
- 3) Examples of application circuits, circuit constants and any other information contained herein are provided only to illustrate the standard usage and operations of the Products. The peripheral conditions must be taken into account when designing circuits for mass production.
- 4) The technical information specified herein is intended only to show the typical functions of the Products and examples of application circuits for the Products. No license, expressly or implied, is granted hereby under any intellectual property rights or other rights of LAPIS Semiconductor or any third party with respect to the information contained in this document; therefore LAPIS Semiconductor shall have no responsibility whatsoever for any dispute, concerning such rights owned by third parties, arising out of the use of such technical information.
- 5) The Products are intended for use in general electronic equipment (i.e. AV/OA devices, communication, consumer systems, gaming/entertainment sets) as well as the applications indicated in this document.
- 6) The Products specified in this document are not designed to be radiation tolerant.
- 7) For use of our Products in applications requiring a high degree of reliability (as exemplified below), please contact and consult with a LAPIS Semiconductor representative: transportation equipment (i.e. cars, ships, trains), primary communication equipment, traffic lights, fire/crime prevention, safety equipment, medical systems, servers, solar cells, and power transmission systems.
- 8) Do not use our Products in applications requiring extremely high reliability, such as aerospace equipment, nuclear power control systems, and submarine repeaters.
- 9) LAPIS Semiconductor shall have no responsibility for any damages or injury arising from non-compliance with the recommended usage conditions and specifications contained herein.
- 10) LAPIS Semiconductor has used reasonable care to ensure the accuracy of the information contained in this document. However, LAPIS Semiconductor does not warrant that such information is error-free and LAPIS Semiconductor shall have no responsibility for any damages arising from any inaccuracy or misprint of such information.
- 11) Please use the Products in accordance with any applicable environmental laws and regulations, such as the RoHS Directive. For more details, including RoHS compatibility, please contact a ROHM sales office. LAPIS Semiconductor shall have no responsibility for any damages or losses resulting non-compliance with any applicable laws or regulations.
- 12) When providing our Products and technologies contained in this document to other countries, you must abide by the procedures and provisions stipulated in all applicable export laws and regulations, including without limitation the US Export Administration Regulations and the Foreign Exchange and Foreign Trade Act.
- 13) This document, in part or in whole, may not be reprinted or reproduced without prior consent of LAPIS Semiconductor.

Copyright 2017 – 2018 LAPIS Semiconductor Co., Ltd.

LAPIS Semiconductor Co.,Ltd.

2-4-8 Shinyokohama, Kouhoku-ku,
Yokohama 222-8575, Japan
<http://www.lapis-semi.com/en/>