

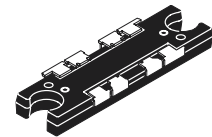
The RF MOSFET Line  
**RF Power Field Effect Transistors**  
N-Channel Enhancement-Mode Lateral MOSFETs

**MRF1570T1**  
**MRF1570FT1**

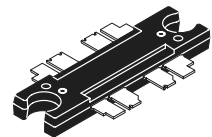
Designed for broadband commercial and industrial applications with frequencies up to 470 MHz. The high gain and broadband performance of these devices make them ideal for large-signal, common source amplifier applications in 12.5 volt mobile FM equipment.

- Specified Performance @ 470 MHz, 12.5 Volts
  - Output Power — 70 Watts
  - Power Gain — 10 dB
  - Efficiency — 50%
- Capable of Handling 20:1 VSWR, @ 15.6 Vdc, 470 MHz, 2 dB Overdrive
- Excellent Thermal Stability
- Characterized with Series Equivalent Large-Signal Impedance Parameters
- Broadband-Full Power Across the Band: 135-175 MHz  
400-470 MHz
- Broadband Demonstration Amplifier Information Available Upon Request
- Available in Tape and Reel. T1 Suffix = 500 Units per 44 mm, 13 inch Reel.

**470 MHz, 70 W, 12.5 V**  
**LATERAL N-CHANNEL**  
**BROADBAND**  
**RF POWER MOSFETs**



**CASE 1366-03, STYLE 1**  
**TO-272 SPLIT LEAD**  
**PLASTIC**  
**MRF1570T1**



**CASE 1366A-02, STYLE 1**  
**TO-272 STRAIGHT LEAD**  
**PLASTIC**  
**MRF1570FT1**

**MAXIMUM RATINGS**

Rating	Symbol	Value	Unit
Drain-Source Voltage	$V_{DSS}$	40	Vdc
Gate-Source Voltage	$V_{GS}$	$\pm 20$	Vdc
Total Device Dissipation @ $T_C = 25^\circ\text{C}$ Derate above $25^\circ\text{C}$	$P_D$	165 0.5	Watts W/ $^\circ\text{C}$
Storage Temperature Range	$T_{stg}$	- 65 to +150	$^\circ\text{C}$
Operating Junction Temperature	$T_J$	175	$^\circ\text{C}$

**ESD PROTECTION CHARACTERISTICS**

Test Conditions	Class
Human Body Model	1 (Minimum)
Machine Model	M2 (Minimum)
Charge Device Model	C2 (Minimum)

**THERMAL CHARACTERISTICS**

Characteristic	Symbol	Max	Unit
Thermal Resistance, Junction to Case	$R_{\theta JC}$	0.75	$^\circ\text{C}/\text{W}$

NOTE – **CAUTION** – MOS devices are susceptible to damage from electrostatic charge. Reasonable precautions in handling and packaging MOS devices should be observed.

**ELECTRICAL CHARACTERISTICS** ( $T_C = 25^\circ\text{C}$  unless otherwise noted)

Characteristic	Symbol	Min	Typ	Max	Unit
----------------	--------	-----	-----	-----	------

**OFF CHARACTERISTICS**

Zero Gate Voltage Drain Current ( $V_{DS} = 60\text{ Vdc}$ , $V_{GS} = 0\text{ Vdc}$ )	$I_{DSS}$	—	—	1	$\mu\text{A}$
---	-----------	---	---	---	---------------

**ON CHARACTERISTICS**

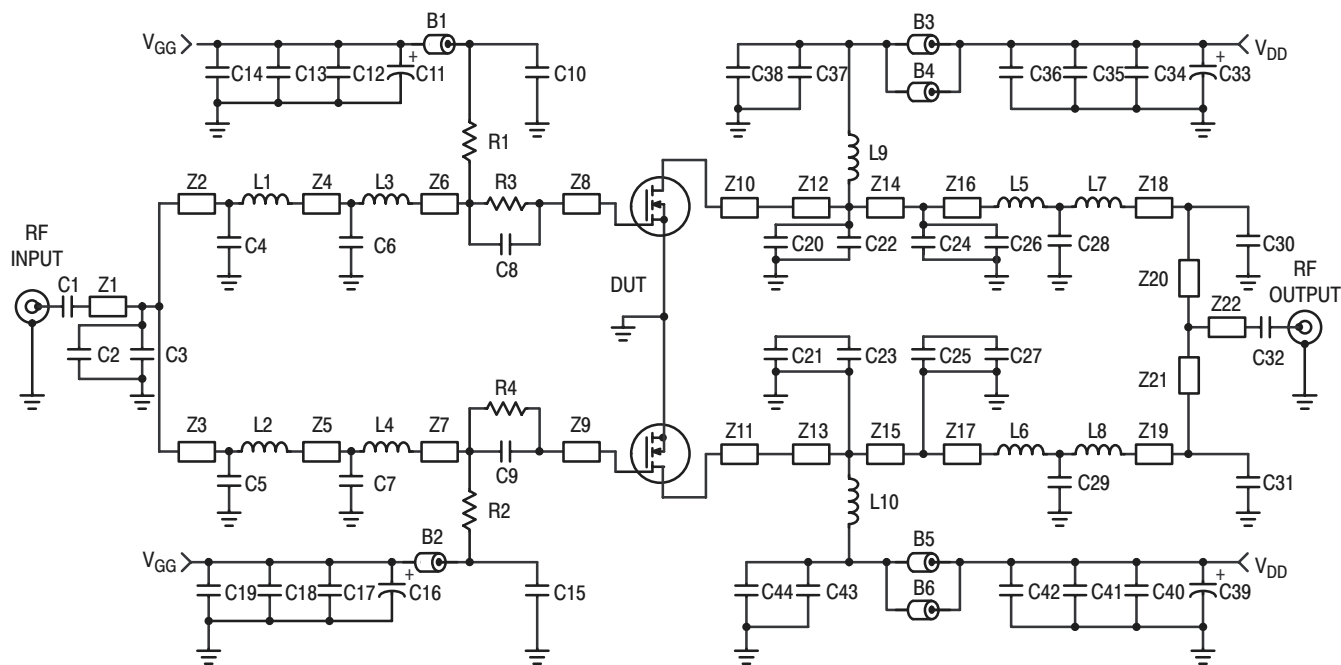
Gate Threshold Voltage ( $V_{DS} = 12.5\text{ Vdc}$ , $I_D = 0.8\text{ mAdc}$ )	$V_{GS(th)}$	1.0	—	3	Vdc
Drain–Source On–Voltage ( $V_{GS} = 10\text{ Vdc}$ , $I_D = 2.0\text{ Adc}$ )	$V_{DS(on)}$	—	—	1	Vdc

**DYNAMIC CHARACTERISTICS**

Input Capacitance (Includes Input Matching Capacitance) ( $V_{DS} = 12.5\text{ Vdc}$ , $V_{GS} = 0\text{ V}$ , $f = 1\text{ MHz}$ )	$C_{iss}$	—	—	500	pF
Output Capacitance ( $V_{DS} = 12.5\text{ Vdc}$ , $V_{GS} = 0\text{ V}$ , $f = 1\text{ MHz}$ )	$C_{oss}$	—	—	250	pF
Reverse Transfer Capacitance ( $V_{DS} = 12.5\text{ Vdc}$ , $V_{GS} = 0\text{ V}$ , $f = 1\text{ MHz}$ )	$C_{rss}$	—	—	35	pF

**RF CHARACTERISTICS** (In Motorola Test Fixture)

Common–Source Amplifier Power Gain ( $V_{DD} = 12.5\text{ Vdc}$ , $P_{out} = 70\text{ W}$ , $I_{DQ} = 800\text{ mA}$ ) $f = 470\text{ MHz}$	$G_{ps}$	10	—	—	dB
Drain Efficiency ( $V_{DD} = 12.5\text{ Vdc}$ , $P_{out} = 70\text{ W}$ , $I_{DQ} = 800\text{ mA}$ ) $f = 470\text{ MHz}$	$\eta$	50	—	—	%
Load Mismatch ( $V_{DD} = 15.6\text{ Vdc}$ , $f = 470\text{ MHz}$ , 2 dB Input Overdrive, VSWR 20:1 at All Phase Angles)	$\Psi$	No Degradation in Output Power Before and After Test			



B1, B2, B3, B4, B5, B6	Long Ferrite Beads, Fair Rite Products	L3, L4	5 nH, 2 Turn Inductors, Coilcraft
C1, C32, C37, C43	270 pF, 100 mil Chip Capacitors	L5, L6, L7, L8	1 Turn, #18 AWG, 0.33" ID Inductors
C2, C20, C21	33 pF, 100 mil Chip Capacitors	L9, L10	3 Turn, #16 AWG, 0.165" ID Inductors
C3	18 pF, 100 mil Chip Capacitor	N1, N2	Type N Flange Mounts
C4, C5	30 pF, 100 mil Chip Capacitors	R1, R2	25.5 $\Omega$ Chip Resistors (1206)
C6, C7	180 pF, 100 mil Chip Capacitors	R3, R4	9.3 $\Omega$ Chip Resistors (1206)
C8, C9	150 pF, 100 mil Chip Capacitors	Z1	0.32" x 0.080" Microstrip
C10, C15	300 pF, 100 mil Chip Capacitors	Z2, Z3	0.46" x 0.080" Microstrip
C11, C16, C33, C39	10 $\mu$ F, 50 V Electrolytic Capacitors	Z4, Z5	0.34" x 0.080" Microstrip
C12, C17, C34, C40	0.1 $\mu$ F, 100 mil Chip Capacitors	Z6, Z7	0.45" x 0.080" Microstrip
C13, C18, C35, C41	1000 pF, 100 mil Chip Capacitors	Z8, Z9, Z10, Z11	0.28" x 0.240" Microstrip
C14, C19, C36, C42	470 pF, 100 mil Chip Capacitors	Z12, Z13	0.39" x 0.080" Microstrip
C22, C23	110 pF, 100 mil Chip Capacitors	Z14, Z15	0.27" x 0.080" Microstrip
C24, C25	68 pF, 100 mil Chip Capacitors	Z16, Z17	0.25" x 0.080" Microstrip
C26, C27	120 pF, 100 mil Chip Capacitors	Z18, Z19	0.29" x 0.080" Microstrip
C28, C29	24 pF, 100 mil Chip Capacitors	Z20, Z21	0.14" x 0.080" Microstrip
C30, C31	27 pF, 100 mil Chip Capacitors	Z22	0.32" x 0.080" Microstrip
C38, C44	240 pF, 100 mil Chip Capacitors	Board	31 mil Glass Teflon <sup>®</sup>
L1, L2	17.5 nH, 6 Turn Inductors, Coilcraft		

Figure 1. 135 – 175 MHz Broadband Test Circuit Schematic

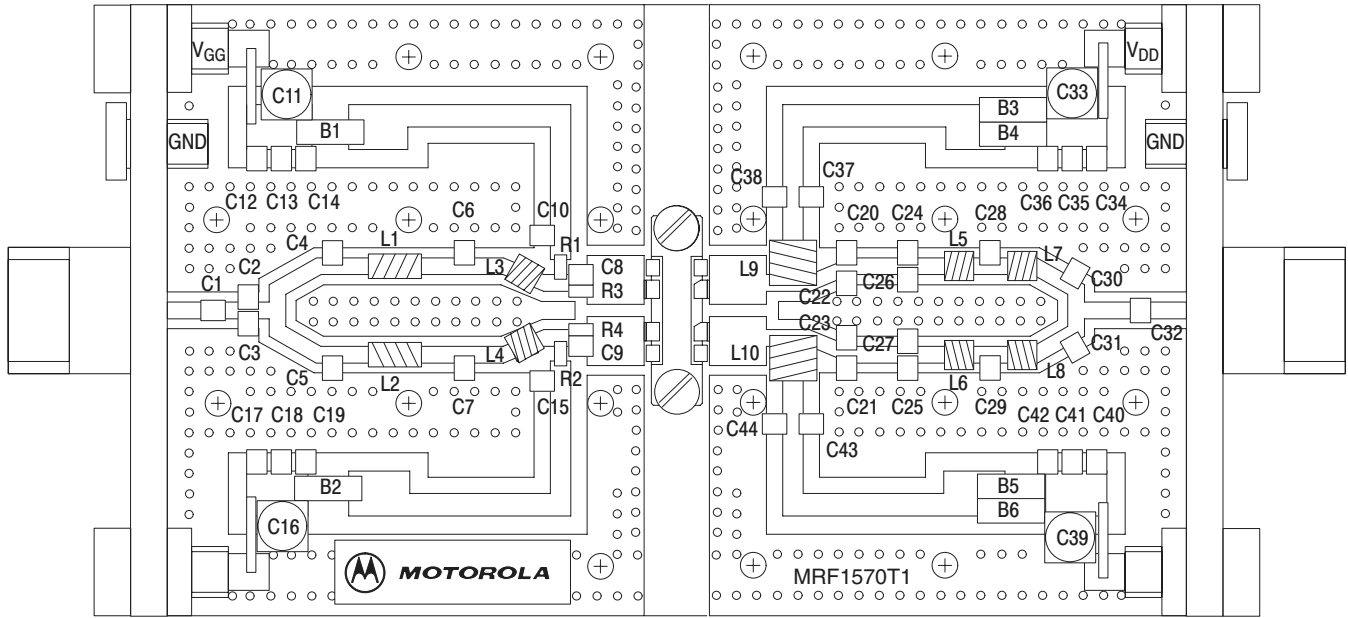


Figure 2. 135 – 175 MHz Broadband Test Circuit Component Layout

TYPICAL CHARACTERISTICS, 135 – 175 MHz

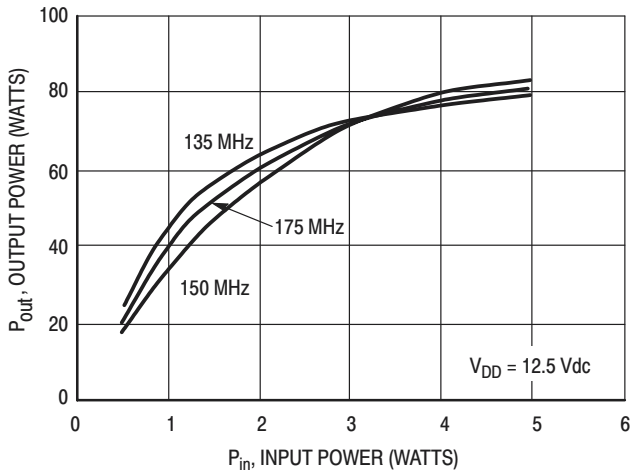


Figure 3. Output Power versus Input Power

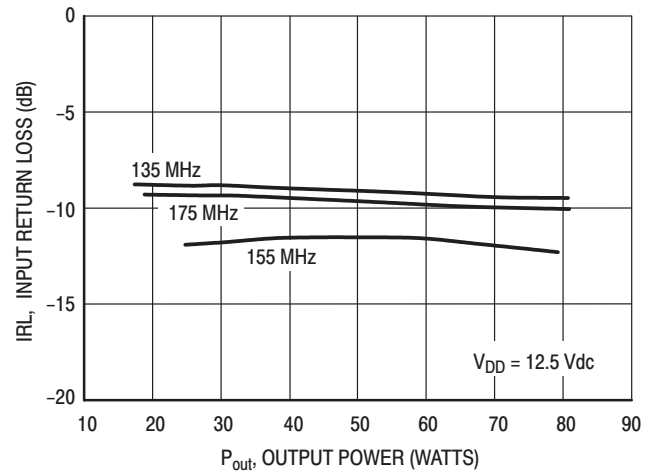
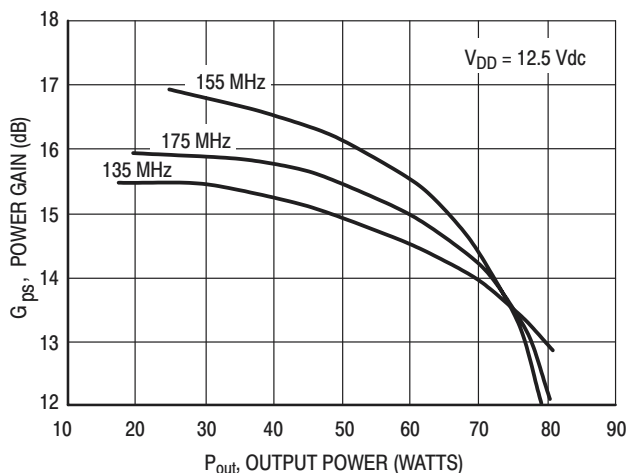
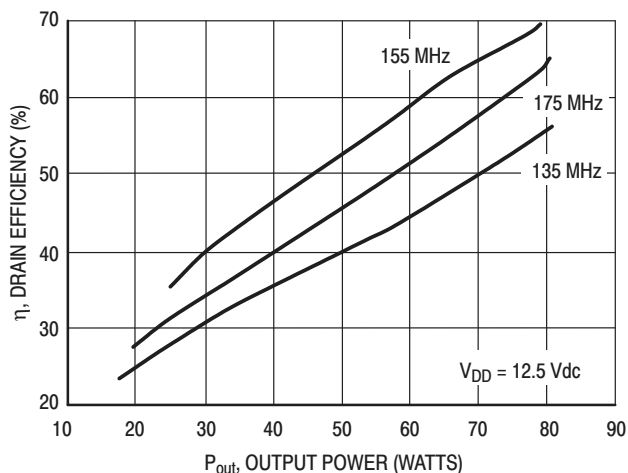


Figure 4. Input Return Loss versus Output Power

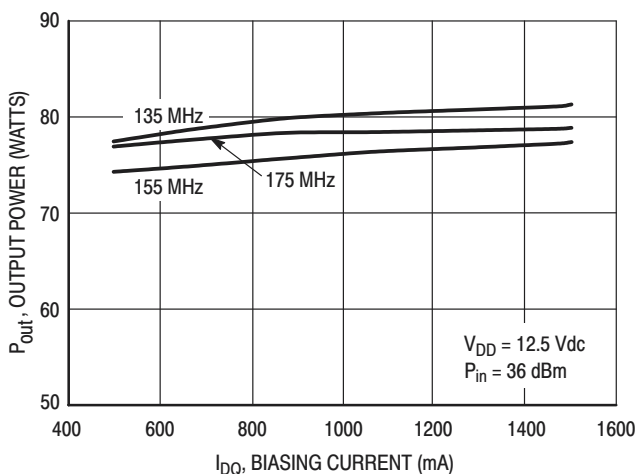
## TYPICAL CHARACTERISTICS, 135 – 175 MHz



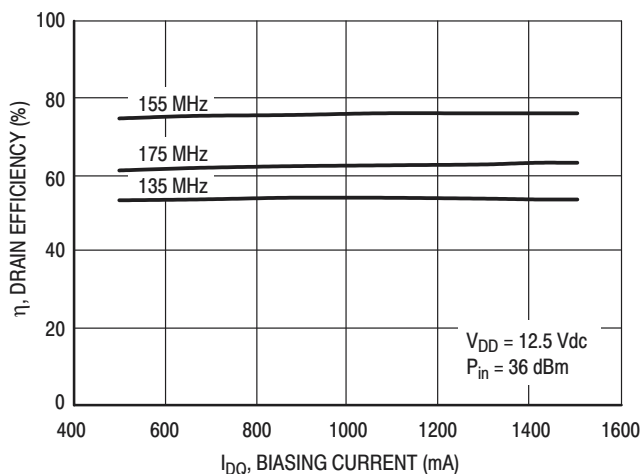
**Figure 5. Gain versus Output Power**



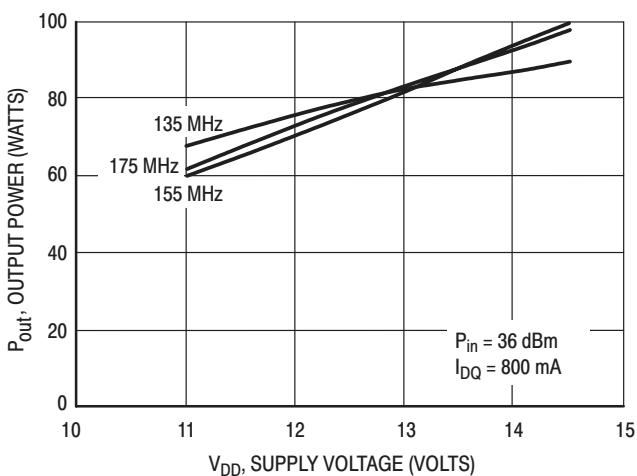
**Figure 6. Drain Efficiency versus Output Power**



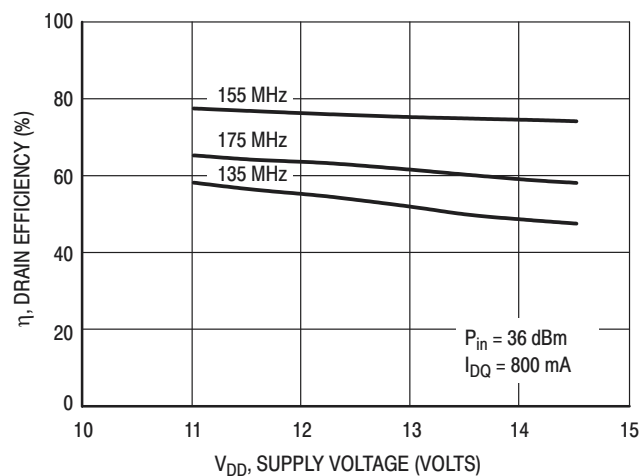
**Figure 7. Output Power versus Biasing Current**



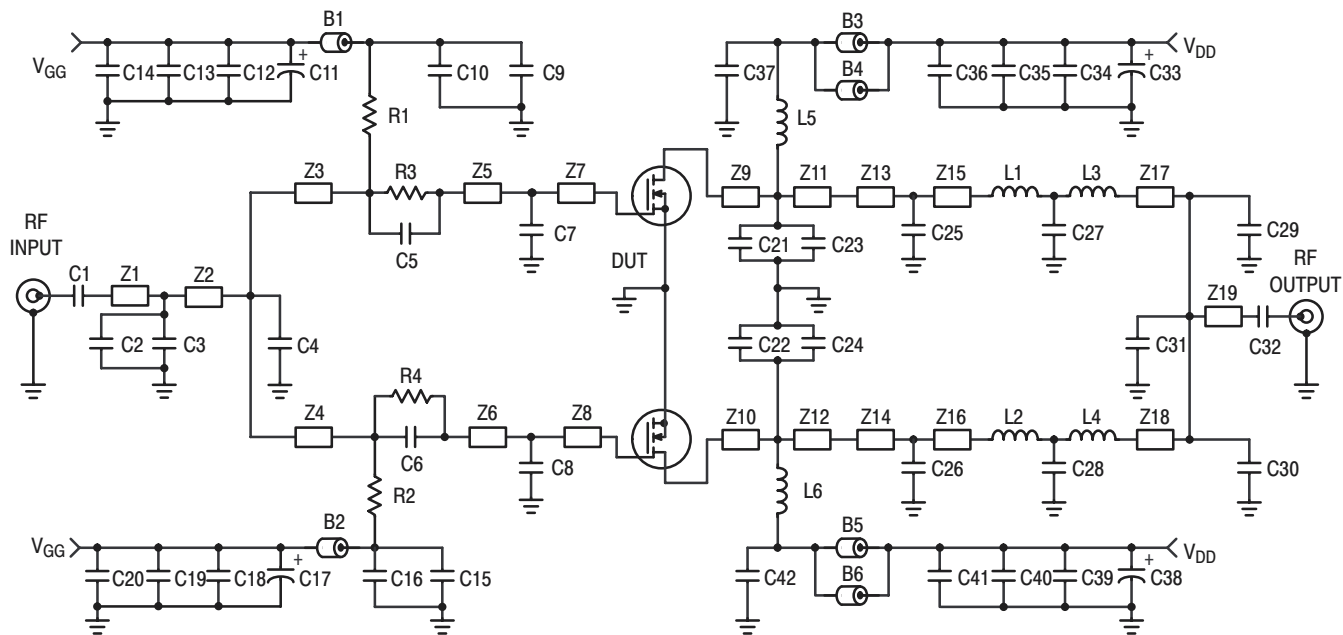
**Figure 8. Drain Efficiency versus Biasing Current**



**Figure 9. Output Power versus Supply Voltage**



**Figure 10. Drain Efficiency versus Supply Voltage**



B1, B2, B3, B4, B5, B6	Long Ferrite Beads, Fair Rite Products	L1, L2, L3, L4	1 Turn, #18 AWG, 0.085" ID Inductors
C1, C9, C15, C32	270 pF, 100 mil Chip Capacitors	L5, L6	2 Turn, #16 AWG, 0.165" ID Inductors
C2, C3	7.5 pF, 100 mil Chip Capacitors	N1, N2	Type N Flange Mounts
C4	5.1 pF, 100 mil Chip Capacitor	R1, R2	25.5 $\Omega$ Chip Resistors (1206)
C5, C6	180 pF, 100 mil Chip Capacitors	R3, R4	10 $\Omega$ Chip Resistors (1206)
C7, C8	47 pF, 100 mil Chip Capacitors	Z1	0.240" x 0.080" Microstrip
C10, C16, C37, C42	120 pF, 100 mil Chip Capacitors	Z2	0.185" x 0.080" Microstrip
C11, C17, C33, C38	10 $\mu$ F, 50 V Electrolytic Capacitors	Z3, Z4	1.500" x 0.080" Microstrip
C12, C18, C34, C39	470 pF, 100 mil Chip Capacitors	Z5, Z6	0.150" x 0.240" Microstrip
C13, C19, C35, C40	1200 pF, 100 mil Chip Capacitors	Z7, Z8	0.140" x 0.240" Microstrip
C14, C20, C36, C41	0.1 $\mu$ F, 100 mil Chip Capacitors	Z9, Z10	0.140" x 0.240" Microstrip
C21, C22	33 pF, 100 mil Chip Capacitors	Z11, Z12	0.150" x 0.240" Microstrip
C23, C24	27 pF, 100 mil Chip Capacitors	Z13, Z14	0.270" x 0.080" Microstrip
C25, C26	15 pF, 100 mil Chip Capacitors	Z15, Z16	0.680" x 0.080" Microstrip
C27, C28	2.2 pF, 100 mil Chip Capacitors	Z17, Z18	0.320" x 0.080" Microstrip
C29, C30	6.2 pF, 100 mil Chip Capacitors	Z19	0.380" x 0.080" Microstrip
C31	1.0 pF, 100 mil Chip Capacitor	Board	31 mil Glass Teflon <sup>®</sup>

Figure 11. 400 – 470 MHz Broadband Test Circuit Schematic

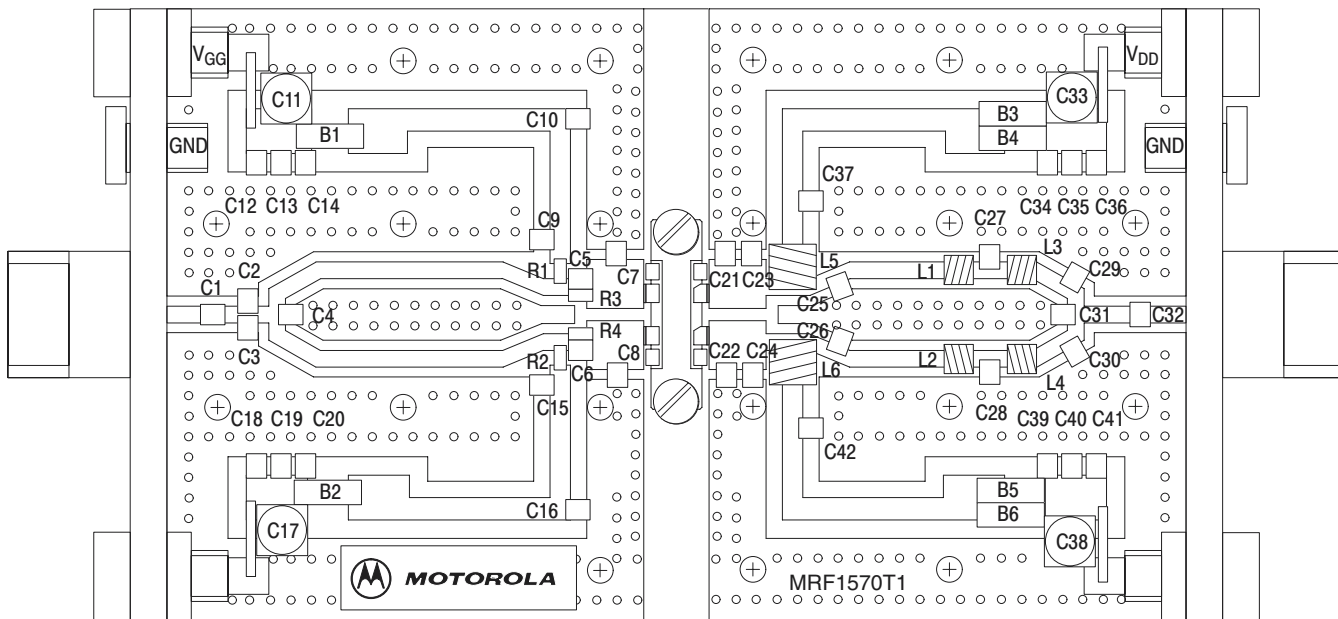


Figure 12. 400 – 470 MHz Broadband Test Circuit Component Layout

TYPICAL CHARACTERISTICS, 400 – 470 MHz

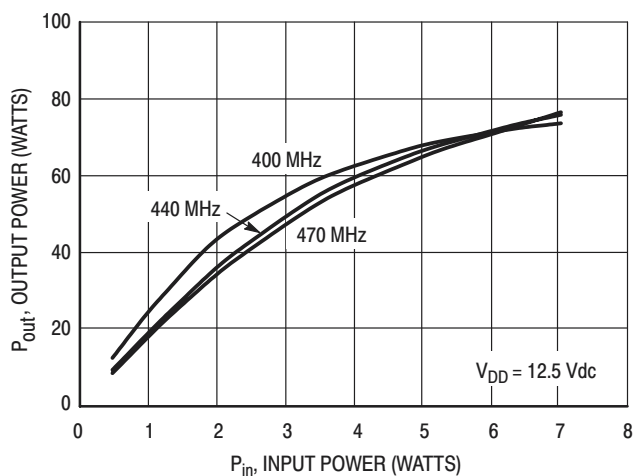


Figure 13. Output Power versus Input Power

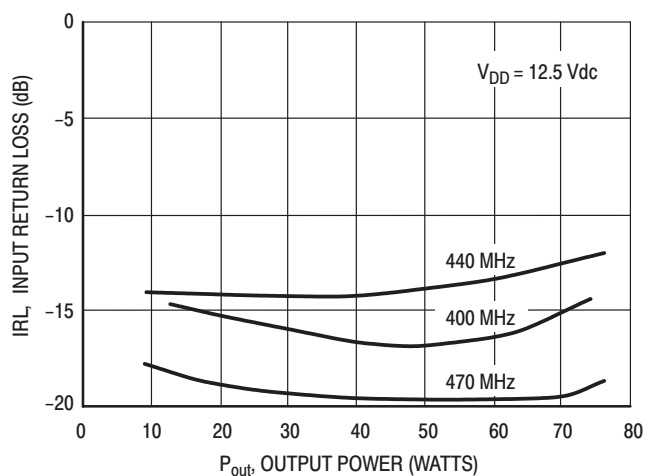
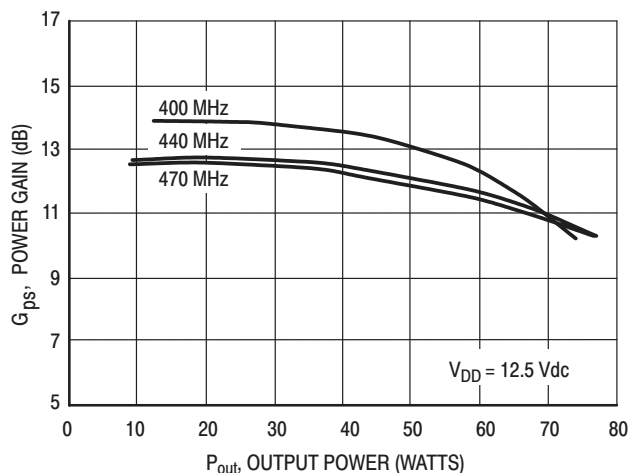
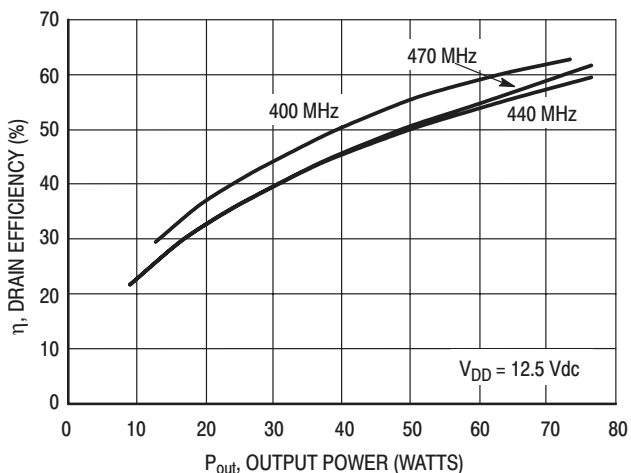


Figure 14. Input Return Loss versus Output Power

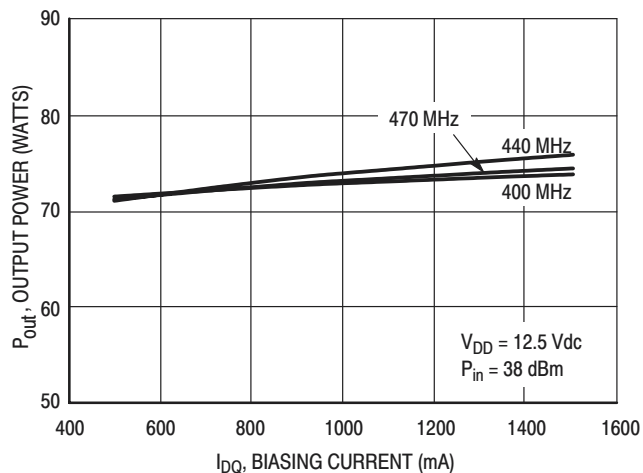
## TYPICAL CHARACTERISTICS, 400 – 470 MHz



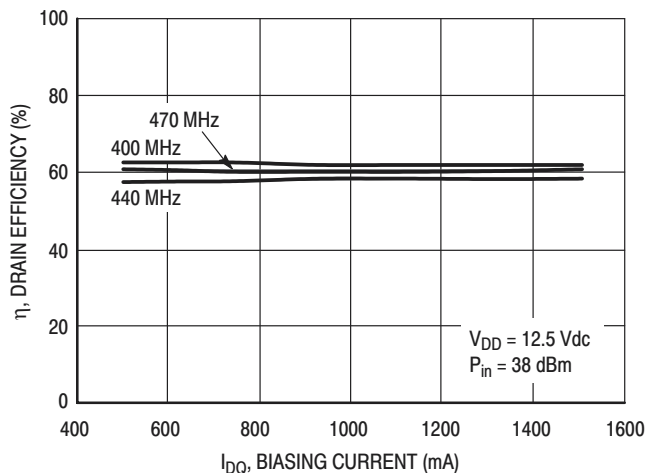
**Figure 15. Gain versus Output Power**



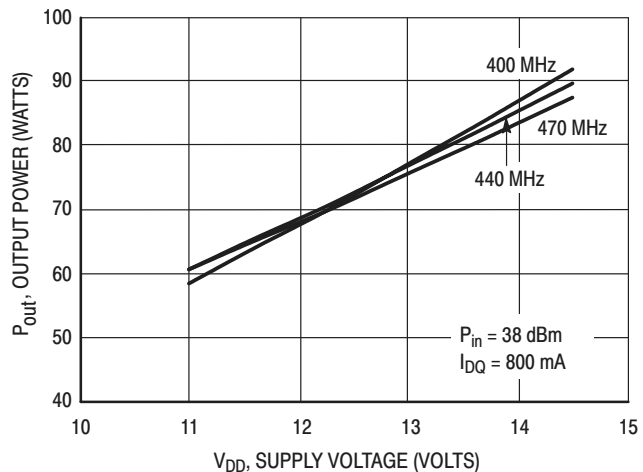
**Figure 16. Drain Efficiency versus Output Power**



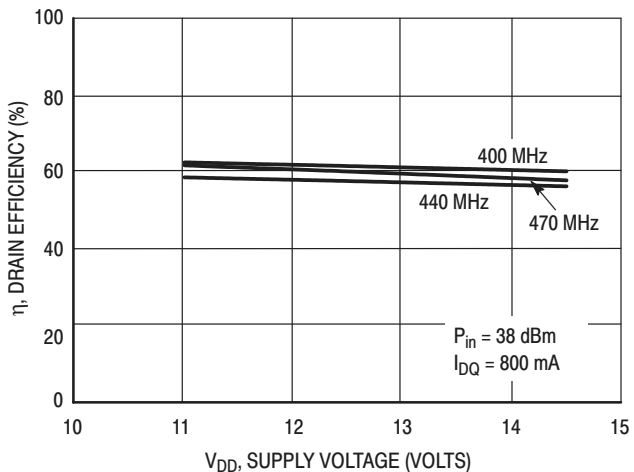
**Figure 17. Output Power versus Biasing Current**



**Figure 18. Drain Efficiency versus Biasing Current**

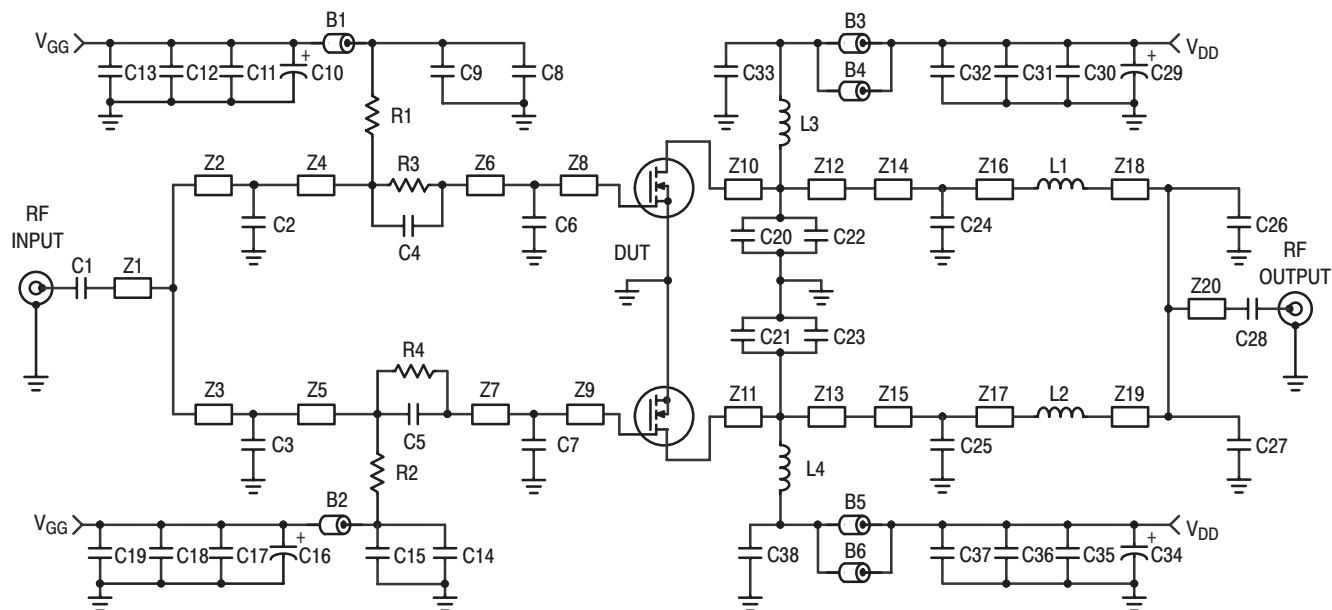


**Figure 19. Output Power versus Supply Voltage**



**Figure 20. Drain Efficiency versus Supply Voltage**





B1, B2, B3, B4, B5, B6	Long Ferrite Beads, Fair Rite Products	N1, N2	Type N Flange Mounts
C1, C8, C14, C28	270 pF, 100 mil Chip Capacitors	R1, R2	1.0 k $\Omega$ Chip Resistors (1206)
C2, C3	10 pF, 100 mil Chip Capacitors	R3, R4	10 $\Omega$ Chip Resistors (1206)
C4, C5	180 pF, 100 mil Chip Capacitors	Z1	0.40" x 0.080" Microstrip
C6, C7	47 pF, 100 mil Chip Capacitors	Z2, Z3	0.26" x 0.080" Microstrip
C9, C15, C33, C38	120 pF, 100 mil Chip Capacitors	Z4, Z5	1.35" x 0.080" Microstrip
C10, C16, C29, C34	10 $\mu$ F, 50 V Electrolytic Capacitors	Z6, Z7	0.17" x 0.240" Microstrip
C11, C17, C30, C35	470 pF, 100 mil Chip Capacitors	Z8, Z9	0.12" x 0.240" Microstrip
C12, C18, C31, C36	1200 pF, 100 mil Chip Capacitors	Z10, Z11	0.14" x 0.240" Microstrip
C13, C19, C32, C37	0.1 $\mu$ F, 100 mil Chip Capacitors	Z12, Z13	0.15" x 0.240" Microstrip
C20, C21	22 pF, 100 mil Chip Capacitors	Z14, Z15	0.18" x 0.172" Microstrip
C22, C23	20 pF, 100 mil Chip Capacitors	Z16, Z17	1.23" x 0.080" Microstrip
C24, C25, C26, C27	5.1 pF, 100 mil Chip Capacitors	Z18, Z19	0.12" x 0.080" Microstrip
L1, L2	1 Turn, #18 AWG, 0.115" ID Inductors	Z20	0.40" x 0.080" Microstrip
L3, L4	2 Turn, #16 AWG, 0.165" ID Inductors	Board	31 mil Glass Teflon <sup>®</sup>

Figure 21. 450 – 520 MHz Broadband Test Circuit Schematic

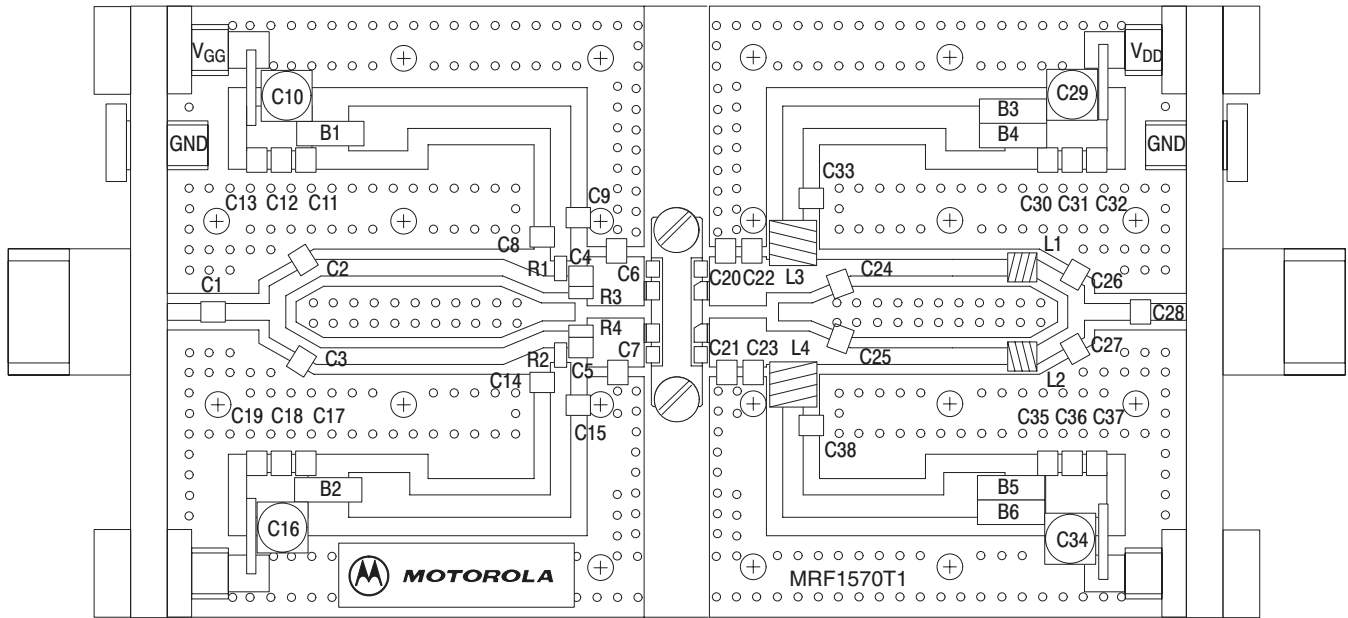


Figure 22. 450 – 520 MHz Broadband Test Circuit Component Layout

TYPICAL CHARACTERISTICS, 450 – 520 MHz

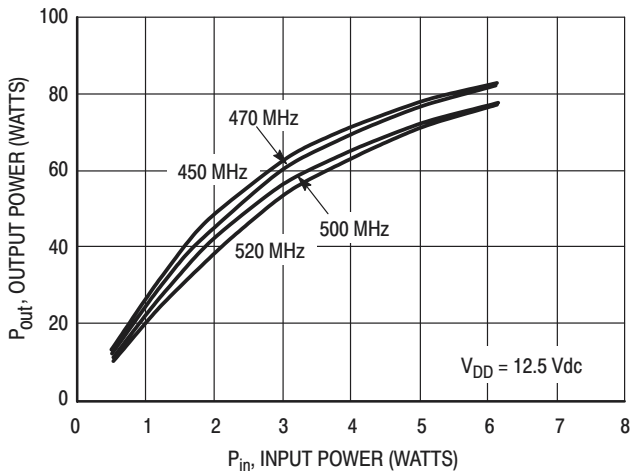


Figure 23. Output Power versus Input Power

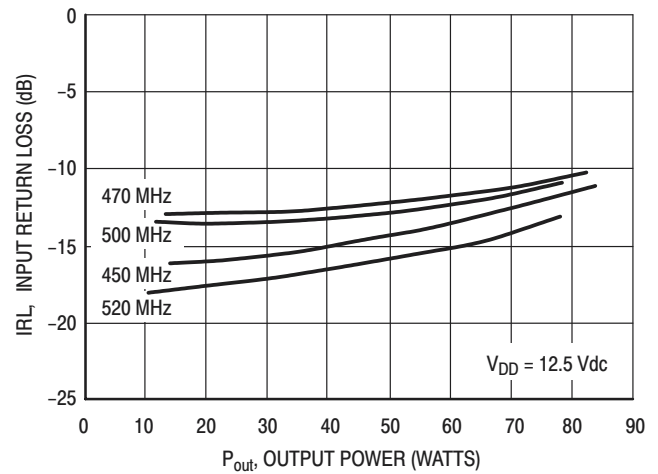
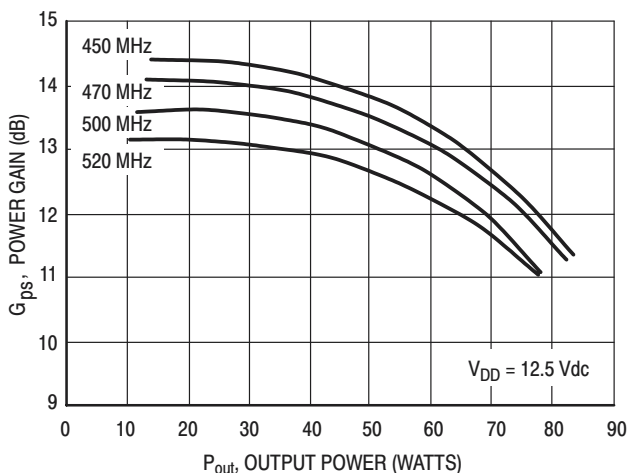
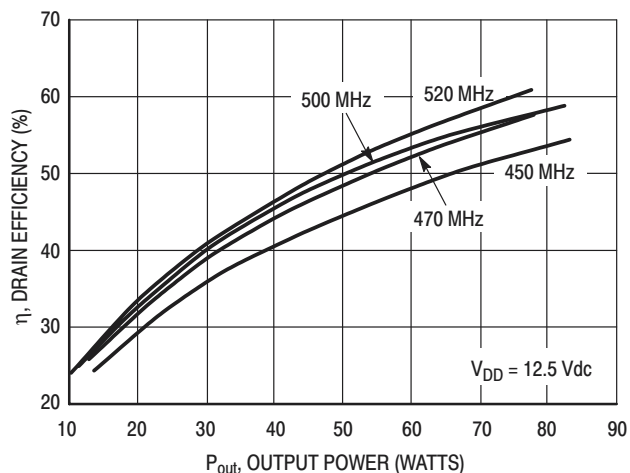


Figure 24. Input Return Loss versus Output Power

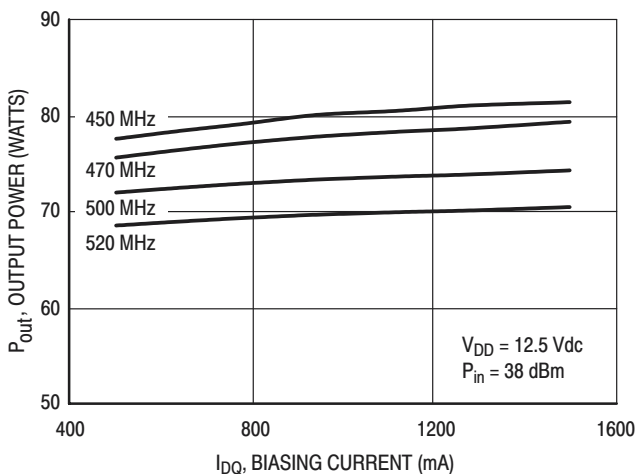
## TYPICAL CHARACTERISTICS, 450 – 520 MHz



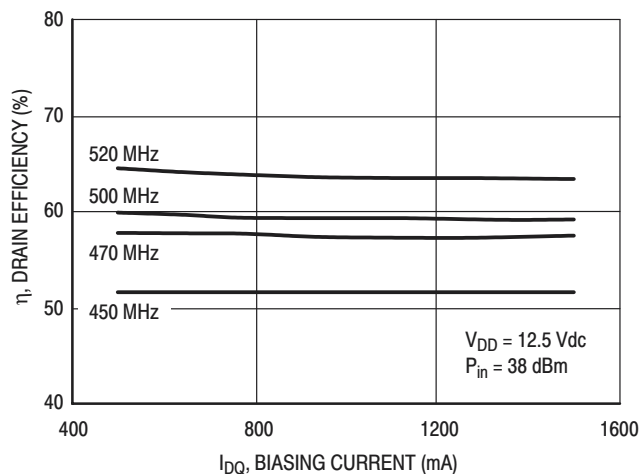
**Figure 25. Gain versus Output Power**



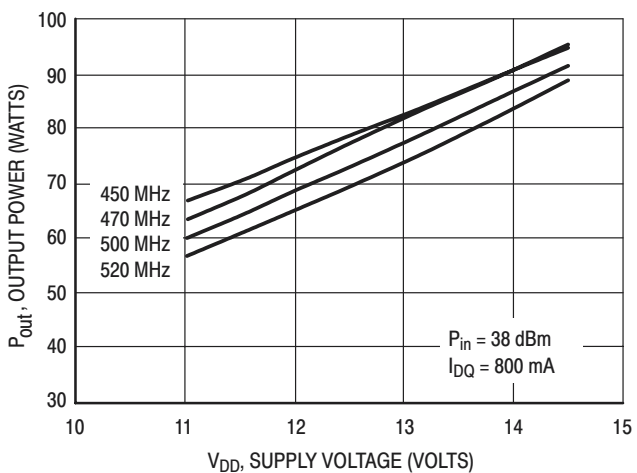
**Figure 26. Drain Efficiency versus Output Power**



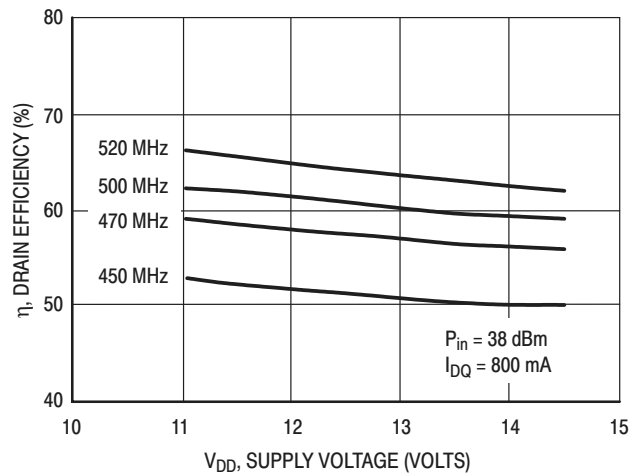
**Figure 27. Output Power versus Biasing Current**



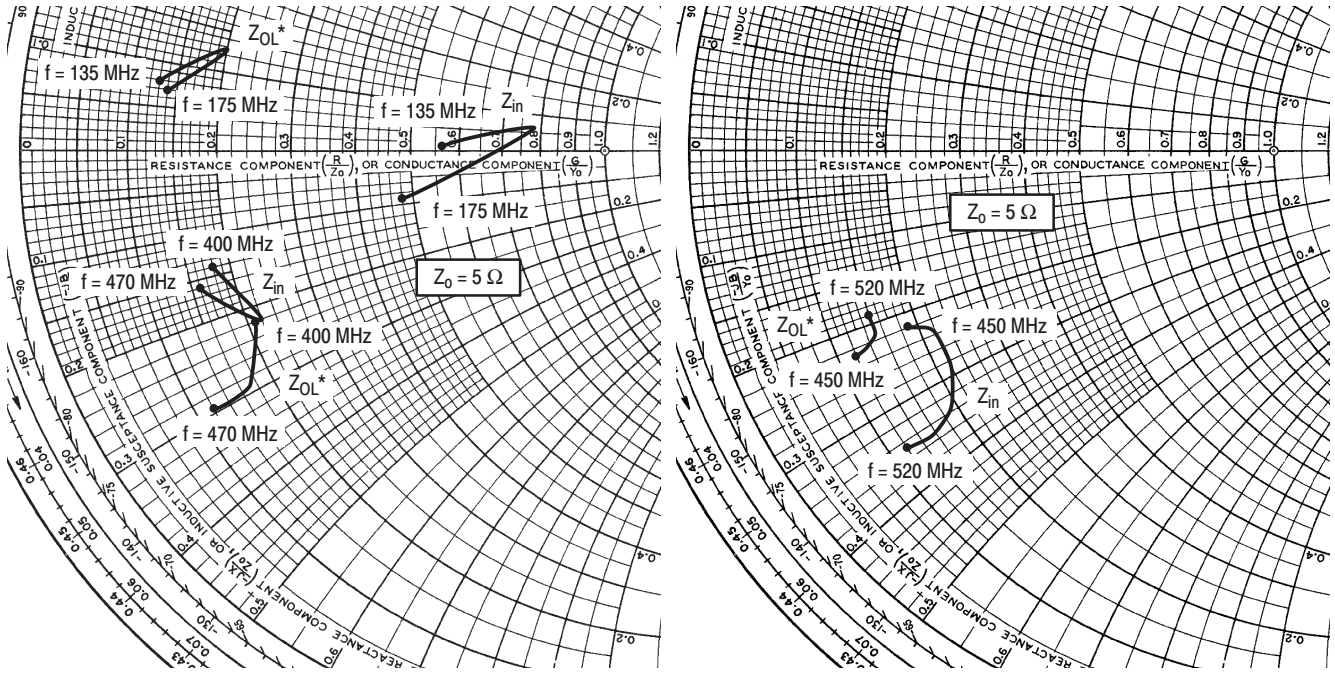
**Figure 28. Drain Efficiency versus Biasing Current**



**Figure 29. Output Power versus Supply Voltage**



**Figure 30. Drain Efficiency versus Supply Voltage**



$V_{DD} = 12.5\text{ V}$ ,  $I_{DQ} = 0.8\text{ A}$ ,  $P_{out} = 70\text{ W}$

f MHz	$Z_{in}$ $\Omega$	$Z_{OL}^*$ $\Omega$
135	$2.8 + j0.05$	$0.65 + j0.42$
155	$3.9 + j0.34$	$1.01 + j0.63$
175	$2.4 - j0.47$	$0.71 + j0.37$

$V_{DD} = 12.5\text{ V}$ ,  $I_{DQ} = 0.8\text{ A}$ ,  $P_{out} = 70\text{ W}$

f MHz	$Z_{in}$ $\Omega$	$Z_{OL}^*$ $\Omega$
400	$0.92 - j0.71$	$1.05 - j1.10$
440	$1.12 - j1.11$	$0.83 - j1.45$
470	$0.82 - j0.79$	$0.59 - j1.43$

$V_{DD} = 12.5\text{ V}$ ,  $I_{DQ} = 0.8\text{ A}$ ,  $P_{out} = 70\text{ W}$

f MHz	$Z_{in}$ $\Omega$	$Z_{OL}^*$ $\Omega$
450	$0.94 - j1.12$	$0.61 - j1.14$
470	$1.03 - j1.17$	$0.62 - j1.12$
500	$0.95 - j1.71$	$0.75 - j1.03$
520	$0.62 - j1.74$	$0.77 - j0.97$

$Z_{in}$  = Complex conjugate of source impedance.

$Z_{OL}^*$  = Complex conjugate of the load impedance at given output power, voltage, frequency, and  $\eta_D > 50\%$ .

Notes: Impedance  $Z_{in}$  was measured with input terminated at  $50\ \Omega$ . Impedance  $Z_{OL}$  was measured with output terminated at  $50\ \Omega$ .

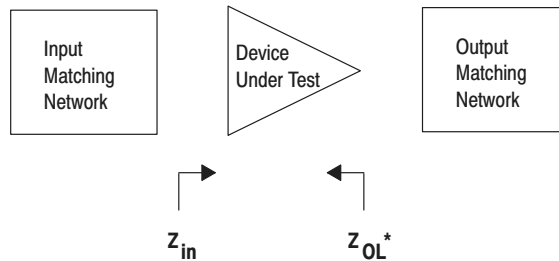


Figure 31. Series Equivalent Input and Output Impedance

## APPLICATIONS INFORMATION

### DESIGN CONSIDERATIONS

This device is a common-source, RF power, N-Channel enhancement mode, Lateral Metal-Oxide Semiconductor Field-Effect Transistor (MOSFET). Motorola Application Note AN211A, "FETs in Theory and Practice", is suggested reading for those not familiar with the construction and characteristics of FETs.

This surface mount packaged device was designed primarily for VHF and UHF mobile power amplifier applications. Manufacturability is improved by utilizing the tape and reel capability for fully automated pick and placement of parts. However, care should be taken in the design process to insure proper heat sinking of the device.

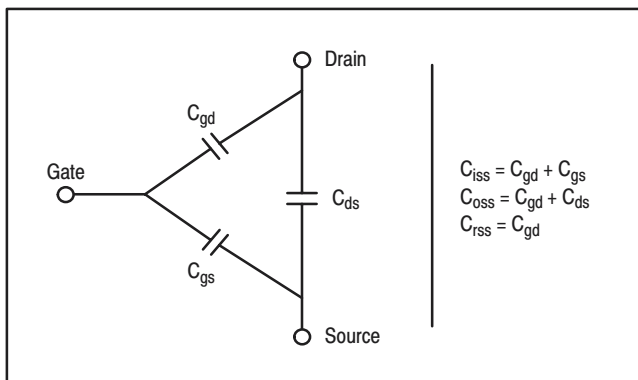
The major advantages of Lateral RF power MOSFETs include high gain, simple bias systems, relative immunity from thermal runaway, and the ability to withstand severely mismatched loads without suffering damage.

### MOSFET CAPACITANCES

The physical structure of a MOSFET results in capacitors between all three terminals. The metal oxide gate structure determines the capacitors from gate-to-drain ( $C_{gd}$ ), and gate-to-source ( $C_{gs}$ ). The PN junction formed during fabrication of the RF MOSFET results in a junction capacitance from drain-to-source ( $C_{ds}$ ). These capacitances are characterized as input ( $C_{iss}$ ), output ( $C_{oss}$ ) and reverse transfer ( $C_{rss}$ ) capacitances on data sheets. The relationships between the inter-terminal capacitances and those given on data sheets are shown below. The  $C_{iss}$  can be specified in two ways:

1. Drain shorted to source and positive voltage at the gate.
2. Positive voltage of the drain in respect to source and zero volts at the gate.

In the latter case, the numbers are lower. However, neither method represents the actual operating conditions in RF applications.



### DRAIN CHARACTERISTICS

One critical figure of merit for a FET is its static resistance in the full-on condition. This on-resistance,  $R_{DS(on)}$ , occurs in the linear region of the output characteristic and is specified at a specific gate-source voltage and drain current. The

drain-source voltage under these conditions is termed  $V_{DS(on)}$ . For MOSFETs,  $V_{DS(on)}$  has a positive temperature coefficient at high temperatures because it contributes to the power dissipation within the device.

$BV_{DSS}$  values for this device are higher than normally required for typical applications. Measurement of  $BV_{DSS}$  is not recommended and may result in possible damage to the device.

### GATE CHARACTERISTICS

The gate of the RF MOSFET is a polysilicon material, and is electrically isolated from the source by a layer of oxide. The DC input resistance is very high – on the order of  $10^9 \Omega$  – resulting in a leakage current of a few nanoamperes.

Gate control is achieved by applying a positive voltage to the gate greater than the gate-to-source threshold voltage,  $V_{GS(th)}$ .

**Gate Voltage Rating** — Never exceed the gate voltage rating. Exceeding the rated  $V_{GS}$  can result in permanent damage to the oxide layer in the gate region.

**Gate Termination** — The gates of these devices are essentially capacitors. Circuits that leave the gate open-circuited or floating should be avoided. These conditions can result in turn-on of the devices due to voltage build-up on the input capacitor due to leakage currents or pickup.

**Gate Protection** — These devices do not have an internal monolithic zener diode from gate-to-source. If gate protection is required, an external zener diode is recommended. Using a resistor to keep the gate-to-source impedance low also helps dampen transients and serves another important function. Voltage transients on the drain can be coupled to the gate through the parasitic gate-drain capacitance. If the gate-to-source impedance and the rate of voltage change on the drain are both high, then the signal coupled to the gate may be large enough to exceed the gate-threshold voltage and turn the device on.

### DC BIAS

Since this device is an enhancement mode FET, drain current flows only when the gate is at a higher potential than the source. RF power FETs operate optimally with a quiescent drain current ( $I_{DQ}$ ), whose value is application dependent. This device was characterized at  $I_{DQ} = 800 \text{ mA}$ , which is the suggested value of bias current for typical applications. For special applications such as linear amplification,  $I_{DQ}$  may have to be selected to optimize the critical parameters.

The gate is a dc open circuit and draws no current. Therefore, the gate bias circuit may generally be just a simple resistive divider network. Some special applications may require a more elaborate bias system.

### GAIN CONTROL

Power output of this device may be controlled to some degree with a low power dc control signal applied to the gate, thus facilitating applications such as manual gain control, ALC/AGC and modulation systems. This characteristic is very dependent on frequency and load line.

## **MOUNTING**

The specified maximum thermal resistance of  $0.75^{\circ}\text{C}/\text{W}$  assumes a majority of the  $0.170'' \times 0.608''$  source contact on the back side of the package is in good contact with an appropriate heat sink. As with all RF power devices, the goal of the thermal design should be to minimize the temperature at the back side of the package. Refer to Motorola Application Note AN4005/D, "Thermal Management and Mounting Method for the PLD-1.5 RF Power Surface Mount Package," and Engineering Bulletin EB209/D, "Mounting Method for RF Power Leadless Surface Mount Transistor" for additional information.

## **AMPLIFIER DESIGN**

Impedance matching networks similar to those used with bipolar transistors are suitable for this device. For examples

see Motorola Application Note AN721, "Impedance Matching Networks Applied to RF Power Transistors." Large-signal impedances are provided, and will yield a good first pass approximation.

Since RF power MOSFETs are triode devices, they are not unilateral. This coupled with the very high gain of this device yields a device capable of self oscillation. Stability may be achieved by techniques such as drain loading, input shunt resistive loading, or output to input feedback. The RF test fixture implements a parallel resistor and capacitor in series with the gate, and has a load line selected for a higher efficiency, lower gain, and more stable operating region. See Motorola Application Note AN215A, "RF Small-Signal Design Using Two-Port Parameters" for a discussion of two port network theory and stability.

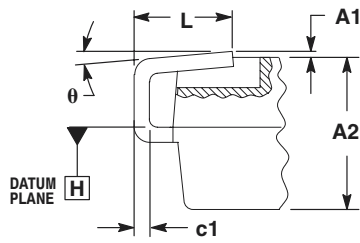
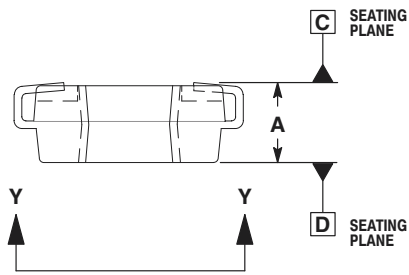
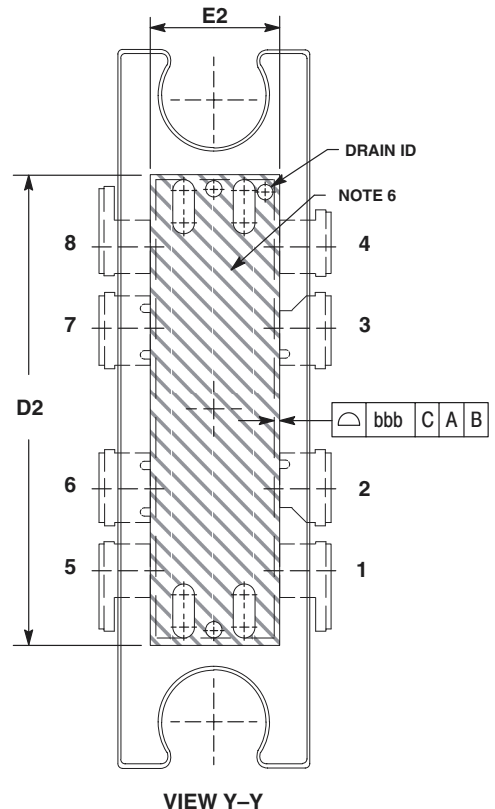
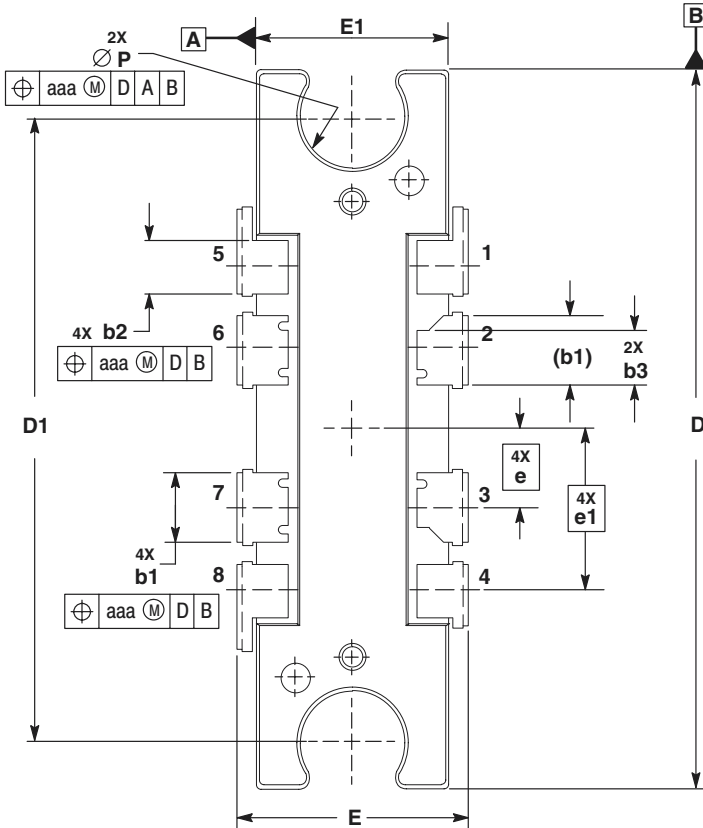
# NOTES

# NOTES



# NOTES

# PACKAGE DIMENSIONS

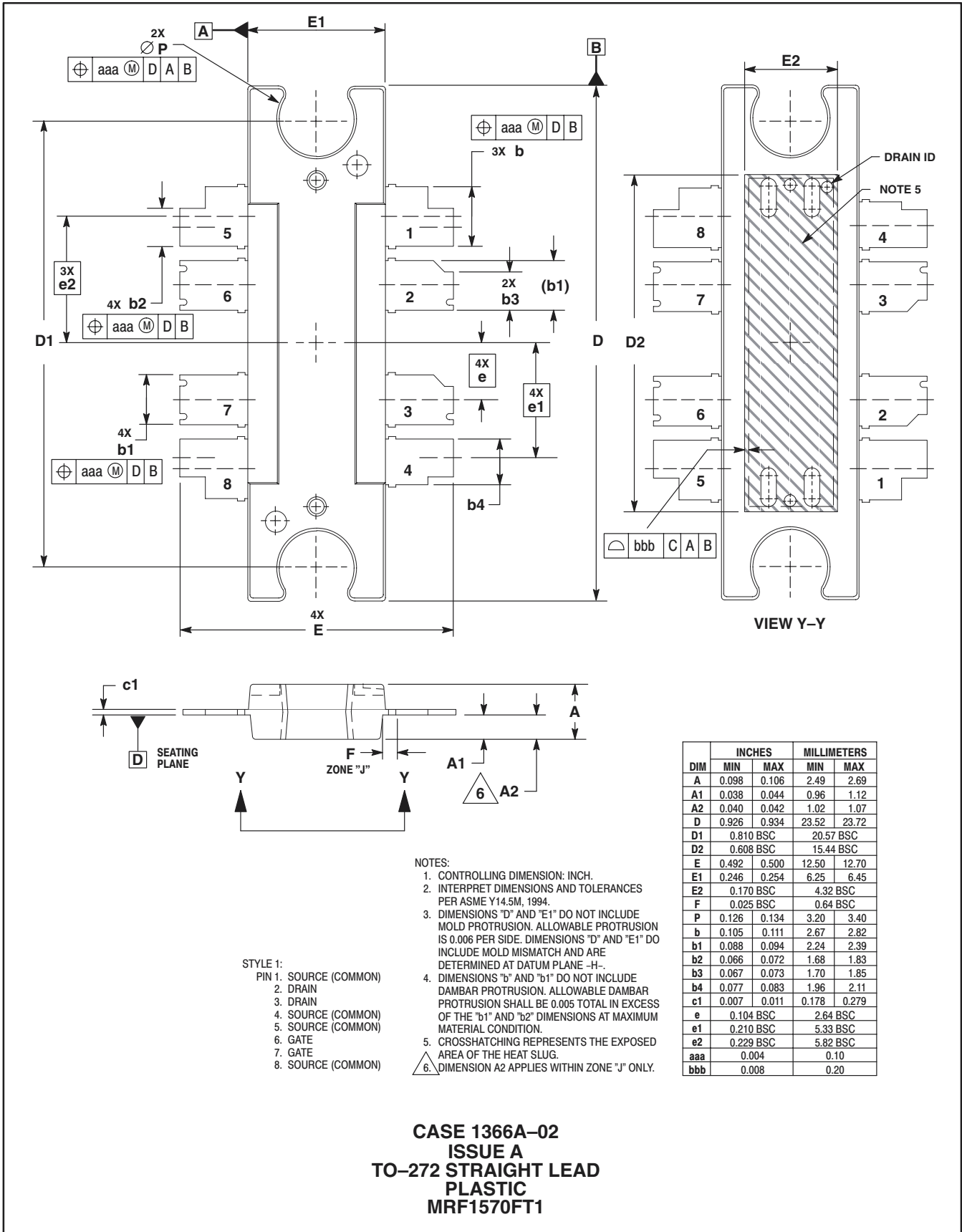


- STYLE 1:  
 PIN 1. SOURCE (COMMON)  
 2. DRAIN  
 3. DRAIN  
 4. SOURCE (COMMON)  
 5. SOURCE (COMMON)  
 6. GATE  
 7. GATE  
 8. SOURCE (COMMON)

**CASE 1366-03  
 ISSUE B  
 TO-272 SPLIT LEAD  
 PLASTIC  
 MRF1570T1**

- NOTES:  
 1. CONTROLLING DIMENSION: INCH.  
 2. INTERPRET DIMENSIONS AND TOLERANCES PER ASME Y14.5M, 1994.  
 3. DATUM PLANE -H- IS LOCATED AT TOP OF LEAD AND IS COINCIDENT WITH THE LEAD WHERE THE LEAD EXITS THE PLASTIC BODY AT THE TOP OF THE PARTING LINE.  
 4. DIMENSION D AND E1 DO NOT INCLUDE MOLD PROTRUSION. ALLOWABLE PROTRUSION IS 0.006 PER SIDE. DIMENSION D AND E1 DO INCLUDE MOLD MISMATCH AND ARE DETERMINED AT DATUM PLANE -H-.  
 5. DIMENSIONS b1 AND b2 DO NOT INCLUDE DAMBAR PROTRUSION. ALLOWABLE DAMBAR PROTRUSION SHALL BE 0.005 TOTAL IN EXCESS OF THE b1 AND b2 DIMENSIONS AT MAXIMUM MATERIAL CONDITION.  
 6. CROSSHATCHING REPRESENTS THE EXPOSED AREA OF THE HEAT SLUG.

DIM	INCHES		MILLIMETERS	
	MIN	MAX	MIN	MAX
A	0.098	0.110	2.49	2.79
A1	0.000	0.004	0.00	0.10
A2	0.098	0.106	2.49	2.69
D	0.926	0.934	23.52	23.72
D1	0.810 BSC		20.57 BSC	
D2	0.608 BSC		15.44 BSC	
E	0.296	0.304	7.52	7.72
E1	0.246	0.254	6.25	6.45
E2	0.170 BSC		4.32 BSC	
L	0.060	0.070	1.52	1.78
P	0.126	0.134	3.20	3.40
b1	0.088	0.094	2.24	2.39
b2	0.066	0.072	1.68	1.83
b3	0.067	0.073	1.70	1.85
c1	0.007	0.011	0.178	0.279
e	0.104 BSC		2.64 BSC	
e1	0.210 BSC		5.33 BSC	
θ	0°	6°	0°	6°
aaa	0.004		0.10	
bbb	0.008		0.20	



**CASE 1366A-02  
ISSUE A  
TO-272 STRAIGHT LEAD  
PLASTIC  
MRF1570FT1**

Motorola reserves the right to make changes without further notice to any products herein. Motorola makes no warranty, representation, or guarantee regarding the suitability of its products for any particular purpose, nor does Motorola assume any liability arising out of the application or use of any product or circuit, and specifically disclaims any and all liability, including without limitation consequential or incidental damages. "Typical" parameters can and do vary in different applications and actual performance may vary over time. All operating parameters, including "Typicals", must be validated for each customer application by customer's technical experts. Motorola does not convey any license under its patent rights nor the rights of others. Motorola products are not designed, intended, or authorized for use as components in systems intended for surgical implant into the body, or other applications intended to support or sustain life, or for any other application in which the failure of the Motorola product could create a situation where personal injury or death may occur. Should Buyer purchase or use Motorola products for any such unintended or unauthorized application, Buyer shall indemnify and hold Motorola and its officers, employees, subsidiaries, affiliates, and distributors harmless against all claims, costs, damages, and expenses, and reasonable attorney fees arising out of, directly or indirectly, any claim of personal injury or death associated with such unintended or unauthorized use, even if such claim alleges that Motorola was negligent regarding the design or manufacture of the part. Motorola and the Stylized M Logo are registered trademarks of Motorola, Inc. Motorola, Inc. is an Equal Opportunity/Affirmative Action Employer.

Motorola and the Stylized M Logo are registered in the US Patent & Trademark Office. All other product or service names are the property of their respective owners.

© Motorola, Inc. 2002.

**How to reach us:**

**USA/EUROPE/Locations Not Listed:** Motorola Literature Distribution; P.O. Box 5405, Denver, Colorado 80217. 1-303-675-2140 or 1-800-441-2447

**JAPAN:** Motorola Japan Ltd.; SPS, Technical Information Center, 3-20-1, Minami-Azabu. Minato-ku, Tokyo 106-8573 Japan. 81-3-3440-3569

**ASIA/PACIFIC:** Motorola Semiconductors H.K. Ltd.; Silicon Harbour Centre, 2 Dai King Street, Tai Po Industrial Estate, Tai Po, N.T. Hong Kong. 852-26668334

**Technical Information Center:** 1-800-521-6274

**HOME PAGE:** <http://www.motorola.com/semiconductors>



**MOTOROLA**



**MRF1570T1/D**