

The MRFIC Line

1.9 GHz GaAs Power Amplifier

This two-stage class AB monolithic GaAs amplifier in a low-cost 16 lead plastic package is designed for output or driver applications in 1.9 GHz PCS handsets and basestations. The design is optimized for 3.0 Volt operation in systems such as Japan's PHS, Europe's DECT and the emerging North American PCS services. With modifications to the simple off-chip matching, the device can be used in other applications from 1.5 to 2.5 GHz.

- High Output Capability = 27 dBm Typical P_{sat}
21.5 dBm Typical with PHS Format
- High Gain = 21 dB Typical Small Signal, 20 dB at $P_{out} = 22$ dBm
- Low Current Drain = 170 mA Typical with PHS Format
250 mA Typical with DECT Format
- Low-Cost, Low Profile Plastic TSSOP Package
- Order MRFIC1805R2 for Tape and Reel.
R2 Suffix = 2,500 Units per 16 mm, 13 inch Reel.
- Device Marking = M1805

MRFIC1805

**1.9 GHz
POWER AMPLIFIER
GaAs MONOLITHIC
INTEGRATED CIRCUIT**

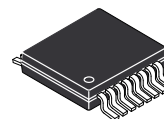

**CASE 948C-03
(TSSOP-16)**

ABSOLUTE MAXIMUM RATINGS ($T_A = 25^\circ\text{C}$ unless otherwise noted)

Ratings	Symbol	Value	Unit
Supply Voltage	V_{DD}, V_{D1}, V_{D2}	6	Vdc
Supply Voltage	V_{SS}	-4	Vdc
RF Input Power	RF_{in}	+10	dBm
Drain Current	I_{DD}	500	mA
Thermal Resistance, Junction to Air	$R_{\theta JA}$	240	/W
Operating Junction Temperature	T_J	+175	$^\circ\text{C}$
Ambient Operating Temperature	T_A	-30 to +85	$^\circ\text{C}$
Storage Temperature	T_{stg}	-65 to +125	$^\circ\text{C}$

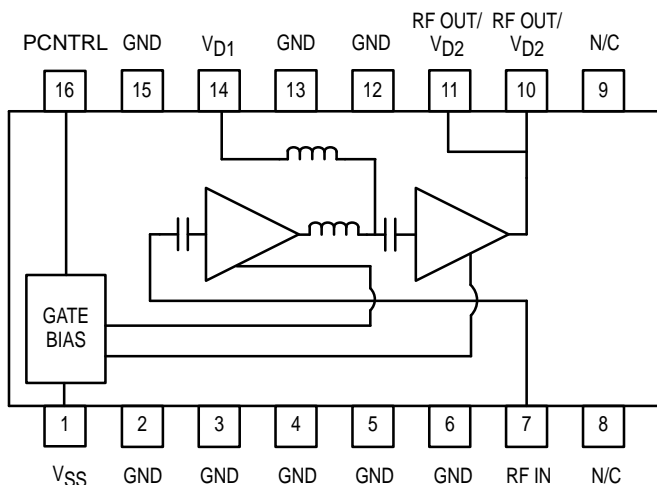

Pin Connections and Functional Block Diagram

www.DataSheet4U.com

RECOMMENDED OPERATING CONDITIONS

Parameter	Symbol	Value	Unit
Supply Voltage	V_{DD}, V_{D1}, V_{D2}	2.7 to 5	Vdc
Supply Voltage	V_{SS}	-2.5	Vdc
PA Control Voltage	PCNTRL	0.0 to V_{DD}	Vdc
RF Input Power	P_{in}	-20 to +10	dBm
Operating Frequency Range	f_{OP}	1500 to 2200	MHz

ELECTRICAL CHARACTERISTICS ($V_{D1} = V_{D2} = 3$ Vdc, $V_{SS} = -2.5$ Vdc, $T_A = 25^\circ\text{C}$, $f = 1.9$ GHz, $P_{in} = +2$ dBm, PCNTRL set for $I_{DQ} = 125$ mA, circuit configuration as shown in Figure 1)

Characteristic	Symbol	Min	Typ	Max	Unit
Power Output, Saturation	P_{SAT}	23	25	-	dBm
RF Output Power	P_{out}	20	21.5	-	dBm
Adjacent Channel Power Ratio (384 Kbps $\pi/4$ DQPSK Signal, 600 kHz Offset, $P_{out} = 21$ dBm)	P_{ACP}	-	-58	-55	dBc
RF Output 1 dB Compression	P_{1dB}	22	24	-	dBm
2nd Harmonic Output	-	-	-40	-	dBc
3rd Harmonic Output	-	-	-40	-	dBc
Supply Current	I_{DD}	-	170	210	mA
Supply Current	I_{SS}	-	200	300	μA
Supply Current	I_{PCNTRL}	-	220	300	μA
Input Return Loss	-	-	13	-	dB
Reverse Isolation	-	-	31	-	dB
Output Third Intercept	-	-	34	-	dBm
Turn On Time	-	-	1	-	μs

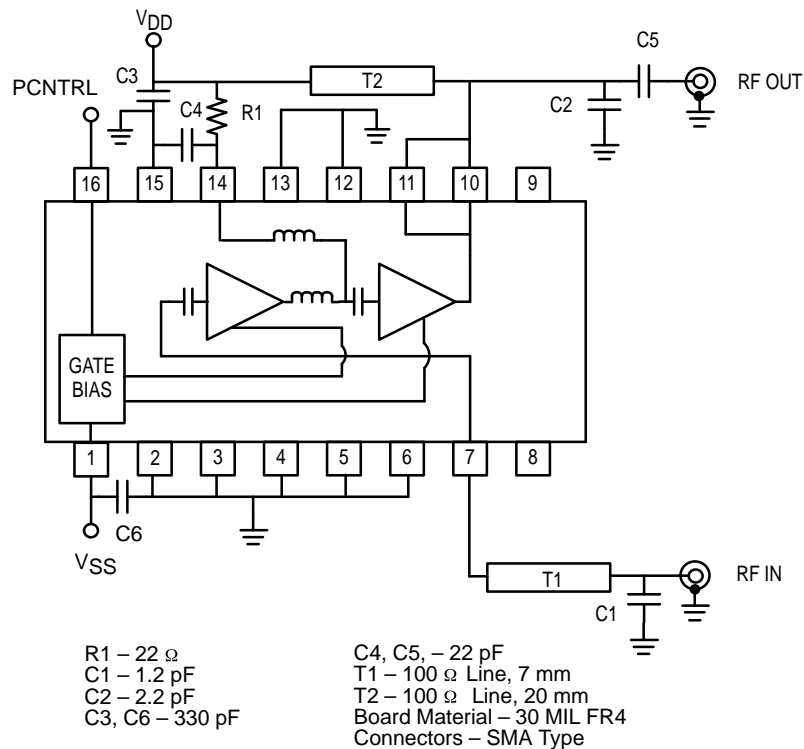

Figure 1. Applications Circuit Configuration

TYPICAL CHARACTERISTICS

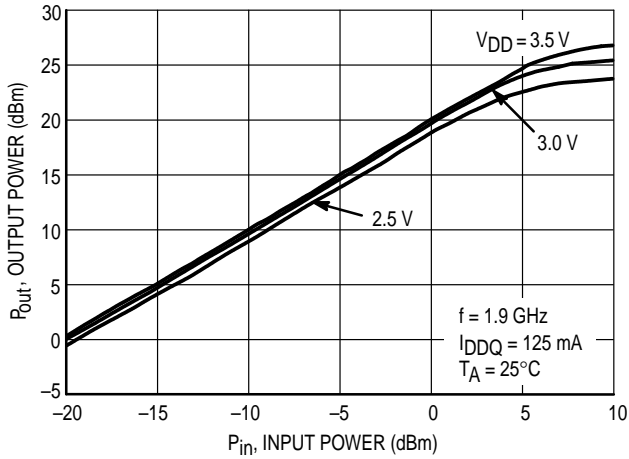

Figure 2. Output Power versus Input Power

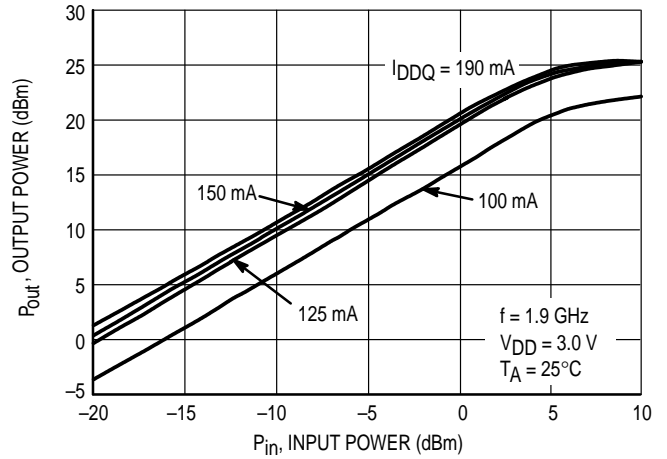

Figure 3. Output Power versus Input Power

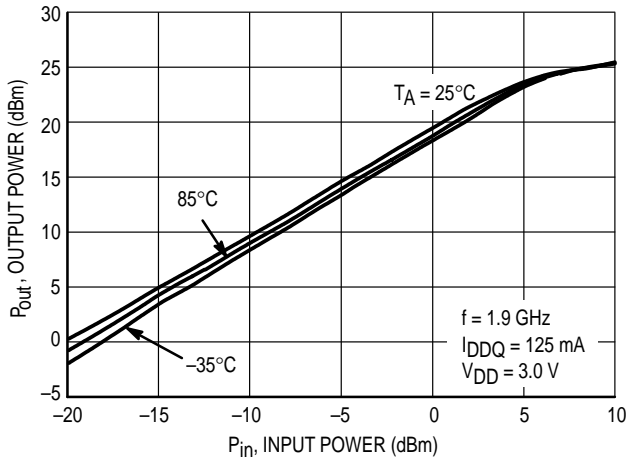

Figure 4. Output Power versus Input Power

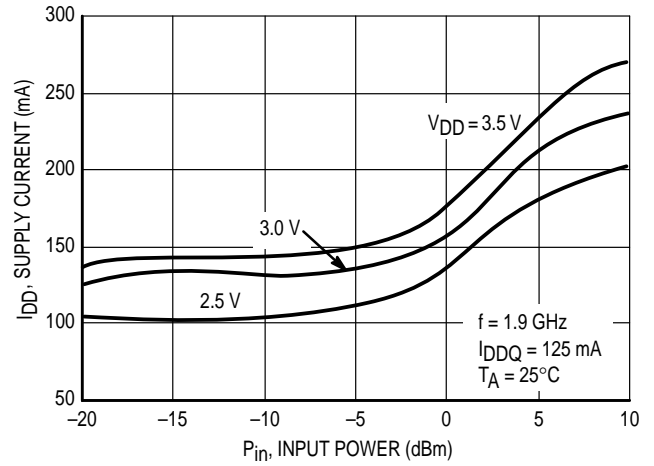

Figure 5. Supply Current versus Input Power

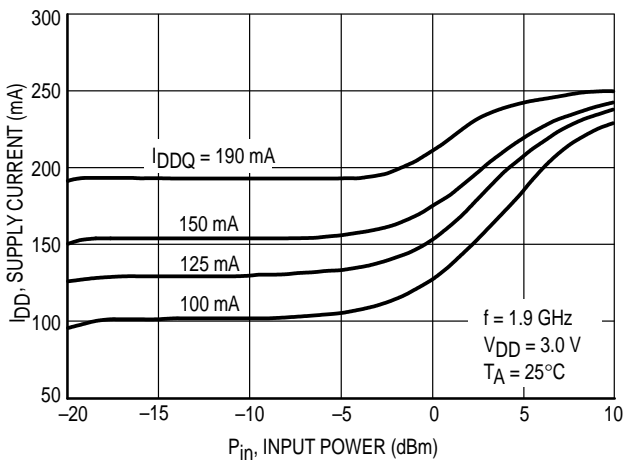

Figure 6. Supply Current versus Input Power

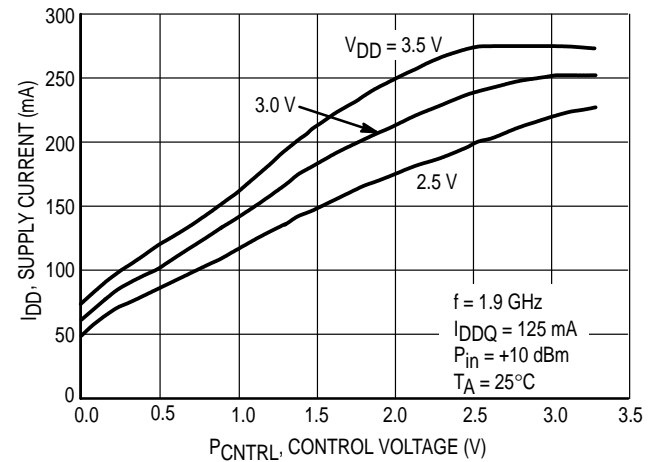

Figure 7. Supply Current versus Control Voltage

TYPICAL CHARACTERISTICS

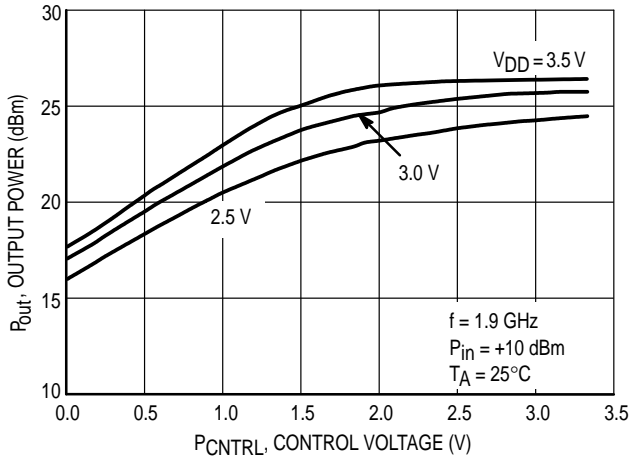

Figure 8. Output Power versus Control Voltage

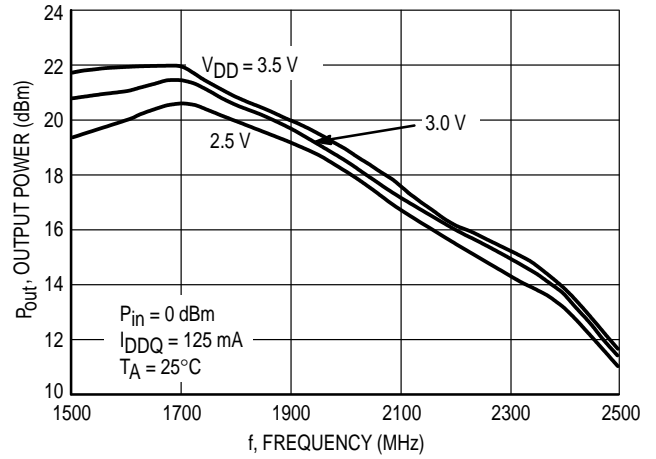

Figure 9. Output Power versus Frequency

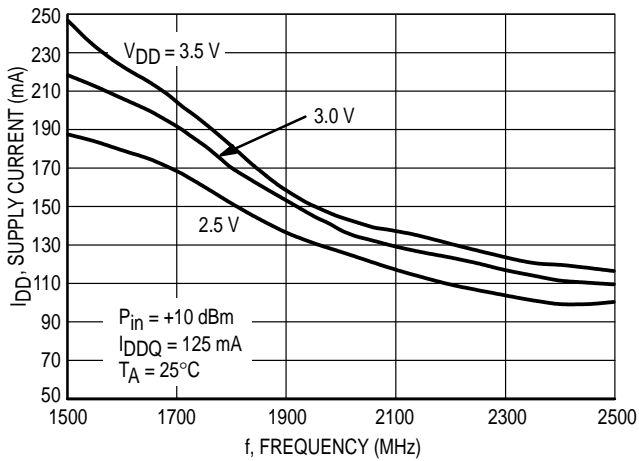

Figure 10. Supply Current versus Frequency

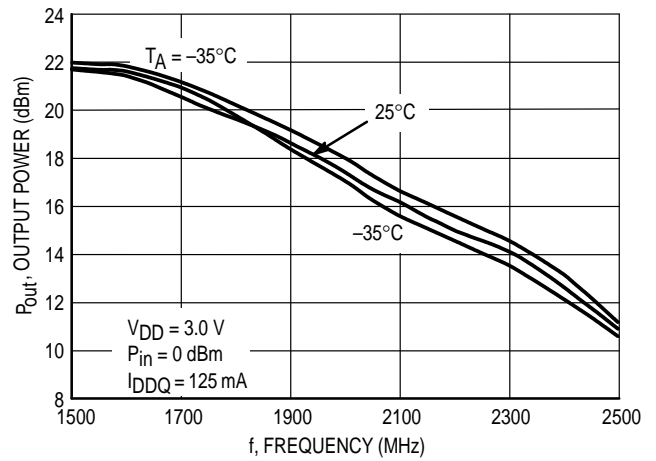

Figure 11. Output Power versus Frequency

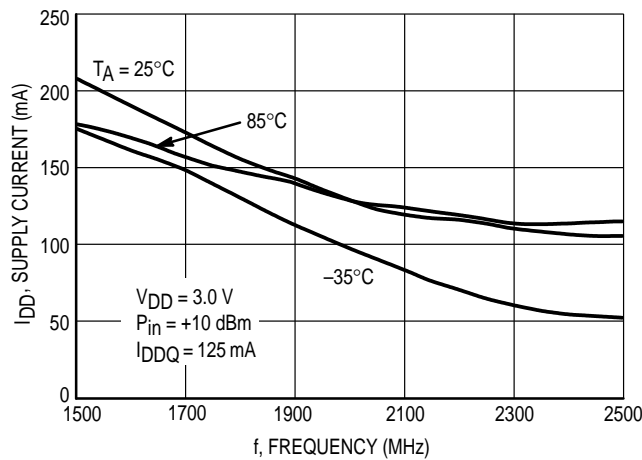

Figure 12. Supply Current versus Frequency

Table 1. Small Signal S-Parameters(V_{D1} = V_{D2} = 3 Vdc, T_A = 25°C, f = 1.9 GHz, PCNTRL set for I_{DQ} = 125 mA, no matching circuit)

f MHz	S ₁₁		S ₂₁		S ₁₂		S ₂₂	
	S ₁₁	∠φ	S ₂₁	∠φ	S ₁₂	∠φ	S ₂₂	∠φ
1.50	0.744	-76	10.99	-104	0.013	167	0.494	-177
1.55	0.697	-76	11.01	-114	0.014	164	0.520	179
1.60	0.662	-75	10.39	-124	0.015	163	0.533	174
1.65	0.645	-75	9.22	-132	0.015	160	0.528	170
1.70	0.636	-75	8.93	-135	0.016	157	0.522	167
1.75	0.623	-75	8.90	-141	0.017	157	0.515	164
1.80	0.617	-75	8.24	-148	0.018	158	0.506	161
1.85	0.612	-76	7.70	-152	0.018	155	0.497	159
1.90	0.602	-76	7.06	-158	0.019	154	0.489	156
1.95	0.599	-78	6.41	-160	0.019	154	0.481	154
2.00	0.590	-79	6.16	-160	0.021	154	0.475	152
2.05	0.581	-80	6.12	-165	0.022	152	0.469	150
2.10	0.570	-81	5.83	-170	0.022	150	0.461	148
2.15	0.562	-83	5.57	-174	0.023	151	0.458	146
2.20	0.548	-84	5.27	-178	0.024	152	0.455	144
2.25	0.538	-86	5.00	-179	0.025	152	0.450	142
2.30	0.527	-88	4.81	-179	0.027	151	0.448	141
2.35	0.512	-90	4.60	175	0.027	149	0.447	139
2.40	0.499	-92	4.43	171	0.027	146	0.447	137
2.45	0.485	-94	4.27	169	0.028	149	0.449	136
2.50	0.471	-97	4.00	163	0.030	150	0.449	134

Table 2. Small Signal S-Parameters(V_{D1} = V_{D2} = 3 Vdc, T_A = 25°C, f = 1.9 GHz, PCNTRL set for I_{DQ} = 150 mA, no matching circuit)

f MHz	S ₁₁		S ₂₁		S ₁₂		S ₂₂	
	S ₁₁	∠φ	S ₂₁	∠φ	S ₁₂	∠φ	S ₂₂	∠φ
1.50	0.752	-75	11.90	-104	0.012	169	0.480	-178
1.55	0.699	-75	11.90	-114	0.013	167	0.509	178
1.60	0.662	-75	11.19	-124	0.014	165	0.520	174
1.65	0.643	-74	9.94	-132	0.015	162	0.519	170
1.70	0.628	-74	9.60	-135	0.016	160	0.514	167
1.75	0.616	-74	9.55	-141	0.017	159	0.507	163
1.80	0.607	-74	8.81	-148	0.018	158	0.498	160
1.85	0.598	-75	8.23	-152	0.018	156	0.490	158
1.90	0.590	-75	7.54	-157	0.019	156	0.483	156
1.95	0.584	-77	6.82	-159	0.020	156	0.476	154
2.00	0.573	-78	6.55	-159	0.021	156	0.471	152
2.05	0.564	-79	6.50	-164	0.022	153	0.463	149
2.10	0.550	-81	6.17	-170	0.022	152	0.458	147
2.15	0.541	-82	5.88	-173	0.023	154	0.453	146
2.20	0.529	-84	5.56	-178	0.024	153	0.448	143
2.25	0.518	-86	5.26	-179	0.026	154	0.447	141
2.30	0.507	-88	5.04	-179	0.027	153	0.444	140
2.35	0.492	-90	4.82	176	0.028	150	0.443	138
2.40	0.481	-93	4.62	172	0.028	149	0.442	136
2.45	0.468	-95	4.45	170	0.028	152	0.444	135
2.50	0.454	-97	4.17	165	0.030	152	0.445	133

Table 3. Small Signal S-Parameters(V_{D1} = V_{D2} = 3.3 Vdc, T_A = 25°C, f = 1.9 GHz, PCNTRL set for I_{DQ} = 125 mA, no matching circuit)

f MHz	S ₁₁		S ₂₁		S ₁₂		S ₂₂	
	S ₁₁	∠φ	S ₂₁	∠φ	S ₁₂	∠φ	S ₂₂	∠φ
1.50	0.764	-73	11.50	-104	0.013	169	0.492	-177
1.55	0.711	-74	11.49	-114	0.014	166	0.518	179
1.60	0.674	-73	10.82	-124	0.014	164	0.528	174
1.65	0.652	-73	9.60	-132	0.016	162	0.524	170
1.70	0.641	-73	9.27	-135	0.016	158	0.519	167
1.75	0.628	-73	9.24	-141	0.017	158	0.507	164
1.80	0.616	-73	8.54	-148	0.017	158	0.495	161
1.85	0.607	-74	7.99	-152	0.019	155	0.489	159
1.90	0.598	-75	7.33	-157	0.019	155	0.480	157
1.95	0.590	-76	6.63	-160	0.020	156	0.471	154
2.00	0.580	-77	6.35	-160	0.021	154	0.461	153
2.05	0.569	-79	6.30	-165	0.021	152	0.454	150
2.10	0.556	-80	5.98	-170	0.023	151	0.445	148
2.15	0.546	-82	5.70	-174	0.022	154	0.439	147
2.20	0.534	-84	5.39	-178	0.024	152	0.436	144
2.25	0.523	-86	5.11	-179	0.025	153	0.430	142
2.30	0.510	-88	4.90	-179	0.026	150	0.427	141
2.35	0.499	-90	4.70	175	0.027	149	0.424	139
2.40	0.486	-93	4.48	171	0.027	148	0.422	137
2.45	0.473	-95	4.31	169	0.027	150	0.422	135
2.50	0.463	-98	4.05	164	0.029	151	0.420	133

Table 4. Small Signal S-Parameters(V_{D1} = V_{D2} = 3.3 Vdc, T_A = 25°C, f = 1.9 GHz, PCNTRL set for I_{DQ} = 150 mA, no matching circuit)

f MHz	S ₁₁		S ₂₁		S ₁₂		S ₂₂	
	S ₁₁	∠φ	S ₂₁	∠φ	S ₁₂	∠φ	S ₂₂	∠φ
1.50	0.756	-74	12.03	-105	0.012	168	0.483	-178
1.55	0.702	-75	12.02	-115	0.013	168	0.509	178
1.60	0.663	-74	11.33	-125	0.014	162	0.519	174
1.65	0.644	-73	10.03	-133	0.015	161	0.518	170
1.70	0.628	-73	9.69	-136	0.016	160	0.514	167
1.75	0.614	-73	9.62	-142	0.016	160	0.502	164
1.80	0.603	-74	8.88	-149	0.018	159	0.494	161
1.85	0.596	-74	8.30	-153	0.018	157	0.485	159
1.90	0.584	-75	7.59	-158	0.019	156	0.476	157
1.95	0.577	-76	6.87	-160	0.020	156	0.466	154
2.00	0.567	-77	6.58	-160	0.021	155	0.458	152
2.05	0.559	-79	6.50	-165	0.022	152	0.450	150
2.10	0.545	-80	6.17	-171	0.022	152	0.443	148
2.15	0.536	-82	5.87	-175	0.022	152	0.436	147
2.20	0.524	-84	5.54	-179	0.024	153	0.429	145
2.25	0.512	-86	5.25	-180	0.025	153	0.424	143
2.30	0.500	-88	5.03	180	0.026	152	0.422	141
2.35	0.486	-90	4.78	174	0.027	149	0.418	139
2.40	0.477	-93	4.58	170	0.027	149	0.414	137
2.45	0.462	-95	4.40	168	0.027	150	0.413	136
2.50	0.452	-98	4.13	163	0.029	151	0.412	134

PACKAGE DIMENSIONS

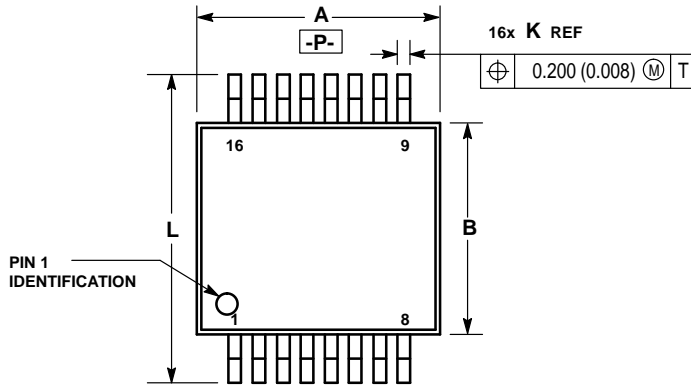

NOTES:

1. DIMENSIONING AND TOLERANCING PER ANSI Y14.5M, 1982.
2. CONTROLLING DIMENSION: MILLIMETER.
3. DIMENSION A DOES NOT INCLUDE MOLD FLASH, PROTRUSIONS OR GATE BURRS. MOLD FLASH OR GATE BURRS SHALL NOT EXCEED 0.15 (0.006) PER SIDE.
4. DIMENSION B DOES NOT INCLUDE INTERLEAD FLASH OR PROTRUSION. INTERLEAD FLASH OR PROTRUSION SHALL NOT EXCEED 0.25 (0.010) PER SIDE.
5. DIMENSION K DOES NOT INCLUDE DAMBAR PROTRUSION. ALLOWABLE DAMBAR PROTRUSION SHALL BE 0.08 (0.003) TOTAL EXCESS OF THE K DIMENSION AT MAXIMUM MATERIAL CONDITION.
6. TERMINAL NUMBERS ARE SHOWN FOR REFERENCE ONLY.
7. DIMENSIONS A AND B ARE TO BE DETERMINED AT DATUM PLANE -U-.

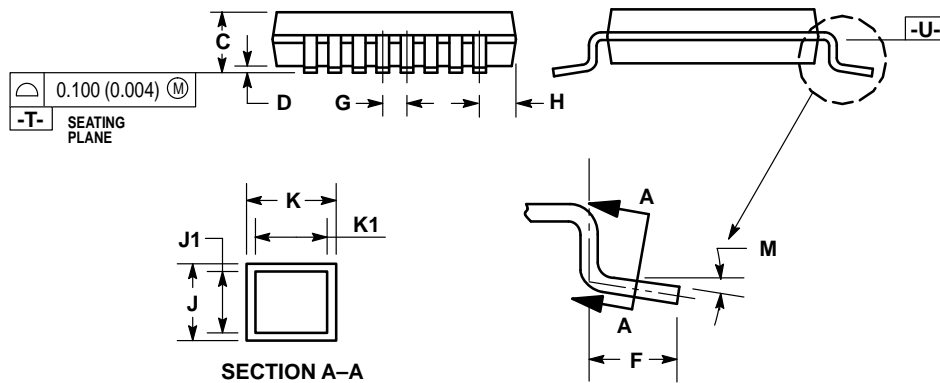

DIM	MILLIMETERS		INCHES	
	MIN	MAX	MIN	MAX
A	—	5.10	—	0.200
B	4.30	4.50	0.169	0.177
C	—	1.20	—	0.047
D	0.05	0.25	0.002	0.010
F	0.45	0.55	0.018	0.022
G	0.65 BSC		0.026 BSC	
H	0.22	0.23	0.009	0.010
J	0.09	0.24	0.004	0.009
J1	0.09	0.18	0.004	0.007
K	0.16	0.32	0.006	0.013
K1	0.16	0.26	0.006	0.010
L	6.30	6.50	0.248	0.256
M	0° 10°		0° 10°	

**CASE 948C-03
ISSUE B**

Motorola reserves the right to make changes without further notice to any products herein. Motorola makes no warranty, representation or guarantee regarding the suitability of its products for any particular purpose, nor does Motorola assume any liability arising out of the application or use of any product or circuit, and specifically disclaims any and all liability, including without limitation consequential or incidental damages. "Typical" parameters which may be provided in Motorola data sheets and/or specifications can and do vary in different applications and actual performance may vary over time. All operating parameters, including "Typicals" must be validated for each customer application by customer's technical experts. Motorola does not convey any license under its patent rights nor the rights of others. Motorola products are not designed, intended, or authorized for use as components in systems intended for surgical implant into the body, or other applications intended to support or sustain life, or for any other application in which the failure of the Motorola product could create a situation where personal injury or death may occur. Should Buyer purchase or use Motorola products for any such unintended or unauthorized application, Buyer shall indemnify and hold Motorola and its officers, employees, subsidiaries, affiliates, and distributors harmless against all claims, costs, damages, and expenses, and reasonable attorney fees arising out of, directly or indirectly, any claim of personal injury or death associated with such unintended or unauthorized use, even if such claim alleges that Motorola was negligent regarding the design or manufacture of the part. Motorola and  are registered trademarks of Motorola, Inc. Motorola, Inc. is an Equal Opportunity/Affirmative Action Employer.

Mfax is a trademark of Motorola, Inc.

How to reach us:

USA/EUROPE/Locations Not Listed: Motorola Literature Distribution;
P.O. Box 5405, Denver, Colorado 80217. 303-675-2140 or 1-800-441-2447

JAPAN: Nippon Motorola Ltd.: SPD, Strategic Planning Office, 4-32-1,
Nishi-Gotanda, Shinagawa-ku, Tokyo 141, Japan. 81-3-5487-8488

Mfax™: RMFAX0@email.sps.mot.com – TOUCHTONE 602-244-6609
– US & Canada ONLY 1-800-774-1848

ASIA/PACIFIC: Motorola Semiconductors H.K. Ltd.; 8B Tai Ping Industrial Park,
51 Ting Kok Road, Tai Po, N.T., Hong Kong. 852-26629298

INTERNET: <http://motorola.com/sps>

