

## GNSS Low Noise Amplifier

### PRODUCT DESCRIPTION

The MS2663 is high-gain, low-noise amplifier (LNA), supporting for L1 frequency band, multi-mode global satellite positioning, such as GPS, BD2, GALILEO, GLONASS and so on.

### FEATURES

- Support for BDS, GPS, GALILEO, GLONASS Global Navigation Satellite Systems in L1 Frequency Band
- Typical Noise Figure : 0.95dB (including board-stage loss)
- Typical Power Gain : 21.5dB
- Typical Output P1dB : 2dBm
- Operating Frequency : 1550MHz to 1615MHz
- Current Consumption : 4.2mA@2.85V
- Wide Power Supply : 1.2V~3.6V
- ESD( HBM ) : 2kV
- Integrated 50Ω Output Match Circuit
- Simple Peripherals

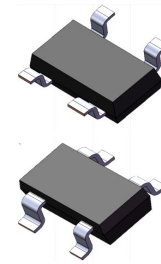

SOT343

### APPLICATIONS

- Automatic Navigation
- Location Mobile Device
- Personal Navigation Device
- Phone with GPS
- Notebook/Pad
- Underwater Navigation
- Aviation Device

### PRODUCT SPECIFICATION

Part Number	Package	Marking
MS2663	SOT343	63T

**PIN CONFIGURATION**

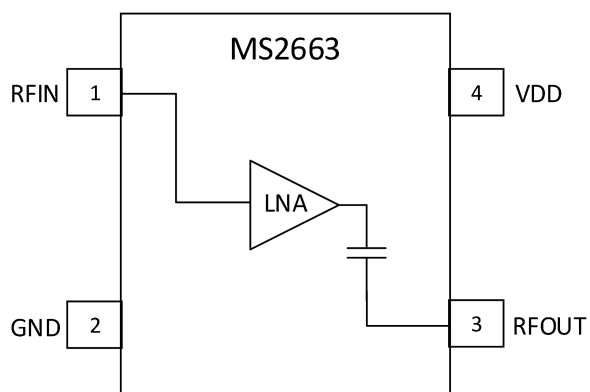

**PIN DESCRIPTION**

Pin	Name	Type	Description
1	RFIN	I	RF Input
2	GND	-	Ground
3	RFOUT	O	RF Output
4	VDD	-	Power Supply

**ABSOLUTE MAXIMUM RATINGS**

Any exceeding absolute maximum rating application causes permanent damage to device. Because long-time absolute operation state affects device reliability. Absolute ratings just conclude from a series of extreme tests. It doesn't represent chip can operate normally in these extreme conditions.

Parameter	Ratings	Unit
Power Supply (VDD)	-0.3 ~ 5.0	V
RF Input (RFIN)	-0.3 ~ 2.0	V
RF Output (RFOUT)	-0.3 ~ 5.0	V
RF Input Power	+20	dBm
Operating Temperature	-40 ~ +120	°C
Lead Temperature(Soldering,10s)	+260	°C

## ELECTRICAL CHARACTERISTICS

### DC Characteristics

At room temperature

Parameter	Min	Typ	Max	Unit
Power Supply	1.2	2.85	3.6	V
Power Supply Current	3.2	4.2	4.4	mA

### AC Characteristics

2.85V power supply, at room temperature.

Parameter	Typ			Unit
Operating Frequency	1561.098	1575.42	1602	MHz
Input Match Inductance L1	Transmission Line (Note 2)			nH
Power Gain	21.5	21.5	21.3	dB
Noise Figure (Note 1)	0.9	0.9	0.9	dB
Input Return Loss	12.2	13.4	16.3	dB
Output Return Loss	23.0	29.8	18.7	dB
Reverse Isolation	28.8	28.3	28.0	dB
Output P1dB	2	2	2	dBm

Note:

1. Actual measurement values (including PCB, SMA and other board-stage losses).
2. The specified dimension parameters of transmission line refer to PCB description.

**TYPICAL OPERATION CHARACTERISTICS  
(ACTUAL MEASUREMENT VALUES AT ROOM TEMPERATURE)**

The typical operating conditions: evaluation board test, 25°C temperature, 3V power supply, input center frequency signal, unless otherwise noted.

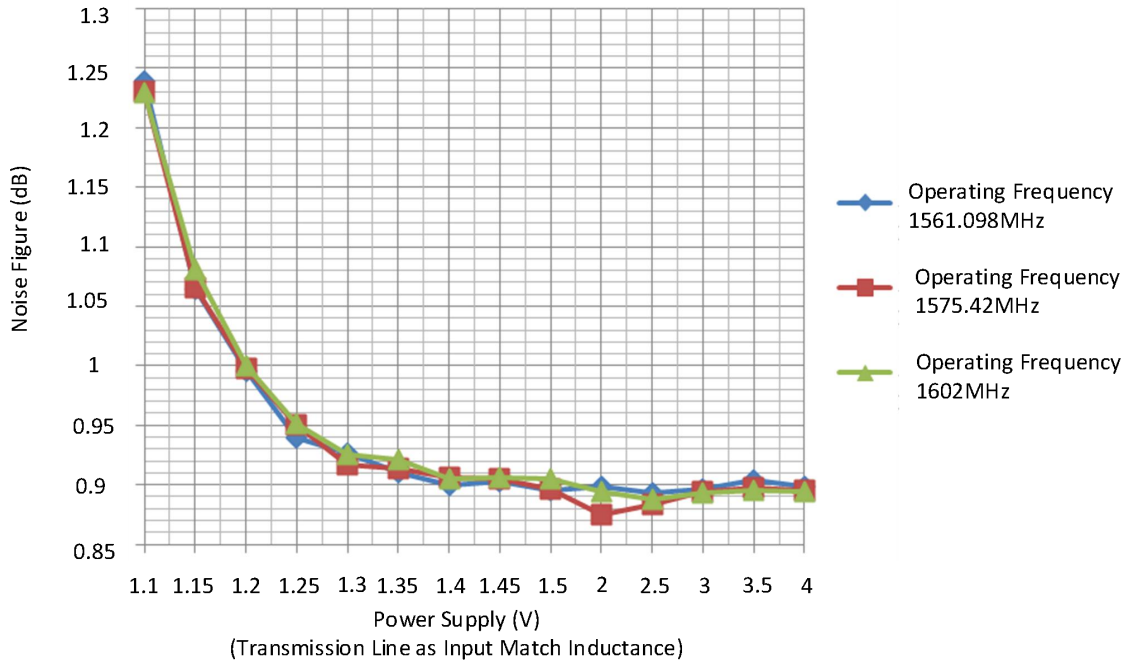

Figure 1. Noise Figure VS. Power Supply

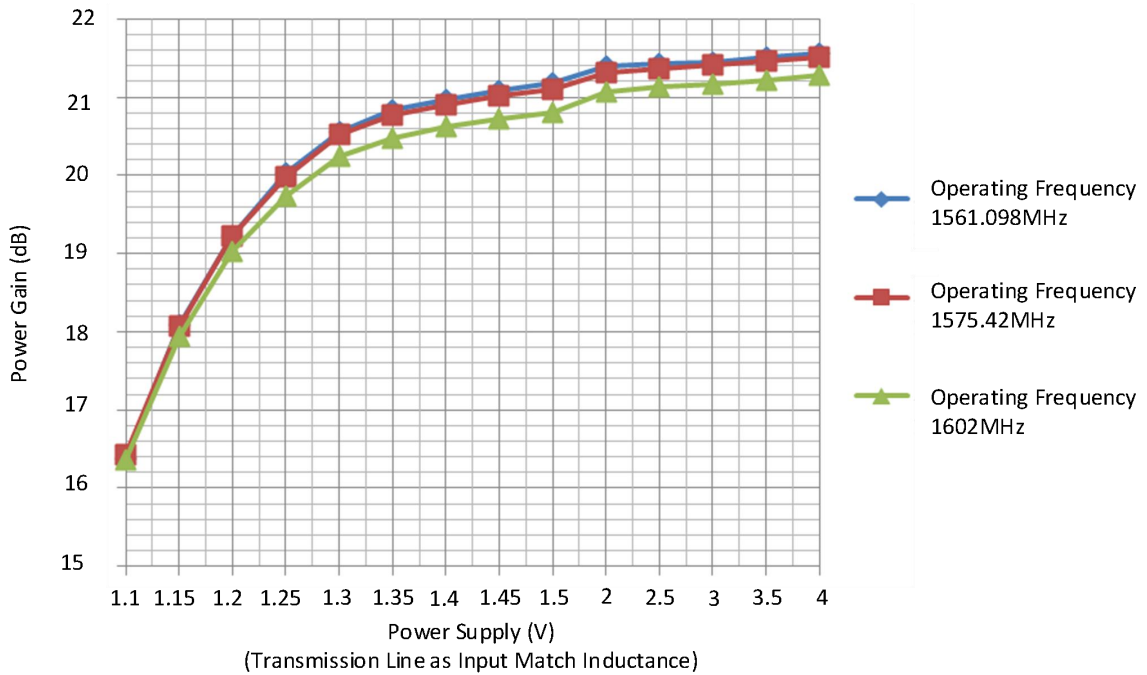

Figure 2. Power Gain VS. Power Supply

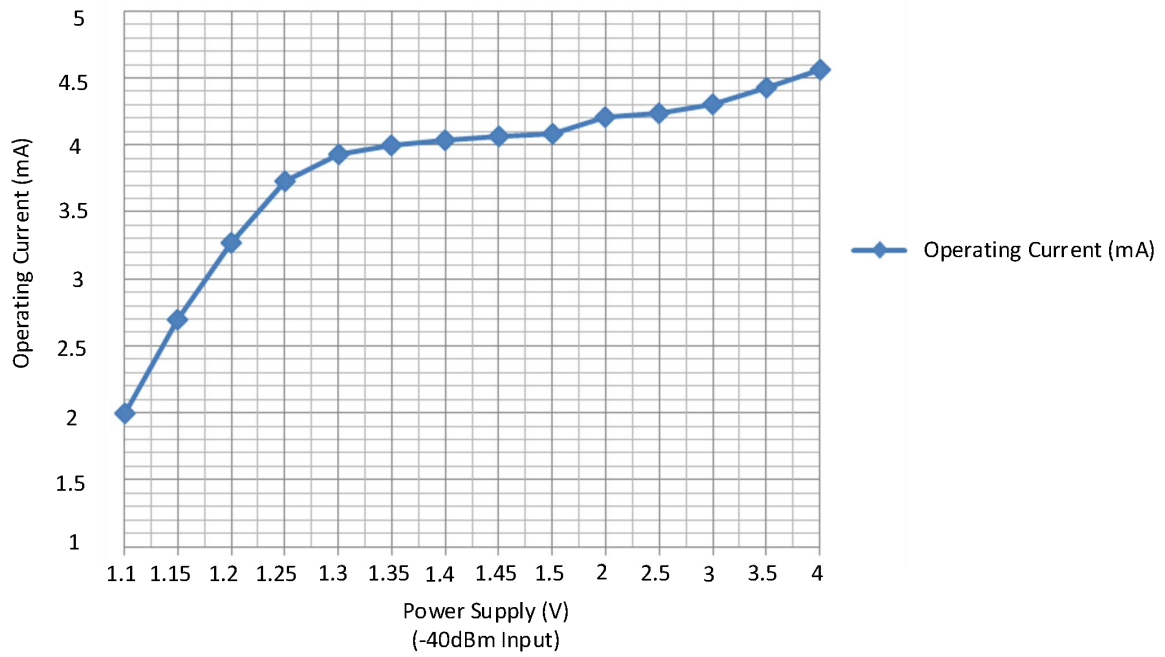

Figure 3. Operating Current VS. Power Supply

**TYPICAL APPLICATION**

**Typical Application 1 (Chip Performance Evaluation Board)**

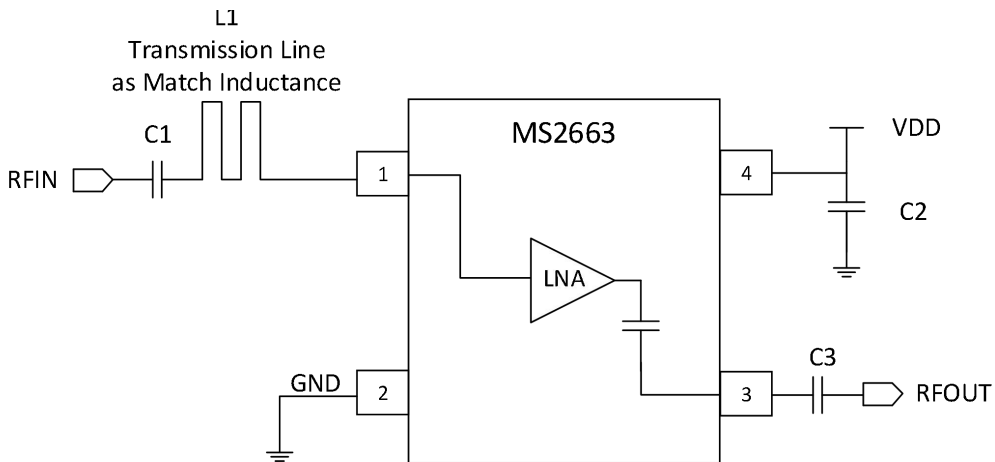

Figure 4. Typical Application Block Diagram 1

Table 1. Peripheral Component Description

Component	Description
C1	Input Block Capacitor; Murata GRM155R71H471KA01D C0402; 470pF ±10%;50V X7R
C3	Output Block (Match) Capacitor; Murata GRM1555C1H3R0CZ01D C0402 3pF ±0.25pF; 50V C0G
C2	Power Bypass Capacitor; Murata GRM155R71C104KA88D C0402; 100nF ±10%;16V X7R
L1	Transmission Line or Discrete Inductance; Murata LQG15HS5N6S02D L0402 Lamination;5.6nH ±0.3nH

**Evaluation Test Board, PCBA Description**

The MS2663 evaluation test board adopts two layers board with FR4. The thickness is 0.8mm. The average thickness of copper layer is 30um and area is 14×17mm<sup>2</sup>. As shown in following diagram, U1 is the MS2663; C1 is input block capacitor; C2 is output block (match) capacitor; C3 is power bypass capacitor. Power uses SMA to join up.

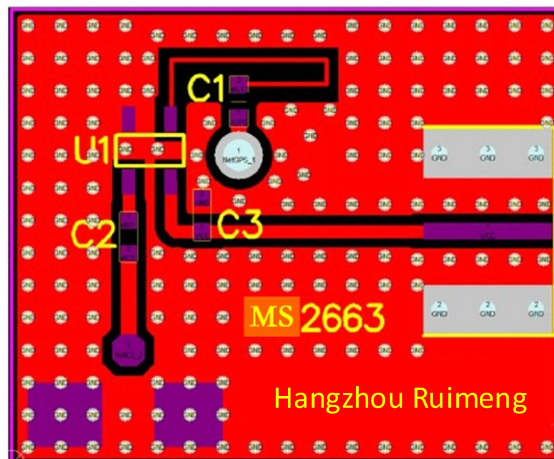

Circuit principle diagram is as follows:

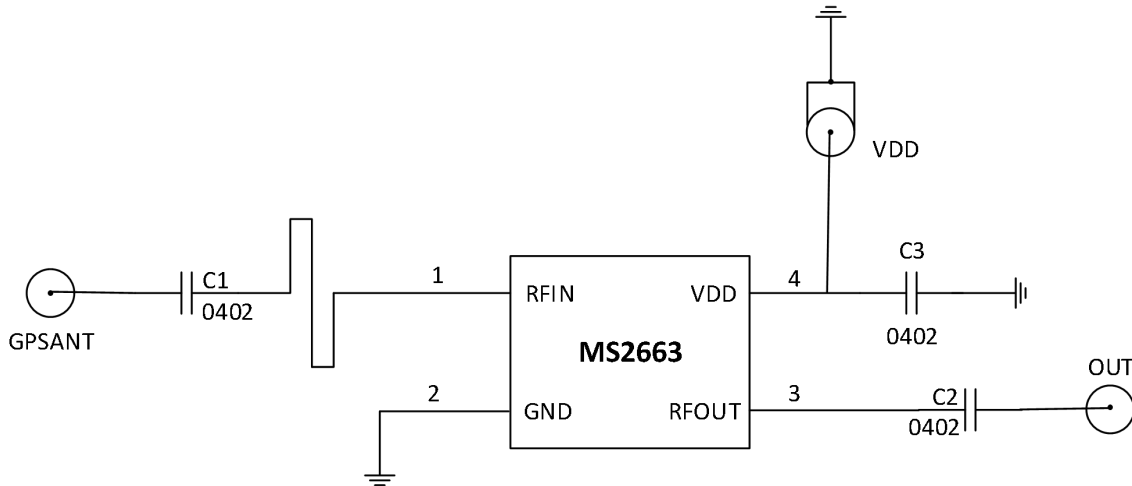
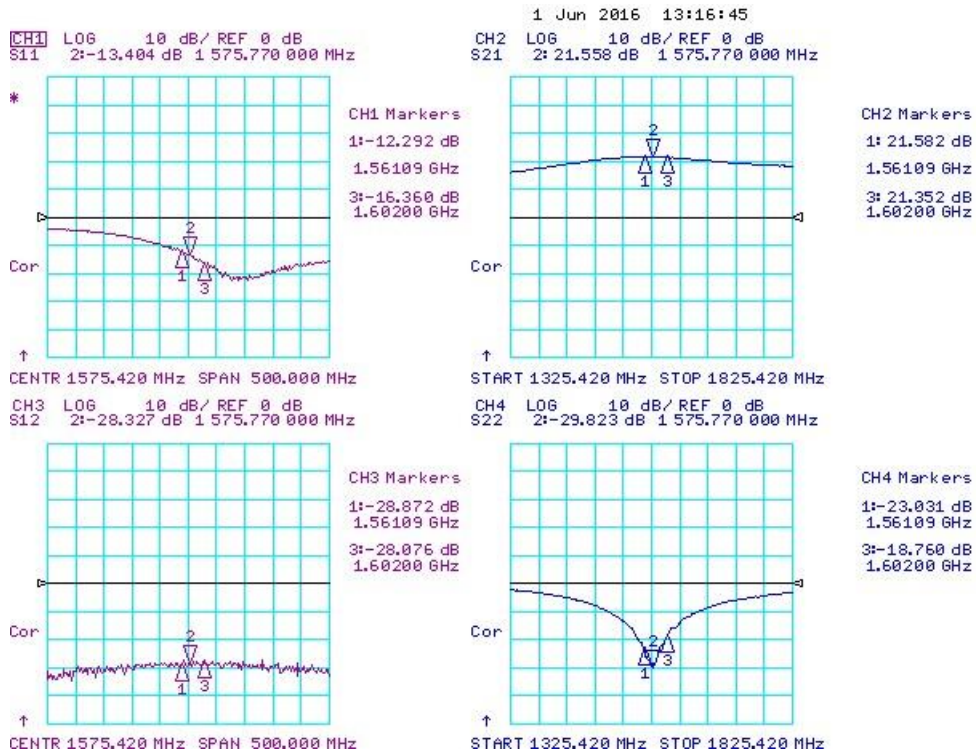

Table 2. Peripheral Component Description

Component	Description
C1	Input Block Capacitor; Murata GRM155R71H471KA01D C0402;470pF ±10%;50V X7R
C2	Output Block (Match) Capacitor; Murata GRM1555C1H3R0CZ01D C0402 3pF ±0.25pF; 50V COG
C3	Power Bypass Capacitor; Murata GRM155R71C104KA88D C0402;100nF ±10%;16V X7R

The following diagrams are actual measurement values for S parameter under 2.85V power supply in three navigation modes, BD2, GPS and GLONASS.





The following diagram is actual measurement values for noise figure and corresponding gain under 2.85V power supply in three navigation modes, BD2, GPS and GLONASS.

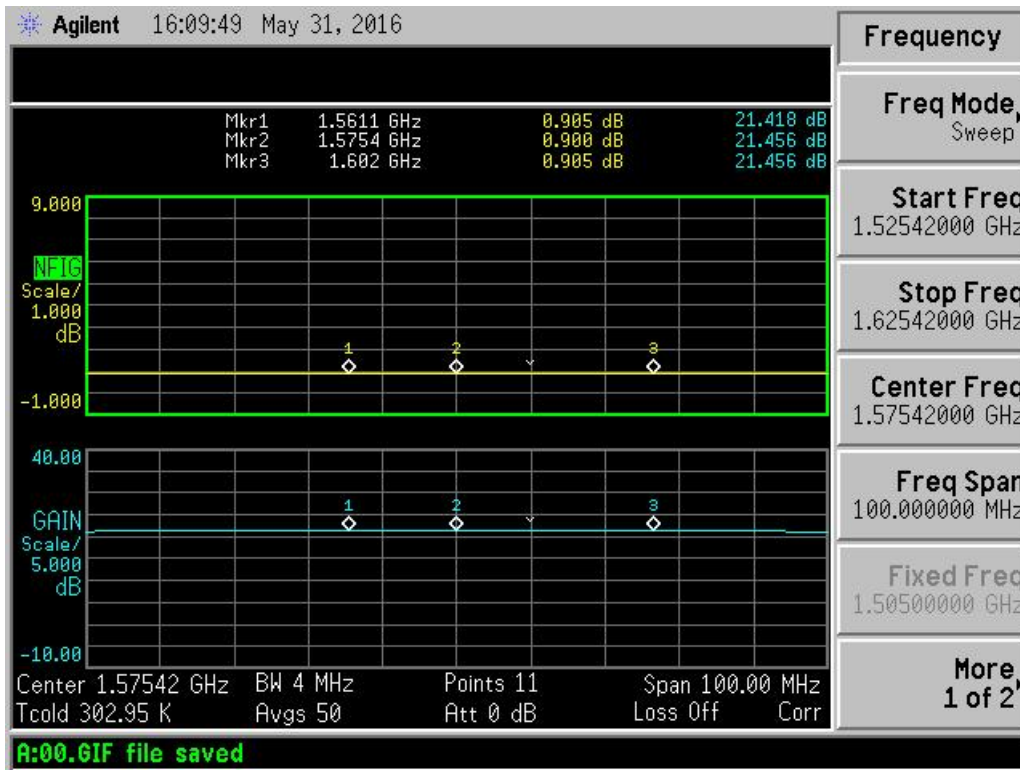

**Typical Application 2 (No External Inductance, Antenna Module Reference Board)**

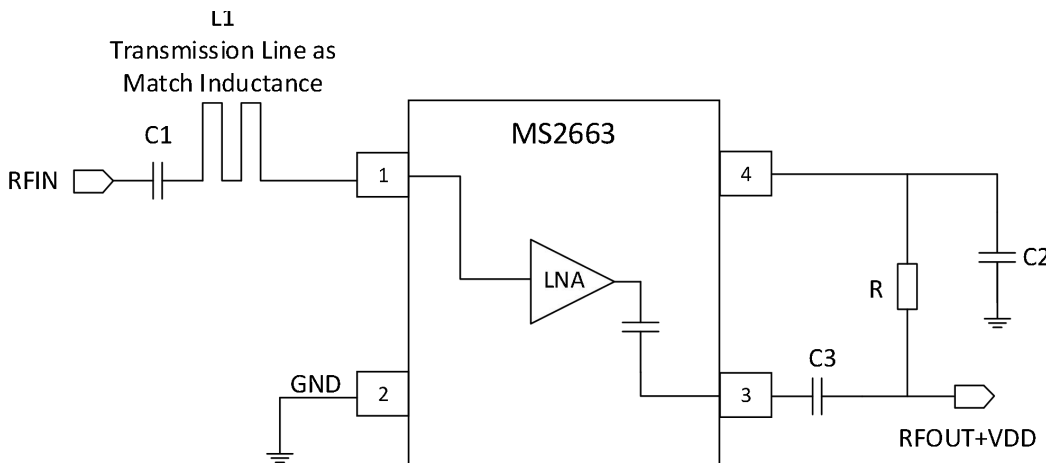
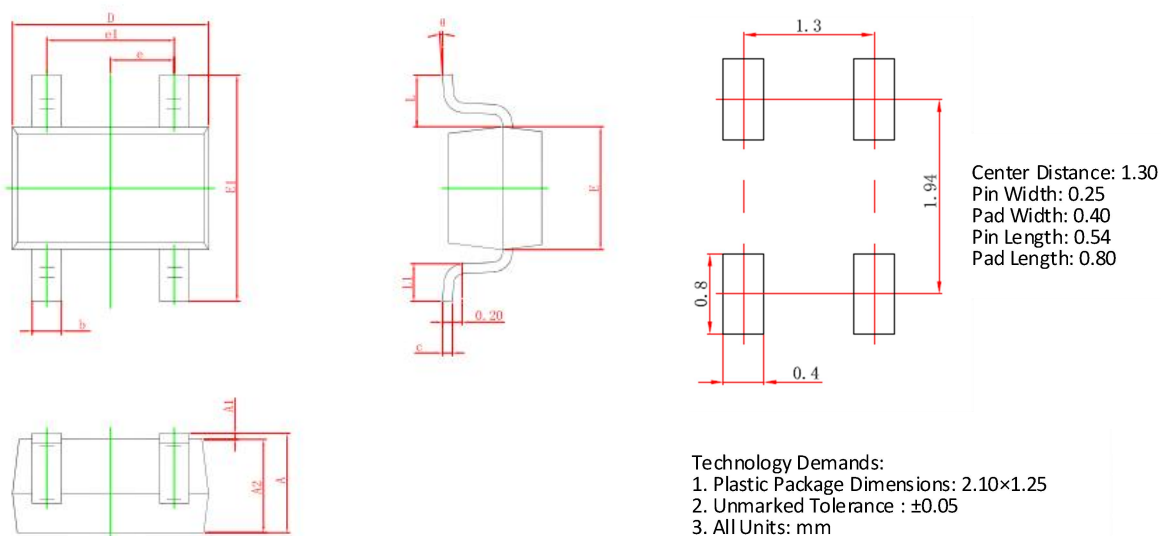

Figure 5. Typical Application Block Diagram 2

Peripheral component descriptions see Table 1.

**PACKAGE OUTLINE DIMENSIONS**

**SOT343**



Symbol	Dimensions in Millimeter		Dimensions in Inches	
	Min	Max	Min	Max
A	0.900	1.100	0.035	0.043
A1	0.000	0.100	0.000	0.004
A2	0.900	1.000	0.035	0.039
b	0.150	0.350	0.006	0.014
c	0.080	0.150	0.003	0.006
D	2.000	2.200	0.079	0.087
E	1.150	1.350	0.045	0.053
E1	2.150	2.450	0.085	0.096
e	0.650 TYP.		0.026 TYP.	
e1	1.200	1.400	0.047	0.055
L	0.525 REF.		0.021 REF.	
L1	0.260	0.460	0.010	0.018
θ	0°	8°	0°	8°

## MARKING and PACKAGING SPECIFICATIONS

### 1. Marking Drawing Description

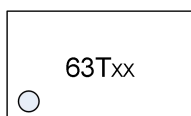

Product Name : 63T

Product Code : XX

### 2. Marking Drawing Demand

Laser printing, contents in the middle, font type Arial.

### 3. Packaging Specifications

Device	Package	Piece/Reel	Reel/Box	Piece /Box	Box/Carton	Piece/Carton
MS2663	SOT343	3000	10	30000	4	120000

**STATEMENT**

- All Revision Rights of Datasheets Reserved for Ruimeng. Don't release additional notice.  
Customer should get latest version information and verify the integrity before placing order.
- When using Ruimeng products to design and produce, purchaser has the responsibility to observe safety standard and adopt corresponding precautions, in order to avoid personal injury and property loss caused by potential failure risk.
- The process of improving product is endless. And our company would sincerely provide more excellent product for customer.



#### MOS CIRCUIT OPERATION PRECAUTIONS

Static electricity can be generated in many places. The following precautions can be taken to effectively prevent the damage of MOS circuit caused by electrostatic discharge:

1. The operator shall ground through the anti-static wristband.
2. The equipment shell must be grounded.
3. The tools used in the assembly process must be grounded.
4. Must use conductor packaging or anti-static materials packaging or transportation.



+86-571-89966911



Rm701, No.9 Building, No. 1 WeiYe Road, Puyan Street, Binjiang District, Hangzhou, Zhejiang



[http:// www.relmon.com](http://www.relmon.com)