

INCH-POUND

MS27183J  
 11 MARCH 1996  
 SUPERSEDING  
 MS27183H  
 19 JUNE 1995

MILITARY SPECIFICATION SHEET  
 WASHER, FLAT (ROUND, STEEL,  
 CADMIUM PLATED) GENERAL PURPOSE

THIS SPECIFICATION IS APPROVED FOR USE BY ALL DEPARTMENTS  
 AND AGENCIES OF THE DEPARTMENT OF DEFENSE

THE REQUIREMENTS FOR ACQUIRING THE PRODUCT DESCRIBED HEREIN SHALL CONSIST  
 OF THIS SPECIFICATION SHEET AND THE ISSUE OF THE FOLLOWING DOCUMENT  
 LISTED IN THAT ISSUE OF THE DEPARTMENT OF DEFENSE INDEX OF SPECIFICATIONS  
 AND STANDARDS (DODISS) SPECIFIED IN THE SOLICITATION FF-W-92

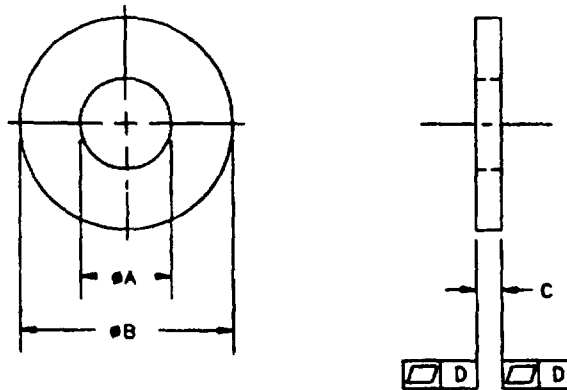

TABLE 1 DASH NUMBERS AND DIMENSIONS.

DASH NUMBER	øA	TOLERANCE		øB	TOLERANCE		C THICKNESS (BASIC)	TOLERANCE		D
		(+)	(-)		(+)	(-)		MAX	MIN	
-1	078	000	005	188	000	005	.020	.025	.016	.005
-2	.094	000	005	250	.000	005	.020	.025	.016	.005
-3	125	.000	005	250	.000	.005	.022	.028	.017	.005
-4	125	008	005	312	008	005	.032	.040	.025	.005
-5	156	008	005	312	008	005	.035	.048	.027	.005
-43	156	008	.005	.250	.000	015	.016	.020	.013	.005
-6	156	008	005	.375	015	005	.049	.065	.036	.005
-7	188	008	.005	.375	.015	.005	.049	.065	.036	.005
-41	188	008	.005	.438	015	005	.049	.065	.036	.005
-8	.219	.008	005	.438	.015	.005	.049	.065	.036	.005
-42	219	008	005	.500	.015	.005	.049	.065	.036	.005
-44	125	008	.005	.375	.015	.005	.032	.040	.025	.005
-45	141	008	005	.281	005	005	.032	.040	.025	.005
-46	188	.008	.005	.500	.015	005	.065	.080	.051	.005
-47	.219	.008	.005	.385	.005	015	.032	.040	.025	.005
-48	250	005	.020	.938	005	015	.065	.080	.051	.005
-49	250	015	005	.562	.015	.005	.032	.040	.025	.005
-50	250	015	005	.625	015	005	.032	.040	.025	.005
9	250	015	005	.562	015	005	.065	.080	.051	.005
-10	281	015	.005	.625	015	005	.065	.080	.051	.005

J ENTIRE DOCUMENT REVISED

## MS27183J

TABLE 1 DASH NUMBERS AND DIMENSIONS. (continued)

DASH NUMBER	#A	TOLERANCE		#B	TOLERANCE		C THICKNESS (BASIC)	TOLERANCE		D
		(+)	(-)		(+)	(-)		MAX	MIN	
-51	250	015	015	1 000	015	005	065	080	051	005
-52	281	015	005	734	015	007	065	080	051	005
-11	312	015	005	734	015	007	065	080	051	005
-12	344	015	005	688	015	007	065	080	051	005
-13	375	015	005	875	030	007	083	104	064	005
-53	312	015	005	875	015	015	065	075	051	005
-54	312	015	005	500	015	005	035	048	027	005
-55	375	015	005	734	015	005	083	094	064	005
-56	375	015	005	625	030	010	035	048	027	005
-57	406	015	005	875	015	007	063	070	051	005
-58	412	010	005	625	005	.005	032	040	025	005
-14	406	015	005	812	015	007	065	080	051	005
-15	438	015	005	1 000	030	007	083	104	064	005
-59	438	015	005	1 365	015	007	083	104	064	005
-60	438	015	005	875	015	.007	065	080	051	005
-61	438	.015	005	1 625	015	007	065	104	051	005
-62	469	005	020	734	030	007	065	080	051	005
-16	469	015	.005	922	015	007	065	080	051	005
-17	500	015	005	1 250	.030	.007	083	104	064	005
-18	531	015	005	1 062	030	007	095	121	074	005
-19	562	015	005	1,375	030	007	109	132	086	005
-20	594	015	005	1 156	030	007	095	121	074	005
-63	656	015	010	2 125	030	007	095	115	080	005
-21	656	030	007	1 312	030	007	095	121	074	005
-22	688	030	007	1 750	030	007	134	160	108	.005
-23	812	.030	007	1 469	030	007	134	160	.108	005
-24	812	030	007	2,000	030	007	148	177	122	005
-25	938	.030	007	1 750	030	.007	134	160	108	010
-26	938	030	007	2 250	030	007	165	192	.136	010
-27	1 062	030	007	2 000	.030	007	134	160	108	010
-28	1 062	030	007	2,500	030	007	165	192	136	010
-29	1,250	030	007	2 750	030	.007	.165	.192	136	.010
-30	1,375	.030	.007	3,000	.030	007	165	192	.136	010
-31	1,500	.045	.010	3 250	.045	.010	180	213	.153	010
-32	1 625	045	010	3,500	045	010	180	.213	153	010
-33	1 750	045	010	3,750	045	010	180	.213	153	010
-34	1 875	045	.010	4,000	.045	010	.180	.213	.153	.010
-35	2,000	.045	010	4 250	.045	.010	180	.213	153	010
-36	2 125	045	010	4 500	045	.010	180	213	153	010
-37	2 375	045	010	4 750	045	010	.220	.248	193	010
-38	2,625	045	010	5,000	045	010	238	280	.210	010
-39	2 875	065	010	5 250	065	010	.259	310	228	.010
-40	3 125	.065	010	5 500	065	010	284	327	249	010

## REQUIREMENTS

- MATERIAL. STEEL, CARBON GRADES 1005 THRU 1020 (UNS G10050 THRU UNS G10200), IN ACCORDANCE WITH ASTM A108, ASTM A109 OR ASTM A569, ANY TEMPER
- PROTECTIVE COATING AND SURFACE TREATMENT. CADMIUM PLATE IN ACCORDANCE WITH QQ-P-416, TYPE II, CLASS 3
- SURFACE TEXTURE. BEARING SURFACE ROUGHNESS SHALL NOT EXCEED 125 MICRONS (Ra) IN ACCORDANCE WITH ANSI/ASME B46.1
- PART NUMBER. THE PART NUMBER SHALL CONSIST OF THE BASIC MS NUMBER FOLLOWED BY A DASH NUMBER FROM TABLE 1

EXAMPLE MS27183-1

DASH NUMBER

BASIC MS NUMBER

MS27183-1 INDICATES WASHER FLAT (ROUND STEEL CADMIUM PLATED) INSIDE DIAMETER 078, OUTSIDE DIAMETER 188, THICKNESS 020

## NOTES

- 1 ALL DIMENSIONS ARE IN INCHES
- 2 IN THE EVENT OF A CONFLICT BETWEEN THE TEXT OF THIS DOCUMENT AND THE REFERENCES CITED HEREIN, THE TEXT OF THIS DOCUMENT SHALL TAKE PRECEDENCE
- 3 UNLESS OTHERWISE SPECIFIED, ISSUE OF REFERENCED DOCUMENTS ARE THOSE IN EFFECT AT THE TIME OF SOLICITATION

CADMIUM OR ZINC COATED STEEL WASHERS ONLY, PREVIOUSLY SPECIFIED ON MS15795 WERE CANCELLED AND SUPERSEDED BY CADMIUM PLATED STEEL WASHERS SPECIFIED HEREIN

UNCOATED STEEL WASHERS AND PHOSPHATE COATED STEEL WASHERS, COVERED BY DASH NUMBERS GIVEN ON MS15795, ARE CANCELLED/INACTIVATED AFTER THE INDICATED APPROVAL DATE FOR REVISION A OF SUPERSEDING STANDARD MS27183 USE THE DASH NUMBERS GIVEN IN THE PRECEDING SHEET OF THIS STANDARD THE CANCELLED WASHERS CAN NOT ALWAYS REPLACE THE NEW WASHERS AND SHOULD BE USED UNTIL EXISTING STOCK IS DEPLETED THEN USE ONLY THE NEW WASHERS FOR DESIGN AND REPLACEMENT REPLACEMENT SHALL BE IN ACCORDANCE WITH THIS TABLE

TABLE II INTERCHANGEABILITY

PART NUMBERS				PART NUMBERS			
CANCELLED			NEW	CANCELLED			NEW
UNCOATED	PHOSPHATE	CAD or ZN	CADMIUM	UNCOATED	PHOSPHATE	CAD or ZN	CADMIUM
MS15795-1	MS15795-101	MS15795-201	MS27183-1	MS15795-21	MS15795-121	MS15795-221	MS27183-22
-2	-102	-202	-2	-22	-122	-222	-23
-3	-103	-203	-3	-23	-123	-223	-24
-4	-104	-204	-4	-24	-124	-224	-25
-5	-105	-205	-5	-25	-125	-225	-26
-6	-106	-206	-6	-26	-126	-226	-27
-7	-107	-207	-7	-27	-127	-227	-28
-8	-108	-208	-8	-28	-128	-228	-29
-9	-109	-209	-9	-29	-129	-229	-30
-10	-110	-210	-10	-30	-130	-230	-31
-11	-111	-211	-11	-31	-131	-231	-32
-12	-112	-212	-12	-32	-132	-232	-33
-13	-113	-213	-13	-33	-133	-233	-34
-14	-114	-214	-14	-34	-134	-234	-35
-15	-115	-215	-15	-35	-135	-235	-36
-16	-116	-216	-16	-36	-136	-236	-37
-17	-117	-217	-17	-37	-137	-237	-38
-18	-118	-218	-18	-38	-138	-238	-39
-19	-119	-219	-19	-39	-139	-239	-40
-20	-120	-220	-21	-40	-140		-20

## MILITARY INTERESTS

## CUSTODIANS

ARMY - AR  
NAVY - OS  
AIR FORCE - 82

## REVIEWER

ARMY - AV FR MI  
NAVY - AS SH MC  
NATIONAL SECURITY AGENCIES - N

## PREPARING ACTIVITY

DLA-15

(PROJECT 5310-2210)