

Low Voltage 5V DC Motor Driver

PRODUCT DESCRIPTION

The MS3111D is a low voltage 5V DC motor driver. It provides integrated motor driver solution for motion control applications such as camera, consumer product, toy or battery supply.

The MS3111D could provide up to 0.8A output current and operate from 1.8V~6V power supply.

The MS3111D has PWM (IN/IN) input interface, compatible with industry standard device, and also has thermal shutdown protection.

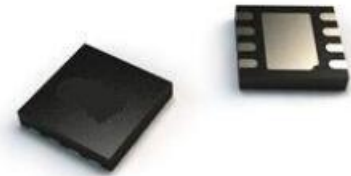

DFN8L

FEATURES

- H Bridge Motor Driver
 - Drive DC Motor or Other loads
 - Low On-Resistance(HS+LS) 850mΩ
- Drive Current: 0.8A
- Power Supply: 1.8V~6V
- Interface Type: PWM(IN1/IN2) Input Mode
- Thermal Shutdown Protection
- Low Current Sleep Mode

APPLICATIONS

- Camera
- Digital Single Lens Reflex (DSLR) Camera
- Consumer Product
- Toy
- Robot Technology
- Medical Device

PRODUCT SPECIFICATION

Part Number	Package	Marking
MS3111D	DFN8L	3111D

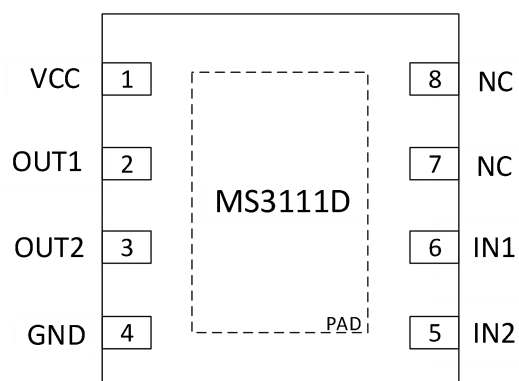
PIN CONFIGURATION

PIN DESCRIPTION

Pin	Name	Type	Description
1	VCC	-	Power Supply
2	OUT1	O	Output 1
3	OUT2	O	Output 2
4	GND	-	Ground
5	IN2	I	Input 2
6	IN1	I	Input 1
7	NC	-	Not Connection
8	NC	-	Not Connection
-	PAD	-	Thermal Pad, connect to ground

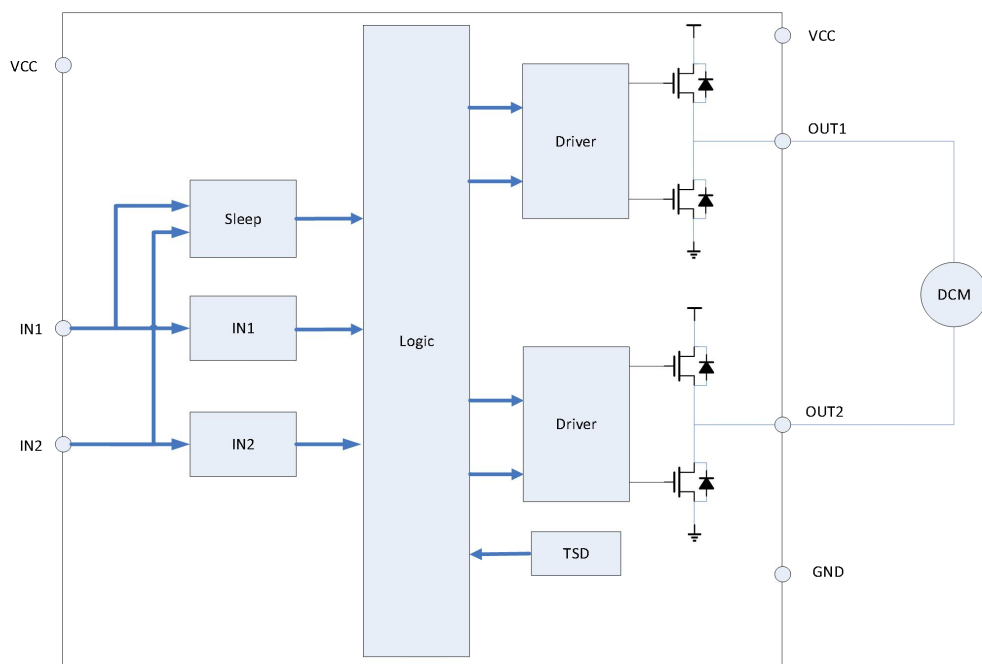
BLOCK DIAGRAM



ABSOLUTE MAXIMUM RATINGS

Any exceeding absolute maximum rating application causes permanent damage to device. Because long-time absolute operation state affects device reliability. Absolute ratings just conclude from a series of extreme tests. It doesn't represent chip can operate normally in these extreme conditions. T=25°C, unless otherwise noted.

Parameter	Symbol	Ratings	Unit
Supply Voltage	VCC	-0.3 ~ 6	V
Control Input Voltage	INX	-0.5 ~ 6	V
Drive Peak Current	I _{max}	0 ~ 1	A
Junction Temperature	T _{jmax}	-40 ~ 150	°C
Storage Temperature	T _{stg}	-60 ~ 150	°C
ESD(HBM)	ESD	±2500	V
Thermal Resistance, Junction to Package	R _{θjc}	63.64	°C/W

RECOMMENDED OPERATING CONDITIONS

Unless otherwise noted, T=25°C.

Parameter	Symbol	Condition	Min	Typ	Max	Unit
Logic Power Supply	VCC		1.8		6	V
Output Current	I _{OUT}		0		0.8	A
External PWM Frequency	f _{PWM}		0		250	kHz
Logical Input Voltage	V _{logic}		0		6	V
Operating Temperature	T _a		-40		85	°C

ELECTRICAL CHARACTERISTICS
Electrical Characteristics

Unless otherwise noted, T=25°C, VCC=5V.

Parameter	Symbol	Condition	Min	Typ	Max	Unit
VCC Operating Voltage	VCC		1.8		6	V
VCC Operating Current 1	I _{VCC}	VCC=5V, No PWM		100	550	uA
VCC Operating Current 2	I _{VCCQ}	VCC=5V, IN1=IN2='L'		0.01	1	uA
Output Module						
On-Resistance (HS+LS)	R _{dsON}	VCC=5V, I _o =500mA		850	1000	mΩ
Off-state Leakage Current	I _{OFF}	V _{out} =0V	-200		200	nA
Control Input Pin (IN1, IN2)						
Logical Input Low Voltage	V _{IL}		0		0.27×VCC	V
Logical Input High Voltage	V _{IH}		0.40×VCC		VCC	V
Input Hysteresis	V _{HY}			0.13×VCC		mV
Logical Input Low Current	I _{IL}	V _{in} =0	-5		5	uA
Logical Input High Current	I _{IH}	V _{in} =3.3V			50	uA
Pull-down Resistance	R _{pd}			100		kΩ
Protection Circuit						
Thermal Shutdown	TSD		150	160	180	°C
Thermal Shutdown Hysteresis	ΔTSD			20		°C

Timing

TA=25°C, VCC=5V, RL=20Ω.

Parameter		Range		Unit
		Min	Max	
t1	Start Time		100	us
t2	Shutdown Time		300	ns
t3	Input High to Output High		160	ns
t4	Input Low to Output Low		160	ns
t5	Output Rising Edge	30	188	ns
t6	Output Falling Edge	30	188	ns

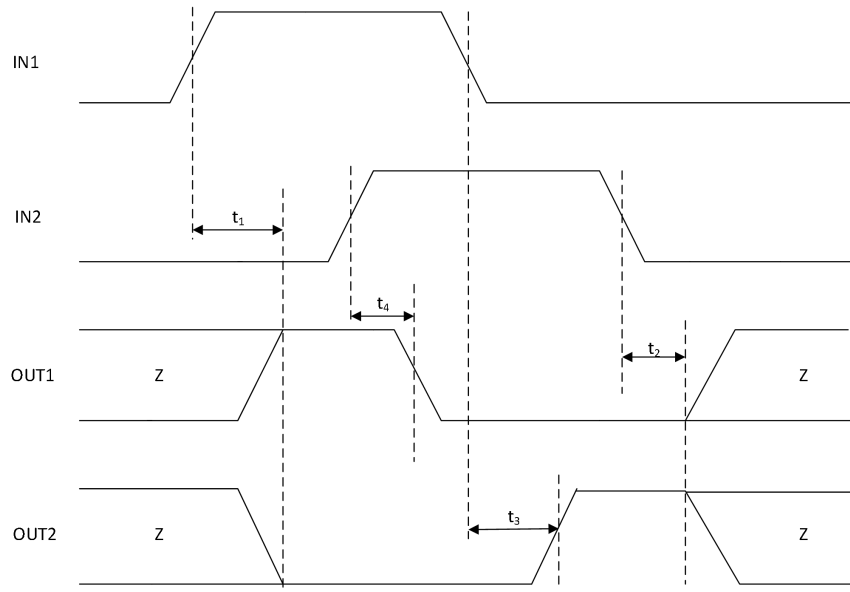

Figure 1. MS3111D Input and Output Time Parameter 1

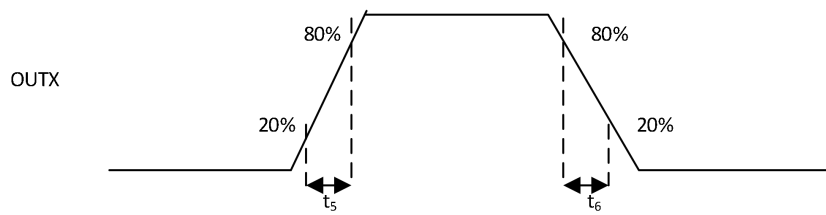

Figure 2. MS3111D Input and Output Time Parameter 2

FUNCTION DESCRIPTION

Bridge Control

The MS3111D is controlled By PWM input interface, which is also called IN/IN input mode. The control truth table is as follows.

IN1	IN2	OUT1	OUT2	Function
0	0	Z	Z	Rotate Free
0	1	L	H	Reverse
1	0	H	L	Forward
1	1	L	L	Brake

Sleep Mode

When IN1 and IN2 are all low level at the same time, the MS3111D enters sleep mode with low dissipation. Most internal circuits stop working, output is in high-impedance state and motor rotates free.

Input Pin

The default state of input pin is low level with 100kΩ pull-down resistor.

In application, it is necessary to connect 0.1uF ceramic capacitor with VCC to ground, and as close to the chip as possible.

Thermal Shutdown

When the junction temperature exceeds 160°C, thermal shutdown circuit would be activated and all outputs would be off. When the temperature drops one hysteresis temperature 20°C and then reaches 140°C, all outputs recovery working.

However, thermal shutdown protection just acts when the junction temperature exceeds the setting. Therefore, it couldn't ensure the device against being destroyed.

Failure	Condition	H Bridge	Recovery
Thermal Shutdown	$T_j > 160^\circ\text{C}$	Off	$T_j < 140^\circ\text{C}$

TYPICAL APPLICATION DIAGRAM

Figure 3. Typical Application Diagram of the MS3111D

- In any condition, the parameter can't exceed absolute maximum rating.
- The bypass capacitor of VCC, especially ceramic capacitor, should be as close to VCC pin as possible.
- It's necessary to isolate ground traces connected with motor in layout design.

PACKAGE OUTLINE DIMENSIONS
DFNWB2X2-8L (P0.5T0.75/0.85)

Symbol	Dimensions In Millimeters		
	Min	Typ	Max
A	0.70	0.75	0.80
A1	-	0.02	0.05
b	0.18	0.25	0.30
c	0.18	0.20	0.25
D	1.90	2.00	2.10
D2	1.10	1.20	1.30
e	0.50BSC		
Nd	1.50BSC		
E	1.90	2.00	2.10
E2	0.60	0.70	0.80
L	0.30	0.35	0.40
h	0.15	0.20	0.25
Carrier Size (mil)	63×39		

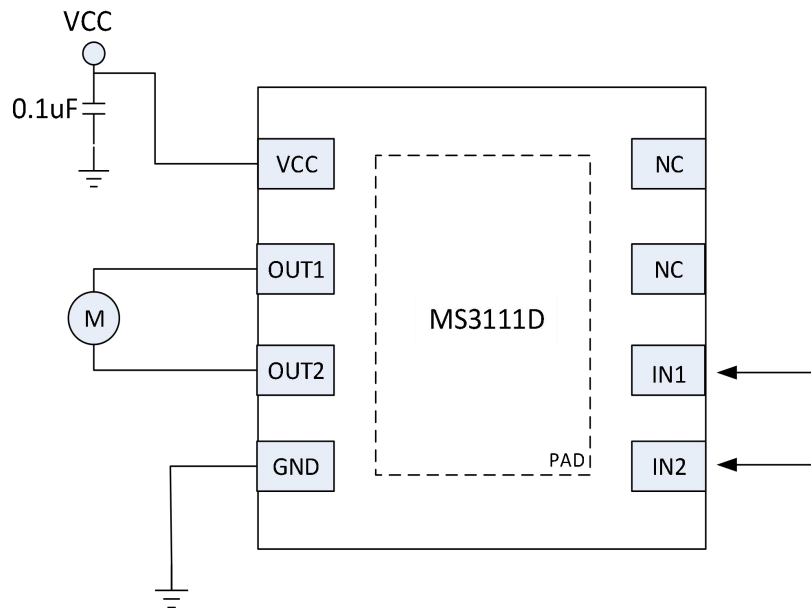
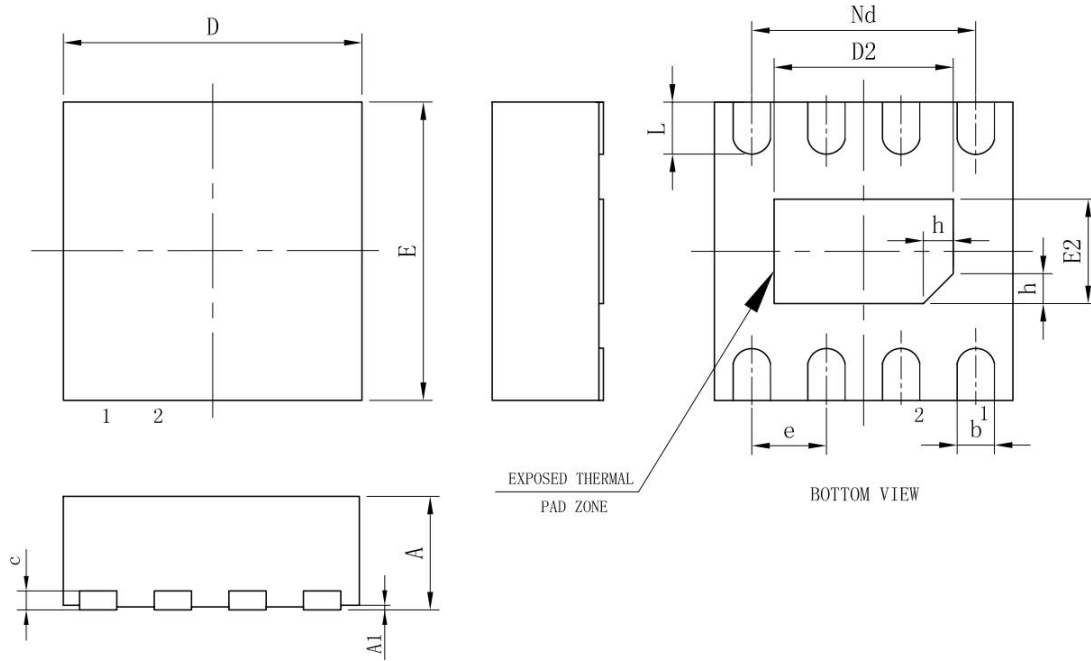
MARKING and PACKAGING SPECIFICATIONS

1. Marking Drawing Description

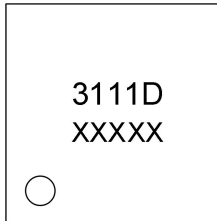

Product Name: 3111D

Product Code: XXXXX

2. Marking Drawing Demand

Laser printing, contents in the middle, font type Arial.

3. Packaging Specifications

Device	Package	Piece/Reel	Reel/Box	Piece /Box	Box/Carton	Piece/Carton
MS3111D	DFN8L	3000	10	30000	4	120000

STATEMENT

- All Revision Rights of Datasheets Reserved for Ruimeng. Don't release additional notice.
Customer should get latest version information and verify the integrity before placing order.
- When using Ruimeng products to design and produce, purchaser has the responsibility to observe safety standard and adopt corresponding precautions, in order to avoid personal injury and property loss caused by potential failure risk.
- The process of improving product is endless. And our company would sincerely provide more excellent product for customer.



MOS CIRCUIT OPERATION PRECAUTIONS

Static electricity can be generated in many places. The following precautions can be taken to effectively prevent the damage of MOS circuit caused by electrostatic discharge:

1. The operator shall ground through the anti-static wristband.
2. The equipment shell must be grounded.
3. The tools used in the assembly process must be grounded.
4. Must use conductor packaging or anti-static materials packaging or transportation.



+86-571-89966911



Rm701, No.9 Building, No. 1 WeiYe Road, Puyan Street, Binjiang District, Hangzhou, Zhejiang



[http:// www.relmon.com](http://www.relmon.com)