





32MB SDRAM DIMM

MS3416L464S-08

4Mb x 64, 168-Pin DIMM
3.3V Synchronous DRAMs with SPD

FRONT VIEW

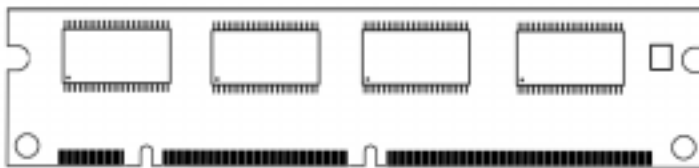

BACK VIEW

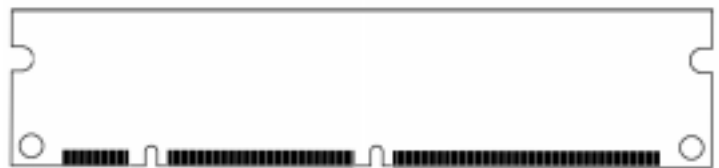

GENERAL DESCRIPTION

The Macrotron MS3416L464S-08 is a PC100 Compliant 4M bit x 64 bit Synchronous Dynamic RAM high density memory module. It consists of four CMOS 4M x 16 bit with Synchronous DRAMs in TSOP packages and a 2K EEPROM in 8-pin TSOP package on a 168-pin glass-epoxy substrate. Decoupling capacitors are mounted on the printed circuit board in parallel for each SDRAM. The product is a Dual In-line Memory Module and is intended for mounting into 168-pin edge connector sockets.

Synchronous design allows precise cycle controls with the use of system clock. I/O transactions are possible on every clock cycle. Range of operating frequencies and programmable latencies allow the same device to be useful for a variety of high bandwidth, high performance memory system applications.

FEATURES

- 8 Megabit by 64 bit (64 Megabyte) Synchronous DRAM Module PC 100 Compliant
- JEDEC-standard 168-pin, dual in-line memory module (DIMM)
- Utilizes 8ns SDRAM components
- Nonbuffered
- Single +3.3V \pm 0.3V power supply
- Fully synchronous; all signals registered on positive edge system clock
- Internal pipeline operation; column address can be changed every clock cycle
- Dual internal banks for hiding row access/precharge
- Programmable burst lengths: 1,2,4, 8 or full page
- Auto Precharged and Auto Refresh Modes
- LVTTTL compatible inputs and outputs
- Serial Presence Detect (SPD)

PART NUMBER DESIGNATOR

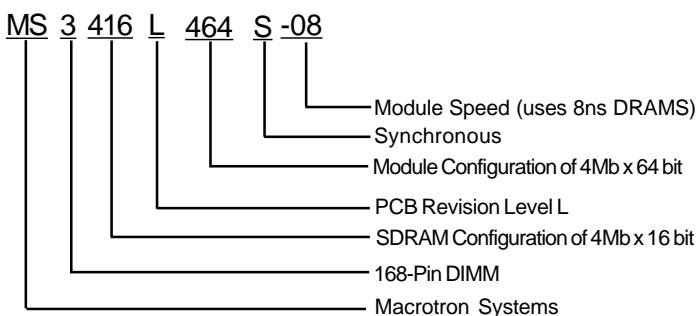

KEY TIMING PARAMETERS

PARAMETER	VALUE	UNIT
Module Bus Speed	100	MHz
Module Speed	8.0	ns
SDRAM Speed	125	MHz
CAS Latency	2/3	CLOCK
SDRAM Access Time	6.0	ns
SDRAM Setup Time	2.0	ns
SDRAM Hold Time	1.0	ns



32MB SDRAM DIMM

MS3416L464S-08

4Mb x 64, 168-Pin DIMM
3.3V Synchronous DRAMs with SPD

PIN CONFIGURATIONS

PIN	FRONT	PIN	BACK	PIN	FRONT	PIN	BACK	PIN	FRONT	PIN	BACK
1	V _{SS}	29	DQMB1	57	DQ18	85	V _{SS}	113	DQMB5	141	DQ50
2	DQ0	30	CS0	58	DQ19	86	DQ32	114	*CS1	142	DQ51
3	DQ1	31	DU	59	V _{DD}	87	DQ33	115	RAS	143	V _{DD}
4	DQ2	32	V _{SS}	60	DQ20	88	DQ34	116	V _{SS}	144	DQ52
5	DQ3	33	A0	61	NC	89	DQ35	117	A1	145	NC
6	V _{DD}	34	A2	62	*VREF	90	V _{DD}	118	A3	146	*VREF
7	DQ4	35	A4	63	*CKE1	91	DQ36	119	A5	147	NC
8	DQ5	36	A6	64	V _{SS}	92	DQ37	120	A7	148	V _{SS}
9	DQ6	37	A8	65	DQ21	93	DQ38	121	A9	149	DQ53
10	DQ7	38	A10/AP	66	DQ22	94	DQ39	122	BA0	150	DQ54
11	DQ8	39	BA1	67	DQ23	95	DQ40	123	A11	151	DQ55
12	V _{SS}	40	V _{DD}	68	V _{SS}	96	V _{SS}	124	V _{DD}	152	V _{SS}
13	DQ9	41	V _{DD}	69	DQ24	97	DQ41	125	*CLK1	153	DQ56
14	DQ10	42	CLK0	70	DQ25	98	DQ42	126	*A12	154	DQ57
15	DQ11	43	V _{SS}	71	DQ26	99	DQ43	127	V _{SS}	155	DQ58
16	DQ12	44	DU	72	DQ27	100	DQ44	128	CKE0	156	DQ59
17	DQ13	45	DS2	73	V _{DD}	101	DQ45	129	*CS3	157	V _{DD}
18	V _{DD}	46	DQMB2	74	DQ28	102	V _{DD}	130	DQMB6	158	DQ60
19	DQ14	47	DQMB3	75	DQ29	103	DQ46	131	DQMB7	159	DQ61
20	DQ15	48	DU	76	DQ30	104	DQ47	132	*A13	160	DQ62
21	*CBO	49	V _{DD}	77	DQ31	105	*CB4	133	V _{DD}	161	DQ63
22	*CB1	50	NC	78	V _{SS}	106	*CB5	134	NC	162	V _{SS}
23	V _{SS}	51	NC	79	CLK2	107	V _{SS}	135	NC	163	CLK3
24	NC	52	*CB2	80	NC	108	NC	136	*CB6	164	NC
25	NC	53	*CB3	81	WP	109	NC	137	*CB7	165	**SA0
26	V _{DD}	54	V _{SS}	82	**SDA	110	V _{DD}	138	V _{SS}	166	**SA1
27	WE	55	DQ16	83	**SCL	111	CAS	139	DQ48	167	**SA2
28	DQMB0	56	DQ17	84	V _{DD}	112	DQMB4	140	DQ49	168	V _{DD}

PIN NAMES

PIN NAME	FUNCTION
A0~A13	Address Input (multiplexed)
BA0~BA1	Select Bank
DQ0~DQ63	Data Input / Data Output
CLK0~CLK3	Clock Input
CKE0~CKE1	Clock Enable Input
CS0~CS3	Chip Select Input
RAS	Row Address Strobe
CAS	Column Address Strobe
WE	Write Enable
DQMB0~7	DQMB
VDD	Power Supply (3.3V)
VSS	Ground
VREF	Power Supply for Reference
SDA	Serial Data I/O
SCL	Serial Clock
SA0~2	Address in EEPROM
DU	Don't Use
NC	No Connection
AP	Automatic Precharge
WP	Write Protection

* These pins are not used in this module.

** These pins should be NC in the system which does not support SPD.

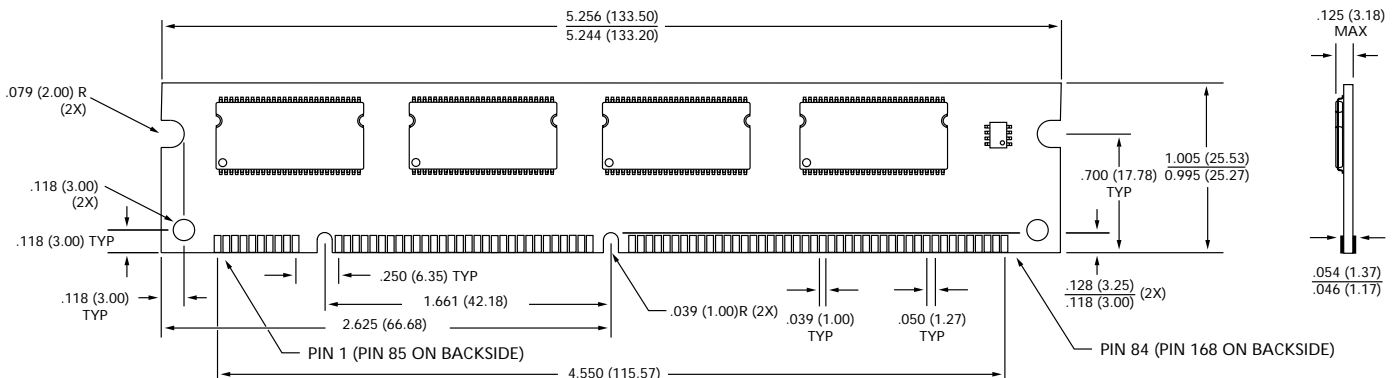



MACROTRON

32MB SDRAM DIMM

MS3416L464S-08

4Mb x 64, 168-Pin DIMM
3.3V Synchronous DRAMs with SPD

ABSOLUTE MAXIMUM RATINGS

PARAMETERS	SYMBOL	VALUE	UNIT
Voltage on any pin relative to V_{SS}	V_{IN}, V_{OUT}	-1.0 ~ 4.6	V
Voltage on V_{DD} supply relative to V_{SS}	V_{DD}, V_{DDQ}	-1.0 ~ 4.6	V
Storage Temperature	T_{STG}	-55 ~ +150	C
Power Dissipation	PD	8	W
Short Circuit Current	I_{OS}	50	mA

DC OPERATING CONDITIONS AND CHARACTERISTICS

PARAMETERS	SYMBOL	MIN	MAX	UNIT	NOTES	
Supply Voltage	V_{DD}	3.0	3.6	V		
Input High Voltage (Logic 1), All Inputs	V_{IH}	2.0	$V_{DD} + 0.3$	V		
Input low Voltage (Logic 0), All Inputs	V_{IL}	-0.3	0.8	V		
INPUT LEAKAGE CURRENT Any input $0V \leq V_{IN} \leq V_{DD}$ (All other pins not under test = 0V)	DQMB0~DQMB7	I_{I1}	-5	5	μA	
	CLK0~2, CS0~2#	I_{I2}	-10	10	μA	
	CKE0~1	I_{I3}	-20	20	μA	
	RAS, CAS, A0~A11, BA0~1, WE	I_{I4}	-20	20	μA	
OUTPUT LEAKAGE CURRENT (DQs are disabled; $0V \leq V_{OUT} \leq V_{DD}$)	DQ0~DQ63	I_{OZ}	-5	5	μA	
OUTPUT LEVELS						
Output High Voltage	V_{OH}	2.4			$I_{OH} = -2mA$	
Output low Voltage	V_{OL}		0.4	V	$I_{OL} = 2mA$	

CAPACITANCE ($V_{DD} = 3.3V, T_A = 23C, F = 1MHZ, V_{REF} = 1.4V$)

PARAMETERS	SYMBOL	MAX	UNIT
Input Capacitance ($A_0 \sim A_n, BA0\sim 1, RAS, CAS, WE$)	C_{I1}	18	pF
Input Capacitance (CS0~2#)	C_{I2}	10	pF
Input Capacitance (CKE0~1)	C_{I3}	18	pF
Input Capacitance (DQMB0~7)	C_{I4}	6	pF
Input Capacitance (SCL, SA0-2, SDA, WP)	C_{I5}	10	pF
Data Input/Output Capacitance (DQ0~63)	C_{I0}	8	pF
Input Capacitance (CLK0~3)	C_{I6}	29	pF



32MB SDRAM DIMM

MS3416L464S-08

4Mb x 64, 168-Pin DIMM
3.3V Synchronous DRAMs with SPD

OPERATING CONDITIONS AND MAXIMUM LIMITS

PARAMETER/CONDITION	SYMBOL	MAX	UNITS
OPERATING CURRENT: Active Mode, Burst =2 READ or WRITE, $t_{RC} \geq t_{RC} (MIN)$, CAS Latency = 3	ICC1	460	mA
STANDBY CURRENT: Power-Down Mode, $t_{CK} = 10ns$, $CKE \leq V_{IL} (MAX)$, All banks idle	ICC2	16	mA
STANDBY CURRENT: $CS \geq V_{IH} (MIN)$, $t_{CK} = 10ns$, $CKE \geq V_{IH} (MAX)$, All banks idle	ICC3	48	mA
STANDBY CURRENT: $CS \geq V_{IH} (MIN)$ $t_{CK} = 10ns$, $CKE \geq V_{IH} (MIN)$, all banks active after t_{RCD} met, No accesses in progress	ICC4	180	mA
OPERATING CURRENT: Burst Mode, Continuous burst, READ or WRITE, $t_{CK} = 10ns$, all banks active, Addresses transition once per clock cycle, CAS Latency = 3	ICC5	560	mA
AUTO REFRESH CURRENT: $t_{RC} > t_{RC} (MIN)$, CAS Latency = 3	ICC6	840	mA
SELF REFRESH CURRENT: $CKE < 0.2V$	ICC7	4	mA

DataSheet4U.com

AC FUNCTIONAL CHARACTERISTICS

PARAMETERS		SYMBOL		UNITS
READ/WRITE command to READ/WRITE command		tCCD	1	tCK
CKE to clock disable or power-down entry mode		tCKED	1	tCK
CKE to clock enable or power-down exit mode		tPED	1	tCK
DQM to input data delay		tDQD	0	tCK
DQM to data mask during WRITES		tDQM	0	tCK
DQM to data high-impedance during READS		tDQZ	2	tCK
WRITE command to input data delay		tDWD	0	tCK
Data-in to PRECHARGE command		tDAL	2	tCK
Data-in to ACTIVE command		tDPL	5	tCK
Last data-in to PRECHARGE command		tRDL	2	tCK
Last data-in to burst STOP command		tBDL	1	tCK
Last data-in to new READ/WRITE command		tCDL	1	tCK
LOAD MODE REGISTER command to command		tMRD	2	tCK
Data-out to high-impedance from PRECHARGE command	CAS latency=3	tROH	3	tCK
	CAS latency=2	tROH	2	tCK

FUNCTIONAL BLOCK DIAGRAM

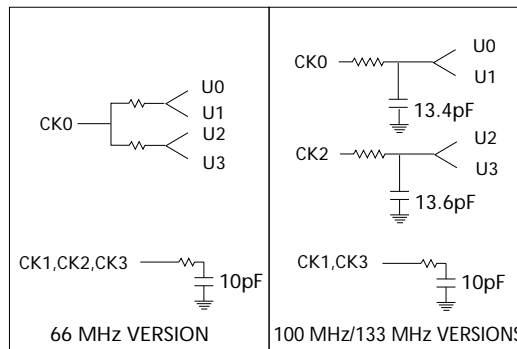
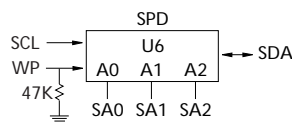
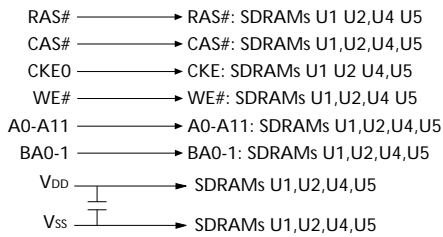
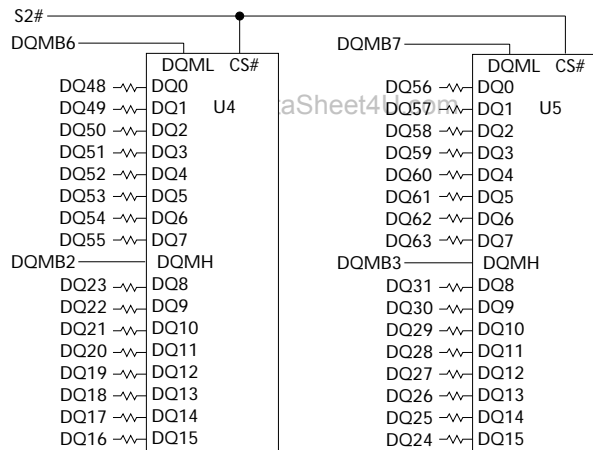
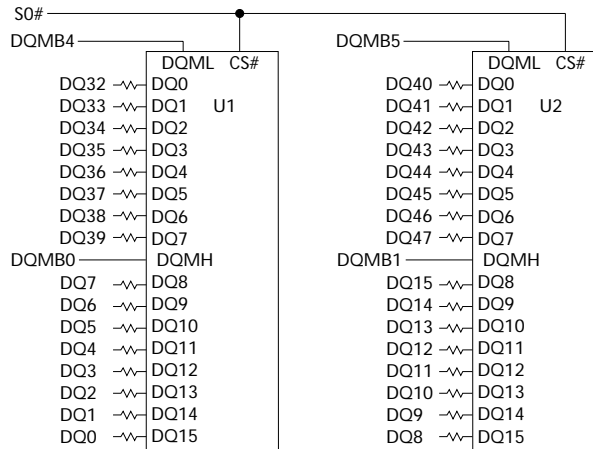

U1, U2, U4, U5 = MT48LC4M16A2TG SDRAMs for 32MB