

Operation Manual

ShockLine™

MS46122A Series

Compact Vector Network Analyzer

MS46122A-010 VNA, 1 MHz to 8 GHz, 2-Port

MS46122A-020 VNA, 1 MHz to 20 GHz, 2-Port

MS46122A-040 VNA, 1 MHz to 40 GHz, 2-Port



Anritsu

WARRANTY

The Anritsu product(s) listed on the title page is (are) warranted against defects in materials and workmanship for three (3) years from the date of shipment.

Anritsu's obligation covers repairing or replacing products which prove to be defective during the warranty period. Buyers shall prepay transportation charges for equipment returned to Anritsu for warranty repairs. Obligation is limited to the original purchaser. Anritsu is not liable for consequential damages.

LIMITATION OF WARRANTY

The foregoing warranty does not apply to Anritsu connectors that have failed due to normal wear. Also, the warranty does not apply to defects resulting from improper or inadequate maintenance, unauthorized modification or misuse, or operation outside of the environmental specifications of the product. No other warranty is expressed or implied, and the remedies provided herein are the Buyer's sole and exclusive remedies.

DISCLAIMER OF WARRANTY

DISCLAIMER OF WARRANTIES. TO THE MAXIMUM EXTENT PERMITTED BY APPLICABLE LAW, ANRITSU COMPANY AND ITS SUPPLIERS DISCLAIM ALL WARRANTIES, EITHER EXPRESSED OR IMPLIED, INCLUDING, BUT NOT LIMITED TO, IMPLIED WARRANTIES OF MERCHANTABILITY AND FITNESS FOR A PARTICULAR PURPOSE, WITH REGARD TO THE PRODUCT. THE USER ASSUMES THE ENTIRE RISK OF USING THE PRODUCT. ANY LIABILITY OF PROVIDER OR MANUFACTURER WILL BE LIMITED EXCLUSIVELY TO PRODUCT REPLACEMENT.

NO LIABILITY FOR CONSEQUENTIAL DAMAGES. TO THE MAXIMUM EXTENT PERMITTED BY APPLICABLE LAW, IN NO EVENT SHALL ANRITSU COMPANY OR ITS SUPPLIERS BE LIABLE FOR ANY SPECIAL, INCIDENTAL, INDIRECT, OR CONSEQUENTIAL DAMAGES WHATSOEVER (INCLUDING, WITHOUT LIMITATION, DAMAGES FOR LOSS OF BUSINESS PROFITS, BUSINESS INTERRUPTION, LOSS OF BUSINESS INFORMATION, OR ANY OTHER PECUNIARY LOSS) ARISING OUT OF THE USE OF OR INABILITY TO USE THE PRODUCT, EVEN IF ANRITSU COMPANY HAS BEEN ADVISED OF THE POSSIBILITY OF SUCH DAMAGES. BECAUSE SOME STATES AND JURISDICTIONS DO NOT ALLOW THE EXCLUSION OR LIMITATION OF LIABILITY FOR CONSEQUENTIAL OR INCIDENTAL DAMAGES, THE ABOVE LIMITATION MAY NOT APPLY TO YOU.

TRADEMARK ACKNOWLEDGMENTS

Anritsu, ShockLine, and K Connector are trademarks of Anritsu Company, Morgan Hill, California, USA.

Acrobat Reader is a registered trademark of Adobe Corporation of San Jose, California, USA.

Hampshire is a registered trademark and TSHARC a trademark of Microchip Technology, Chandler, Arizona, USA.

NI is a registered trademark of the National Instruments Corporation, Austin, Texas, USA.

Smith (Smith Chart) is a registered trademark of Analog Instruments Company, New Providence, New Jersey, USA.

Teflon is a registered trademark and brand name of the DuPont Company.

Windows, Windows 7, Windows 8, and ToolTips are registered trademarks of Microsoft Corporation, Redmond, Washington, USA.

All other trademarks mentioned are the property of their respective companies.

NOTICE

Anritsu Company has prepared this manual for use by Anritsu Company personnel and customers as a guide for the proper installation, operation and maintenance of Anritsu Company equipment and computer programs. The drawings, specifications, and information contained herein are the property of Anritsu Company, and any unauthorized use or disclosure of these drawings, specifications, and information is prohibited; they shall not be reproduced, copied, or used in whole or in part as the basis for manufacture or sale of the equipment or software programs without the prior written consent of Anritsu Company.

UPDATES

Updates, if any, can be downloaded from the Documents area of the Anritsu Website at:

<http://www.anritsu.com>

For the latest service and sales contact information in your area, please visit:

<http://www.anritsu.com/contact.asp>

ANRITSU COMPANY SOFTWARE LICENSE AGREEMENT

IMPORTANT-READ CAREFULLY BEFORE OPENING THE SOFTWARE PACKET. BY OPENING THE PACKET CONTAINING THE SOFTWARE, YOU ARE AGREEING TO BE BOUND BY THE TERMS OF THIS AGREEMENT. THIS IS A LEGAL AGREEMENT BETWEEN YOURSELF, AND YOUR EMPLOYER, IF APPLICABLE, AND ANRITSU COMPANY ("ACUS"). IF YOU DO NOT AGREE WITH ALL OF THE TERMS OF THIS AGREEMENT, PROMPTLY RETURN THE UNOPENED SOFTWARE PACKAGE, AND THE ACCOMPANYING DOCUMENTATION TO ANRITSU FOR FULL CREDIT.

SOFTWARE LICENSE AGREEMENT

1. **GRANT OF LICENSE.** This License Agreement permits you to use one copy of the enclosed software program (the "Software") on a single computer (unless you have purchased a multiple test license to run on a dedicated client/server for a specified number of workstations). If you have a multi user license for the Software, then at any time you may use as many copies of the Software in use as are permitted by the multi user license. The SOFTWARE is in use on a computer when it is loaded into temporary memory (i.e. RAM), installed into permanent memory (i.e. hard disk, CD-ROM, or other storage device), or installed/ loaded into any appropriate ACUS product. If the anticipated number of users of the SOFTWARE could exceed the number of users permitted by applicable licenses, then you must have a reasonable mechanism or process in place to ensure that the number of persons using the SOFTWARE does not exceed the number permitted by the applicable license. All rights not expressly granted are reserved to ACUS. This Grant of License is not subject to transfer or assignment by Licensee.

2. **COPYRIGHT.** This SOFTWARE is owned by ACUS and is protected by United States copyright laws and international treaty provisions. Furthermore, it is considered by ACUS to be ACUS proprietary information. Therefore, you must treat the SOFTWARE like any other copyrighted or proprietary material except that you may either (a) make one copy of the SOFTWARE solely for backup or archival purposes, or (b) transfer the SOFTWARE to a single hard disk, provided you keep the original solely for backup or archival purposes. You may NOT copy any written documentation accompanying the SOFTWARE.

3. **OTHER RESTRICTIONS.** You may not reverse engineer, decompile, or disassemble the SOFTWARE, nor may you publish the SOFTWARE on the internet, or load the SOFTWARE onto your company's network.

4. **WARRANTY.** ACUS warrants for a period of one (1) year from date of delivery that the SOFTWARE will, unless modified, perform the functions described in the accompanying documentation. ACUS's sole obligation is to undertake to correct or replace any reported error conditions.

ACUS DOES NOT WARRANT THAT THE SOFTWARE WILL RUN PROPERLY ON ALL HARDWARE, THAT THE SOFTWARE WILL MEET LICENSEES REQUIREMENTS, OR THAT ALL SOFTWARE ERRORS WILL BE CORRECTED. THE WARRANTIES ABOVE ARE EXCLUSIVE AND IN LIEU OF ALL OTHER WARRANTIES, WHETHER EXPRESSED OR IMPLIED, INCLUDING THE IMPLIED WARRANTY OF MERCHANTABILITY OR FITNESS FOR A PARTICULAR PURPOSE. ACUS SHALL NOT BE LIABLE FOR DIRECT, INDIRECT, INCIDENTAL, SPECIAL, OR CONSEQUENTIAL DAMAGES, OR DAMAGES FOR LOSS OF PROFITS, REVENUE, DATA, OR USE, INCURRED BY licensee, REGARDLESS OF WHETHER IN TORT OR CONTRACT, AND REGARDLESS OF WHETHER LICENSEE HAS ADVISED ACUS OF THE POSSIBILITY OF SUCH LOSSES.

5. **EXPORT CONTROL.** Licensee shall not export or re-export software technical data, goods, or information licensed by ACUS directly or through others, to the proscribed countries, or foreign nationals of those countries, and/or denied parties, in violation of any applicable U.S., U.K., Danish, or Japanese export control laws and regulations or any other applicable export control laws promulgated and administered by the government of any country having jurisdiction over the parties or transaction.

6. **TERMINATION.** Any breach of the terms or conditions of this Grant of License will result in termination of the license granted hereunder. Upon termination of the license granted hereunder, Licensee shall return all copies of the software to ACUS, or certify their destruction in writing.

7. **GOVERNING LAW.** This agreement, and all of the rights hereunder, shall be interpreted and determined by the laws of the State of California, and all disputes shall be subject to the jurisdiction of the Courts within the State of California.

DECLARATION OF CONFORMITY

Manufacturer's Name: ANRITSU COMPANY

Manufacturer's Address: Microwave Measurements Division
490 Jarvis Drive
Morgan Hill, CA 95037-2809
USA

declares that the product specified below:

Product Name: Compact ShockLine VNA

Model Number: MS461XXA

conforms to the requirement of:

EMC Directive: 2004/108/EC
Low Voltage Directive: 2006/95/EC

Electromagnetic Compatibility: EN61326-1:2006

Emissions: EN55011:2009 +A1:2010 Group 1 Class A

Immunity:	EN 61000-4-2:2009	4 kV CD, 8 kV AD
	EN 61000-4-3:2006 +A2:2010	3 V/m
	EN 61000-4-4:2004	0.5 kV S-L, 1 kV P-L
	EN 61000-4-5:2006	0.5 kV L-L, 1 kV L-E
	EN 61000-4-6: 2009	3 V
	EN 61000-4-11: 2004	100% @ 20 ms

Electrical Safety Requirement:

Product Safety: EN 61010-1:2010

Morgan Hill, CA

Eric McLean, Corporate Quality Director

17 Sept 2014
Date

Notes On Export Management

This product and its manuals may require an Export License or approval by the government of the product country of origin for re-export from your country.

Before you export this product or any of its manuals, please contact Anritsu Company to confirm whether or not these items are export-controlled.

When disposing of export-controlled items, the products and manuals need to be broken or shredded to such a degree that they cannot be unlawfully used for military purposes.

CE Conformity Marking

Anritsu affixes the CE Conformity marking onto its conforming products in accordance with Council Directives of The Council Of The European Communities in order to indicate that these products conform to the EMC and LVD directive of the European Union (EU).



C-tick Conformity Marking

Anritsu affixes the C-tick marking onto its conforming products in accordance with the electromagnetic compliance regulations of Australia and New Zealand in order to indicate that these products conform to the EMC regulations of Australia and New Zealand.



European Parliament and Council Directive 2002/96/EC

Equipment Marked with the crossed-out Wheelie Bin symbol complies with the European Parliament and Council Directive 2002/96/EC (the "WEEE Directive") in the European Union.

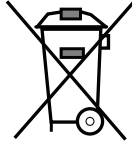

For Products placed on the EU market after August 13, 2005, please contact your local Anritsu representative at the end of the product's useful life to arrange disposal in accordance with your initial contract and the local law.

Chinese RoHS Compliance Statement

产品中有毒有害物质或元素的名称及含量

For Chinese Customers Only NLNB

部件名称	有毒有害物质或元素					
	铅 (Pb)	汞 (Hg)	镉 (Cd)	六价铬 [Cr(VI)]	多溴联苯 (PBB)	多溴二苯醚 (PBDE)
印刷线路板 (PCA)	×	○	×	×	○	○
机壳、支架 (Chassis)	×	○	×	×	○	○
其他(电缆、风扇、 连接器等) (Appended goods)	×	○	×	×	○	○

○：表示该有毒有害物质在该部件所有均质材料中的含量均在 SJ/T11363-2006 标准规定的限量要求以下。
 ×：表示该有毒有害物质至少在该部件的某一均质材料中的含量超出 SJ/T11363-2006 标准规定的限量要求。

环保使用期限



这个标记是根据 2006/2/28 公布的「电子信息产品污染控制管理办法」以及 SJ/T 11364-2006 「电子信息产品污染控制标识要求」的规定，适用于在中国销售的电子信息产品的环保使用期限。仅限于在遵守该产品的安全规范及使用注意事项的基础上，从生产日起算的该年限内，不会因产品所含有害物质的泄漏或突发性变异，而对环境污染，人身及财产产生深刻地影响。

注) 生产日期标于产品序号的前四码(如 S/N 0728XXXX 为 07 年第 28 周生产)。

Safety Symbols

To prevent the risk of personal injury or loss related to equipment malfunction, Anritsu Company uses the following symbols to indicate safety-related information. For your own safety, please read the information carefully *before* operating the equipment.

Symbols Used in Manuals

Danger



This indicates a risk from a very dangerous condition or procedure that could result in serious injury or death and possible loss related to equipment malfunction. Follow all precautions and procedures to minimize this risk.

Warning



This indicates a risk from a hazardous condition or procedure that could result in light-to-severe injury or loss related to equipment malfunction. Follow all precautions and procedures to minimize this risk.

Caution



This indicates a risk from a hazardous procedure that could result in loss related to equipment malfunction. Follow all precautions and procedures to minimize this risk.

Safety Symbols Used on Equipment and in Manuals

The following safety symbols are used inside or on the equipment near operation locations to provide information about safety items and operation precautions. Ensure that you clearly understand the meanings of the symbols and take the necessary precautions *before* operating the equipment. Some or all of the following five symbols may or may not be used on all Anritsu equipment. In addition, there may be other labels attached to products that are not shown in the diagrams in this manual.



This indicates a prohibited operation. The prohibited operation is indicated symbolically in or near the barred circle.



This indicates a compulsory safety precaution. The required operation is indicated symbolically in or near the circle.



This indicates a warning or caution. The contents are indicated symbolically in or near the triangle.



This indicates a note. The contents are described in the box.



These indicate that the marked part should be recycled.

For Safety

Warning



Always refer to the operation manual when working near locations at which the alert mark, shown on the left, is attached. If the operation, etc., is performed without heeding the advice in the operation manual, there is a risk of personal injury. In addition, the equipment performance may be reduced.

Moreover, this alert mark is sometimes used with other marks and descriptions indicating other dangers.

Warning

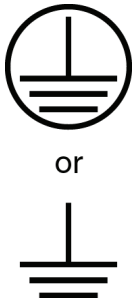

When supplying power to this equipment, connect the accessory 3-pin power cord to a 3-pin grounded power outlet. If a grounded 3-pin outlet is not available, use a conversion adapter and ground the green wire, or connect the frame ground on the rear panel of the equipment to ground. If power is supplied without grounding the equipment, there is a risk of receiving a severe or fatal electric shock.

Warning



This equipment can not be repaired by the operator. Do not attempt to remove the equipment covers or to disassemble internal components. Only qualified service technicians with a knowledge of electrical fire and shock hazards should service this equipment. There are high-voltage parts in this equipment presenting a risk of severe injury or fatal electric shock to untrained personnel. In addition, there is a risk of damage to precision components.

Caution



Electrostatic Discharge (ESD) can damage the highly sensitive circuits in the instrument. ESD is most likely to occur as test devices are being connected to, or disconnected from, the instrument's front and rear panel ports and connectors. You can protect the instrument and test devices by wearing a static-discharge wristband. Alternatively, you can ground yourself to discharge any static charge by touching the outer chassis of the grounded instrument before touching the instrument's front and rear panel ports and connectors. Avoid touching the test port center conductors unless you are properly grounded and have eliminated the possibility of static discharge.

Repair of damage that is found to be caused by electrostatic discharge is not covered under warranty.

Chapter Descriptions

Chapter 1 — Overview

This chapter provides an overview of the ShockLine MS46122A Series Vector Network Analyzer (VNA) and a description of its major functions and available documentation. A summary of available precision component kits including mechanical calibration kits and verification kits is included.

Chapter 2 — Installation

This chapter provides information for the initial inspection and preparation for use of the ShockLine MS46122A Series VNA and includes information on instrument installation, loading ShockLine Software, required operating environment, power requirements, and initial inspection. After power up, the various power modes are described with general warm-up and calibration time intervals. The preventive maintenance section includes information on cleaning along with preparation for storage or shipment.

Chapter 3 — Front and Rear Panels

The chapter provides an overview of the MS46122A Series VNA hardware user interface including front panel buttons and front panel connectors. Included are photographs of the front and rear panels. Each port and connector is described with its connector type, its function, input/output limits, and a cross-reference to a detailed connector pin-out diagram.

Chapter 4 — User Interface Display

The chapter describes the general display options of the ShockLine MS46122A Series VNA and provides a general description of the MENU BAR, the ICON TOOLBAR, and the right-side function menus. General descriptions and procedures are provided for trace graph setup, marker setup, and limit line setup.

Appendix A — Vector Network Analyzer Primer

This chapter describes the basic functions of a Vector Network Analyzer (VNA) and how it measures magnitude and phase characteristics of networks, amplifiers, attenuators, and antennas. Scattering parameters (S-parameters) are defined.

Appendix B — Maintenance and Security

Appendix C — Abbreviation Glossary

This glossary defines the abbreviations and terms that appear on the connectors and buttons of the MS46122A Series VNA. In some cases, due to space limitations, multiple abbreviations are used for the same term or the same abbreviation is used with different punctuation.

Table of Contents

Chapter 1 — Overview

1-1 Introduction	1-1
1-2 ShockLine MS46122A Series VNA Description	1-1
1-3 ShockLine MS46122A Series VNA Models	1-1
Options	1-2
1-4 ShockLine MS46122A VNA Instrument Control	1-2
The MS46122A Series VNA is controlled via:	1-2
Graphical User Interface	1-2
1-5 Accessories	1-2
1-6 Calibration and Verification Kits	1-2
Precision Component and Calibration Kits	1-2
Mechanical Calibration Kits	1-3
Verification Kits	1-3
1-7 User Documentation	1-3
Updates to Manuals	1-3
Documentation Conventions	1-3
Instrument Identification	1-3
Instrument Connectors	1-3
User Interface, Menus, and Soft Buttons	1-4
User Interface Navigation	1-4
User Input	1-4

Chapter 2 — Installation

2-1 Introduction	2-1
2-2 Unpacking the Product	2-1
Initial Inspection	2-1
Preparation for Use	2-1
2-3 Operating Environment and Power Requirements	2-1
2-4 Power-On/Power-Off Procedures	2-2
Procedure – Power-On to Standby Mode	2-2
Procedure – Standby Mode to Operate Mode	2-3
Procedure – Power-Off	2-3
2-5 Installing ShockLine Software	2-4
Procedure	2-4
2-6 Connecting the External Computer	2-5
2-7 Running ShockLine Software	2-5
Procedure	2-5

Chapter 3 — Front and Rear Panels

3-1 Chapter Overview	3-1
3-2 Front Panel Components	3-1

Table of Contents (Continued)

3-3 Rear Panel Components	3-2
Rear Panel Label	3-2
Chapter 4 — User Interface Display	
4-1 Chapter Overview	4-1
4-2 User Interface Main Screen	4-1
User Interface Control and Display Areas	4-2
Function Access	4-4
4-3 Using the Menu Bar Interface	4-6
Menu Bar Overview	4-6
Menu Bar General Operation	4-7
Menu Bar Drop-down Menus and Commands	4-7
4-4 Icon Toolbar	4-16
Overview	4-16
Using the Icon Toolbar Interface	4-16
Available Icon Functions	4-17
4-5 MAIN Menu and Application Menus	4-23
4-6 Using the Main Menu Interface	4-25
Types of Menus, Menu Buttons, and Menu Toolbars	4-25
Menu Title	4-25
Menu Buttons	4-26
Menu Navigation Buttons	4-26
Menu Buttons	4-26
Read-Only Buttons	4-26
Function Buttons	4-27
Toggle Buttons	4-27
Field Selection Buttons	4-27
Field Toolbars	4-28
Auto-Return Button Groups	4-29
Completion Checkmark Button	4-30
4-7 Using Dialog Boxes	4-31
Standard Dialog Box Buttons	4-31
4-8 Instrument Status Display Area	4-32
Instrument Status Data	4-32
4-9 Instrument Status Display Area	4-33
4-10 Working with Channels	4-34

4-11 Working with Traces	4-34
Types of Trace Displays	4-34
Trace Data Types	4-34
Trace Display Graphs	4-35
Trace Labels	4-38
Trace Label Abbreviations	4-38
Rectilinear Single Graph	4-40
Rectilinear Paired Graphs	4-40
Smith Charts	4-41
Smith Chart with Impedance (Circuit Resistance and Reactance)	4-41
Polar Graphs	4-42
Group Delay Graphs	4-43
4-12 Working with Reference Lines and Reference Position	4-44
4-13 Working with Limit Lines	4-45

Appendix A — Vector Network Analyzer Primer

A-1 Appendix Overview	A-1
A-2 General Description	A-1
A-3 Instrument Description	A-2
Source Module	A-2
Test Set Module	A-2
Analyzer Module	A-2
A-4 Network Analyzers	A-3
Scalar Analyzer Comparison	A-3
Vector Network Analyzer Basics	A-4
A-5 Polar Display	A-12
Resistive and Reactive Terms	A-12
A-6 Smith Chart	A-13
Measurement Error Correction	A-13

Appendix B — Maintenance and Security

B-1 Rack Ear Installation	B-1
B-2 Security and Memory Overview	B-2
B-3 Preparation for Storage or Shipment	B-3
Preparation for Storage	B-3
Preparation for Shipment	B-3

Appendix C — Abbreviation Glossary

C-1 Appendix Overview	C-1
C-2 Glossary	C-1

Subject Index

Table of Contents (Continued)

Chapter 1 — Overview

1-1 Introduction

This chapter provides an overview of the ShockLine MS46122A Series Vector Network Analyzer (VNA) and a description of its major functions and available documentation. A summary of available precision component kits including mechanical calibration kits and verification kits is included.

1-2 ShockLine MS46122A Series VNA Description

The ShockLine MS46122A Series VNA is an instrument system that contains a built-in source, test set, and analyzer. The MS46122A is a 2-port Compact USB VNA that is controlled from an external pc running ShockLine software. Designed for simple engineering, manufacturing, and educational applications, the MS46122A series VNA supports manual test programming through the same Graphical User Interface (GUI) available on all the ShockLine family VNAs. Test results can be displayed real time on an external pc. Screen captures can easily be printed or saved in common graphic file formats.

The ShockLine MS46122A Series VNA provides a maximum frequency range from 1 MHz to 40 GHz. The MS46122A Series VNA has up to 16,001 total test points available with up to 16 channels with 16 trace display graphs per channel. Each trace can have up to 12 standard markers and one reference marker.



Figure 1-1. ShockLine VNA Front Panel

1-3 ShockLine MS46122A Series VNA Models

The ShockLine VNA is available in three frequency models as shown in [Table 1-1](#).

Table 1-1. ShockLine MS46122A Series VNA Models

VNA Model Number	Name	Specifications	Test Port Connectors
MS46122A-010	Compact Vector Network Analyzer	1 MHz – 8 GHz	N Connector Test Ports (2)
MS46122A-020	Compact Vector Network Analyzer	1 MHz – 20 GHz	K Connector Test Ports (2)
MS46122A-040	Compact Vector Network Analyzer	1 MHz – 40 GHz	K Connector Test Ports (2)

Options

Option	Descriptions
MS46122A-002	Time Domain with Time Gating

1-4 ShockLine MS46122A VNA Instrument Control

Other than test connectors, I/O connectors, and the standby power switch, there are no user controls on the front panel. The ShockLine MS46122A Series VNA is controlled and operated by an external PC controller loaded with ShockLine Software.

Note

The PC Controller is an External Computer which is not provided. Windows 7 or Windows 8 is required to run the ShockLine software that controls the MS46122A series VNA. The ShockLine Software is provided in the enclosed compact USB memory device or on the Anritsu website at: <http://www.anritsu.com>

The MS46122A Series VNA is controlled via:

- An external computer, monitor or touchscreen, keyboard and mouse
- ShockLine Software
- USB A to a Mini-B Connector

Graphical User Interface

The graphical user interface (GUI) provides a combination of a menu command bar, icon task bar, and right-side navigation menu for most system functions. All of the on-screen navigation elements can be accessed on the user supplied computer.

1-5 Accessories

Accessory	Part Number
External PC Controller with Windows 7 or Windows 8	Not Included
Computer AC to DC 12V 5A Power Supply	40-187-R
USB cable with a USB A to Mini-B Connector	3-2000-1498
Rack Ear Hardware	3-80790
Compact USB Memory Device with ShockLine Software	2000-559-R

1-6 Calibration and Verification Kits

Precision Component and Calibration Kits

Precision-component calibration and verification kits are available. Calibration kits contain components used to identify and separate error sources inherent in microwave test setups. Verification kits consist of components with characteristics traceable to the National Institute of Standards and Technology (NIST) and are used as the most dependable means of checking system accuracy. Each of these kits contains a USB memory device that provides coefficient, characterization, or measurement data for each component. Refer to the instrument data sheet for detailed specifications on automatic calibrators, mechanical calibration kits, and verification kits.

Mechanical Calibration Kits

The mechanical calibration kits provide 50 ohm calibrations for N or K devices.

Verification Kits

Verification kits can be used with the provided software and data to verify the calibration and resulting performance of the ShockLine MS46122A Series VNA. The applicable calibrations are Short-Open-Load-Thru (SOLT) using the Mechanical Cal kits.

1-7 User Documentation

The following ShockLine MS46122A Series Vector Network Analyzers documentation is available on the Anritsu web site and is provided with the instrument on the User Documentation USB device.

- MS46122A Series VNA ShockLine Operation Manual – 10410-00335
- All User Documentation above on a USB device – 2300-559

For additional technical specifications and configuration data, see the following publication:

- ShockLine MS46122A Series VNA ShockLine Technical Data Sheet - 11410-00822

Updates to Manuals

For updates to any of the MS46122A Series VNA documentation, visit the Anritsu web site at: <http://www.anritsu.com> or contact ShockLineVNA.support@anritsu.com.

Documentation Conventions

The following conventions are used throughout the entire MS46122A Series VNA documentation set:

Instrument Identification

Throughout this manual, the following term definitions are used:

- ShockLine VNA refers to any ShockLine VNA module or system.
- VNA refers to any ShockLine VNA module.
- MS46122A Series VNA refers to any of the VNAs in the MS46122A family.
- When required to identify a specific VNA model, the specific model number is used, such as MS46122A-010 (refers to the 8.0 GHz model).

Note

Many of the images in this document are used as typical representations of the product or of the product features. Your instrument and instrument displays may vary slightly from these images.

Instrument Connectors

Panel connectors are denoted with a bold Sans Serif font such as **10 MHZ IN**.

User Interface, Menus, and Soft Buttons

The ShockLine MS46122A Series VNA user interface consists of menus, button lists, sub-menus, toolbars, and dialog boxes. All of these elements are denoted with a special font. Generally, the top level menu items are denoted with a bold Sans Serif font and the subordinate items are denoted with a regular Sans Serif font, such as **Frequency** menu button.

User Interface Navigation

Elements in navigation shortcuts or paths are separated with the pipe symbol (“|”). Menu and dialog box names are distinctive Sans Serif font in CAPITALS. Button names are in Title Case. For example, the path to the Manual Cal menu is:

- MAIN | Calibration | CALIBRATION | Calibrate | CALIBRATE | Manual Cal | MANUAL CAL

User Input

User input such as entering values or other information is denoted in a mono-spaced font such as:

This font denotes a string of user input.

Chapter 2 — Installation

2-1 Introduction

This chapter provides information for the initial inspection and preparation for use of the ShockLine MS46122A Series VNA and includes information on instrument installation, loading ShockLine Software, required operating environment, power requirements, and initial inspection. After power up, the various power modes are described with general warm-up and calibration time intervals. The preventive maintenance section includes information on cleaning along with preparation for storage or shipment.

2-2 Unpacking the Product

Initial Inspection

Inspect the shipping container for damage. If the container or cushioning material is damaged, retain until the contents of the shipment have been checked against the packing list and the instrument has been checked for mechanical and electrical operation. If the ShockLine MS46122A Series VNA is physically damaged, notify your local sales representative or Anritsu Customer Service. If either the shipping container is damaged or the cushioning material shows signs of stress, notify the carrier as well as Anritsu. Keep the shipping materials for the carrier's inspection.

Preparation for Use

The ShockLine MS46122A Series VNA requires installation. To interface with the instrument through direct manual control, a Windows 7 or Windows 8 computer with keyboard, mouse, monitor or touchscreen, ShockLine Software, and interfacing USB cable are required.

2-3 Operating Environment and Power Requirements

Before installing the ShockLine MS46122A Series VNA in its operating environment, ensure airflow passages around the instrument are clear. Proper ventilation is of particular importance whenever the unit is being rack mounted. The ShockLine MS46122A Series VNA can be operated within the following environmental limits:

Table 2-1. Operational Environmental and Power Requirements

Parameter	Specification
Environmental Requirements (per MIL-PRF-28800F; class 3)	
Operating Temperature Range:	0 to +50 degrees Celsius
Relative Humidity:	5 % to 95 % at +45 degrees Celsius, non-condensing
Power Requirements	
Voltages:	90 to 264 VAC maximum (single phase)
Frequency:	47 to 63 Hz (power factor controlled)
Power:	350 VA maximum
Installation Category:	The ShockLine MS46122A Series VNA is intended for Installation Category (Overvoltage Category) II

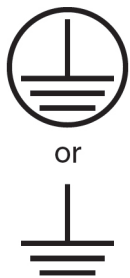
Warning

When supplying power to this equipment, connect the accessory power supply to a 3-pin grounded power outlet connected in turn to local AC Mains. If a grounded 3-pin outlet is not available, use a conversion adapter and ground the green wire, or connect the equipment frame to a suitable ground. If power is supplied without grounding the equipment, there is a risk of receiving a severe or fatal electric shock.

2-4 Power-On/Power-Off Procedures

The power-on procedure involves connecting the instrument power supply to AC Mains, using the front panel standby power switch to turn the instrument to standby mode, and then using the instrument software to toggle the instrument into operate mode. The power-off procedure involves switching the front panel standby power switch to off and unplugging the power supply from the unit to turn the instrument off.

Note

Unplugging the instrument, turning the standby power switch to off, or unplugging the usb cable when the unit is in operate mode will cause the ShockLine software interface to close. A popup dialog window will appear on the controller pc asking the user whether or not they would like to save their settings allowing the user to save their work. After the save is done the ShockLine software will close.



1. Standby Power Switch

2. Power Supply Input Connection

Figure 2-1. Front Panel Power Connection to AC Mains Power**Procedure – Power-On to Standby Mode**

To turn the instrument on:

1. Connect a power cord to the power supply. Connect the DC connector from the power supply to the power input connection on the front of the MS46122A. See [Figure 2-1](#)
2. Connect the AC power cord to local AC mains power.
3. Turn on the standby power switch.

Procedure – Standby Mode to Operate Mode

To set the instrument to operate mode:

- Connect the MS46122A to the user provided Windows 7 or Windows 8 computer via the USB cable included with the unit.
- Start the ShockLine software by double clicking the ShockLine icon on the desktop.
- When fully in operate mode, the computer controlling the ShockLine MS46122A Series VNA displays the main trace display with the application menus on the right side. See [Figure 4-1, “User Interface - Four Traces - Frequency Menu \(simulated data\)”](#) for a typical full screen display.

Note

When placing the ShockLine MS46122A Series VNA in operation, allow at least 30 minutes of warm-up time in the operate mode before using the VNA to assure stable operation and the highest possible accuracy.



Figure 2-2. ShockLine Series VNA Startup Splash Screen

Procedure – Power-Off

Turn off the instrument by toggling the front panel standby power switch and unplugging the external power supply. Shutting down the ShockLine software on the external pc does not power down the MS46122A hardware.

Note

After turning off the instrument, you must wait at least 15 seconds before turning the instrument back on again. This delay is required to assure a reliable cold start.

Switching off the standby power switch or unplugging the external power supply from the VNA will cause the ShockLine software on the external pc controlling the unit to shutdown.

2-5 Installing ShockLine Software

Note An external computer with Windows 7 or Windows 8 Operating System is required to load the ShockLine software.



MS46122A Front Panel



MS46122A Rear Panel

Figure 2-3. MS46122A Front Panel and Rear Panel

Procedure

- Power up the external PC.
- Load the ShockLine Software provided from the USB memory device (Anritsu part number 2300-559-R) into the PC.
- Run the ShockLine software installer as Administrator and follow the instructions displayed on the monitor to complete the installation of the software onto the PC.

2-6 Connecting the External Computer

After unpacking, the ShockLine MS46122A Series VNA is ready for use. In order to enable the ShockLine VNA application to control the MS46122A, you must connect a USB A to Mini-B cable between the VNA and to an external computer pre-loaded with the ShockLine Software.

Note

Advanced keyboard and mouse features may not be supported in the analyzer application, but should function as expected in the Windows environment.



1. Mini USB Port

Figure 2-4. ShockLine MS46122A Series VNA USB Connection

2-7 Running ShockLine Software

Procedure

The ShockLine software communicates with the VNA hardware through an Anritsu USB driver.

- Power up the MS46122A VNA by plugging in the power supply and switching on the standby power switch.
- Connect to the computer with a USB cable.
- Confirm that the Anritsu USB driver has been installed by checking the Windows device manager under the Universal Serial Bus Controllers. See [Figure 2-5](#).
- Double click the ShockLine desktop icon to launch the ShockLine software to use the MS46122A.

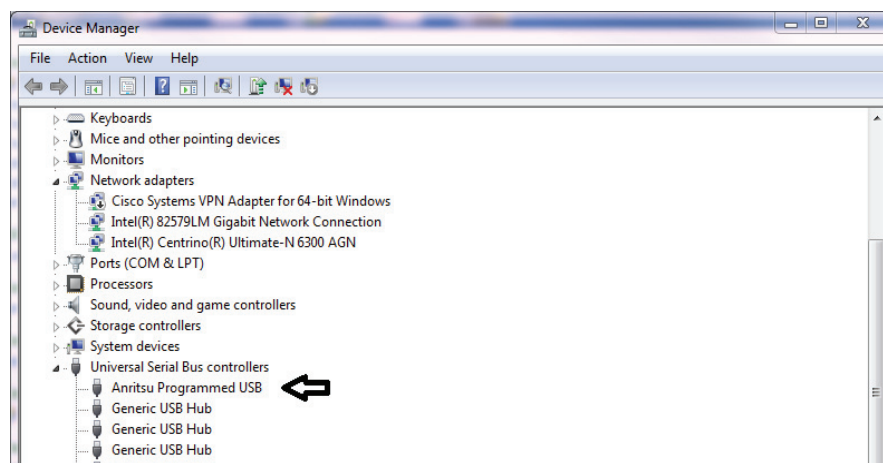

Figure 2-5. Universal Serial Bus Controllers

Chapter 3 — Front and Rear Panels

3-1 Chapter Overview

The chapter provides an overview of the MS46122A Series VNA hardware user interface including front panel buttons and front panel connectors. Included are photographs of the front and rear panels. Each port and connector is described with its connector type, its function, input/output limits, and a cross-reference to a detailed connector pin-out diagram.

3-2 Front Panel Components

The MS46122A Series VNA front panel and port connectors are identified below in [Figure 3-1](#).

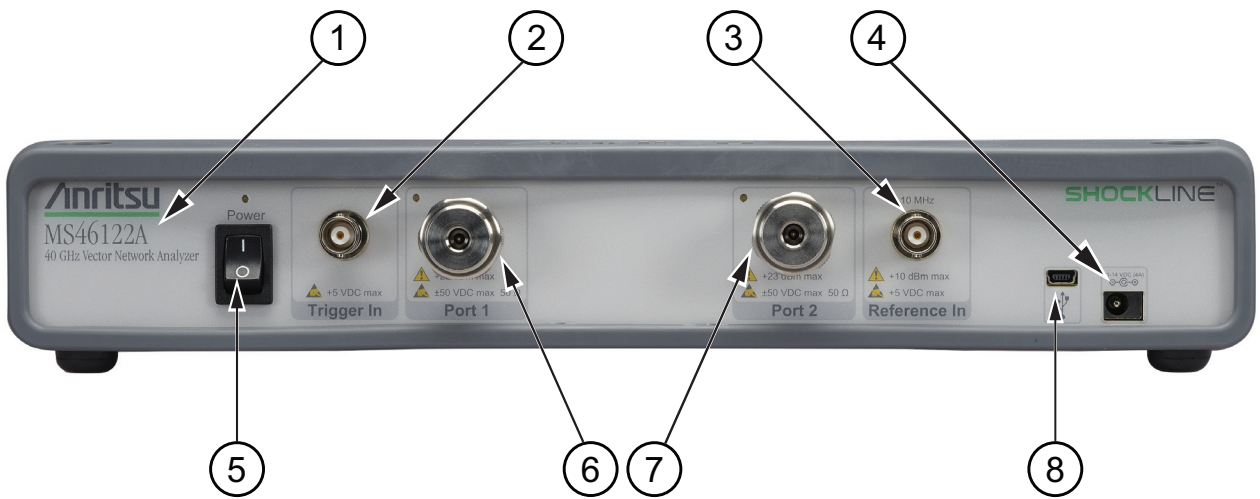

- | | |
|--|-------------------------------|
| 1. ID Plate – Instrument model number identification | 5. Standby Power Switch |
| 2. Trigger In | 6. Test Port 1 – K(m) or N(f) |
| 3. 10 MHz External Reference Input | 7. Test Port 2 – K(m) or N(f) |
| 4. DC Power Supply Connector | 8. USB Port |

Figure 3-1. MS46122A VNA Front Panel

3-3 Rear Panel Components

The MS46122A Series VNA rear panel is shown below [Figure 3-2, “MS46122A Rear Panel”](#).

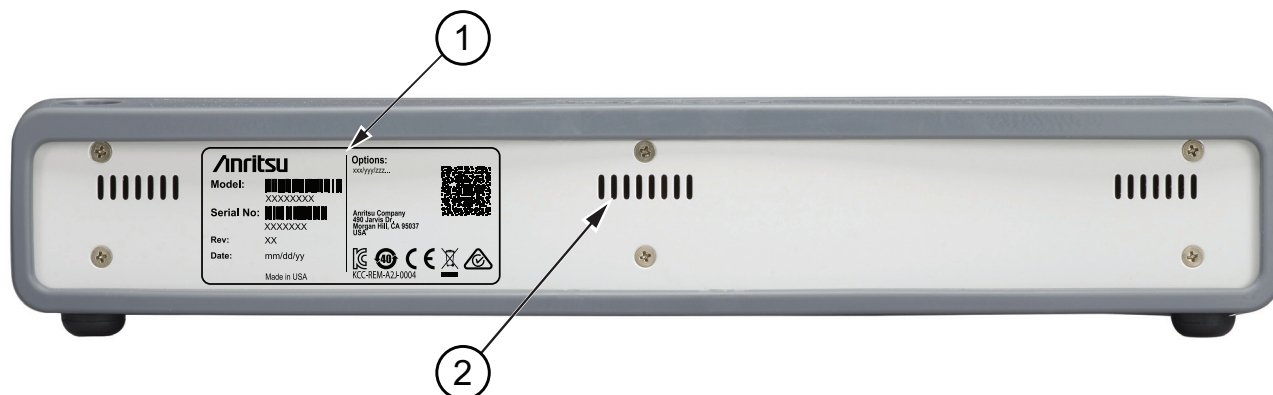

1. Serial Number and Model Number Label

2. Air Flow Vent (one of three)

Figure 3-2. MS46122A Rear Panel

Rear Panel Label

The label that is attached to the rear panel displays the:

- Anritsu Company logo
- Serial number
- Model number
- Revision (Rev) number
- Date of manufacture
- Options installed
- Compliance markings
- Identification barcode

Chapter 4 — User Interface Display

4-1 Chapter Overview

The chapter describes the general display options of the ShockLine MS46122A Series VNA and provides a general description of the MENU BAR, the ICON TOOLBAR, and the right-side function menus. General descriptions and procedures are provided for trace graph setup, marker setup, and limit line setup.

4-2 User Interface Main Screen



Figure 4-1. User Interface - Four Traces - Frequency Menu (simulated data)

User Interface Control and Display Areas

The instrument main display can be manipulated by clicking with an attached USB mouse. The figure below shows the general display areas for a single channel displaying four graphical traces.

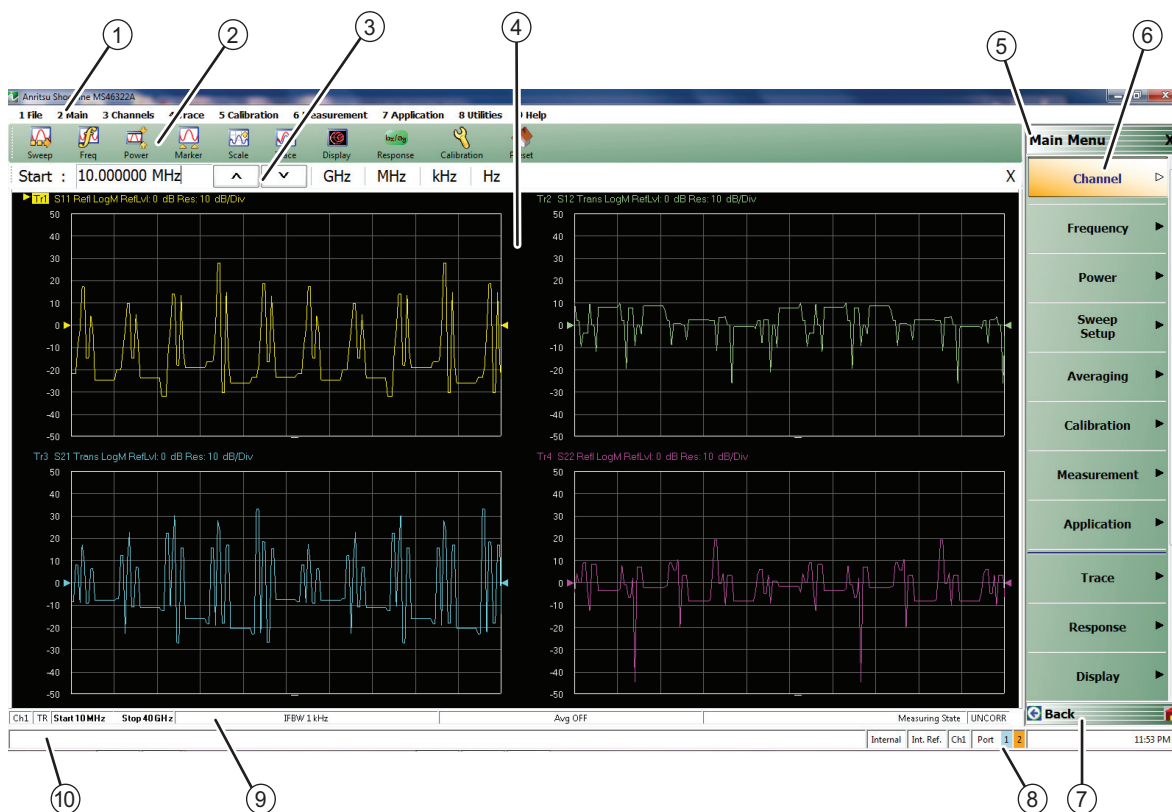

1. Menu Bar – Displays nine (9) drop down menus: File, Main, Channels, Trace, Calibration, Measurement, Application, Utilities, and Help.
2. Icon Toolbar – User-configured with up to 10 user-selected quick access icons.
3. Field Toolbar – Appears only when field button is clicked for input. Display field for value, with one or more units (such as dB, dBm, or Hz), an Enter button, and an X close button.
4. Display Area – Displays from one to 16 trace display graphs. Each trace display can optionally have from one to 12 markers, a reference marker, and an upper and lower limit line.
5. Menu Title – Displays the name of the displayed right-side menu. Menu titles are unique to each menu.
6. Menu Buttons – The menu buttons allow the user to set parameters, make configuration selections, read result values, start processes, toggle between two or more values, display sub-menus, and display dialog boxes.
7. Menu Navigation Buttons – The navigation buttons always appear at the bottom of the right-side menu and allow browser-like forward and backward navigation through the user's history. Back returns to previous selected higher-level menu, Next returns to a previously selected lower-level menu, and Home returns to the Main Menu.
8. System Status Bar – Displays status messages, and configuration status that affects the entire instrument.
9. Trace Status Bar – Provides status for active trace near the bottom of the screen.
10. Tableau Data Display/Input Area – The tableau area only appears when the appropriate menu button is selected. When selected, the display shrinks upwards and the tabular data area expands.

Figure 4-2. User Interface Display Areas

For all ShockLine MS46122A Series VNA models, the user can have up to 16 graphical traces. The figure below shows an instrument setup with four displayed windows, each with three traces. The displayed trace display layout shown below is user-defined as a 2 × 2 configuration trace display.

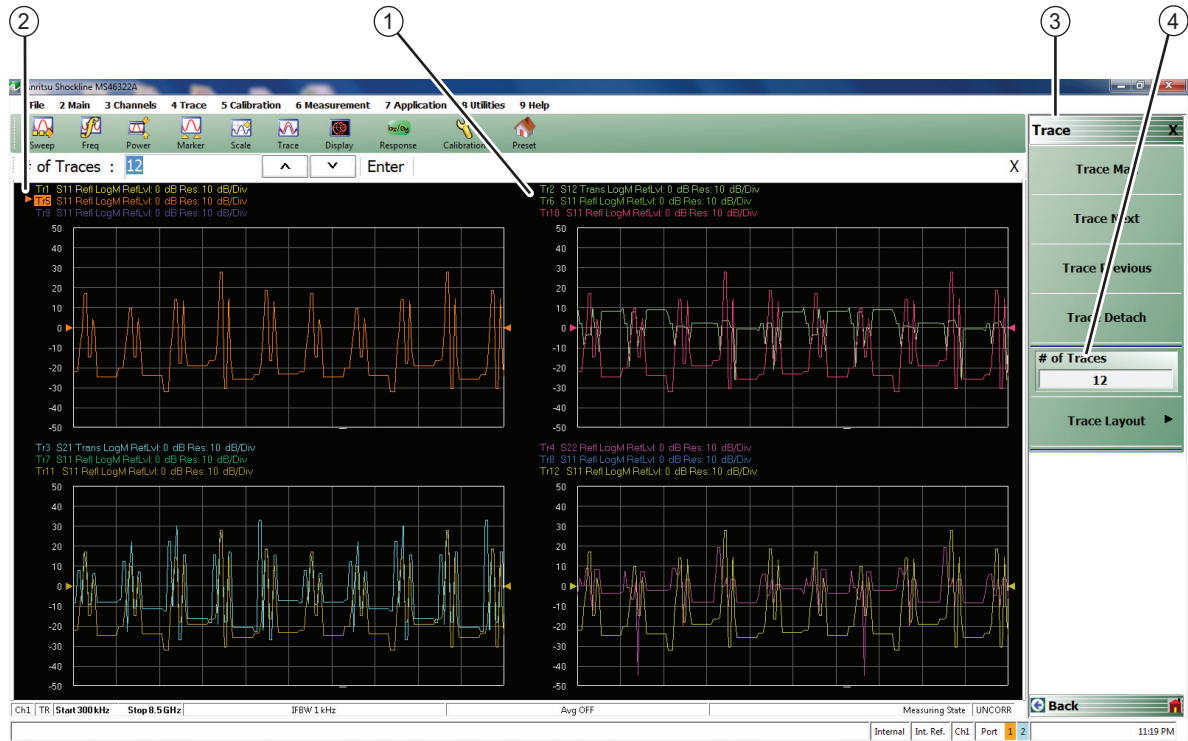

Figure 4-3. User Interface - 12 Traces (simulated data)

- | | |
|-----------------------------------|--|
| 1. Three Traces per screen | 3. Trace Menu |
| 2. Arrow Pointing to Active Trace | 4. Number of Traces Selected for Viewing |



Figure 4-4. Single Trace Displayed (simulated data)

Function Access

The ShockLine MS46122A Series VNA software user interface provides access to menus and functions using an external computer.

A keyboard and mouse or touchscreen can be used to control the instrument through five major user interface areas on the main display:

- The top **MENU BAR** with its drop-down menus and menu commands.
- The **ICON TOOLBAR** with up to 10 single-click functions, available as a default configuration or as a user-definable configuration of icon functions.
- The right side **MAIN MENU** provides access to function menus, sub-menus, dialog boxes, and configuration options.
- For some parameters, selecting a button displays a **FIELD TOOLBAR** that appears just below the icon toolbar allowing input of parameter values and units.
- For some parameters, selecting a button displays a **CONFIGURATION** or **SETUP TABLEAU** below the main display area for input of complex parameter sets such as segmented frequency or power sweeps.

To Select a Channel

1. Select a channel in a multi-channel display by doing one of the following:
 - Click anywhere inside the desired channel box.
 - From the keyboard, enter **ALT + 3**, then **3** to view the previous channel or **ALT + 3**, then **4** to view the next channel.
 - On the top menu bar, select **MENU BAR | Channels | Channel Prev** or **MENU BAR | Channel | Channel Next**.
 - On the right side menu, select **MAIN | Channels | CHANNELS | Chan Next** or **Chan Previous**.
2. The selected channel border changes from gray to white. (Figure 4-3, “User Interface - 12 Traces (simulated data)” on page 4-3 shows Channel 2 (Ch2) selected.)

Note	The Ch->Max , Ch->Next , and Ch-Prev icons are available for the icon toolbar. These icons provide one click access to channel maximum, channel next, and channel previous functions. They can be added to the icon toolbar for a custom configuration and saved as part of a preset configuration.
-------------	--

To Maximize a Channel Display

1. Use one of the methods above to select the desired channel.
2. Do one of the following to maximize the selected channel:
 - From the keyboard, enter **CTRL + 1** or **ALT + 3**, then **2**.
 - On the main display, double-click the channel border box.
 - On the top menu bar, select **MENU BAR | Channel | Channel Max**.
 - On the right side menu, select **MAIN | Channel | CHANNEL | Chan. Max**.
3. The selected channel now fills the display area.
 - Maximize a channel display to review the channel status information at the bottom of its screen.

To Make the Display Area Larger

1. The top icon toolbar and the right side menus can be removed to make the display area larger.
2. Remove the icon toolbar by doing one of the following:
 - From the keyboard, select **ALT + 8**, then **2**.
 - On the top menu bar, select MENU BAR | Utilities | Toolbar Off.
3. The icon toolbar disappears. Repeat **Step #2** to make the icon toolbar reappear.
4. Remove the right side menus by doing one of the following:
 - From the keyboard, enter **ALT + 8**, then **7**.
 - On the top menu bar, select MENU BAR | Utilities | Clear.
5. The right side menu disappears. Repeat **Step #4** to make the menu reappear.

To Select Traces

1. Use one of the methods above to maximize the channel display.
2. Select a trace in a multi-trace display by doing one of the following:
 - With a mouse, single click the trace title.
 - If you double-click either the trace title or anywhere within the trace, the trace is both selected and maximized.
 - From the keyboard, enter **ALT + 4**, then **7** to view the previous trace or **ALT + 4**, then **8** to view the next trace.
 - On the top menu bar, select MENU BAR | Trace | Trace Prev or MENU BAR | Trace | Trace Next.
 - On the right side menu, select MAIN | Trace | TRACE | Trace Previous or Trace Next.
 - The selected trace number is highlighted and a left arrow appears.



Figure 4-5. Trace Selection Indicator

Note	The Tr->Max , Tr->Next , and Tr->Previous icons are available for the icon toolbar. These icons provide one click access to trace maximum, trace next, and trace previous functions. They can be added to the icon toolbar for a custom configuration and saved as part of a preset configuration.
-------------	--

To Maximize a Trace Display

1. Use one of the methods above to select the desired trace.
2. For a maximum display, make sure the trace's channel is maximized.
3. Do one of the following to maximize the selected trace:
 - From the keyboard, select **ALT + 4**, then **6**.
 - On the main display, double-click anywhere in the trace display.
 - On the top menu bar, select MENU BAR | Trace | Trace Max.
 - On the right side menu, select MAIN | Trace | TRACE | Trace Max.
4. The selected trace now fills the display area.
 - Maximize a trace display to review the trace status information at the bottom of trace screen.
5. Repeat the actions above to return the trace to its normal size.

4-3 Using the Menu Bar Interface

Menu Bar Overview

The menu bar at the top of the screen provides drop-down menus for access to major ShockLine VNA functions and dialogs. The figure below shows all of the available MENU BAR functions and command menus.

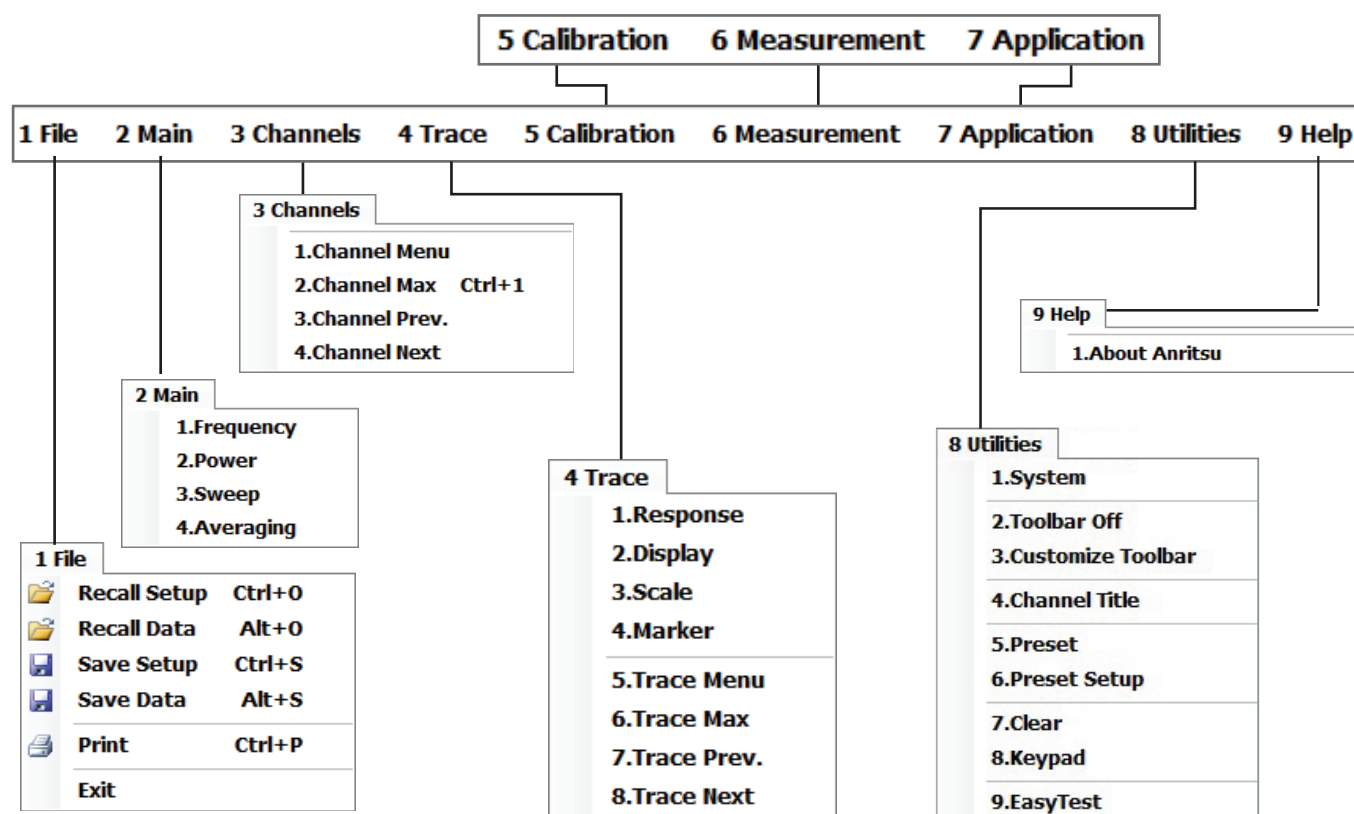

Figure 4-6. MENU BAR Major Functions, Drop-Down Menus, and Commands

Menu Bar General Operation

The MENU BAR drop-down menus and commands can be accessed by clicking on the menu bar and required command.

The keyboard can be used to enter the menu and/or command short cut, most of which use the **ALT (ALTERNATE)** key. To access a menu from the keyboard, press and hold the **ALT (ALTERNATE)** key and the number in front of the menu name.

- For example, **ALT + 1** opens the FILE menu.
- For example, **ALT + 8** opens the UTILITY menu.

To access most commands listed on the drop-down menus, follow the **ALT +** sequence with the menu command number.

- For example, to access the Preset command on the UTILITIES menu, enter **ALT + 8**, then **5**.
- For example, to access the right side SYSTEM menu, enter **ALT + 8**, then **1**.

Some MENU BAR menu commands can also be accessed by using the keyboard **Control (CTRL)** key. Press and hold the **CTRL** key and then the letter key.

- For example, to recall a previously saved setup, enter **CTRL + O** (letter O).
- For example, to print the current display screen, enter **CTRL + P**.

Menu Bar Drop-down Menus and Commands

The menu bar appears at the top of the instrument display and provides direct access to system menus and some button functions.

The table below summarizes all menu bar drop down commands and provides cross references to sections that describe the resultant menu or command in greater detail.

Table 4-1. Menu Bar Drop-Down Menu Descriptions (1 of 9)

Menu and Command Name	Menu and Command Descriptions
<p>FILE Drop-Down Menu</p>	<div data-bbox="815 1129 1238 1461" data-label="Image"> </div> <ul style="list-style-type: none"> • Keyboard: ALT + 1 • MENU BAR File • MAIN File FILE
<p>Recall Setup Command</p>	<p>Select displays the RECALL SETUP dialog box and allows the recall of previously saved setup and/or calibration files:</p> <ul style="list-style-type: none"> – Active Channel Setup and Calibration (.chx) File – Active Channel Setup (.stx) File – All Channel Setup (.sta) File <ul style="list-style-type: none"> • Keyboard: CTRL + O (letter O) • MENU BAR File Recall Setup • MAIN File FILE Recall Setup RECALL SETUP Dialog Box

Table 4-1. Menu Bar Drop-Down Menu Descriptions (2 of 9)

Menu and Command Name	Menu and Command Descriptions
Recall Data Command	<p>Select displays the RECALL DATA dialog box and allows the recall of a previously saved active channel and/or active trace data file of these types:</p> <ul style="list-style-type: none"> – Active Channel S1P (.s1p), S2P (.s2p), S3P (.s3p), S4P (.s4p) Files – Formatted Data into Active Trace (.tdf) File – Unformatted Data into Active Trace (.tdu) File – Formatted Data into Active Trace Memory (.tdf) File – Unformatted Data into Active Trace Memory (.tdu) File <ul style="list-style-type: none"> • Keyboard: ALT + O (letter O) • MENU BAR File Recall Data • MAIN File FILE Recall Data RECALL DATA Dialog Box
Save Setup Command	<p>Select displays the Save Setup dialog box and allows the user to save the currently applied system presets configuration file.</p> <ul style="list-style-type: none"> • Keyboard: CTRL + S • MENU BAR File Save Setup • MAIN File FILE Save Setup SAVE SETUP Dialog Box
Save Data Command	<p>Select displays the SAVE DATA (Active Channel.txt) dialog box. Use this dialog to save the current channel data file.</p> <ul style="list-style-type: none"> • Keyboard: ALT + S • MENU BAR File Save Data • MAIN File FILE Save Data SAVE DATA Dialog Box
Print Command	<p>Select displays the Windows PRINT dialog box to print the current main display.</p> <ul style="list-style-type: none"> • Keyboard: CTRL + P • MENU BAR File Print • MAIN File Print PRINT Dialog Box
Exit Command	<p>Select displays a confirmation dialog box. Click OK to exit the ShockLine application and return to the Windows desktop. Click Cancel to remain in the ShockLine application.</p> <ul style="list-style-type: none"> • MENU BAR File Exit

Table 4-1. Menu Bar Drop-Down Menu Descriptions (3 of 9)

Menu and Command Name	Menu and Command Descriptions
<p>MAIN Drop-Down Menu</p>	<div data-bbox="869 262 1184 485" style="border: 1px solid black; padding: 5px; margin: 10px auto; width: fit-content;"> <p>2 Main</p> <ul style="list-style-type: none"> 1.Frequency 2.Power 3.Sweep 4.Averaging </div> <ul style="list-style-type: none"> • Keyboard: ALT + 2 • MENU BAR Main
<p>Frequency</p>	<p>Select displays the right-side FREQUENCY menu.</p> <ul style="list-style-type: none"> • Front Panel Key: Frequency • Keyboard: ALT + 2, then 1 • MENU BAR Channel Frequency • MAIN Frequency FREQUENCY
<p>Power</p>	<p>Select displays the right-side POWER menu.</p> <ul style="list-style-type: none"> • Front Panel Key: Power • Keyboard: ALT + 2, then 2 • MENU BAR Channel Power • MAIN Power POWER
<p>Sweep</p>	<p>Select displays the right-side SWEEP SETUP menu.</p> <ul style="list-style-type: none"> • Front Panel Key: Sweep • Keyboard: ALT + 2, then 3 • MENU BAR Channel Sweep • MAIN Sweep Setup SWEEP SETUP
<p>Averaging</p>	<p>Select displays the right-side AVERAGING menu.</p> <ul style="list-style-type: none"> • Front Panel Key: Avg (Average) • Keyboard: ALT + 2, then 4 • MENU BAR Channel Averaging • MAIN Averaging AVERAGING

Table 4-1. Menu Bar Drop-Down Menu Descriptions (4 of 9)

Menu and Command Name	Menu and Command Descriptions
CHANNELS Drop-Down Menu	 <ul style="list-style-type: none"> • Keyboard: ALT + 3 • MENU BAR Channels • MAIN Channels CHANNELS
Channel Menu Command	<p>Select displays the right-side CHANNEL menu.</p> <ul style="list-style-type: none"> • Keyboard: ALT + 3, then 1 • MENU BAR Channels Channel Menu • MAIN Channels CHANNELS
Channel Max Command	<p>Select maximizes the display of the active channel. Select again returns to the previous multi-channel display.</p> <ul style="list-style-type: none"> • Keyboard: ALT + 3, then 2 • Keyboard: CTRL + 1 • MENU BAR Channels Channel Max • MAIN Channels CHANNELS Chan. Max
Channel Previous Command	<p>Selects the next lower channel number. If channel 1 was previously selected, selects the highest numbered channel.</p> <ul style="list-style-type: none"> • Keyboard: ALT + 3, then 3 • MENU BAR Channels Channel Prev. • MAIN Channels CHANNELS Chan. Previous
Channel Next Command	<p>Selects the next higher channel number. If the highest numbered channel was previously selected, selects channel 1.</p> <ul style="list-style-type: none"> • Keyboard: ALT + 3, then 4 • MENU BAR Channels Channel Next • MAIN Channels CHANNELS Chan. Next

Table 4-1. Menu Bar Drop-Down Menu Descriptions (5 of 9)

Menu and Command Name	Menu and Command Descriptions
<p>TRACE Drop-Down Menu</p>	<div data-bbox="847 262 1177 667" style="border: 1px solid black; padding: 5px; margin-bottom: 10px;"> <p>4 Trace</p> <ul style="list-style-type: none"> 1.Response 2.Display 3.Scale 4.Marker <hr/> 5.Trace Menu 6.Trace Max 7.Trace Prev. 8.Trace Next </div> <ul style="list-style-type: none"> • Keyboard: ALT + 4 • MENU BAR Trace • MAIN Trace TRACE
<p>Response Command</p>	<p>Select displays the right-side RESPONSE menu.</p> <ul style="list-style-type: none"> • Keyboard: ALT + 4, then 1 • MENU BAR Trace Response • MAIN Response RESPONSE
<p>Display Command</p>	<p>Select displays the right-side DISPLAY menu.</p> <ul style="list-style-type: none"> • Keyboard: ALT + 4, then 2 • MENU BAR Trace Display • MAIN Display DISPLAY
<p>Scale Command</p>	<p>Select displays the right-side SCALE menu. The name of the SCALE menu (and the buttons on it) depend on the display type selected such as:</p> <ul style="list-style-type: none"> – Scale (Log Mag) – Scale (Lin Mag) – Scale (Phase) – Scale (Real) – Scale (Imag) – Scale (SWR) <ul style="list-style-type: none"> • Keyboard: ALT + 4, then 3 • MENU BAR Trace Scale • MAIN Scale SCALE
<p>Marker Command</p>	<p>Select displays the right-side MARKERS [1] menu.</p> <ul style="list-style-type: none"> • Keyboard: ALT + 4, then 4 • MENU BAR Trace Marker • MAIN Marker MARKER [1]
<p>Trace Menu Command</p>	<p>Select displays the right-side TRACE menu.</p> <ul style="list-style-type: none"> • Keyboard: ALT + 4, then 5 • MENU BAR Trace Trace Menu • MAIN Trace TRACE

Table 4-1. Menu Bar Drop-Down Menu Descriptions (6 of 9)

Menu and Command Name	Menu and Command Descriptions
Trace Max Command	<p>Select maximizes the active trace to full screen display. Selecting again, returns the trace to the standard multi-trace display.</p> <ul style="list-style-type: none"> • Keyboard: ALT + 4, then 6 • MENU BAR Trace Trace Max • MAIN Trace TRACE Trace Max
Trace Previous Command	<p>Selects the next lower trace number on the active channel. If Trace 1 is currently selected, the highest numbered trace is selected. If the current trace is not maximized, the previous trace will not be maximized. If the current trace is maximized, the previous trace will be maximized.</p> <ul style="list-style-type: none"> • Keyboard: ALT + 4, then 7 • MENU BAR Trace Trace Prev. • MAIN Trace TRACE Trace Previous
Trace Next Command	<p>Selects the next higher trace number on the active channel. If the highest numbered trace is currently displayed, the Trace 1 is displayed. If the current trace is not maximized, the next trace will not be maximized. If the current trace is maximized, the next trace will be maximized.</p> <ul style="list-style-type: none"> • Keyboard: ALT + 4, then 8 • MENU BAR Trace Trace Next • MAIN Trace TRACE Trace Previous

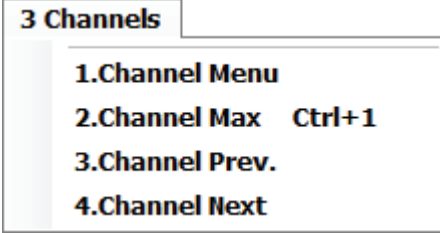
Table 4-1. Menu Bar Drop-Down Menu Descriptions (7 of 9)

Menu and Command Name	Menu and Command Descriptions
<p>CALIBRATION Drop-Down Menu</p>	<div style="text-align: center; border: 1px solid black; padding: 2px; width: fit-content; margin: 0 auto;">5 Calibration</div> <p>The CALIBRATION drop-down menu has one command that selects the right-side CALIBRATION menu</p> <ul style="list-style-type: none"> • Keyboard: ALT + 5 • MENU BAR Calibration • MAIN Calibration CALIBRATION
<p>MEASUREMENT Drop-Down Menu</p>	<div style="text-align: center; border: 1px solid black; padding: 2px; width: fit-content; margin: 0 auto;">6 Measurement</div> <p>Select displays the right-side MEASUREMENT menu.</p> <ul style="list-style-type: none"> • Keyboard: ALT + 6 • MENU BAR Measurement • MAIN Measurement MEASUREMENT
<p>APPLICATION Drop-Down Menu</p>	<div style="text-align: center; border: 1px solid black; padding: 2px; width: fit-content; margin: 0 auto;">7 Application</div> <p>The APPLICATION menu/command selects the right-side APPLICATION menu.</p> <ul style="list-style-type: none"> • Keyboard: ALT + 7 • MENU BAR Application • MAIN Application APPLICATION
<p>UTILITIES Drop-Down Menu</p>	<div style="border: 1px solid black; padding: 5px; margin: 0 auto; width: fit-content;"> <p>8 Utilities</p> <ul style="list-style-type: none"> 1.System 2.Toolbar Off 3.Customize Toolbar 4.Channel Title 5.Preset 6.Preset Setup 7.Clear 8.Keypad 9.EasyTest </div> <ul style="list-style-type: none"> • Keyboard: Alt + 8 • MENU BAR Utilities
<p>System Command</p>	<p>Select displays the right-side SYSTEM menu.</p> <ul style="list-style-type: none"> • Keyboard: Alt + 8, then 1 • MENU BAR Utilities System • MAIN System SYSTEM

Table 4-1. Menu Bar Drop-Down Menu Descriptions (8 of 9)

Menu and Command Name	Menu and Command Descriptions
Toolbar Off Command	<p>Toggles the ICON TOOLBAR, immediately below the MENU BAR, on and off.</p> <ul style="list-style-type: none"> • Keyboard: Alt + 8, then 2 • MENU BAR Utilities Toolbar Off
Customize Toolbar Command	<p>Select displays the CUSTOMIZE TOOLBAR dialog box and allows the user to select which icons are to be displayed in the toolbar. Up to 10 icons can be displayed at one time and there are a total of 24 available icons. The Icon Toolbar configuration is saved when a Preset Save is completed.</p> <ul style="list-style-type: none"> • Keyboard: Alt + 8, then 3 • MENU BAR Utilities Customize Toolbar
Channel Title Command	<p>Select displays the DISPLAY SETUP menu and allows a user-defined title to be applied to and displayed above the active channel. Each channel can have a different or the same title.</p> <ul style="list-style-type: none"> • Keyboard: Alt + 8, then 4 • MENU BAR Utilities Channel Title • MAIN Display DISPLAY Display Area Setup DISPLAY SETUP Edit Chan. Title EDIT CHANNEL TITLE Dialog Box
Preset Command	<ul style="list-style-type: none"> • Returns the instrument to its prior saved state which can be either the factory-default preset, or a user-defined setup. The PRESET SETUP menu selection defines which is used. • Keyboard: Alt + 8, then 5 • MENU BAR Utilities Preset • No right-side menu available to preset the instrument: <ul style="list-style-type: none"> – Use the Menu Bar Function above.
Preset Setup Command	<p>Select displays the PRESET SETUP menu and allows user-defined preset parameters to be applied during a preset command.</p> <ul style="list-style-type: none"> • Keyboard: Alt + 8, then 6 • MENU BAR Utilities Preset Setup
Clear Command	<p>Select toggles the displayed right-side menu off and on. When toggled back on, the previously selected menu is displayed. For example, if the CALIBRATE function menu was displayed when the display was cleared, the CALIBRATE function menu is again displayed when Clear is selected a second time.</p> <ul style="list-style-type: none"> • Keyboard: Alt + 8, then 7 • MENU BAR Utilities Clear Command
KeyPad Off Command	<p>Select toggles the display of the keypad dialog window off and on. The keypad allows for easier entry of input parameters.</p> <ul style="list-style-type: none"> • Keyboard: Alt + 8, then 8 • MENU BAR Utilities KeyPad Off Command

Table 4-1. Menu Bar Drop-Down Menu Descriptions (9 of 9)

Menu and Command Name	Menu and Command Descriptions
<p>HELP Drop-Down Menu</p>	<div data-bbox="794 262 1268 367" style="border: 1px solid black; padding: 5px; margin-bottom: 10px;"> <p>9 Help</p> <p>1.About Anritsu</p> </div> <ul style="list-style-type: none"> • Keyboard: ALT + 9 • MENU BAR Help
<p>About Anritsu Command</p>	<p>Select displays the ABOUT SHOCKLINE dialog box with typical information as shown below.</p> <div data-bbox="555 546 1500 1234" style="border: 1px solid black; padding: 10px; margin-bottom: 10px;"> </div> <p>The dialog box provides instrument configuration information. Click OK to close the dialog box. The following information is provided:</p> <ul style="list-style-type: none"> – Copyright Statement – Software Version – Firmware Version – Model Number – Serial Number – Options Installed

4-4 Icon Toolbar

Overview

The Icon Toolbar is located immediately below the Menu Bar and allows single-click access to many menus and functions. The icon toolbar is user-configurable and up to 10 icons can be displayed in any configuration.

Using the Icon Toolbar Interface

The default Icon Toolbar is shown below:

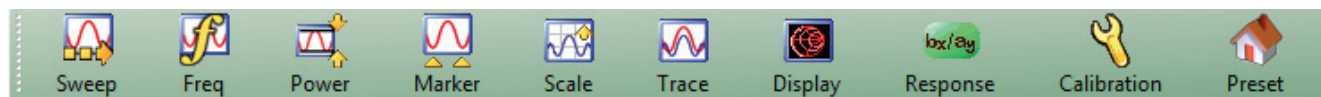

The definitions and functions of the default icons are (from left to right):

- **Sweep Icon** – Select displays the right-side Sweep menu.
- **Freq Icon** – Select displays the right-side FREQUENCY menu.
- **Power Icon** – Select displays the right-side POWER menu.
- **Marker Icon** – Select displays the right-side MARKERS [1] menu.
- **Scale Icon** – Select displays the right-side SCALE menu.
- **Trace Icon** – Select displays the right-side TRACE menu.
- **Display Icon** – Select displays the right-side DISPLAY menu.
- **Response Icon** – Select displays the right-side RESPONSE menu.
- **Calibration Icon** – Select displays the right-side CALIBRATION menu.
- **Preset Icon** – Select returns the system to its prior preset status at the time of the last preset save. All available icons are described in the in [Table 4-2](#).

Figure 4-7. Icon Toolbar with Factory Default Function Icons

Available Icon Functions

The available icon functions that can be added to a user-defined icon toolbar are listed in table below. Once configured, a preset save allows the toolbar configuration to be recalled at any time.

The procedures for changing the icon toolbar are described following the icon table and uses the “[CUSTOMIZE TOOLBAR Dialog Box](#)” on page 4-21 below. When a user-defined toolbar is configured, the first selected icon goes to the left-most position on the toolbar. The tenth selected icon goes to the right-most position on the toolbar.

Table 4-2. Icon Descriptions - Listed Alphabetically (1 of 5)







Icon Name	Icon	Description
<i>Icon Description Definitions</i>		<p>Default Icons – These are one of the 10 default icons and are provided after a return to the factory standard configuration.</p> <p>Keyboard – If available, the keyboard shortcut to access this menu or function.</p> <p>Menu Bar – If available, navigation path to access this menu or function.</p> <p>Navigation – To navigate to this menu or function from the MAIN menu.</p> <p>Description – If available, where this menu, dialog box, or function is described in greater detail in this document.</p>
Calibration Icon	 Calibration	<p>Default Icon. Select displays the right-side CALIBRATION menu.</p> <ul style="list-style-type: none"> • Keyboard: ALT + 5 • MENU BAR Calibration • MAIN Calibration CALIBRATION
Continue Icon	 Continue	<p>After a system pause or hold with the Hold icon, the Continue icon resumes operation with all prior settings in effect.</p> <ul style="list-style-type: none"> • MAIN Sweep Setup SWEEP SETUP Hold Functions HOLD FUNCTIONS Continue
Channel Icon	 Channel	<p>Default Icon. Select displays the right-side CHANNEL menu.</p> <ul style="list-style-type: none"> • Front Panel Key: Channels • MAIN Channels Channels Menu
Ch->Max Icon	 Ch->Max	<p>When multiple channels are used, select activates and displays the channel with the maximum trace value.</p> <ul style="list-style-type: none"> • MAIN Channels CHANNELS Channel Max
Ch->Prev Icon	 Ch->Prev	<p>When multiple channels are used, select activates and displays the next lower channel number. If channel 1 (one) is currently active, the highest numbered channel is activated and displayed.</p> <ul style="list-style-type: none"> • MAIN Channels CHANNELS Channel Prev.
Ch->Next Icon	 Ch->Next	<p>When multiple channels are used, select activates and displays the next higher channel number. If the highest channel number is currently active, channel 1 (one) is activated and displayed.</p> <ul style="list-style-type: none"> • MAIN Channels CHANNELS Channel Next

Table 4-2. Icon Descriptions - Listed Alphabetically (2 of 5)









Icon Name	Icon	Description
Icon Description Definitions		<p>Default Icons – These are one of the 10 default icons and are provided after a return to the factory standard configuration.</p> <p>Keyboard – If available, the keyboard shortcut to access this menu or function.</p> <p>Menu Bar – If available, navigation path to access this menu or function.</p> <p>Navigation – To navigate to this menu or function from the MAIN menu.</p> <p>Description – If available, where this menu, dialog box, or function is described in greater detail in this document.</p>
Display Icon	 Display	<p>Default Icon. Select displays the right-side DISPLAY menu.</p> <ul style="list-style-type: none"> • Keyboard: Alt + 4, then 2 • MENU BAR Trace Display • MAIN Trace TRACE
Easy Test Icon	 Easy Test	<p>Select displays the Easy Test dialog box used to load Easy Test scripts. A separate easyTest Tools PC application is used to generate the easyTest work instruction (ETT) files that are loaded by this icon. To get the easyTest tools PC application, download the installer from the Anritsu website.</p> <ul style="list-style-type: none"> • Keyboard ALT + 8 then 9 • Menu Bar Utilities EasyTest
File Icon	 File	<p>Select displays the right-side FILE menu.</p> <ul style="list-style-type: none"> • Keyboard: ALT + 1 • MAIN File FILE
Freq Icon	 Freq	<p>Default Icon. Select displays the right-side FREQUENCY menu.</p> <ul style="list-style-type: none"> • MAIN Frequency FREQUENCY
Help Icon	 Help	<p>Select displays the help menu from the MENU BAR</p>
Hold Icon	 Hold	<p>Select pauses the system operation, retaining all system presets and current configuration settings.</p> <ul style="list-style-type: none"> • MAIN Sweep Setup SWEEP SETUP Hold Functions HOLD FUNCTIONS Hold
Marker->Max Icon	 Marker->Max	<p>Displays marker with maximum value.</p> <ul style="list-style-type: none"> • MAIN Marker MARKER [1] Marker Search MARKER SEARCH Max
Marker->Min Icon	 Marker->Min	<p>Select displays the marker with minimum value.</p> <ul style="list-style-type: none"> • MAIN Marker MARKER [1] Marker Search MARKER SEARCH Min

Table 4-2. Icon Descriptions - Listed Alphabetically (3 of 5)









Icon Name	Icon	Description
<i>Icon Description Definitions</i>		<p>Default Icons – These are one of the 10 default icons and are provided after a return to the factory standard configuration.</p> <p>Keyboard – If available, the keyboard shortcut to access this menu or function.</p> <p>Menu Bar – If available, navigation path to access this menu or function.</p> <p>Navigation – To navigate to this menu or function from the MAIN menu.</p> <p>Description – If available, where this menu, dialog box, or function is described in greater detail in this document.</p>
Marker->Off Icon	 Marker->Off	<p>Select turns all marker displays off.</p> <ul style="list-style-type: none"> MAIN Marker MARKER [1] Marker Setup MARKER SETUP All Markers Off
Marker->Peak Icon	 Marker->Peak	<p>Select displays marker with the highest peak value.</p> <ul style="list-style-type: none"> MAIN Marker MARKER [1] Marker Search MARKER SEARCH Peak PEAK Search Peak
Marker->Pk Lft Icon	 Marker->Pk Lft	<p>Select displays the next peak value marker to the left of current selected marker.</p> <ul style="list-style-type: none"> MAIN Marker MARKER [1] Marker Search MARKER SEARCH Peak PEAK Search Left
Marker->Pk Rt Icon	 Marker->Pk Rt	<p>Select moves the current active marker to the next trace peak value to the right of its current position.</p> <ul style="list-style-type: none"> MAIN Marker MARKER [1] Marker Search MARKER SEARCH Peak PEAK Search Right
Marker Icon	 Marker	<p>Default Icon. Select displays the right-side MARKERS [1] menu.</p> <ul style="list-style-type: none"> Keyboard: Alt + 4, then 4 MENU BAR Trace Marker MAIN Marker MARKER [1]
Measurement Icon	 Measurement	<p>Select displays the right-side MEASUREMENT menu.</p> <ul style="list-style-type: none"> Keyboard: ALT + 6 MENU BAR Measurement MEASUREMENT MAIN Measurement
Power Icon	 Power	<p>Default Icon. Select displays the right-side POWER menu.</p> <ul style="list-style-type: none"> MAIN Power POWER
Preset Icon	 Preset	<p>Default Icon. Select returns the system to its prior preset status which is the status at the time of the last preset save.</p> <ul style="list-style-type: none"> Keyboard: Alt + 8, then 5 MENU BAR Utilities Preset

Table 4-2. Icon Descriptions - Listed Alphabetically (4 of 5)











Icon Name	Icon	Description
Icon Description Definitions		<p>Default Icons – These are one of the 10 default icons and are provided after a return to the factory standard configuration.</p> <p>Keyboard – If available, the keyboard shortcut to access this menu or function.</p> <p>Menu Bar – If available, navigation path to access this menu or function.</p> <p>Navigation – To navigate to this menu or function from the MAIN menu.</p> <p>Description – If available, where this menu, dialog box, or function is described in greater detail in this document.</p>
Print Icon	 Print	<p>Select displays the PRINT dialog box, usually to print a copy of the main display. Once the dialog box appears, click OK to print; click Cancel to abort.</p> <ul style="list-style-type: none"> • Keyboard: ALT + 1, then P • MENU BAR File Print • MAIN File FILE Print PRINT Dialog Box
Response Icon	 Response	<p>Default Icon. Select displays the right-side RESPONSE menu.</p> <ul style="list-style-type: none"> • Keyboard: Alt + 4, then 1 • MENU BAR Trace Response • MAIN Response RESPONSE
Scale Icon	 Scale	<p>Default Icon. Select displays the right-side SCALE menu.</p> <ul style="list-style-type: none"> • Keyboard: Alt + 4, then 3 • MENU BAR Trace Scale • Main Scale SCALE
Sweep Icon	 Sweep	<p>Select displays the right-side SWEEP SETUP menu.</p> <ul style="list-style-type: none"> • MAIN Sweep Setup SWEEP SETUP
System Icon	 System	<p>Select displays the right-side SYSTEM menu.</p> <ul style="list-style-type: none"> • Keyboard: Alt + 8, then 1 • MENU BAR Utilities System • MAIN System SYSTEM
Time Domain Icon	 Time Domain	<p>Select displays the right-side Time Domain menu.</p> <ul style="list-style-type: none"> • MAIN Time Domain
Trace Icon	 Trace	<p>Default Icon. Select displays the right-side TRACE menu.</p> <ul style="list-style-type: none"> • Keyboard: Alt + 4, then 5 • MENU BAR Trace Trace Menu • MAIN Trace TRACE
Tr->Max Icon	 Tr->Max	<p>Select maximizes the display with the currently active trace.</p> <ul style="list-style-type: none"> • Keyboard: Alt + 4, then 6 • MENU BAR Trace Trace Max • MAIN Trace TRACE Trace Max

Table 4-2. Icon Descriptions - Listed Alphabetically (5 of 5)

Icon Name	Icon	Description
<i>Icon Description Definitions</i>		<p>Default Icons – These are one of the 10 default icons and are provided after a return to the factory standard configuration.</p> <p>Keyboard – If available, the keyboard shortcut to access this menu or function.</p> <p>Menu Bar – If available, navigation path to access this menu or function.</p> <p>Navigation – To navigate to this menu or function from the MAIN menu.</p> <p>Description – If available, where this menu, dialog box, or function is described in greater detail in this document.</p>
Tr->Previous Icon	 Tr->Previous	Select displays the next lower trace number. When the lowest number is reached, next click displays the highest numbered trace. <ul style="list-style-type: none"> • Keyboard: Alt + 4, then 7 • MENU BAR Trace Trace Prev. • MAIN Trace TRACE Trace Previous
Tr->Next Icon	 Tr->Next	Select displays the next higher trace number. When the highest number is reached, next click displays lowest trace number. <ul style="list-style-type: none"> • Keyboard: Alt + 4, then 8 • MENU BAR Trace Trace Next • MAIN Trace TRACE Trace Next

CUSTOMIZE TOOLBAR Dialog Box

Use the CUSTOMIZE TOOLBAR dialog box to setup the Icon Toolbar with the icons you need for quick access to commands and functions. Once configured, and after a Preset Configuration save, the Icon Toolbar settings can be recalled with the other preset configuration parameters.

Previous

- [“UTILITIES Drop-Down Menu” on page 4-13](#)

Keyboard

- ALT + 8, then 3

Navigation

- MENU BAR | Utilities | Customize Toolbar | CUSTOMIZE TOOLBAR Dialog Box

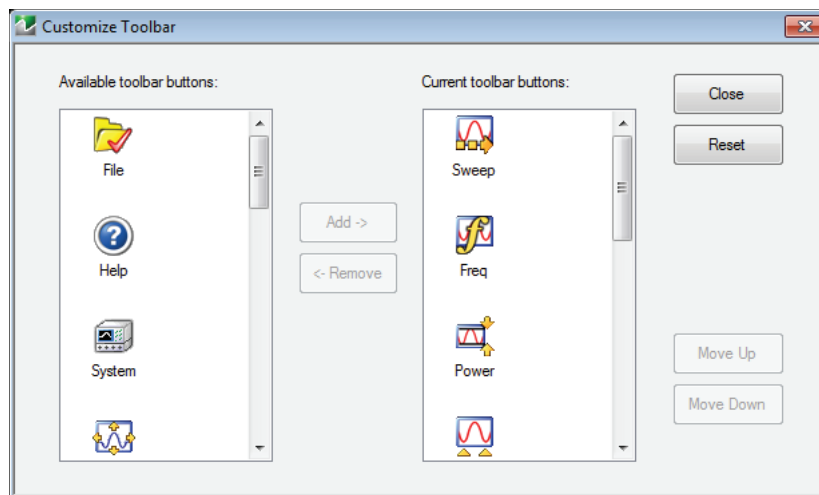

Figure 4-8. CUSTOMIZE TOOLBAR Dialog Box

Procedure

With the CUSTOMIZE TOOLBAR dialog box open, the left-side Available Toolbar Buttons area shows icons that are not in use on the current toolbar, while the right-side Current Toolbar Buttons area shows the current in-use icons.

Removing Icons

1. To change the icons in the current icon toolbar, in the right side Current button area, select an icon to remove. When selected, the Add-> and <-Remove buttons become available.
2. Remove unwanted icons as required by selecting the icon and then clicking the <-Remove button.
3. Removed icons appear at the bottom of the Available Toolbar Buttons list.

Adding Icons

1. Scroll through the Available Toolbar Buttons list and select an icon to add, then click the Add-> button. The selected icon appears in the right side Current Toolbar Buttons area.
2. Repeat the selection process until all required icons listed in the right side Current Toolbar Buttons area or you have reached the maximum of 10 icons.
3. In the Current Toolbar Button display, the icon displayed at the top of the list will appear on the extreme left of the toolbar. The tenth icon displayed at the bottom of the list will appear on the extreme right of the toolbar.

Moving Icons

To change the left to right sequence of the current icons, select an icon, and click the Move Up/Move Down buttons until the icons are correctly positioned left to right.

Saving the Configuration

When the icons are in the correct sequence. Click the Close button to apply the icons to the icon toolbar. It is recommended that a Preset Save be performed to save the icon toolbar configuration. If the icon toolbar needs adjustment, re-open the Customize Toolbar dialog box and repeat the steps above.

Reset to Factory Default

To return the icon toolbar to its factory default state, click the Reset button.

4-5 MAIN Menu and Application Menus

This section summarizes the MAIN MENU which is the home menu for all right-side menu interface menus, dialog boxes, and functions.

Note that if the height of the MAIN MENU exceeds that of your monitor display, a scroll bar will appear to provide vertical navigation.

MAIN Menu

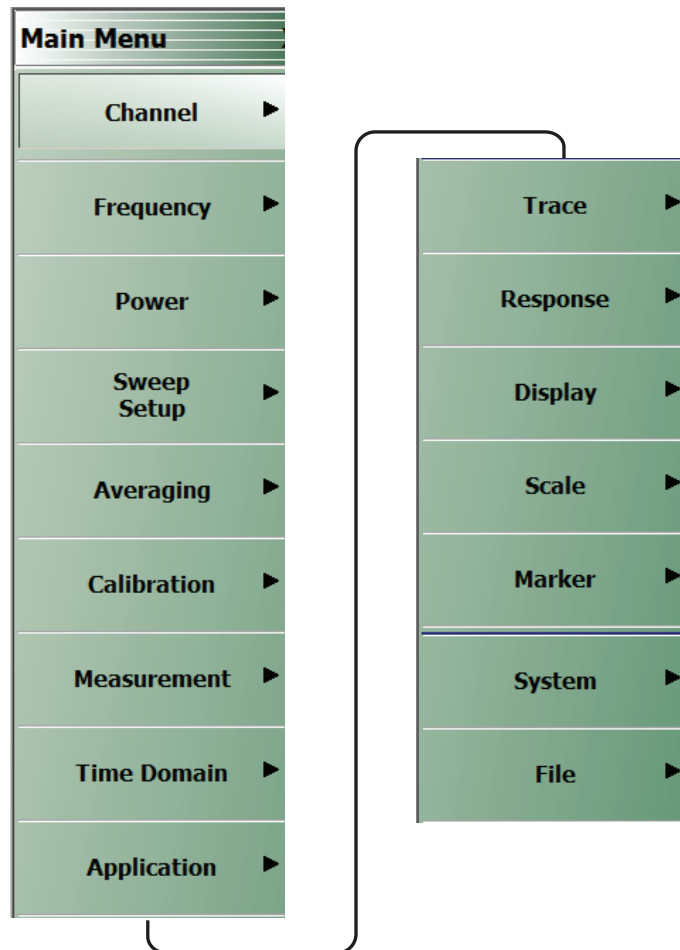

Figure 4-9. MAIN Menu

Channels

Select displays the CHANNELS menu. See the **User Interface Reference Manual** for descriptions of the CHANNEL menu.

Frequency

Select displays the FREQUENCY menu. The name, appearance, and available buttons on the FREQUENCY menu varies depending on the sweep type set and if CW frequency is selected.

Power

Select displays the POWER menu.

Sweep Setup

Select displays the SWEEP SETUP menu.

Averaging

Select displays the AVERAGING menu.

Calibration

Select displays the CALIBRATION menu.

Measurement

Select displays the MEASUREMENT menu.

Time Domain

Select displays the TIME DOMAIN menu

Application

Select displays the APPLICATION menu.

Trace

Select displays the TRACE menu.

Response

Select displays the RESPONSE menu.

Display

Select displays the DISPLAY menu.

Scale

Select displays the SCALE menu which allows the user to change the scaling and other attributes of a trace display.

SCALE menu variants are dependent on selections made from TRACE FORMAT menu options.

Marker

Select displays the MARKER [1] menu.

System

Select displays the SYSTEM menu.

File

Select displays the FILE menu.

4-6 Using the Main Menu Interface

Types of Menus, Menu Buttons, and Menu Toolbars

The Main Menu (or MAIN) is the right-side navigation function for the instrument. The Main Menu has multiple types of menus, menu buttons, and menu toolbars that allow the user to configure and control the operation of the VNA. Each menu consists of the elements shown in the figure below.

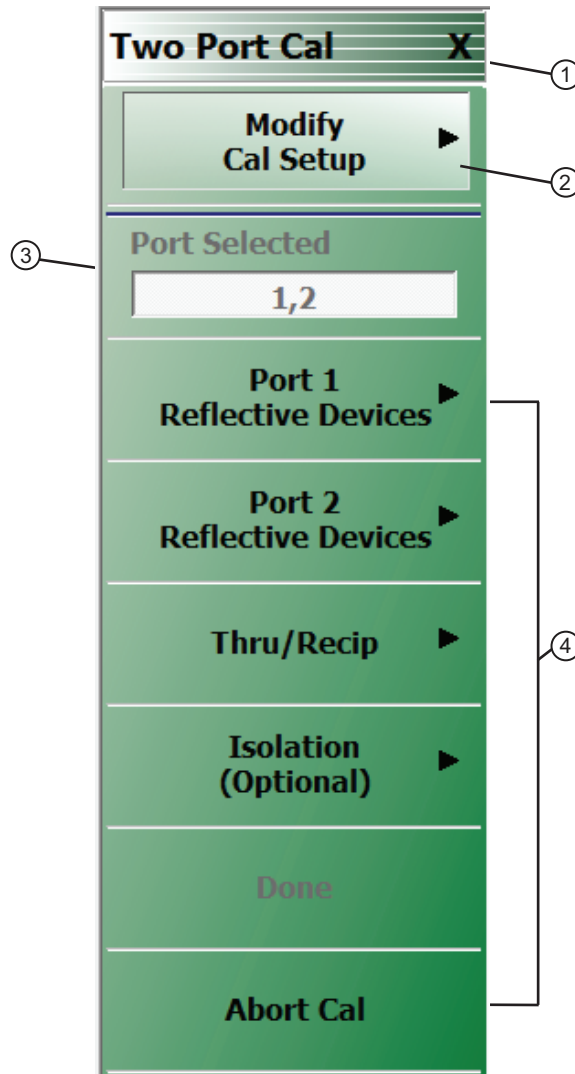

1. Menu Title – Each menu title is unique.	3. Field Buttons – The button shows the currently selected value. Selecting the button displays a field toolbar.
2. Active Selection	
	4. Menu Buttons – Displays a menu or dialog box.

Figure 4-10. Menu and Button Components

Menu Title

At the top of the menu, a unique menu title, which is not repeated on any other menu. For space reasons, menu names are often abbreviated. For definitions, see [Appendix C, “Abbreviation Glossary”](#).

Menu Buttons

One or more menu buttons that either call a sub-menu, allow for a field value to be specified, toggle a function off or on, or allow a selection to be made from a group of choices. If the menu is longer than one screen, a scroll box and scroll arrows appear on the right side of the menu.

Menu Navigation Buttons

The menu navigation area buttons appear at the bottom of each menu.

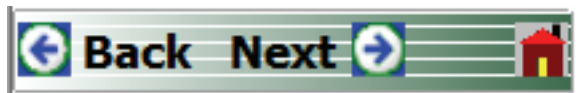

Back Button

The Back button returns the menu display to last selected higher-level menu.

Next Button

The Next button returns the menu display to the next deeper sub-menu that has already been selected. The availability of the Back and Next buttons (above) depends on the user's navigation path. The Home button (below) always appears.

Home Button

The Home button returns the menu display to the MAIN menu.

Menu Buttons

Menu buttons call lower-level menus.

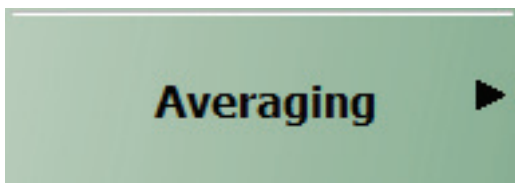

For example, the Averaging button on the MAIN menu calls the AVERAGING menu.

Read-Only Buttons

Read-only buttons display system values based on other settings and parameters.

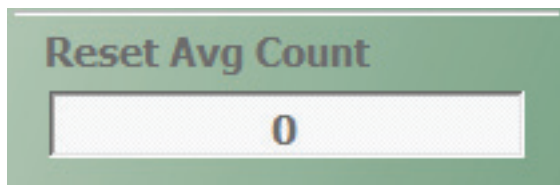

For example, the Reset Avg Count button is in a read-only state because the Averaging button is set to OFF.

Function Buttons

Function buttons are used to start a process or to select an option. The buttons are highlighted to indicate selection. Selected options display a radio button icon.



Toggle Buttons

Toggle buttons toggle through two or more values with each click of the button and display their current setting in the button field. For example, in the MAIN MENU | Response | RESPONSE | User Defined | USER DEFINED menu, the Driver Port button displays the default Port 1 setting.



Clicking the Driver Port button toggles to the Port 2 setting.



Clicking the Driver Port button a second time toggles back to the Port 1 setting.



Field Selection Buttons

Field selection buttons display a user-defined parameter or value. Clicking a field selection button such as the Start button on the FREQUENCY menu displays a field toolbar (described below) that allows the user to specify parameter values and units.

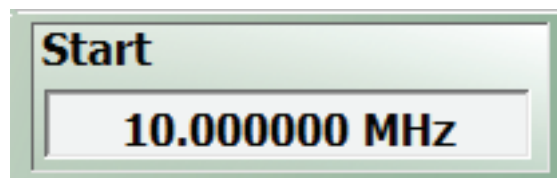

Field Toolbars

Field toolbars appear under the Icon Toolbar after the associated field button has been selected. The field toolbar displays its name, a value field, up/down arrows to increment the value, and one or more unit select buttons.

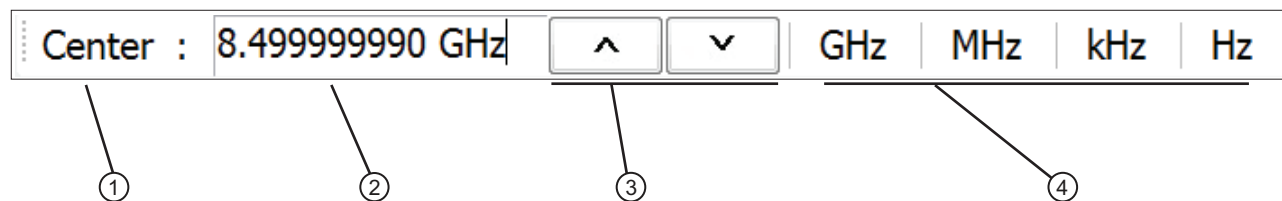

- | | |
|--|---|
| <ol style="list-style-type: none"> 1. Toolbar Name – The toolbar name usually is based on the name of the button that called the toolbar. 2. Value Field – Entry area for parameter value. Entry can be from the front panel Number Keys, or from an attached USB keyboard, or by clicking the Up/Down arrows (below). | <ol style="list-style-type: none"> 3. Up/Down Arrows – Increments the value field up or down to quickly enter values. The same effect from the front panel Up/Down Arrow Keys, or from the keyboard Up/Down arrow keys. 4. Available Units Selection – If available (shown in the upper toolbar), allows the selection of units from two or more values. If not available (shown in the lower toolbar), the units are fixed and not selectable. |
|--|---|

Figure 4-11. Field Toolbar Selections

For example, clicking the Start button on the FREQUENCY menu displays the Start (Frequency) field toolbar, with multiple frequency options.



Some field toolbars display a single unit with no options. For example, in the MAIN MENU | Scale | SCALE menu, clicking the Reference Value button displays the Reference Value toolbar with a single dB unit value option.



The system limits for each toolbar are defined in the System Limits section in the Programming Manual Supplement. The appendix lists the default, minimum allowable, and maximum allowable values and whether the toolbar changes apply on a per-trace, per-channel, or per-system basis.

Auto-Return Button Groups

Auto-return groups are button selection groups (described above) that automatically return to the higher-level menu after a selection is made.

For example, on the TRACE FORMAT menu shown below (1), clicking on the Impedance button displays the IMPEDANCE menu with its current selection of Real (2). When another selection such as Real & Imaginary is made (3), the system auto-returns to the TRACE FORMAT menu with the Impedance button now set to Real & Imaginary (4).

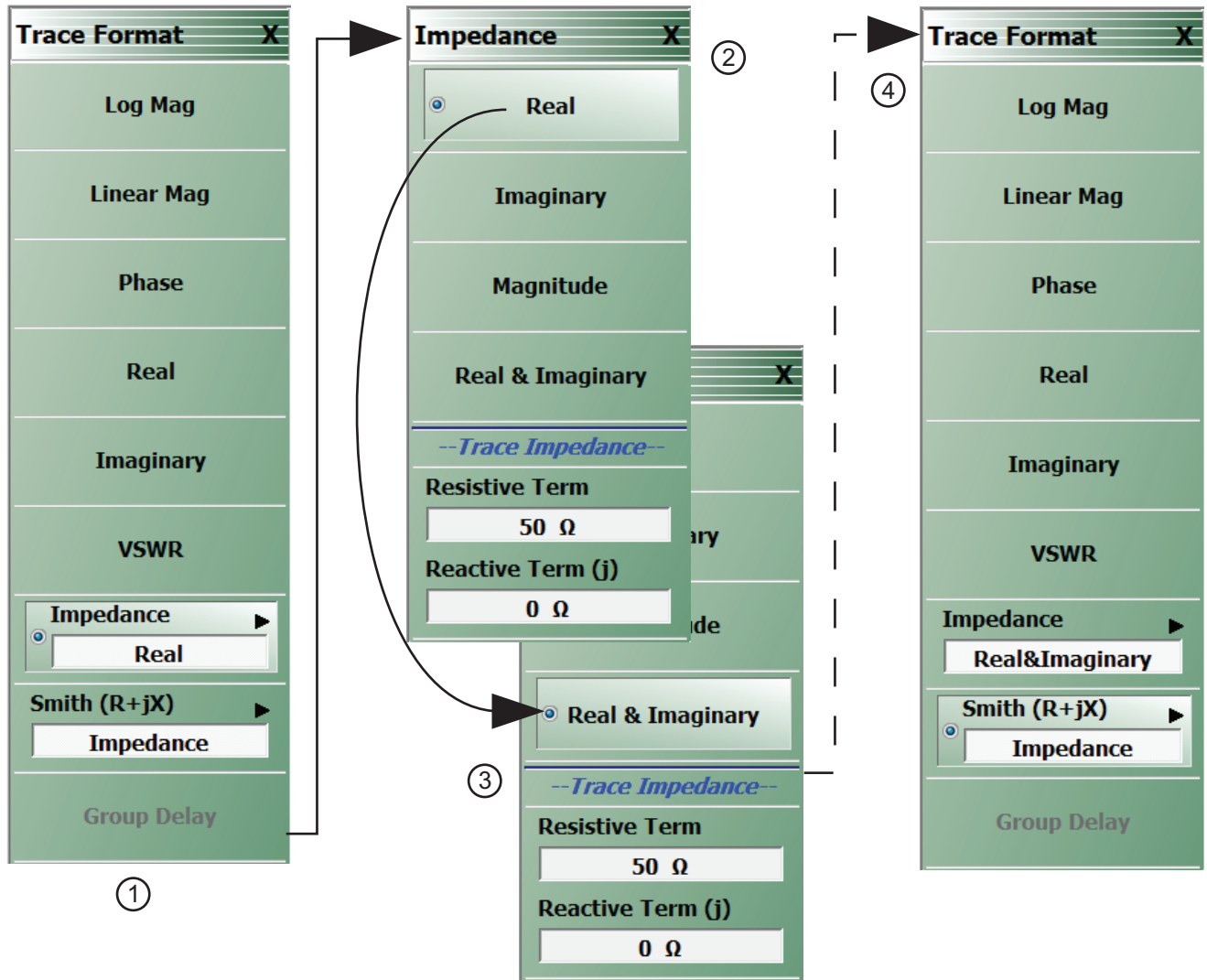

- | | |
|--|--|
| <ol style="list-style-type: none"> Original TRACE FORMAT Menu with Impedance setting as "Real" <ul style="list-style-type: none"> The bottom Impedance field button is set to "Real" Clicking the Impedance button displays the IMPEDANCE menu. Original IMPEDANCE Menu with "Real" <ul style="list-style-type: none"> The IMPEDANCE menu appears with impedance set as "Real." | <ol style="list-style-type: none"> IMPEDANCE Menu with "Real & Imaginary" <ul style="list-style-type: none"> The user selects "Real & Imaginary" and the system auto-returns to the TRACE FORMAT menu. Modified TRACE FORMAT Menu with Impedance setting as "Real & Imaginary" <ul style="list-style-type: none"> The TRACE FORMAT menu automatically re-appears with impedance set as "Real & Imaginary." |
|--|--|

Figure 4-12. Auto-Return Button Group Example on the IMPEDANCE Menu

Completion Checkmark Button

In the **Calibration** menus, some buttons list the required tasks for each calibration type. The completion checkmark icon indicates that a calibration task has been completed.



For example, in a Full 2 Port Reflection Calibration, one of the required steps is a Port 1 Short test.



The button above left shows the test has not been started. The user makes the necessary physical connections between the VNA and the required connector/adaptor, and then clicks the button to begin the test. The button dims while the test is performed. After the test is successfully completed, the completion icon appears on the left side of the button as shown above right.

4-7 Using Dialog Boxes

Most dialog boxes are standard Microsoft dialog boxes and appear in the center of the display area.

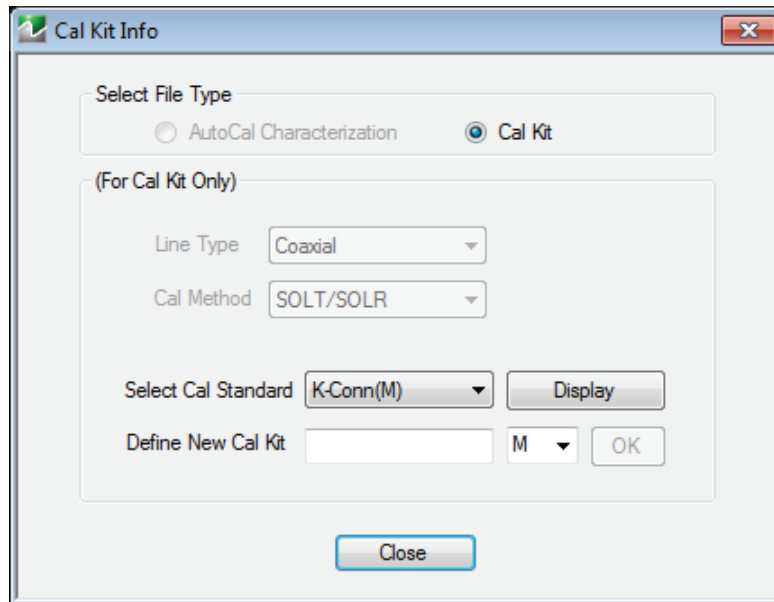

Figure 4-13. CAL KIT INFO Dialog Box Example

Standard Dialog Box Buttons

Most dialog boxes also have some combination of standard buttons for OK, Cancel, and Save. Other buttons and types of buttons may be present. Within dialog boxes are **Dialog Box Areas** that are usually named for the options that can be selected or the information that is displayed. For example, in the figure above, test status and completion messages are displayed in the **Self Test Message** area. Most **Dialog Box Areas** are delimited by a line, box, or shadowbox that contains the information or settings for a series of common attributes. If the area is named in the dialog box, that name is used in any related procedures. If the area is not named, the area is named for the first data or input field. Some dialog boxes have links that call sub-dialog boxes.

4-8 Instrument Status Display Area

At the bottom of the instrument display is the status bar where instrument states and conditions are reported.

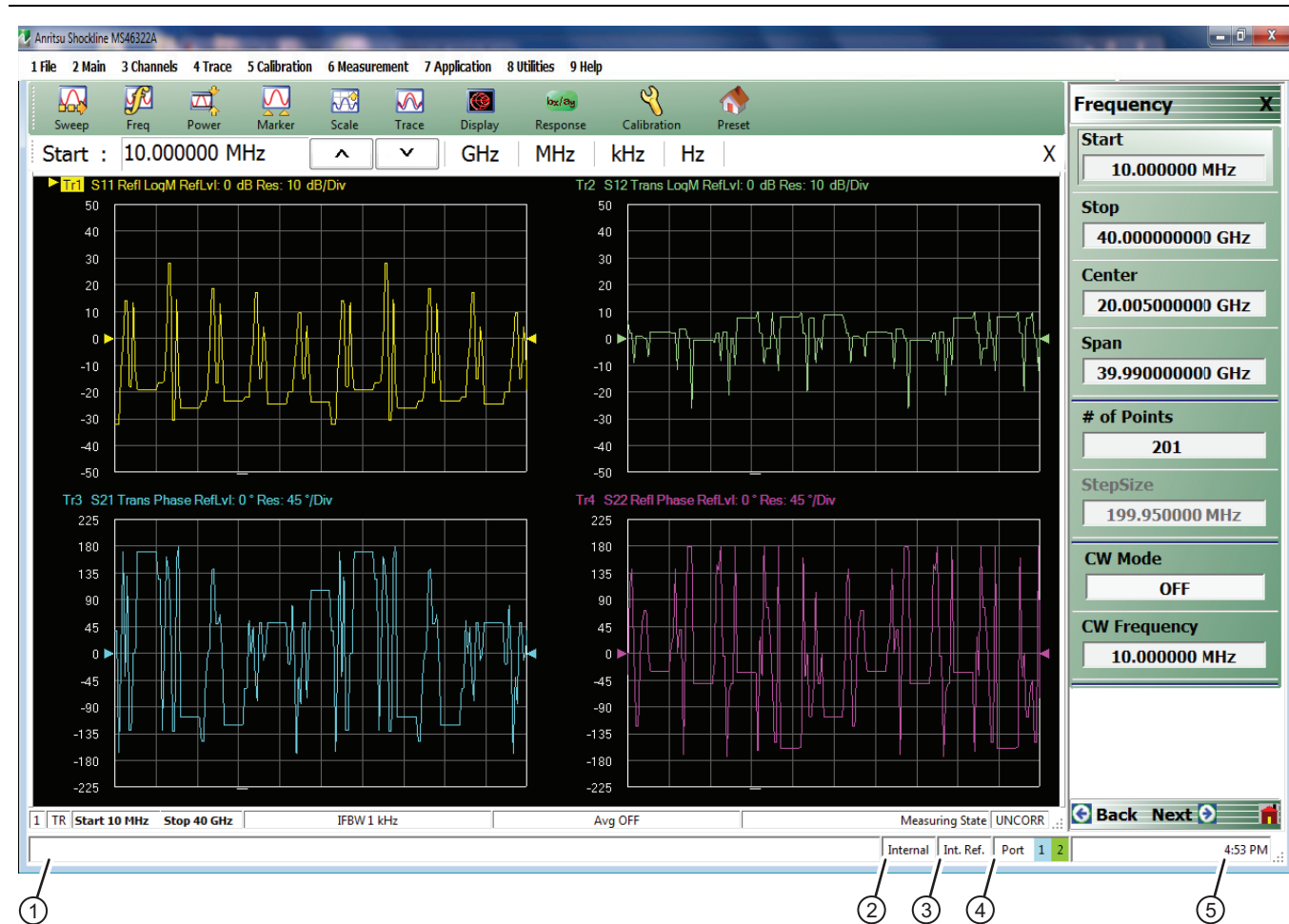

Figure 4-14. Instrument Status Area

Instrument Status Data

Table 4-3. Instrument Status Display Abbreviations

Status Display	Description
1. Warning Messages	Displays warning messages.
2. Internal / External / Manual	Displays status of system triggering.
3. Int. Ref. / Ext. Ref.	Indicates usage of internal or external reference.
4. Port 1 / Port 2 / Port 3 / Port 4	Highlights the port being driven: <ul style="list-style-type: none"> • 2-Port VNAs cycle between Port 1 and 2. • 4-Port VNAs cycle between 1 and 4.
5. Time	Displays system time.

4-9 Instrument Status Display Area

At the bottom of the display is the instrument status bar where the following information is reported. The displayed parameters are context and setting dependent. Not all parameters are displayed all the time. In a multi-channel display, the display may be truncated. To maximize the channel display, select any of the following:

- Keyboard: **CTRL + 1**
- Keyboard: **ALT + 3, then 2**
- MAIN | Channels | CHANNELS | Chan. Max

Table 4-4. Status Bar Abbreviations

Status Display	Description
TR	Displays the measurement mode as transmission/reflection.
Ch#	Displays the channel number. For example, Ch2 means that the display is for Channel 2.
[Start]	In general, the left-side parameters define the starting position of distance, frequency, time, or power.
[End]	In general, the right-side parameters define the ending position of distance, frequency, time, or power.
CW Frequency # Units	From the FREQUENCY menu, if CW Mode is set to on, displays the current CW Frequency value with units of kHz, MHz, or GHz.
Start # Units	From the FREQUENCY menu, if CW Mode is set to off, displays the current Start Frequency value with units of kHz, MHz, or GHz.
Stop # Units	From the FREQUENCY menu, if CW Mode is set to off, displays the current Stop Frequency value with units of kHz, MHz, or GHz.
# Units	From the AVERAGING menu, reports the Frequency setting with units of Hz, kHz, or MHz.
Avg OFF	From the AVERAGING menu, reports that Averaging is off, or if values are present, Averaging is on.
Avg #	If Averaging is on, and the Averaging Type is Per-Point, reports the Averaging factor.
# / #	If Averaging is on, and the Averaging Type is Per-Sweep, the left-side number reports the number of average sweeps; the right-side number displays the Averaging Factor.
Measuring State Calibrating State	Indicates whether the instrument is measuring or being calibrated.
UNCORR CORRECTED	UNCORR (with a dark gray background) indicates that a calibration is not being applied. CORRECTED (with a green background) indicates that the calibration for the active channel is being applied.

4-10 Working with Channels

Each VNA channel is like a separate VNA, with its own frequency list, calibrations, power setup and other parameters. Each channel can display up to 16 individual trace graph displays. The number of VNA channels is user-definable up to a maximum of 16 channels.

4-11 Working with Traces

Types of Trace Displays

For each channel defined above, from 1 (one) to 16 trace graphs (called “traces”) can be defined where each trace is a data display within a specific channel. Each trace is defined by a response parameter (such as S11), a graph type display (such as a rectilinear graph, a polar display or Smith chart), a scale, and possibly post-processing elements such as time domain and smoothing. There are four general graph types available and within each general type are multiple sub-types:

- Rectilinear single graph
- Rectilinear dual graph
- Smith chart
- Polar plot graph

Trace Data Types

The data types generated by the VNA (real, imaginary, magnitude, phase) are used in the display graph to show the possible ways in which S-Parameter data can be represented. For example, complex data, that is data in which both phase and magnitude are graphed, may be displayed in any of the following ways:

- **Complex Impedance**

Displayed on a Smith chart graph as impedance or as admittance.

- **Real and Imaginary**

If simultaneous displays are required, displayed on a real and imaginary rectilinear (a Cartesian plot) graph. If only one type is required, a single rectilinear real graph or single rectilinear imaginary graph.

- **Phase and Magnitude**

Displayed on a single rectilinear graph, as paired rectilinear graphs, or as a polar graph.

- **Group Delay**

Defined as the frequency span over which the phase change is computed at a given frequency point. The quantity group delay is displayed using a modified rectilinear-magnitude format. In this format, the vertical scale is in linear units of time (either ps, ns, us, or ms). With one exception, the reference value and reference line functions operate the same as they do with a normal magnitude display.

Trace Display Graphs

A separate graph can be assigned to each active channel and display area. The following available display graph types are listed in [Table 4-5](#) below.

Table 4-5. Available Trace Display Types (1 of 3)

Menu Name	Definition and Display Options	Y-Axis Dependent Variable	X-Axis Independent Variable	Measurement Applications
Rectilinear Single Graphs				
Log Mag	Log magnitude rectilinear format graph Magnitude		Y = dB	Return loss measurement Insertion loss measurement Gain measurement
Linear Mag	Linear magnitude rectilinear format graph	Magnitude	Linear units	Reflection coefficient measurement
Phase	Phase rectilinear format graph	Phase displayed in range from -180 to +180 degrees	Degrees	Linear phase deviation measurements
Imaginary	Imaginary rectilinear format graph	Imaginary part of measured complex parameter	Linear units	
Real	Real rectilinear format graph	Real part of measured complex parameter	Linear units	
SWR	Standing Wave Ratio rectilinear format graph	$SWR = \frac{1 + \rho}{1 - \rho}$ where ρ = Reflection Coefficient	Linear units	Standing wave measurements Antenna analysis
Impedance	Impedance rectilinear format graph Four options are: <ul style="list-style-type: none"> • Real • Imaginary • Magnitude • Real & Imaginary • Inductance • Capacitance 			
Rectilinear Paired Graphs				
Log Magnitude and Phase	Paired graphs with Log Magnitude on top and Phase on bottom	As above	As above	Same as having one trace with a Log Magnitude display and a second trace with a Phase rectilinear display.

Table 4-5. Available Trace Display Types (2 of 3)

Menu Name	Definition and Display Options	Y-Axis Dependent Variable	X-Axis Independent Variable	Measurement Applications
Linear Magnitude and Phase	Paired graphs with Linear Magnitude on top and Phase on bottom	As above	As above	Same as having one trace with a Linear Magnitude display and a second trace with a Phase rectilinear display.
Real and Imaginary	Paired graphs with Real on top and Imaginary on bottom	As above	As above	Same as having one trace with a Real rectilinear display and a second trace with an Imaginary rectilinear display.
Polar Graphs				
Linear Polar	Linear polar plot graph The polar graph format traces are used to display one magnitude value and phase on the same chart. Plot options: • Lin/Phase • Real/Imag.		Chart mode options: • Magnitude/Phase • Magnitude/Swap Position	
Log Polar	Plot options: • Log/Phase • Real/Imag.		Chart mode options: • Magnitude/Phase • Magnitude/Swap Position	
Smith Chart Graphs				
Smith (R + jX)	Smith Chart graphs with impedance (circuit resistance and reactance) Four read out style options are available: • Lin/Phase • Log/Phase • Real/Imag. • Impedance		The impedance is the measure of a circuit's opposition to alternating current which consists of the circuit resistance and the circuit reactance, together they determine the magnitude and phase of the impedance.	• Reflection measurements
Group Delay / Power Graphs				

Table 4-5. Available Trace Display Types (3 of 3)

Menu Name	Definition and Display Options	Y-Axis Dependent Variable	X-Axis Independent Variable	Measurement Applications
Group Delay	Displays the time lag through a DUT measured in ps, ns, us, or ms.	Time measured in ps, ns, us, or ms.	Frequency	Bandpass filter design Transmission studies

Each graph type is described in greater detail below with sample graphs, and explanation of supporting trace displays.

Trace Labels

Each trace (i.e. each graph display) is labeled with information such as its trace number, the graph type, scaling, reference delay, and S-parameter associated with that trace. Depending on the trace settings and the graph type, other information may be displayed.

The general format of trace label consists of the following parameters and their associated abbreviations appearing from left to right in the trace label. Some parameters may not appear depending on the instrument settings.

- Trace Number
- Measurement Type
- Time Domain
- Graph Type
- Reference Level
- Resolution Units
- Trace Memory Statistics

Trace Label Abbreviations

The trace label abbreviations are described in the tables below:

- [Table 4-6, "Trace Labels - Trace Number, Measurement Type"](#)
- [Table 4-7, "Trace Labels - Abbreviation, Type and Name, Reference Level Units, Resolution Units"](#)

Table 4-6. Trace Labels - Trace Number, Measurement Type

Abbreviation	Definition	Description
Trace Number Abbreviation		
Tr#	Trace number	Trace 1 through Trace 16.
Measurement Type Abbreviations		
S11 Refl	S11 Port 1 forward reflection	S-parameters are selected on the RESPONSE menu.
S12 Trans	S12 Port 1 reverse transmission	
S21 Trans	S21 Port 2 forward transmission	
S22 Refl	S22 Port 2 reverse reflection	
NN / DD Port #	NN is user-defined numerator value. DD is user-defined denominator value. Port number	User-defined numerator, denominator, and driver port are selected on the RESPONSE User-defined USER-DEFINED menu. Numerator and denominator options are A1, B1, A2, B2, or 1. Port number selection options are Port 1 or Port 2.

Table 4-7. Trace Labels - Abbreviation, Type and Name, Reference Level Units, Resolution Units

Graph Abbreviation	Graph Name and Type	Reference Level (RefLvl)	Resolution Units (Res)
Rectilinear Single Graph			
LogM	Log Mag (Log Magnitude) rectilinear	dB	dB / Div
LinM	Linear Mag (Linear Magnitude) rectilinear	U	U / Div
Phase	Phase rectilinear with units in degrees (°)	°	° / Div
Real	Real rectilinear	U	U / Div
Imag	Imaginary rectilinear	U	U / Div
SWR	SWR rectilinear	U	U / Div
Imped Real	Impedance Real rectilinear with units in Ohms (Ω)	Ω	Ω / Div
Imped Imag	Impedance Imaginary rectilinear	Ω	Ω / Div
Imped Mag	Impedance Magnitude rectilinear	Ω	Ω / Div
Imped R + I	Impedance Real and Imaginary rectilinear. A rectilinear paired graph.	Ω	Ω / Div
Rectilinear Paired Graphs			
LogM + P	Log Magnitude and Phase rectilinear paired graphs.	dB	° Res: dB/Div, °/Div
LinM + P	Linear Magnitude and Phase rectilinear paired graphs	dB	° Res: dB/Div, °/Div
R + I	Real and Imaginary rectilinear paired graphs	U	Res: U/Div, U/Div
Smith Charts with Impedance			
Smith Imped	The display can be one of four possible Smith Chart with impedance displays: <ul style="list-style-type: none"> • Smith (R+jX) Linear/Phase Smith Chart • Smith (R+jX) Log/Phase Smith Chart • Smith (R+jX) Real/Imaginary Smith Chart • Smith (R+jX) Impedance Smith Chart 	—	U / Div
Polar Graphs			
Lin Pol	Linear Polar, Linear/Phase polar	U	U/Div
Lin Pol, RI	Linear Polar, Real/Imaginary polar	U	U/Div
Log Pol	Log Polar, Log/Phase polar	dB	dB/Div
Log Pol, RI	Log Polar, Real/Imaginary polar	dB	dB/Div
Group Delay and Power Rectilinear Graphs			
Grp Dly	Group Delay rectilinear with units of seconds	s	Res: s/Div

Rectilinear Single Graph

A rectilinear graph is a display of a Cartesian coordinate system or plan consisting of an X-axis and a Y-axis. The X-axis displays the independent variable (such as frequency or time) and the Y-axis displays the dependent value.

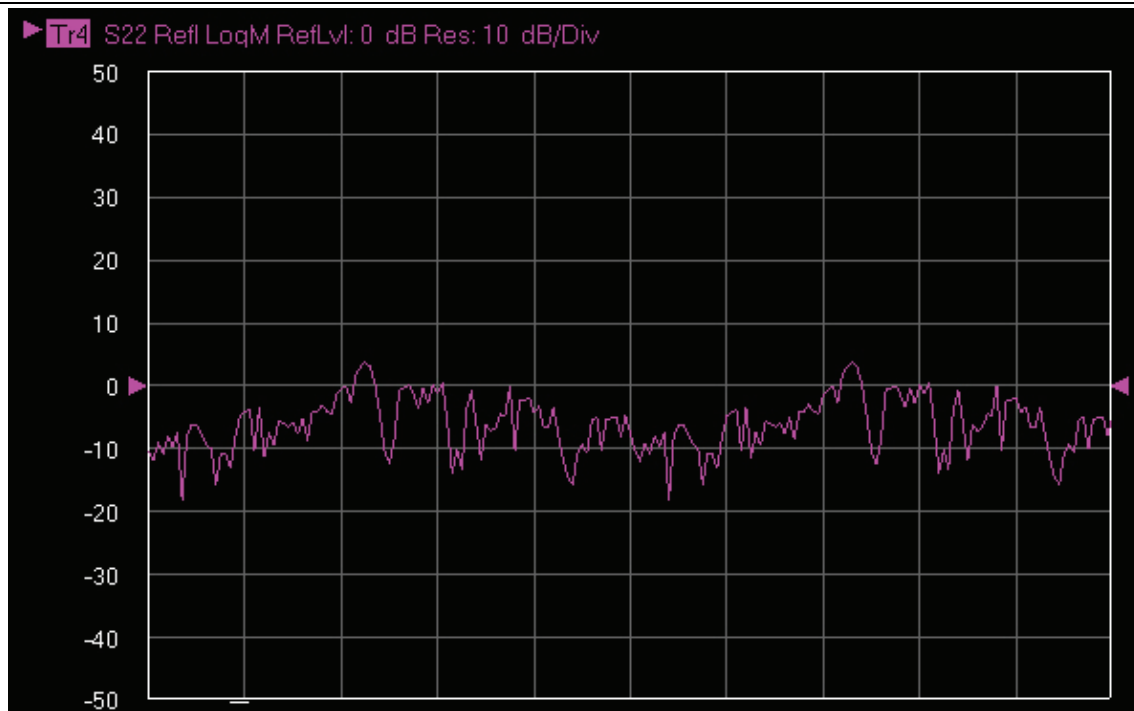

Figure 4-15. Trace Graph - Rectilinear Single - Log Magnitude (Log Mag) Trace Display Graph

Rectilinear Paired Graphs

As above, but paired with a phase rectilinear graph below. Useful to provide immediate comparison with a function value and its phase.

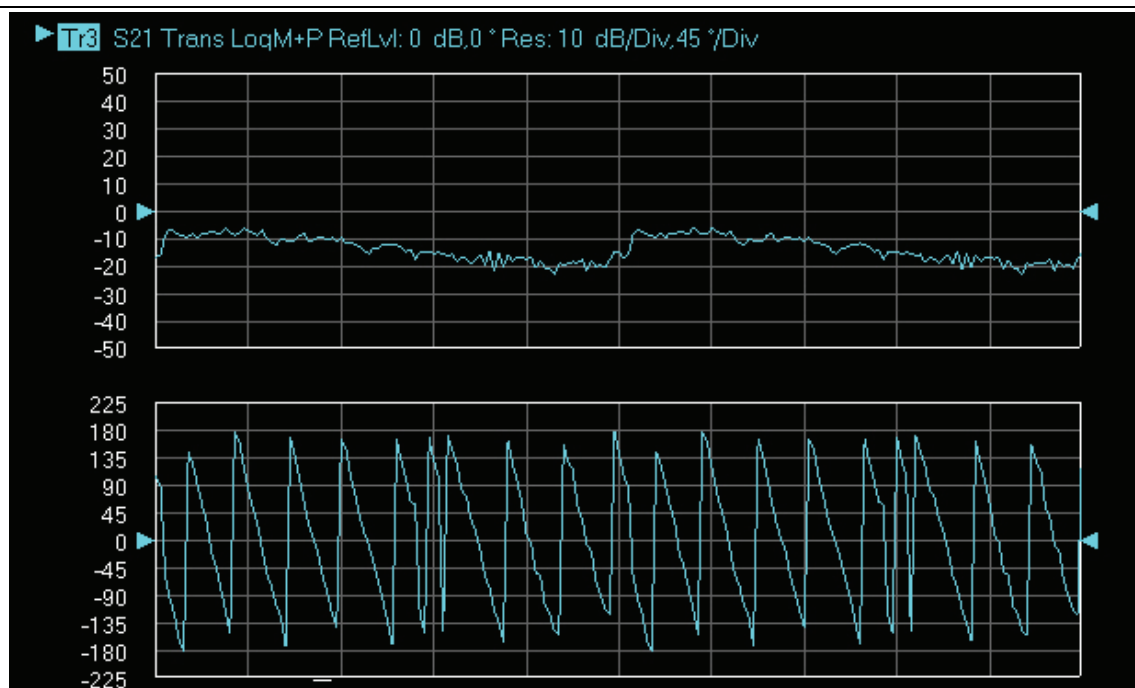

Figure 4-16. Trace Graph - Rectilinear Paired - Trace Log Magnitude and Phase Trace Display

Smith Charts

The power reflected from a DUT has both magnitude and phase because the impedance of the device has both a resistive and a reactive term of the form $r+jx$. We refer to the r as the real or resistive term, while we call x the imaginary or reactive term. The j , which we sometimes denote as i , is an imaginary number. It is the square root of -1 . If x is positive, the impedance is inductive, if x is negative the impedance is capacitive. The size and polarity of the reactive component x is important in impedance matching. The best match to a complex impedance is the complex conjugate which means an impedance with the same value of r and x , but with x of opposite polarity. This term is best analyzed using a Smith Chart, which is a plot of r and x .

To display all the information on a single S-parameter requires one or two traces, depending upon the format we want. A very common requirement is to view forward reflection on a Smith Chart (one trace) while observing forward transmission.

Smith Chart with Impedance (Circuit Resistance and Reactance)

The Smith Chart with impedance (Smith $R + jX$) has four display options:

- Lin/Phase
- Log/Phase
- Real/Imag.
- Impedance

The impedance is the measure of a circuit's opposition to alternating current which consists of the circuit resistance and the circuit reactance, together they determine the magnitude and phase of the impedance.

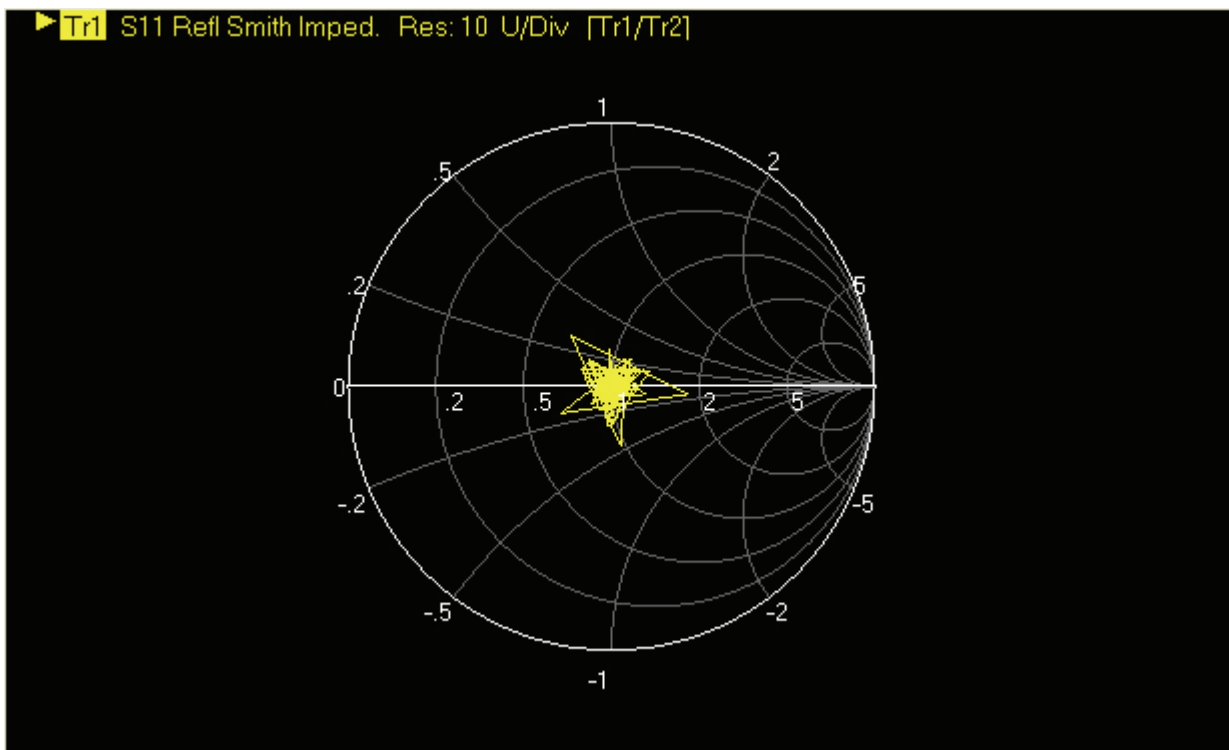

Figure 4-17. Smith Chart with Impedance ($R+jX$)

Polar Graphs

A polar graph represents a two-dimensional coordinate system where each point is determined by an angle and a distance. The polar coordinate system is especially useful in situations where the relationship between two points is most easily expressed in terms of angles and distance such as in phase relationships in antenna and feedline design. The magnitude parameter can use either a linear or log scale. As the coordinate system is two-dimensional, each point is determined by two polar coordinates: the radial coordinate (distance from the center) and the angular coordinate (degrees counterclockwise from the right edge). Polar displays are used for transmission measurements, especially for cascaded devices in series. The transmission result is the addition of the phase and log magnitude (dB) information in the polar display of each device.

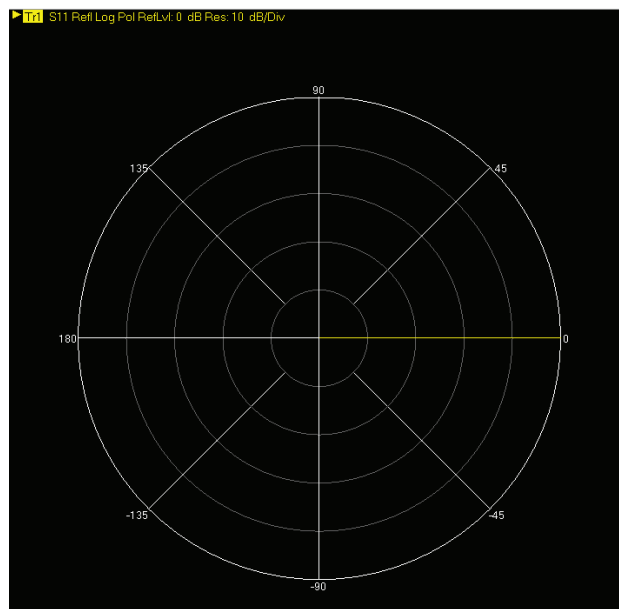
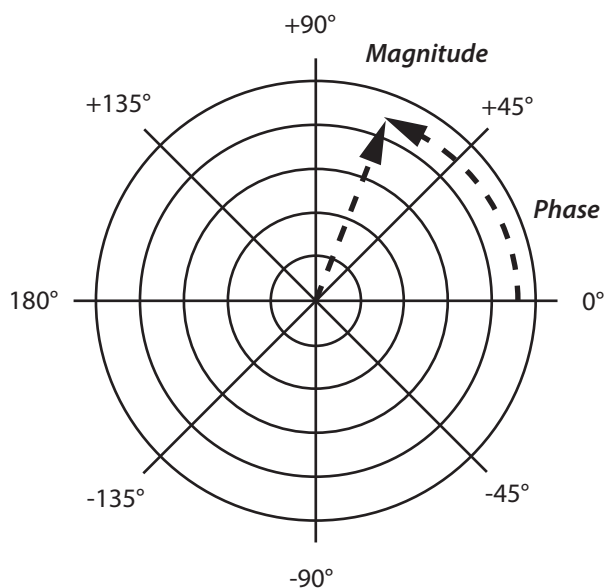

Figure 4-18. Log Polar Diagram and Trace Graph Example

Group Delay Graphs

The quantity group delay is displayed using a modified rectilinear-magnitude format. In this format the vertical scale is in linear units of time (ps, ns, us, ms). With one exception, the reference value and reference line functions operate the same as they do with a normal magnitude display. The exception is that they appear in units of time instead of magnitude.

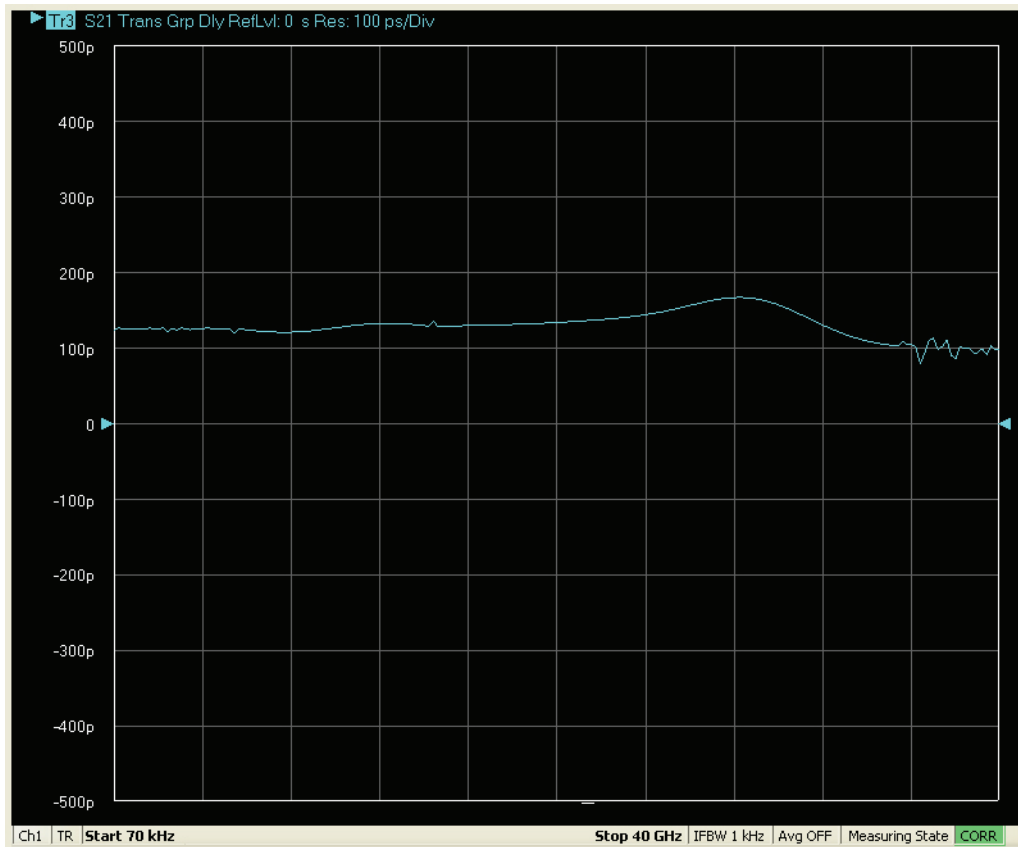
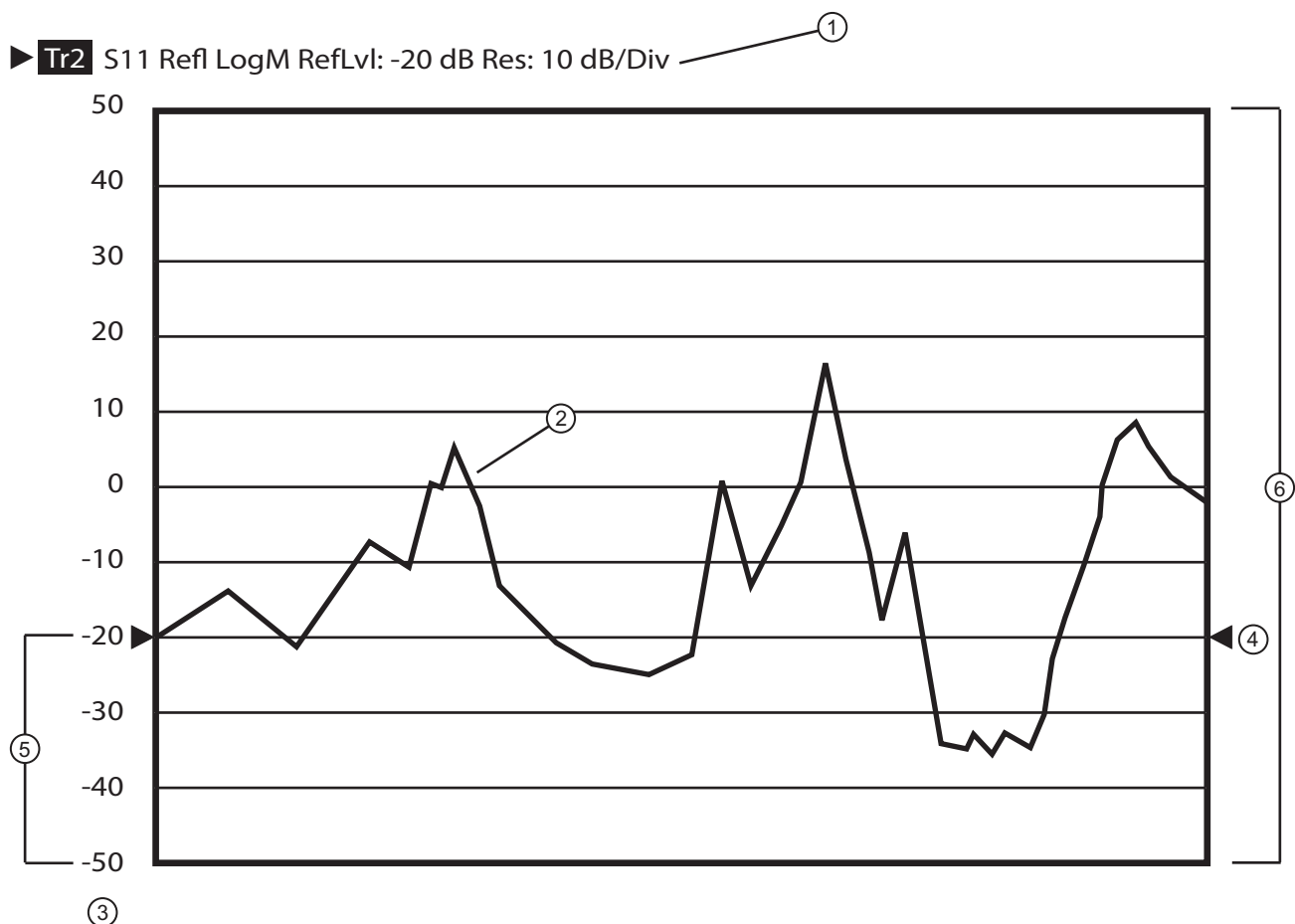

Figure 4-19. Group Delay Trace Graph Example

4-12 Working with Reference Lines and Reference Position

You can manipulate the display elements in a rectilinear trace graph from either the trace itself or from the right-side menus.



1. Trace Label – The trace label appears above the trace graph. The example above shows Trace 2 measuring S11, displayed on a Log Magnitude graph, with a Reference Level of -20 dB, and a graph resolution of 10 dB per vertical division.
2. Response Graph – A typical S11 response graph.
3. Resolution in Units per Division – The example shows 10 dB per division.
4. Reference Line Pointers – Reference lines are only available in rectilinear trace graphs and are indicated by the paired arrows on the trace graph display and show the position of the reference value on the Y-axis scale. The example Reference Value is set to -20 dB. Click-hold-and-drag the line pointers to change the reference line value.
5. Reference Position – The example Reference Position is set to 3. Click-hold-and-drag the reference position scale to change the position of the graph on the Y-axis up or down. The value of the Reference Line Points does not change.
6. Number of Vertical Divisions – The example number of vertical divisions is set to 10.

Figure 4-20. Trace Display Controls and Settings

4-13 Working with Limit Lines

Limit lines are a powerful tool to help compare a set of measured DUT data against specifications or expectations. Limit lines are:

- Can be configured as settable maximum and/or minimum indicators for the value of displayed data on a per-trace basis.
- Available only for ShockLine rectilinear and polar displays.
- Not available for ShockLine Smith charts.
- Settable in the basic units of each trace.
- Rescaled automatically and maintain their correct value if the trace display is rescaled.
- Are limited to a total of 50 segments (upper and lower combined) per-trace.
- For dual displays, such as the **Log Mag And Phase** display, the segment limit is 50 segments for the top display and 50 segments for the bottom display.

Appendix A — Vector Network Analyzer Primer

A-1 Appendix Overview

This chapter describes the basic functions of a Vector Network Analyzer (VNA) and how it measures magnitude and phase characteristics of networks, amplifiers, attenuators, and antennas. Scattering parameters (S-parameters) are defined.

This section provides front panel operating and measurement application information and data. It includes discussions on the following topics:

- System description
- General discussion about network analyzers
- Basic measurements and how to make them
- Error correction
- General discussion on test sets

A-2 General Description

The ShockLine MS46122A Series Vector Network Analyzer (VNA) System measures the magnitude and phase characteristics of networks, amplifiers, attenuators, and antennas. It compares the incident signal that leaves the analyzer with either the signal that is transmitted through the test device or the signal that is reflected from its input. [Figure A-1](#) and [Figure A-2](#) illustrate the types of measurements that the MS46122A Series VNA can make.

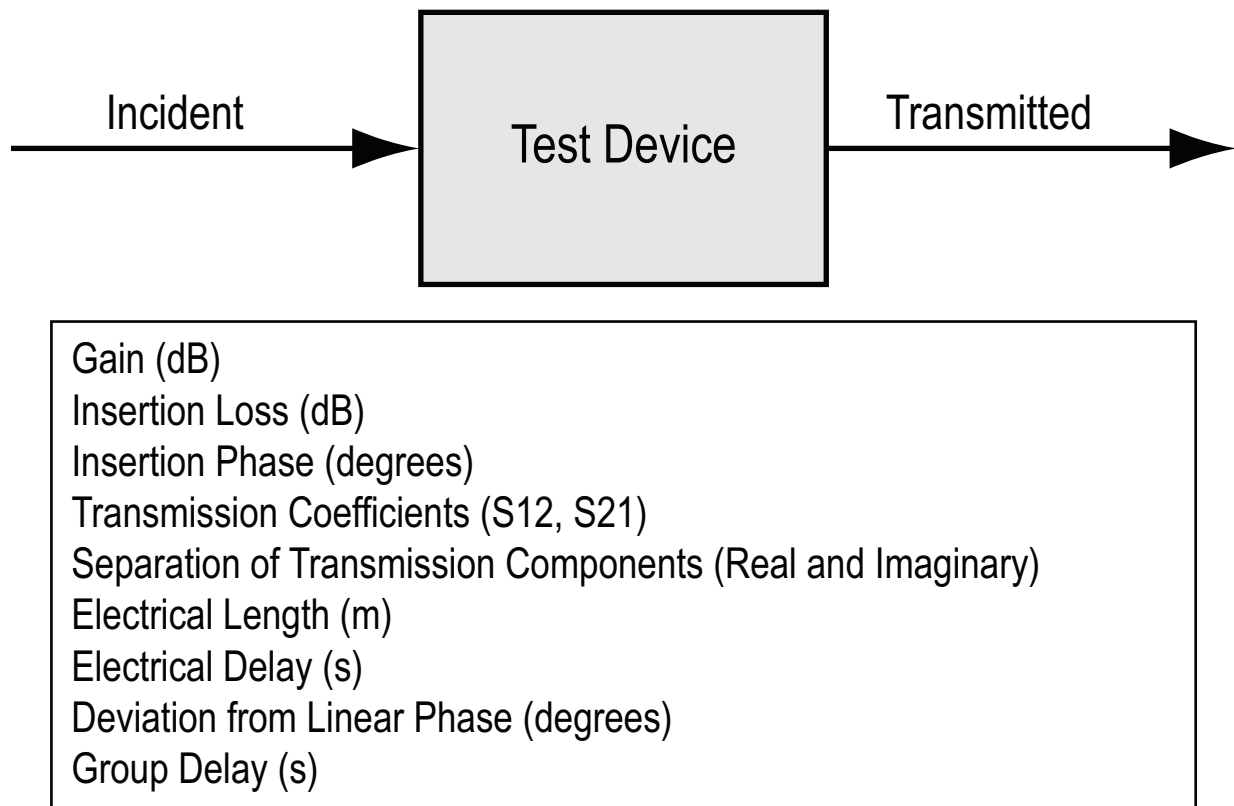

Figure A-1. Transmission Measurements

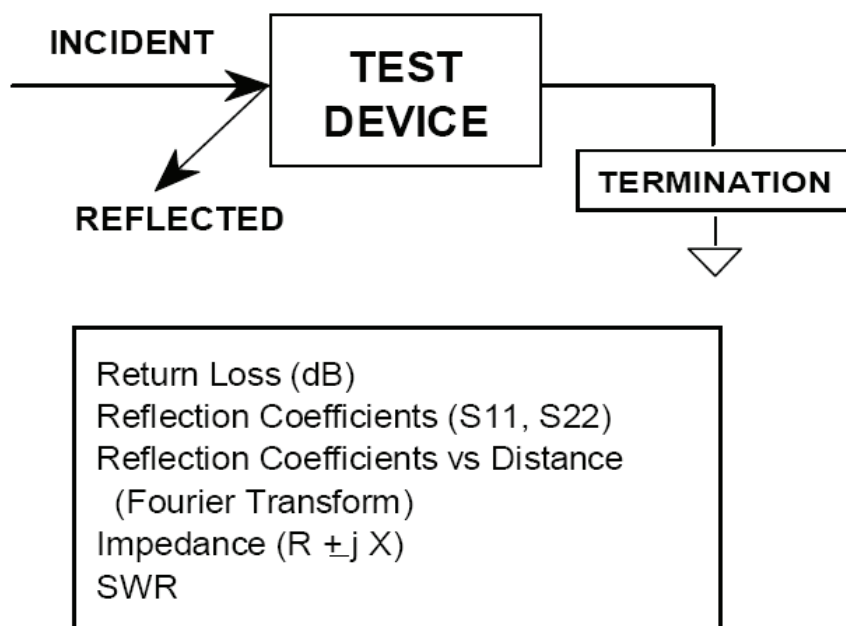

Figure A-2. Reflection Measurements

A-3 Instrument Description

The ShockLine MS46122A Series VNA is a self-contained, fully integrated measurement system that includes an optional time domain capability. The system hardware consists of the following:

- Analyzer
- Precision components required for calibration and performance verification

The ShockLine MS46122A Series VNA internal system modules perform the following functions:

Source Module

This module provides the stimulus to the device under test (DUT). The frequency range of the source and test set modules establish the frequency range of the system.

Test Set Module

The test set module routes the stimulus signal to the DUT and samples the reflected and transmitted signals. The type of connector used is important, as is the “Auto Reversing” feature. Auto Reversing means that it applies the stimulus signal in both the forward and reverse direction. The direction is reversed automatically. This saves you from having to reverse the test device physically to measure all four scattering parameters (S-parameters). Frequency conversion occurs in the test set module.

Analyzer Module

The analyzer module receives, and interprets the 3rd IF signal for phase and magnitude data. It then displays the results of this analysis on the ShockLine Software display. This display can show all four S-parameters simultaneously.

A-4 Network Analyzers

We will begin this discussion with a subject familiar to most Anritsu customers: scalar network analysis. After showing comparisons, we will proceed to the fundamentals of network analyzer terminology and techniques. This discussion serves as an introduction to topics presented in greater detail later in this section. This discussion will touch on new concepts that include the following:

- Reference Delay
- S-parameters: what they are and how they are displayed
- Complex Impedance and Smith Charts

Scalar Analyzer Comparison

SCALAR NETWORK ANALYZERS

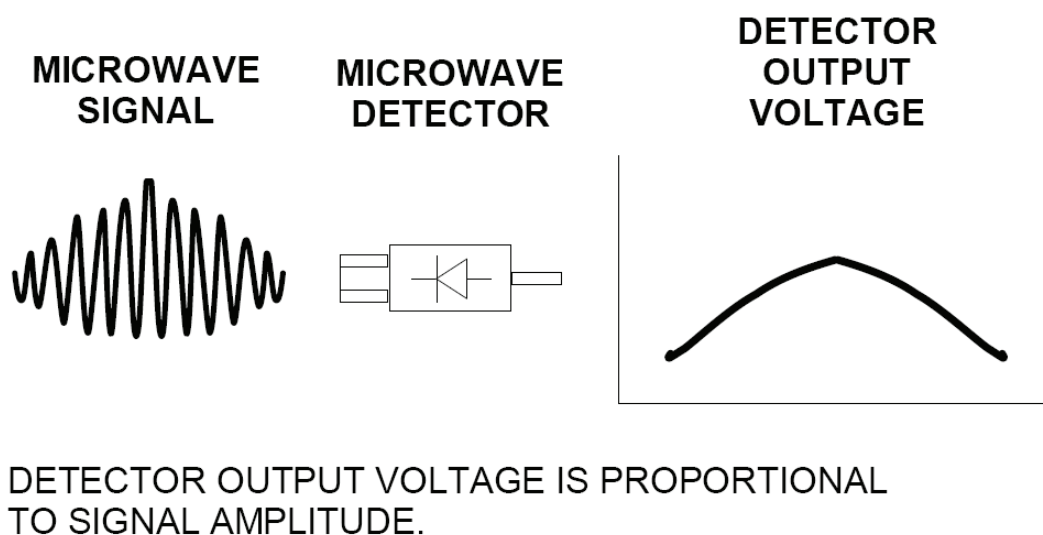

Figure A-3. Scalar Analyzer Detection

Network Analyzers do everything that scalar analyzers do except display absolute power, although absolute power can be displayed on a network analyzer through the use of a receiver calibration. In addition, they add the ability to measure the phase characteristics of microwave devices and allow greater dynamic range.

If all a Network Analyzer added was the capability for measuring phase characteristics, its usefulness would be limited. While phase measurements are important in themselves, it is the availability of this phase information that unlocks many new features for complex measurements. These features include Smith Charts, Time Domain, and Group Delay. Phase information also allows greater accuracy through *vector error correction* of the measured signal.

First, let us look at scalar network analyzers (SNAs). SNAs measure microwave signals by converting them to a DC voltage using a diode detector (Figure A-3). This DC voltage is proportional to the magnitude of the incoming signal. The detection process, however, ignores any information regarding the phase of the microwave signal.

In a vector network analyzer, access is needed to both the magnitude and phase of a microwave signal. There are several different ways to perform the measurement. The method Anritsu employs (called Harmonic Sampling or Harmonic Mixing) is to down-convert the signal to a lower intermediate frequency (IF). This signal can then be measured directly by a tuned receiver. The tuned receiver approach gives the system greater dynamic range. The system is also much less sensitive to interfering signals, including harmonics.

Vector Network Analyzer Basics

The vector network analyzer is a tuned receiver (Figure A-4). The microwave signal is down converted into the pass band of the IF. To measure the phase of this signal, we must have a reference to compare it with. If the phase of a signal is 90 degrees, it is 90 degrees different from the reference signal (Figure A-5). The network analyzer would read this as -90 degrees, since the test signal is delayed by 90 degrees with respect to the reference signal.

This phase reference can be obtained by splitting off some of the microwave signal before the measurement (Figure A-7).

A NETWORK ANALYZER IS A TUNED RECEIVER

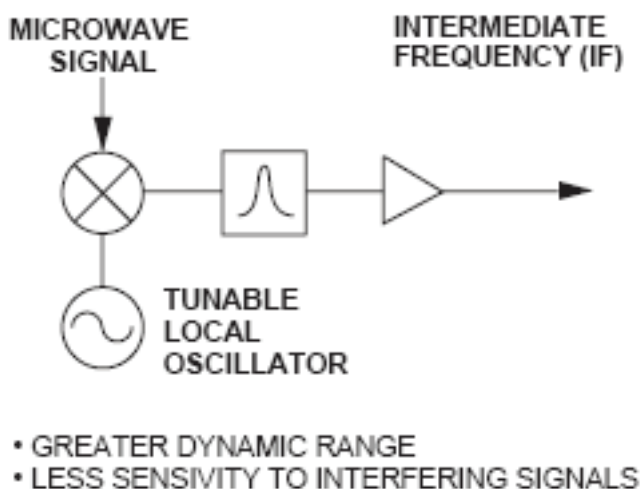

Figure A-4. Network Analyzer as a Tuned Receiver

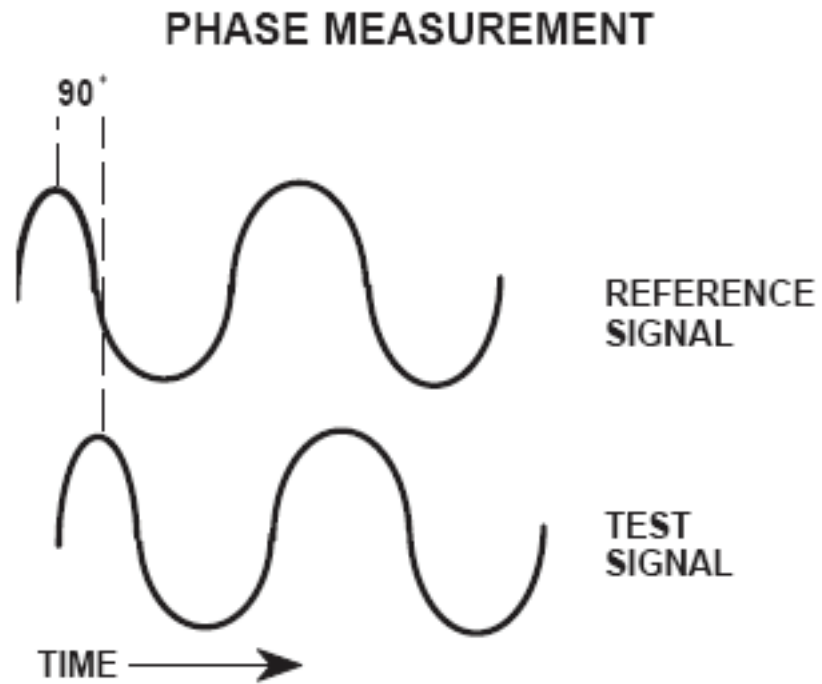

Figure A-5. Signals with a 90 Degree Phase Difference

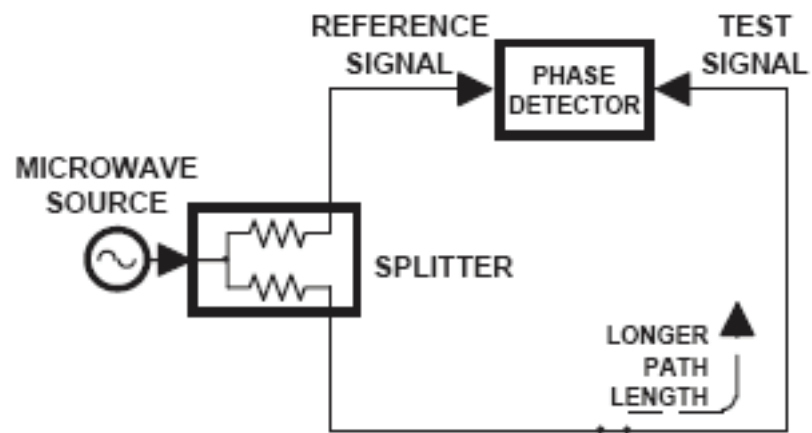

Figure A-6. Split Signal where a Length of Line Replaces the DUT

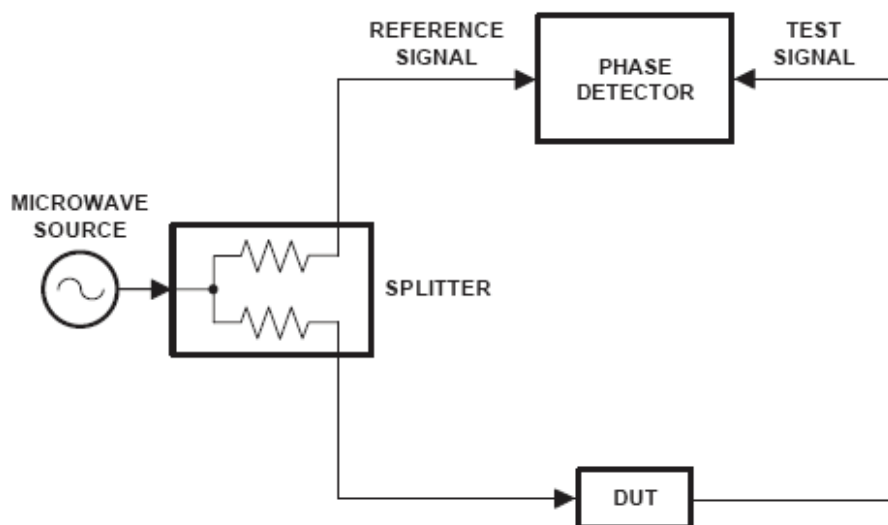

Figure A-7. Splitting the Microwave Signal

The phase of the microwave signal after it has passed through the device under test (DUT) is then compared with the reference signal. A network analyzer test set automatically samples the reference signal, so no external hardware is needed.

Let us consider for a moment that you remove the DUT and substitute a length of transmission line (Figure A-6). Note that the path length of the test signal is longer than that of the reference signal. Now let us see how this affects our measurement.

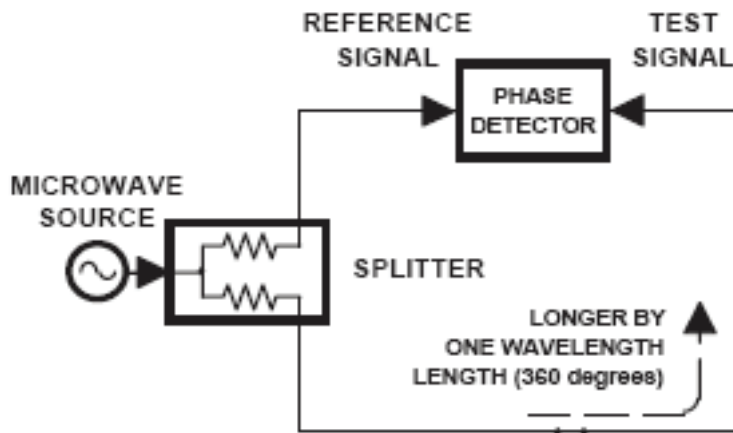

Figure A-8. Split Signal where Path Length is Different by Exactly One Wavelength

Assume that we are making a measurement at 1 GHz and that the difference in path-length between the two signals is exactly 1 wavelength. This means that test signal is lagging the reference signal by 360 degrees (Figure A-8). We cannot really tell the difference between one sine wave maxima and the next (they are all identical), so the network analyzer would measure a phase difference of 0 degrees.

Now consider that we make this same measurement at 1.1 GHz. The frequency is higher by 10 percent so therefore the wavelength is shorter by 10 percent. The test signal path length is now 0.1 wavelength longer than that of the reference signal (Figure A-9). This test signal is:

$$1.1 \times 360 = 396 \text{ degrees}$$

This is 36 degrees different from the phase measurement at 1 GHz. The network analyzer will display this phase difference as -36 degrees. The test signal at 1.1 GHz is delayed by 36 degrees more than the test signal at 1 GHz.

You can see that if the measurement frequency is 1.2 GHz, we will get a reading of -72 degrees, -108 degrees for 1.3 GHz, etc. (Figure A-10). There is an electrical delay between the reference and test signals. For this delay we will use the common industry term of reference delay.

You also may hear it called phase delay. In older network analyzers you had to equalize the length of the reference arm with that of the test arm to make an appropriate measurement of phase vs. frequency.

To measure phase on a DUT, we want to remove this phase-change-vs.-frequency due to changes in the electrical length. This will allow us to view the actual phase characteristics. These characteristics may be much smaller than the phase change due to electrical length difference.

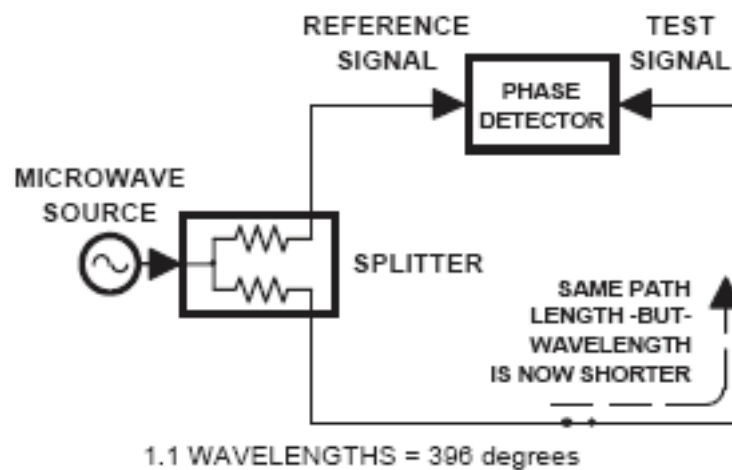

Figure A-9. Split Signal where Path Length is Longer than One Wavelength

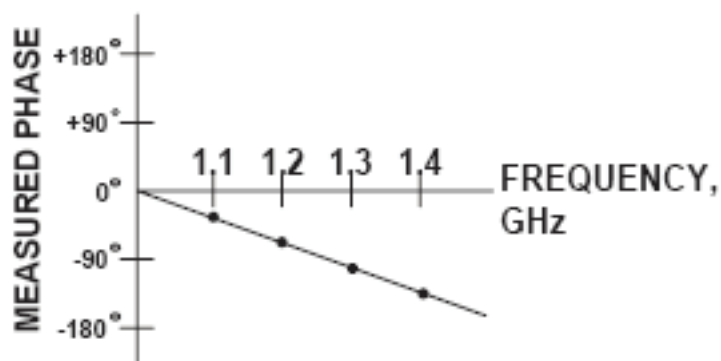

Figure A-10. Electrical Delay

There are two ways of accomplishing this. The most obvious way is to insert a length of line into the reference signal path to make both paths of equal length (Figure A-11). With perfect transmission lines and a perfect splitter, we would then measure a constant phase as we change the frequency. The problem using this approach is that we must change the line length with each measurement setup.

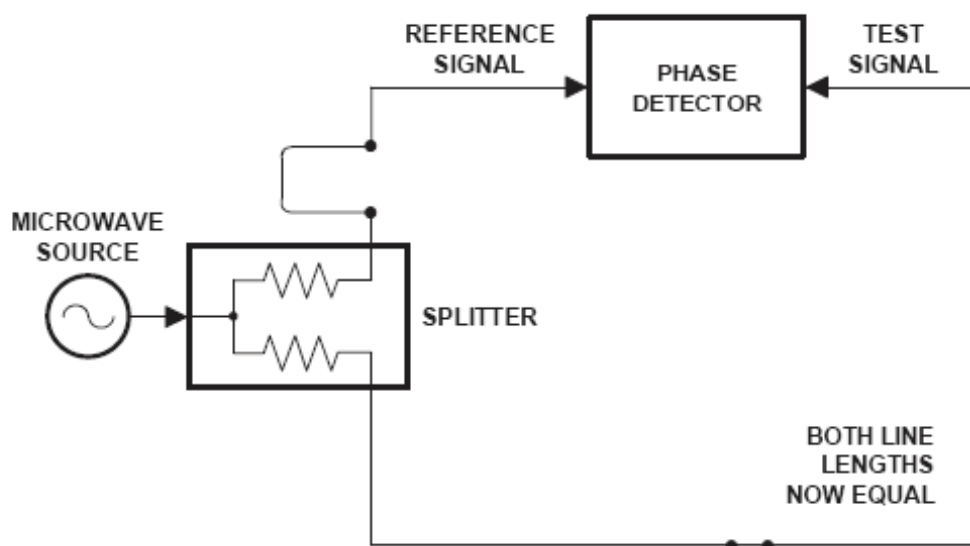

Figure A-11. Split Signal where Paths are of Equal Length

Another approach is to handle the path length difference in software. [Figure A-12](#) displays the phase-vs.-frequency of a device. This device has different effects on the output phase at different frequencies. Because of these differences, we do not have a perfectly linear phase response. We can easily detect this phase deviation by compensating for the linear phase. The size of the phase difference increases linearly with frequency so we can modify the phase display to eliminate this delay.

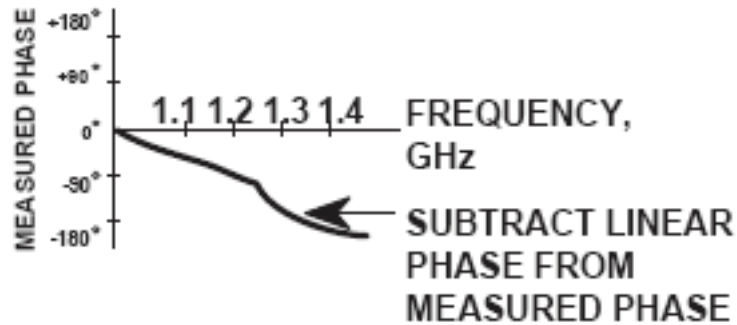

Figure A-12. Phase Difference Increases Linearly with Frequency

The ShockLine MS46122A Series VNA offers automatic reference delay compensation. [Figure A-13](#) shows the resultant measurement when we compensate path length. In a system application you can usually correct for length differences; however, the residual phase characteristics are critical.

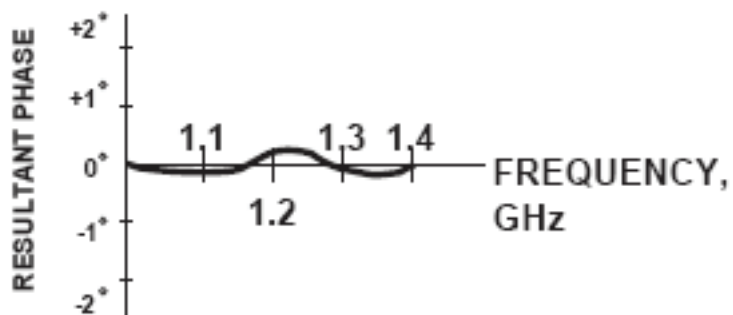

Figure A-13. Resultant Phase with Path Length

Now let us consider measuring the DUT. Consider a two port device; that is, a device with a connector on each end. What measurements would be of interest?

First, we could measure the reflection characteristics at either end with the other end terminated into 50-ohms. If we designate one end as the normal place for the input that gives a reference, we can then define the reflection characteristics from the reference end as forward reflection, and those from the other end as reverse reflection (Figure A-14).

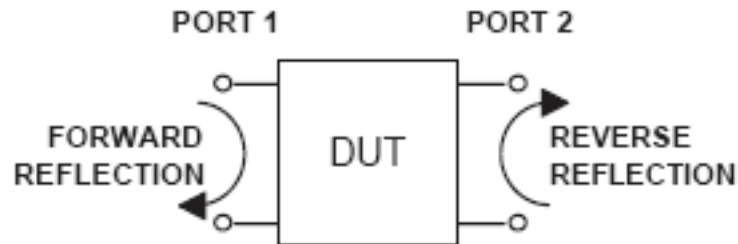

Figure A-14. Forward and Reverse Measurements

Second, we can measure the forward and reverse transmission characteristics. However, instead of saying “forward,” “reverse,” “reflection,” and “transmission” all the time, we use a shorthand. That is all that S-parameters are, a shorthand! The “S” stands for scattering. The second number is the device port that the signal is being injected into, while the first is the device port that the signal is leaving. S11, therefore, is the signal being injected into port 1 relative to the signal leaving port 1. The four scattering parameters (Figure A-15) are:

- S11: Forward Reflection
- S21: Forward Transmission
- S22: Reverse Reflection
- S12: Reverse Transmission

S-parameters can be displayed in many ways. An S-parameter consists of a magnitude and a phase. We can display the magnitude in dB, just like a scalar network analyzer. We often call this term log magnitude. We can display phase as “linear phase” (Figure A-16). As discussed earlier, we cannot tell the difference between one cycle and the next. Therefore, after going through 360 degrees, we are back to where we began. We can display the measurement from -180 to $+180$ degrees. The -180 to $+180$ degree approach is more common. It keeps the display discontinuity removed from the important 0 degree area used as the phase reference.

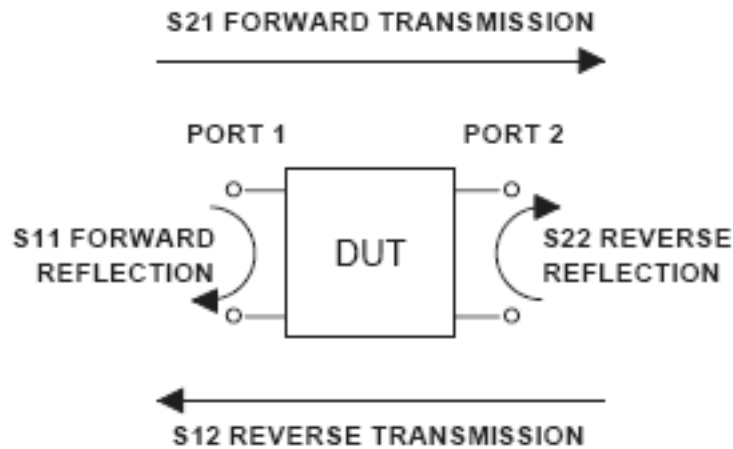

Figure A-15. S-Parameters



Figure A-16. Linear Phase with Frequency Waveform

There are several ways in which all the information can be displayed on one trace.

A-5 Polar Display

One method is a polar display (Figure A-17). The radial parameter (distance from the center) is magnitude. The rotation around the circle is phase. We sometimes use polar displays to view transmission measurements, especially on cascaded devices (devices in series). The transmission result is the addition of the phase and log magnitude (dB) information of each device's polar display.

Resistive and Reactive Terms

As we have discussed, the signal reflected from a DUT has both magnitude and phase. This is because the impedance of the device has both a resistive and a reactive term of the form $r+jx$. We refer to the r as the real or resistive term, while we call x the imaginary or reactive term. The j , which we sometimes denote as i , is an imaginary number.

It is the square root of -1 . If x is positive, the impedance is inductive; if x is negative, the impedance is capacitive.

The size and polarity of the reactive component x is important in impedance matching. The best match to a complex impedance is the complex conjugate. This complex-sounding term simply means an impedance with the same value of r and x , but with x of opposite polarity.

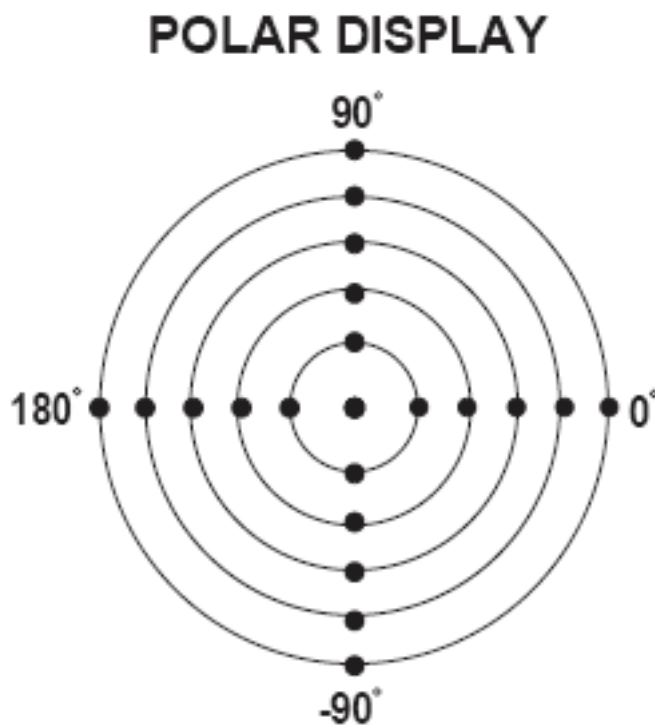

Figure A-17. Polar Display

A-6 Smith Chart

The complex conjugate is best analyzed using a Smith Chart (Figure A-18), which is a plot of r and x . To display all the information on a single S-parameter requires one or two traces, depending upon the format we want. A very common requirement is to view forward reflection on a Smith Chart (one trace) while observing forward transmission in Log Magnitude and Phase (two traces). Let us see how to accomplish this in the ShockLine.

MS46122A Series VNA.

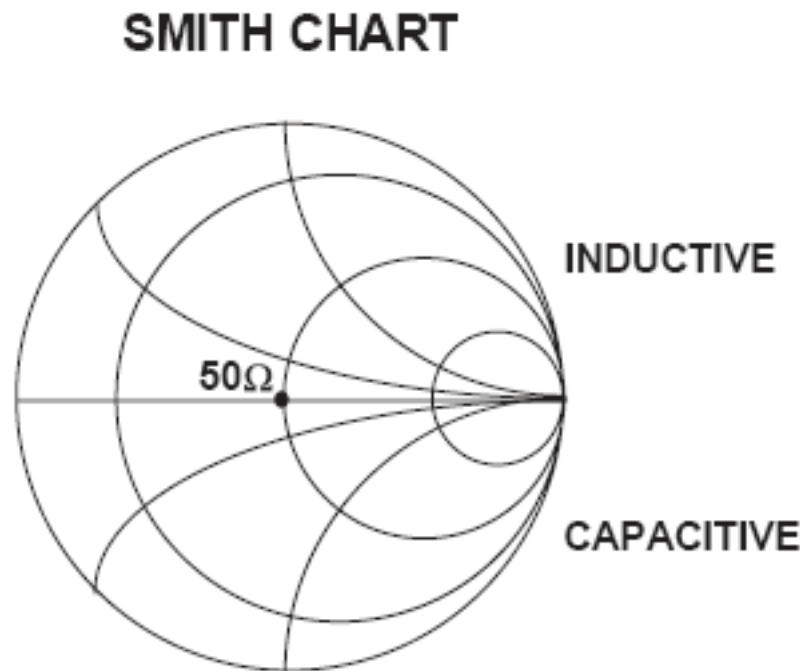

Figure A-18. Smith Chart

An important parameter we can measure when phase information is available is group delay. In linear devices, the phase change through the DUT is linear-with-frequency. Thus, doubling the frequency also doubles the phase change. An important measurement, especially for communications system users, is the rate of change-of-phase-vs.-frequency (group delay). If the rate of phase-change-vs.-frequency is not constant, the DUT is nonlinear. This nonlinearity can create distortion in communications systems.

Measurement Error Correction

Since we can measure microwave signals in both magnitude and phase, it is possible to correct for six major error terms:

- Source Test Port Match
- Load Test Port Match
- Directivity
- Isolation
- Transmission Frequency Response
- Reflection Frequency Response

We can correct for each of these six error terms in both the forward and reverse directions, hence the name 12-term error correction. Since 12-term error correction requires both forward and reverse measurement information, the test set must be *reversing*. “Reversing” means that it must be able to apply the measurement signal in either the forward or reverse direction.

MAGNITUDE AND PHASE OF EACH ERROR SIGNAL IS MEASURED



THEN THE RESULTANT VECTOR IS
APPLIED MATHEMATICALLY, HENCE
VECTOR ERROR CORRECTION

Figure A-19. Magnitude and Phase

To accomplish this error correction, we measure the magnitude and phase of each error signal (Figure A-19). Magnitude and phase information appear as a vector that is mathematically applied to the measurement signal. This process is termed *vector error correction*.

Appendix B — Maintenance and Security

B-1 Rack Ear Installation

The rack ear hardware is shipped with the unit and can be installed whenever required by the user. The general procedure to install the rack ear kit is described below.

1. Disconnect the power supply and any other attachments from the instrument.
2. Carefully place the instrument on a secure and stable work surface.
3. Refer to [Figure B-1](#). Using a type #1 Phillips screwdriver, remove the screws from the four feet (#1) on the bottom of the unit.
4. Pull off the front and rear shroud (#2) exposing the mounting strips.
5. Remove the four mounting strips (#3) from the top and bottom of the unit.
6. Remove the two flat head screws on the sides of the top cover.

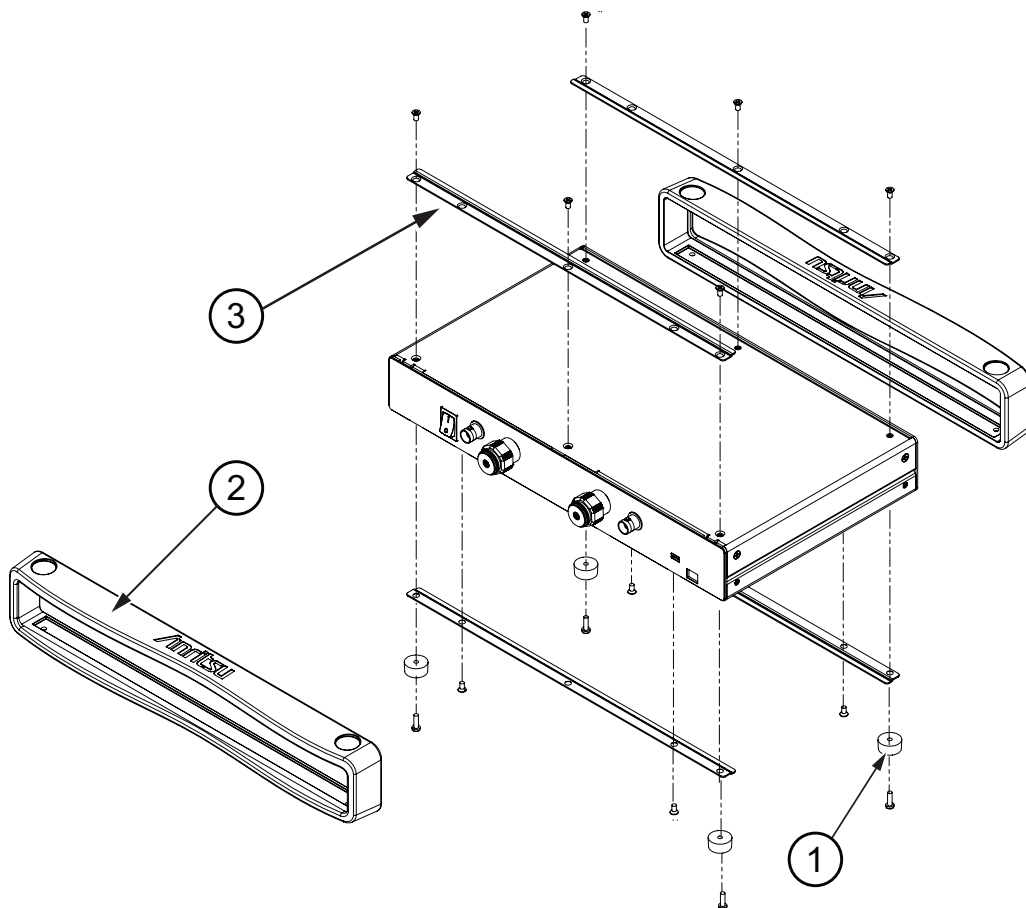

1. Bottom Feet (one of four)

2. Mounting Strips (one of four)

3. Shrouds (one of two)

Figure B-1. Rack Ear Preparation

Note The rack ear kit (3-80790) is shipped with the MS46122A.

7. Refer to [Figure B-2](#). Install the rack ears in the orientation as shown using the four flat heads screws provided.
8. Re-install the three flat head screws into the top panel.
9. Install the four pan head M3 x 6 mm screws supplied with the rack ear bracket to the side panel.

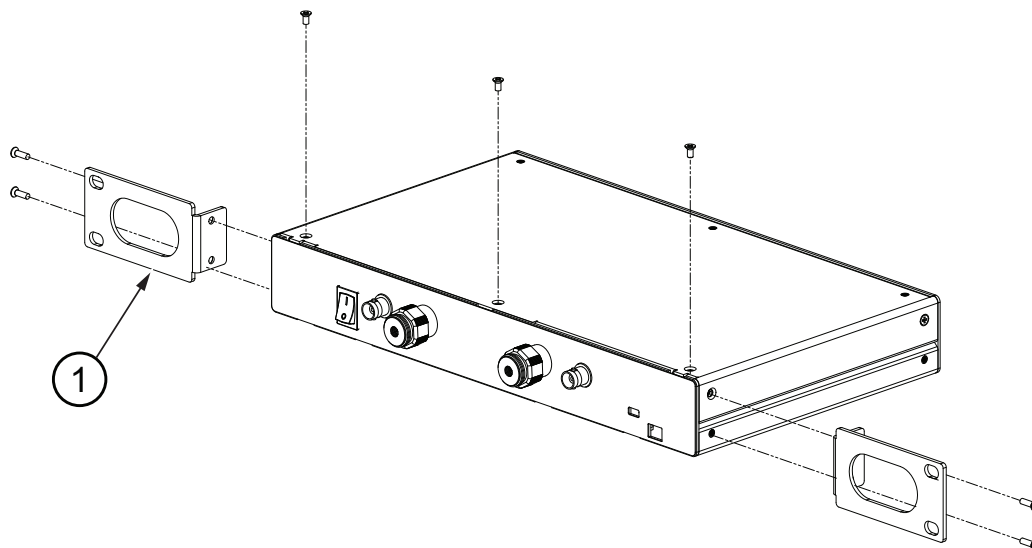

1. Rack Ears (one of two)

Figure B-2. Rack Ear Installation

B-2 Security and Memory Overview

The ShockLine MS46122A Series VNA does not require memory purging after it has been removed from a secure location, since there is no data memory in the unit.

B-3 Preparation for Storage or Shipment

Use the following information for preparing the ShockLine MS46122A Series VNA for storage or shipment.

Preparation for Storage

Preparing the VNA for storage consists of cleaning the unit, packing it inside of the storage container with moisture-absorbing desiccant crystals, and storing the unit in a temperature-controlled environment that is maintained between $-40\text{ }^{\circ}\text{C}$ and $+75\text{ }^{\circ}\text{C}$.

Preparation for Shipment

To provide maximum protection against damage in transit, the VNA should be repackaged in the original shipping container. If this container is not available and the unit is being returned to Anritsu for repair, advise Anritsu Customer Service to inquire about obtaining a suitable container. In the event these options are not possible, instructions for packaging and shipment are given below:

Remove Attached Equipment and Connectors

1. Remove any user-supplied connectors or adapters. If installed, remove the rack mounting ears and related hardware.

Use a Suitable Container

2. Obtain a corrugated cardboard carton with at least 125 kg test strength. This carton should have inside dimensions of no less than 15 cm (6.0") larger than the instrument unit dimensions to allow for cushioning.

Dimensions

3. The instrument body dimensions are:
 - **Height:** 61 mm
 - **Width:** 328 mm
 - **Depth:** 198 mm

Protect the Instrument

4. Surround the unit with polyethylene sheeting to protect the finish. A sealed bag is recommended as a best practice.

Cushion the Instrument

5. Cushion the instrument on all sides by tightly packing dunnage or urethane foam between the carton and the unit. Provide at least 8 cm (3.0") of dunnage on all sides; best practices recommend completely filling the space between the carton and instrument with dunnage.

Seal the Container

6. Seal the carton by using either shipping tape or an industrial stapler.

Address the Container

7. If the instrument is being returned to Anritsu for service, mark the address of the appropriate Anritsu service center and your return address on the carton in one or more prominent locations.

Contact information for all worldwide Anritsu Service Centers is available on the web site at:

<http://www.anritsu.com/Contact.asp>

Appendix C — Abbreviation Glossary

C-1 Appendix Overview

This glossary defines the abbreviations and terms that appear on the connectors and buttons of the MS46122A Series VNA. In some cases, due to space limitations, multiple abbreviations are used for the same term or the same abbreviation is used with different punctuation.

C-2 Glossary

Abbreviation or Term	Meaning / Definition (1 of 14)
%	Percentage
#	Number
(1:2):3	One differential pair and one singleton. Trace and dialog labeling for Mixed-mode with one differential pair and one singleton. In this example, The DUT port differential is measured from 1 to 2 and 3 is the singleton.
(1:2):3:4	One differential pair and two singletons. Trace and dialog labeling for Mixed-mode with one differential pair and two singletons. In this example, the DUT port differential is measured from 1 to 2 while 3 and 4 are the singletons.
(4:1):(2:3)	Two differential pairs. Trace and dialog labeling for Mixed-mode with two differential pairs. In this example, the first port pair is measured from 4 to 1 and the second port pair is measured from 2 to 3.
(4:2):1	One differential pair and one singletons. Trace and dialog labeling for Mixed-mode with one differential pair and one singleton. The DUT port differential is measured from 4 to 2 and 1 is the singleton.
(4:2):1:3	One differential pair and two singletons. Trace and dialog labeling for Mixed-mode with one differential pair and two singletons. In this example, the DUT port differential is measured from 4 to 2 while 1 and 3 are the singletons.
(1:2):(3:4)	Two differential pairs. Trace and dialog labeling for Mixed-mode with two differential pairs. In this example, the first port pair is measured from 1 to 2 and the second port pair is measured from 3 to 4.
1P2PF	Abbreviation for one-path two-port calibration forward direction. Used in the SCPI command:SENSe{1-16}:CORREction:COLLect[:METHod]:1P2PF to simulate the calibration.
1P2PR	Abbreviation for one path two port calibration reverse direction. Used in the SCPI command:SENSe{1-16}:CORREction:COLLect[:METHod]:1P2PR to simulate the calibration.
A1 a1	Reference 1 or Reference a
A2 a2	Reference 2 or Reference b
Actv.	Active
Addr.	Address
ALC	Automatic Level Control

Abbreviation or Term	Meaning / Definition (2 of 14)
ALRM A-LRM™	Calibration menu. Advanced-Line-Reflect-Match calibration algorithm and method. A-LRM is a trademark of Anritsu Company.
Auto-Return Auto-return	User interface. After a button selection, the instrument automatically returns to previous menu where the user selection is usually displayed on a field button. Auto-return buttons are usually a member of a button selection group (“a radio button” group) described below.
Avg.	Average
B1 b1	S-Parameter. Test 1 or Test a
B2 b2	S-Parameter. Test 2 or Test b
Bal.	Balance
BB	Broadband
BeginningSwp	Beginning sweep
Button Selection Group	Popular name is “radio button” group. A group of two or more soft buttons where selection of one button de-selects all other button members of the group. Often combined with auto-return function (described above) where the interface automatically returns to previous menu after the button selection is made.
Button Buttons	Individual elements of the right-side user interface menus. Button come in a variety of types such as toggle buttons, or menu buttons. See also “Soft buttons.” Compare with “hard keys.”
C(P) C(S) C(S)-L(P) C(P)-L(S)	Abbreviation for LC circuit primitives. Capacitance (Parallel), Capacitance (S), Capacitance (Series)-Inductor (Parallel), and Capacitance (Parallel)-Inductor (Series).
CAL (.CAL) File	File type extension.
Cal. Eff. Pwr	Calculated effective power
Cal Cal.	Calibrate Calibration
Cals Cals.	Calibrations
CCKTFour	A four-node capacitance C circuit. Port assignments are defined in separate commands. Available if the instrument is in 4-Port VNA mode.
Charac.	Characterize Characterization
cm	Distance units abbreviation. Centimeter.
Cnt	Count
Coax	Coaxial cable
Coef.	Coefficient
Comm.	Communication
Compress	Compression
Config.	Configure Configuration

Abbreviation or Term	Meaning / Definition (3 of 14)
CPLS	Parallel capacitance with series inductance. Available if the instrument is in 2-Port VNA mode.
CSLP	Series capacitance with parallel inductance. For capacitance only, set L to zero. Available if the instrument is in 2-Port VNA mode.
CW	Continuous Wave
D1S0	D One S Zero. In 4-Port VNAs, one differential pair and no singletons. Used in the MXP SETUP dialog box and the :CALCulate{1-16}:MXP SCPI commands. <ul style="list-style-type: none"> MAIN System SYSTEM Setup SETUP Misc. Setup MISC. SETUP MnP Files Setup MXP SETUP Dialog Box
D1S1	D One S One. In 4-Port VNAs, one differential pair and one singleton. Used in the MXP SETUP dialog box and the :CALCulate{1-16}:MXP SCPI commands. <ul style="list-style-type: none"> MAIN System SYSTEM Setup SETUP Misc. Setup MISC. SETUP MnP Files Setup MXP SETUP Dialog Box
D1S2	D One S Two. In 4-Port VNAs, one differential pair and two singletons. Used in the MXP SETUP dialog box and the :CALCulate{1-16}:MXP SCPI commands. <ul style="list-style-type: none"> MAIN System SYSTEM Setup SETUP Misc. Setup MISC. SETUP MnP Files Setup MXP SETUP Dialog Box
D2S0	D Two S Zero. In 4-Port VNAs, two differential pairs and no singletons. Used in the MXP SETUP dialog box and the :CALCulate{1-16}:MXP SCPI commands. <ul style="list-style-type: none"> MAIN System SYSTEM Setup SETUP Misc. Setup MISC. SETUP MnP Files Setup MXP SETUP Dialog Box
DAC	Digital to Analog Converter
Data/Mem	Data value divided by the memory value.
Data+Mem	Data value plus the memory value.
DataMem	Data value times the memory value.
Data-Mem	Data value minus the memory value.
DataMemMath	Data and memory mathematical equations.
dB	Decibels
dB/Div	SCALE menu toolbar function. Decibels per trace display division.
DDS	Direct Digital Synthesis
De-embed De-Embed Deembed	De-embedding. Process where calibration parameters for a test fixture are removed from the calibrated instrument and connection cables.
Deg Degs	Degree Degrees
Degs/Div	SCALE menu toolbar function. Degrees per trace display division. For circular Polar or Smith Chart displays only.
Diff.	Differential
Div.	Division
DTF	Distance to fault
DUT	Device under test

Abbreviation or Term	Meaning / Definition (4 of 14)
E/DE EDE Embed Embedding	Embedding/De-Embedding. Process where known calibration parameters for a test fixture are added to the instrument calibration consisting of just the instrument and connection cables.
EMC	Electromagnetic Compatibility
Eqn	Equation
Ext.	External
Ext. Src. Addr.	External source address
Extrap	Extrapolation
Fctry	Factory
Field Toolbar	When some buttons are selected, the field toolbar that appears near the top of the screen display just below the icon toolbar. The toolbar provides user control to select the value of the required input such as a frequency, attenuation level, or device address. Some toolbar fields allow the selection of units; for example, frequency field toolbars allow selection of Hz, kHz, MHz, or GHz units. Some field toolbars appear at the bottom of the display area when editing table information such as for Segmented Sweep operations.
Flash drive	See USB Memory Device.
Freq-Base	Frequency-Based
Freq Freq.	Frequency
FreqIniTable.ini	File type.
FreqTable.mft	File type.
Full 2-port Full Two port	Calibration method. Also called “12 Term Calibration.”
FULL1	Abbreviation for full one port calibration. Used in the SCPI command :SENSe{1-16}:CORRection:COLLect[:METHod]:FULL1 to simulate the calibration.
FULL2	Abbreviation for full two port calibration. Used in the SCPI command :SENSe{1-16}:CORRection:COLLect[:METHod]:FULL2 to simulate the calibration.
FULLB	Abbreviation for full one port reflection calibration both ports. Used in the SCPI command :SENSe{1-16}:CORRection:COLLect[:METHod]:FULLB to simulate the calibration.
GHz	Gigahertz. 10E9 Hertz.
GPIB	IEEE-488.2 General Purpose Interface Bus. GPIB Command.
GUI	Graphical User Interface
HDD	Hard Disk Drive
Het.	Heterodyne
ID	Identification number
IEC	International Electrotechnical Commission
IEEE	Institute of Electrical and Electronics Engineers
IEEE-488.2	IEEE Specification 488.2 for General Purpose Interface Bus (GPIB)

Abbreviation or Term	Meaning / Definition (5 of 14)
IF	Intermediate Frequency
IFBW	Intermediate Frequency Bandwidth
Imag.	Imaginary
IMD	Intermodulation distortion
Imped.	Impedance
Imped. Transf.	Impedance transformation
Indep.	Independent
Inter.	Interface Interference
IntraTrace	Mathematical operations within the same trace display. As opposed to inter-trace operations.
IP	Internet Protocol
j	Imaginary number
jX	Reactance term in Ohms
K Connector	Connector type. Compatible with SMA, WSM and 3.5 mm connectors, it has a rated frequency range from DC to 40 GHz. K Connector is a trademark of Anritsu Company.
kHz	Kilohertz. 10E3 Hertz.
km	Distance units abbreviation. Kilometer.
L(P) L(S) L(P)-C(S) L(S)-C(P)	Abbreviation for LC circuit primitives. Inductor (Parallel), Inductor (Series), Inductor (Series)-Capacitance (Parallel), and Inductor (Parallel) and Capacitance (Series).
Lang.	Language
LCD	Liquid Crystal Display
LCKTFour	A four-node inductance L circuit. Port assignments are defined in separate commands. Available if the instrument is in 4-Port VNA mode.
Lft	Left
Lin	Linear
LO	Local Oscillator
Log	Logarithmic
LogMag	Logarithmic Magnitude
LRL/LRM	Calibration method. Line-reflect-line calibration algorithm. Line-reflect-match calibration algorithm.
LSCP	Series inductance with parallel capacitance. For inductance only, set C to zero. Available if the instrument is in 2-Port VNA mode.
LSCS	Parallel inductance with series capacitance. Available if the instrument is in 2-Port VNA mode.
LVD	Low Voltage Directive
m	Distance unit abbreviation. Meter.
Mag Mag.	Magnitude
max Num	Maximum Number

Abbreviation or Term	Meaning / Definition (6 of 14)
Max max	Maximum
MB/s	Megabytes per second
Mb Mbit	Megabit. 1 megabit equals 10E6 bits or 1,000,000 bits.
MB Mbyte	Megabyte. In SI decimal units, 1 megabyte equals 1000E3 bytes or 1,000,000 bytes. In IEC binary units, a “mebibyte or MiB” equals 1024E3 bytes or 1,048,576 bytes, but is also commonly called a “megabyte.”
Mem Mem.	Memory
Memory stick	See USB Memory Device.
menu	Available menus in the top level menu-bar command interface.
Menu command	Individual commands listed on a drop-down menu from the top menu bar. For example, on the File menu, the first command is Recall.
MFT (.mft) Files	File type extension.
MG	Anritsu Measurement Guide
MHz	Megahertz. 10E6 Hertz. 1,000,000 Hertz
Micr.	Microporous Teflon dielectric type
Min Min.	Minimum
Misc.	Miscellaneous
Mkr # [OFF]	Marker number with the Reference Marker function toggled off and the marker also toggled off; for example, Mkr 1 [OFF] for Marker 1.
Mkr # [ON]	Marker number with the Reference Marker function toggled off and the marker toggled on; for example, Mkr 1 [ON] for Marker 1.
Mkr#-Ref [OFF]	Marker number with the Reference Marker function toggled on and the marker toggled off; for example, Mkr1-Ref [OFF] for Marker 1.
Mkr#-Ref [ON]	Marker number with the Reference Marker function toggled on and the marker also toggled on; for example, Mkr1-Ref [ON] for Marker 1.
Mkr Mkrs	Marker, Markers
mm	Units abbreviation. Millimeter.
MM	Anritsu Maintenance Manual
mmWave mm-Wave	Millimeter wavelength
Model#	Model Number
ms	Time units abbreviation. Millisecond.
MS46122A Series VNA	The function or feature refers to any VNA model in the series: MS46122A.

Abbreviation or Term	Meaning / Definition (7 of 14)
Navigation paths	<p>Navigation to a menu or dialog box of interest is entered using navigation notation where the pipe (“ ”) symbol is used to separate elements. The starting menu is usually the MAIN Menu. The general format is with menu and dialog boxes in ALL CAPS and buttons in Title Case; both use this distinctive Sans Serif Font in the general format: MAIN Button MENU ... Button DESTINATION MENU/DIALOG BOX</p> <p>For example, the navigation path to the REFERENCE PLANE menu is: MAIN Measurement MEASUREMENT Reference Plane REFERENCE PLANE</p>
NIST	National Institute of Standards and Technology.
ns	Time units abbreviation. Nanosecond.
Ntwk Ntwk.	Network
Ohms/Div	SCALE menu toolbar function. Ohms (Ω) per trace display division.
OM	Anritsu Operations Manual
Op.	Operand Operation Operations
Out.	Output
P2P	Pulse-to-Pulse
Param.	Parameter Parameters
PDF	Proprietary Portable Document Format from Adobe Corporation.
PG	Pulse Generator
PIP	Point-in-Pulse
PM	Anritsu Programming Manual
Prev Prev.	Previous
PRF	Pulse Repetition Frequency
PRI	Pulse Repetition Interval
Profile	Pulse Profile
ps	Time units abbreviation. Picosecond.
Pwr Pwr.	Power
R	Resistance
R(P), R(S)	Parallel Resistance, Series Resistance
R-Circuit	Resistive element of an L-C circuit
RCKTFour	A four-node resistive R circuit. Port assignments are defined in separate commands. Available if the instrument is in 4-Port VNA mode.
Rcvr Rcvr.	Receiver

Abbreviation or Term	Meaning / Definition (8 of 14)
Rect.	Reactance Rectangle Rectangular
Ref.Mkr	Reference Marker
Ref Ref.	Reference
RESP1	Abbreviation for one-port response calibration. Used in the SCPI command :SENSe{1-16}:CORRection:COLLect[:METHod]:RESP1 to simulate the calibration.
RESPB	Abbreviation for one-port response calibration both ports. Used in the SCPI command :SENSe{1-16}:CORRection:COLLect[:METHod]:RESPB to simulate the calibration.
RF	Radio Frequency
RP	Resistive parallel network. Available if the instrument is in 2-Port VNA mode.
RS	Resistive series network. Available if the instrument is in 2-Port VNA mode.
Rt	Right
s	Time units abbreviation. Second.
S11	S-Parameter. Used in text for S-parameter measurement of input reflection coefficient. In text written as "S11". Mathematical version uses subscripts as S_{11} . Available in 2-Port and 4-Port VNAs.
S12	S-Parameter. Used in text for S-parameter measurement of reverse transmission coefficient. Mathematical version uses subscripts as S_{12} . Available in 2-Port and 4-Port VNAs.
S13	S-Parameter. Used in test for S-parameter measurement. Mathematical version used subscripts as S_{13} . Available only in 4-Port VNAs.
S14	S-Parameter. Used in test for S-parameter measurement. Mathematical version used subscripts as S_{14} . Available only in 4-Port VNAs.
S21	S-Parameter. Used in text for S-parameter measurement of forward transmission coefficient. Mathematical version uses subscripts as S_{21} . Available in 2-Port and 4-Port VNAs.
S22	S-Parameter. Used in text for S-parameter measurement of output reflection coefficient. Mathematical version uses subscripts as S_{22} . Available in 2-Port and 4-Port VNAs.
S23	S-Parameter. Used in test for S-parameter measurement. Mathematical version used subscripts as S_{23} . Available only in 4-Port VNAs.
S24	S-Parameter. Used in test for S-parameter measurement. Mathematical version used subscripts as S_{23} . Available only in 4-Port VNAs.

Abbreviation or Term	Meaning / Definition (9 of 14)
s2p	File extension. Abbreviation for S-parameter 2-Port configuration file. The general type of file extension is referred to as “.snp” file where the “n” refers to the number of ports, such as “.s1p” for an S-parameter 1-Port configuration file.
S2Pfile	Allows an S2P calibration file to be used. Available if the instrument is in 2-Port VNA mode.
S31	S-Parameter. Used in test for S-parameter measurement. Mathematical version used subscripts as S_{31} . Available only in 4-Port VNAs.
S32	S-Parameter. Used in test for S-parameter measurement. Mathematical version used subscripts as S_{32} . Available only in 4-Port VNAs.
S33	S-Parameter. Used in test for S-parameter measurement. Mathematical version used subscripts as S_{33} . Available only in 4-Port VNAs.
S34	S-Parameter. Used in test for S-parameter measurement. Mathematical version used subscripts as S_{34} . Available only in 4-Port VNAs.
S41	S-Parameter. Used in test for S-parameter measurement. Mathematical version used subscripts as S_{41} . Available only in 4-Port VNAs.
S42	S-Parameter. Used in test for S-parameter measurement. Mathematical version used subscripts as S_{42} . Available only in 4-Port VNAs.
S43	S-Parameter. Used in test for S-parameter measurement. Mathematical version used subscripts as S_{43} . Available only in 4-Port VNAs.
S44	S-Parameter. Used in test for S-parameter measurement. Mathematical version used subscripts as S_{44} . Available only in 4-Port VNAs.
S4Pfile	Allows an S4P calibration file to be used. Available if the instrument is in 4-Port VNA mode.
SC1C1	Two differential pairs. Trace labeling for Mixed-mode with two differential pairs. S-parameter for common-mode reception at Pair 1 and common-mode drive at Pair 1.
SC1C2	Two differential pairs. Trace labeling for Mixed-mode with two differential pairs. S-parameter for common-mode reception at Pair 1 and common-mode drive at Pair 2.
SC1D1	Two differential pairs. Trace labeling for Mixed-mode with two differential pairs. S-parameter for common-mode reception at Pair 1 and differential drive at Pair 1.
SC1D2	Two differential pairs. Trace labeling for Mixed-mode with two differential pairs. S-parameter for common-mode reception at Pair 1 and differential drive at Pair 2.
SC2C1	Two differential pairs. Trace labeling for Mixed-mode with two differential pairs. S-parameter for common-mode reception at Pair 2 and common-mode drive at Pair 1.

Abbreviation or Term	Meaning / Definition (10 of 14)
SC2C2	Two differential pairs. Trace labeling for Mixed-mode with two differential pairs. S-parameter for common-mode reception at Pair 2 and common-mode drive at Pair 2.
SC2D1	Two differential pairs. Trace labeling for Mixed-mode with two differential pairs. S-parameter for common-mode reception at Pair 2 and differential drive at Pair 1.
SC2D2	Two differential pairs. Trace labeling for Mixed-mode with two differential pairs. S-parameter for common-mode reception at Pair 2 and differential drive at Pair 2.
SCC	<p>One differential pair and one singleton. Trace labeling for Mixed-mode with common-mode reception at Pair 1 and common-mode drive at Pair 1. S-Parameter for common-mode reception at Pair 1 and common-mode drive at Pair 1.</p> <p>One differential pair and two singletons. Trace labeling for Mixed-mode for Pair 1 common-mode reception and Pair 1 drive. S-Parameter for common-mode reception at Pair 1 and common-mode drive at Pair 1.</p> <p>Trace labeling for Mixed-mode with common-mode reception at Pair 1 and common-mode drive at Pair 2. S-Parameter for common-mode reception at Pair 1 and common-mode drive at Pair 1.</p>
SCD	<p>One differential pair and one singleton. Trace labeling for Mixed-mode for Pair 1 reception and Pair 1 drive. S-Parameter for common-mode reception at Pair 1 and differential drive at Pair 1.</p> <p>One differential pair and two singletons. Trace labeling for Mixed-mode with common-mode reception at Pair 1 and differential drive at Pair 2. S-Parameter for common-mode reception at Pair 1 and differential drive at Pair 1.</p>
SCX	<p>One differential pair and one singleton. Trace labeling for Mixed-mode with Pair 1 common-mode reception and singleton drive. S-Parameter for common-mode reception at Pair 1 and singleton drive.</p> <p>One differential pair and two singletons. Trace labeling for Mixed-mode with common-mode reception at Pair 1 and drive at first singleton. S-Parameter for common-mode reception at Pair 1 and first singleton drive.</p>
SCY	One differential pair and two singletons. Trace labeling for Mixed-mode with common-mode at Pair 1 and drive at second singleton. S-Parameter for common-mode reception at Pair 1 and second singleton drive.
SD1C1	Two differential pairs. Trace labeling for Mixed-mode with two differential pairs. S-parameter for differential reception at Pair 1 and common-mode drive at Pair 2.
SD1C2	Two differential pairs. Trace labeling for Mixed-mode with two differential pairs. S-parameter for differential reception at Pair 1 and common-mode drive at Pair 2.
SD1D1	Two differential pairs. Trace labeling for Mixed-mode with two differential pairs. S-parameter for differential reception at Pair 1 and differential drive at Pair 2.

Abbreviation or Term	Meaning / Definition (11 of 14)
SD1D2	Two differential pairs. Trace labeling for Mixed-mode with two differential pairs. S-parameter for differential reception at Pair 1 and differential drive at Pair 2.
SD2C1	Two differential pairs. Trace labeling for Mixed-mode with two differential pairs. S-parameter for differential reception at Pair 2 and common-mode drive at Pair 1.
SD2C2	Two differential pairs. Trace labeling for Mixed-mode with two differential pairs. S-parameter for differential reception at Pair 2 and common-mode drive at Pair 2.
SD2D1	Two differential pairs. Trace labeling for Mixed-mode with two differential pairs. S-parameter for differential reception at Pair 2 and differential drive at Pair 1.
SD2D2	Two differential pairs. Trace labeling for Mixed-mode with two differential pairs. S-parameter for differential reception at Pair 2 and differential drive at Pair 2.
SDC	<p>One differential pair and one singleton. Trace labeling for Mixed-mode for Pair 1 reception and Pair 1 drive. S-Parameter for differential reception at Pair 1 and common-mode drive at the port pair.</p> <p>One differential pair and two singletons. Trace labeling for Mixed-mode with differential reception at Pair 1 and common-mode drive at Pair 1. S-Parameter for differential reception and common-mode drive at Pair 1.</p>
SDD	<p>One differential pair and one singleton. Trace labeling for Mixed-mode for Pair 1 reception and Pair 1 drive. S-Parameter for differential reception and differential drive.</p> <p>One differential pair and two singletons. Trace labeling for Mixed-mode with differential reception at Pair 1 and differential drive at Pair 1. S-Parameter for differential reception and differential drive at Pair 1.</p>
SDX	<p>One differential pair and one singleton. Trace labeling for Mixed-mode for Pair 1 reception and singleton drive. S-Parameter for differential reception at Pair 1 and singleton drive.</p> <p>One differential pair and two singletons. Trace labeling for Mixed-mode with differential reception at Pair 1 and drive at first singleton. S-Parameter for differential reception at Pair 1 and first singleton drive.</p>
SDY	One differential pair and two singletons. Trace labeling for Mixed-mode with differential reception at Pair 1 and drive at second singleton. S-Parameter for differential reception at Pair 1 and second singleton drive.
Seg.	Segment Segmented
SerNum	Serial Number
Set.	Settings
SI	International System of Units
Single Offset	Calibration method

Abbreviation or Term	Meaning / Definition (12 of 14)
Soft buttons	Buttons that appear in the right side menu interface on the MS46122A Series VNA screen. In text, the name of the menu is formatted with a distinctive font in capitals, such as the FREQUENCY menu. Soft buttons on each menu, such as the Select Port toggle button are formatted in the same font with initial capitals.
SOLT/SOLR	Calibration methods. Short-open-load-thru or short-open-load-reciprocal calibration algorithm.
Sparam	S-Parameters or scattering parameters
S-Parameters s-parameters	Scattering parameters.
Src Src.	Source
SRPRP SRR SXR SRX SXX	General button format for mixed mode settings. In 4-port VNA mixed mode settings, this is the name format of the selectable button names. For buttons with five letters, “S” indicates a mixed mode S-Parameter, “R” is the selected response type of either “D” for differential or “C” for common mode, and “P” is the Port number between 1 and 4. For buttons with three letters, “S” indicates a mixed-mode S-Parameter, “R” is the selected response type of either “D” for differential or “C” for common mode, and “X” is the singleton drive.
SSD	Solid State Drive
SSLT/SSLR	Calibration methods. Short-short-load-thru or short-short-load-reciprocal calibration algorithm
SSST/SSSR	Calibration methods. Short-short-short-thru or short-short-short-reciprocal calibration algorithm. Also called “Triple Offset Short”.
Swp	Sweep
SWR	Standing Wave Ratio
SXC	<p>One differential pair and one singleton. Trace labeling for Mixed-mode with first singleton reception and common-mode drive at Pair 1. S-Parameter for first singleton reception and common-mode drive at Pair 1.</p> <p>One differential pair and two singletons. Trace labeling for Mixed-mode with singleton reception and differential drive. S-Parameter for singleton reception and common-mode drive at Pair 1.</p>
SXD	<p>One differential pair and one singleton. Trace labeling for Mixed-mode with singleton reception and Pair 1 drive. S-Parameter for singleton reception and differential drive at Pair 1.</p> <p>One differential pair and two singletons. Trace labeling for Mixed-mode with first singleton reception and differential drive at Pair 1. S-Parameter for first singleton reception and differential drive at Pair 1.</p>
SXX	<p>One differential pair and one singleton. Trace labeling for Mixed-mode with singleton reception and singleton drive. S-Parameter for singleton reception and singleton drive.</p> <p>One differential pair and two singletons. Trace labeling for Mixed-mode with first singleton reception and first singleton drive. S-Parameter for first singleton reception and first singleton drive.</p>

Abbreviation or Term	Meaning / Definition (13 of 14)
SXY	One differential pair and two singletons. Trace labeling for Mixed-mode with first singleton reception and first singleton drive. S-Parameter for first singleton reception and second singleton drive.
SYC	One differential pair and two singletons. Trace labeling for Mixed-mode with second singleton reception and common-mode drive at Pair 1. S-Parameter for second singleton reception and common-mode drive at Pair 1.
SYD	One differential pair and two singletons. Trace labeling for Mixed-mode with second singleton reception and differential drive at Pair 1. S-Parameter for second singleton reception and differential drive at Pair 1.
SYX	One differential pair and two singletons. Trace labeling for Mixed-mode with second singleton reception and first singleton drive. S-Parameter for second singleton reception and first singleton drive.
SYY	One differential pair and two singletons. Trace labeling for Mixed-mode with second singleton reception and second singleton drive. S-Parameter for second singleton reception and second singleton drive.
TCP	Transmission Control Protocol. Part of the Ethernet network communication protocol.
TDS	Anritsu Technical Data Sheet. Document location of the most recent instrument performance specifications.
TFRB	Abbreviation for transmission frequency response calibration both directions. Used in the SCPI command :SENSe{1-16}:CORRection:COLLect[:METHod]:TFRB to simulate the calibration.
TFRF	Abbreviation for transmission frequency response calibration forward direction. Used in the SCPI command :SENSe{1-16}:CORRection:COLLect[:METHod]:TFRF to simulate the calibration.
TFRR	Abbreviation for transmission frequency response calibration reverse direction. Used in the SCPI command :SENSe{1-16}:CORRection:COLLect[:METHod]:TFRR to simulate the calibration.
TLine	A defined transmission line with specifications for Impedance (Ohms), Length (meters), Loss (dB/mm), @ Frequency (GHz), and Dielectric Value. Note that programmatically, length is entered in meters. From the user interface, length is usually entered in millimeters. Available if the instrument is in 2-Port VNA mode.
T-Line	Transmission line
TLINEFour	Allows two separate through (“thru”) lines to be used. In separate commands, each link is defined by Length (meters), @ Frequency (GHz), Z0-Odd (Ohms), Loss-Odd (dB/mm), Dielectric Odd (unitless number), Z0Even (Ohms), Loss-Even (dB/mm), and Dielectric Even (unitless number). Note that programmatically, length is entered in meters. From the user interface, length is usually entered in millimeters. Available if the instrument is in 4-Port VNA mode.
TMS	True Mode Stimulus
Toggle Button	A software button that toggles between two or more states such as ON and OFF or Port 1 and Port 2.

Abbreviation or Term	Meaning / Definition (14 of 14)
TR	Instrument mode. Transmission/reflection mode.
Transf Transf.	Transfer Transformation
Triple Offset Short	Calibration method. Short-short-short-thru. Commonly abbreviated as “SSST.”
TRL	Thru Reflect Line Calibration method. See LRL.
TRM	Thru Reflect Match Calibration method. See ALRM.
Tr Tr.	Trace
TS	Troubleshooting
TS Mode	Troubleshooting Mode
TTL	Transistor-Transistor Logic
U	Units
um	Distance units abbreviation. Micrometer.
Units/Div	SCALE menu toolbar function. Measurement units per trace display division.
us	Time units abbreviation. Microsecond.
USB	Universal Serial Bus
USB Memory Device	<p>Also called a “USB flash drive”, “USB stick”, “thumb drive”, or “memory stick.” In the context of Anritsu documentation, a USB memory device is used to transfer calibration, certification, and/or operating system updates to the MS46x20A instrument.</p> <p>When the instrument interface or hardware uses another term such as “Calibration Memory Device,” its first use is always followed by the “USB Memory Device” in parenthesis.</p> <p>For example: “...use the Calibration Memory Device (USB Memory Device) to load the characterization parameters for the calibration kit...”</p>
USB stick	See USB Memory Device.
UTF	Universal Test Fixture
V	Volts Voltage
V AC	Volts Alternating Current.
V Connector™	Anritsu Company trademarked connector name. Connector type. A 1.85 mm coaxial connector with a rated frequency range from DC to 65 GHz. V Connector is a trademark of Anritsu Company.
V DC	Volts Direct Current
VCO	Voltage Control Oscillator
VISA	Virtual Instrument System Architecture
VNA	Vector Network Analyzer
VSWR	Voltage Standing Wave Ratio

Subject Index

A

airflow 2-1
altitude, operating 2-1
APPLICATION Drop-Down Menu 4-13
Auto-Return Button Group 4-29

B

Back Button 4-26
Button Selection Icon 4-29

C

CALIBRATION Drop-Down Menu 4-13
Calibration Icon 4-17
Calibration Kits 1-2
Ch->Max Icon 4-17
Ch->Next Icon 4-17
Ch->Prev Icon 4-17
CHANNEL Drop-Down Menu 4-10
Channel Icon 4-17
Channel Status Bar Abbreviations 4-33
Channel Status Display 4-33
Completion Checkmark Button 4-30
Complex Impedance 4-34
Connecting External Devices 2-1
Connectors 3-1
Continue Icon 4-17
cooling, during operation 2-1

D

Dialog Boxes 4-31
Dimensions B-3
Display Areas 4-2
Display Icon 4-18

E

Environment 2-1
environment
 storage B-3
External Devices 2-5

F

FILE Drop-Down Menu 4-7
File Icon 4-18
Freq Icon 4-18
Front Panel 3-1

G

Group Delay 4-34, 4-37
Group Delay Graphs 4-43

H

HELP Drop-Down Menu 4-15
Help Icon 4-18
Hold Icon 4-18
Home Button 4-26
humidity, operating 2-1

I

Icon Toolbar 4-16
Icon Toolbar Functions 4-16
Imaginary 4-35
Impedance 4-35
Initial Inspection 2-1
Inspection 2-1
Installation 2-1
installation category 2-1
Instrument Status 4-32
Instrument Status Display Abbreviations 4-32

L

Limit Lines 4-45
Linear Mag 4-35
Linear Magnitude and Phase 4-36
Log Mag 4-35
Log Magnitude and Phase 4-35
Log Polar 4-36

M

MAIN Drop-Down Menu 4-9
Main Screen 4-1
Marker Icon 4-19
Marker-> Pk Rt Icon 4-19
Marker->Max Icon 4-18
Marker->Min Icon 4-18
Marker->Off 4-19
Marker->Peak Icon 4-19
Marker->Pk Lft Icon 4-19
MEASUREMENT Drop-Down Menu 4-13
Measurement Icon 4-19
Menu Bar 4-6
Menu Bar Drop-Down Menus 4-7
Menu Navigation Buttons 4-26
Models 1-1

N

Next Button 4-26

O

Operate Mode 2-3
Optional Icon Toolbar Functions 4-17
Options 1-1

P

Phase	4-35
Phase and Magnitude	4-34
phase, of power supply	2-1
Polar Graphs	4-42
Power Icon	4-19
Power Requirements	2-1
Power-On/Power-Off Procedure	2-2
Preparation for Use	2-1
Preset Icon	4-19
Previous	1-4
Print Icon	4-20

R

Real	4-35
Real and Imaginary	4-34, 4-36
Rear Panel	2-4, 3-1
Rear Panel Ports and Connectors	3-2
Rectilinear Paired Graphs	4-40
Rectilinear Single Graph	4-40
Reference Lines	4-44
Reference Position	4-44
Response Icon	4-20

S

Safety Symbols	
For Safety	Safety-2
In Manuals	Safety-1
On Equipment	Safety-1
Scale Icon	4-20
Shipment	B-3
shipping instrument	B-3
Smith (R + jX)	4-36
Smith Charts	4-41
Splash Screen	2-3

Standby Mode	2-2
Startup Splash Screen	2-3
Storage	B-3
storage environment	B-3
Sweep Icon	4-20
SWR	4-35
System Icon	4-20

T

temperature, operating	2-1
time, warm-up	2-3
Toolbar	4-28
Tr->Max Icon	4-20
Tr->Next Icon	4-21
TRACE Drop-Down Menu	4-11
Trace Icon	4-20
Trace Label Abbreviations	4-38
Traces	4-5

U

Unpacking the Product	2-1
User Input	1-4
User Interface Navigation	1-4

V

ventilation	2-1
Verification Kits	1-3
VNA models	1-1
voltage, of power supply	2-1

W

Warm-up Time	2-3
warm-up time	2-3

Anritsu



Anritsu utilizes recycled paper and environmentally conscious inks and toner.

Anritsu Company
490 Jarvis Drive
Morgan Hill, CA 95037-2809
USA
<http://www.anritsu.com>