

MS412FE/MS518SE/MS614E/MS614SE/MS621FE/MS920SE

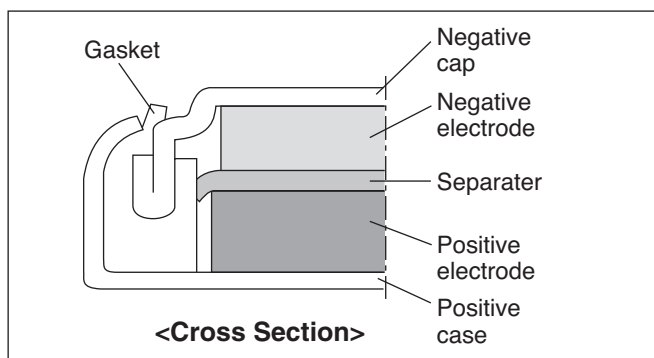

MS (Manganese Silicon) lithium rechargeable batteries, developed by Seiko Instruments Inc., use silicon oxide as the anode and a lithium manganese composite oxide as the cathode. As a result, they offer long cycle life and highly stable overdischarge characteristics.



FEATURES

- Large discharge capacity :
For high operational voltage range of 3.3V to 2.0V.
- Long cycle life :
Cycle life of over 100 cycles under charge/discharge conditions of 3.3V to 2.0V (D.O.D.100%).
- Excellent overdischarge characteristics :
Continued stable capacity characteristics even after the battery is overdischarged down to 0.0V.
- Operation over a wide temperature range:
Operating temperature range : -20°C to +60°C
Consult us for using the battery at a temperature beyond the above temperature range.
- RoHS Compliant

APPLICATIONS

- Backup power supply for memory or clock function in various types of electronic equipment for mobile communication, office automation, audio-visual equipment, mobile information equipment, etc. (cellphone, PHS, cordless phone, pager, memory card, fax machine, PC, video camera, digital camera, tuner, handy terminal, PDA, etc.)
- Hybrid power supply in combination with solar cells.
- Main power supply for small and slim portable equipment.

SPECIFICATIONS

Type	Nominal Voltage (V)	Charge Voltage (Standard Charge Voltage) ^{*6} (V)	Nominal Capacity (mAh) ^{*1}	Internal Impedance (Ω) ^{*2}	Standard Charge/Discharge Current (mA)	Maximum Discharge Current (Continuous) (mA) ^{*3}	Cycle Life (Time) ^{*4}		Size (mm)		Weight (g)
							100% ^{*5} D.O.D. (Depth of Discharge)	20% ^{*5} D.O.D. (Depth of Discharge)	Diameter	Height	
MS412FE	3	2.8 to 3.3 (3.1)	1.0	100	0.010	0.10	100	1000	4.8	1.2	0.07
MS518SE	3	2.8 to 3.3 (3.1)	3.4	60	0.010	0.15	100	1000	5.8	1.8	0.13
MS614E	3	2.8 to 3.3 (3.3)	2.3	50	0.015	0.25	100	1000	6.8	1.4	0.17
MS614SE	3	2.8 to 3.3 (3.1)	3.4	80	0.015	0.25	100	1000	6.8	1.4	0.17
MS621FE	3	2.8 to 3.3 (3.1)	5.5	80	0.015	0.25	100	1000	6.8	2.1	0.23
MS920SE	3	2.8 to 3.3 (3.1)	11.0	35	0.050	0.80	100	1000	9.5	2.1	0.47

*1. Nominal capacity: Typical value of discharge capacity between 3.1V and 2.0V
(Note that the discharge capacity of MS614E is between 3.3V and 2.0V.)

*2. Internal impedance is measured using an AC (Alternating Current) method at the fully charged state.

*3. Maximum discharge current indicates the value of a current for approximately 50% of the nominal capacity.

*4. Cycle Life indicates the times charge/discharge is repeated for approximately 50% of the capacity values in the specification sheet.

*5. 100% and 20% are based on nominal capacity.

*6. A constant voltage charge is recommended, but due to a limit in charge current, it is necessary to insert a resistor to regulate the charge current.

Contact us for further details.

If a constant current charge is required, contact us for more information.

DISCHARGE CHARACTERISTICS (CHARGE VOLTAGE DEPENDENCE)

MS412FE

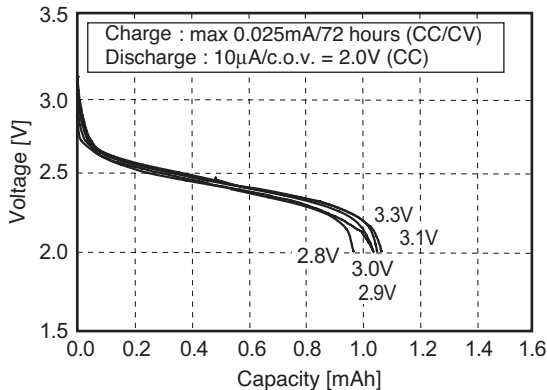

MS518SE

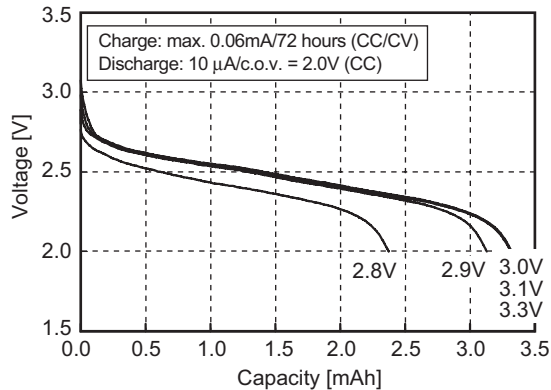

MS614E

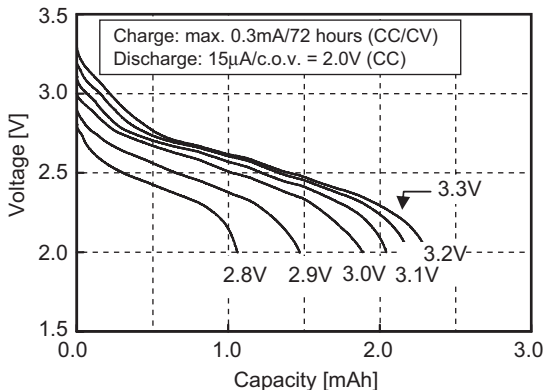

MS614SE

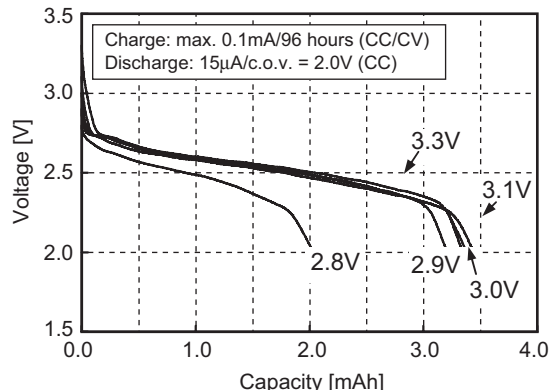

MS621FE

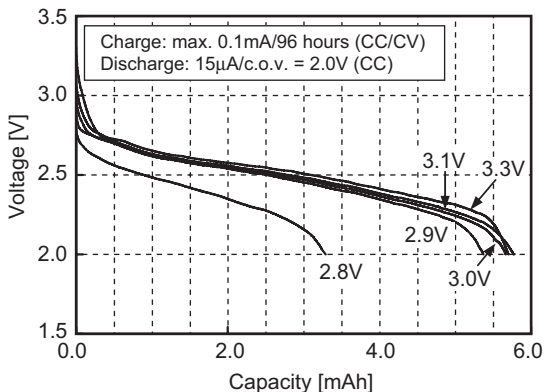

MS920SE

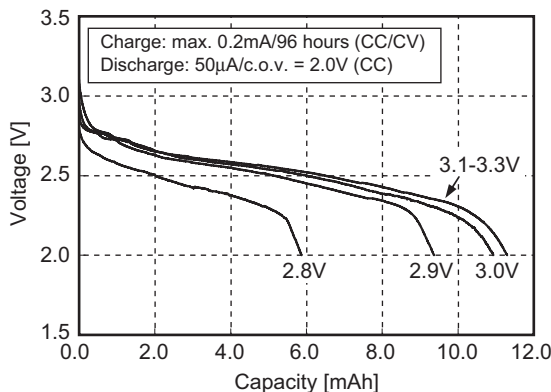

* c.o.v. : Cut Off Voltage (final voltage)

CHARACTERISTICS (MS614SE)

Charge/discharge characteristics

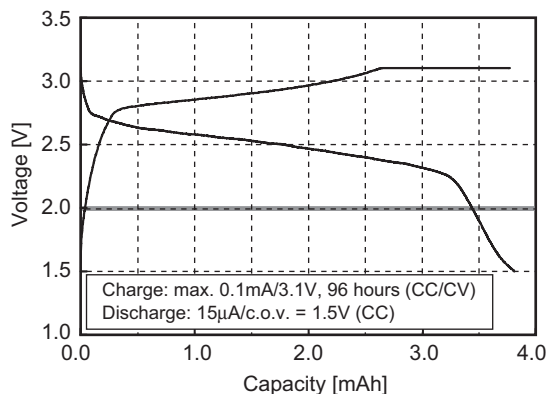

Discharge Characteristics at Various Discharge Current

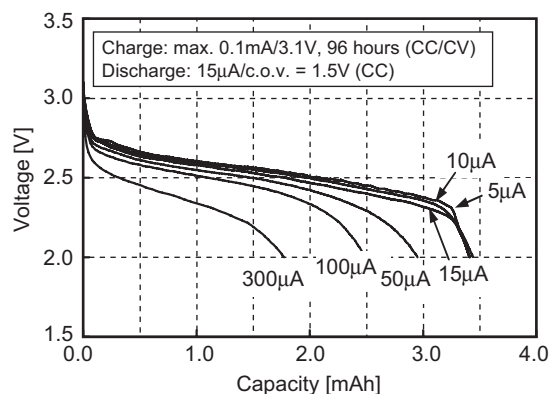

CHARACTERISTICS (MS614SE)

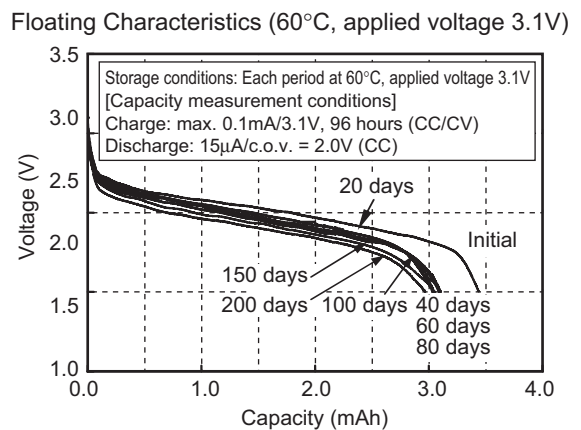
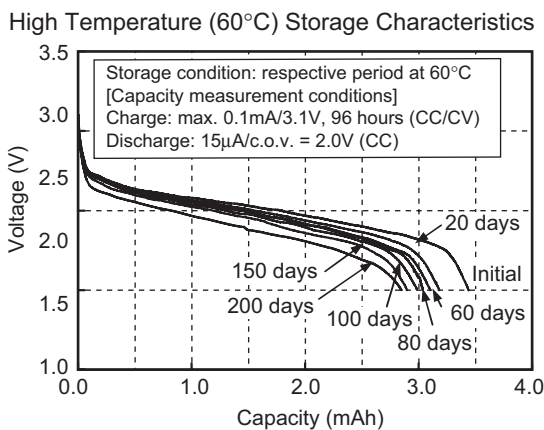
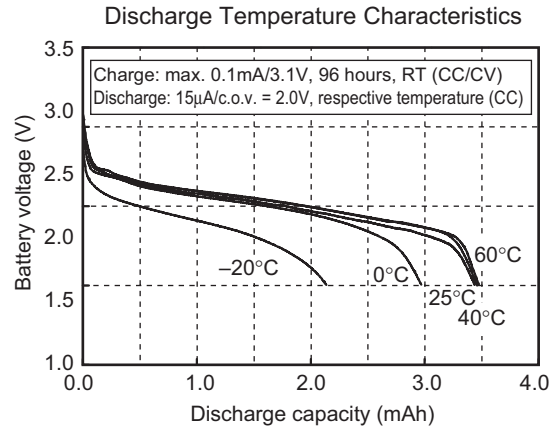
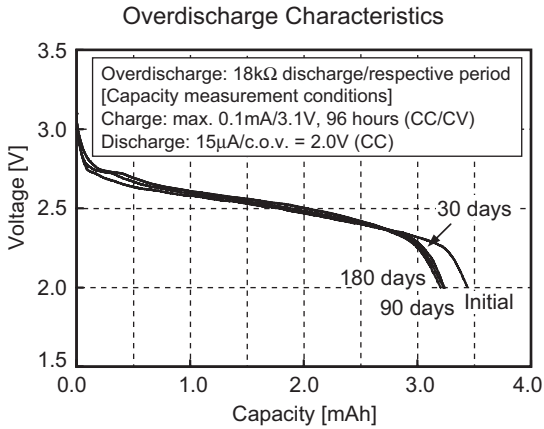

DIMENSIONS OF STANDARD TERMINALS OF MS LITHIUM RECHARGEABLE BATTERIES

Recommend

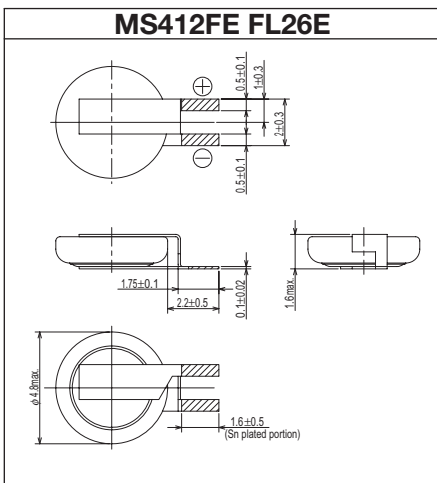

Recommend

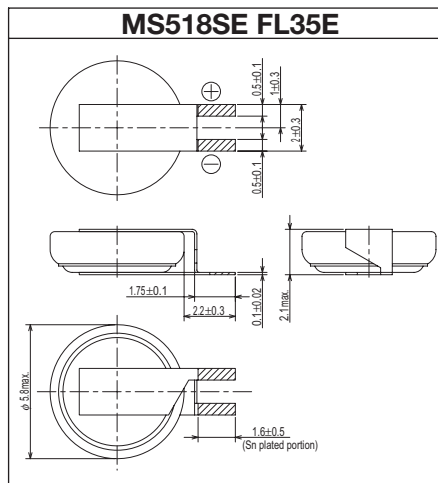

MS412FE IL21E

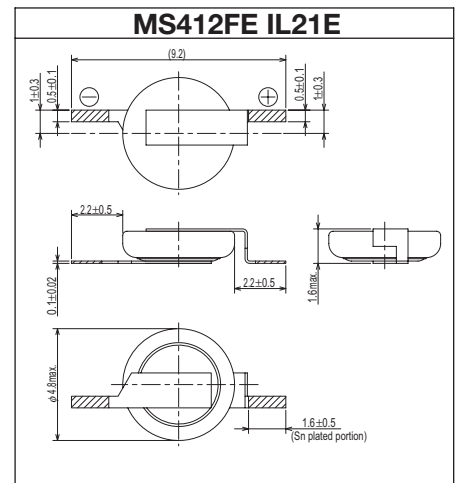

- Contact Seiko Instruments Inc. for batteries with terminals other than the above shapes.
- Units: mm
- The hatched parts are tin plated (Sn: 100%).

DIMENSIONS OF STANDARD TERMINALS OF MS LITHIUM RECHARGEABLE BATTERIES

Recommend

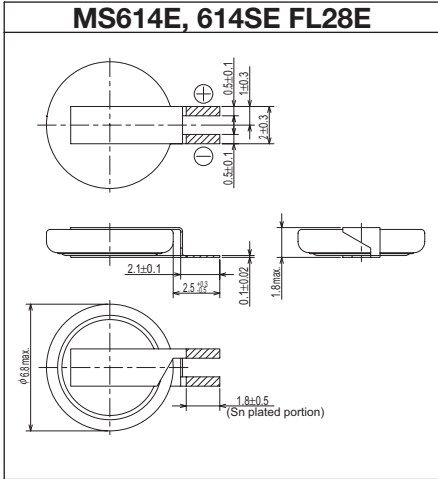

Recommend

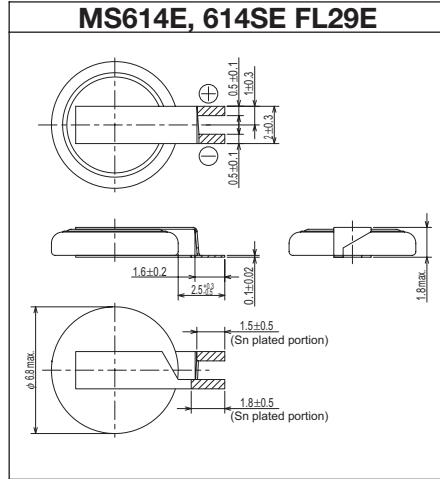

Recommend

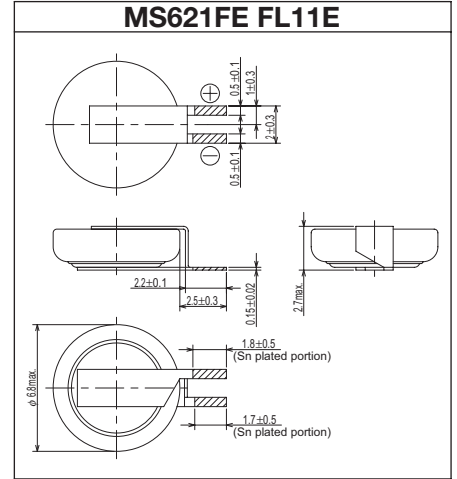

Recommend

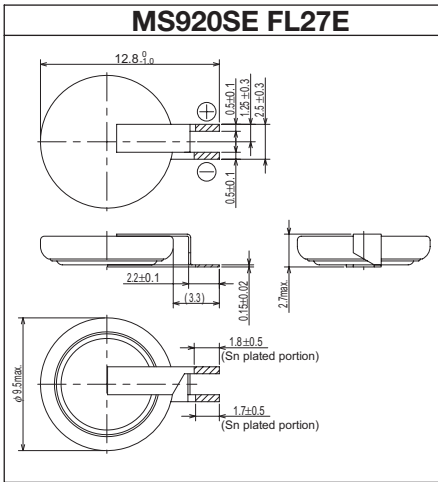

MS614E, 614SE IL38E

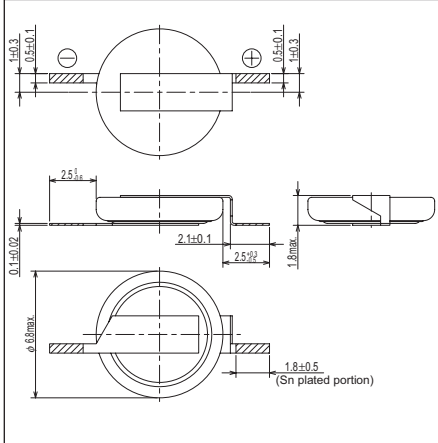

MS621FE IL36E

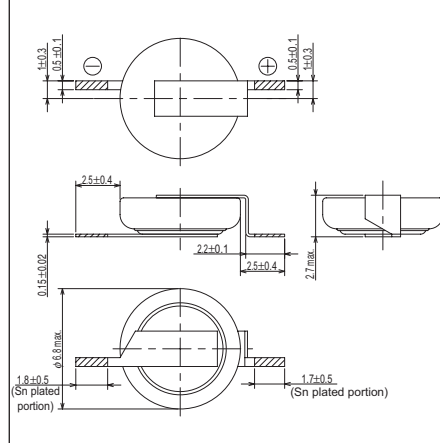

MS920SE IL37E

