

MS51957D  
25 April 1997  
Superseding  
MS51957C  
18 July 1986

MILITARY SPECIFICATION SHEET

SCREW, MACHINE, PAN HEAD, CROSS-RECESSED,  
CORROSION RESISTANT STEEL, UNC-2A

This specification is approved for use by all Departments  
and Agencies of the Department of Defense.

The requirements for acquiring the product described herein shall consist  
of this specification sheet and the issue of the following specification listed  
in that issue of the Department of Defense Index of Specifications and  
Standards (DoDISS) specified in the solicitation: FF-S-92.

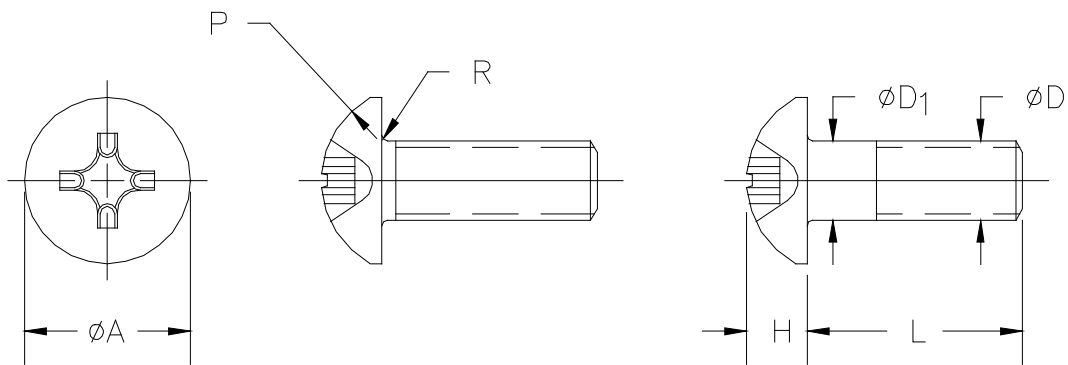

Ⓓ Entire document revised

MS51957D

Table I. Dimensions and Dash Numbers.

ØD Nominal Size		.0860	.1120	.1380	.1640	.1900	.2500	.3125	.3750
Threads Per Inch UNC-2A		56	40	32	32	24	20	18	16
Ø D <sub>1</sub> Body Diameter	Max	.0860	.1120	.1380	.1640	.1900	.2500	.3125	.3750
	Min	.0717	.0925	.1141	.1399	.1586	.2127	.2712	.3287
ØA Head Diameter	Max	.1670	.2190	.2700	.3220	.3730	.4920	.6150	.7400
	Min	.1550	.2050	.2560	.3060	.3570	.4730	.5940	.7160
H Head Height	Max	.0620	.0800	.0970	.1150	.1330	.1750	.2180	.2610
	Min	.0530	.0700	.0870	.1050	.1220	.1620	.2030	.2440
P Head Radius	Ref	.0100	.0100	.0150	.0150	.0200	.0350	.0400	.0400
R Fillet Radius	Max	.0130	.0170	.0210	.0250	.0290	.0380	.0470	.0560
Driver Size		1	1	2	2	2	3	4	4
Tensile Strength Lbs-Min		300	480	730	1,120	1,400	2,540	4,190	6,200
L Length	Tolerance	Dash No.	Dash No.	Dash No.	Dash No.	Dash No.	Dash No.	Dash No.	Dash No.
.125	+0 -.031	1	11	24	39				
.188		2	12	25	40	58 <sup>1/</sup>			
.250		3	13	26	41	59			
.312		4	14	27	42	60	76		
.375		5	15	28	43	61	77	92	
.438		6	16	29	44	62	78	93	
.500		7	17	30	45	63	79	94	107
.562		141 <sup>2/</sup>	120 <sup>2/</sup>	123 <sup>2/</sup>	126 <sup>2/</sup>	129 <sup>2/</sup>	132 <sup>2/</sup>	135 <sup>2/</sup>	138 <sup>2/</sup>
.625		8	18	31	46	64	80	95	108
.750		9	19	32	47	65	81	96	109
.875	10	20	33	48	66	82	97	110	
1.000	142 <sup>2/</sup>	21	34	49	67	83	98	111	
1.125	+0 -.062		121 <sup>2/</sup>	124 <sup>2/</sup>	127 <sup>2/</sup>	130 <sup>2/</sup>	133 <sup>2/</sup>	136 <sup>2/</sup>	139 <sup>2/</sup>
1.250			22 <sup>1/</sup>	35	50	68	84	99	112
1.375			122 <sup>2/</sup>	125 <sup>2/</sup>	128 <sup>2/</sup>	131 <sup>2/</sup>	134 <sup>2/</sup>	137 <sup>2/</sup>	140 <sup>2/</sup>
1.500			23	36	51	69	85	100	113
1.750				37	52	70	86	101	114
2.000				38	53	71	87	102	115
2.250	+0 -.094				54	72	88	103	116
2.500					55	73	89	104	117
2.750					56	74 <sup>1/</sup>	90 <sup>1/</sup>	105 <sup>1/</sup>	118
3.000					57	75 <sup>1/</sup>	91 <sup>1/</sup>	106 <sup>1/</sup>	119

<sup>1/</sup> Indicates manufacturer's non-stock production items

<sup>2/</sup> Inactive for new design after 18 July 1986

REQUIREMENTS:

1. **MATERIAL:** Austenitic Corrosion-Resistant Steel screws shall be manufactured from Type 302 (UNS S30200), Type 304 (UNS S30400), Type 304L (UNS S30403), Type 305 (UNS S30500), Type 316 (UNS S31600), Type 316L (UNS S31603), Type 384 (UNS S38400), or Type XM-7 (UNS S30430) in accordance with chemical composition specified in QQ-S-763. (See Material Identification Marking and Material Code).

2. **FINISH:** Passivate in accordance with QQ-P-35 or Black Oxide coating (except for Type 316 or Type 316L) in accordance with MIL-C-13924, Class 4. (See Finish Code).

3. **MECHANICAL PROPERTIES:** The minimum tensile strength in load pounds, indicated for each size in Table I, is based on 80,000 PSI Minimum Tensile Strength. Load pounds are calculated by the stress areas indicated in FED-STD-H28/2. The yield strength, based on .2 percent offset, shall be 30,000 psi minimum.

## Requirements: (Continued)

4. **MAGNETIC PERMEABILITY:** When specified, screws shall have a magnetic permeability of less than 2.0 maximum (air = 1.0) for a field strength H=200 Oersteds using a magnetic permeability indicator per ASTM A 342. Note: Cold working screws may not be capable of meeting permeability and strength requirements simultaneously.
5. **THREADS:** Screw threads shall be Unified external threads Class 2A UNC in accordance with FED-STD-H28/2. Acceptability of screw threads shall be in accordance with FED-STD-H28/20. Threads shall extend to within two threads or less of the bearing surface of the head, except that all lengths over 2.000 inches shall have a minimum complete thread length of 1.750 inches.
6. **RECESS:** Recess shall be in accordance with MS9006.
7. **MATERIAL IDENTIFICATION MARKING:** Type 316 (UNS S31600) or Type 316L (UNS S31603) CRES screws nominal size #10 (.1900) and larger shall be permanently marked "316". Markings shall be raised or depressed on the screw head at manufacturer's option.
8. **MATERIAL CODE:**  
 For 300 Series CRES - No code after dash number indicates any 300 Series Austenitic Corrosion-Resistant Steel listed in material requirement  
 For Type 316 or Type 316L CRES - "S316" after dash number indicates Austenitic Corrosion-Resistant Steel Type 316 or Type 316L.
9. **FINISH CODE:**  
 Passivate - No code letter after dash number, or after material code (if applicable) indicates passivate.  
 Black Oxide - "B" after dash number, (not available for Type 316 or Type 316L CRES), indicates black oxide coating.
10. **PART NUMBER:** The part number shall consist of the basic MS number, followed by a dash number from Table I, a material code (if applicable), and a finish code (if applicable).

## Examples:

- MS51957-1 indicates Screw, Machine-Pan Head, Cross-Recessed, Optional 300 Series CRES, Passivated; .0860-56 UNC-2A Nominal Thread Size, .125 Length
- MS51957-1B indicates Screw, Machine-Pan Head, Cross-Recessed, Optional 300 Series CRES, Black Oxide Coated; .0860-56 UNC-2A Nominal Thread Size, .125 Length
- MS51957-1S316 indicates Screw, Machine - Pan Head, Cross-Recessed, Type 316 or Type 316L CRES, Passivated; .0860-56 UNC-2A Nominal Thread Size, .125 Length

## NOTES:

1. All dimensions are in inches.
2. Interpret drawing in accordance with ASME Y14.5M.
3. In the event of a conflict between the text of this document and the references cited herein, the text of this document shall take precedence.
4. Unless otherwise specified, issues of referenced documents are those in effect at the time of solicitation.
5. MS51957 Pan Head Machine Screws manufactured prior to 25 April 1997 may be used until stock is depleted.

### MS51957D

The screws covered by dash numbers given in MS16200, MS35216, MS35233, AN515 in part and AN526 in part are canceled/inactive after the dates indicated on the documents. Use the dash numbers given in the preceding sheets. The canceled screws cannot always replace the new screws and should be used until existing stock are depleted. Use only the new screws for design and replacement. Replacement should be in accordance with this table.

Table II. Interchangeability

CROSS REFERENCE OF PART NUMBERS						
CANCELED						NEW
MS16200 MS35233	MS35216	AN515		AN526		MS51957
DASH NUMBER						
1	1	C2R2	C2-2			1
2	2	C2R3	C2-3			2
3	3	C2R4	C2-4			3
4	4	C2R5	C2-5			4
5	5	C2R6	C2-6			5
6	6	C2R7	C2-7			6
7	7	C2R8	C2-8			7
8	8	C2R10	C2-10			8
9	9	C2R12	C2-12			9
10						10
11	10	C3R2 thru C3R16	C3-2 thru C3-16			2/
12	11	C4R3	C4-3			11
13	12	C4R4	C4-4			12
14	13	C4R5	C4-5			13
15	14	C4R6	C4-6			14
16	15	C4R7	C4-7			15
17	16	C4R8	C4-8			16
18	17	C4R10	C4-10			17
19	18	C4R12	C4-12			18
20	19	C4R14	C4-14			19
21	20	C4R16	C4-16			20
22		C4R18	C4-18			21 <sup>1/</sup>
23		C4R20	C4-20			22
24		C4R22	C4-22			22 <sup>1/</sup>
25		C4R24	C4-24			23
26		C4R26	C4-26			23 <sup>2/</sup>
27		C4R28	C4-28			2/
28		C5R3 thru C5R28	C5-3 thru C5-28			2/
29	21					24
30	22	C6R3	C6-3			25
31	23	C6R4	C6-4	C632R4	C632-4	26
32	24	C6R5	C6-5	C632R5	C632-5	27
33	25	C6R6	C6-6	C632R6	C632-6	28
34	26	C6R7	C6-7	C632R7	C632-7	29
35	27	C6R8	C6-8	C632R8	C632-8	30
36				C632R9	C632-9	123 <sup>1/</sup>
37	28	C6R10	C6-10	C632R10	C632-10	31
38	29	C6R12	C6-12	C632R12	C632-12	32
39	30	C6R14	C6-14	C632R14	C632-14	33
40	31	C6R16	C6-16	C632R16	C632-16	34
41		C6R18	C6-18	C632R18	C632-18	124 <sup>1/</sup>
42	32	C6R20	C6-20	C632R20	C632-20	35
43		C6R22	C6-22	C632R22	C632-22	125 <sup>1/</sup>
44	33	C6R24	C6-24	C632R24	C632-24	36
45		C6R26	C6-26	C632R26	C632-26	2/
46	34	C6R28	C6-28	C632R28	C632-28	37
47		C6R30	C6-30	C632R30	C632-30	2/
48	35	C6R32	C6-32	C632R32	C632-32	38
49		C6R36	C6-36	C632R36	C632-36	2/
50		C6R40	C6-40	C632R40	C632-40	2/
51				C632R44	C632-44	2/
52				C632R48	C632-48	2/

<sup>1/</sup> New dash numbers added 26 August 1968

<sup>2/</sup> No replacement

## MS51957D

Table II. Interchangeability (Continued)

CROSS REFERENCE OF PART NUMBERS						
CANCELED						NEW
MS16200 MS35233	MS35216	AN515		AN526		MS51957
DASH NUMBER						
39	36					39
40	37					40
41	38	C8R4	C8-4	C832R4	C832-4	41
42	39	C8R5	C8-5	C832R5	C832-5	42
43	40	C8R6	C8-6	C832R6	C832-6	43
44	41	C8R7	C8-7	C832R7	C832-7	44
45	42	C8R8	C8-8	C832R8	C832-8	45
46	43	C8R10	C8-10	C832R9 C832R10	C832-9 C832-10	126 <sup>1/</sup> 46
47	44	C8R12	C8-12	C832R12	C832-12	47
48	45	C8R14	C8-14	C832R14	C832-14	48
49	46	C8R16 C8R18	C8-16 C8-18	C832R16 C832R18	C832-16 C832-18	49 127 <sup>1/</sup>
50	47	C8R20 C8R22	C8-20 C8-22	C832R20 C832R22	C832-20 C832-22	50 128 <sup>1/</sup>
51	48	C8R24 C8R26	C8-24 C8-26	C832R24 C832R26	C832-24 C832-26	51 2/
52	49	C8R28 C8R30	C8-28 C8-30	C832R28 C832R30	C832-28 C832-30	52 2/
53	50	C8R32	C8-32	C832R32	C832-32	53
54		C8R36	C8-36	C832R36	C832-36	54
55		C8R40	C8-40	C832R40	C832-40	55
56		C8R44	C8-44	C832R44	C832-44	56
57		C8R48	C8-48	C832R48	C832-48	57
58						58
59	51	C10R4	C10-4	C1024R4	C1024-4	59
60	52	C10R5	C10-5	C1024R5	C1024-5	60
61	53	C10R6	C10-6	C1024R6	C1024-6	61
62	54	C10R7	C10-7	C1024R7	C1024-7	62
63	55	C10R8	C10-8	C1024R8	C1024-8	63 129 <sup>1/</sup>
64	56	C10R10	C10-10	C1024R10	C1024-10	64
65	57	C10R12	C10-12	C1024R12	C1024-12	65
66	58	C10R14	C10-14	C1024R14	C1024-14	66
67	59	C10R16 C10R18	C10-16 C10-18	C1024R16 C1024R18	C1024-16 C1024-18	67 130 <sup>1/</sup>
68	60	C10R20	C10-20	C1024R20	C1024-20	68
69	61	C10R22 C10R24 C10R26	C10-22 C10-24 C10-26	C1024R22 C1024R24 C1024R26	C1024-22 C1024-24 C1024-26	131 <sup>1/</sup> 69 2/
70	62	C10R28 C10R30	C10-28 C10-30	C1024R28 C1024R30	C1024-28 C1024-30	70 2/
71	63	C10R32	C10-32	C1024R32	C1024-32	71
72	64	C10R36	C10-36	C1024R36	C1024-36	72
73	65	C10R40	C10-40	C1024R40	C1024-40	73
74		C10R44	C10-44	C1024R44	C1024-44	74
75		C10R48	C10-48	C1024R48	C1024-48	75
76	66	C416R5	C416-5			76
77	67	C416R6	C416-6	C420R6	C420-6	77
78	68	C416R7	C416-7	C420R7	C420-7	78
79	69	C416R8	C416-8	C420R8 C420R9	C420-8 C420-9	79 132 <sup>1/</sup>
80	70	C416R10	C416-10	C420R10	C420-10	80
81	71	C416R12	C416-12	C420R12	C420-12	81
82	72	C416R14	C416-14	C420R14	C420-14	82
83	73	C416R16 C416R18	C416-16 C416-18	C420R16 C420R18	C420-16 C420-18	83 133 <sup>1/</sup>

1/ New dash numbers added 26 August 1968

2/ No replacement

## MS51957D

Table II. Interchangeability (Continued)

CROSS REFERENCE OF PART NUMBERS						
CANCELED						NEW
MS16200 MS35233	MS35216	AN515		AN526		MS51957
DASH NUMBER						
84	74	C416R20	C416-20	C420R20	C420-20	84
		C416R22	C416-22	C420R22	C420-22	134 <sup>1</sup>
85	75	C416R24	C416-24	C420R24	C420-24	85
		C416R26	C416-26	C420R26	C420-26	<sup>2/</sup>
86	76	C416R28	C416-28	C420R28	C420-28	86
		C416R30	C416-30	C420R30	C420-30	<sup>2/</sup>
87	77	C416R32	C416-32	C420R32	C420-32	87
88	78	C416R36	C416-36	C420R36	C420-36	88
89	79	C416R40	C416-40	C420R40	C420-40	89
90		C416R44	C416-44	C420R44	C420-44	90
91		C416R48	C416-48	C420R48	C420-48	91
92	80					92
93	81					93
94	82	C516R8	C516-8			94
95	83	C516R10	C516-10			95
96	84	C516R12	C516-12			96
97	85	C516R14	C516-14			97
98	86	C516R16	C516-16			98
		C516R18	C516-18			136 <sup>1</sup>
99	87	C516R20	C516-20			99
		C516R22	C516-22			137 <sup>1</sup>
100	88	C516R24	C516-24			100
		C516R26	C516-26			<sup>2/</sup>
101	89	C516R28	C516-28			101
		C516R30	C516-30			<sup>2/</sup>
102	90	C516R32	C516-32			102
103	91	C516R36	C516-36			103
104	92	C516R40	C516-40			104
105		C516R44	C516-44			105
106		C516R48	C516-48			106
107	93	C616R6	C616-6			107
108	94	C616R10	C616-10			108
109	95	C616R12	C616-12			109
110	96	C616R14	C616-14			110
111	97	C616R16	C616-16			111
		C616R18	C616-18			139 <sup>1</sup>
112	98	C616R20	C616-20			112
		C616R22	C616-22			140 <sup>1</sup>
113	99	C616R24	C616-24			113
		C616R26	C616-26			<sup>2/</sup>
114	100	C616R28	C616-28			114
		C616R30	C616-30			<sup>2/</sup>
115	101	C616R32	C616-32			115
116	102	C616R36	C616-36			116
117	103	C616R40	C616-40			117
118	104	C616R44	C616-44			118
119	105	C616R48	C616-48			119

<sup>1/</sup> New dash numbers added 26 August 1968

<sup>2/</sup> No replacement

Military Interests:

Custodians:

Army - AR  
Navy - YD1  
Air Force - 99

Preparing activity:  
DLA - IS

(Project 5305-2128)

Reviewer:

Army - AV, AT, GL, ME, MI  
Navy -MC, SH  
National Security Agency - NSA