

Dual 2W Power Amplifier, I²C interface Stereo Input with Volume Control

FEATURES

- Operation range: 2.4V ~ 6.5V
- Volume control range
Gain: 0 to 21dB, 3dB/step
Attenuation: 0 to -77.5dB, 1.25dB/step
- Output mode : Speaker(BTL)/Headphone(SE)
- BTL Output power
R_L=4Ω, 2W at 5V, 0.8W at 3.3V, 360mW at 2.4V
R_L=8Ω, 1.3W at 5V, 0.53W at 3.3V, 250mW at 2.4V
- SE Output power
R_L=32Ω, 93mW at 5V, 35mW at 3.3V, 15mW at 2.4V
- Control interface : I²C
- Excellent Power Supply Rejection Ratio(PSRR)
- Flexibility power management
- Component less
- Reduce pop noise circuit
- Housed in TSSOP16(enhanced thermal PAD) package

APPLICATIONS

Multimedia system, Portable Digital Audio.

DESCRIPTION

The MS6864 is low distortion stereo power amplifier (SE/BTL) integrated volume control. It can drive 2W of continuous average power into a dual 4Ω bridged-tied (BTL) speaker or 2 * 90mW into stereo 32Ω single ended (SE) headphone. The volume control offers wide range of gain and attenuation for stereo input. All of the functions are easy setting that can be set by I2C interface.

The MS6864 has good features for portable equipment, including wide voltage operation 2.4V~6.5V, low power consumption, power management, component less, make the MS6864 ideally suitable for use in the portable digital audio equipments.

BLOCK DIAGRAM

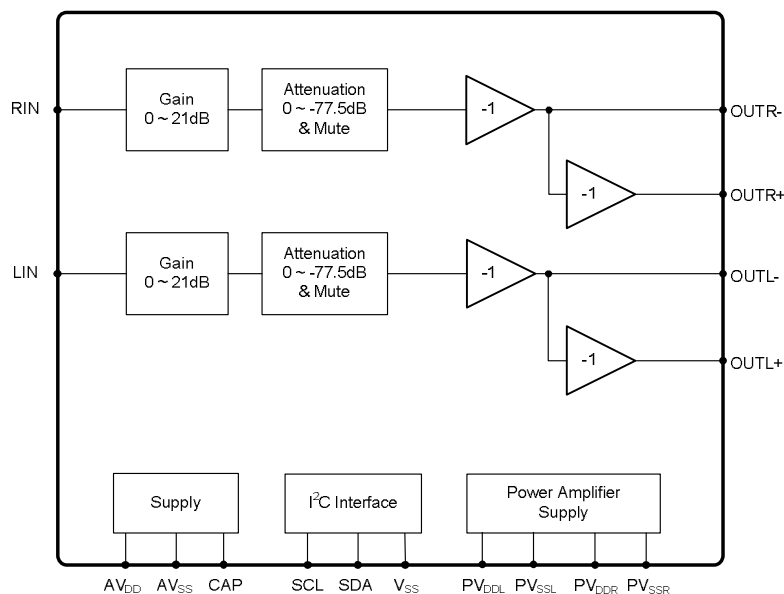

PIN CONFIGURATION

Symbol	Pin	Description
V _{SS}	1	Connected to ground
CAP	2	Capacitor connected
RIN	3	Right channel input
AV _{SS}	4	Negative supply voltage
OUTR-	5	SE right channel output or negative output of BTL right channel
PV _{DDR}	6	Positive supply voltage for right channel of power amplifier
OUTR+	7	Positive output of BTL right channel
PV _{SSR}	8	Negative supply voltage for right channel of power amplifier
PV _{SSL}	9	Negative supply voltage for left channel of power amplifier
OUTL+	10	Positive output of BTL left channel
PV _{DDL}	11	Positive supply voltage for left channel of power amplifier
OUTL-	12	SE left channel output or negative output of BTL left channel
AV _{DD}	13	Positive supply voltage
LIN	14	Left channel input
SDA	15	I ² C data input
SCL	16	I ² C clock input

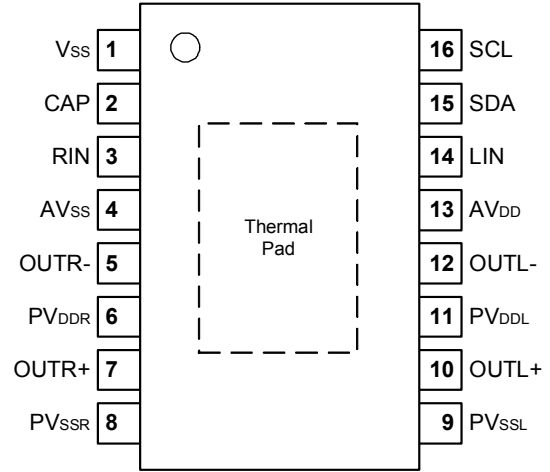

MS6864, TSSOP16

Note: 1. SE: Single Ended. BTL: Bridged-Tied Load

ORDERING INFORMATION

Package	Part number	Packaging Marking	Transport Media
16Pin TSSOP (lead free)	MS6864TGTR	MS6864G	2.5k Units Tape and Reel
16Pin TSSOP (lead free)	MS6864TGU	MS6864G	90 Units Tube

RoHS Compliance

ABSOLUTE MAXIMUM RATINGS

Symbol	Parameter	Rating	Unit
V _{DD}	Supply voltage	6.5	V
V _{ESD}	Electrostatic handling	2000	V
T _{STG}	Storage temperature range	-65 to 150	°C
T _A	Operating ambient temperature range	-40 to 85	°C
T _J	Maximum junction temperature	150	°C
T _S	Soldering temperature, 10 seconds	260	°C
R _{THJA}	Thermal resistance from junction to ambient in free air TSSOP16 (enhanced thermal pad)	51	°C/W

OPERATING RATINGS

Symbol	Parameter	Min	Typ	Max	Unit
V _{DD}	Supply voltage	2.4	5	6.5	V

5V ELECTRICAL CHARACTERISTICS

(T_a=25°C, V_{DD}=5V, V_{SS}=0V, f=1kHz; unless otherwise specified)

Symbol	Parameter	Conditions	Min	Typ	Max	Unit
DC Characteristics						
V _{CAP}	Voltage at CAP		0.5V _{DD} -0.05	0.5V _{DD}	0.5V _{DD} +0.05	V
V _{DC}	Output DC level		0.5V _{DD} -0.05	0.5V _{DD}	0.5V _{DD} +0.05	V
I _Q	Quiescent current	All devices are active, BTL	-	10	-	mA
		All devices are active, SE		6.7		
		L-ch (R-ch) PD, BTL		5.2		
		L-ch (R-ch) PD, SE		3.4		
I _{PD}	Power down current	All devices power down	-	-	0.3	uA
		All devices power down, except CAP=1/2 VDD		12		
ATT	Mute attenuation				-90	dB
G _{RAN}	Gain/Attenuation range	Gain	0	-	21	dB
		Attenuation	-77.5		0	dB
G _{STEP}	Gain step		-	3	-	dB
A _{STEP}	Attenuation step		-	1.25	-	dB
E _{GA}	Gain/Attenuation step error		-	0.3	-	dB
V _{I2CH}	Serial interface high input level		2			V
V _{I2CL}	Serial interface low input level				0.8	V
AC Characteristics						
PSRR	Power supply rejection ratio	BTL Mode, R _L =8Ω CAP=1uF, f=200Hz	-	61	-	dB
		SE Mode, R _L =32Ω CAP=1uF, f=200Hz	-	65	-	dB
CS	Channel separation	BTL Mode, R _L =8Ω Po=1W	-	78	-	dB
		SE Mode, R _L =32Ω Po=60mW	-	81	-	dB
THD+N	Total harmonic distortion plus Noise	SE mode, R _L =32Ω, 75mW	-	-65	-	dB
			-	0.0562	-	%
S/N	Signal-to-noise ratio	SE mode, A-weighting, 75mW	-	93	-	dB
P _o	Maximum output power	BTL Mode, R _L = 4Ω THD+N = 1%	-	2	-	W
		BTL Mode, R _L = 8Ω THD+N = 1%	-	1.3	-	W
		SE Mode, R _L = 32Ω THD+N = 0.1%	-	93m	-	W

PD: Power Down

3.3V ELECTRICAL CHARACTERISTICS

($T_a=25^\circ\text{C}$, $V_{DD}=3.3\text{V}$, $V_{SS}=0\text{V}$, $f=1\text{kHz}$; unless otherwise specified)

Symbol	Parameter	Conditions	Min	Typ	Max	Unit
DC Characteristics						
I_Q	Quiescent current	All devices are active, BTL	-	9	-	mA
		All devices are active, SE	-	6	-	
		L-ch (R-ch) PD, BTL	-	4.6	-	
		L-ch (R-ch) PD, SE	-	3.0	-	
AC Characteristics						
THD+N	Total harmonic distortion plus Noise	SE mode, $R_L=32\Omega$, 35mW	-	-65	60	dB
			-	0.0562	0.1	%
P_o	Maximum output power	BTL Mode, $R_L = 4\Omega$ THD+N = 1%	-	0.8	-	W
		BTL Mode, $R_L = 8\Omega$ THD+N = 1%	-	0.53	-	W
		SE Mode, $R_L = 32\Omega$ THD+N = 0.1%	-	35m	-	W

2.4V ELECTRICAL CHARACTERISTICS

($T_a=25^\circ\text{C}$, $V_{DD}=2.4\text{V}$, $V_{SS}=0\text{V}$, $f=1\text{kHz}$; unless otherwise specified)

Symbol	Parameter	Conditions	Min	Typ	Max	Unit
DC Characteristics						
I_Q	Quiescent current	All devices are active, BTL	-	7.6	-	mA
		All devices are active, SE	-	5.1	-	
		L-ch (R-ch) PD, BTL	-	4	-	
		L-ch (R-ch) PD, SE	-	2.6	-	
AC Characteristics						
THD+N	Total harmonic distortion plus Noise	SE mode, $R_L=32\Omega$, 15mW	-	-65	-60	dB
			-	0.0562	0.1	%
P_o	Maximum output power	BTL Mode, $R_L = 4\Omega$ THD+N = 1%	-	0.36	-	W
		BTL Mode, $R_L = 8\Omega$ THD+N = 1%	-	0.25	-	W
		SE Mode, $R_L = 32\Omega$ THD+N = 0.1%	-	15m	-	W

TYPICAL PERFORMANCE CHARACTERISTICS

(Ta=25°C; unless otherwise specified)

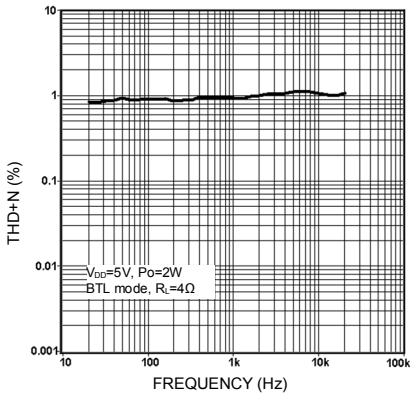

THD+N vs. frequency

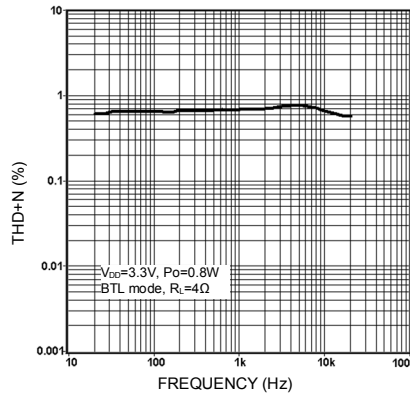

THD+N vs. frequency

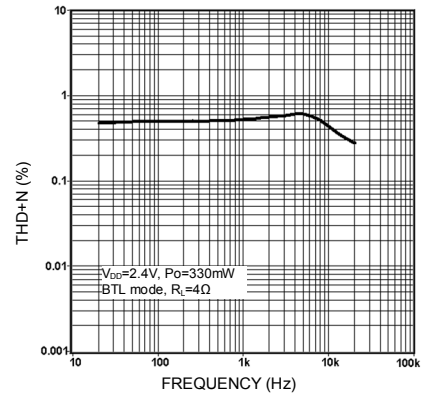

THD+N vs. frequency

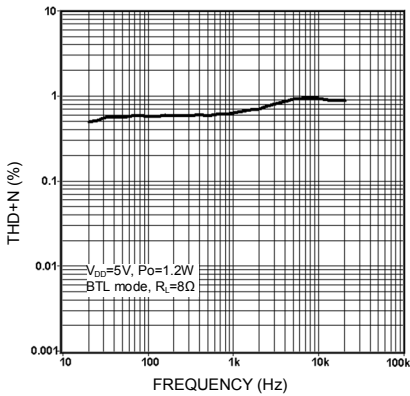

THD+N vs. frequency

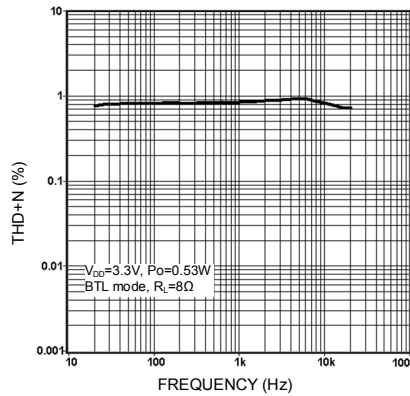

THD+N vs. frequency

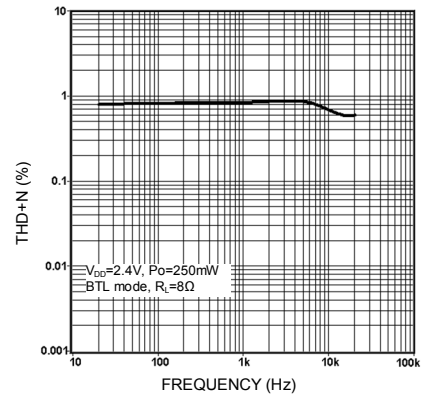

THD+N vs. frequency

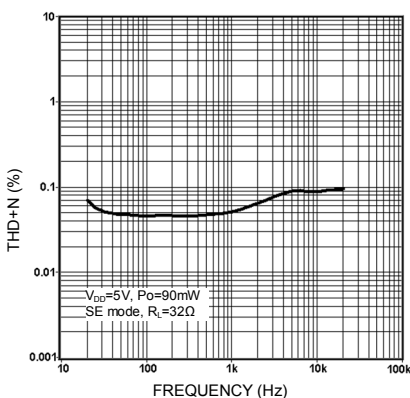

THD+N vs. frequency

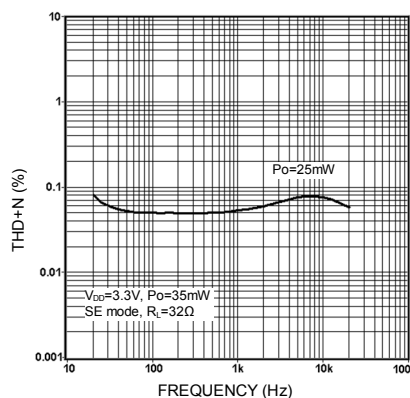

THD+N vs. frequency

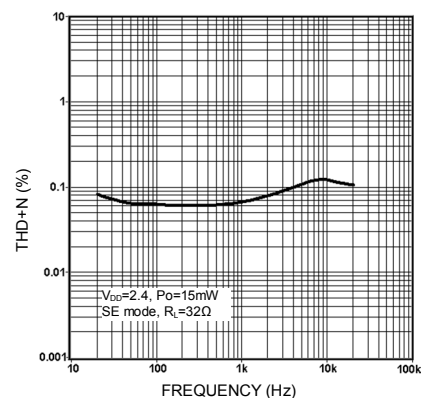

THD+N vs. frequency

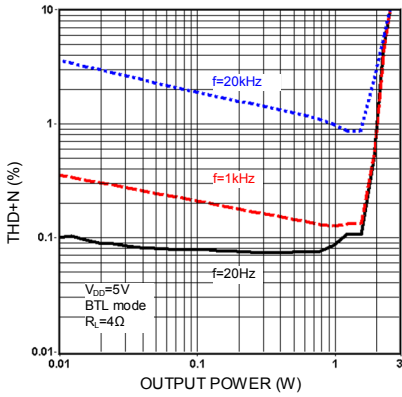

THD+N vs. output power

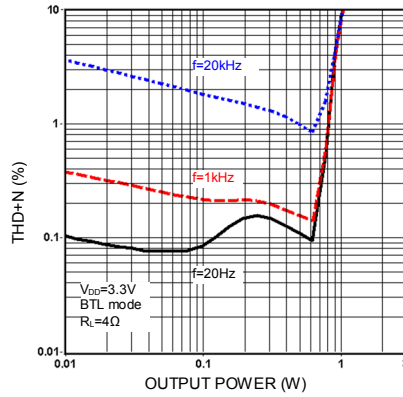

THD+N vs. output power

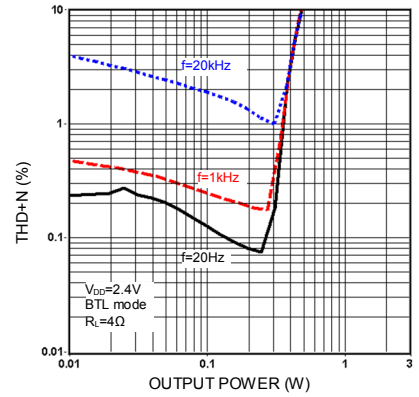

THD+N vs. output power

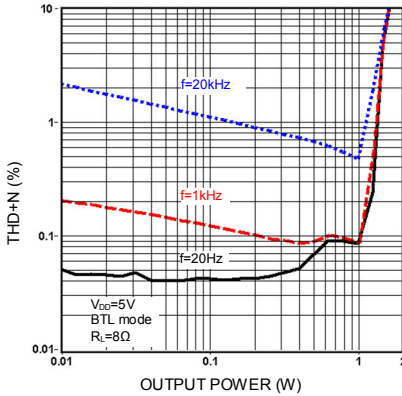

THD+N vs. output power

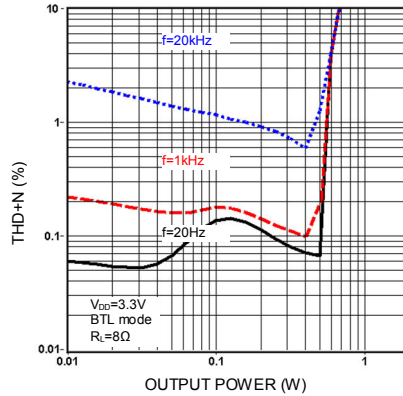

THD+N vs. output power

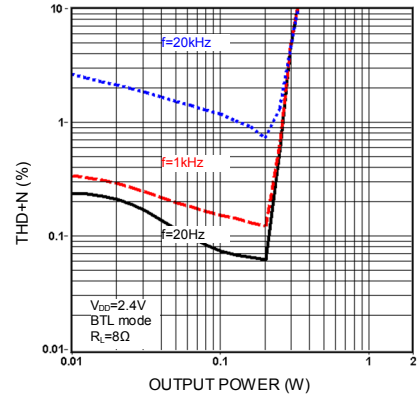

THD+N vs. output power

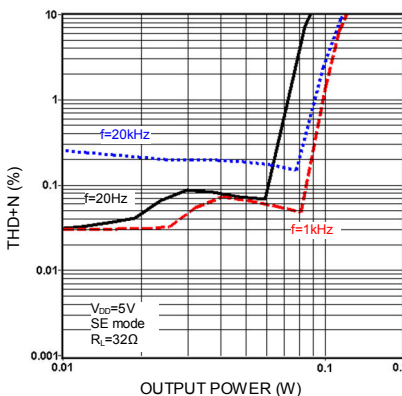

THD+N vs. output power

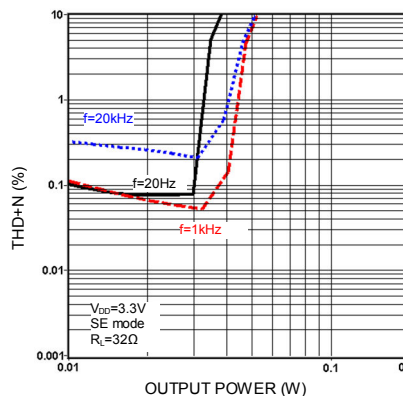

THD+N vs. output power

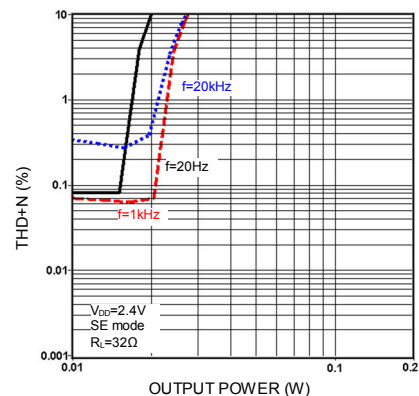

THD+N vs. output power

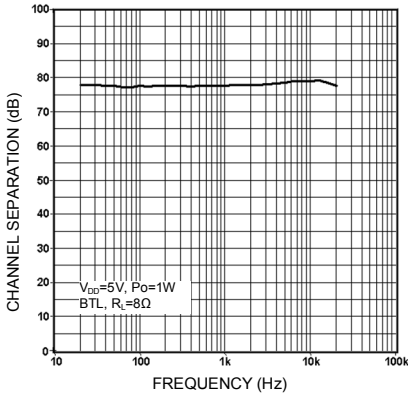

Channel separation vs. frequency

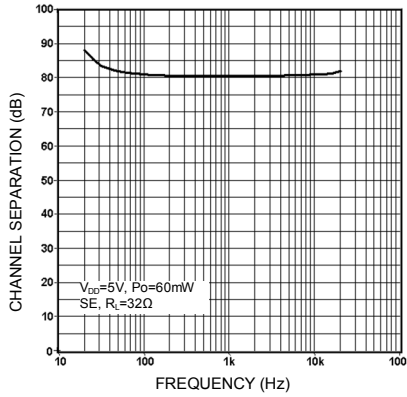

Channel separation vs. frequency

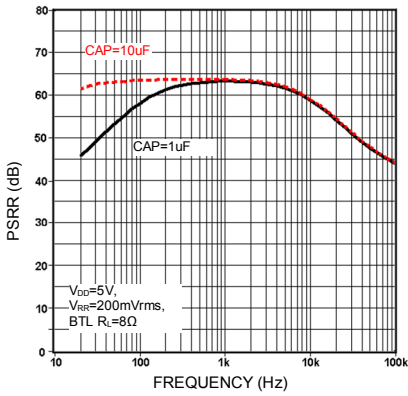

PSRR vs. frequency

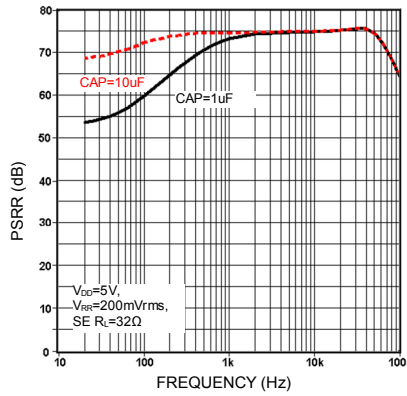

PSRR vs. frequency

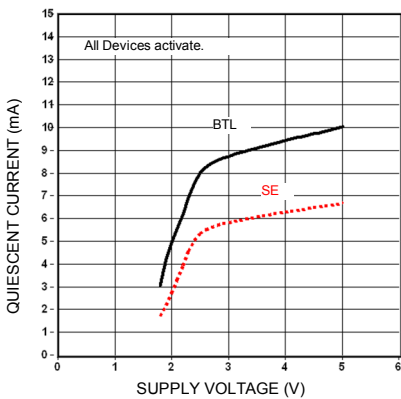

Quiescent current vs. supply voltage

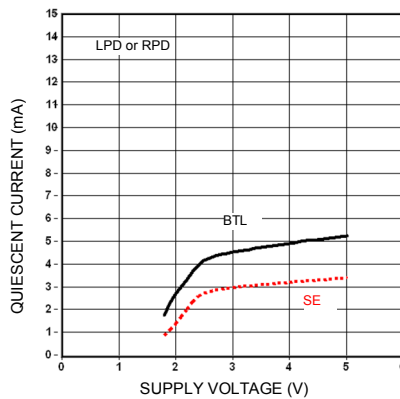

Quiescent current vs. supply voltage

I²C CONTROL INTERFACE

Data are transmitted to and from the MCU and MS6864 via the SDA and SCL. The SDA and SCL make up the BUS interface. It should be noted that pull-up resistors must be connected to the positive supply voltage.

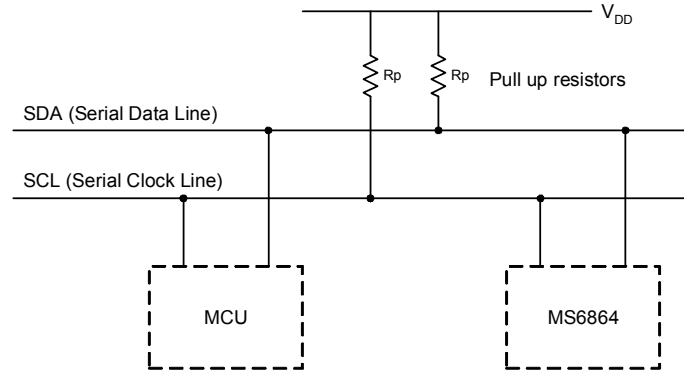

I²C interface protocol

The format consists of the following:

- A START condition
- A chip address byte including the chip address. (7bits)
- The 8th bit of the byte must be "0".(write=0, read=1)
- The chip must always acknowledge the end of each transmitted byte.
- A data sequence (N-bytes + Acknowledge)
- A STOP condition

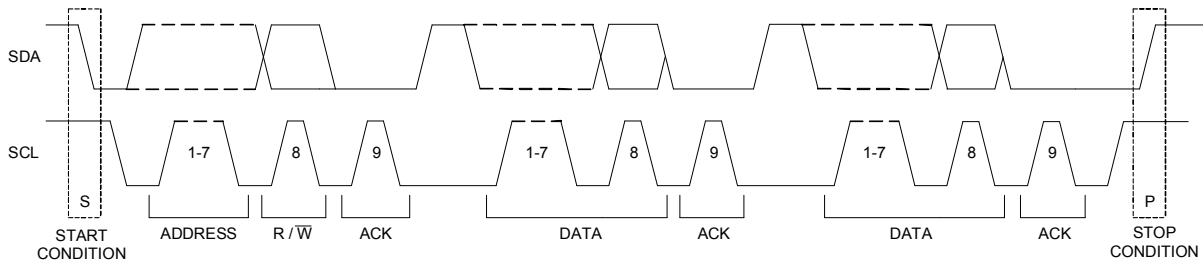

I²C chip address

88H

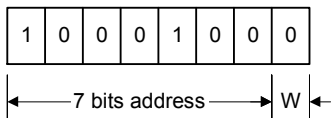

I²C data bytes description

MSB		LSB						Function
0	0	B2	B1	B0	A2	A1	A0	L-ch, Attenuation and Mute
0	1	B2	B1	B0	A2	A1	A0	R-ch, Attenuation and Mute
1	0	0	G2	G1	G0	0	0	L-ch, Input Gain
1	0	1	G2	G1	G0	0	0	R-ch, Input Gain
1	1	0	1	RPD	LPD	PDPR	CAP PD	Power Down Mode
1	1	1	S/B	0	0	0	0	Output mode (SE/BTL)

Where Ax = 1.25dB/step; Bx = 10dB/step; Gx = 3dB/step

Attenuation and Mute								Function
MSB		LSB						Function
0	0	B2	B1	B0	A2	A1	A0	L-ch, Attenuation and Mute
0	1							R-ch, Attenuation and Mute
					0	0	0	0 dB
					0	0	1	-1.25 dB
					0	1	0	-2.5 dB
					0	1	1	-3.75 dB
					1	0	0	-5 dB
					1	0	1	-6.25 dB
					1	1	0	-7.5 dB
					1	1	1	-8.75 dB
		0	0	0				0 dB
		0	0	1				-10 dB
		0	1	0				-20 dB
		0	1	1				-30 dB
		1	0	0				-40 dB
		1	0	1				-50 dB
		1	1	0				-60 dB
		1	1	1				-70 dB
		1	1	1	1	1	1	Mute

Initial state: Both L-ch and R-ch are mute-on.

Input Gain								
MSB							LSB	Function
1	0	0	G2	G1	G0	0	0	L-ch, Input Gain
1	0	1						R-ch, Input Gain
			0	0	0			0 dB
			0	0	1			3 dB
			0	1	0			6 dB
			0	1	1			9 dB
			1	0	0			12 dB
			1	0	1			15 dB
			1	1	0			18 dB
			1	1	1			21 dB

Initial state: Both L-ch and R-ch are 0dB gain.

Power Down Mode								
MSB							LSB	Function
1	1	0	1	RPD	LPD	PDPR	CAP PD	Power mode selection and power management
				0				R-ch PA output is active mode
				1				R-ch PA output is power down mode
					0			L-ch PA output is active mode
					1			L-ch PA output is power down mode
						0		Disable preparation for power off
						1		Enable preparation for power off
							0	Set the voltage of CAP to middle of supply voltage
							1	Pull down CAP pin to ground

Initial state: All are the power down modes.

Enable the power down preparation before the chip will be shut down.

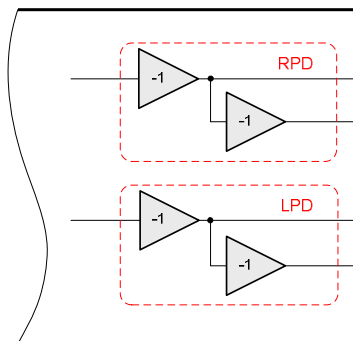

Output mode (SE/BTL)								
MSB							LSB	Function
1	1	1	S/B	0	0	0	0	Output mode, mixer control and audio format
			0					Output mode is BTL
			1					Output mode is SE

Initial state: Output mode is BTL mode.

I²C Initial code and status

MSB	LSB							Function	Initial status
0	0	1	1	1	1	1	1	L-ch, Attenuation and Mute	Mute On
0	1	1	1	1	1	1	1	R-ch, Attenuation and Mute	Mute On
1	0	0	0	0	0	0	0	L-ch, Input Gain	0dB
1	0	1	0	0	0	0	0	R-ch, Input Gain	0dB
1	1	0	1	1	1	1	1	Power Down Mode	All devices are power down
1	1	1	0	0	0	0	0	Output mode (SE/BTL)	BTL

I²C CODE EXAMPLE

Input gain

Set the left channel gain to be 3dB and the right channel gain to be 3dB

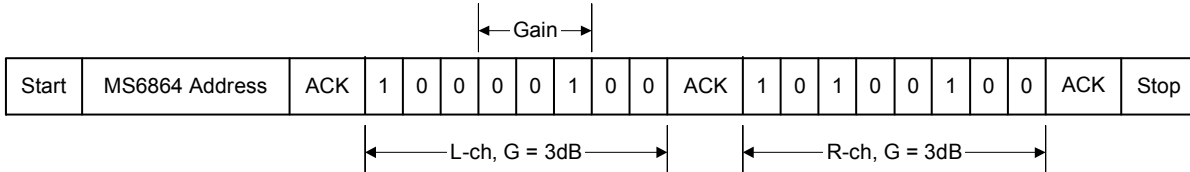

The left and right input channels are independent.

Input Attenuation

Set the left channel to be -15dB and the right channel to be -30dB

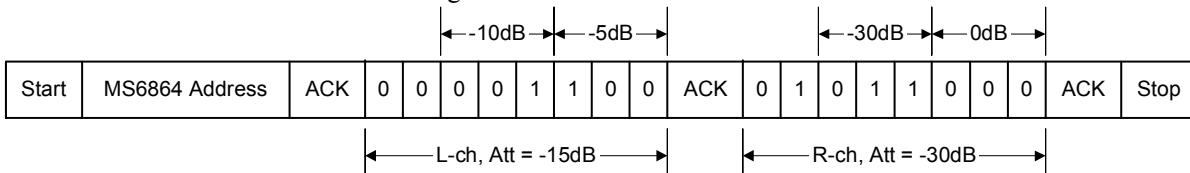

Power down mode

Set the L-ch PA output to be active mode.

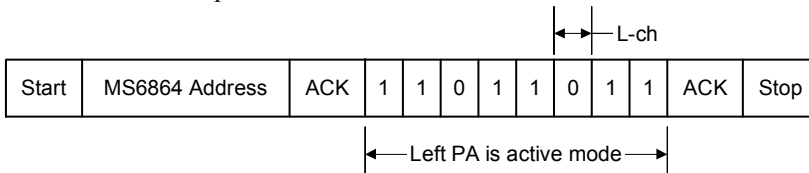

Output mode

Set the output mode to be BTL mode

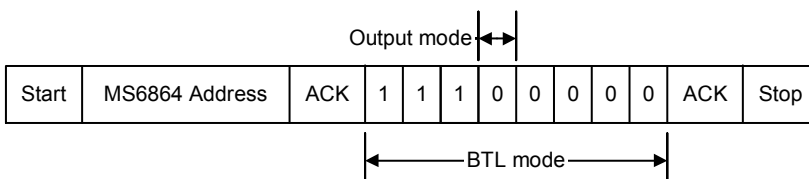

OPERATION PROCEDURE

The sequence of operation: power on → active → power down → active → power off. The basic flowcharts are as follows:

For HP mode and HP/BTL mode

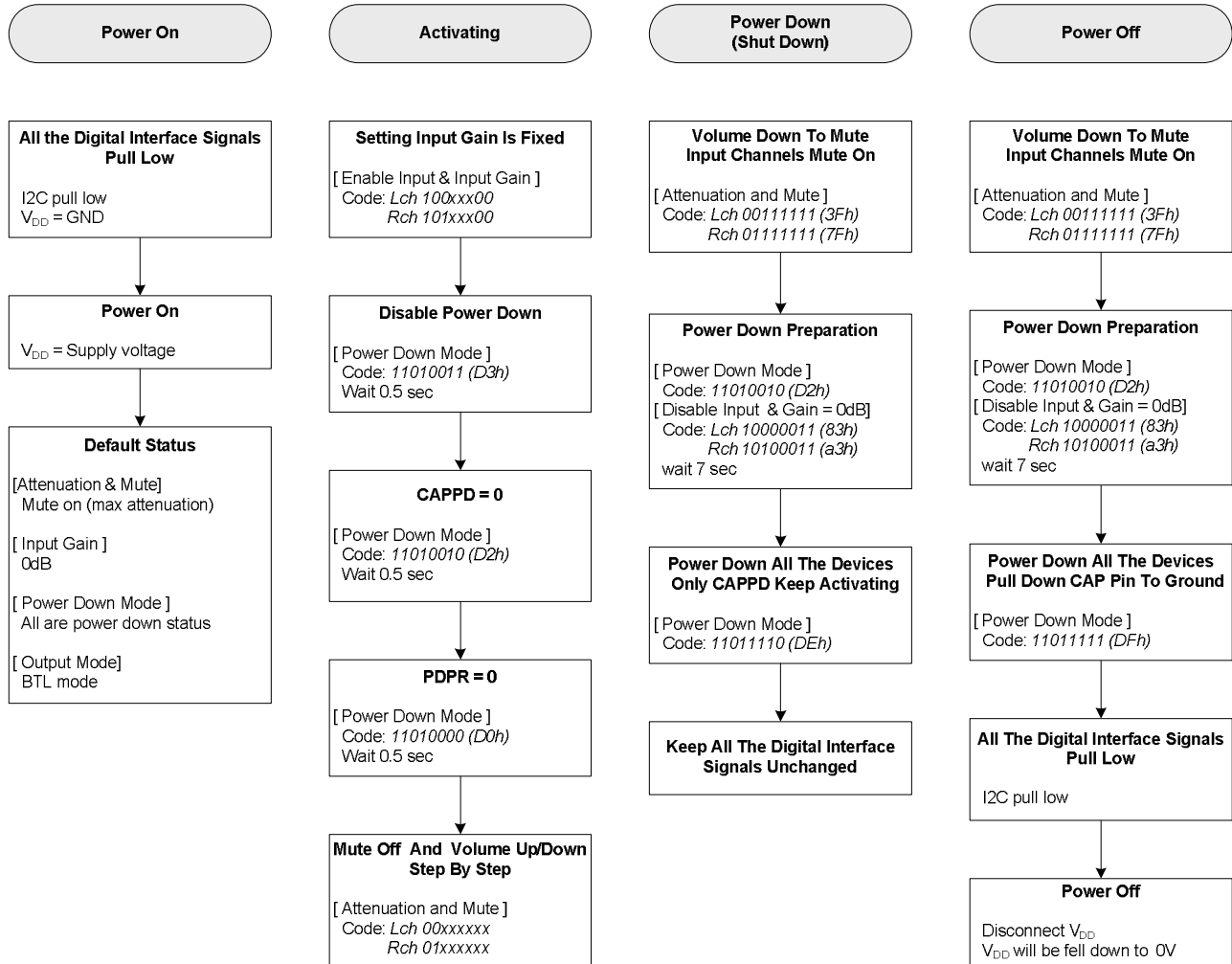

For BTL mode only

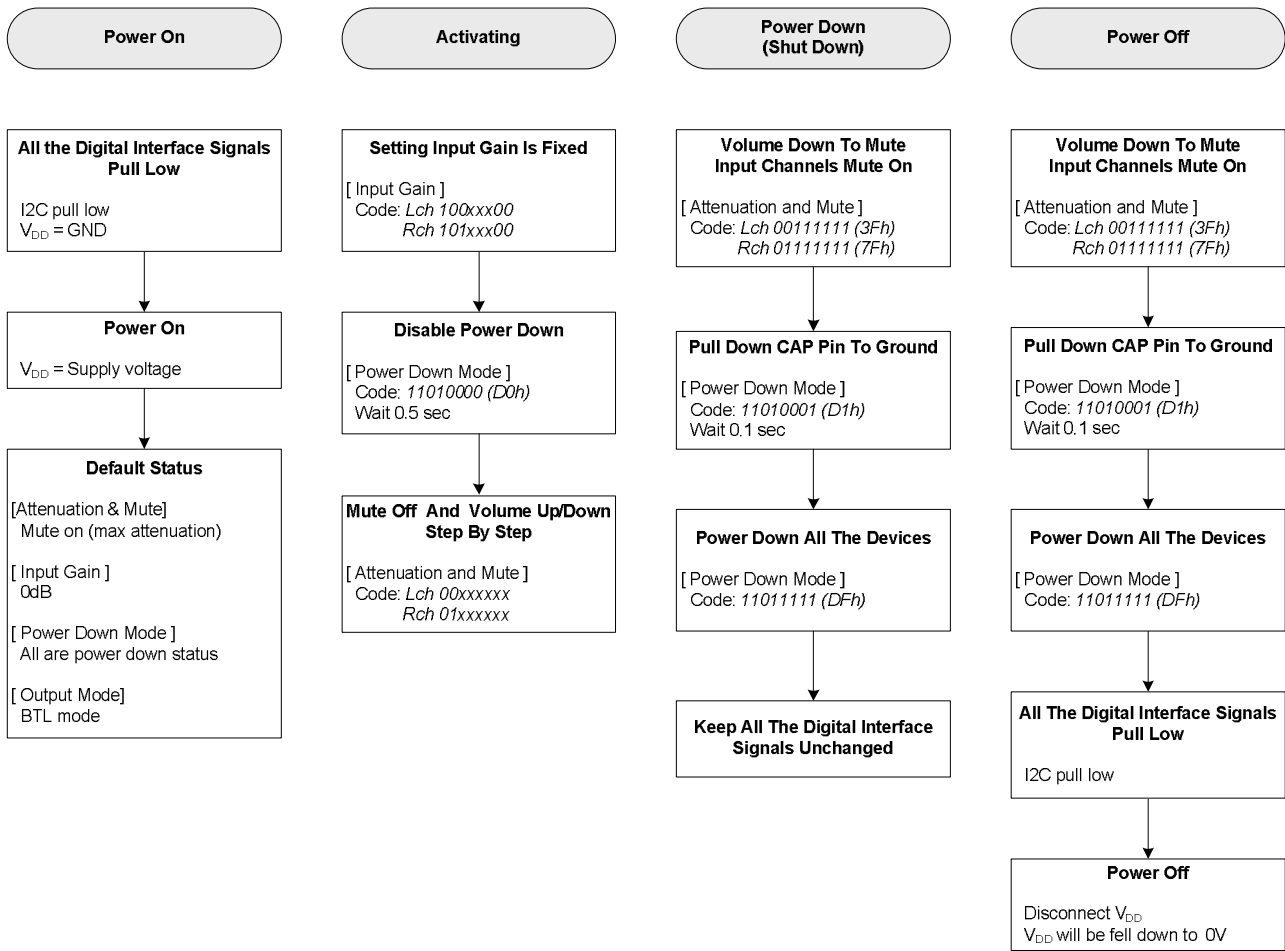

APPLICATION INFORMATION

A base application circuit

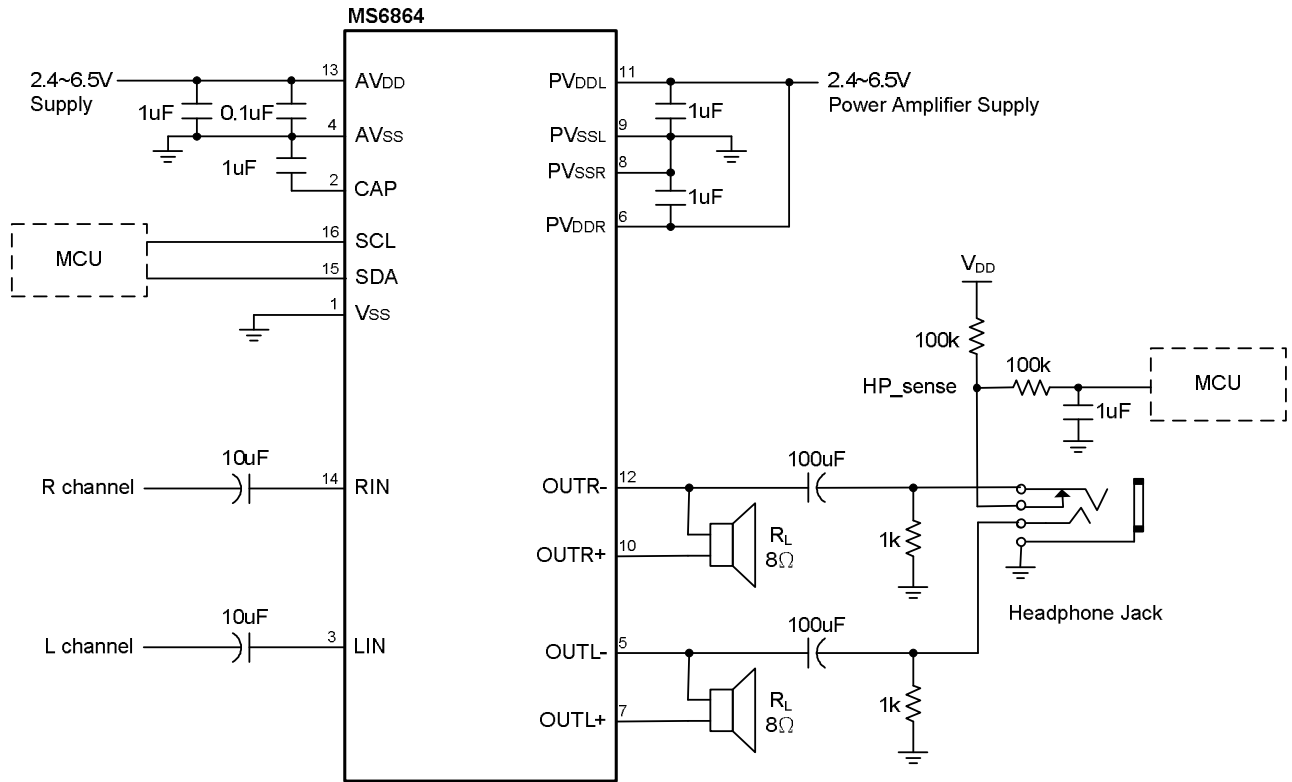

Output mode operation -- SE mode and BTL mode

The output has two modes, SE mode and BTL mode. The mode is selected by I2C code via MCU. In BTL mode, the outputs of A1(B1) and A2(B2) are then used to drive the speakers(4Ω/8Ω).

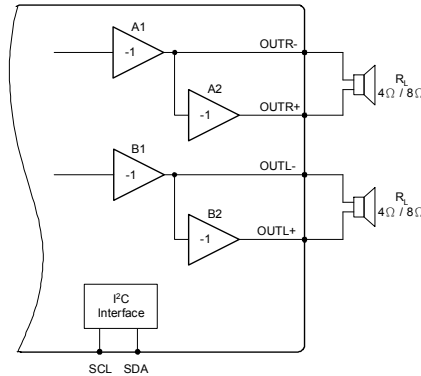

In the SE mode, the amplifiers A2 and B2 are shutdown, and become the high output impedance states.

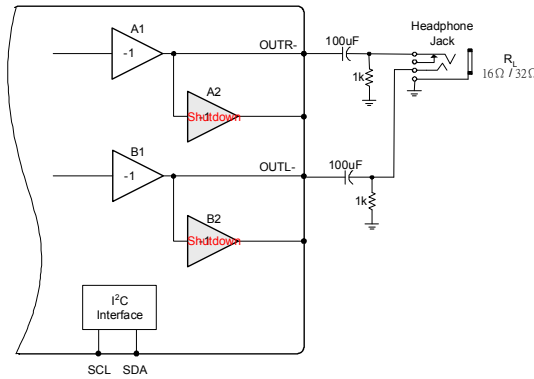

Headphone sense

The output mode is SE or BTL that is decided by a headphone. It has to be set SE mode when a headphone is plug-in status. The output mode is selected by I2C command code by MCU. Please note that the MS6864 don't detect a headphone automatically. Thus a detect function is executed via MCU. An operation diagram is shown as follows:

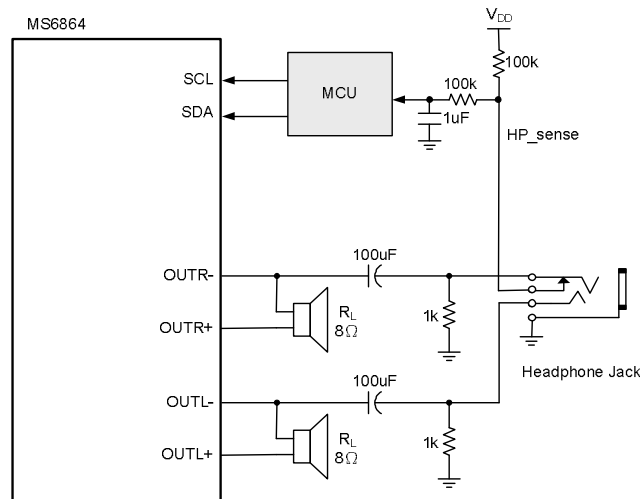

The HP_sense pin is high when a headphone is plug-in.
The HP_sense pin is low when a headphone is not plug-in.

EXTERNAL DIMENSIONS

TSSOP16 (Thermal Pad)

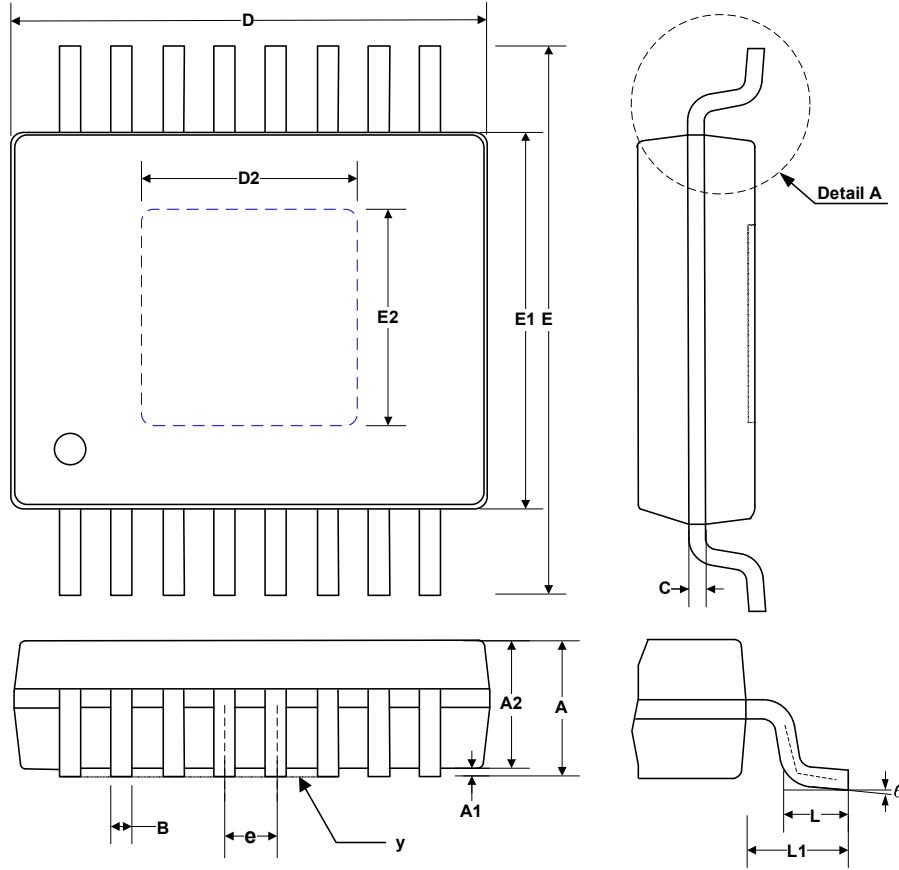

Symbol	Dimension in mm			Dimension in inches		
	Min	Nom	Max	Min	Nom	Max
A	-	-	1.2	-	-	0.047
A1	0.00	-	0.15	0.000	-	0.006
A2	0.80	1.00	1.05	0.031	0.039	0.041
b	0.19	-	0.30	0.007	-	0.012
C	0.09	-	0.20	0.004	-	0.008
D	4.90	5.00	5.10	0.193	0.197	0.201
D2	2.4	-	3	0.094	-	0.118
E	6.4 BSC			0.252 BSC		
E1	4.30	4.40	4.50	0.169	0.173	0.177
E2	2.4	-	3	0.094	-	0.118
e	0.65 BSC			0.0256 BSC		
L	0.45	0.60	0.75	0.018	0.024	0.030
L1	0.90	1.00	1.10	0.035	0.039	0.043
θ	0°	-	8°	0°	-	8°
y	-	-	0.10	-	-	0.004

DEMO BOARD

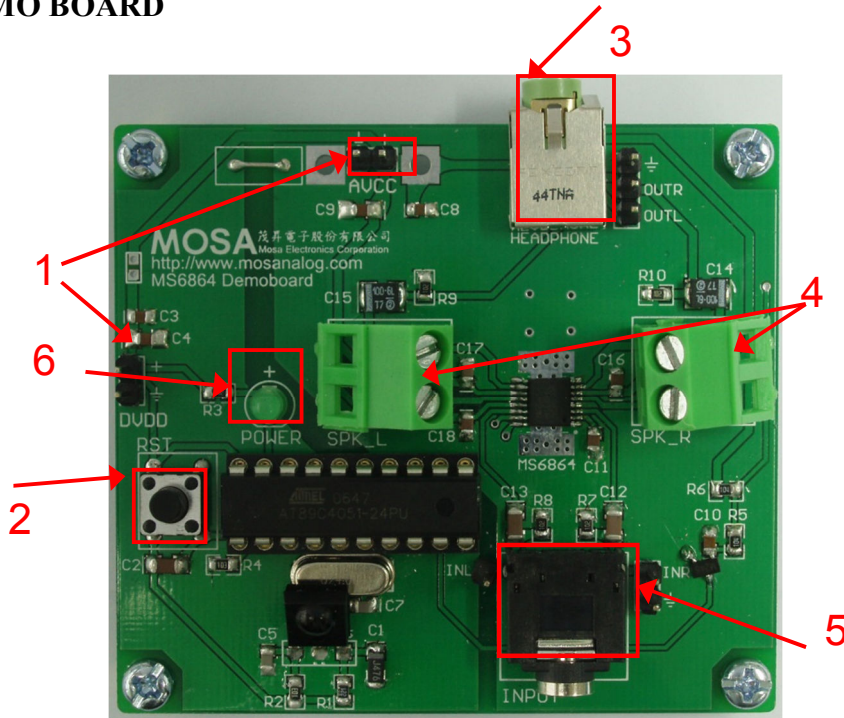

Function description

Label 1: Supply Input
Supply voltage range is 2.4V to 6.5V.

Label 2: Reset
All I/O pins are reset to default values.

Label 3: Headphone Jack
Used 3.5mm diameter of headphone with 32ohm

Label 4: Speaker Output
Connected to speaker with 8ohm or 4 ohm

Label 5: Signal Input
Connected to audio signals.

Label 6: LED Indicator
The LEDs indicate the chip status and IR received status.
Power ON status, it is green-dark blink twice and then keeps on a light state.
Power OFF status, it is green-dark blink four times and then keeps on a dark state.
It is green-dark blink once when the MCU has received the function code correctly.

SE mode and BTL mode operation

The headphone controls operational mode. System enters SE mode when headphone jack is empty.
When a set of headphone plugged into the jack, the system switched to BTL mode.

IR Controller

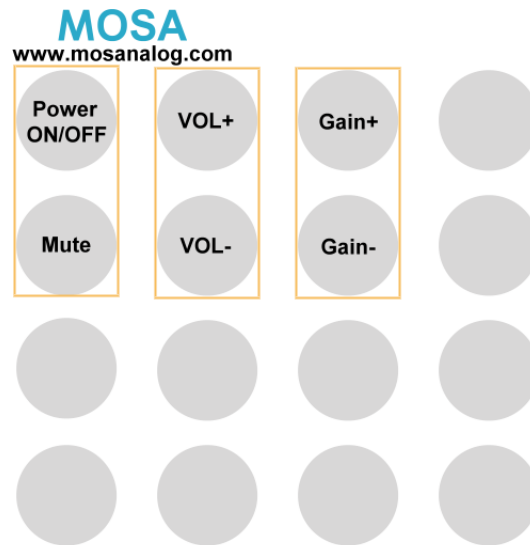

MS6864

1 Stereo inputs / 2W PA output
integrated Volume Control

Power ON/OFF : The power key.

Press the key once to set power-on or power-off for MS6864.

The default values are GAIN 0dB, ATTENUATION -20dB and MUTE-ON.

VOL+, VOL- : The volume control keys.

The volume control in 1.25dB/step as the switch is pressed once, the range is -77.5dB to 0dB.

Gain+, Gain- : The gain control keys.

The gain control in 3dB/step as the switch is pressed once, the range is 0dB to 21dB.

Mute : The mute key

Press the key once to set mute-on or mute-off.

PD/Active : The power down key.

Press the key once to set power-down or activation for MS6864.

Circuit

