

## MS7212-A2 Hermetic Pressure Sensor Die (0-12 bar)



- 0 to 1200 kPa range (12 bar or 174 PSI)
- Absolute pressure sensor
- Hermetic sensor, temperature up to 150 °C
- Pads on one side
- For harsh environment
- RoHS-compatible & Pb-free<sup>1</sup>

### DESCRIPTION

The MS7212-A2 is an absolute silicon micro-machined pressure sensor for harsh environment, with the pads on one side. A vacuum reference cavity is sealed on top of the sensitive silicon membrane by the anodic bonding of a glass cap. The pressure, applied on the backside, is converted in electrical signal by piezo-resistors implanted in the silicon membrane. To improve the sensor stability, a drilled glass is bonded on the backside. As the pressure port consists of glass and silicon, both stable in most of the chemicals, the MS7212-A2 is suitable for media-resistive applications.

### FEATURES

- Media resistive pressure sensor die
- Output Span 150 mV @ 5 V
- Temperature Range -40 °C ... + 150 °C
- Linearity 0.05 % (typical)
- Die size 1.73 x 1.18 mm<sup>2</sup>
- Low Cost, High reliability

### APPLICATIONS

- Harsh environments
- Absolute pressure sensor systems
- Braking systems
- Tire pressure
- Engine controls
- Oil pressure

### ELECTRICAL CONNECTIONS

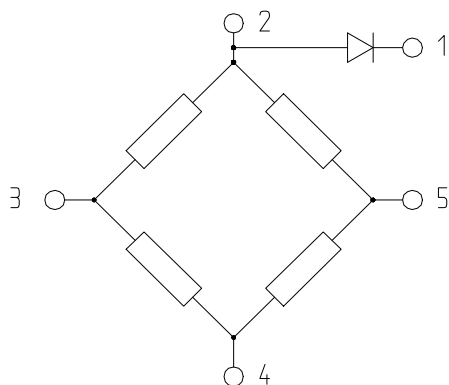

Pin	Symbol	Description
1	EPI / I diode (-)	Epi contact / Cathode of diode (n)
2	Vs+ / I diode (+)	Supply voltage / Anode of diode (p)
3	Out+	Positive output*
4	GND	Ground
5	Out-	Negative output*

\*Positive output for pressure applied backside

<sup>1</sup> The European RoHS directive 2002/95/EC (Restriction of the use of certain Hazardous Substances in electrical and electronic equipment) bans the use of lead, mercury, cadmium, hexavalent chromium and polybrominated biphenyls (PBB) or polybrominated diphenyl ethers (PBDE).

# MS7212-A2 Hermetic Pressure Sensor Die (0-12 bar)

## BOND PAD CONFIGURATION

### Important remarks:

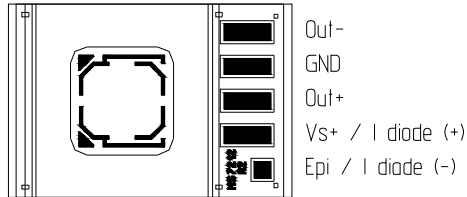

The epitaxial layer is not connected to the Vs+ pin on the die; this is to allow temperature measurement with the diode. The epi contact and the cathode of the diode have the same electrical potential. To avoid bias effects, diode and bridge cannot be used simultaneously.

As the sensing elements are diffused resistances, the voltage applied on the ground pads (GND) and on the supply voltage (Vs+) have to be lower or equal than the voltage applied on the epi contact (EPI). For better stability it is good to define the potential of the EPI.

Gold ball bonding or aluminum wedge bonding can be used to wire-bond the sensor. The quality of the wire-bonding is equipment and process dependant. For this reason, it is strongly recommended that a thorough wire-bonding qualification is made by the end user if the sensor is going to be operated over an extended temperature range.

## LAYOUT

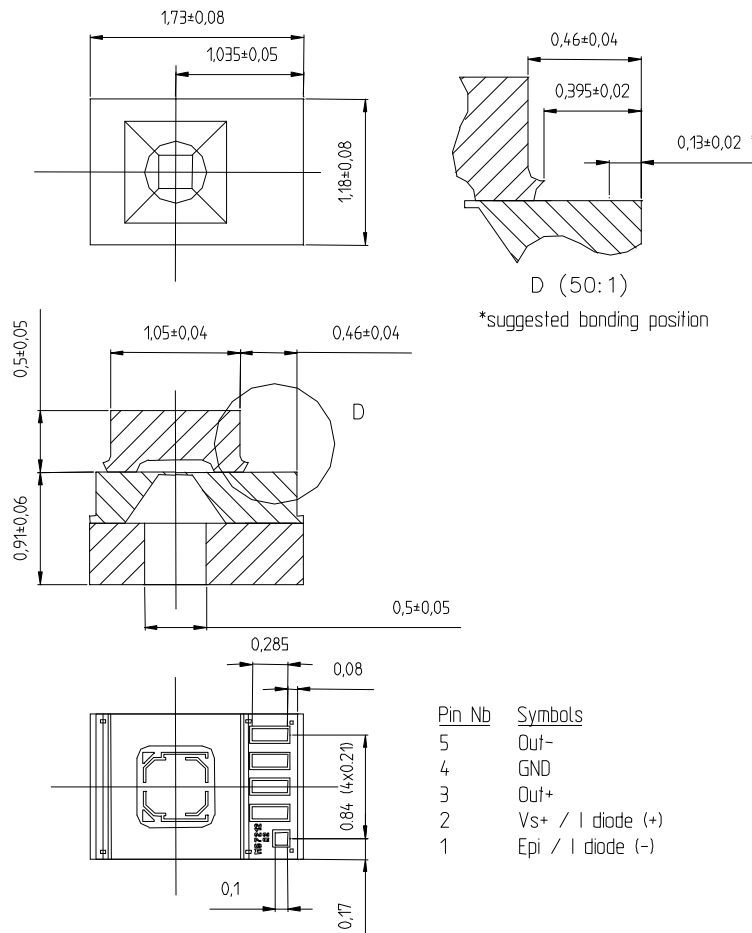

\*suggested bonding position

Pin. Nb	Symbols
5	Out-
4	GND
3	Out+
2	Vs+ / I diode (+)
1	Epi / I diode (-)

Bond Pads: Aluminium, 100 um in width  
Cavity depth: 100 um

## MS7212-A2 Hermetic Pressure Sensor Die (0-12 bar)

### FULL SCALE PRESSURE

kPa	bar	mbar	PSI	atm	mm Hg	m H <sub>2</sub> O	Inches H <sub>2</sub> O
1200	12	12000	174	11.8	9001	122	4818

### ABSOLUTE MAXIMUM RATINGS

Parameter	Symbol	Conditions	Min	Max	Unit
Supply voltage	V <sub>s+</sub>	T <sub>a</sub> = 25 °C		20	V
Supply current diode	I diode (+)			100	μA
Storage temperature	T <sub>s</sub>		-40	+150	°C
Pressure overload				60	bar

### ELECTRICAL CHARACTERISTICS

(Reference conditions: Supply voltage V<sub>s+</sub> = 5 Vdc; Ambient Temperature T<sub>a</sub> = 25 °C)

Parameter	Min	Typ	Max	Unit	Notes
Operating Pressure Range	0		12	bar	
Operating Temperature Range	-40		150	°C	
Bridge Resistance	3.0	3.4	3.8	kΩ	
Full-scale span (FS)	120	150	180	mV	
Zero Pressure Offset	-40	0	40	mV	
Linearity		± 0.05	± 0.15	% FS	1
					2
Temperature Coefficient of Resistance	+2400	+ 2800	+ 3300	ppm/°C	3
Span	-1500	- 1900	- 2300	ppm/°C	
Offset	-80		+ 80	μV/°C	
Diode		-2.2		mV/°C	2
Pressure Hysteresis		± 0.05	± 0.15	% FS	4
Repeatability		± 0.05	± 0.15	% FS	5
Temperature Hysteresis			0.3	% FS	6

### NOTES

- 1) Deviation at one half full-scale pressure from the least squares best line fit over pressure range (0 to 12 bar).
- 2) The forward voltage of the diode is measured when driving it with a typical value of 40 μA.
- 3) Slope of the endpoint straight line from 25 °C to 60 °C.
- 4) Output deviation at any pressure within the specified range, when this pressure is cycled to and from the minimum or maximum rated pressure, at 25 °C.
- 5) Same as 3) after 10 pressure cycles.
- 6) Maximum difference in offset after one thermal cycle from -40 °C to +150 °C.

### TEMPERATURE COMPENSATION

The diode between the piezo diffusion and the epi contact can be used for temperature measurement. The forward voltage of the diode is measured on I diode (-) when a typical current of 40 μA fed in I diode (+). Temperature measurement cannot be done at the same time as pressure sensing due to bias effects.

## MS7212-A2 Hermetic Pressure Sensor Die (0-12 bar)

### PICKING TOOLS

The MS7212-A2 sensors have a topside glass cap ( $1.05 \times 1.18 \text{ mm}^2$ ) and a backside glass ( $1.73 \times 1.18 \text{ mm}^2$ ). The pick and place tool has to be of a soft material as rubber (Hardness 78-97 Shore A). Its external size must fit the Pyrex™ cap. Successful tests were done with some tools of SPT (see SPT drawing and references below).

SPT references	RTR-A2-045x045
External dimension	TL & TW: 0.045 inch / 1.14 mm
Internal dimensions	ØH: 0.025 inch / 0.63 mm

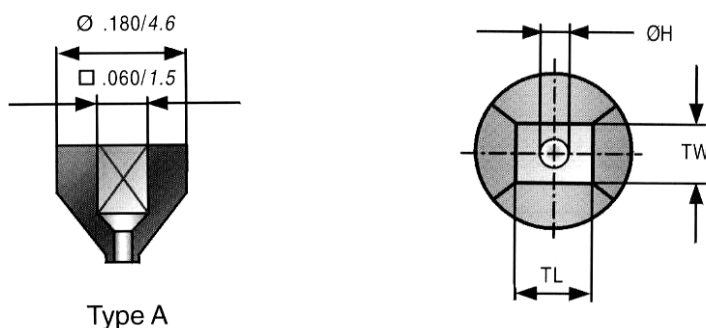

### WIRE BONDING

The bondable area is  $100 \times 100 \mu\text{m}^2$  for the EPI pad and  $100 \times 285 \mu\text{m}^2$  for the other pads. The location of the bonding pads is close to the top Pyrex glass edge reducing the possible size and angle of the bonding capillary. Refer to the detail view *D* on the layout for more precision.

### ORDERING INFORMATION

Product code	Type	Product	Art.-Nr.
MS7212-A2	Absolute	12 bar pressure sensor die for harsh environment sawn on b/f	721225023

The MS7212-A2 dice are supplied sawn on blue foil, mounted on plastic rings.

**MS7212-A2 Hermetic Pressure Sensor Die (0-12 bar)****FACTORY CONTACTS****NORTH AMERICA**

Measurement Specialties, Inc.  
1000 Lucas Way  
Hampton, VA 23666

Tel: +1 800 555 1551  
Fax: +1 757 766 4297  
e-mail: [sales@meas-spec.com](mailto:sales@meas-spec.com)  
Website: [www.meas-spec.com](http://www.meas-spec.com)

**EUROPE**

MEAS Switzerland SA  
Ch. Chapons-des-Prés 11  
CH-2022 Bevaix

Tel: +41 32 847 9550  
Fax: + 41 32 847 9569  
e-mail: [sales.ch@meas-spec.com](mailto:sales.ch@meas-spec.com)  
Website: [www.meas-spec.com](http://www.meas-spec.com)

**ASIA**

Measurement Specialties (China), Ltd.  
No. 26 Langshan Road  
Shenzhen High-Tech Park (North)  
Nanshan District, Shenzhen, 518107  
China

Tel: +86 755 8330 1004  
Fax: +86 755 8330 6797  
e-mail: [pfc.cs.asia@meas-spec.com](mailto:pfc.cs.asia@meas-spec.com)  
Website: [www.meas-spec.com](http://www.meas-spec.com)

The information in this sheet has been carefully reviewed and is believed to be accurate; however, no responsibility is assumed for inaccuracies. Furthermore, this information does not convey to the purchaser of such devices any license under the patent rights to the manufacturer. Measurement Specialties, Inc. reserves the right to make changes without further notice to any product herein. Measurement Specialties, Inc. makes no warranty, representation or guarantee regarding the suitability of its product for any particular purpose, nor does Measurement Specialties, Inc. assume any liability arising out of the application or use of any product or circuit and specifically disclaims any and all liability, including without limitation consequential or incidental damages. Typical parameters can and do vary in different applications. All operating parameters must be validated for each customer application by customer's technical experts. Measurement Specialties, Inc. does not convey any license under its patent rights nor the rights of others.