

## HD/FHD Selectable Video Filter Driver And Video Coaxial Control Decoder

### PRODUCT DESCRIPTION

The MS7338MA integrated a bandwidth selectable video amplifier and video coaxial control decoder. The video amplifier integrates Single rail-to-rail output driver with 12dB Gain and 10th order reconstruction filter, which also can select 30MHz/45MHz -3dB bandwidth. The video coaxial control decoder integrated a high-speed processor, effective separation for mixed-signal. MS7338MA provides improved image quality compared with passive LC filters and discrete drivers solution. Operating from single supplies ranging from +2.7V to +5V and sinking an ultra-low 35mA quiescent current, the MS7338MA is ideally suited for battery powered applications.

The MS7338MA has lead MSOP-8 package, and ESD (HBM) reaches over 3KV.

### FEATURES

- 30MHz/45MHz -3dB selectable 10th order filter
- Transparent input clamping
- 12dB output driver Gain and drive dual video load
- Rail-to-Rail Output
- Input Voltage Range Includes Ground
- AC or DC Coupled Inputs
- AC or DC Coupled Outputs
- Operates from 2.7V to 5V Single power supply
- Low Power 35mA Supply Current
- Lead MSOP-8 package
- Through the AEC\_Q100 authentication

### APPLICATIONS

- Video On Demand (VOD)
- Communications device
- Portable and handheld product
- AHD/TVI/CVI video driver and reverse control decoder

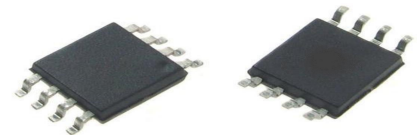

**MSOP-8**

### PACKAGE/ORDERING INFORMATION

Part Number	Package	Marking
MS7338MA	MSOP-8	7338MA

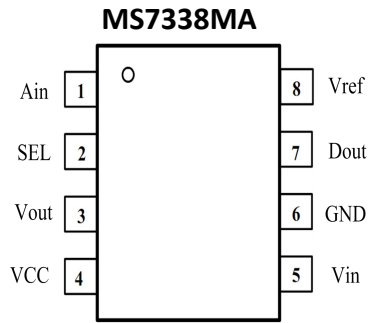
**PIN CONFIGURATIONS**
**Pin Description of Fig1**

**Figure1.MSOP-8**

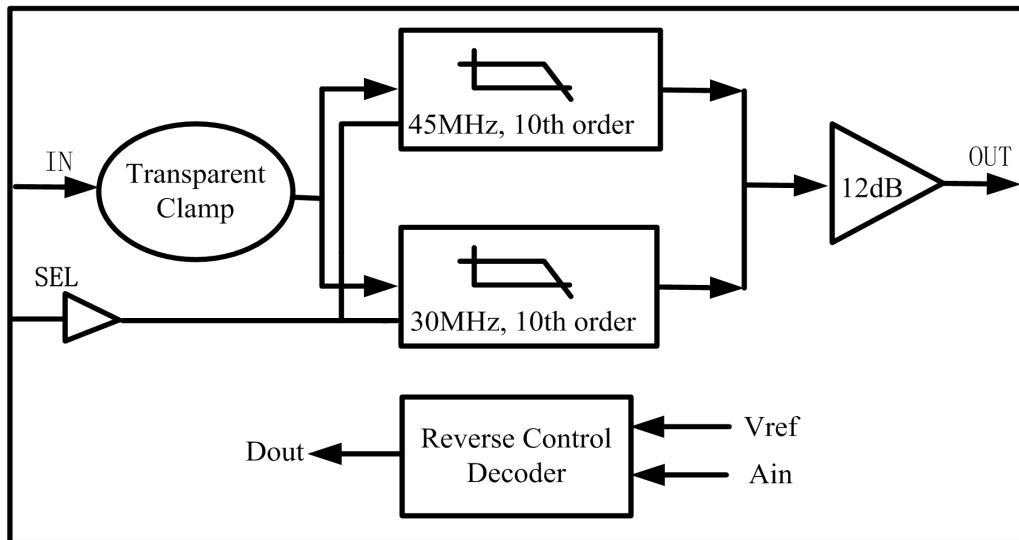
Pin	Name	Function Description
1	Ain	Comparator input
2	SEL	SEL is low: FHD(45MHz) SEL is high: HD(30MHz) SEL is float: HD(30MHz)
3	Vout	Video output
4	VCC	Power supply
5	Vin	Video input
6	GND	Ground
7	Dout	Reverse control output
8	Vref	Internal reference

**BLOCK DIAGRAM**

**ABSOLUTE MAXIMUM RATINGS**

Stresses below those listed under Absolute Maximum Ratings may cause permanent damage to the device. This is a stress rating only; functional operation of the device at these or any other conditions below those indicated in the operational section of this specification is not implied. Exposure to absolute maximum rating conditions for extended periods may affect device reliability.

PARAMETER	MAXIMUM
Supply Voltage, V+ to V-	6V
Input Voltage	GND-0.3V to (+VS)+0.3V
Storage Temperature Range	-65°C to +150°C
Junction Temperature	160°C
Operating Temperature Range	-40°C to +125°C
Power Dissipation, PD @ TA = 25°C	0.8W
Package Thermal Resistance, $\theta_{JA}$	128°C/W
Lead Temperature Range (Soldering 10 sec)	260°C
ESD Susceptibility (HBM)	>3000V
MM	>300V

**Electrical Characteristics(3.3V)**

(VCC=3.3V, TA = 25°C, unless otherwise noted.)

**Operational amplifier channel:**

Parameter	Symbol	Conditions	Min	Typ	Max	Unit	
Voltage Gain	Av	Vpp=0.5V, RL=150Ω		12.4		dB	
-1dB Bandwidth	HD	RL=150Ω		22		MHz	
	FHD			18			
-3dB Bandwidth	HD	RL=150Ω		30		MHz	
	FHD			45			
Stop-Band Rejection	HD	f=60MHz, RL=150Ω		32		dB	
	FHD	f=100MHz, RL=150Ω		27			
Slew Rate	HD	Vin=0.5V step, 20%-80%, f=100k, RL=150Ω		83		V/us	
	FHD			98			
Group Delay	HD	F=400kHz		29		ns	
	FHD			20			
Rise Time	HD	Vout=2Vp-p, 80%-20%		14.3		ns	
	FHD			12.2			
Fall Time	HD				9.9		ns
	FHD				6.4		
Output Voltage Swing		Vin=3V, RL=150Ω		3.14		V	
Output Short-Circuit Current	Isc	Vin=0.1V, 10Ω to VDD		147		mA	
Output Level Shift Voltage		Vin=0V, no load		560		mV	

**video coaxial control decoding channel:**

Parameter	Symbol	Conditions	Min	Typ	Max	Unit
Transmission Delay		F=100k,Vpp=1V,REF=1V,rising edge		30		ns
		F=100k,Vpp=1V,REF=1V,trailing edge		17.3		
		F=1M,Vpp=1V,REF=1V,rising edge		22		
		F=1M,Vpp=1V,REF=1V,trailing edge		17.8		
Dout Output High	V <sub>OH</sub>	R <sub>L</sub> =1K		3.09		V
Dout Output Low	V <sub>OL</sub>	R <sub>L</sub> =1K		6		mV
Dout Sensitivity		REF=0.5V, V <sub>DOUT</sub> from 0 to 1		0.7		V
		REF=0.5V, V <sub>DOUT</sub> from 1 to 0		0		
		REF=1.5V, V <sub>DOUT</sub> from 0 to 1		1.5		
		REF=1.5V, V <sub>DOUT</sub> from 1 to 0		1.21		
Bandwidth		No load, Vpp=1V, REF=1V duty cycle<55%		5.5		MHz

**Supply Voltage:**

Parameter	Symbol	Conditions	Min	Typ	Max	Unit
Voltage operating range		Vin=1M, Vpp=0.5V, R <sub>L</sub> =150Ω	2.5		5.5	V
Power Supply Rejection Ration	PSRR	V <sub>S</sub> =+2.7V to 5.5V	52	60	63	dB
Supply current	I <sub>SY</sub>	No input, No load		16		mA

**Electrical Characteristics(5V)**

(VCC=5V, TA = 25°C, unless otherwise noted.)

**Operational amplifier channel:**

Parameter	Symbol	Conditions	Min	Typ	Max	Unit	
Voltage Gain	Av	Vpp=0.5V, RL=150Ω		12.7		dB	
-1dB Bandwidth	HD	RL=150Ω		21		MHz	
	FHD			20			
-3dB Bandwidth	HD	RL=150Ω		30		MHz	
	FHD			43			
Stop-Band Rejection	HD	f=60MHz, RL=150Ω		30		dB	
	FHD	f=100MHz, RL=150Ω		26			
Slew Rate	HD	Vin=0.5V step, 20%-80%, f=100k, RL=150Ω		93		V/us	
	FHD			113			
Group Delay	HD	F=400kHz		29		ns	
	FHD			20			
Rise Time	HD	Vout=2Vp-p, 80%-20%		12.8		ns	
	FHD			10.6			
Fall Time	HD				10.1		ns
	FHD				6.4		
Output Voltage Swing		Vin=3V, RL=150Ω		4.76		V	
Output Short-Circuit Current	Isc	Vin=0.1V, 10Ω to VDD		221		mA	
Output Level Shift Voltage		Vin=0V, no load		650		mV	

**video coaxial control decoding channel:**

Parameter	Symbol	Conditions	Min	Typ	Max	Unit
Transmission Delay		F=100k,Vpp=1V,REF=1V,rising edge		18.7		ns
		F=100k,Vpp=1V,REF=1V,trailing edge		17.5		
		F=1M,Vpp=1V,REF=1V,rising edge		19		
		F=1M,Vpp=1V,REF=1V,trailing edge		17.5		
Dout Output High	V <sub>OH</sub>	R <sub>L</sub> =1K		4.73		V
Dout Output Low	V <sub>OL</sub>	R <sub>L</sub> =1K		8		mV
Dout Sensitivity		REF=0.5V, V <sub>DOUT</sub> from 0 to 1		0.9		V
		REF=0.5V, V <sub>DOUT</sub> from 1 to 0		0.43		
		REF=1.5V, V <sub>DOUT</sub> from 0 to 1		1.52		
		REF=1.5V, V <sub>DOUT</sub> from 1 to 0		1.23		
Bandwidth		No load, Vpp=1V, REF=1V duty cycle<55%		4.8		MHz

**Supply Voltage:**

Parameter	Symbol	Conditions	Min	Typ	Max	Unit
Voltage operating range		Vin=1M, Vpp=0.5V, R <sub>L</sub> =150Ω	2.5		5.5	V
Power Supply Rejection Ration	PSRR	V <sub>S</sub> =+2.7V to 5.5V	52	60	63	dB
Supply current	I <sub>SV</sub>	Vin=1M, Vpp=0.5V, REF=0.5V, R <sub>L</sub> =150Ω		35		mA

## APPLICATIONS INFORMATION

### Functional Description

MS7338MA operates from a single +2.7V to +5V supply. In application, MS7338MA is a fully integrated solution for filtering and buffering HDTV signals in front of video decoder or behind video encoder, and reverse control decoder. MS7338MA's solution can help you save PCB size and production cost, it also improves video signal performance comparing with traditional design using discrete components. MS7338MA features a DC-coupled input buffer, 10th low-pass filter to eliminate out-of-band noise of video encoder, and a gain of +12dB in the output amplifier to drive 75Ω load. The AC or DC-coupled input buffer eliminates sync crush, droop, and field tilt. The output of MS7338MA also can be DC-coupled or AC-coupled.

### Power-Supply Bypassing and Layout

Correct power supply bypassing is very important for optimizing video performance in design. both 0.1μF ceramic and 10μF electrolytic capacitors are always used to Bypass VCC pin of MS7338MA, please place these two capacitors as close to the MS7338MA output pin as possible, a large ground plane is also needed to ensure optimum performance. The input and output termination resistors should be placed as close to the related pin of MS7338MA as possible to avoid performance degradation. The PCB traces at the output side should have 75Ω characteristic impedance in order to match the 75Ω characteristic impedance cable connecting external load. In design, please keep the board trace at the inputs and outputs of the MS7338MA as short as possible to minimize the parasitic stray capacitance and noise pickup.

0.1uF capacitor is used to stabilize Vref pin of MS7338MA.

### Different Bandwidth To Choose

The SEL pin of MS7338MA can select 30MHz/45MHz -3dB bandwidth. SEL is high select 30MHz, SEL is low select 45MHz.

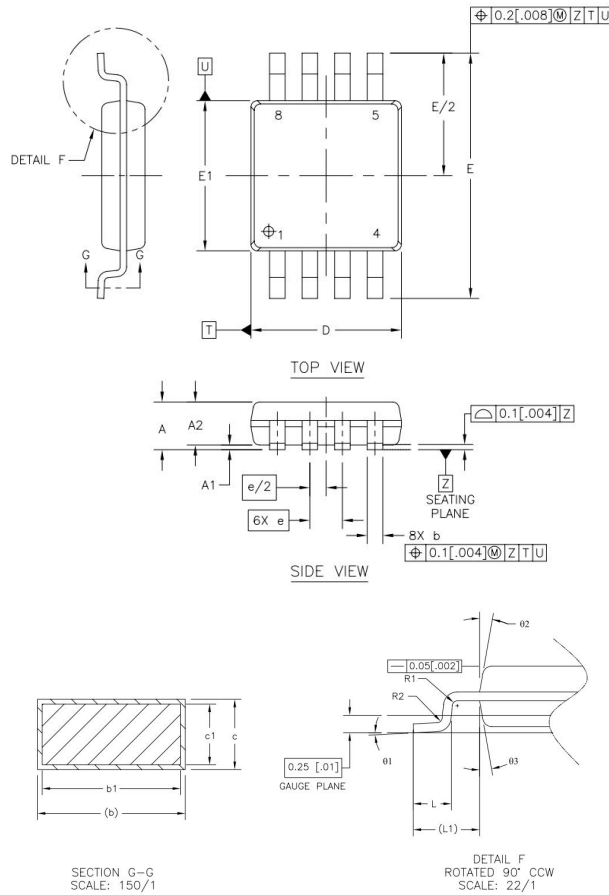

**PACKAGE OUTLINE DIMENSIONS**
**MSOP8:**

DESCRIPTION	Symbol	Dimensions In Millimeters			Dimensions in Inches			
		MIN	NOM	MAX	MIN	NOM	MAX	
TOTAL THICKNESS	A	0.86		1.04	0.034		0.041	
STAND OFF	A1	0.05		0.13	0.002		0.005	
MOLD THICKNESS	A2	0.81		0.91	0.032		0.036	
LEAD WIDTH(PLATING)	b	0.28		0.38	0.011		0.015	
LEAD WIDTH	b1	0.25		0.33	0.010		0.013	
L/F THICKNESS(PLATING)	c	0.13		0.2	0.005		0.008	
L/F THICKNESS	c1	0.08		0.18	0.003		0.007	
BODY SIZE	X	D	2.9	3	3.1	0.114	0.118	0.122
	Y	E1	2.9	3	3.1	0.114	0.118	0.122
		E	4.8	4.9	5	0.189	0.193	0.197
LAED PITCH	e	0.65 BSC			0.026 BSC			
	L	0.445	0.546	0.648	0.017	0.021	0.026	
FOOTPRINT	L1	0.95 REF			0.037 REF			
	$\theta 1$	0°		6°	0°		6°	
	$\theta 2$	5°		15°	5°		15°	
	$\theta 3$	5°		15°	5°		15°	
	R1	0.07		----	0.003		----	
	R2	0.07		----	0.003		----	

## Marking and Packaging Specifications

### 1、Marking drawing description

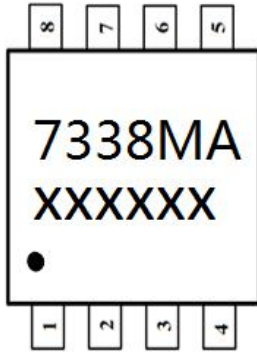

7338MA: product name

XXXXXX: Product code

### 2、Marking drawing pattern

Laser printing, contents in the middle, font type Arial.

### 3、Packaging Specifications

Device	Package	piece/reel	reel/box	piece /box	box/carton	piece/carton
MS7338MA	MSOP8	3000	1	3000	8	24000



MOS circuit operation precautions:

Static electricity can be generated in many places. The following precautions can be taken to effectively prevent the damage of MOS circuit caused by electrostatic discharge:

- 1,The operator shall ground through the anti-static wristband.
- 2,The equipment shell must be grounded.
- 3,The tools used in the assembly process must be grounded.
- 4,must be used conductor packaging or antistatic materials packaging or transportation.



+86-571-89966911



Rm701, No.9Building, No. 1WeiYe Road, Puyan Street, Binjiang District, Hangzhou,  
Zhejiang



[http:// www.relmon.com](http://www.relmon.com)