

MS8000 – DATASHEET

Single axis analog accelerometer

The MS8000 product is a single axis MEMS capacitive accelerometer based on a bulk micro-machined silicon element designed for high stability. The product is low power, fully calibrated, robust and extremely stable and the electronic configuration provides a solid power on reset and ensures a full protection against brown-out. It operates from a single power supply voltage (between +2.5V and +5.5V) with low current consumption (< 0.5mA at 5V). The output is a ratiometric analog voltage that varies between +0.5V and +4.5V for the full-scale acceleration range at a voltage supply of +5V. The sensor is fully self-contained and packaged in a 48-pin LCC ceramic housing, thus insuring a full hermeticity.



Features

- $\pm 2g$ to $\pm 100g$ range
- Excellent bias stability (less than 0.05% of full scale)
- Single power supply (+2.5V to +5.5V, ratiometric voltage output)
- Low power
- Small 48 pin LCC ceramic package with hermetic sealing (14.2mm x 14.2mm)
- Individually calibrated (bias, scale factor and non-linearity)
- Demonstrated high reliability
- RoHS compliant suitable for lead free soldering process and SMD mounting

Accelerometer specifications

All values are specified at +20°C (+68°F) and 5.0 VDC supply voltage, unless otherwise stated

Parameters	MS8002.D	MS8010.D	MS8030.D	MS8100.D	Units
Full scale range	$\pm 2g$	$\pm 10g$	$\pm 30g$	$\pm 100g$	g
Bias calibration	< 10	< 50	< 150	< 500	mg
One year bias stability @ 6000g [1]	1.5 (< 5)	7.5 (< 25)	22 (< 75)	75 (< 250)	mg typ. (max.)
Switch on/off repeatability	< 0.15	< 0.75	< 1.5	< 7.5	mg max.
Bias temp. coefficient [2]	< 0.1	< 0.5	< 1.5	< 5	mg/°C typ.
	± 0.4	± 2	± 6	± 20	mg/°C max.
Scale factor sensitivity (K1)	1000 \pm 8	200 \pm 2	66.6 \pm 1	20 \pm 1	mV/g
One year scale factor stability [1]	300 (< 1000)	300 (< 1000)	300 (< 1000)	300 (< 1000)	ppm typ. (max.)
Scale factor temp. coefficient [2]	100	100	100	100	ppm / °C typ.
	-50 / 250	-50 / 250	-50 / 250	-50 / 250	min. / max.
Input axis misalignment (Kp, Ko)	< 10	< 10	< 10	< 10	mrad max.
	1	1	1	1	% max.
Resolution / Threshold (@ 1Hz)	< 0.1	< 0.6	< 1.7	< 5.5	mg max.
Non linearity	< 0.8	< 0.9	< 0.9	< 1	% of FS max.
	< 0.02	< 0.09	< 0.27	< 1	g max.
Bandwidth [3]	0 to \geq 200	0 to \geq 200	0 to \geq 100	0 to \geq 200	Hz
Noise spectral density in band	18	18	18	18	$\mu V/\sqrt{Hz}$ typ.
(0 ; 9kHz)	24	24	24	24	max.
Resonant frequency	1.4	3.7	6.3	15	kHz

[1] See Glossary

[2] See Glossary

[3] The bandwidth is defined as the frequency band for which the sensitivity has decreased by less than 3dB.

Environmental specifications

Parameters	MS8002.D	MS8010.D	MS8030.D	MS8100.D
Operating temperature range	-55°C to +125°C (-67°F to 255°F)			
Reliability	Results based on MIL-HDBK-217, notice 2, are available on request.			
Shock resistance	Up to 6'000 g (0.15ms half-sine, single shock, not repetitive, in one direction o, p or i)			
Recovery time	< 1ms (1000g, half-sine period 1ms, shocks in direction i)			
Vibration	20 g rms, 20-2000 Hz (random noise, 30 minutes in each direction o, p, i)			
ESD sensitivity	Class 2 (requirements MIL-STD-883-G, 1 Method 3015.7), Human Body Model 2kV			
Ultrasonic cleaning	The product can't be cleaned with ultrasonic bath. Such a cleaning process will largely affect the sensor integrity			

Packaging

The packaging is a standard LCC ceramic housing with a total of 48 pins. The precise dimensions are given in the next figure and the weight of the final product is typically smaller than 1.64 grams

The sealing process is qualified according to the MIL-STD-883-G and systematical leak tests are performed up to $5 \cdot 10^{-8}$ atm·cm³/s.

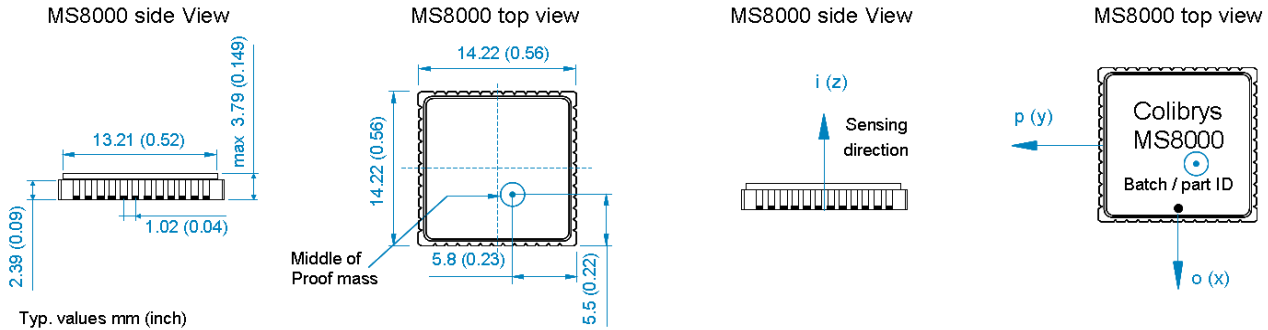

SMD Mounting

The MS8000 is RoHS compliant suitable for lead free soldering process and SMD mounting. It must be tightly fixed to the PCB, using the bottom of the housing as reference plane to ensure a good axis alignment. The stress induced by the soldering of the LCC package is a specific MEMS concern, especially when it comes to high-end capacitive sensors. In order to obtain good stress homogeneity and the best long term stability, all the leads of the accelerometer must be soldered to the pads of the PCB. See the Safran Colibrys Application Note "LCC-48 housing, soldering conditions" available on our web site for more information about the LCC mounting process in general.

The degolding process applied to the products is excluded from Safran Colibrys recommendations. And if applied it cancels any products warranty and liability.

Physical specifications

Parameters	MS8002.D	MS8010.D	MS8030.D	MS8100.D
Packaging	Non magnetic, LCC, 48 pin housing			
Lead finishing	Au plating: 0.5 to 1.5 µm Ni plating: 1.27 to 8.89 µm (typ. 3 to 5 µm) W (tungsten): 10 to 15 µm			
Hermeticity	The product has been qualified according to MIL-STD-883-G. Hermetic sealing is systematically qualified at $5 \cdot 10^{-8}$ atm·cm ³ /s			
Weight	< 1.64 grams			
Size	Typ. 14.2 x 14.2 x 3.3 mm (0.56 x 0.56 x 0.13 inch) Max. 14.48 x 14.48 x 3.79 mm (0.57 x 0.57 x 0.149 inch)			
Proximity effect	The sensor is sensitive to external parasitic capacitance. Moving metallic objects with large mass or parasitic effect at proximity of the accelerometer (mm range) must be avoided to insure best product performances.			
Reference plane for axis alignment	LCC must be tightly fixed to the PCB, using the bottom of the housing as reference plane for axis alignment. Using the lid as reference plane or for assembly may affect specifications and product reliability (i.e. axis alignment and/or lid soldering integrity)			

Principle of operation

The standard calibration voltage for the MS8000.D is (VDD-VSS) = 5V. Therefore, all specifications are valid for this supply voltage unless otherwise stated. Upon market request, the calibration of the product at a different voltage (between 2.5V and 5.5V) is possible. In such a case, the nominal output signal will vary according to the following equation:

$$V_{out} = (VDD - VSS) / 2 + A_i \cdot (K1 \cdot VDD / 5) \quad (1)$$

$$V_{AGND} = (VDD - VSS) / 2 \quad (2)$$

According to this equation (1), the bias and scale factor are ratiometric to the power supply voltage. A reference voltage VAGND is also provided at half of the power supply and corresponds to the output voltage at zero g. All sensors are calibrated to match the ideal response curve in term of offset, gain and non-linearity.

At every power-up, the microcontroller, used as memory, transfers the calibration parameters to the ASIC and then goes in a sleep mode. During this initialization phase, which takes less than 50ms, the current consumption goes up to max. 1,5mA @ 5V and at room temperature. Then, the normal operating current is set and remains less than 400µA under similar conditions.

The following model describes each sensor:

$$V_{out} = k_1 \cdot (k_0 + A_i + k_2 A_i^2 + k_3 A_i^3 + k_p A_p + k_o A_o + k_{ip} A_i A_p + k_{io} A_i A_o + E)$$

where

- A_i, A_p, A_o are the accelerations for each axes of the sensor with:
 l : input axis (z axis)
 p: pendulous axis (y axis)
 o: output axis, also named pivot or hinge axis (x axis)
- $K1$ is accelerometer scale factor [V/g]
- $K0$ is bias [g]
- $K2$ is second order non linearity [g/g²]
- $K3$ is third order non-linearity [g/g³]
- Kp is pendulous cross axis non linearity [rad]
- Ko is output cross axis non linearity [rad]
- Kip, Kio are cross-coupling coefficients [rad/g]
- E is the residual noise [g]

Electrical specifications

Parameters	MS8002.D	MS8010.D	MS8030.D	MS8100.D
Input voltage (VDD – VSS)	2.5 to 5.5 VDC. The standard voltage for calibration is 5.0 VDC.			
Output voltage range	From 0.5 to 4.5 VDC @ 5.0 VDC input voltage (VDD/2 at 0g)			
Operating current consumption	< 400 µA @ 5.0 VDC			
Initialization & reset current consumption	Typ. 1500 µA @ 5.0 VDC during the initialization phase (less than 35 ms at room temperature)			
Reset	The sensor is Brown out protected. A reset occurs when the power supply jumps more than -0.46 V with a slope >380V/s or if the power supply drops below 2.2V. The recovery time is typ. 25 ms (max 35 ms)			
Output impedance / load	Min. 50 kΩ at Vout (pin 32) and VAGND (pin 38) Max. 50 pF at Vout (pin 32) and Max. 100 µF at VAGND (pin 38)			

Temperature sensor specifications

Output Voltage at 20°C	Typ: 1.632 V
Sensitivity	Typ: -11.77 mV/°C
Long term stability	Max -0.03°C to +0.09°C (1000h @ 150°C)
Accuracy	± 5°C (From -40°C to 125°C)

Electrical compensation

The MS8000 delivers an output signal without any internal temperature compensation. The intrinsic temperature coefficient is quite small but can be further improved through a calibration, using the temperature provided by the internal temperature sensor. Third order compensation is generally required for a coherent modeling of a MS8000.D.

Sensor connections and power supply requirements

The detailed block diagram is given in the next figure

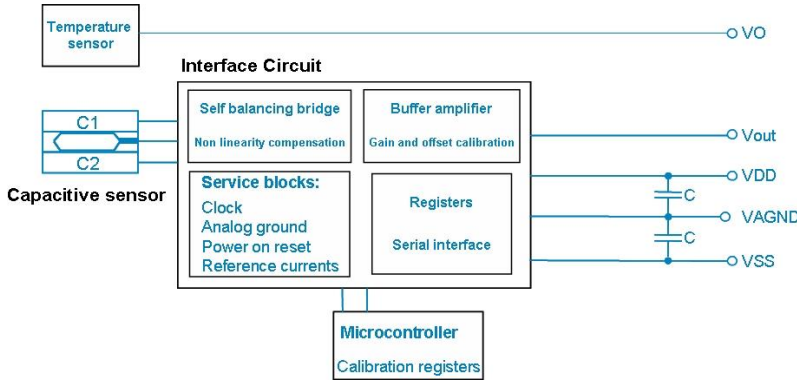

Components in the LCC48 packaging:

- 1-axis silicon MEMS sensor
- ASIC
- Microcontroller
- Temperature sensor
- Pull down resistor

It is strongly recommended to use decoupling capacitors [C] of 1µF each between VDD and VAGND and between VAGND and VSS, placed as close as possible from the accelerometer. COG or X7R @ 5% capacitor types are recommended. On top, the VAGND track should be as short as possible. Any other setup will potentially affect the bias calibration and stability.

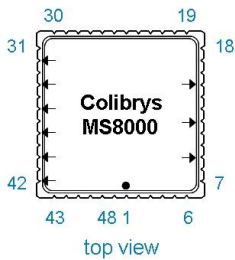

Pin	MS8000 Description	Notes
9	VPP (Safran Colibrys internal calibration pin)	Must be connected to VSS
12	SCK (Safran Colibrys internal calibration pin)	Must be connected to VSS
15	SDA (Safran Colibrys internal calibration pin)	Must be connected to VSS
32	Vout	Accelerometer output signal
36	VSS	Ground
38	VAGND	Accelerometer output reference voltage (VDD / 2)
40	VDD	Power supply
42	VO	Temperature sensor output

Glossary of parameters of the Data Sheet

g [m/s²]

Unit of acceleration, equal to standard value of the earth gravity (Accelerometer specifications and data supplied by Safran Colibrys use 9.80665 m/s²)

Bias [mg]

The accelerometer output at zero g

One Year Bias and Scale Factor Stability [mg /ppm]

Evolution of the Bias and Scale Factor values (K0 and K1) measured at sensor level mounted on sockets at 20°C after applying following tests:

- 100 times turn on / on,
- 72 h of storage at -55°C, unpowered
- and 10 days of storage +85°C unpowered,
- 10 times -40°C to 125°C Temperature cycling unpowered,
- 10 times -55°C to 85°C unpowered harass,
- vibration (20grms, random 20 to 2KHz) unpowered,
- single shock (6000g [1] or 1000g [2], 0.15ms) in one axis, unpowered

Bias temperature coefficient [μ g/°C]

Maximum variation of the bias calibration under variable external temperature conditions (slope of the best fit straight line through the curve of bias vs. temperature). Bias Temperature Coefficient is specified between -40°C and +20°C, where temperature behaviour is linear

Scale factor sensitivity [mV/g]

The ratio of the change in output (in volts) to a unit change of the input (in units of acceleration); thus given in mV/g

Scale factor temperature coefficient [ppm/°C]

Maximum deviation of the scale factor under variable external temperature conditions

Temperature sensitivity

Sensitivity of a given performance characteristic (typically scale factor, bias, or axis misalignment) to operating temperature, specified as worst case value over the full operating temperature range. Expressed as the change of the characteristic per degree of temperature change; a signed quantity, typically in ppm/°C for scale factor and g/°C for bias. This figure is useful for predicting maximum scale factor error with temperature, as a variable when modelling is not accomplished

Axis alignment [mrad]

The extent to which the accelerometer's true sensitive axis deviates from being perfectly orthogonal to the accelerometer's reference mounting surface when mounted to a flat surface

Resolution, Threshold [mg]

Value of the smallest acceleration that can be significantly measured

Non-linearity [% of FS]

The maximum deviation of accelerometer output from the best linear fit over the full operating range. The deviation is expressed as a percentage of the full-scale output (+AFS).

Bandwidth [Hz]

Frequency range from DC to F-3dB where the variation of the frequency response is less than -3dB or -5% for vibration sensors

Resonant frequency nominal [kHz]

Typical value of the resonant frequency of the mounted system

Noise [μ V/ \sqrt Hz]

Undesired perturbations in the accelerometer output signal, which are generally uncorrelated with desired or anticipated input accelerations

Quality

Safran Colibrys is ISO 9001:2015, ISO 14001:2015 and OHSAS 18001:2007 certified



Safran Colibrys is compliant with the European Community Regulation on chemicals and their safe use (EC 1907/2006) REACH.



MS8000 products comply with the EU-RoHS directive 2011/65/EC (Restrictions on hazardous substances) regulations
Recycling : please use appropriate recycling process for electrical and electronic components (DEEE)



MS8000 products are compliant with the Swiss LSPro : 930.11 dedicated to the security of products

Note:

- MS8030 accelerometers are available for sales to professional only
- Les accéléromètres MS8000 ne sont disponibles à la vente que pour des clients professionnels
- Die Produkte der Serie MS8000 sind nur im Vertrieb für kommerzielle Kunden verfügbar
- Gli accelerometri MS8000 sono disponibili alla vendita soltanto per clienti professionisti

Safran Colibrys complies with due diligence requirements of Section 1502, Conflict Minerals Survey, of the US Dodd-Frank Wall Street Reform and Consumer Protection Act and follows latest standard EICC/GeSI templates for Conflict Minerals declaration



Disclaimer

Safran Colibrys reserves the right to make changes to products without any further notice.

Performance may vary from the specifications provided in Safran Colibrys' datasheet due to different applications and integration. Operating performance, including one year stability, must be validated for each customer application by customer's technical experts. The one year stability specification expressed in the datasheet is valid only in the defined environmental conditions (cf One year stability glossary), and the performance at system level remains the customer's responsibility.

Stress in excess of the environmental specifications in the datasheet can cause permanent damage to the device. Exposure to the maximum ratings for an extended period of time (especially Shocks) may degrade the performance and affect reliability.

USE OF THE PRODUCT IN ENVIRONMENTS EXCEEDING THE ENVIRONMENTAL SPECIFICATIONS SET FORTH IN THE DATASHEET WILL VOID ANY WARRANTY. SAFRAN COLIBRYS HEREBY EXPRESSLY DISCLAIMS ALL LIABILITY RELATED TO USE OF THE PRODUCT IN ENVIRONMENTS EXCEEDING THE ENVIRONMENTAL SPECIFICATIONS SET FORTH IN THE DATASHEET.