MSA4709A

Subscriber Line Interface Circuit

GENERAL DESCRIPTION

The MSA4709A is designed to provide BSH functions and to meet PABX transmission performance requirements.

This device provides two-wire to four-wire conversion function (Hybrid).

FEATURES

- B (Battery feed), S (Supervision), and H (Hybrid) functions integrated on chip.
- Design to meet Central Office and PABX quality transmission requirements.
- All transmission performance parameters can be externally programmable.
- Free from parasitic SCR's using dielectric isolation technology.
- Size and weight reduction over conventional approaches.
- Supply voltage selectable ($V_{BB} = -24\text{ V} / -48\text{ V}$).
- 1 channel built-in relay driver.
- Package:
30-pin plastic Shrink DIP (SDIP30-P-400-1.78) (Product name: MSA4709ASS)

BLOCK DIAGRAM

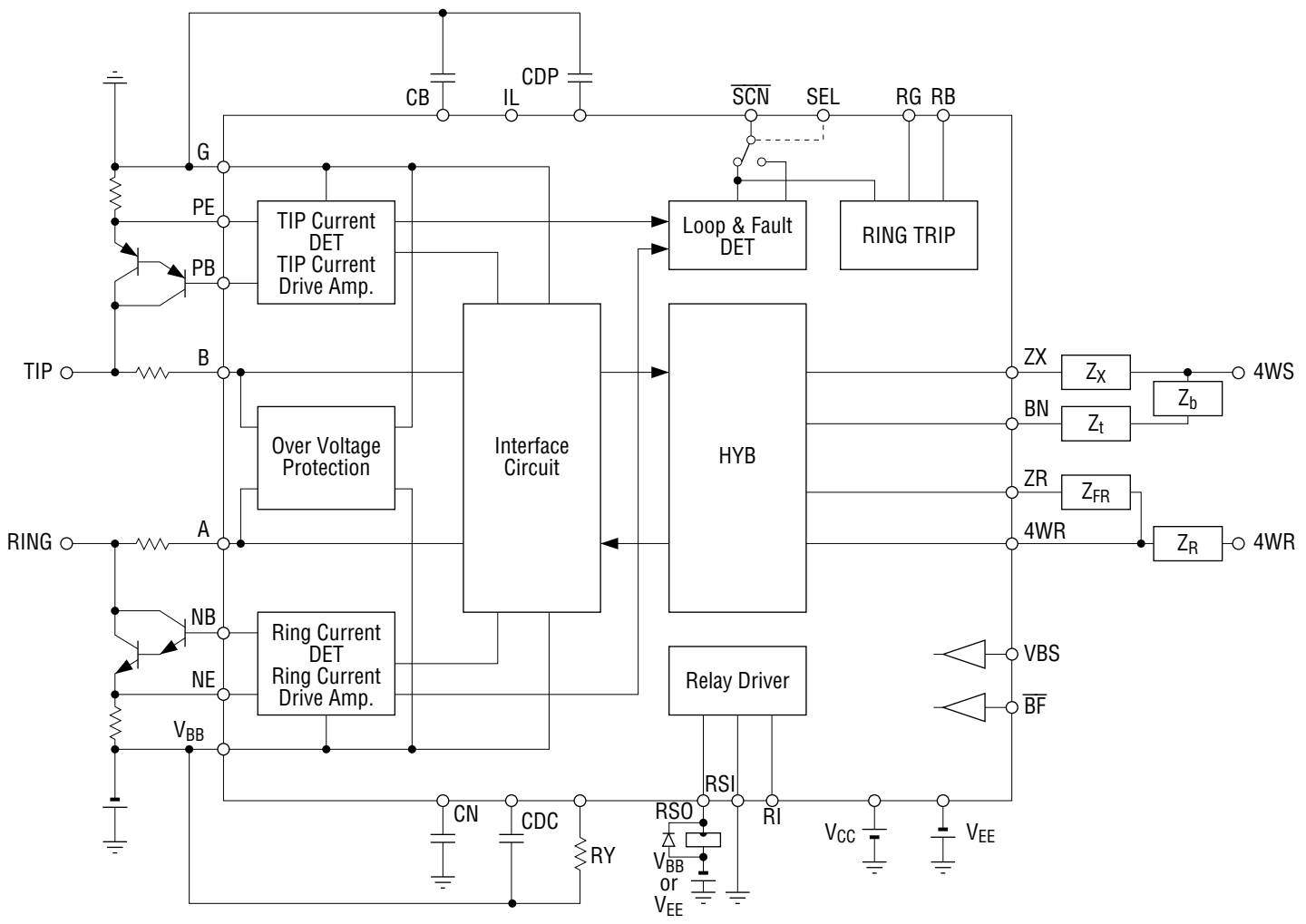

PIN CONFIGURATION (TOP VIEW)

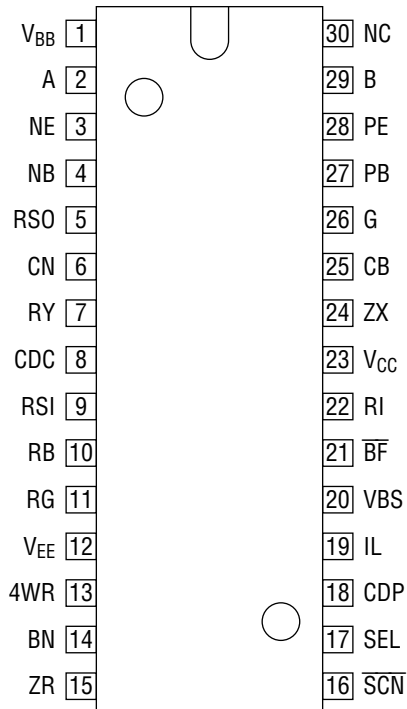

30-Pin Plastic Shrink DIP

Note: NC: No connect pin

PIN DESCRIPTION

Pin No.	Name	Description																					
1	V _{BB}	Battery supply, -48 V or -24 V input.																					
2	A	The Ring voltage sensing input. This input is high impedance (apr. 37 kΩ), and is connected to the built-in over voltage protection circuit.																					
3	NE	The Ring current sensing input is connected to the emitter of NPN Darlington transistor and the power resistor REA.																					
4	NB	The base drive output for the NPN Darlington transistor.																					
5	RSO	Relay driver current sink terminal.																					
6	CN	Battery noise rejection capacitor input. This capacitor value is 1 μF (60V).																					
7	RY	AC performance adjusting resistor RY input.																					
8	CDC	AC high impedance providing capacitor Cdc input and constant current feed at the short line adjusting zener diode input. This capacitor value is 1 μF (15V).																					
9	RSI	Relay driver current source terminal.																					
10	RB	Ring-Trip filtering capacitor input (RING).																					
11	RG	Ring-Trip filtering capacitor input (TIP).																					
12	V _{EE}	-5 V input.																					
13	4WR	Receive input and is connected to the negative input of the built-in buffer operational amplifier.																					
14	BN	Balancing network drive output.																					
15	ZR	Receive gain adjust and frequency compensation input.																					
16	SCN	Output of both the fault current detector and loop current detector. This output is open-collector with a built-in pull-up resistor. (apr. 10 kΩ). <table border="1" data-bbox="546 1078 1081 1340" style="margin-left: auto; margin-right: auto;"> <thead> <tr> <th>Condition</th> <th>SEL = "H"</th> <th>SEL = "L"</th> </tr> </thead> <tbody> <tr> <td>• ON-Hook</td> <td>H</td> <td>H</td> </tr> <tr> <td>• OFF-Hook</td> <td>L</td> <td>H</td> </tr> <tr> <td>• Dial pulse: break</td> <td>H</td> <td>H</td> </tr> <tr> <td>• Dial pulse: make</td> <td>L</td> <td>H</td> </tr> <tr> <td>• RING TRIP</td> <td>L</td> <td>H</td> </tr> <tr> <td>• Ground/Battery fault</td> <td>L</td> <td>L</td> </tr> </tbody> </table>	Condition	SEL = "H"	SEL = "L"	• ON-Hook	H	H	• OFF-Hook	L	H	• Dial pulse: break	H	H	• Dial pulse: make	L	H	• RING TRIP	L	H	• Ground/Battery fault	L	L
Condition	SEL = "H"	SEL = "L"																					
• ON-Hook	H	H																					
• OFF-Hook	L	H																					
• Dial pulse: break	H	H																					
• Dial pulse: make	L	H																					
• RING TRIP	L	H																					
• Ground/Battery fault	L	L																					

Pin No.	Name	Description
17	SEL	$\overline{\text{SCN}}$ output information select control input. At SEL = "L", $\overline{\text{SCN}}$ Indicates only ground/battery fault condition.
18	CDP	Dial pulse shaping capacitor input.
19	IL	Tip to Ring constant loop current determination resistor input.
20	VBS	Supply voltage selection terminal. $V_{\text{BS}} = V_{\text{CC}} (-24 \text{ V})$, $V_{\text{BS}} = \text{G} (-48 \text{ V})$.
21	$\overline{\text{BF}}$	Battery-feed mode control input. A logic level "H" switches off both the Ring and Tip current drive amp. and presents a high impedance to the line. (apr. 80 k Ω).
22	RI	Relay driver control input. RI = "H" is Driver "ON"
23	V _{CC}	+5 V input
24	ZX	2 wire terminating impedance component Z _x input. This pin has a low input impedance.
25	CB	Compensation capacitor input. This capacitor value is 4700 pF(35V).
26	G	Ground input.
27	PB	The base drive output for the PNP Darlington power transistor.
28	PE	The Tip current sensing input is connected to the emitter of the PNP Darlington power transistor and the power resistor REB.
29	B	The Tip voltage sensing input. This input is high impedance (apr. 37 k Ω) and is connected to the built-in over voltage protection circuit.
30	NC	No connection

ABSOLUTE MAXIMUM RATINGS

(Ta = 25°C)

Parameter	Symbol	Condition	Rating	Unit
Power Supply Voltage	V _{BB}	VBS = G	-53.0 to +0.3	V
		VBS = V _{CC}	-30.0 to +0.3	
	V _{CC}	—	-0.3 to +7.0	
	V _{EE}	—	-7.0 to +0.3	
Digital Input Voltage	V _{IN}	—	-0.3 to V _{CC} + 0.3	V
Relay Driver Current	I _{RD}	V _{RI} = H	-30	mA
Operating Temperature	T _{op}	—	0 to 80	°C
Storage Temperature	T _{STG}	—	-55 to 150	°C

RECOMMENDED OPERATING CONDITIONS

Parameter	Symbol	Condition	Min.	Typ.	Max.	Unit
Power Supply Voltage	V _{BB}	VBS = G	-53	-48	-43	V
		VBS = V _{CC}	-30	-24	-21.6	
	V _{CC}	—	+4.75	+5	+5.25	
	V _{EE}	—	-5.25	-5	-4.75	
Loop Resistance	R _L	V _{BB} = -48 V	0	—	2000	Ω
		V _{BB} = -24 V	0	—	600	
Operating Ambient Temperature	Ta	—	0	—	70	°C

ELECTRICAL CHARACTERISTICS

DC Characteristics

($I_L = 30\text{ mA}$, $V_{BB} = -24/-48\text{ V}$, $V_{CC} = 5\text{ V}$, $V_{EE} = -5\text{ V}$, $T_a = 25^\circ\text{C}$)

Parameter	Symbol	Condition	Min.	Typ.	Max.	Unit	
Power Supply Current	I_{BB}	$V_{BB} = -24\text{ V}$ ON-HOOK	—	1.7	2.6	mA	
	I_{CC}		—	4.0	6.0		
	I_{EE}		—	1	1.5		
	I_{BB}	$V_{BB} = -24\text{ V}$ OFF-HOOK	—	3.7	6.2		
	I_{CC}		—	5.4	8.1		
	I_{EE}		—	1.2	1.8		
	Power Supply Current	I_{BB}	$V_{BB} = -48\text{ V}$ ON-HOOK	—	1.5	2.3	mA
		I_{CC}		—	4.0	6.0	
		I_{EE}		—	1	1.5	
		I_{BB}	$V_{BB} = -48\text{ V}$ OFF-HOOK	—	5.0	7.5	
		I_{CC}		—	6.1	9.2	
		I_{EE}		—	1.2	1.8	
Power Dissipation	Pds24	$V_{BB} = -24\text{ V}$ ON-HOOK	—	70	100	mW	
	Pd24	$V_{BB} = -24\text{ V}$ OFF-HOOK	—	130	200		
	Pds48	$V_{BB} = -48\text{ V}$ ON-HOOK	—	100	150		
	Pd48	$V_{BB} = -48\text{ V}$ OFF-HOOK	—	280	420		
Loop Current	IL50	$R_L = 50\ \Omega$	26	30	34	mA	
	IL400	$R_L = 400\ \Omega$	26	30	34		
	IL1K	$R_L = 1\text{ k}\Omega$	—	—	—		
Relay Driver Output Voltage	$V_{RSI-RSO}$	$I_{RSI-RSO} = 30\text{ mA}$	-3	—	1.2	V	

AC Characteristics

($V_{BB} = -24/-48\text{ V}$, $V_{CC} = 5\text{ V}$, $V_{EE} = -5\text{ V}$, $T_a = 25^\circ\text{C}$)

Parameter		Symbol	Condition	Min.	Typ.	Max.	Unit
Transmit & Receive Gain	2W→4W	G_{24}	$V_i = 0\text{ dBm0}$ $f = 1\text{ kHz}$	—	4.0	—	dB
	4W→2W	G_{42}		—	-4.0	—	
Insertion Loss Variety	2W→4W	ΔL_{24}	$f = 0.3\text{ to }3.4\text{ kHz}$ $V_i = -55\text{ to }+3\text{ dBm0}$	-0.1	—	0.1	dB
	4W→2W	ΔL_{42}		-0.1	—	0.1	
Idel Channel Noise	2W	NI_2	Psohometric Filter	—	—	-81	dBm0P
	4W	NI_4		—	—	-81	
Signal to Distortion Ratio	2W→4W	SN_{24}	$f = 1\text{ kHz}$ $V_i = 0\text{ dBm0}$	53	—	—	dBp
	4W→2W	SN_{42}		53	—	—	
Longitudinal Balance	2W	LB_{2W}	$f = 0.3\text{ kHz to }3.4\text{ kHz}$	40	—	—	dB
	4W	LB_{4W}		40	—	—	
Return Loss		LM	$f = 0.3\text{ kHz to }3.4\text{ kHz}$	20	—	—	dB
Transhybrid Loss		LR	$f = 0.3\text{ kHz to }3.4\text{ kHz}$	23	—	—	dB
AC Induction Tolerance	2W→4W	I_{AC24}	$I_{AC} = 12.8\text{ mArms}$ $V_i = 0\text{ dBm0}$	53	—	—	dBp
	4W→2W	I_{AC42}		53	—	—	
Power Supply Rejection Ratio	$V_{BB} \rightarrow 2W$	LB_2	$f = 0.3\text{ kHz to }3.4\text{ kHz}$ $V_{in} = 24.5\text{ mVrms}$	20	—	—	dB
	$V_{CC} \rightarrow 2W$	LC_2		20	—	—	
	$V_{EE} \rightarrow 2W$	LE_2		20	—	—	
	$V_{BB} \rightarrow 4W$	LB_4	$f = 0.3\text{ kHz to }3.4\text{ kHz}$ $V_{in} = 24.5\text{ mVrms}$	20	—	—	dB
	$V_{CC} \rightarrow 4W$	LC_4		20	—	—	
	$V_{EE} \rightarrow 4W$	LE_4		20	—	—	

APPLICATION CIRCUIT

- V_{BB} : -48 V
- Loop Current I_L : 30 mA
- Equivalent Terminal Impedance : $600\Omega + 1\mu\text{F}$

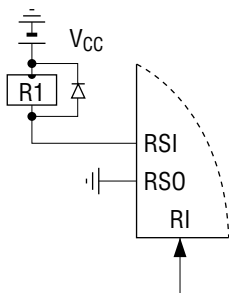
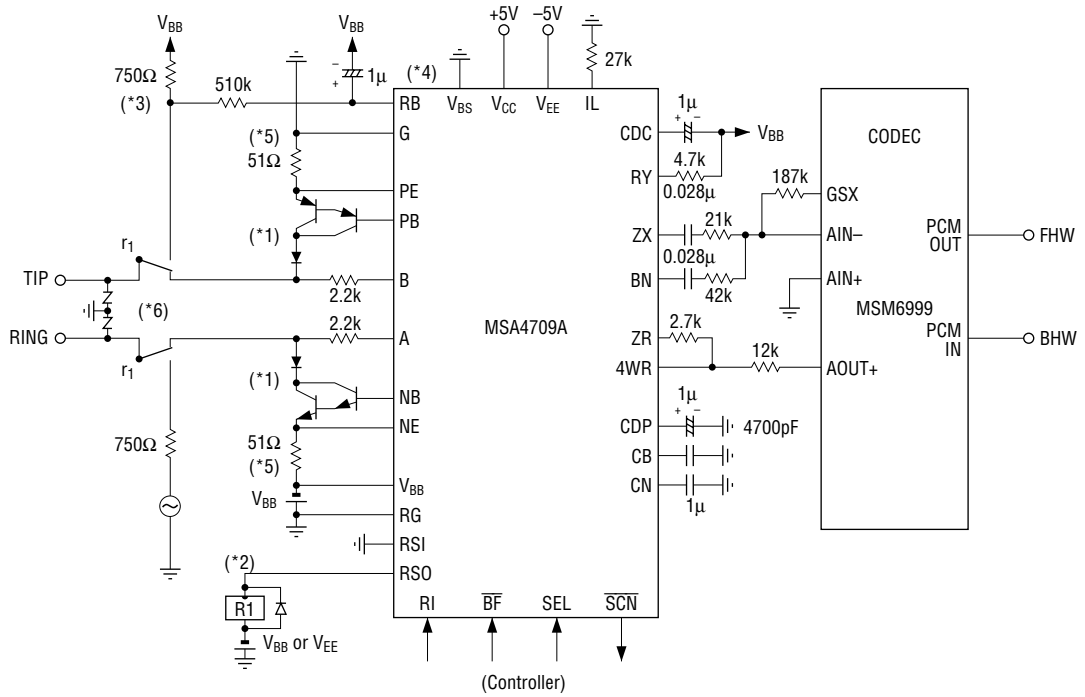

Fig. 1

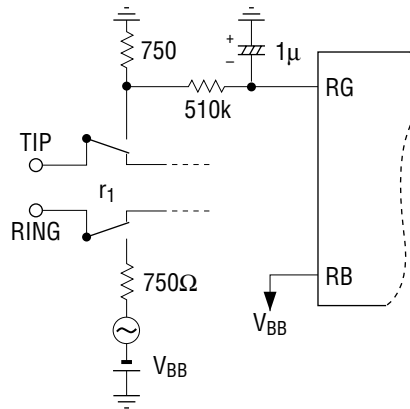
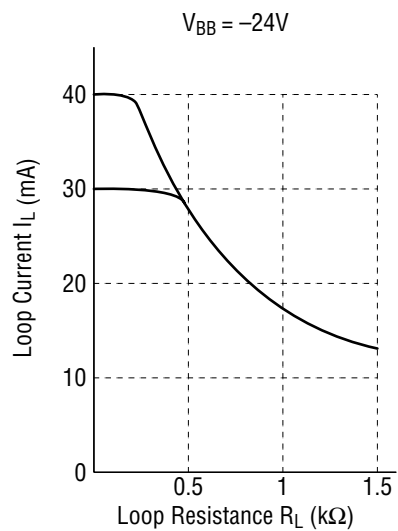
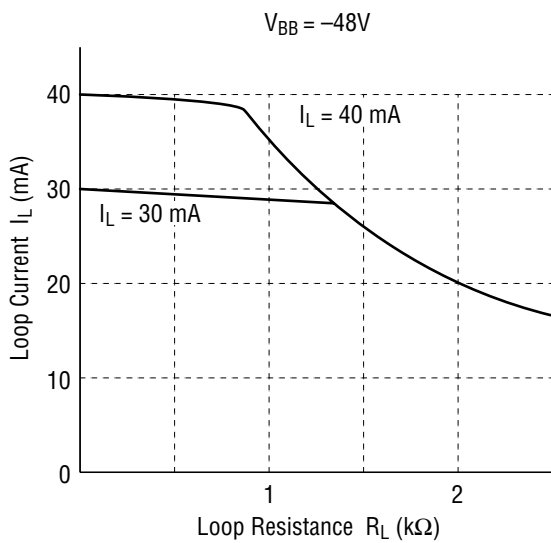

Fig. 2

- Notes:
- *1. Use heat sinks required for Darlington-connected power transistors.
 - *2. This diagram indicates that V_{BB} or V_{EE} (negative supply) is used for driving the relay, but a positive supply, such as V_{EE} indicated in Fig. 2, can also be used.
 - *3. This diagram indicates that the ring trip circuit consists of the RING line connected to ground through the ringing current source and the TIP line connected to the battery (V_{BB}), but the ring trip circuit can also be configured, using the RG pin indicated in Fig. 2, by the RING line connected to the battery through the ringing current source and the TIP line connected to ground.
 - *4. This diagram indicates $V_{BB} = -48V$. If $-24V$ is used for V_{BB} , connect the V_{BS} pin to V_{CC} and change the ring trip filtering constants from $510\text{ k}\Omega$ plus $1\text{ }\mu\text{F}$ to $150\text{ k}\Omega$ plus $33\text{ }\mu\text{F}$.
 - *5. Use a resistor with precision of 0.1% or better.
 - *6. Connect additional circuits for suppressing or absorbing surge and noise caused by relay contacts.

Battery Feed Characteristics



PACKAGE DIMENSIONS

(Unit : mm)

