

## MSC1157

### Speaker Drive Amplifier

#### GENERAL DESCRIPTION

The MSC1157, designed specifically to operate at a low voltage with low current consumption, is a power amplifier developed for driving a speaker for a voice IC.

The voltage gains can be adjusted over a range of up to ten. The differential output can directly drive a speaker without any output coupling capacitors. The MSC 1157, because of its ability to stand by, is ideally suitable for portable equipment applications powered by a battery.

#### FEATURES

- Low voltage operation : 2.0 to 6.0 V (Single power supply)
- Low current dissipation : 1.6mA without load (typ.)
- Standby function : Current dissipation less than 1  $\mu$ A in standby
- High output current : 350mA peak
- Differential outputs : A speaker can be directly connected between differential outputs.
- Adjustable gain : Gain can be adjusted by use of an external resistor.
- Package options:
  - 8-pin plastic DIP (DIP8-P-300-2.54) (Product name : MSC1157RS)
  - 8-pin plastic SOP (SOP8-P-250-1.27-K) (Product name : MSC1157MS-K)
  - Chip

#### BLOCK DIAGRAM

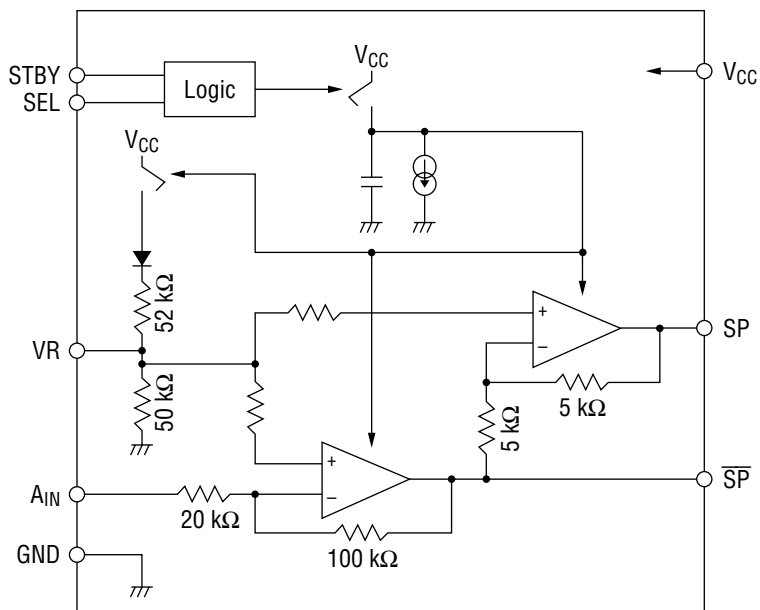

**PIN CONFIGURATION (TOP VIEW)**

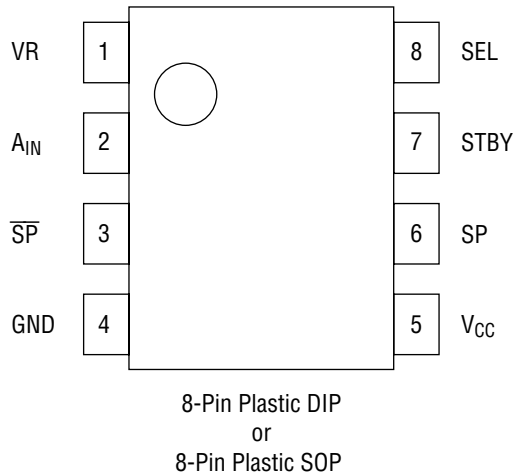

**PIN DESCRIPTIONS**

Pin	Symbol	Type	Description																								
5	V <sub>CC</sub>	—	Power supply pin.																								
4	GND	—	Ground pin.																								
2	A <sub>IN</sub>	I	Signal input pin for analog signal inputs, etc.																								
7, 8	STBY, SEL	I	<p>Digital input pins. Setting these pins configures the standby status. See the table below for how to set the pins.</p> <table border="1" style="margin-left: auto; margin-right: auto;"> <thead> <tr> <th>SEL</th> <th>STBY</th> <th>Status</th> </tr> </thead> <tbody> <tr> <td rowspan="3">0</td> <td>0</td> <td>Operation</td> </tr> <tr> <td>1</td> <td>Standby</td> </tr> <tr> <td>Clock</td> <td>Operation</td> </tr> <tr> <td rowspan="3">1</td> <td>0</td> <td>Standby</td> </tr> <tr> <td>1</td> <td>Operation</td> </tr> <tr> <td>Clock</td> <td>Operation</td> </tr> <tr> <td rowspan="3">Clock</td> <td>0</td> <td>Operation</td> </tr> <tr> <td>1</td> <td>Operation</td> </tr> <tr> <td>Clock</td> <td>Unstable Operation</td> </tr> </tbody> </table> <p>Applying a clock between 32kHz and 4MHz to either the STBY or the SEL pin leads the IC to operation status regardless of the status set at the other pin. Applying clocks to both of the pins at the same time may cause malfunction.</p> <p><u>Refer to the section, RECOMMENDED OPERATING CONDITIONS since clock frequencies are changed by setting the SEL pin.</u></p>	SEL	STBY	Status	0	0	Operation	1	Standby	Clock	Operation	1	0	Standby	1	Operation	Clock	Operation	Clock	0	Operation	1	Operation	Clock	Unstable Operation
SEL	STBY	Status																									
0	0	Operation																									
	1	Standby																									
	Clock	Operation																									
1	0	Standby																									
	1	Operation																									
	Clock	Operation																									
Clock	0	Operation																									
	1	Operation																									
	Clock	Unstable Operation																									
1	VR	0	<p>Bias output pin for internal circuits. This pin is at GND potential during standby. Connecting a capacitor between VR and the GND pin reduces the pop-up noise at power on and improves the ripple elimination ratio.</p>																								
3	SP-bar	0	Speaker output pin. This pin outputs a negative phase with respect to the input signal.																								
6	SP	0	Speaker output pin. This pin outputs a positive phase with respect to the input signal.																								

## ABSOLUTE MAXIMUM RATINGS

Parameter	Symbol	Condition	Rating	Unit	Remark
Power Supply Voltage	$V_{CC}$	$T_a=25^\circ\text{C}$	-0.3 to +6.5	V	$V_{CC}$
Input Voltage	$V_{IN}$	$T_a=25^\circ\text{C}$	-0.3 to $V_{CC}+0.3$	V	STBY $A_{IN}$ , SEL
Maximum Output Current	$I_{OMAX}$	$T_a=25^\circ\text{C}$	(*1) $\pm 400$	mA	SP, $\overline{SP}$
Power Dissipation	$P_D$	$T_a=25^\circ\text{C}$	470	mW	DIP type
			400	mW	SOP type
Junction Temperature	$T_{jMAX}$	—	125	$^\circ\text{C}$	Chip
Storage Temperature	$T_{STG}$	—	-55 to +150	$^\circ\text{C}$	

\*1 Avoid shorting the output pins (SP and  $\overline{SP}$ ) to  $V_{CC}$  or GND because the IC may be damaged.

## RECOMMENDED OPERATING CONDITIONS

Parameter	Symbol	Condition	Min.	Max.	Unit
Power Supply Voltage	$V_{CC}$	—	2.0	6.0	V
Load Impedance (*2)	$R_L$	—	8.0	—	$\Omega$
Peak Load Current	$I_{O-P}$	—	—	350	mA
"H" Input Voltage	$V_{IH}$	For STBY and SEL pins	0.7 $V_{CC}$	—	V
"L" Input Voltage	$V_{IL}$		—	0.3 $V_{CC}$	V
STBY Operating Frequency (*3)	$f_{STBY}$	SEL = "L" At clock input $V_{CC} \geq 2.4\text{ V}$	32 k	4.096 M	Hz
		SEL = "H" At clock input $V_{CC} \geq 2.4\text{ V}$	32 k	1 M	
Operating Temperature	$T_{op}$	—	-20	+70	$^\circ\text{C}$

\*2 A speaker of 8  $\Omega$  (standard) or more should be used.

\*3 The input of clocks may cause a little noise in output waveforms.

It is recommended to input the DC voltage to improve voice quality.

**ELECTRICAL CHARACTERISTICS**

Unless otherwise specified, Ta=25°C, VCC=2 to 6 V

Parameter	Symbol	Condition	Min.	Typ.	Max.	Unit	
A <sub>IN</sub> Input Resistance	R <sub>IN</sub>	—	14	20	26	kΩ	
Voltage Gain	A <sub>V1</sub>	A <sub>IN</sub> →SP	13.44	14	14.49	dB	
	A <sub>V2</sub>	SP→SP	-1.94	0	+1.58		
	A <sub>V3</sub>	A <sub>IN</sub> →(Between SP-SP)	19.46	20	20.51		
Output Power	P <sub>OUT1</sub>	V <sub>CC</sub> =3 V, f=1 kHz R <sub>L</sub> =8 Ω, THD≥10%	100	178	—	mW	
	P <sub>OUT2</sub>	V <sub>CC</sub> =6 V, f=1 kHz R <sub>L</sub> =32 Ω, THD≥10%	300	440	—	mW	
Total Harmonic Distortion	THD1	V <sub>CC</sub> =3 V, R <sub>L</sub> =8 Ω f=1 kHz, P <sub>OUT</sub> =45 mW	—	1.2	—	%	
	THD2	V <sub>CC</sub> =6 V, R <sub>L</sub> =32 Ω f=1 kHz, P <sub>OUT</sub> =125 mW	—	0.37	—	%	
Ripple Elimination Ratio	RR	f=1 kHz, C2=4.7 μF	30	43	—	dB	
Output DC Voltage (*4)	V <sub>O</sub>	In no signal state	V <sub>CC</sub> =2 V	0.53	0.65	0.77	V
		V <sub>CC</sub> =6 V	2.49	2.61	2.73		
Output Offset Voltage	ΔV <sub>O</sub>	Between SP-SP	—	—	±30	mV	
Output "H" Voltage	V <sub>OH</sub>	A <sub>IN</sub> =V <sub>CC</sub> or GND I <sub>OUT</sub> =-100 mA	V <sub>CC</sub> -1.15	V <sub>CC</sub> -1.04	—	V	
Output "L" Voltage	V <sub>OL</sub>	A <sub>IN</sub> =V <sub>CC</sub> or GND I <sub>OUT</sub> =100 mA	—	0.17	0.3	V	
STBY, SEL Input Current	I <sub>IH</sub>	V <sub>I</sub> =V <sub>CC</sub>	—	—	±0.1	μA	
	I <sub>IL</sub>	V <sub>I</sub> =GND	—	—	±0.1	μA	
VR Equivalent Resistance	R <sub>VR</sub>	—	18	25	32	kΩ	
Circuit Current During Operation	I <sub>CC</sub>	V <sub>CC</sub> =6 V, R <sub>L</sub> =∞	1.1	1.6	2.4	mA	
Circuit Current During Standby	I <sub>CCS</sub>	—	—	—	1.0	μA	

\*4 The typical value of the output voltage in no signal state is determined from the following equation.

$$V_O = (V_{CC} - 0.67) \frac{50 \text{ k}\Omega}{50 \text{ k}\Omega + 52 \text{ k}\Omega}$$

APPLICATION CIRCUIT

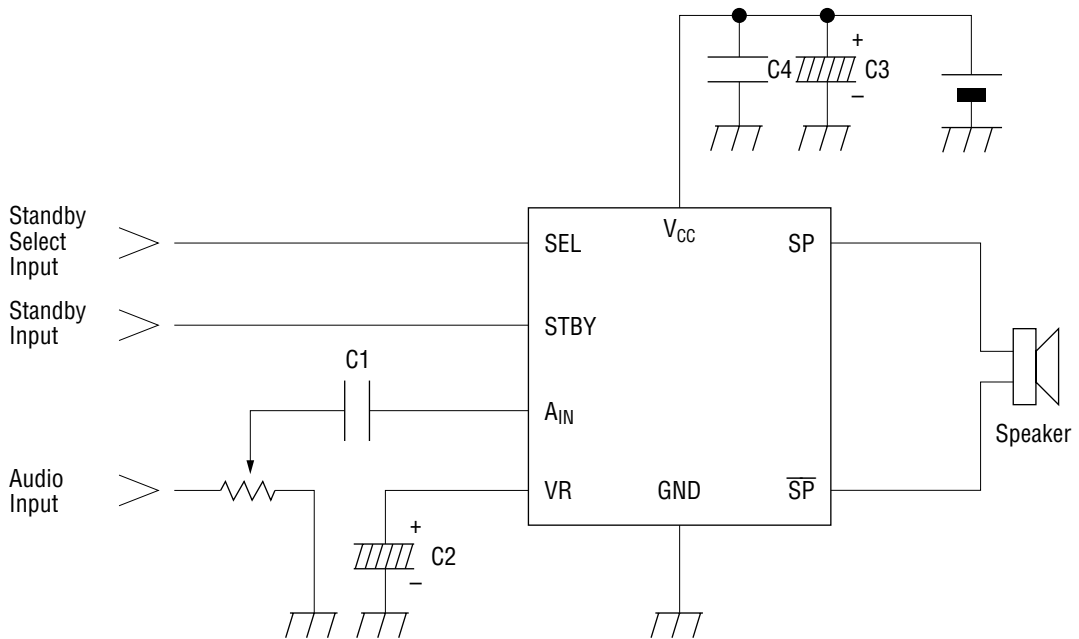

- If parasitic capacitance of 60pF or more exists between GND and the speaker output pin  $\overline{SP}$  or  $\overline{SP}$ , oscillation may occur. Implement the circuit mount design so as to be less than 60pF.
- C1 is the AC coupling capacitor. Cutoff frequency  $f_c$  on the low frequency side is determined by the following equation. Choose a value of C1 according to the bandwidth.

$$f_c = \frac{1}{2 \times \pi \times C1 \times 20k} \text{ (Hz)}$$

- Choose a value of C2 that is 80 to 100 times as large as that of C1.
- When the standby function is not used, connect the pins STBY and SEL to  $V_{CC}$  or GND.
- It is recommended that the capacitor C4 (approximately 0.1 $\mu$ F) having better high frequency characteristics and the capacitor C3 (approximately 10 $\mu$ F) be placed between the pins  $V_{CC}$  and GND.

## GAIN ADJUSTMENT

### 1. Gain Adjustment Using Input Resistance (This approach allows gain adjustment with fewer external components)

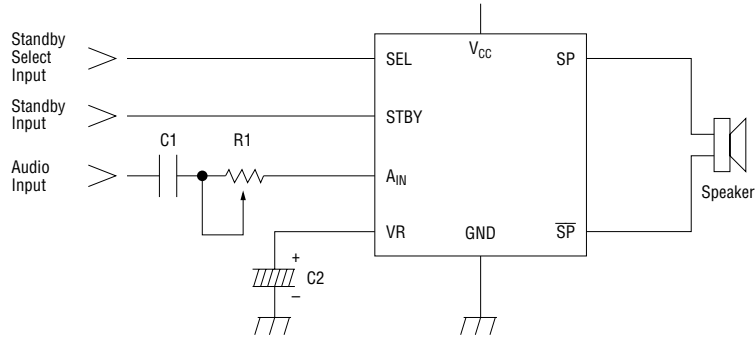

- Cutoff frequency  $f_c$  on the low frequency side is determined from the equation:

$$f_c \doteq \frac{1}{2 \times \pi \times C1 \times (R1 + 20k)} \text{ (Hz)}$$

- Voltage gain  $A_{V1}$  is determined from the equation:

$$A_{V1} \doteq \frac{100k}{R1 + 20k} \text{ (V/V)}$$

### 2. Gain Adjustment Using Feedback Resistance (This approach has the advantage over the above approach (less noise approach), but the number of components is increased)

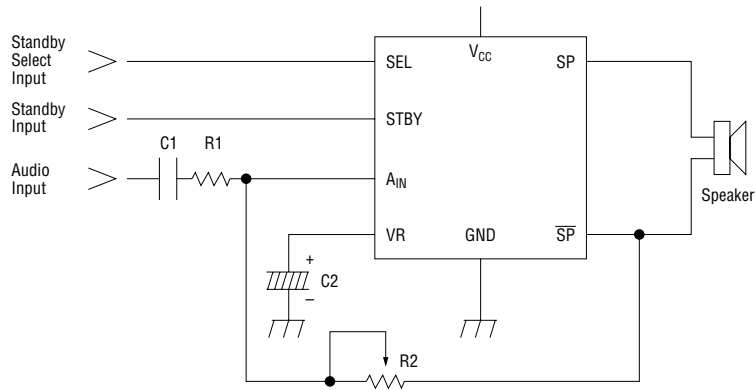

- Cutoff frequency  $f_c$  on the low frequency side is determined from the equation:

$$f_c \doteq \frac{1}{2 \times \pi \times C1 \times Z_{in}} \text{ (Hz)} \quad Z_{in} \doteq R1 + \frac{R2 \times 20k}{R2 + 120k} \text{ (\Omega)}$$

- Voltage gain  $A_{V1}$  is determined from the equation:

$$A_{V1} \doteq \frac{5}{1 + \frac{R1}{20k} + \frac{6 \times R1}{R2}} \text{ (V/V)}$$

### OPERATING CHARACTERISTICS

Power Dissipation vs. Ambient Temperature

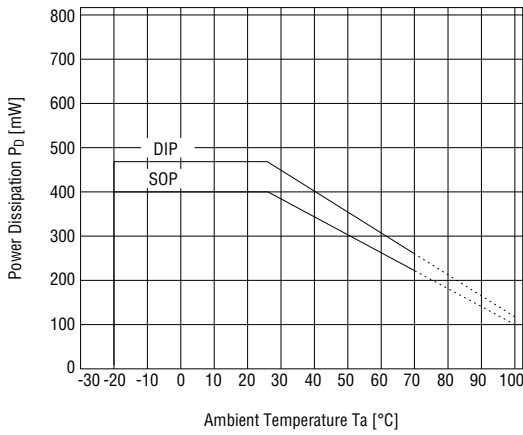

Maximum Output Amplitude vs. Voltage Supply

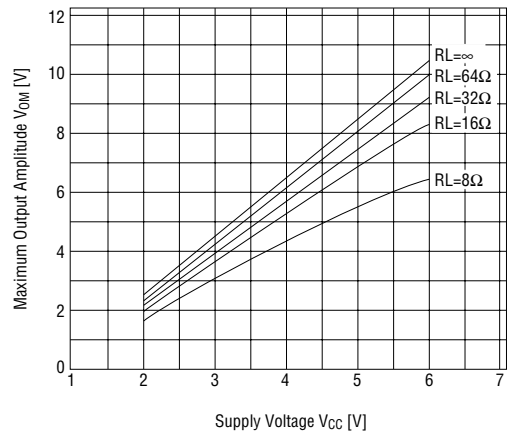

Power Dissipation vs. Output Power

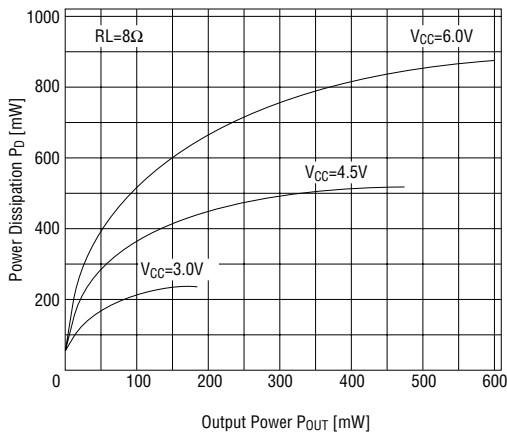

Power Dissipation vs. Output Power

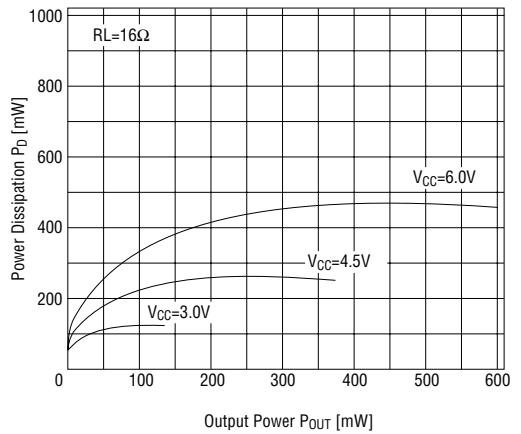

Power Dissipation vs. Output Power

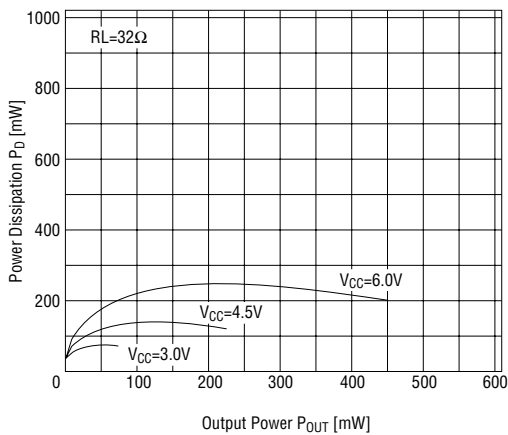

Power Dissipation vs. Output Power

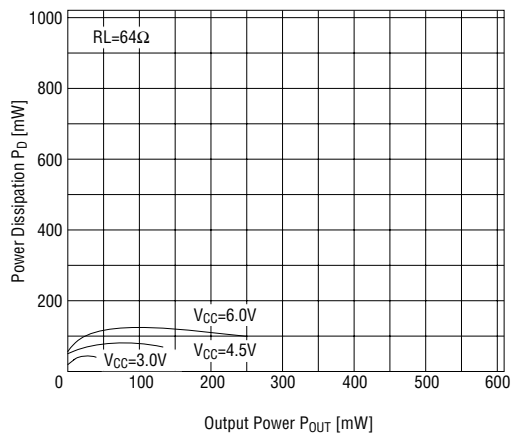

Circuit Current vs. Voltage Supply

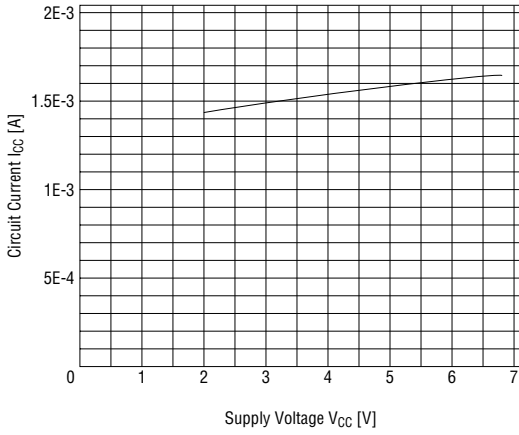

VR Rise Time vs. Capacitor Value (C2)

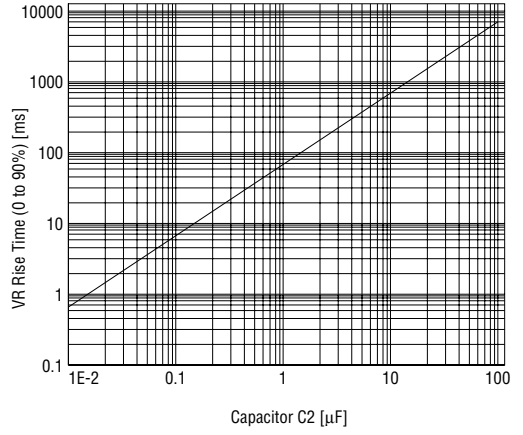

Output Voltage vs. Load Current

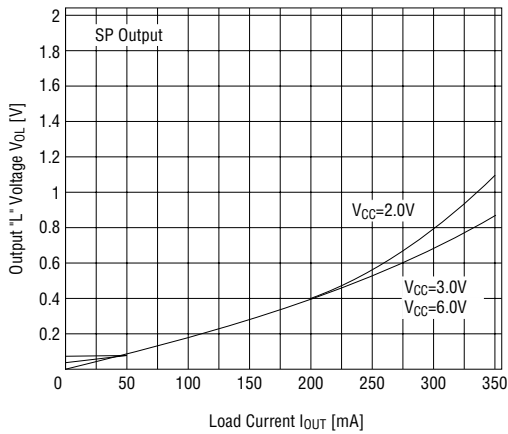

Output Voltage vs. Load Current

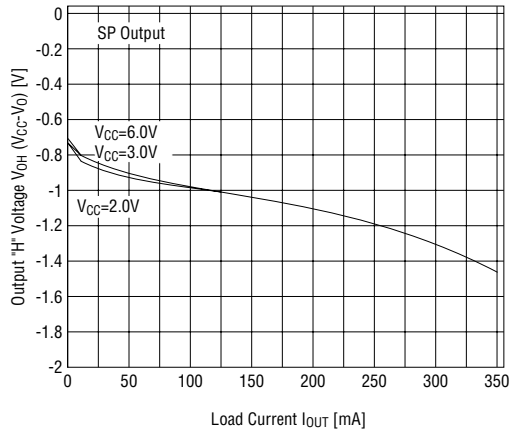

Output Voltage vs. Load Current

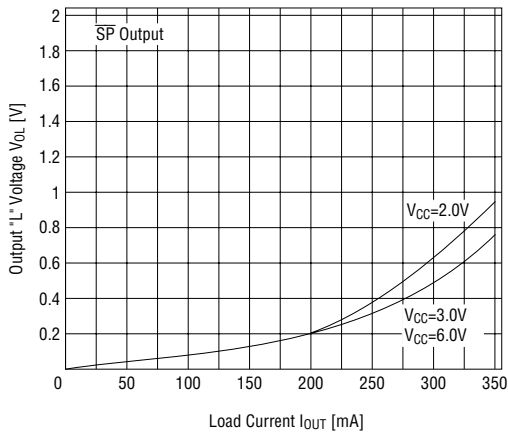

Output Voltage vs. Load Current

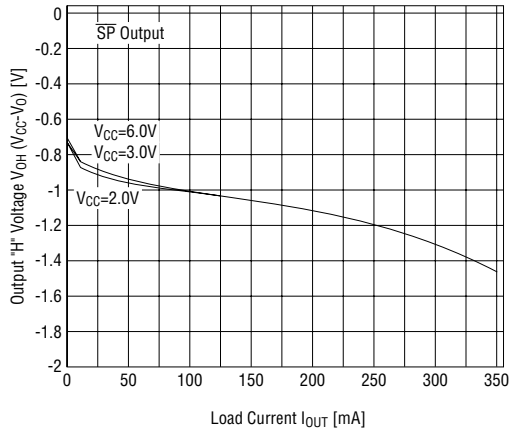



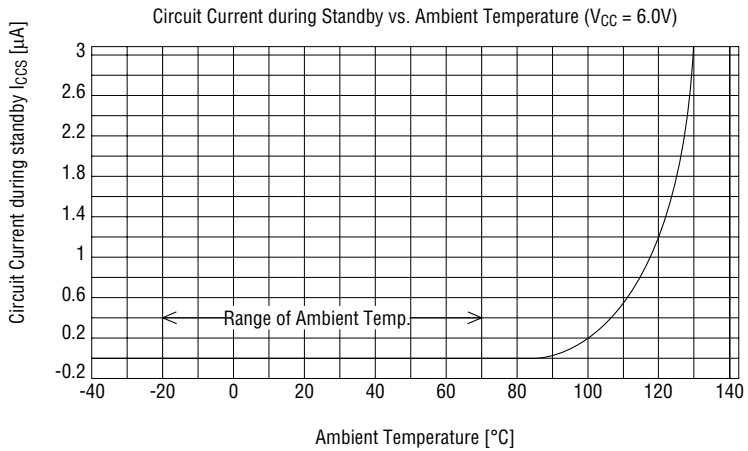
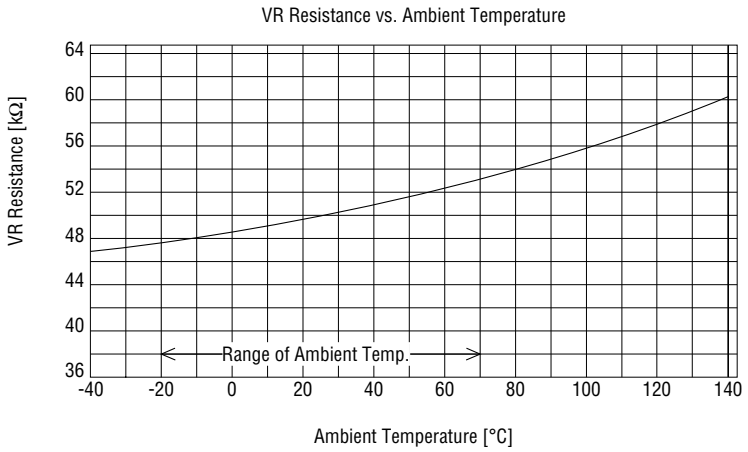
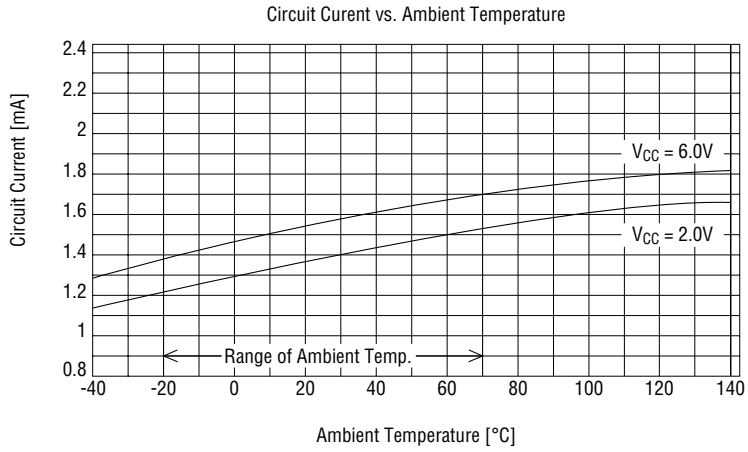

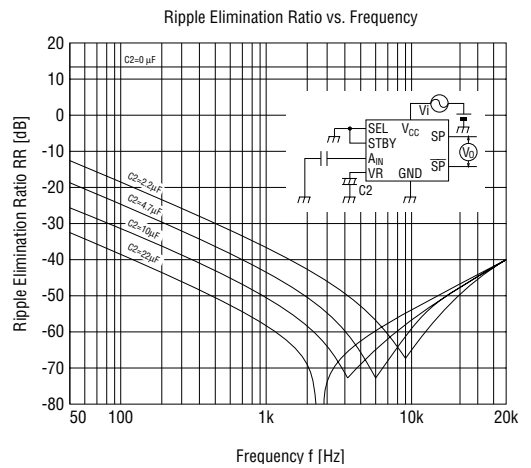
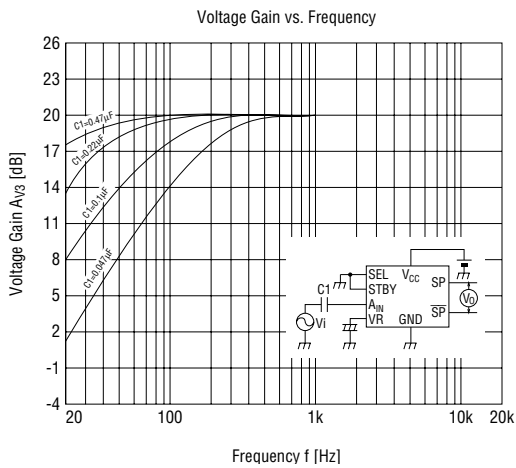
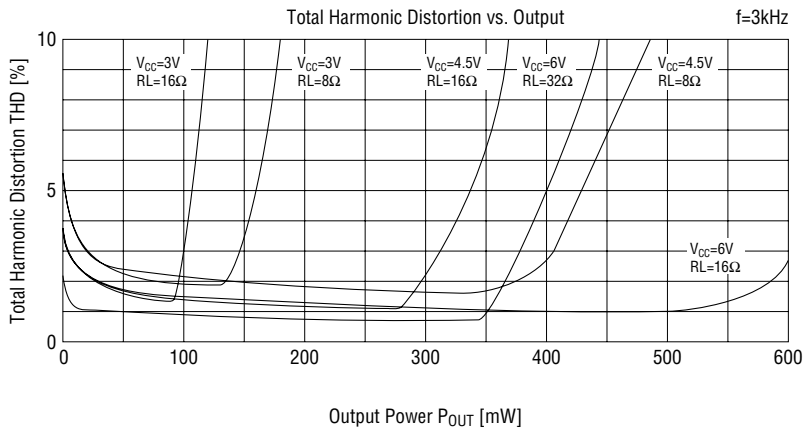
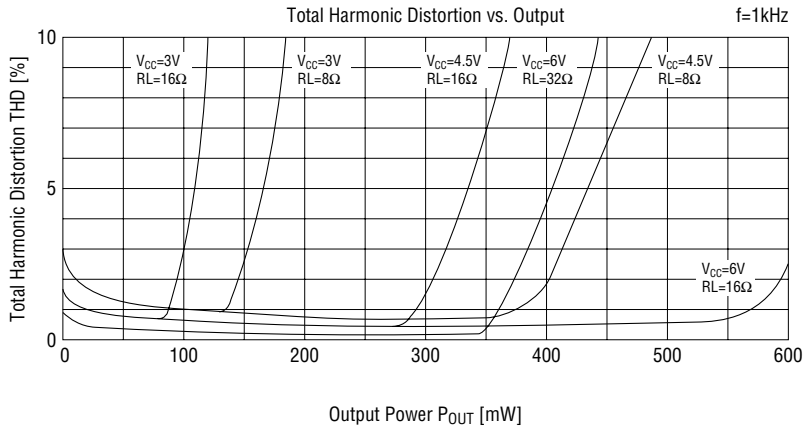

**PAD CONFIGURATION**

**Pad Layout**

Chip size : X=2.3mm, Y=2.4mm  
 Chip thickness : 350±30µm  
 Pad size (PV aperture) : 110×110µm  
 Substrate potential : GND  
 Pad location diagram

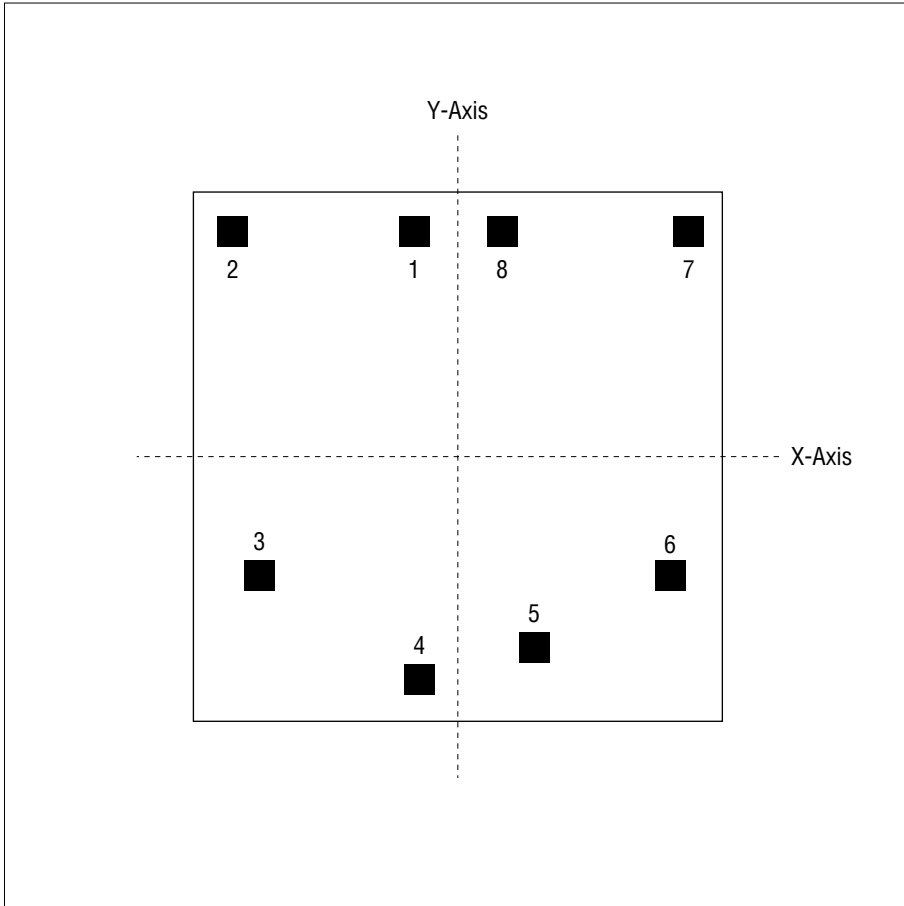

**Pad Coordinates**

(Chip center is located at X=0 and Y=0.)

(Unit: µm)

Pad No.	Pad Name	X-AXIS	Y-AXIS
1	VR	-133	1035
2	A <sub>IN</sub>	-985	1035
3	SP	-950	-263
4	GND	-180	-1027
5	V <sub>CC</sub>	240	-914
6	SP	950	-263
7	STBY	985	1035
8	SEL	159	1035

PACKAGE DIMENSIONS

(Unit : mm)

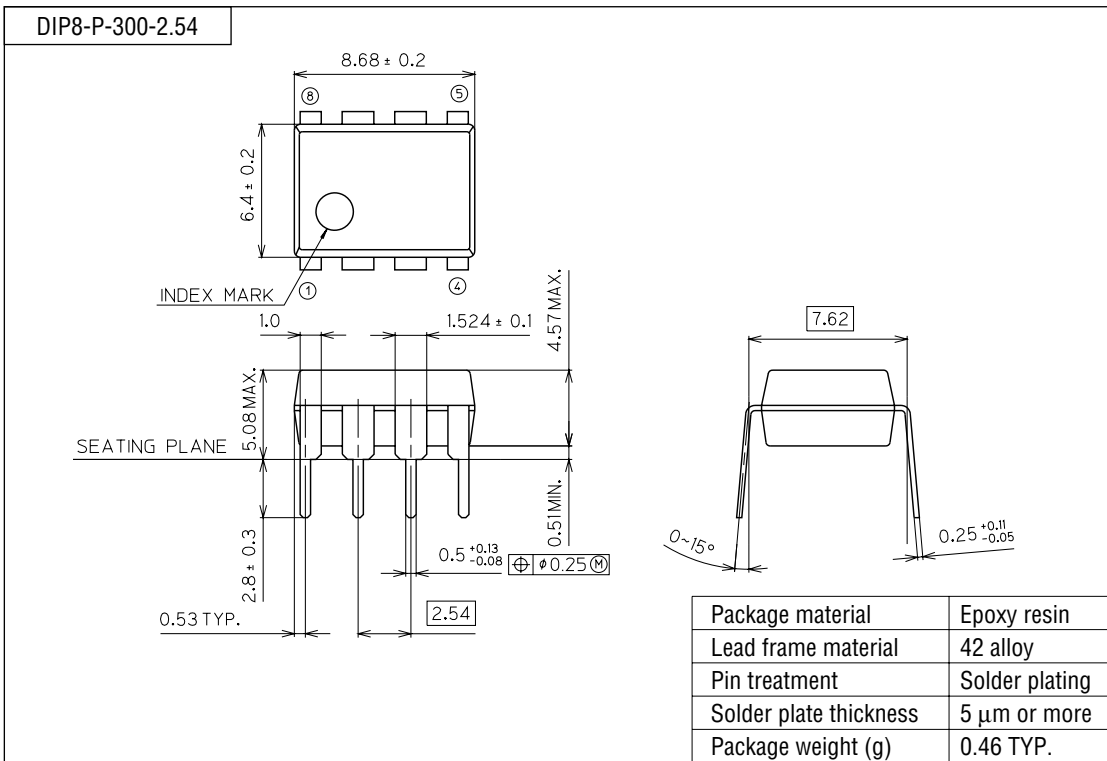



NOTICE

1. The information contained herein can change without notice owing to product and/or technical improvements. Before using the product, please make sure that the information being referred to is up-to-date.
2. The outline of action and examples for application circuits described herein have been chosen as an explanation for the standard action and performance of the product. When planning to use the product, please ensure that the external conditions are reflected in the actual circuit, assembly, and program designs.
3. When designing your product, please use our product below the specified maximum ratings and within the specified operating ranges including, but not limited to, operating voltage, power dissipation, and operating temperature.
4. Oki assumes no responsibility or liability whatsoever for any failure or unusual or unexpected operation resulting from misuse, neglect, improper installation, repair, alteration or accident, improper handling, or unusual physical or electrical stress including, but not limited to, exposure to parameters beyond the specified maximum ratings or operation outside the specified operating range.
5. Neither indemnity against nor license of a third party's industrial and intellectual property right, etc. is granted by us in connection with the use of the product and/or the information and drawings contained herein. No responsibility is assumed by us for any infringement of a third party's right which may result from the use thereof.
6. The products listed in this document are intended for use in general electronics equipment for commercial applications (e.g., office automation, communication equipment, measurement equipment, consumer electronics, etc.). These products are not authorized for use in any system or application that requires special or enhanced quality and reliability characteristics nor in any system or application where the failure of such system or application may result in the loss or damage of property, or death or injury to humans. Such applications include, but are not limited to, traffic and automotive equipment, safety devices, aerospace equipment, nuclear power control, medical equipment, and life-support systems.
7. Certain products in this document may need government approval before they can be exported to particular countries. The purchaser assumes the responsibility of determining the legality of export of these products and will take appropriate and necessary steps at their own expense for these.
8. No part of the contents contained herein may be reprinted or reproduced without our prior permission.
9. MS-DOS is a registered trademark of Microsoft Corporation.

Copyright 1999 Oki Electric Industry Co., Ltd.