

RF & MICROWAVE TRANSISTORS AVIONICS APPLICATIONS

- REFRACTORY/GOLD METALLIZATION
- EMITTER SITE BALLASTED
- ∞:1 VSWR CAPABILITY
- LOW THERMAL RESISTANCE
- INPUT MATCHING
- OVERLAY GEOMETRY
- METAL/CERAMIC HERMETIC PACKAGE
- P_{OUT} = 35 W MIN. WITH 10.7 dB GAIN

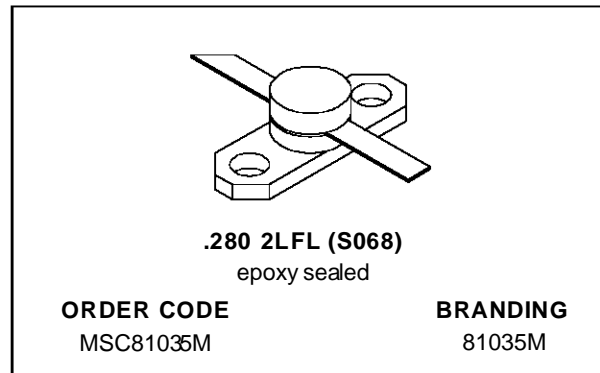

DESCRIPTION

The MSC81035M is a medium power Class C transistor designed specifically for pulsed L-Band avionics applications. This device is a direct replacement for the MSC1035M. MSC81035M offers improved saturated output power and collector efficiency based on the test circuit described herein.

Low RF thermal resistance and computerized automatic wire bonding techniques ensure high reliability and product consistency.

The MSC81035M is housed in the IMPAC™ package with internal input matching.

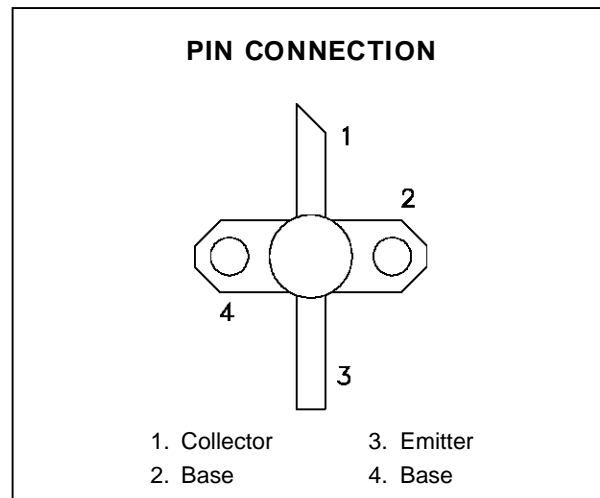

ABSOLUTE MAXIMUM RATINGS (T_{case} = 25°C)

Symbol	Parameter	Value	Unit
P _{DISS}	Power Dissipation* (T _c ≤ 100°C)	150	W
I _c	Device Current*	3.0	A
V _{CC}	Collector-Supply Voltage*	55	V
T _J	Junction Temperature (Pulsed RF Operation)	250	°C
T _{STG}	Storage Temperature	- 65 to +200	°C

THERMAL DATA

R _{TH(j-c)}	Junction-Case Thermal Resistance*	1.0	°C/W
----------------------	-----------------------------------	-----	------

*Applies only to rated RF amplifier operation

Note: Thermal Resistance determined by Infra-Red Scanning of Hot-Spot Junction Temperature at rated RF operating conditions.

MSC81035M

ELECTRICAL SPECIFICATIONS (T_{case} = 25°C)

STATIC

Symbol	Test Conditions		Value			Unit
			Min.	Typ.	Max.	
BV _{CBO}	I _C = 10 mA	I _E = 0 mA	65	—	—	V
BV _{EBO}	I _E = 1 mA	I _C = 0 mA	3.5	—	—	V
BV _{CER}	I _C = 10 mA	R _{BE} = 10 Ω	65	—	—	V
I _{CES}	V _{BE} = 0 V	V _{CE} = 50 V	—	—	5	mA
h _{FE}	V _{CE} = 5 V	I _C = 500 mA	15	—	120	—

DYNAMIC

Symbol	Test Conditions			Value			Unit
				Min.	Typ.	Max.	
P _{OUT}	f = 1025 – 1150 MHz	P _{IN} = 3.0 W	V _{CC} = 50 V	35	40	—	W
η _C	f = 1025 – 1150 MHz	P _{IN} = 3.0 W	V _{CC} = 50 V	40	—	—	%
P _G	f = 1025 – 1150 MHz	P _{IN} = 3.0 W	V _{CC} = 50 V	10.7	11.2	—	dB

Note: Pulse Width = 10μSec
Duty Cycle = 1%

TYPICAL PERFORMANCE

TYPICAL BROADBAND POWER AMPLIFIER

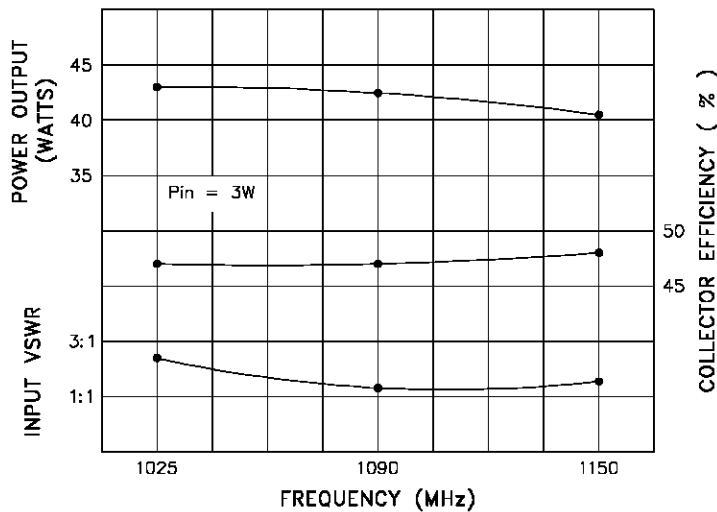

IMPEDANCE DATA

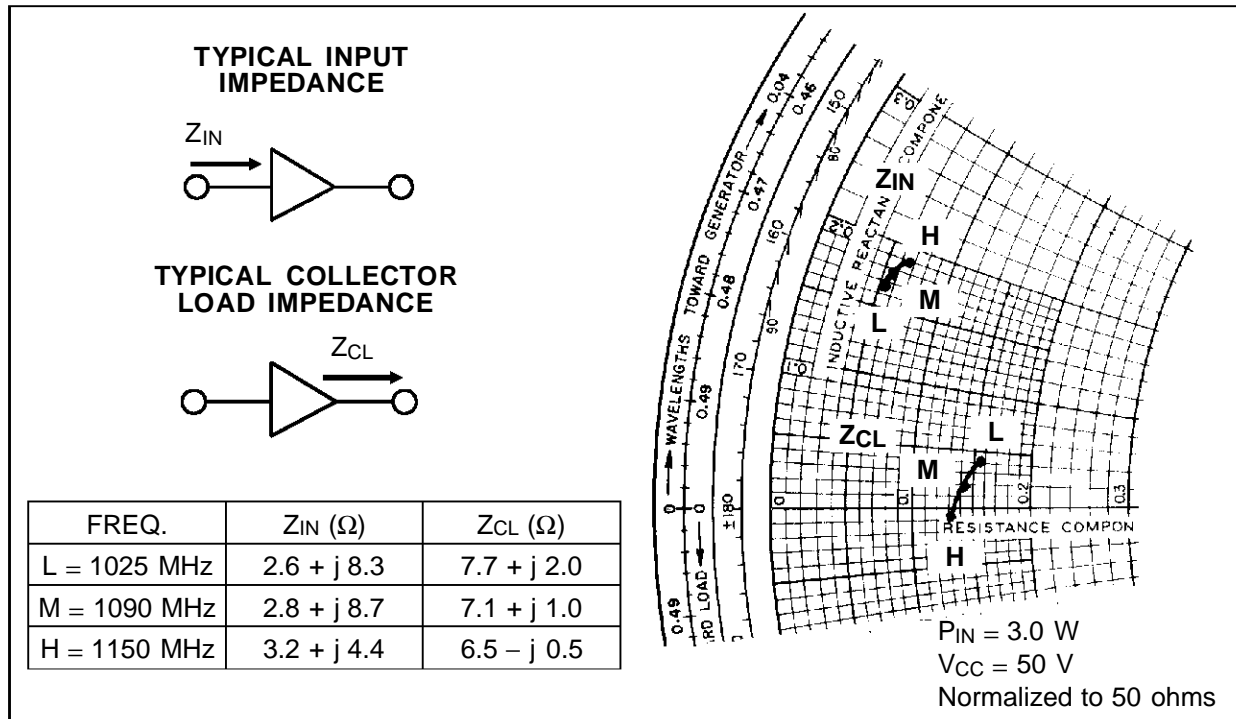

TEST CIRCUIT

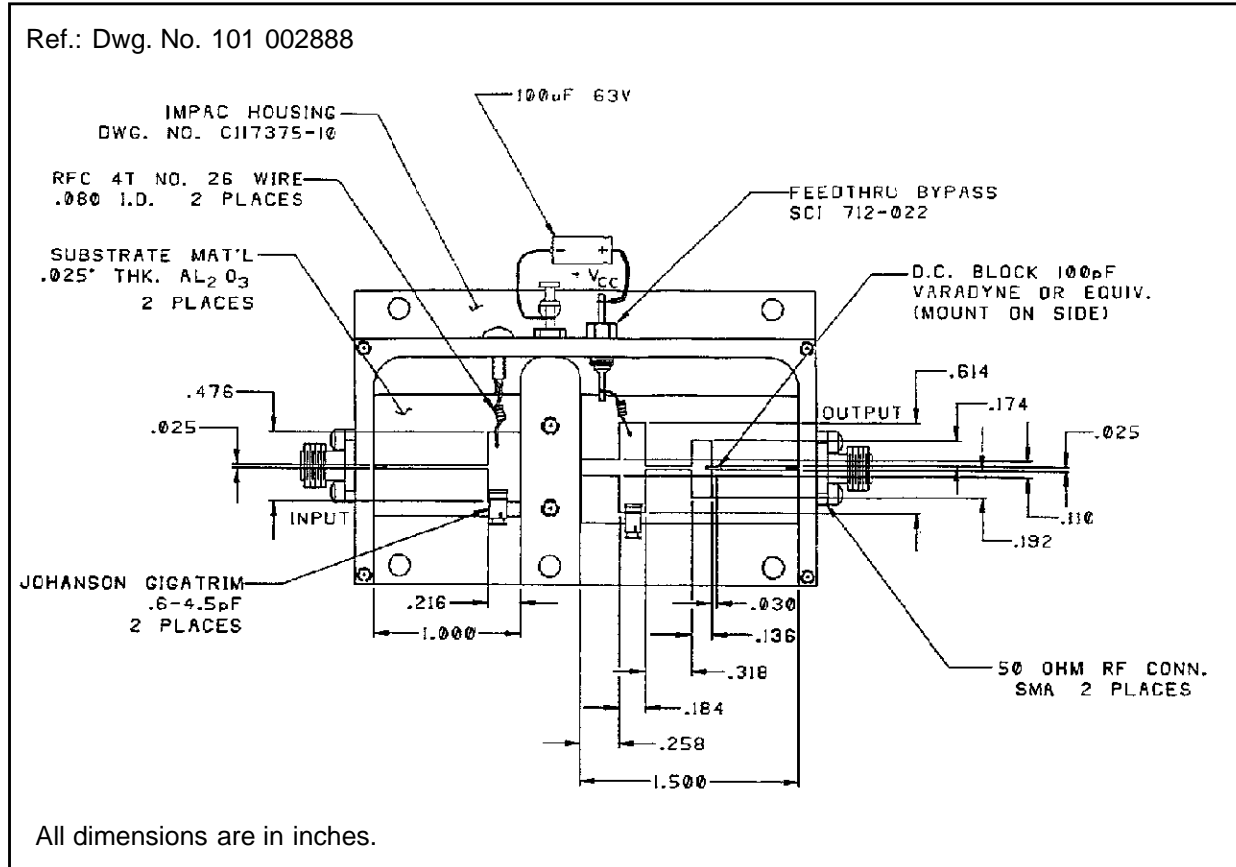

PACKAGE MECHANICAL DATA

Ref.: Dwg. No. 12-0218 rev. A

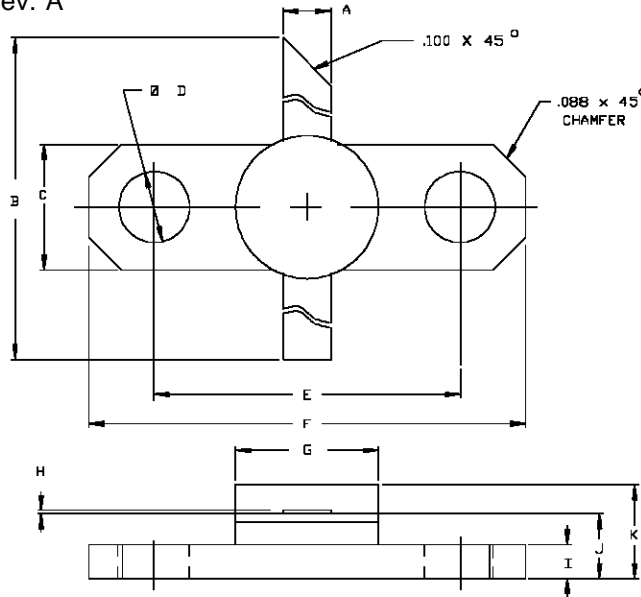

SGS-THOMSON MICROELECTRONICS		CONT'D			
	MINIMUM Inches/mm	MAXIMUM Inches/mm		MINIMUM Inches/mm	MAXIMUM Inches/mm
A	.095/2,41	.105/2,67	I	.052/1,32	.072/1,83
B	1.050/26,67		J	.120/3,05	.130/3,30
C	.245/6,22	.255/6,48	K		.210/5,33
D	.120/3,05	.140/3,56			
E	.552/14,02	.572/14,53			
F	.790/20,07	.810/20,57			
G		.285/7,24			
H	.003/0,08	.007/0,18			

Information furnished is believed to be accurate and reliable. However, SGS-THOMSON Microelectronics assumes no responsibility for the consequences of use of such information nor for any infringement of patents or other rights of third parties which may result from its use. No license is granted by implication or otherwise under any patent or patent rights of SGS-THOMSON Microelectronics. Specifications mentioned in this publication are subject to change without notice. This publication supersedes and replaces all information previously supplied. SGS-THOMSON Microelectronics products are not authorized for use as critical components in life support devices or systems without express written approval of SGS-THOMSON Microelectronics.

©1994 SGS-THOMSON Microelectronics - All Rights Reserved

SGS-THOMSON Microelectronics GROUP OF COMPANIES

Australia - Brazil - France - Germany - Hong Kong - Italy - Japan - Korea - Malaysia - Malta - Morocco - The Netherlands - Singapore - Spain - Sweden - Switzerland - Taiwan - Thailand - United Kingdom - U.S.A.