

MSF1425A

X-Band Magnetron

MSF1425A is designed for the magnetron of X-band radar system.

The frequency range is fixed between 9.345GHz and 9.405GHz. The peak output power is 12.5kW.

----- MAXIMUM RATINGS -----

	Min	Max	Unit
Peak anode current	3.0	7.0	A
Peak anode power input	-	50	kW
Duty cycle	-	0.001	-
Pulse duration	0.05	1.0	us
Rate of rise of voltage pulse	-	90	kV/us
Anode temperature	-	100	°C
V.S.W.R. at the output coupler	-	1.5:1	-

----- ELECTRICAL -----

	Min	Typical	Max	Unit
Heater voltage(Note 1)	5.7	6.3	6.9	V
Preheat time	60	-	-	S
Peak anode voltage (Note 2)	5.4	5.6	6.0	KV
Peak output power (Note 2)	10	10.5	-	KW
Frequency (Note2)	9.345	9.375	9.405	GHz

Note:

1. Measured with heater voltage of 6.3V and no anode input power, the heater current limits are 0.5A minimum, 0.6A maximum. No reduction of heater voltage is required.
2. Measured at peak anode current 5.0A.

For further information on the use of the magnetron, Please contact New JRC. New JRC reserves the right to change the specification of goods without notice.

Rev.1

OUTLINE

MSF 1425A

Note: Dimensions are in mm

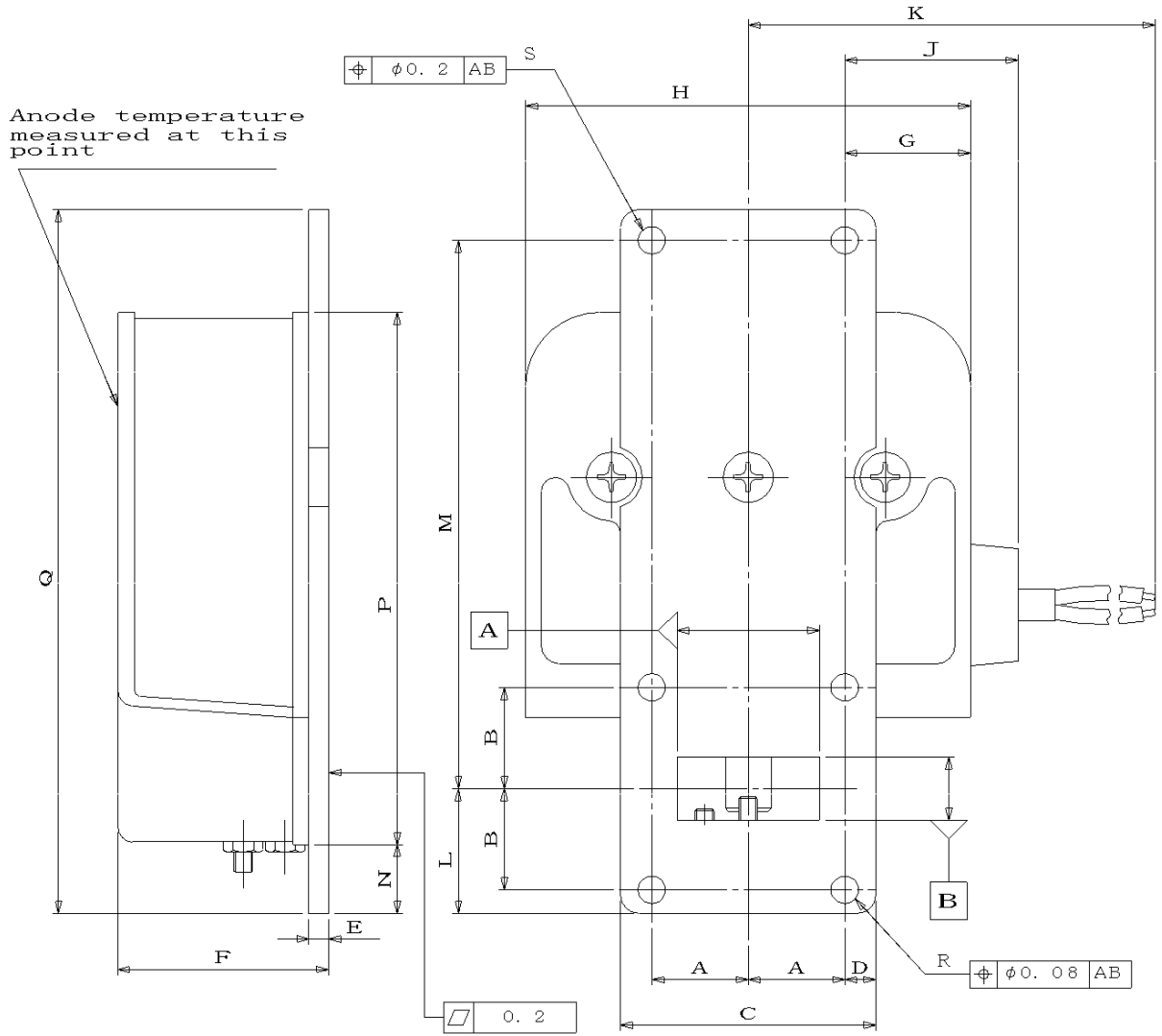

	MIN	MAX
A	15.5	
B	16.25	
C	40.8	41.2
D	4.8	5.2
E	2.7	3.7
F	-	36.0
G	-	21.5
H	-	74.0

	MIN	MAX
J	-	30.0
K	240	-
L	19.6	20.2
M	88	
N	10.0	-
P	-	86.0
Q	112.6	113.2
R	φ4.3	φ4.375
S	φ4.4	φ4.5

Lead Connections

Colour	Element
Green	Heater
Yellow	Heater, Cathode