

MSK

M.S.KENNEDY CORP.

**HIGH VOLTAGE
OPERATIONAL AMPLIFIER****0004**

4707 Dey Road Liverpool, N.Y. 13088

(315) 701-6751

MIL-PRF-38534 QUALIFIED**FEATURES:**

- Pin Similar Replacement for the LH0004
- Wide Supply Voltage Range: $\pm 10V$ to $\pm 50V$
- Low Offset Current: 15nA
- High Voltage Gain: 200KV/V
- Internal Compensation
- Output Overload Protection
- Thermal Overload Protection

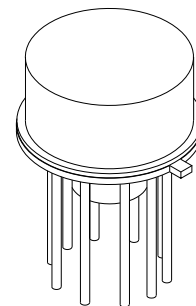
**DESCRIPTION:**

The MSK 0004 is a high voltage operational amplifier for use in high performance signal conditioning applications, as well as resolver excitation designs. These devices offer maximum reliability by providing internal output overload protection and thermal overload protection. Monolithic design and internal compensation make the MSK 0004 an excellent replacement for many general purpose operational amplifiers and specifically the LH0004. The MSK 0004 is internally compensated and can replace the LH0004 in most applications without any changes to existing circuitry. The device is packaged in an hermetically sealed 10 pin metal can.

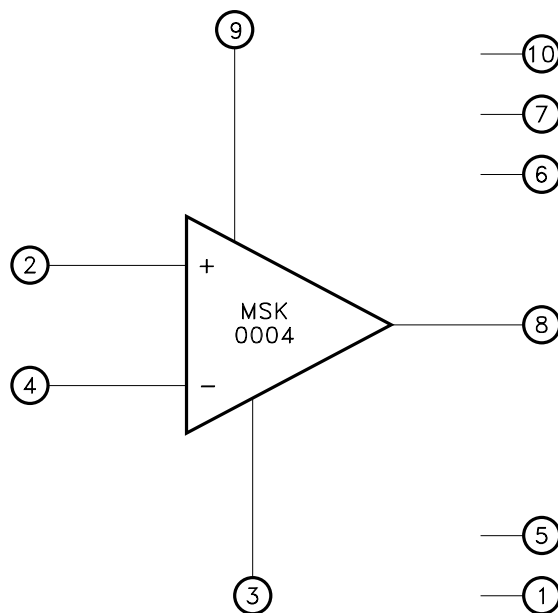
EQUIVALENT SCHEMATIC**TYPICAL APPLICATIONS**

- Precision High Voltage Power Supply
- High Voltage Regulators
- Signal Conditioning
- Resolver Excitation
- Transducer Power Supply

PIN-OUT INFORMATION

1 NC	10 NC
2 + Input	9 + Vcc
3 -Vcc	8 Output
4 -Input	7 NC
5 NC	6 NC

ABSOLUTE MAXIMUM RATINGS

V _{CC}	Supply Voltage	± 50V	T _{ST}	Storage Temperature Range	-65°C to + 150°C
V _{IN}	Differential Input Voltage	± 40V	T _{LD}	Lead Temperature Range	300°C
T _C	Case Operating Temperature Range			(10 Seconds)	
	MSK0004H/E	-55°C to + 125°C	T _C	Junction Temperature	175°C
	MSK0004	-40°C to + 85°C			

ELECTRICAL SPECIFICATIONS

Parameter	Test Conditions ①	Group A Subgroup	MSK0004H/E			MSK0004			Units
			Min.	Typ.	Max.	Min.	Typ.	Max.	
STATIC									
Supply Voltage Range ②		-	± 10	± 40	± 50	± 10	± 40	± 45	V
Quiescent Current		1	-	± 3.0	± 4.5	-	± 3.0	± 5.0	mA
		2,3	-	-	± 4.5	-	-	-	mA
INPUT									
Input Offset Voltage	AV = 10	1	-	± 1.0	± 6.0	-	± 1.0	± 7.5	mV
		2,3	-	-	± 7.0	-	-	-	mV
Input Offset Voltage Drift ②		-	-	± 15	-	-	± 15	-	μV/°C
Input Bias Current ②	V _{CM} = 0V	1	-	± 12	± 30	-	± 12	± 50	nA
		2,3	-	-	± 50	-	-	-	nA
Input Offset Current ②	V _{CM} = 0V	1	-	± 15	± 30	-	± 15	± 40	nA
Common Mode Rejection Ratio ②	V _{CM} = ± 20V _{DC}	-	74	100	-	74	100	-	dB
Input Impedance ②	DC	-	40	250	-	40	250	-	MΩ
OUTPUT									
Output Voltage Swing	f = 1KHz	4	± 35	± 37	-	± 35	± 37	-	V
Power Bandwidth ②	V _{OUT} = ± 35V _{PK}	-	-	23	-	-	23	-	KHz
Output Resistance ②	No Load	-	-	500	-	-	500	-	Ω
Capacitive Load ②	R _L = 1KΩ	-	-	50	-	-	50	-	pF
TRANSFER CHARACTERISTICS									
Slew Rate	V _{OUT} = ± 30V _{PK}	4	2.5	5.0	-	2.5	5.0	-	V/μS
Open Loop Voltage Gain ②	V _{OUT} = ± 30V _{PK} f = 10KHz	4	100K	200K	-	100K	200K	-	V/V
Thermal Resistance	Junction to Case @ 125°C	-	-	16	19	-	16	22	°C/W

NOTES:

- ① Unless otherwise specified, V_{CC} = ± 40V_{DC} and V_{IN} = 0V.
- ② Guaranteed by design but not tested. Typical parameters are representative of actual device performance but are for reference only.
- ③ Industrial grade and "E" suffix devices shall be tested to subgroups 1 and 4 unless otherwise requested.
- ④ Military grade devices ("H" suffix) shall be 100% tested to subgroups 1,2,3 and 4.
- ⑤ Subgroup 5 and 6 testing available upon request.
- ⑥ Subgroup 1,4 T_C = +25°C
Subgroup 2,5 T_C = +125°C
Subgroup 3,6 T_A = -55°C

APPLICATION NOTES

POWER SUPPLY BYPASSING

Both the negative and positive power supplies must be effectively decoupled with a high and low frequency bypass circuit to avoid power supply induced oscillation. An effective decoupling scheme consists of a 0.1 microfarad ceramic capacitor in parallel with a 4.7 microfarad tantalum capacitor from each power supply pin to ground.

HEAT SINKING

To determine if a heat sink is necessary for your application and if so, what type, refer to the thermal model and governing equation below.

Thermal Model:

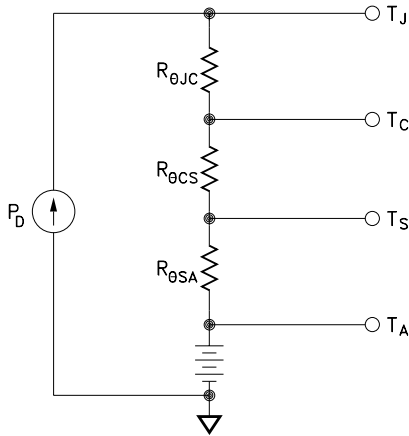

Governing Equation:

$$T_J = P_D \times (R_{\theta JC} + R_{\theta CS} + R_{\theta SA}) + T_A$$

Where

T_J	=	Junction Temperature
P_D	=	Total Power Dissipation
$R_{\theta JC}$	=	Junction to Case Thermal Resistance
$R_{\theta CS}$	=	Case to Heat Sink Thermal Resistance
$R_{\theta SA}$	=	Heat Sink to Ambient Thermal Resistance
T_C	=	Case Temperature
T_A	=	Ambient Temperature
T_S	=	Sink Temperature

Example:

The example demonstrates a worst case analysis for the op-amp output stage. This occurs when the output voltage is 1/2 the power supply voltage. Under this condition, maximum power transfer occurs and the output is under maximum stress.

Conditions:

$$V_{CC} = \pm 40\text{VDC}$$

$$V_O = \pm 20\text{Vp Sine Wave, Freq.} = 1\text{KHz}$$

$$R_L = 1\text{K}\Omega$$

For a worst case analysis we treat the $\pm 20\text{Vp}$ sine wave as an 8 VDC output voltage.

1.) Find driver power dissipation

$$\begin{aligned} P_D &= (V_{CC} - V_O) (V_O / R_L) \\ &= (40\text{V} - 20\text{V}) (20\text{V} / 1\text{K}\Omega) \\ &= 400\text{mW} \end{aligned}$$

2.) For conservative design, set $T_J = +125^\circ\text{C}$.

3.) For this example, worst case $T_A = +100^\circ\text{C}$.

4.) $R_{\theta JC} = 16^\circ\text{C/W}$.

5.) $R_{\theta CS} = 0.15^\circ\text{C/W}$ for most thermal greases.

6.) Rearrange governing equation to solve for $R_{\theta SA}$:

$$\begin{aligned} R_{\theta SA} &= ((T_J - T_A) / P_D) - (R_{\theta JC}) - (R_{\theta CS}) \\ &= (125^\circ\text{C} - 100^\circ\text{C}) / 0.4\text{W} - 16^\circ\text{C/W} - 0.15^\circ\text{C/W} \\ &= 62.5 - 16.15 \\ &= 46.4^\circ\text{C/W} \end{aligned}$$

The heat sink in this example must have a thermal resistance of no more than 46.4°C/W to maintain a junction temperature of less than $+125^\circ\text{C}$.

TYPICAL APPLICATION CIRCUIT

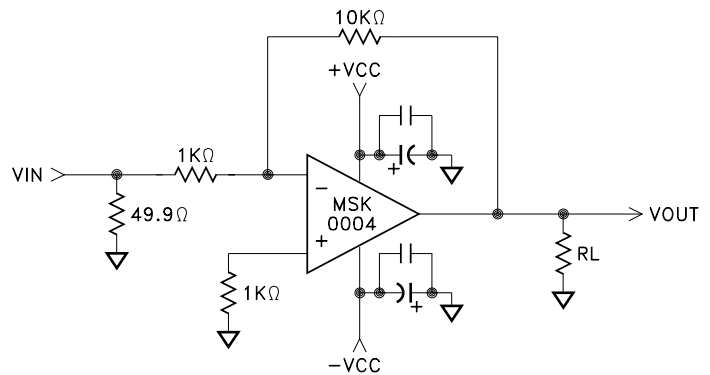

REPLACING THE LH0004

The MSK 0004 is not an exact copy of the LM0004 but it is only slightly different. The MSK 0004 is internally compensated and is lower cost. Pins 1,5,6,7 and 10 are not connected internally in the MSK0004.

TYPICAL PERFORMANCE CURVES

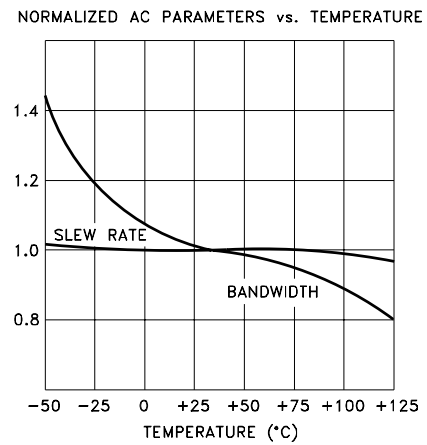
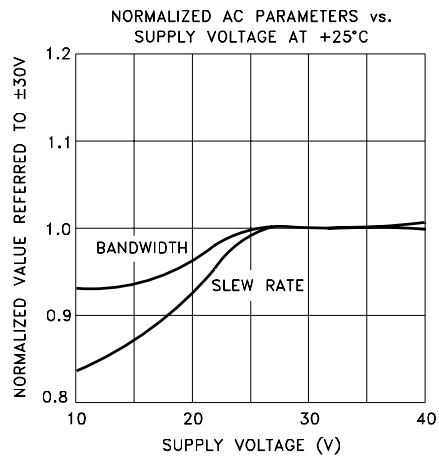
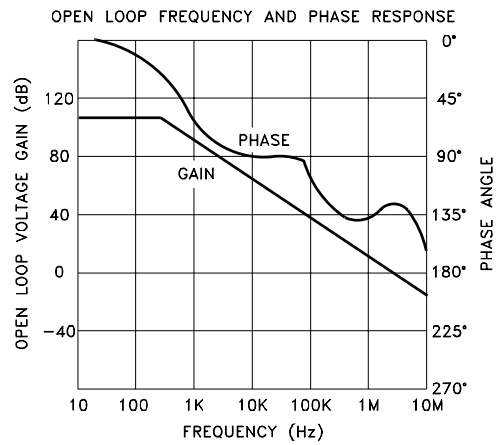
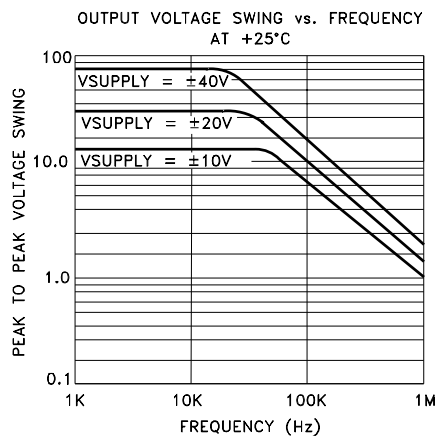
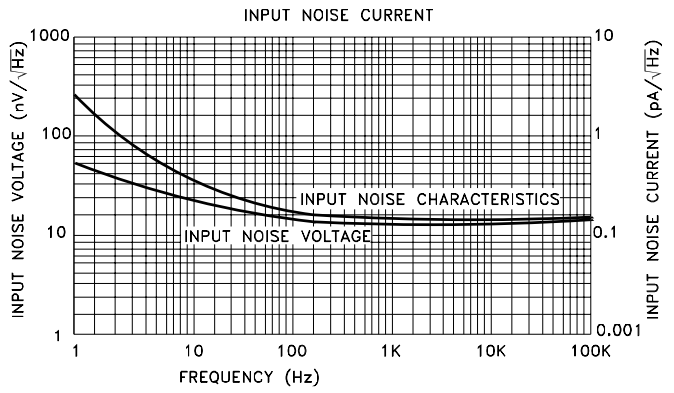
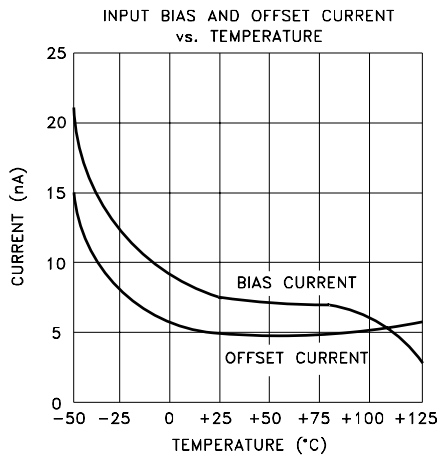

MECHANICAL SPECIFICATIONS

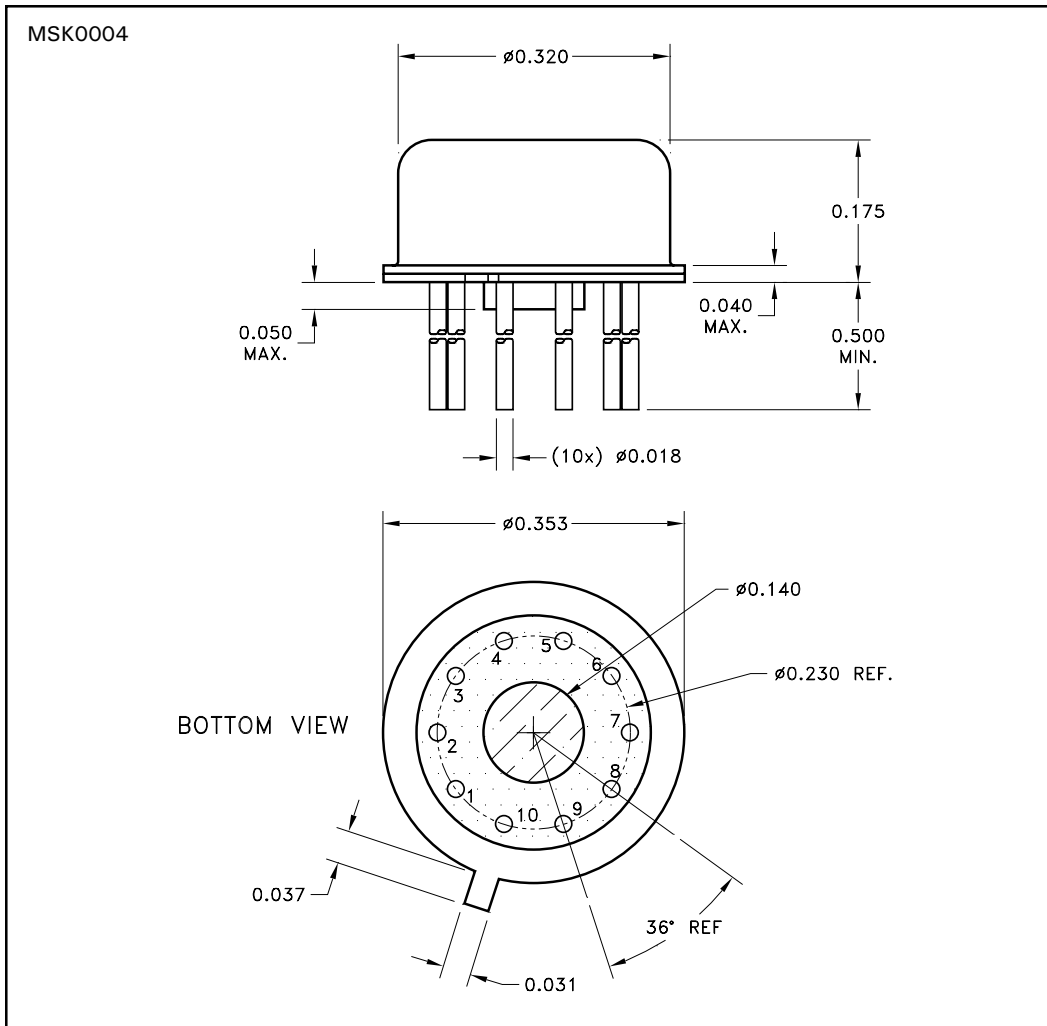

ALL DIMENSIONS ARE ± 0.010 INCHES UNLESS OTHERWISE LABELED.

ORDERING INFORMATION

MSK0004 H

SCREENING

BLANK = INDUSTRIAL; E = EXTENDED RELIABILITY

H = MIL-PRF-38534 CLASS H

GENERAL PART NUMBER

The above example is a Military grade hybrid.

M.S. Kennedy Corp.
 4707 Dey Road, Liverpool, New York 13088
 Phone (315) 701-6751
 FAX (315) 701-6752
 www.mskennedy.com

The information contained herein is believed to be accurate at the time of printing. MSK reserves the right to make changes to its products or specifications without notice, however, and assumes no liability for the use of its products. Please visit our website for the most recent revision of this datasheet.