



M.S.KENNEDY CORP.

**10 AMP, 600 VOLT IGBT
SMART POWER 3-PHASE
MOTOR DRIVE HYBRID**

4454

4707 Dey Road Liverpool, N.Y. 13088

(315) 701-6751

FEATURES:

- 600V, 10 Amp Capability
- Ultra Low Thermal Resistance - Junction to Case - 2.2°C/W (Each IGBT)
- Self-Contained, Smart Lowside/Highside Drive Circuitry
- Bootstrap High-Side Supplies
- Under-Voltage Lockout
- Capable of Switching Frequencies to 25KHz
- Isolated Case Allows Direct Heat Sinking
- Non-Hermetic Bolt-down Design Allows Superior Heat Dissipation

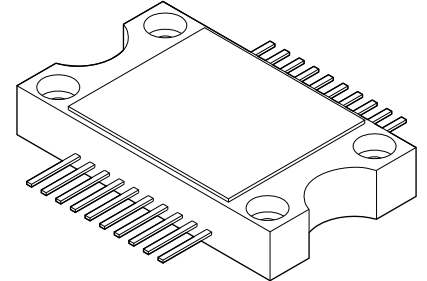

DESCRIPTION:

The MSK 4454 is a 10 Amp, 3 Phase Bridge Smart Power Motor Drive Hybrid with a 600 volt rating on the output switches. The output switches are Insulated Gate Bipolar Transistors (IGBT's). The free-wheeling diodes are Fast Recovery Epitaxial Diodes (FRED's) to provide matched current capabilities with the IGBT's and are specified with excellent reverse recovery times. This new smart power motor drive hybrid is 5.0 volt input logic compatible. Under-voltage lockout shuts down the bridge when the supply voltage gets to a point of incomplete turn-on of the output switches. The internal high-side bootstrap power supply derived from the +VB supply completely eliminates the need for 3 floating independent power supplies.

EQUIVALENT SCHEMATIC

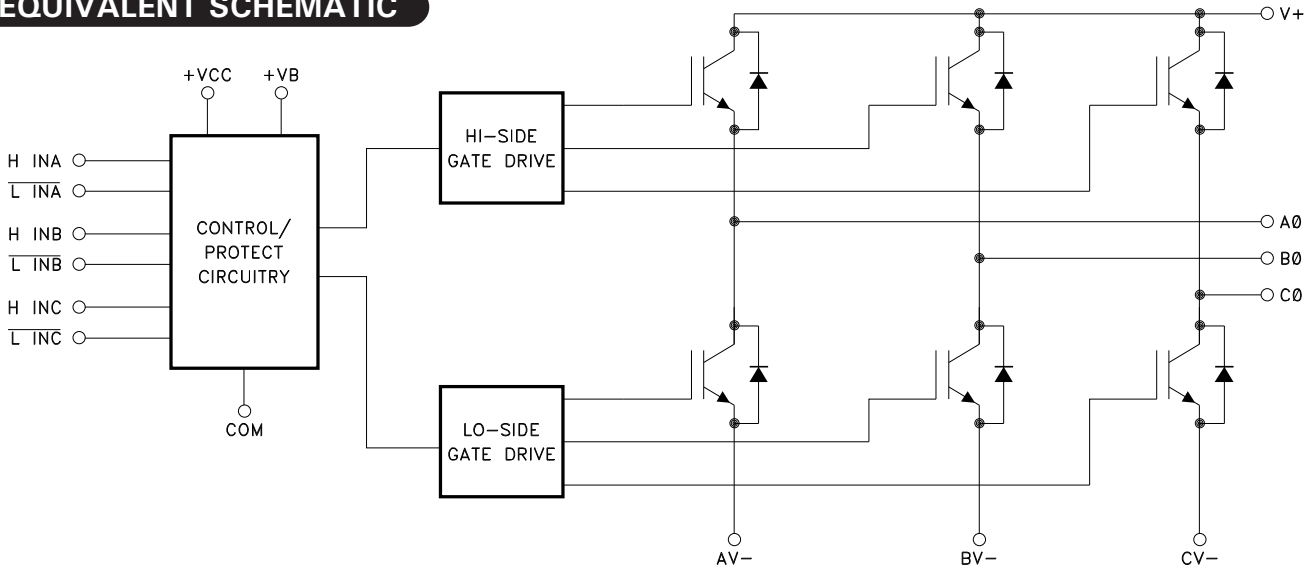

TYPICAL APPLICATIONS

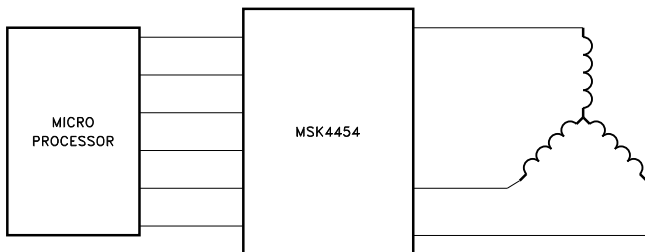

**3 PHASE SIX STEP DC BRUSHLESS MOTOR DRIVE
OR 3 PHASE SINUSOIDAL INDUCTION MOTOR DRIVE**

PIN-OUT INFORMATION

1 H INA	20 V +
2 L INA	19 N/C
3 +VCC	18 AV-
4 H INB	17 AØ
5 L INB	16 N/C
6 COM	15 BV-
7 COM	14 BØ
8 +VB	13 N/C
9 H INC	12 CV-
10 L INC	11 CØ

ABSOLUTE MAXIMUM RATINGS ④

V+	High Voltage Supply ⑤	600V	TsT	Storage Temperature Range	-55° to +125°C
VCC	Logic Supply	18V	TLD	Lead Temperature Range	
IOUT	Continuous Output Current	10A	TC	(10 Seconds)	300°C
IPK	Peak Output Current	30A		Case Operating Temperature	
θJC	Thermal Resistance @ 125°C (Output Switches)(Junction to Case)	2.2°C/W		MSK 4454	-40°C to +85°C
θJC	Thermal Resistance @ 125°C (Diodes)	2.7°C/W	TJ	Junction Temperature	+150°C

ELECTRICAL SPECIFICATIONS

Parameters	Test Conditions ②	MSK 4454			UNITS
		Min.	Typ.	Max.	
OUTPUT CHARACTERISTICS					
VC-E (On) Voltage (Each IGBT)	Ic = 10A	-	3.1	3.8	volts
Leakage Current (Each IGBT) ③	V+ = 600V	-	250	500	μA
Instantaneous Forward Voltage (FRED Flyback Diode) ③	Id = 10A	-	1.75	2.5	volts
Reverse Recovery Time	Id = 10A, di/dt = 100A/μS, Vr = 350V	-	-	180	nS
BIAS SUPPLY CHARACTERISTICS					
+VCC Bias Current	+VCC = 15V	-	-	6	mA
+VB Bias Current	+VB = 15V	-	-	1	mA
INPUT SIGNAL CHARACTERISTICS ①					
Positive Trigger Threshold Voltage	+VCC = 15V	2.7	-	-	volts
Negative Trigger Threshold Voltage	+VCC = 15V	-	-	0.8	volts
Under-voltage Lockout	+VCC Positive Going Threshold	7.2	8.9	10.8	volts
	+VCC Negative Going Threshold	6.7	8.2	9.9	volts
Dead Time	Low Side Turn-off to High Side Turn-On	280	400	520	nSEC
	High Side Turn-off to Low Side Turn-On	280	400	520	nSEC

NOTES:

- ① Guaranteed by design but not tested. Typical parameters are representative of actual device performance but are for reference only.
- ② VCC = +15V, VB = +15V, V+ = 270V and TCASE = 25°C unless otherwise specified.
- ③ Measured using a 300μS pulse with a 2% duty cycle.
- ④ Continuous operation at or above absolute maximum ratings may adversely effect the device performance and/or life cycle.
- ⑤ When applying power to the device, apply the low voltage followed by the high voltage or alternatively, apply both at the same time. Do not apply high voltage without low voltage present.

TYPICAL PERFORMANCE CURVES

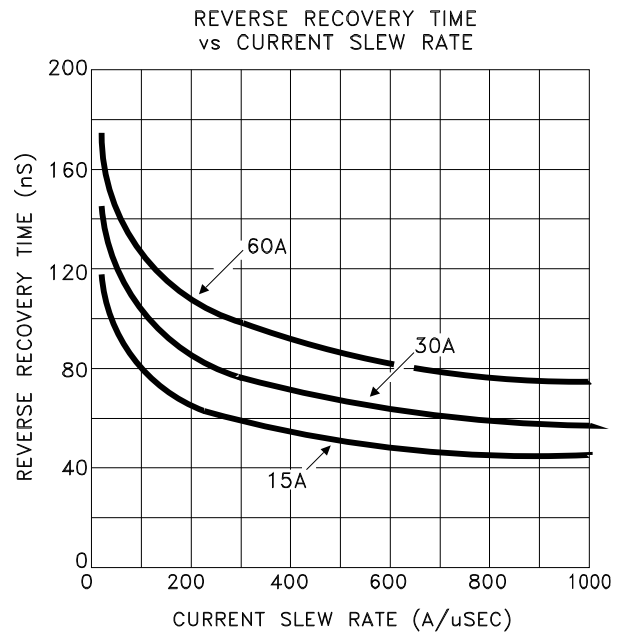
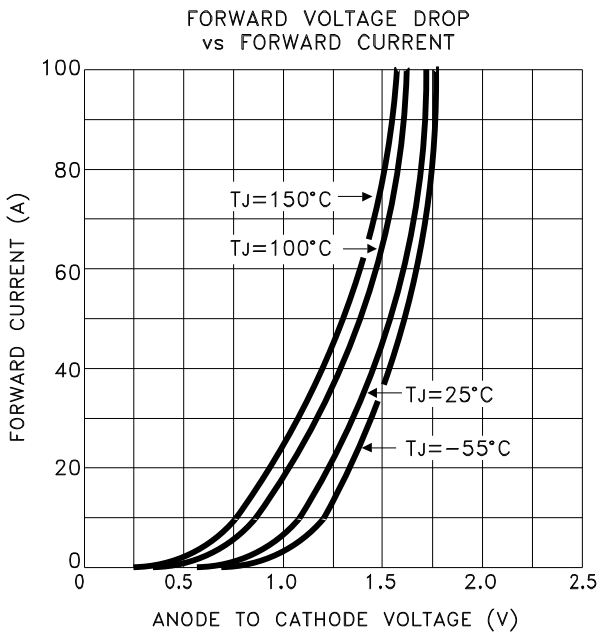
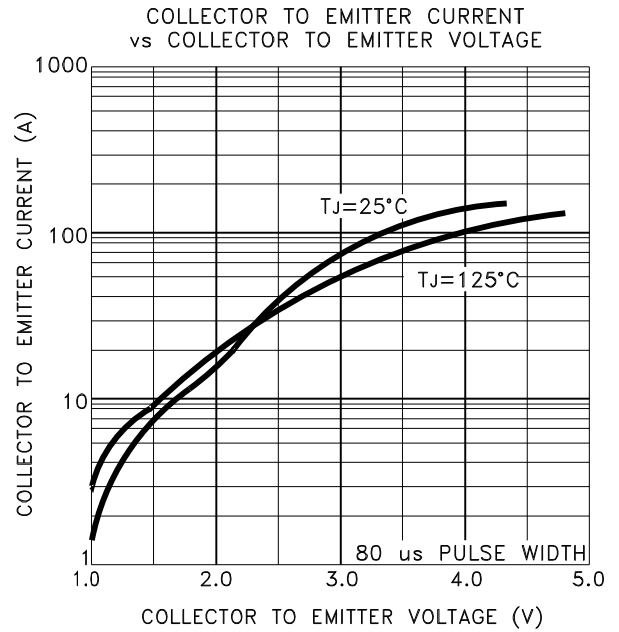
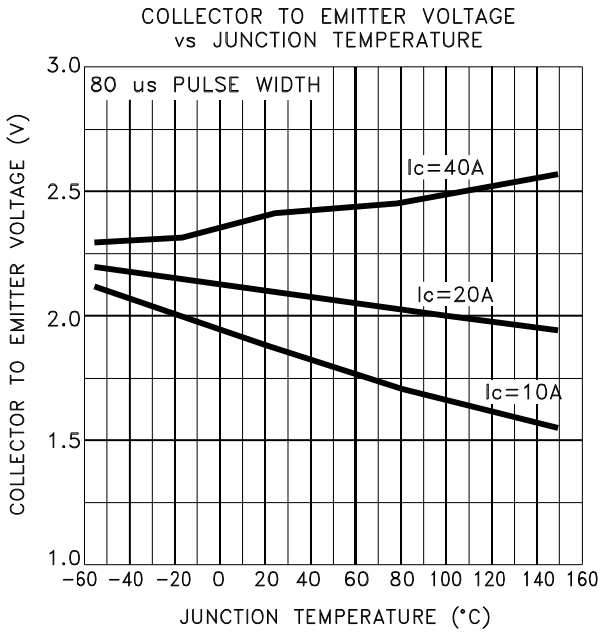

APPLICATION NOTES

MSK 4454 PIN DESCRIPTIONS

+VCC - Is the low voltage supply for all the internal logic and drivers. A 0.1 μ F ceramic capacitor in parallel with a 10 μ F tantalum capacitor is the recommended bypassing from the +VCC pin to the COM pin.

H INA, H INB, H INC - Are high active logic inputs for signalling the corresponding phase high-side switch to turn on. The logic inputs are compatible with standard CMOS or LSTTL outputs. These logic inputs are internally zener clamped at 5.2 volts.

L INA, L INB, L INC - Are low active logic inputs for signalling the corresponding phase low-side switch to turn on. The logic inputs are compatible with standard CMOS or LSTTL outputs. These logic numbers are internally zener clamped at 5.2 volts.

A \emptyset , B \emptyset , C \emptyset - Are the pins connecting the 3 phase bridge switch options.

AV-, BV-, CV- - Are the connections from the bottoms of the three half bridges. These pins get connected to the COM pin. If current sensing is desired they may be connected to the COM pin through a low value sense resistor.

+VB - Is the connection used to provide power to the floating high-side bootstrap supplies in the gate drive circuitry.

V+ - Is the high voltage positive rail connection to the tops of the three half bridges. Proper power supply bypassing must be connected from this pin to the COM pin for good filtering. This bypassing must be done as close to the hybrid as possible.

COM - Is the connection that all hybrid power supply connections are returned to and bypassed to.

TYPICAL SYSTEM OPERATION

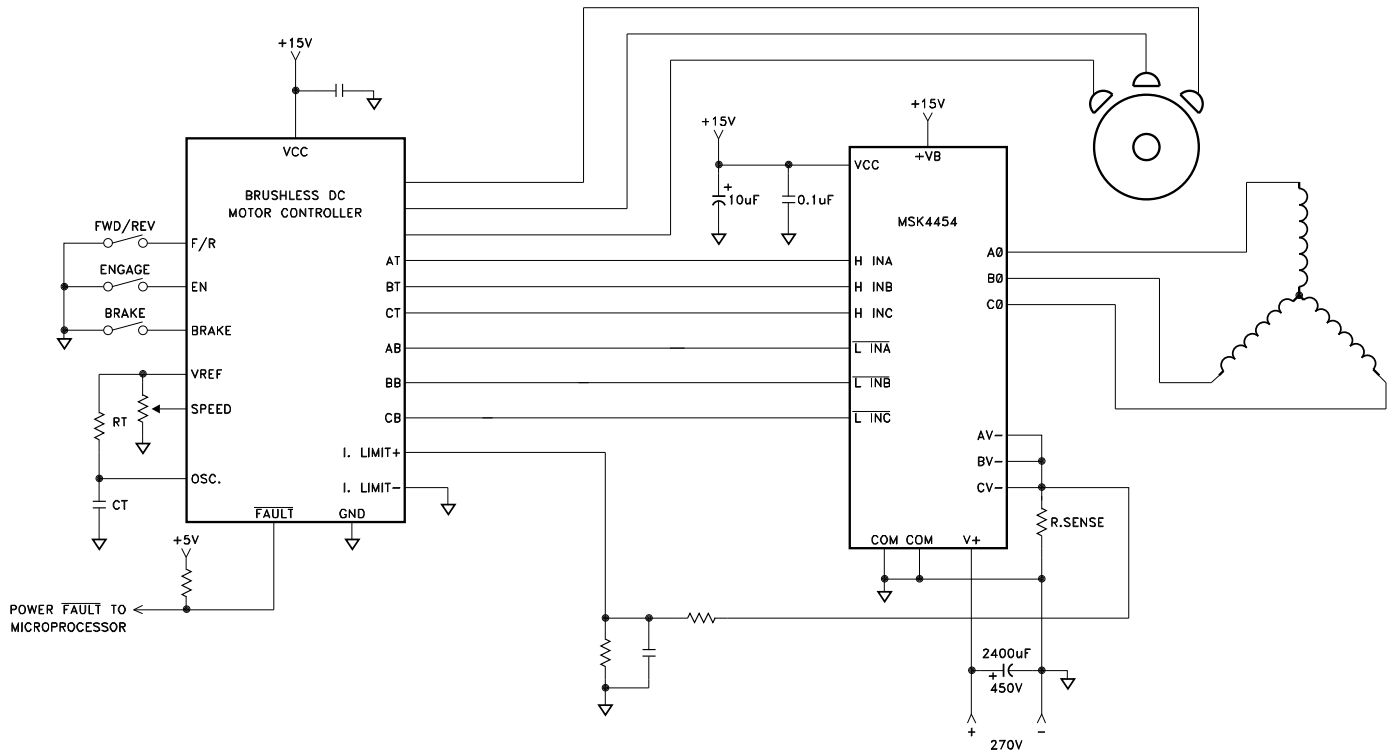

The MSK 4454 is designed to be used with a +270 volt high voltage bus, +15 volt low power bus and +5 volt logic signals. Proper derating should be applied when designing the MSK 4454 into a system. High frequency layout techniques with ground planes on a printed circuit board is the only method that should be used for circuit construction. This will prevent pulse jitter caused by excessive noise pickup on the current sense signal or the error amp signal.

Ground planes for the lower power circuitry and the high power circuitry should be kept separate. The connection between the bottom of the current sense resistor, COM pin and the high power ground, AV-, BV- and CV- pins are connected at this point. This is a critical path and high currents should not be flowing between the current sense and COM. Inductance in this path should be kept to a minimum. An RC filter (shown in 2 places) will filter out the current spikes and keep the detected noise for those circuits down to a minimum.

In the system shown a PWM pulse by pulse current limit scheme controlled by the motor controller is implemented.

When controlling the motor speed by the PWM method, it is required that the low side switches be PWM pulsed due to the bootstrap supplies used to power the high side switch drives. The higher the PWM speed the higher the current load on the drive supply. PWM of the low side will prevent sagging of the high side supplies. A separate pin (+VB) is provided for connecting an external floating power supply to power the bootstrap supplies.

MECHANICAL SPECIFICATIONS

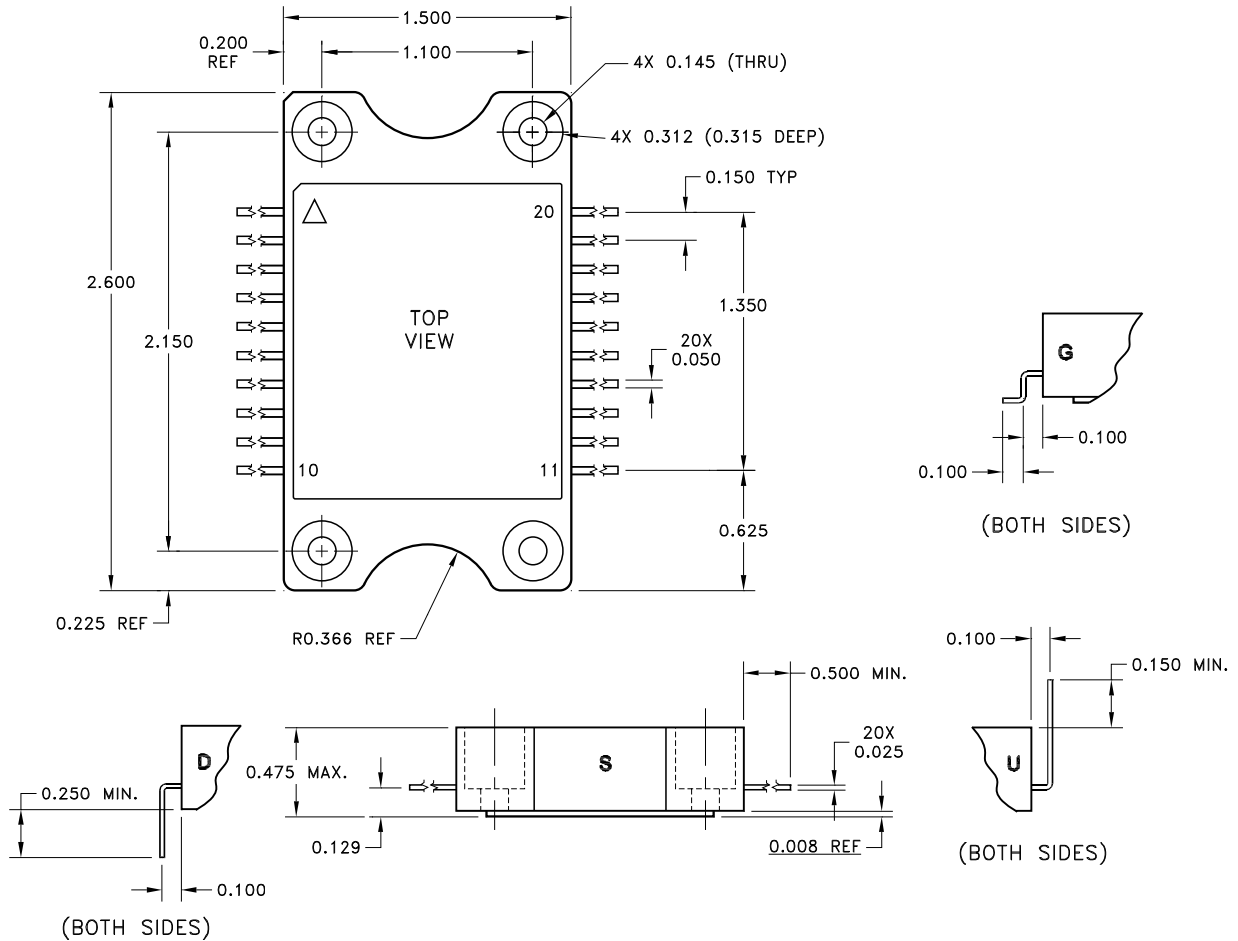

WEIGHT = 32.2 GRAMS TYPICAL
ESD Triangle Indicates Pin 1.

NOTE: ALL DIMENSIONS ARE ± 0.010 UNLESS OTHERWISE LABELED.

CAUTION: THIS IS A NON-HERMETIC DEVICE. DO NOT EXPOSE PLASTIC HOUSING TO LIQUID

ORDERING INFORMATION

Part Number	Screening Level	Lead Configuration
MSK4454S	Industrial	Straight
MSK4454D	Industrial	Down
MSK4454U	Industrial	Up
MSK4454G	Industrial	Gull Wing

M.S. Kennedy Corp.
4704 Dey Road, Liverpool, New York 13088
Phone (315) 701-6751
FAX (315) 701-6752
www.mskennedy.com

The information contained herein is believed to be accurate at the time of printing. MSK reserves the right to make changes to its products or specifications without notice, however, and assumes no liability for the use of its products. Please visit our website for the most recent revision of this datasheet.