



M.S.KENNEDY CORP.

# WIDE BANDWIDTH, VERY HIGH VOLTAGE CRT VIDEO AMPLIFIER

# 643

4707 Dey Road Liverpool, N.Y. 13088

(315) 701-6751

**FEATURES:**

- Negative Output Voltage for Grid Drive
- 2.5nS Transition Times
- Drives 8.5pF Capacitive Load With Ease
- DC Coupled for Output Level Adjust
- 175MHz Bandwidth
- 70Vpp Output Swing
- Replacement for CR3424R
- Contact MSK for MIL-PRF-38534 for Qualification Status

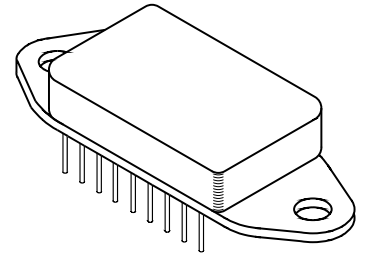

**DESCRIPTION:**

The MSK 643 is a wide bandwidth, high voltage color or monochrome CRT video amplifier designed specifically to drive the grid of today's most demanding high resolution CRT monitors. The MSK 643 is a transimpedance amplifier capable of achieving a  $\pm 35V$  output voltage swing with an input current of  $\pm 10mA$ . The output of the amplifier is DC biased at half the power supply voltage. Transition times in the range of 2.5nS enable the MSK 643 to drive 10nS pixels with ease and make it ideally suited for monitors with 1280 x 1024 or higher display resolutions. The MSK 643 is mounted in a space efficient 9 pin single in-line bathtub package with two mounting tabs for direct mounting to a heat sink or chassis.

**EQUIVALENT SCHEMATIC**

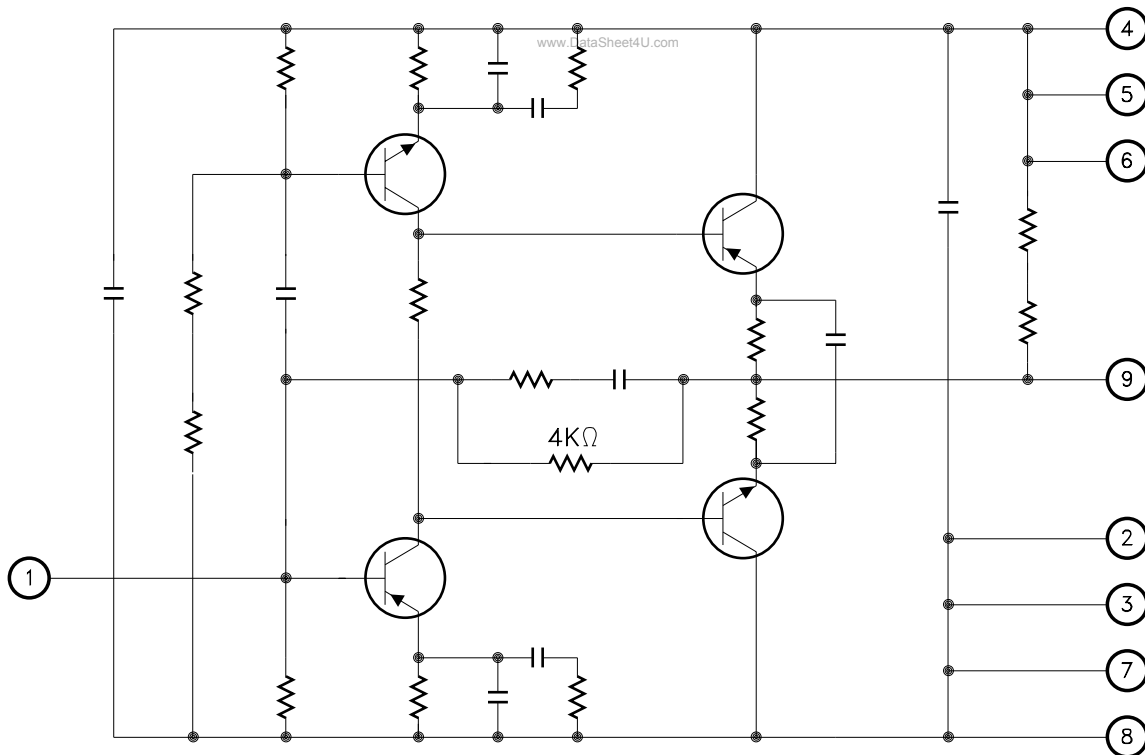

**TYPICAL APPLICATIONS**

- CRT Driver for Color and Monochrome Monitors
- High Voltage Transimpedance Amplifier
- Ultra High Speed Amplifier for Test Equipment

**PIN-OUT INFORMATION**

1 Inverting Input	6 -Vee
2 Ground	7 Ground
3 Ground	8 Ground
4 -Vee	9 Output
5 -Vee	

## ABSOLUTE MAXIMUM RATINGS <sup>⑦</sup>

$-V_{EE}$	Supply Voltage . . . . .	-85V	$T_{ST}$	Storage Temperature Range	-65°C to +150°C
$\theta_{JC}$	Thermal Resistance . . . . . (Junction to Case)	27°C/W	$T_{LD}$	Lead Temperature Range . . . . . (10 Seconds)	300°C
$I_{OUT}$	Peak Output Current . . . . .	250mA	$T_C$	Case Operating Temperature MSK643 . . . . .	-40°C to +85°C
				MSK643G . . . . .	-55°C to +85°C
			$T_J$	Junction Temperature . . . . .	175°C

## ELECTRICAL SPECIFICATIONS

-Vee = -80V Unless Otherwise Specified

Parameter	Test Conditions <sup>①</sup>	Group A Subgroup	MSK 643G			MSK 643			Units
			Min.	Typ.	Max.	Min.	Typ.	Max.	
<b>STATIC</b>									
Power Supply Current	$V_{IN} = N/C$	1	-	-40	-45	-	-40	-50	mA
		2	-	-55	-65	-	-55	-	mA
		3	-	-35	-45	-	-35	-	mA
Input Bias Voltage	$V_{IN} = N/C$	1	-1.4	-1.55	-1.7	-1.3	-1.55	-1.8	V
		2,3	-1.35	-	-1.8	-	-	-	V
Output Offset Voltage	$V_{IN} = N/C$	1	-38	-40	-42	-37	-40	-43	V
		2,3	-36	-40	-44	-	-	-	V
Input Capacitance <sup>②</sup>	$V_{IN} = 0.7V$	-	-	10	-	-	10	-	pF
Power Supply Range	Derated Performance	-	-60	-80	-85	-60	-80	-85	V
<b>DYNAMIC CHARACTERISTICS</b>									
Output Voltage High	$f = 10KHz$	4	-74	-76	-	-74	-76	-	V
Output Voltage Low	$f = 10KHz$	4	-	-4	-6	-	-4	-6	V
Voltage Gain	$V_{IN} = 2V_{PP}; f = 10KHz$	4	10.5	12.5	14.5	10	12.5	15	V/V
Rise Time	$V_{OUT} = 40V_{PP}$	4	-	2.5	3.4	-	2.5	3.5	nS
Fall Time	$V_{OUT} = 40V_{PP}$	4	-	2.5	3.4	-	2.5	3.5	nS
Overshoot (Adjustable) <sup>②</sup>	$V_{OUT} = 20V_{PP}$	-	-	25	-	-	25	-	%
-3dB Bandwidth <sup>②</sup>	$V_{OUT} = 20V_{PP}$	-	125	175	-	120	175	-	MHz
Low Frequency Tilt Voltage <sup>②</sup>	$f = 1KHz$	-	-	-	1.5	-	-	1.5	V
Linearity Error	$f = 10KHz; 5V_{PP} \leq V_{OUT} \leq 50V_{pp}$	4	-	0.5	5	-	0.5	5	%

### NOTES:

- ①  $R_{IN} = 300\Omega$ ,  $C_{IN} = 100pF$ ,  $C_{LOAD} = 8.5pF$ ,  $R_L = \infty$ , unless otherwise specified (See Figure 1).
- ② Guaranteed by design but not tested. Typical parameters are representative of actual device performance but are for reference only.
- ③ Industrial grade devices shall be tested to subgroups 1 and 4 unless otherwise specified.
- ④ Military grade devices ('G' suffix) shall be 100% tested to subgroups 1,2,3 and 4.
- ⑤ Subgroup 5 and 6 testing available upon request.
- ⑥ Subgroup 1,4  $T_A = T_C = +25^\circ C$   
Subgroup 2,5  $T_A = T_C = +85^\circ C$   
Subgroup 3,6  $T_A = T_C = -55^\circ C$
- ⑦ Continuous operation at or above absolute maximum ratings may adversely effect the device performance and/or life cycle.

## APPLICATION NOTES

### TYPICAL TEST CIRCUIT

The signal source in Figure 1 can be either a fast pulse generator or a network analyzer as long as the output impedance is 50 ohms. The DC level of the input should be -1.55V and all cables should be kept as short as possible. Since total load capacitance should be kept below 8.5pF, a FET probe should be used on the output.

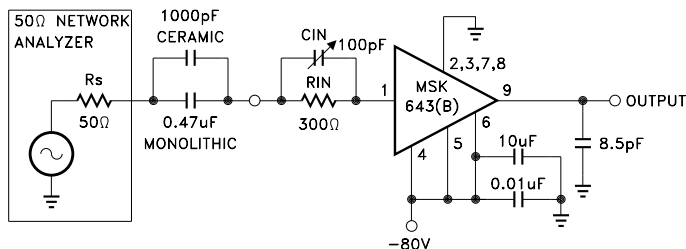

FIGURE 1

### USING THE MSK 643

The output of the amplifier is biased at one half of the power supply voltage. An output voltage swing of  $\pm 35$  volts is typical with a power supply voltage of -80 volts. With an 8.5pF capacitive load, transition times are in the 2.5nS range. If a spark gap current limiting resistor is used on the output of the amplifier and the transition times are degraded, a peaking coil may be used to preserve system performance. The optimum value for this coil will be in the range of 100 to 200nH and can be determined by trial and error. The output of the MSK 643 is not short circuit protected, therefore, purely resistive loads should be no less than 800 ohms at any time to avoid damaging the output.

### OPERATION CONSIDERATIONS

The input of the MSK 643 rests at a -1.55VDC level with the input terminal open. In this state, the output rests at one half of the power supply voltage. When connecting a pulse generator to the input of the amplifier, the DC level should be offset so that the signal is centered around -1.55V. During characterization, the input should be coupled to the MSK 643 through a parallel combination of a variable resistor and variable capacitor peaking circuit. Optimum values for the peaking circuit can be determined experimentally. The optimum value of load capacitance is 8.5pF. Viewing the output with a normal oscilloscope probe would seriously degrade performance. A FET probe fitted with a 100:1 voltage divider will add only approximately 1.5pF of capacitance to the load and is highly recommended. An experimental circuit along with recommended values can be found in Figure 2.

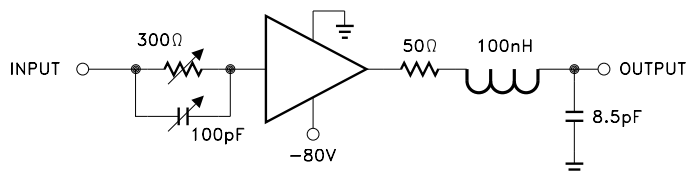

FIGURE 2

### OUTPUT ISSUES

The output of the MSK 643 is a pair of bipolar emitter followers configured in a complimentary push pull configuration. This configuration eliminates the need for a pull up load resistor and makes the amplifier less susceptible to load capacitance variations. Connecting a wire or cable from the output of the amplifier to the CRT grid can create a resonant circuit which can cause unwanted oscillations or overshoot at its resonant frequency. A damping resistor in series with the lead inductance will alleviate this condition. The optimum value of this resistor can be determined using the following formula:

$$R = 2 * \sqrt{L/C}$$

This resistor also doubles as an arcing protector. In the breadboarding stage, the value of this resistor should be determined experimentally. Resistance in the range of 50 to 100 ohms is usually sufficient. If a quick, simple peaking network is desired, a 300 ohm cable terminated by a capacitor will act like an inductor in the frequency range involved.

### TRANSIMPEDANCE AMPLIFICATION

Transimpedance amplifiers relate input current to output voltage. The MSK 643 contains an internal 4K $\Omega$  feedback resistor. This resistor converts input current to output voltage in the following manner (See Figure 1):

$\pm 1.43$ V (referenced to -1.55Vdc) across the 300 $\Omega$  input resistor results in an input current of  $\pm 4.77$ mA. This current flows through the 4K $\Omega$  feedback resistor and results approximately in a  $\pm 20$ V swing at the output. The actual voltage gain of the typical MSK 643 circuit may be slightly less due to transistor losses. The following formula approximates voltage gain including potential losses:

$$\text{Voltage Gain (V/V)} = 4K\Omega / (R_{in} + L) \quad L \approx 25\Omega$$

### HEAT SINKING

The MSK 643 requires heat sinking in most applications. The following formula may be applied to determine if a heat sink is necessary and what size and type to use.

$$R_{\theta sa} = ((T_j - T_a) / P_d) - (R_{\theta jc}) - (R_{\theta cs})$$

#### WHERE

- T<sub>j</sub> = Junction Temperature
- P<sub>d</sub> = Total power dissipation
- R <sub>$\theta$  jc</sub> = Junction to case thermal resistance
- R <sub>$\theta$  cs</sub> = Case to heat sink thermal resistance
- R <sub>$\theta$  sa</sub> = Heat sink to ambient thermal resistance
- T<sub>c</sub> = Case temperature
- T<sub>a</sub> = Ambient temperature
- T<sub>s</sub> = Sink temperature

#### EXAMPLE

- T<sub>j</sub> = 150°C
- T<sub>a</sub> = 85°C
- P<sub>d</sub> = 1.5W
- R <sub>$\theta$  jc</sub> = 27°C/W
- R <sub>$\theta$  cs</sub> = 0.15°C/W

Solving the above equation for R <sub>$\theta$  sa</sub> (heat sink thermal conductivity) shows that the heat sink for this application must have a thermal resistance of no more than 16°C/W to maintain a junction temperature of no more than 150°C.

# TYPICAL PERFORMANCE CURVES

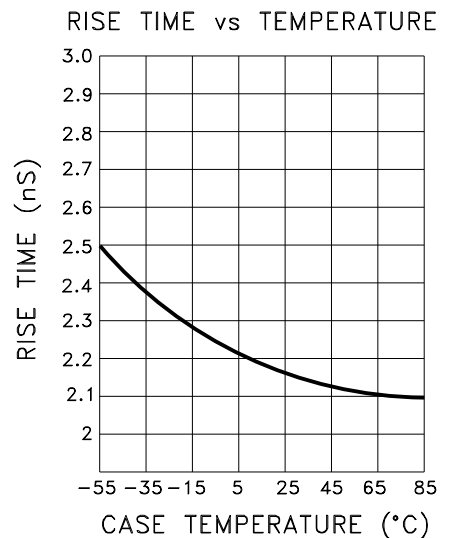
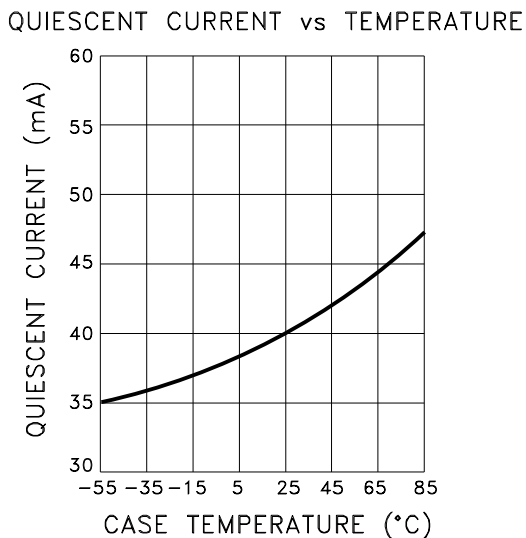
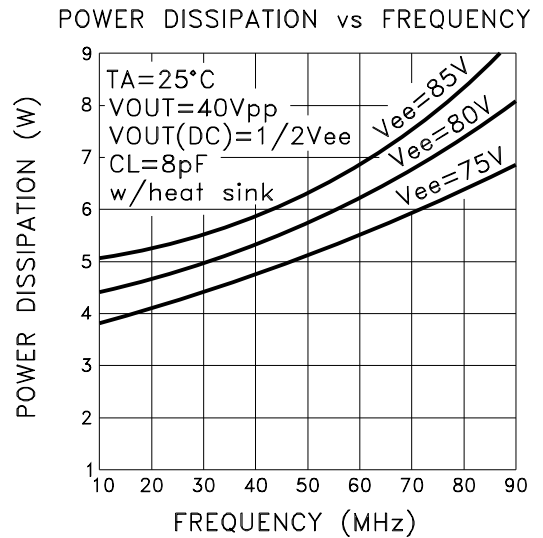
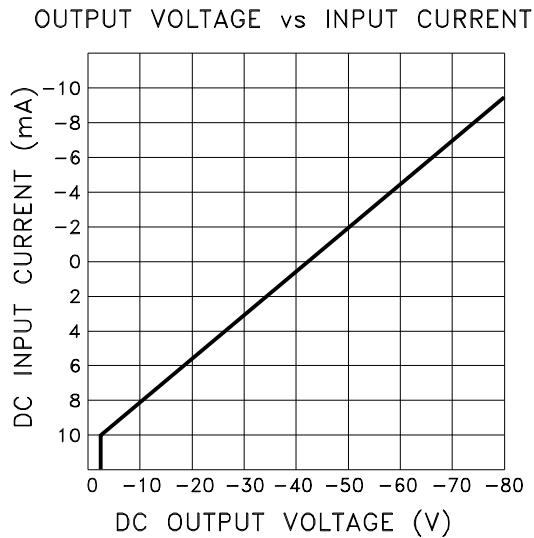
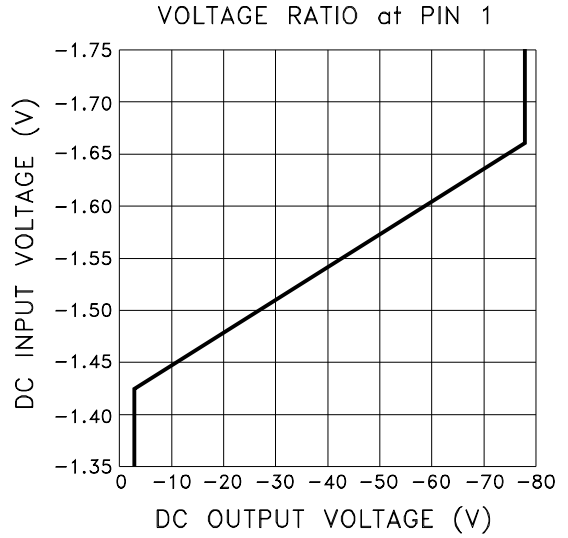
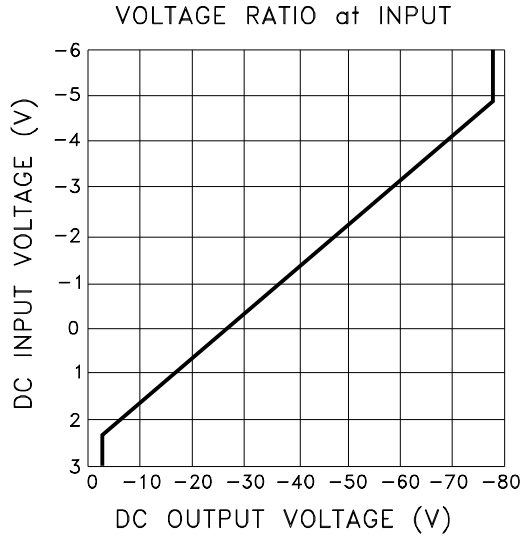

# COMPLETE VIDEO SYSTEM

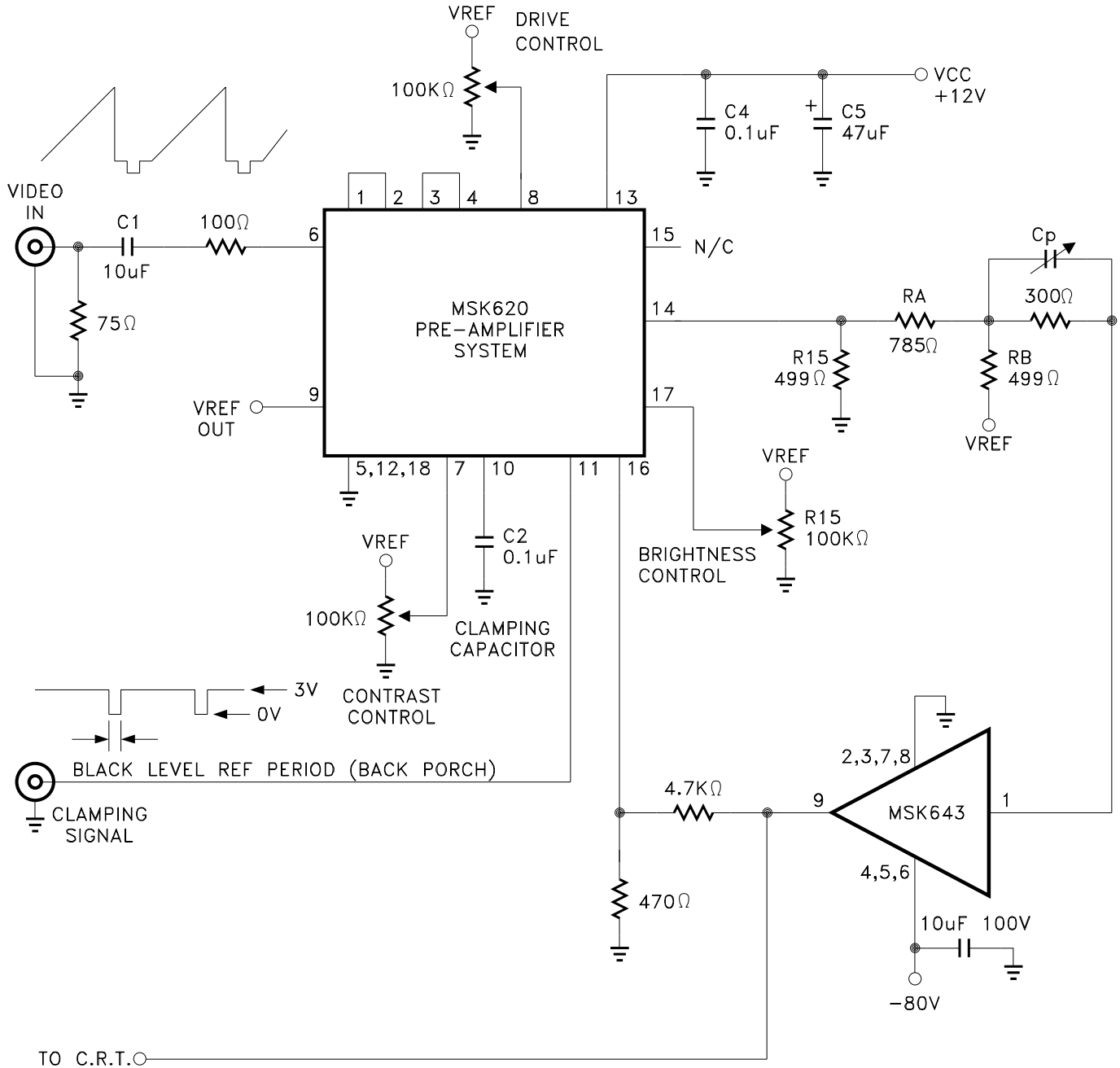
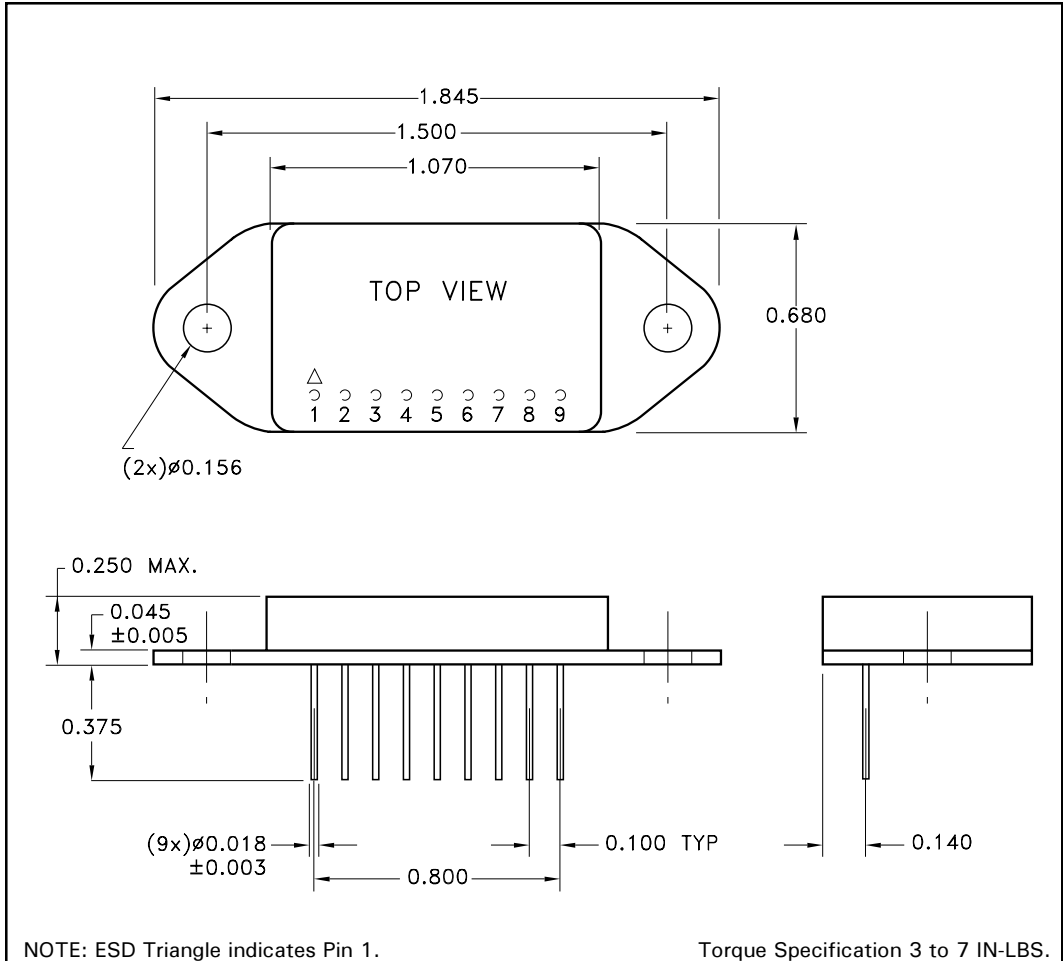

FIGURE 3

Figure 3 above illustrates how an MSK 620 and MSK 643 can be used to build a complete video system for high voltage grid drive. RA and RB act as a level shift stage to match the +3.9Vdc level at the output of the MSK 620 with the -1.55Vdc level at the input of the MSK 643. The output of the MSK 643 is sampled and fed back to the MSK 620. This scheme provides black level control superior to sampling the signal at pin 14 of the MSK 620. The general rule of thumb for transition times for a video driver is that rising and falling edges should be no more than one third the pixel time of the monitor. To improve rise and fall time in the system, the peaking capacitor Cp was added across the input resistor of the MSK 643. At high frequencies Cp increases the gain of the amplifier there by causing peaking. Cp should be a variable capacitor so that the response of the amplifier can be fine tuned for minimum transition time with minimum overshoot.

# MECHANICAL SPECIFICATIONS



NOTE: ESD Triangle indicates Pin 1. Torque Specification 3 to 7 IN-LBS.  
 ALL DIMENSIONS ARE  $\pm 0.010$  INCHES UNLESS OTHERWISE LABELED

## ORDERING INFORMATION

Part Number	Screening Level
MSK643	Industrial
MSK643G	Mil-PRF-38534 Class G

M.S. Kennedy Corp.  
 4707 Dey Road, Liverpool, New York 13088  
 Phone (315) 701-6751  
 FAX (315) 701-6752  
 www.mskennedy.com

The information contained herein is believed to be accurate at the time of printing. MSK reserves the right to make changes to its products or specifications without notice, however, and assumes no liability for the use of its products. Please visit our website for the most recent revision of this datasheet. Contact MSK for MIL-PRF-38534 qualification status.