

SIDE LOOK PACKAGE SOLID STATE LAMP

MSL-854HG

Description

The MSL-854HG is designed based on an industry standard package for ease of handling and use. The package is water clear epoxy within white plastic.

Package Dimensions

Units : mm

Applications

- LCD backlighting
- Symbol backlighting
- Front panel indicator

Features

- High performance
- Excellent chip to chip consistency
- High reliability

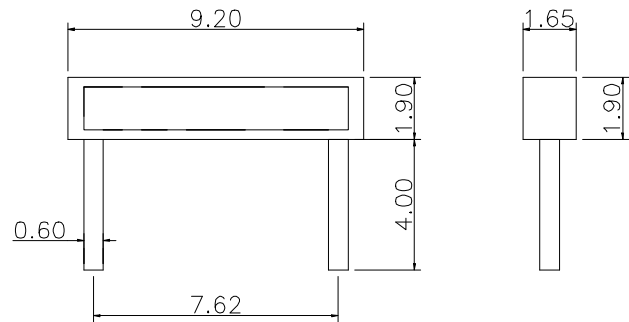

ANODE CATHODE

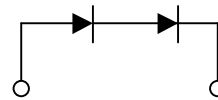

Notes :

1. All dimensions are in millimeters.
2. Tolerance is ± 0.25 mm unless otherwise noted.

Absolute Maximum Ratings

'@ $T_A=25^\circ\text{C}$

Parameter	Symbol	Maximum Rating	Unit
Power Dissipation	P_{ad}	200	mW
Continuous Forward Current	I_{af}	30	mA
Reverse Current($V_R=5V$)	I_R	10	μA
Operating Temperature Range	T_{opr}	-40°C to +85°C	
Storage Temperature Range	T_{stg}	-40°C to +85°C	
Lead Soldering Temperature 260°C for 5 second (2.0mm From Body)			

UNI

Unity Opto Technology Co., Ltd.

11/06/2000

Optical-Electrical Characteristics

@ T_A=25°C

PART NO	Color		Dominant Wave Length $\lambda_D(\text{nm})$	Spectral Halfwidth $\Delta\lambda(\text{nm})$	Forward Voltage @ I _F =20mA (V)		Luminous Intensity @ I _F =20mA (mcd)		Viewing Angle $2\theta_{1/2}$ (deg)
	Emitted	Lens			TYP	MAX	MIN	TYP	
MSL-854HG	Green	Water Clear	570	15	4.4	5	60	90	110

Typical Optical-Electrical Characteristic Curves

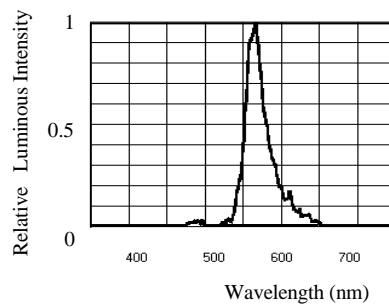

FIG.1 RELATIVE LUMINOUS INTENSITY VS. WAVELENGTH

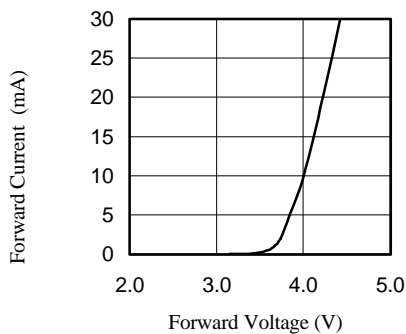

FIG.2 FORWARD CURRENT VS. FORWARD VOLTAGE

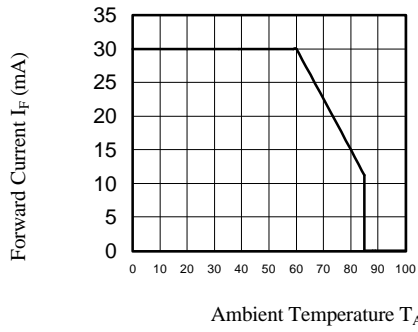

FIG.3 FORWARD CURRENT VS. AMBIENT TEMPERATURE

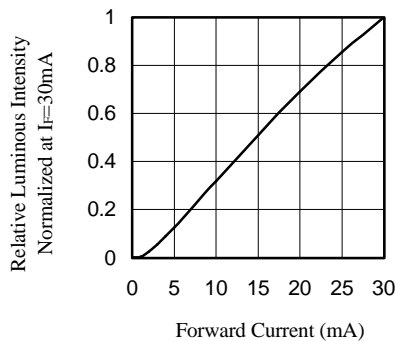

FIG.4 RELATIVE LUMINOUS INTENSITY VS. FORWARD CURRENT

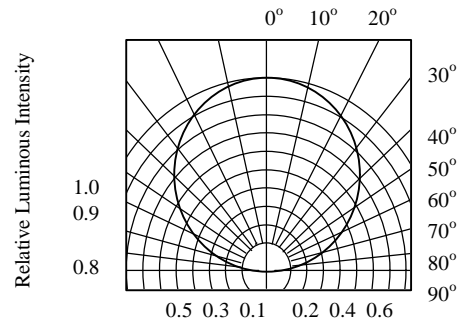

FIG.5 RADIATION PATTERN DIAGRAM