

MSP432P411x, MSP432P401x SimpleLink™ Mixed-Signal Microcontrollers

1 Device Overview

1.1 Features

- Core
 - Arm® 32-bit Cortex®-M4F CPU with floating point unit and memory protection unit
 - Frequency up to 48 MHz
 - ULP benchmark
 - 150.6 ULPBench™-CP Performance benchmark
 - 3.41 CoreMark/MHz
 - 1.22 DMIPS/MHz (Dhrystone 2.1)
- Advanced low-power analog features
 - SAR analog-to-digital converter (ADC) with 16-bit precision and up to 1 Msps
 - Differential and single-ended inputs
 - Two window comparators
 - Up to 24 input channels
 - Internal voltage reference with 25-ppm/°C typical stability
 - Two analog comparators
 - Integrated LCD driver with contrast control for up to 320 segments
- Memories
 - Up to 2048KB of flash main memory (organized into two banks enabling simultaneous read or execute during erase)
 - 32KB of flash information memory (including area used for BSL, TLV, and flash mailbox)
 - Up to 256KB of SRAM (including 8KB of backup memory)
 - 2KB of utility SRAM
 - 32KB of ROM with MSP432™ peripheral driver libraries
- Ultra-low-power operating modes
 - Active: 100 µA/MHz
 - Low-frequency active: 95 µA (at 128 kHz)
 - LPM3 (With RTC): 820 nA
 - LPM3.5 (With RTC): 820 nA
 - LPM4: 690 nA
 - LPM4.5: 22 nA
- SimpleLink™ platform
 - Support for *Bluetooth*® low energy, Wi-Fi®, and Sub-1 GHz
 - Single development environment
 - 100% code reuse across SimpleLink SDK
- Operating characteristics
 - Wide supply voltage range: 1.62 V to 3.7 V
 - Temperature range (ambient): –40°C to 85°C
- Flexible clocking features
 - Programmable internal DCO (up to 48 MHz)
 - 32.768-kHz low-frequency crystal (LFXT)
 - High-frequency crystal (HFXT) up to 48 MHz
 - Low-frequency trimmed internal reference oscillator (REFO)
 - Very-low-power low-frequency internal oscillator (VLO)
 - Module oscillator (MODOSC)
 - System oscillator (SYSOSC)
- Code security features
 - JTAG and SWD lock
 - IP protection (up to four secure flash zones, each with configurable start address and size)
- Enhanced system options
 - Programmable supervision and monitoring of supply voltage
 - Multiple-class resets for better control of application and debug
 - 8-channel DMA
 - RTC with calendar and alarm functions
- Timing and control
 - Up to four 16-bit timers, each with up to five capture, compare, pwm capability
 - Two 32-bit timers with interrupt generation capability
- Serial communication
 - Up to four eUSCI_A modules
 - UART with automatic baud-rate detection
 - IrDA encode and decode
 - SPI (up to 16 Mbps)
 - Up to four eUSCI_B Modules
 - I²C (with multiple-slave addressing)
 - SPI (up to 16 Mbps)
- Flexible I/O features
 - Ultra-low-leakage I/Os (±20 nA maximum)
 - All I/Os with capacitive touch capability
 - Up to 48 I/Os with interrupt and wake-up capability
 - Up to 24 I/Os with port mapping capability
 - Eight I/Os with glitch filtering capability
- Encryption and data integrity accelerators
 - 128-, 192-, or 256-bit AES encryption and decryption accelerator
 - 32-bit hardware CRC engine



- JTAG and debug support
 - 4-pin JTAG and 2-pin SWD debug interfaces
- Serial wire trace
- Power debug and profiling of applications

1.2 Applications

- Metering
 - Flow meter
 - Electric meters
 - Fault detectors
 - Field transmitters
- Building automation
 - Thermostat
 - Security systems
 - Smoke detectors
 - Access panels
- Factory automation
 - Wireless power monitor
 - Predictive failure sensors
 - Field transmitter
 - Foundational field bus
- Health and fitness
 - Health monitors
 - Fitness accessories
 - Blood glucose meters

1.3 Description

The SimpleLink MSP432P411x and MSP432P401x microcontrollers (MCUs) are optimized wireless host MCUs with an integrated 16-bit precision ADC, delivering ultra-low-power performance including 100 μ A/MHz in active power and 820 nA in standby power with FPU and DSP extensions. As an optimized wireless host MCU, the MSP432P411x and MSP432P401x let developers add high-precision analog and memory extension to applications based on [SimpleLink wireless connectivity solutions](#).

The MSP432P411x and MSP432P401x devices are part of the SimpleLink MCU platform, which consists of Wi-Fi, *Bluetooth* low energy, Sub-1 GHz, and host MCUs. All share a common, easy-to-use development environment with one core software development kit (SDK) and a rich tool set. A one-time integration of the SimpleLink platform lets you add any combination of devices from the portfolio into your design. The ultimate goal of the SimpleLink platform is to achieve 100 percent code reuse when your design requirements change. For more information, visit www.ti.com/simplelink.

MSP432P411x and MSP432P401x MCUs are supported by a comprehensive ecosystem of tools, software, documentation, training, and support to get your development started quickly. The LaunchPad™ development kit or MSP-TS432PZ100 target socket board (with additional MCU sample) along with the free SimpleLink MSP432 SDK are all you need to get started.

Device Information ⁽¹⁾

PART NUMBER	PACKAGE	BODY SIZE ⁽²⁾
MSP432P4111PZ MSP432P411YPZ MSP432P411VPZ	LQFP (100)	14 mm x 14 mm
MSP432P4011RGC MSP432P401YRGC MSP432P401VRGC	VQFN (64)	9 mm x 9 mm

- (1) For the most current part, package, and ordering information for all available devices, see the *Package Option Addendum* in [Section 9](#), or see the TI website at www.ti.com.
- (2) The sizes shown here are approximations. For the package dimensions with tolerances, see the *Mechanical Data* in [Section 9](#).

1.4 Functional Block Diagrams

Figure 1-1 and Figure 1-2 show the functional block diagrams of the MSP432P411x and MSP432P401x devices, respectively.

The CPU and all of the peripherals in the device interact with each other through a common AHB matrix. In some cases, there are bridges between the AHB ports and the peripherals. These bridges are transparent to the application from a memory map perspective and, therefore, are not shown in the block diagram.

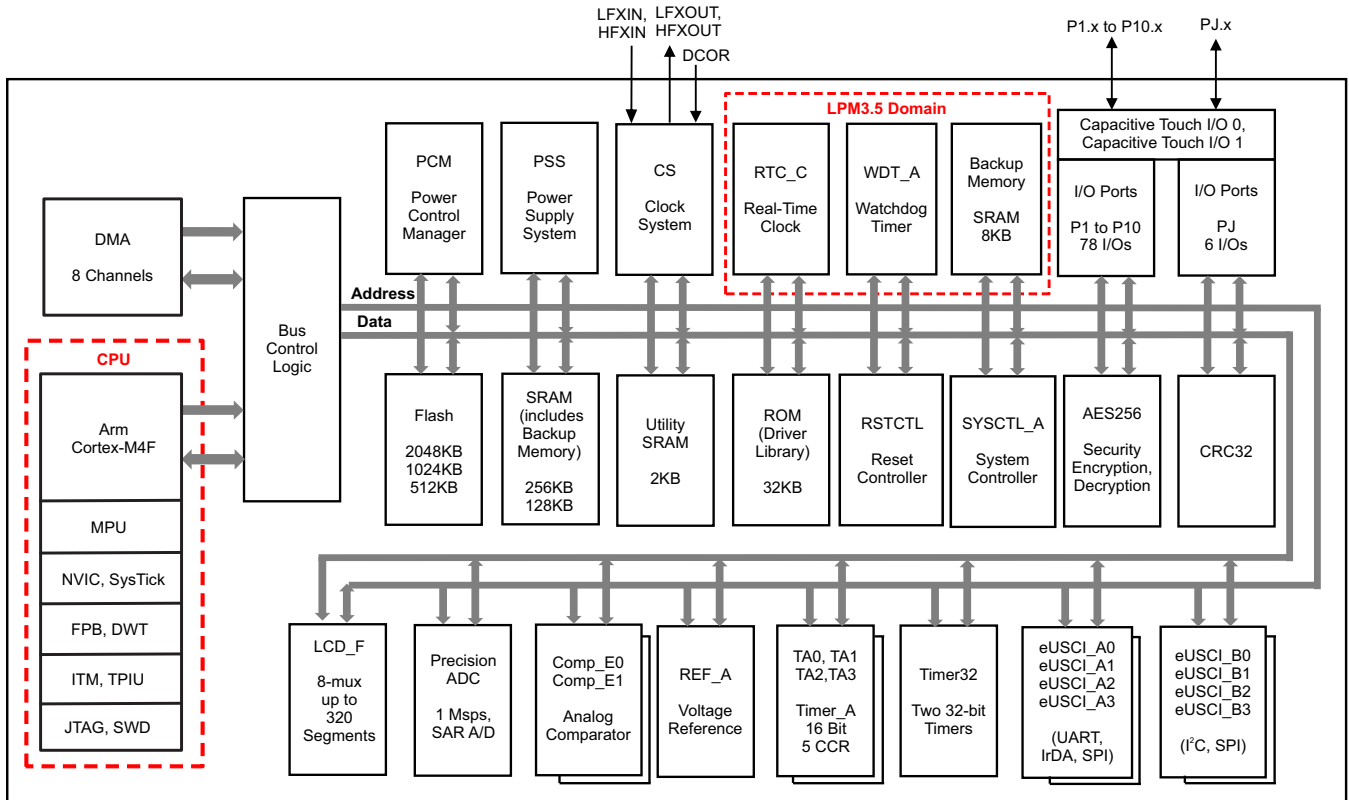

Figure 1-1. MSP432P411x Functional Block Diagram

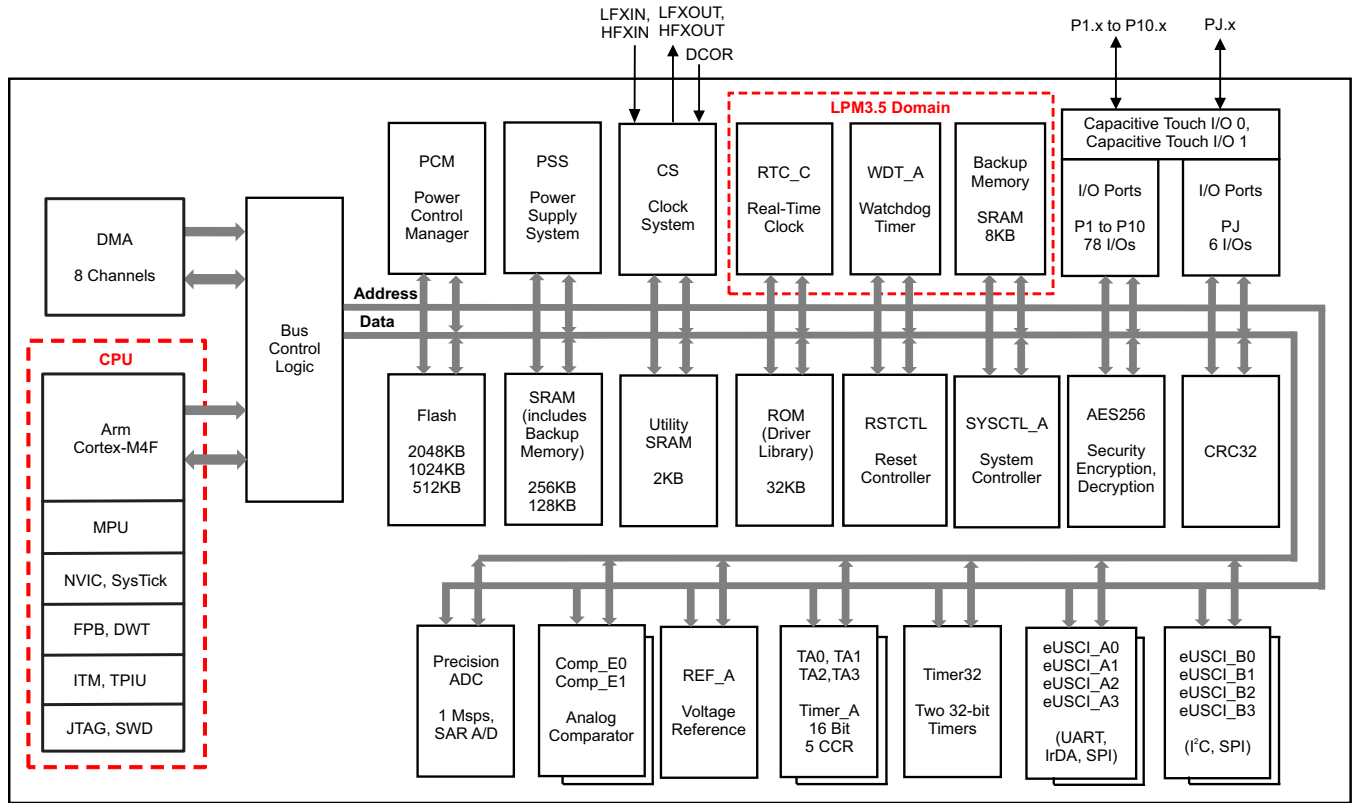

Figure 1-2. MSP432P401x Functional Block Diagram

Table of Contents

1	Device Overview	1	5.18	Current Consumption in LDO-Based LPM0 Modes.	43
1.1	Features	1	5.19	Current Consumption in DC/DC-Based LPM0 Modes	43
1.2	Applications	2	5.20	Current Consumption in Low-Frequency LPM0 Modes	43
1.3	Description	2	5.21	Current Consumption in LPM3, LPM4 Modes	44
1.4	Functional Block Diagrams	3	5.22	Current Consumption in LPM3 Modes With LCD ...	45
2	Revision History	6	5.23	Current Consumption in LPM3.5, LPM4.5 Modes ..	45
3	Device Comparison	7	5.24	Current Consumption of Digital Peripherals	46
3.1	Related Products	7	5.25	Thermal Resistance Characteristics	46
4	Terminal Configuration and Functions	8	5.26	Timing and Switching Characteristics	47
4.1	Pin Diagram for MSP432P411xl Devices	8	6	Detailed Description	98
4.2	Pin Diagram for MSP432P401xl Devices	9	6.1	Overview	98
4.3	Pin Attributes	10	6.2	Processor and Execution Features	98
4.4	Signal Descriptions	21	6.3	Memory Map	99
4.5	Pin Multiplexing	30	6.4	Memories on MSP432P4x1x	122
4.6	Buffer Types	30	6.5	DMA	127
4.7	Connections for Unused Pins	31	6.6	Memory Map Access Details	128
5	Specifications	32	6.7	Interrupts	129
5.1	Absolute Maximum Ratings	32	6.8	System Control	132
5.2	ESD Ratings	32	6.9	Peripherals	138
5.3	Recommended Operating Conditions	32	6.10	Code Development and Debug	148
5.4	Recommended External Components	33	6.11	Performance Benchmarks	150
5.5	Operating Mode V _{CC} Ranges	33	6.12	Input/Output Diagrams	152
5.6	Operating Mode CPU Frequency Ranges	34	6.13	Device Descriptors (TLV)	193
5.7	Operating Mode Peripheral Frequency Ranges	34	6.14	Identification	196
5.8	Operating Mode Execution Frequency vs Flash Wait-State Requirements	35	7	Applications, Implementation, and Layout	198
5.9	Current Consumption During Device Reset of the 100-Pin LQFP Package	36	7.1	Device Connection and Layout Fundamentals	198
5.10	Current Consumption in LDO-Based Active Modes – Dhrystone 2.1 Program	36	7.2	Peripheral and Interface-Specific Design Information	199
5.11	Current Consumption in DC/DC-Based Active Modes – Dhrystone 2.1 Program	36	8	Device and Documentation Support	201
5.12	Current Consumption in Low-Frequency Active Modes – Dhrystone 2.1 Program	37	8.1	Getting Started	201
5.13	Typical Characteristics of Active Mode Currents for CoreMark Program	38	8.2	Device Nomenclature	201
5.14	Typical Characteristics of Active Mode Currents for Prime Number Program	39	8.3	Tools and Software	202
5.15	Typical Characteristics of Active Mode Currents for Fibonacci Program	40	8.4	Documentation Support	204
5.16	Typical Characteristics of Active Mode Currents for While(1) Program	41	8.5	Related Links	206
5.17	Typical Characteristics of Low-Frequency Active Mode Currents for CoreMark Program	42	8.6	Community Resources	206
			8.7	Trademarks	206
			8.8	Electrostatic Discharge Caution	206
			8.9	Export Control Notice	206
			8.10	Glossary	207
			9	Mechanical, Packaging, and Orderable Information	207

2 Revision History

Changes from February 3, 2018 to June 17, 2019	Page
• Added that the I_{RESET} parameter applies to only the 100-pin LQFP package and not to the 64-pin VQFN package in Section 5.9, Current Consumption During Device Reset of the 100-Pin LQFP Package	36
• Changed the MIN values for the $t_{\text{HD,STA}}$, $t_{\text{SU,STA}}$, $t_{\text{HD,DAT}}$, $t_{\text{SU,DAT}}$, and $t_{\text{SU,STO}}$ parameters in Table 5-45, eUSCI Switching Characteristics (I²C Mode)	93
• Updated the text in Section 8.2, Device Nomenclature	201

3 Device Comparison

Table 3-1 summarizes the features of MSP432P4x1x devices.

Table 3-1. Device Comparison ⁽¹⁾

DEVICE	FLASH (KB)	SRAM (KB)	Precision ADC (Channels)	LCD (Segments)	COMP_E0 (Channels)	COMP_E1 (Channels)	Timer_A ⁽²⁾	eUSCI		20-mA DRIVE I/Os	TOTAL I/Os	PACKAGE
								CHANNEL A: UART, IrDA, SPI	CHANNEL B: SPI, I ² C			
MSP432P4111IPZ	2048	256	24 ext, 2 int	320	8	8	5, 5, 5, 5	4	4	4	84	100 PZ
MSP432P411YIPZ	1024	256	24 ext, 2 int	320	8	8	5, 5, 5, 5	4	4	4	84	100 PZ
MSP432P411VIPZ	512	128	24 ext, 2 int	320	8	8	5, 5, 5, 5	4	4	4	84	100 PZ
MSP432P4011IRGC	2048	256	12 ext, 2 int	N/A	2	4	5, 5, 5	3	3	4	48	64 RGC
MSP432P401YIRGC	1024	256	12 ext, 2 int	N/A	2	4	5, 5, 5	3	3	4	48	64 RGC
MSP432P401VIRGC	512	128	12 ext, 2 int	N/A	2	4	5, 5, 5	3	3	4	48	64 RGC

- (1) For the most current part, package, and ordering information for all available devices, see the *Package Option Addendum* in Section 9, or see the TI website at www.ti.com.
- (2) Each number in the sequence represents an instantiation of Timer_A with its associated number of capture/compare registers and PWM output generators available. For example, a number sequence of 3, 5 would represent two instantiations of Timer_A, the first instantiation having 3 and the second instantiation having 5 capture/compare registers and PWM output generators, respectively.

3.1 Related Products

For information about other devices in this family of products or related products, see the following links.

[TI 16-bit and 32-bit microcontrollers](#) High-performance, low-power solutions to enable the autonomous future

[Products for SimpleLink wired MCUs](#) From precision sensors to intelligent gateway to cloud

[Companion products for MSP432P4111](#) Review products that are frequently purchased or used in conjunction with this product.

[Reference designs for MSP432P4111](#) Find reference designs that leverage the best in TI technology to solve your system-level challenges.

4 Terminal Configuration and Functions

4.1 Pin Diagram for MSP432P411xl Devices

Figure 4-1 shows the pinout of the 100-pin PZ package.

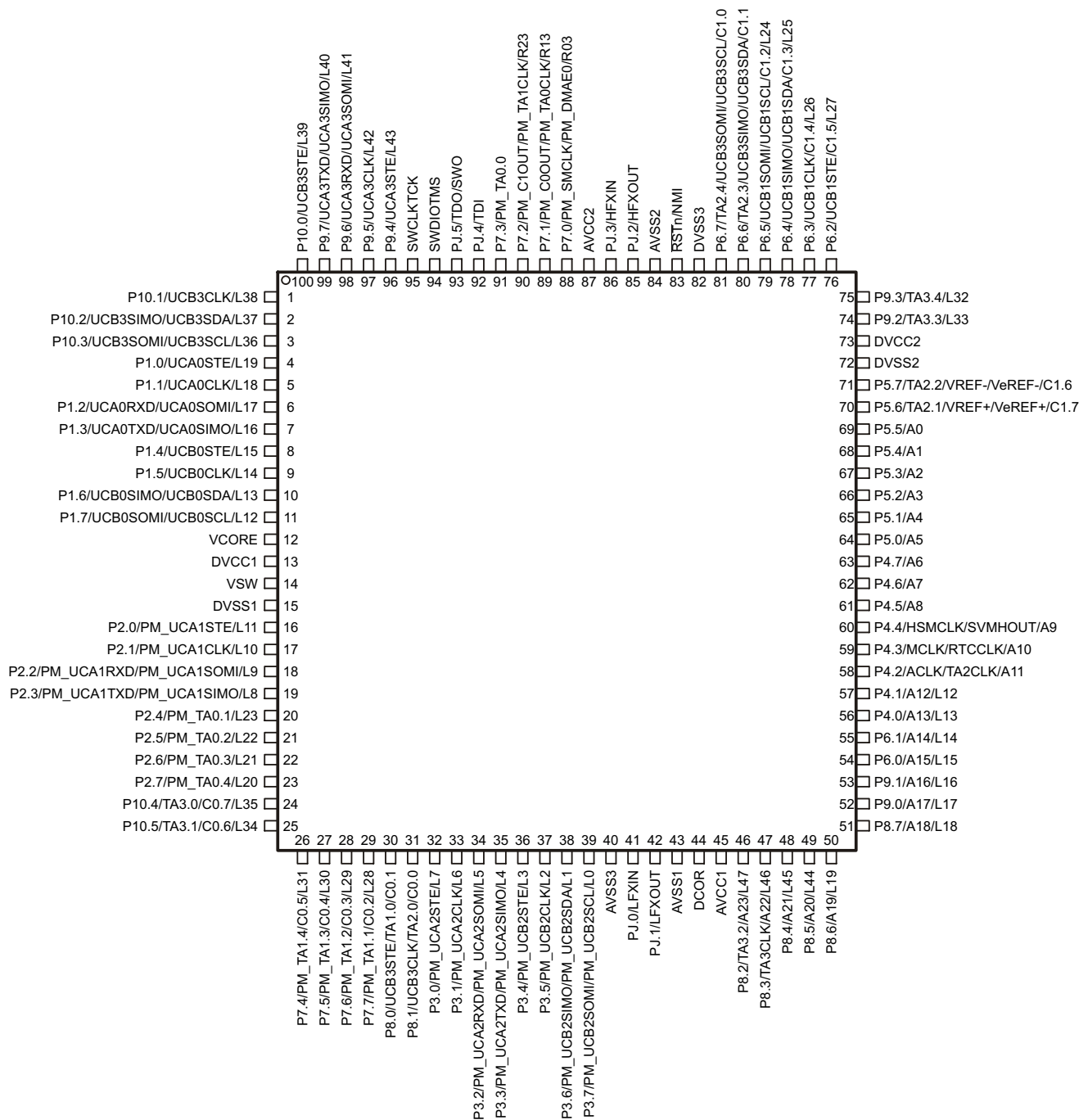

- The secondary digital functions on Ports P2, P3, and P7 are fully mappable. This pinout shows only the default mapping. See Section 6.9.2 for details.
- A glitch filter is implemented on these digital I/Os: P1.0, P1.4, P1.5, P3.0, P3.4, P3.5, P6.6, P6.7.
- UART BSL pins: P1.2 - BSLRXD, P1.3 - BSLTXD
- SPI BSL pins: P1.4 - BSLSTE, P1.5 - BSLCLK, P1.6 - BSLSIMO, P1.7 - BSLSOMI
- I²C BSL pins: P3.6 - BSLSDA, P3.7 - BSLSCL

Figure 4-1. 100-Pin PZ Package (Top View)

4.2 Pin Diagram for MSP432P401xl Devices

Figure 4-2 shows the pinout of the 64-pin RGC package.

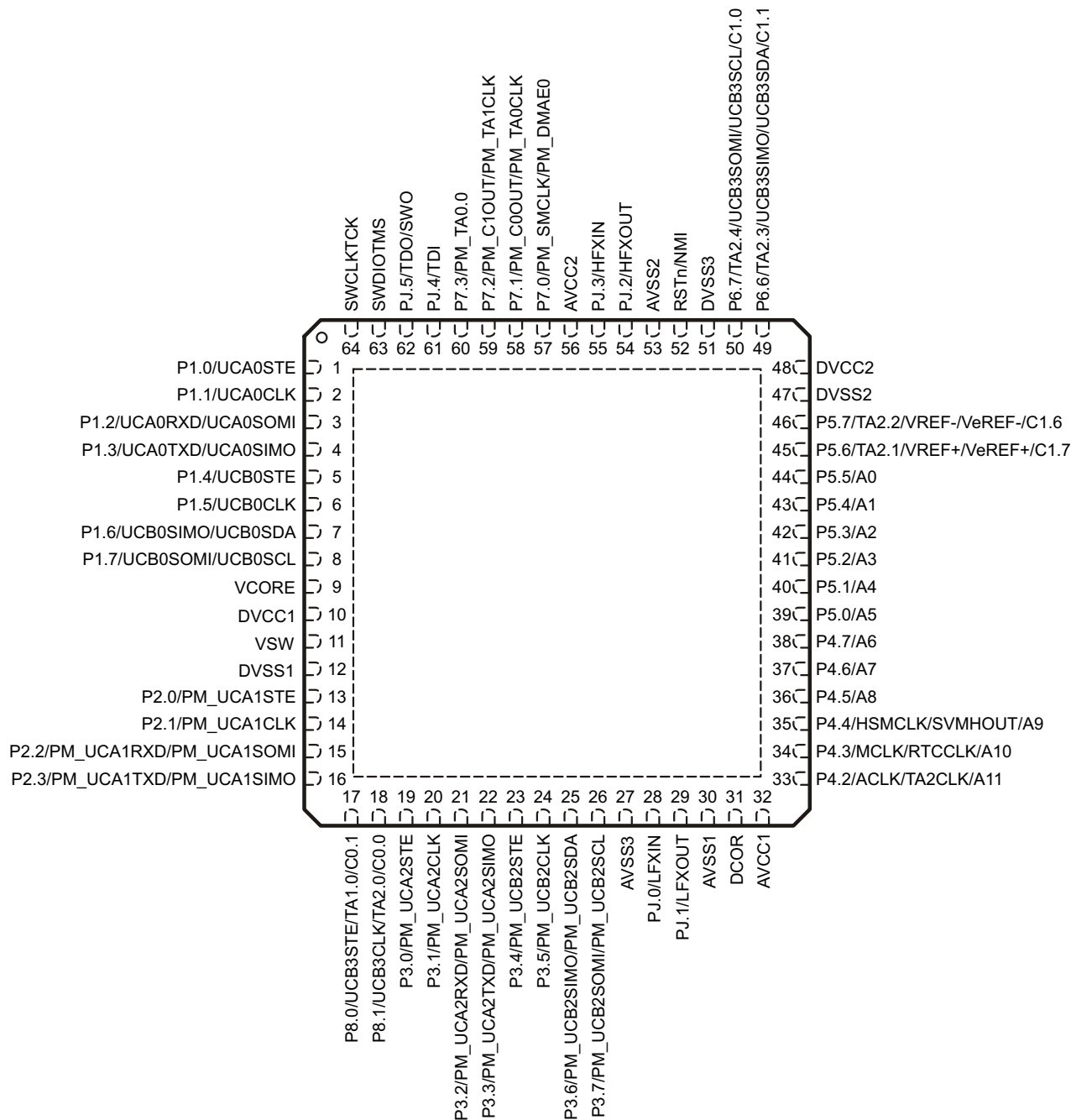

- The secondary digital functions on Ports P2, P3, and P7 are fully mappable. This pinout shows only the default mapping. See [Section 6.9.2](#) for details.
- A glitch filter is implemented on these digital I/Os: P1.0, P1.4, P1.5, P3.0, P3.4, P3.5, P6.6, P6.7.
- TI recommends connecting the thermal pad on the QFN package to DVSS.
- UART BSL pins: P1.2 - BSLRXD, P1.3 - BSLTXD
- SPI BSL pins: P1.4 - BSLSTE, P1.5 - BSLCLK, P1.6 - BSLSIMO, P1.7 - BSLSOMI
- I²C BSL pins: P3.6 - BSLSDA, P3.7 - BSLSCL

Figure 4-2. 64-Pin RGC Package (Top View)

4.3 Pin Attributes

Table 4-1 describes the attributes of the pins for the MSP432P411xl devices.

Table 4-1. Pin Attributes for MSP432P411xl

PIN NO. (PZ PACKAGE)	SIGNAL NAME ⁽¹⁾ ⁽²⁾	SIGNAL TYPE ⁽³⁾	BUFFER TYPE ⁽⁴⁾	POWER SOURCE ⁽⁵⁾	RESET STATE AFTER POR ⁽⁶⁾
1	P10.1 (RD)	I/O	LVC MOS	DVCC	OFF
	UCB3CLK	I/O	LVC MOS	DVCC	N/A
	L38	O	Analog	DVCC	N/A
2	P10.2 (RD)	I/O	LVC MOS	DVCC	OFF
	UCB3SIMO	I/O	LVC MOS	DVCC	N/A
	UCB3SDA	I/O	LVC MOS	DVCC	N/A
	L37	O	Analog	DVCC	N/A
3	P10.3 (RD)	I/O	LVC MOS	DVCC	OFF
	UCB3SOMI	I/O	LVC MOS	DVCC	N/A
	UCB3SCL	I/O	LVC MOS	DVCC	N/A
	L36	O	Analog	DVCC	N/A
4	P1.0 (RD)	I/O	LVC MOS	DVCC	OFF
	UCA0STE	I/O	LVC MOS	DVCC	N/A
	L19 ⁽⁷⁾	O	Analog	DVCC	N/A
5	P1.1 (RD)	I/O	LVC MOS	DVCC	OFF
	UCA0CLK	I/O	LVC MOS	DVCC	N/A
	L18 ⁽⁷⁾	O	Analog	DVCC	N/A
6	P1.2 (RD)	I/O	LVC MOS	DVCC	OFF
	UCA0RXD	I	LVC MOS	DVCC	N/A
	UCA0SOMI	I/O	LVC MOS	DVCC	N/A
	L17 ⁽⁷⁾	O	Analog	DVCC	N/A
7	P1.3 (RD)	I/O	LVC MOS	DVCC	OFF
	UCA0TXD	O	LVC MOS	DVCC	N/A
	UCA0SIMO	I/O	LVC MOS	DVCC	N/A
	L16 ⁽⁷⁾	O	Analog	DVCC	N/A
8	P1.4 (RD)	I/O	LVC MOS	DVCC	OFF
	UCB0STE	I/O	LVC MOS	DVCC	N/A
	L15 ⁽⁷⁾	O	Analog	DVCC	N/A
9	P1.5 (RD)	I/O	LVC MOS	DVCC	OFF
	UCB0CLK	I/O	LVC MOS	DVCC	N/A
	L14 ⁽⁷⁾	O	Analog	DVCC	N/A

(1) (RD) indicates the reset default signal name for that pin.

(2) To determine the pin mux encodings for each pin, see Section 6.12.

(3) Signal Types: I = Input, O = Output, I/O = Input or Output, P = power

(4) Buffer Types: See Section 4.6 for details

(5) The power source shown in this table is the I/O power source, which may differ from the module power source.

(6) Reset States:

OFF = High-impedance with Schmitt trigger and pullup or pulldown (if available) disabled

PD = High-impedance input with pulldown enabled

PU = High-impedance input with pullup enabled

N/A = Not applicable

(7) This LCD drive pin is also mirrored at a different location in the 100-pin PZ package. Assign the LCD drive output to only one pin at a time.

Table 4-1. Pin Attributes for MSP432P411xl (continued)

PIN NO. (PZ PACKAGE)	SIGNAL NAME ^{(1) (2)}	SIGNAL TYPE ⁽³⁾	BUFFER TYPE ⁽⁴⁾	POWER SOURCE ⁽⁵⁾	RESET STATE AFTER POR ⁽⁶⁾
10	P1.6 (RD)	I/O	LVC MOS	DVCC	OFF
	UCB0SIMO	I/O	LVC MOS	DVCC	N/A
	UCB0SDA	I/O	LVC MOS	DVCC	N/A
	L13 ⁽⁷⁾	O	Analog	DVCC	N/A
11	P1.7 (RD)	I/O	LVC MOS	DVCC	OFF
	UCB0SOMI	I/O	LVC MOS	DVCC	N/A
	UCB0SCL	I/O	LVC MOS	DVCC	N/A
	L12 ⁽⁷⁾	O	Analog	DVCC	N/A
12	VCORE	–	Power	DVCC	N/A
13	DVCC1	–	Power	N/A	N/A
14	VSW	–	Power	N/A	N/A
15	DVSS1	–	Power	N/A	N/A
16	P2.0 (RD)	I/O	LVC MOS	DVCC	OFF
	PM_UCA1STE	I/O	LVC MOS	DVCC	N/A
	L11	O	Analog	DVCC	N/A
17	P2.1 (RD)	I/O	LVC MOS	DVCC	OFF
	PM_UCA1CLK	I/O	LVC MOS	DVCC	N/A
	L10	O	Analog	DVCC	N/A
18	P2.2 (RD)	I/O	LVC MOS	DVCC	OFF
	PM_UCA1RXD	I	LVC MOS	DVCC	N/A
	PM_UCA1SOMI	I/O	LVC MOS	DVCC	N/A
	L9	O	Analog	DVCC	N/A
19	P2.3 (RD)	I/O	LVC MOS	DVCC	OFF
	PM_UCA1TXD	O	LVC MOS	DVCC	N/A
	PM_UCA1SIMO	I/O	LVC MOS	DVCC	N/A
	L8	O	Analog	DVCC	N/A
20	P2.4 (RD)	I/O	LVC MOS	DVCC	OFF
	PM_TA0.1	I/O	LVC MOS	DVCC	N/A
	L23	O	Analog	DVCC	N/A
21	P2.5 (RD)	I/O	LVC MOS	DVCC	OFF
	PM_TA0.2	I/O	LVC MOS	DVCC	N/A
	L22	O	Analog	DVCC	N/A
22	P2.6 (RD)	I/O	LVC MOS	DVCC	OFF
	PM_TA0.3	I/O	LVC MOS	DVCC	N/A
	L21	O	Analog	DVCC	N/A
23	P2.7 (RD)	I/O	LVC MOS	DVCC	OFF
	PM_TA0.4	I/O	LVC MOS	DVCC	N/A
	L20	O	Analog	DVCC	N/A
24	P10.4 (RD)	I/O	LVC MOS	DVCC	OFF
	TA3.0	I/O	LVC MOS	DVCC	N/A
	C0.7	I	Analog	DVCC	N/A
	L35	O	Analog	DVCC	N/A
25	P10.5 (RD)	I/O	LVC MOS	DVCC	OFF
	TA3.1	I/O	LVC MOS	DVCC	N/A
	C0.6	I	Analog	DVCC	N/A
	L34	O	Analog	DVCC	N/A

Table 4-1. Pin Attributes for MSP432P411xl (continued)

PIN NO. (PZ PACKAGE)	SIGNAL NAME ⁽¹⁾ ⁽²⁾	SIGNAL TYPE ⁽³⁾	BUFFER TYPE ⁽⁴⁾	POWER SOURCE ⁽⁵⁾	RESET STATE AFTER POR ⁽⁶⁾
26	P7.4 (RD)	I/O	LVC MOS	DVCC	OFF
	PM_TA1.4	I/O	LVC MOS	DVCC	N/A
	C0.5	I	Analog	DVCC	N/A
	L31	O	Analog	DVCC	N/A
27	P7.5 (RD)	I/O	LVC MOS	DVCC	OFF
	PM_TA1.3	I/O	LVC MOS	DVCC	N/A
	C0.4	I	Analog	DVCC	N/A
	L30	O	Analog	DVCC	N/A
28	P7.6 (RD)	I/O	LVC MOS	DVCC	OFF
	PM_TA1.2	I/O	LVC MOS	DVCC	N/A
	C0.3	I	Analog	DVCC	N/A
	L29	O	Analog	DVCC	N/A
29	P7.7 (RD)	I/O	LVC MOS	DVCC	OFF
	PM_TA1.1	I/O	LVC MOS	DVCC	N/A
	C0.2	I	Analog	DVCC	N/A
	L28	O	Analog	DVCC	N/A
30	P8.0 (RD)	I/O	LVC MOS	DVCC	OFF
	UCB3STE	I/O	LVC MOS	DVCC	N/A
	TA1.0	I/O	LVC MOS	DVCC	N/A
	C0.1	I	Analog	DVCC	N/A
31	P8.1 (RD)	I/O	LVC MOS	DVCC	OFF
	UCB3CLK	I/O	LVC MOS	DVCC	N/A
	TA2.0	I/O	LVC MOS	DVCC	N/A
	C0.0	I	Analog	DVCC	N/A
32	P3.0 (RD)	I/O	LVC MOS	DVCC	OFF
	PM_UCA2STE	I/O	LVC MOS	DVCC	N/A
	L7	O	Analog	DVCC	N/A
33	P3.1 (RD)	I/O	LVC MOS	DVCC	OFF
	PM_UCA2CLK	I/O	LVC MOS	DVCC	N/A
	L6	O	Analog	DVCC	N/A
34	P3.2 (RD)	I/O	LVC MOS	DVCC	OFF
	PM_UCA2RXD	I	LVC MOS	DVCC	N/A
	PM_UCA2SOMI	I/O	LVC MOS	DVCC	N/A
	L5	O	Analog	DVCC	N/A
35	P3.3 (RD)	I/O	LVC MOS	DVCC	OFF
	PM_UCA2TXD	O	LVC MOS	DVCC	N/A
	PM_UCA2SIMO	I/O	LVC MOS	DVCC	N/A
	L4	O	Analog	DVCC	N/A
36	P3.4 (RD)	I/O	LVC MOS	DVCC	OFF
	PM_UCB2STE	I/O	LVC MOS	DVCC	N/A
	L3	O	Analog	DVCC	N/A
37	P3.5 (RD)	I/O	LVC MOS	DVCC	OFF
	PM_UCB2CLK	I/O	LVC MOS	DVCC	N/A
	L2	O	Analog	DVCC	N/A

Table 4-1. Pin Attributes for MSP432P411xl (continued)

PIN NO. (PZ PACKAGE)	SIGNAL NAME ^{(1) (2)}	SIGNAL TYPE ⁽³⁾	BUFFER TYPE ⁽⁴⁾	POWER SOURCE ⁽⁵⁾	RESET STATE AFTER POR ⁽⁶⁾
38	P3.6 (RD)	I/O	LVC MOS	DVCC	OFF
	PM_UCB2SIMO	I/O	LVC MOS	DVCC	N/A
	PM_UCB2SDA	I/O	LVC MOS	DVCC	N/A
	L1	O	Analog	DVCC	N/A
39	P3.7 (RD)	I/O	LVC MOS	DVCC	OFF
	PM_UCB2SOMI	I/O	LVC MOS	DVCC	N/A
	PM_UCB2SCL	I	LVC MOS	DVCC	N/A
	L0	O	Analog	DVCC	N/A
40	AVSS3	–	Power	N/A	N/A
41	PJ.0 (RD)	I/O	LVC MOS	DVCC	OFF
	LFXIN	I	Analog	DVCC	N/A
42	PJ.1 (RD)	I/O	LVC MOS	DVCC	OFF
	LFXOUT	O	Analog	DVCC	N/A
43	AVSS1	–	Power	N/A	N/A
44	DCOR	–	Analog	N/A	N/A
45	AVCC1	–	Power	N/A	N/A
46	P8.2 (RD)	I/O	LVC MOS	DVCC	OFF
	TA3.2	I/O	LVC MOS	DVCC	N/A
	A23	I	Analog	DVCC	N/A
	L47	O	Analog	DVCC	N/A
47	P8.3 (RD)	I/O	LVC MOS	DVCC	OFF
	TA3CLK	I	LVC MOS	DVCC	N/A
	A22	I	Analog	DVCC	N/A
	L46	O	Analog	DVCC	N/A
48	P8.4 (RD)	I/O	LVC MOS	DVCC	OFF
	A21	I	Analog	DVCC	N/A
	L45	O	Analog	DVCC	N/A
49	P8.5 (RD)	I/O	LVC MOS	DVCC	OFF
	A20	I	Analog	DVCC	N/A
	L44	O	Analog	DVCC	N/A
50	P8.6 (RD)	I/O	LVC MOS	DVCC	OFF
	A19	I	Analog	DVCC	N/A
	L19 ⁽⁷⁾	O	Analog	DVCC	N/A
51	P8.7 (RD)	I/O	LVC MOS	DVCC	OFF
	A18	I	Analog	DVCC	N/A
	L18 ⁽⁷⁾	O	Analog	DVCC	N/A
52	P9.0 (RD)	I/O	LVC MOS	DVCC	OFF
	A17	I	Analog	DVCC	N/A
	L17 ⁽⁷⁾	O	Analog	DVCC	N/A
53	P9.1 (RD)	I/O	LVC MOS	DVCC	OFF
	A16	I	Analog	DVCC	N/A
	L16 ⁽⁷⁾	O	Analog	DVCC	N/A
54	P6.0 (RD)	I/O	LVC MOS	DVCC	OFF
	A15	I	Analog	DVCC	N/A
	L15 ⁽⁷⁾	O	Analog	DVCC	N/A

Table 4-1. Pin Attributes for MSP432P411xl (continued)

PIN NO. (PZ PACKAGE)	SIGNAL NAME ⁽¹⁾ ⁽²⁾	SIGNAL TYPE ⁽³⁾	BUFFER TYPE ⁽⁴⁾	POWER SOURCE ⁽⁵⁾	RESET STATE AFTER POR ⁽⁶⁾
55	P6.1 (RD)	I/O	LVC MOS	DVCC	OFF
	A14	I	Analog	DVCC	N/A
	L14 ⁽⁷⁾	O	Analog	DVCC	N/A
56	P4.0 (RD)	I/O	LVC MOS	DVCC	OFF
	A13	I	Analog	DVCC	N/A
	L13 ⁽⁷⁾	O	Analog	DVCC	N/A
57	P4.1 (RD)	I/O	LVC MOS	DVCC	OFF
	A12	I	Analog	DVCC	N/A
	L12 ⁽⁷⁾	O	Analog	DVCC	N/A
58	P4.2 (RD)	I/O	LVC MOS	DVCC	OFF
	ACLK	O	LVC MOS	DVCC	N/A
	TA2CLK	I	LVC MOS	DVCC	N/A
	A11	I	Analog	DVCC	N/A
59	P4.3 (RD)	I/O	LVC MOS	DVCC	OFF
	MCLK	O	LVC MOS	DVCC	N/A
	RTCCLK	O	LVC MOS	DVCC	N/A
	A10	I	Analog	DVCC	N/A
60	P4.4 (RD)	I/O	LVC MOS	DVCC	OFF
	HSMCLK	O	LVC MOS	DVCC	N/A
	SVMHOUT	O	LVC MOS	DVCC	N/A
	A9	I	Analog	DVCC	N/A
61	P4.5 (RD)	I/O	LVC MOS	DVCC	OFF
	A8	I	Analog	DVCC	N/A
62	P4.6 (RD)	I/O	LVC MOS	DVCC	OFF
	A7	I	Analog	DVCC	N/A
63	P4.7 (RD)	I/O	LVC MOS	DVCC	OFF
	A6	I	Analog	DVCC	N/A
64	P5.0 (RD)	I/O	LVC MOS	DVCC	OFF
	A5	I	Analog	DVCC	N/A
65	P5.1 (RD)	I/O	LVC MOS	DVCC	OFF
	A4	I	Analog	DVCC	N/A
66	P5.2 (RD)	I/O	LVC MOS	DVCC	OFF
	A3	I	Analog	DVCC	N/A
67	P5.3 (RD)	I/O	LVC MOS	DVCC	OFF
	A2	I	Analog	DVCC	N/A
68	P5.4 (RD)	I/O	LVC MOS	DVCC	OFF
	A1	I	Analog	DVCC	N/A
69	P5.5 (RD)	I/O	LVC MOS	DVCC	OFF
	A0	I	Analog	DVCC	N/A
70	P5.6 (RD)	I/O	LVC MOS	DVCC	OFF
	TA2.1	I/O	LVC MOS	DVCC	N/A
	VREF+	O	Analog	DVCC	N/A
	VeREF+	I	Analog	DVCC	N/A
	C1.7	I	Analog	DVCC	N/A

Table 4-1. Pin Attributes for MSP432P411xl (continued)

PIN NO. (PZ PACKAGE)	SIGNAL NAME ⁽¹⁾ ⁽²⁾	SIGNAL TYPE ⁽³⁾	BUFFER TYPE ⁽⁴⁾	POWER SOURCE ⁽⁵⁾	RESET STATE AFTER POR ⁽⁶⁾
71	P5.7 (RD)	I/O	LVC MOS	DVCC	OFF
	TA2.2	I/O	LVC MOS	DVCC	N/A
	VREF-	O	Analog	DVCC	N/A
	VeREF-	I	Analog	DVCC	N/A
	C1.6	I	Analog	DVCC	N/A
72	DVSS2	–	Power	N/A	N/A
73	DVCC2	–	Power	N/A	N/A
74	P9.2 (RD)	I/O	LVC MOS	DVCC	OFF
	TA3.3	I/O	LVC MOS	DVCC	N/A
	L33	O	Analog	DVCC	N/A
75	P9.3 (RD)	I/O	LVC MOS	DVCC	OFF
	TA3.4	I/O	LVC MOS	DVCC	N/A
	L32	O	Analog	DVCC	N/A
76	P6.2 (RD)	I/O	LVC MOS	DVCC	OFF
	UCB1STE	I/O	LVC MOS	DVCC	N/A
	C1.5	I	Analog	DVCC	N/A
	L27	O	Analog	DVCC	N/A
77	P6.3 (RD)	I/O	LVC MOS	DVCC	OFF
	UCB1CLK	I/O	LVC MOS	DVCC	N/A
	C1.4	I	Analog	DVCC	N/A
	L26	O	Analog	DVCC	N/A
78	P6.4 (RD)	I/O	LVC MOS	DVCC	OFF
	UCB1SIMO	I/O	LVC MOS	DVCC	N/A
	UCB1SDA	I/O	LVC MOS	DVCC	N/A
	C1.3	I	Analog	DVCC	N/A
	L25	O	Analog	DVCC	N/A
79	P6.5 (RD)	I/O	LVC MOS	DVCC	OFF
	UCB1SOMI	I/O	LVC MOS	DVCC	N/A
	UCB1SCL	I/O	LVC MOS	DVCC	N/A
	C1.2	I	Analog	DVCC	N/A
	L24	O	Analog	DVCC	N/A
80	P6.6 (RD)	I/O	LVC MOS	DVCC	OFF
	TA2.3	I/O	LVC MOS	DVCC	N/A
	UCB3SIMO	I/O	LVC MOS	DVCC	N/A
	UCB3SDA	I/O	LVC MOS	DVCC	N/A
	C1.1	I	Analog	DVCC	N/A
81	P6.7 (RD)	I/O	LVC MOS	DVCC	OFF
	TA2.4	I/O	LVC MOS	DVCC	N/A
	UCB3SOMI	I/O	LVC MOS	DVCC	N/A
	UCB3SCL	I/O	LVC MOS	DVCC	N/A
	C1.0	I	Analog	DVCC	N/A
82	DVSS3	–	Power	N/A	N/A
83	RSTn (RD)	I	LVC MOS	DVCC	PU
	NMI	I	LVC MOS	DVCC	N/A
84	AVSS2	–	Power	N/A	N/A

Table 4-1. Pin Attributes for MSP432P411xl (continued)

PIN NO. (PZ PACKAGE)	SIGNAL NAME ⁽¹⁾ ⁽²⁾	SIGNAL TYPE ⁽³⁾	BUFFER TYPE ⁽⁴⁾	POWER SOURCE ⁽⁵⁾	RESET STATE AFTER POR ⁽⁶⁾
85	PJ.2 (RD)	I/O	LVC MOS	DVCC	OFF
	HFXOUT	O	Analog	DVCC	N/A
86	PJ.3 (RD)	I/O	LVC MOS	DVCC	OFF
	HFXIN	I	Analog	DVCC	N/A
87	AVCC2	–	Power	N/A	N/A
88	P7.0 (RD)	I/O	LVC MOS	DVCC	OFF
	PM_SMCLK	O	LVC MOS	DVCC	N/A
	PM_DMAE0	I	LVC MOS	DVCC	N/A
	R03	I	Analog	DVCC	N/A
89	P7.1 (RD)	I/O	LVC MOS	DVCC	OFF
	PM_C0OUT	O	LVC MOS	DVCC	N/A
	PM_TA0CLK	I	LVC MOS	DVCC	N/A
	R13	I	Analog	DVCC	N/A
90	P7.2 (RD)	I/O	LVC MOS	DVCC	OFF
	PM_C1OUT	O	LVC MOS	DVCC	N/A
	PM_TA1CLK	I	LVC MOS	DVCC	N/A
	R23	I	Analog	DVCC	N/A
91	P7.3 (RD)	I/O	LVC MOS	DVCC	OFF
	PM_TA0.0	I/O	LVC MOS	DVCC	N/A
92	PJ.4	I/O	LVC MOS	DVCC	N/A
	TDI (RD)	I	LVC MOS	DVCC	PU
93	PJ.5	I/O	LVC MOS	DVCC	N/A
	TDO (RD)	O	LVC MOS	DVCC	N/A
	SWO	O	LVC MOS	DVCC	N/A
94	SWDIOTMS	I/O	LVC MOS	DVCC	PU
95	SWCLKTCK	I	LVC MOS	DVCC	PD
96	P9.4 (RD)	I/O	LVC MOS	DVCC	OFF
	UCA3STE	I/O	LVC MOS	DVCC	N/A
	L43	O	Analog	DVCC	N/A
97	P9.5 (RD)	I/O	LVC MOS	DVCC	OFF
	UCA3CLK	I/O	LVC MOS	DVCC	N/A
	L42	O	Analog	DVCC	N/A
98	P9.6 (RD)	I/O	LVC MOS	DVCC	OFF
	UCA3RXD	I	LVC MOS	DVCC	N/A
	UCA3SOMI	I/O	LVC MOS	DVCC	N/A
	L41	O	Analog	DVCC	N/A
99	P9.7 (RD)	I/O	LVC MOS	DVCC	OFF
	UCA3TXD	O	LVC MOS	DVCC	N/A
	UCA3SIMO	I/O	LVC MOS	DVCC	N/A
	L40	O	Analog	DVCC	N/A
100	P10.0 (RD)	I/O	LVC MOS	DVCC	OFF
	UCB3STE	I/O	LVC MOS	DVCC	N/A
	L39	O	Analog	DVCC	N/A

Table 4-2 describes the attributes of the pins for the MSP432P401xl devices.

Table 4-2. Pin Attributes for MSP432P401xl

PIN NO. (RGC PACKAGE)	SIGNAL NAME ^{(1) (2)}	SIGNAL TYPE ⁽³⁾	BUFFER TYPE ⁽⁴⁾	POWER SOURCE ⁽⁵⁾	RESET STATE AFTER POR ⁽⁶⁾
1	P1.0 (RD)	I/O	LVC MOS	DVCC	OFF
	UCA0STE	I/O	LVC MOS	DVCC	N/A
2	P1.1 (RD)	I/O	LVC MOS	DVCC	OFF
	UCA0CLK	I/O	LVC MOS	DVCC	N/A
3	P1.2 (RD)	I/O	LVC MOS	DVCC	OFF
	UCA0RXD	I	LVC MOS	DVCC	N/A
	UCA0SOMI	I/O	LVC MOS	DVCC	N/A
4	P1.3 (RD)	I/O	LVC MOS	DVCC	OFF
	UCA0TXD	O	LVC MOS	DVCC	N/A
	UCA0SIMO	I/O	LVC MOS	DVCC	N/A
5	P1.4 (RD)	I/O	LVC MOS	DVCC	OFF
	UCB0STE	I/O	LVC MOS	DVCC	N/A
6	P1.5 (RD)	I/O	LVC MOS	DVCC	OFF
	UCB0CLK	I/O	LVC MOS	DVCC	N/A
7	P1.6 (RD)	I/O	LVC MOS	DVCC	OFF
	UCB0SIMO	I/O	LVC MOS	DVCC	N/A
	UCB0SDA	I/O	LVC MOS	DVCC	N/A
8	P1.7 (RD)	I/O	LVC MOS	DVCC	OFF
	UCB0SOMI	I/O	LVC MOS	DVCC	N/A
	UCB0SCL	I/O	LVC MOS	DVCC	N/A
9	VCORE	–	Power	DVCC	N/A
10	DVCC1	–	Power	N/A	N/A
11	VSW	–	Power	N/A	N/A
12	DVSS1	–	Power	N/A	N/A
13	P2.0 (RD)	I/O	LVC MOS	DVCC	OFF
	PM_UCA1STE	I/O	LVC MOS	DVCC	N/A
14	P2.1 (RD)	I/O	LVC MOS	DVCC	OFF
	PM_UCA1CLK	I/O	LVC MOS	DVCC	N/A
15	P2.2 (RD)	I/O	LVC MOS	DVCC	OFF
	PM_UCA1RXD	I	LVC MOS	DVCC	N/A
	PM_UCA1SOMI	I/O	LVC MOS	DVCC	N/A
16	P2.3 (RD)	I/O	LVC MOS	DVCC	OFF
	PM_UCA1TXD	O	LVC MOS	DVCC	N/A
	PM_UCA1SIMO	I/O	LVC MOS	DVCC	N/A

(1) (RD) indicates the reset default signal name for that pin.

(2) To determine the pin mux encodings for each pin, see [Section 6.12](#).

(3) Signal Types: I = Input, O = Output, I/O = Input or Output, P = power

(4) Buffer Types: See [Section 4.6](#) for details

(5) The power source shown in this table is the I/O power source, which may differ from the module power source.

(6) Reset States:

OFF = High-impedance with Schmitt trigger and pullup or pulldown (if available) disabled

PD = High-impedance input with pulldown enabled

PU = High-impedance input with pullup enabled

N/A = Not applicable

Table 4-2. Pin Attributes for MSP432P401xl (continued)

PIN NO. (RGC PACKAGE)	SIGNAL NAME ⁽¹⁾ ⁽²⁾	SIGNAL TYPE ⁽³⁾	BUFFER TYPE ⁽⁴⁾	POWER SOURCE ⁽⁵⁾	RESET STATE AFTER POR ⁽⁶⁾
17	P8.0 (RD)	I/O	LVC MOS	DVCC	OFF
	UCB3STE	I/O	LVC MOS	DVCC	N/A
	TA1.0	I/O	LVC MOS	DVCC	N/A
	C0.1	I	Analog	DVCC	N/A
18	P8.1 (RD)	I/O	LVC MOS	DVCC	OFF
	UCB3CLK	I/O	LVC MOS	DVCC	N/A
	TA2.0	I/O	LVC MOS	DVCC	N/A
	C0.0	I	Analog	DVCC	N/A
19	P3.0 (RD)	I/O	LVC MOS	DVCC	OFF
	PM_UCA2STE	I/O	LVC MOS	DVCC	N/A
20	P3.1 (RD)	I/O	LVC MOS	DVCC	OFF
	PM_UCA2CLK	I/O	LVC MOS	DVCC	N/A
21	P3.2 (RD)	I/O	LVC MOS	DVCC	OFF
	PM_UCA2RXD	I	LVC MOS	DVCC	N/A
	PM_UCA2SOMI	I/O	LVC MOS	DVCC	N/A
22	P3.3 (RD)	I/O	LVC MOS	DVCC	OFF
	PM_UCA2TXD	O	LVC MOS	DVCC	N/A
	PM_UCA2SIMO	I/O	LVC MOS	DVCC	N/A
23	P3.4 (RD)	I/O	LVC MOS	DVCC	OFF
	PM_UCB2STE	I/O	LVC MOS	DVCC	N/A
24	P3.5 (RD)	I/O	LVC MOS	DVCC	OFF
	PM_UCB2CLK	I/O	LVC MOS	DVCC	N/A
25	P3.6 (RD)	I/O	LVC MOS	DVCC	OFF
	PM_UCB2SIMO	I/O	LVC MOS	DVCC	N/A
	PM_UCB2SDA	I/O	LVC MOS	DVCC	N/A
26	P3.7 (RD)	I/O	LVC MOS	DVCC	OFF
	PM_UCB2SOMI	I/O	LVC MOS	DVCC	N/A
	PM_UCB2SCL	I	LVC MOS	DVCC	N/A
27	AVSS3	–	Power	N/A	N/A
28	PJ.0 (RD)	I/O	LVC MOS	DVCC	OFF
	LFXIN	I	Analog	DVCC	N/A
29	PJ.1 (RD)	I/O	LVC MOS	DVCC	OFF
	LFXOUT	O	Analog	DVCC	N/A
30	AVSS1	–	Power	N/A	N/A
31	DCOR	–	Analog	N/A	N/A
32	AVCC1	–	Power	N/A	N/A
33	P4.2 (RD)	I/O	LVC MOS	DVCC	OFF
	ACLK	O	LVC MOS	DVCC	N/A
	TA2CLK	I	LVC MOS	DVCC	N/A
	A11	I	Analog	DVCC	N/A
34	P4.3 (RD)	I/O	LVC MOS	DVCC	OFF
	MCLK	O	LVC MOS	DVCC	N/A
	RTCCLK	O	LVC MOS	DVCC	N/A
	A10	I	Analog	DVCC	N/A

Table 4-2. Pin Attributes for MSP432P401xl (continued)

PIN NO. (RGC PACKAGE)	SIGNAL NAME ⁽¹⁾ ⁽²⁾	SIGNAL TYPE ⁽³⁾	BUFFER TYPE ⁽⁴⁾	POWER SOURCE ⁽⁵⁾	RESET STATE AFTER POR ⁽⁶⁾
35	P4.4 (RD)	I/O	LVC MOS	DVCC	OFF
	HSMCLK	O	LVC MOS	DVCC	N/A
	SVMHOUT	O	LVC MOS	DVCC	N/A
	A9	I	Analog	DVCC	N/A
36	P4.5 (RD)	I/O	LVC MOS	DVCC	OFF
	A8	I	Analog	DVCC	N/A
37	P4.6 (RD)	I/O	LVC MOS	DVCC	OFF
	A7	I	Analog	DVCC	N/A
38	P4.7 (RD)	I/O	LVC MOS	DVCC	OFF
	A6	I	Analog	DVCC	N/A
39	P5.0 (RD)	I/O	LVC MOS	DVCC	OFF
	A5	I	Analog	DVCC	N/A
40	P5.1 (RD)	I/O	LVC MOS	DVCC	OFF
	A4	I	Analog	DVCC	N/A
41	P5.2 (RD)	I/O	LVC MOS	DVCC	OFF
	A3	I	Analog	DVCC	N/A
42	P5.3 (RD)	I/O	LVC MOS	DVCC	OFF
	A2	I	Analog	DVCC	N/A
43	P5.4 (RD)	I/O	LVC MOS	DVCC	OFF
	A1	I	Analog	DVCC	N/A
44	P5.5 (RD)	I/O	LVC MOS	DVCC	OFF
	A0	I	Analog	DVCC	N/A
45	P5.6 (RD)	I/O	LVC MOS	DVCC	OFF
	TA2.1	I/O	LVC MOS	DVCC	N/A
	VREF+	O	Analog	DVCC	N/A
	VeREF+	I	Analog	DVCC	N/A
	C1.7	I	Analog	DVCC	N/A
46	P5.7 (RD)	I/O	LVC MOS	DVCC	OFF
	TA2.2	I/O	LVC MOS	DVCC	N/A
	VREF-	O	Analog	DVCC	N/A
	VeREF-	I	Analog	DVCC	N/A
	C1.6	I	Analog	DVCC	N/A
47	DVSS2	–	Power	N/A	N/A
48	DVCC2	–	Power	N/A	N/A
49	P6.6 (RD)	I/O	LVC MOS	DVCC	OFF
	TA2.3	I/O	LVC MOS	DVCC	N/A
	UCB3SIMO	I/O	LVC MOS	DVCC	N/A
	UCB3SDA	I/O	LVC MOS	DVCC	N/A
	C1.1	I	Analog	DVCC	N/A
50	P6.7 (RD)	I/O	LVC MOS	DVCC	OFF
	TA2.4	I/O	LVC MOS	DVCC	N/A
	UCB3SOMI	I/O	LVC MOS	DVCC	N/A
	UCB3SCL	I/O	LVC MOS	DVCC	N/A
	C1.0	I	Analog	DVCC	N/A
51	DVSS3	–	Power	N/A	N/A

Table 4-2. Pin Attributes for MSP432P401xl (continued)

PIN NO. (RGC PACKAGE)	SIGNAL NAME ⁽¹⁾ ⁽²⁾	SIGNAL TYPE ⁽³⁾	BUFFER TYPE ⁽⁴⁾	POWER SOURCE ⁽⁵⁾	RESET STATE AFTER POR ⁽⁶⁾
52	RSTn (RD)	I	LVC MOS	DVCC	PU
	NMI	I	LVC MOS	DVCC	N/A
53	AVSS2	–	Power	N/A	N/A
54	PJ.2 (RD)	I/O	LVC MOS	DVCC	OFF
	HFXOUT	O	Analog	DVCC	N/A
55	PJ.3 (RD)	I/O	LVC MOS	DVCC	OFF
	HFXIN	I	Analog	DVCC	N/A
56	AVCC2	–	Power	N/A	N/A
57	P7.0 (RD)	I/O	LVC MOS	DVCC	OFF
	PM_SMCLK	O	LVC MOS	DVCC	N/A
	PM_DMAE0	I	LVC MOS	DVCC	N/A
58	P7.1 (RD)	I/O	LVC MOS	DVCC	OFF
	PM_COOUT	O	LVC MOS	DVCC	N/A
	PM_TA0CLK	I	LVC MOS	DVCC	N/A
59	P7.2 (RD)	I/O	LVC MOS	DVCC	OFF
	PM_C1OUT	O	LVC MOS	DVCC	N/A
	PM_TA1CLK	I	LVC MOS	DVCC	N/A
60	P7.3 (RD)	I/O	LVC MOS	DVCC	OFF
	PM_TA0.0	I/O	LVC MOS	DVCC	N/A
61	PJ.4	I/O	LVC MOS	DVCC	N/A
	TDI (RD)	I	LVC MOS	DVCC	PU
62	PJ.5	I/O	LVC MOS	DVCC	N/A
	TDO (RD)	O	LVC MOS	DVCC	N/A
	SWO	O	LVC MOS	DVCC	N/A
63	SWDIOTMS	I/O	LVC MOS	DVCC	PU
64	SWCLKTCK	I	LVC MOS	DVCC	PD
Pad	QFN Pad	–	–	N/A	–

4.4 Signal Descriptions

Table 4-3 describes the signals for all device variants and package options.

Table 4-3. Signal Descriptions

FUNCTION	SIGNAL NAME	SIGNAL NO. ⁽¹⁾		SIGNAL TYPE ⁽²⁾	DESCRIPTION
		PZ	RGC		
ADC	A0	69	44	I	ADC analog input A0
	A1	68	43	I	ADC analog input A1
	A2	67	42	I	ADC analog input A2
	A3	66	41	I	ADC analog input A3
	A4	65	40	I	ADC analog input A4
	A5	64	39	I	ADC analog input A5
	A6	63	38	I	ADC analog input A6
	A7	62	37	I	ADC analog input A7
	A8	61	36	I	ADC analog input A8
	A9	60	35	I	ADC analog input A9
	A10	59	34	I	ADC analog input A10
	A11	58	33	I	ADC analog input A11
	A12	57	N/A	I	ADC analog input A12
	A13	56	N/A	I	ADC analog input A13
	A14	55	N/A	I	ADC analog input A14
	A15	54	N/A	I	ADC analog input A15
	A16	53	N/A	I	ADC analog input A16
	A17	52	N/A	I	ADC analog input A17
	A18	51	N/A	I	ADC analog input A18
	A19	50	N/A	I	ADC analog input A19
	A20	49	N/A	I	ADC analog input A20
	A21	48	N/A	I	ADC analog input A21
	A22	47	N/A	I	ADC analog input A22
A23	46	N/A	I	ADC analog input A23	
Clock	ACLK	58	33	O	ACLK clock output
	DCOR	44	31	–	DCO external resistor pin
	HFXIN	86	55	I	Input for high-frequency crystal oscillator HFXT
	HFXOUT	85	54	O	Output for high-frequency crystal oscillator HFXT
	HSMCLK	60	35	O	HSMCLK clock output
	LFXIN	41	28	I	Input for low-frequency crystal oscillator LFXT
	LFXOUT	42	29	O	Output of low-frequency crystal oscillator LFXT
MCLK	59	34	O	MCLK clock output	

(1) N/A = not available

(2) I = input, O = output

Table 4-3. Signal Descriptions (continued)

FUNCTION	SIGNAL NAME	SIGNAL NO. ⁽¹⁾		SIGNAL TYPE ⁽²⁾	DESCRIPTION
		PZ	RGC		
Comparator	C0.0	31	18	I	Comparator_E0 input 0
	C0.1	30	17	I	Comparator_E0 input 1
	C0.2	29	N/A	I	Comparator_E0 input 2
	C0.3	28	N/A	I	Comparator_E0 input 3
	C0.4	27	N/A	I	Comparator_E0 input 4
	C0.5	26	N/A	I	Comparator_E0 input 5
	C0.6	25	N/A	I	Comparator_E0 input 6
	C0.7	24	N/A	I	Comparator_E0 input 7
	C1.0	81	50	I	Comparator_E1 input 0
	C1.1	80	49	I	Comparator_E1 input 1
	C1.2	79	N/A	I	Comparator_E1 input 2
	C1.3	78	N/A	I	Comparator_E1 input 3
	C1.4	77	N/A	I	Comparator_E1 input 4
	C1.5	76	N/A	I	Comparator_E1 input 5
	C1.6	71	46	I	Comparator_E1 input 6
	C1.7	70	45	I	Comparator_E1 input 7
LCD ⁽³⁾	L0	39	N/A	O	LCD drive pin 0 for either segment or common output
	L1	38	N/A	O	LCD drive pin 1 for either segment or common output
	L2	37	N/A	O	LCD drive pin 2 for either segment or common output
	L3	36	N/A	O	LCD drive pin 3 for either segment or common output
	L4	35	N/A	O	LCD drive pin 4 for either segment or common output
	L5	34	N/A	O	LCD drive pin 5 for either segment or common output
	L6	33	N/A	O	LCD drive pin 6 for either segment or common output
	L7	32	N/A	O	LCD drive pin 7 for either segment or common output
	L8	19	N/A	O	LCD drive pin 8 for either segment or common output
	L9	18	N/A	O	LCD drive pin 9 for either segment or common output
	L10	17	N/A	O	LCD drive pin 10 for either segment or common output
	L11	16	N/A	O	LCD drive pin 11 for either segment or common output
	L12 ⁽⁴⁾	11 57	N/A	O	LCD drive pin 12 for either segment or common output
	L13 ⁽⁴⁾	10 56	N/A	O	LCD drive pin 13 for either segment or common output
	L14 ⁽⁴⁾	9 55	N/A	O	LCD drive pin 14 for either segment or common output
	L15 ⁽⁴⁾	8 54	N/A	O	LCD drive pin 15 for either segment or common output
	L16 ⁽⁴⁾	7 53	N/A	O	LCD drive pin 16 for either segment or common output
	L17 ⁽⁴⁾	6 52	N/A	O	LCD drive pin 17 for either segment or common output
	L18 ⁽⁴⁾	5 51	N/A	O	LCD drive pin 18 for either segment or common output
L19 ⁽⁴⁾	4 50	N/A	O	LCD drive pin 19 for either segment or common output	

(3) Available only on MSP432P411x devices.

(4) This LCD drive pin is also mirrored at a different location in the 100-pin PZ package. Assign the LCD drive output to only one pin at a time.

Table 4-3. Signal Descriptions (continued)

FUNCTION	SIGNAL NAME	SIGNAL NO. ⁽¹⁾		SIGNAL TYPE ⁽²⁾	DESCRIPTION
		PZ	RGC		
LCD ⁽³⁾ (continued)	L20	23	N/A	O	LCD drive pin 20 for either segment or common output
	L21	22	N/A	O	LCD drive pin 21 for either segment or common output
	L22	21	N/A	O	LCD drive pin 22 for either segment or common output
	L23	20	N/A	O	LCD drive pin 23 for either segment or common output
	L24	79	N/A	O	LCD drive pin 24 for either segment or common output
	L25	78	N/A	O	LCD drive pin 25 for either segment or common output
	L26	77	N/A	O	LCD drive pin 26 for either segment or common output
	L27	76	N/A	O	LCD drive pin 27 for either segment or common output
	L28	29	N/A	O	LCD drive pin 28 for either segment or common output
	L29	28	N/A	O	LCD drive pin 29 for either segment or common output
	L30	27	N/A	O	LCD drive pin 30 for either segment or common output
	L31	26	N/A	O	LCD drive pin 31 for either segment or common output
	L32	75	N/A	O	LCD drive pin 32 for either segment or common output
	L33	74	N/A	O	LCD drive pin 33 for either segment or common output
	L34	25	N/A	O	LCD drive pin 34 for either segment or common output
	L35	24	N/A	O	LCD drive pin 35 for either segment or common output
	L36	3	N/A	O	LCD drive pin 36 for either segment or common output
	L37	2	N/A	O	LCD drive pin 37 for either segment or common output
	L38	1	N/A	O	LCD drive pin 38 for either segment or common output
	L39	100	N/A	O	LCD drive pin 39 for either segment or common output
	L40	99	N/A	O	LCD drive pin 40 for either segment or common output
	L41	98	N/A	O	LCD drive pin 41 for either segment or common output
	L42	97	N/A	O	LCD drive pin 42 for either segment or common output
	L43	96	N/A	O	LCD drive pin 43 for either segment or common output
	L44	49	N/A	O	LCD drive pin 44 for either segment or common output
	L45	48	N/A	O	LCD drive pin 45 for either segment or common output
	L46	47	N/A	O	LCD drive pin 46 for either segment or common output
	L47	46	N/A	O	LCD drive pin 47 for either segment or common output
	R03	88	N/A	I	Input port of fourth most positive analog LCD voltage V4 in external bias mode
	R13	89	N/A	I	Input port of fourth most positive analog LCD voltage V3 in external bias mode
R23	90	N/A	I	Input port of fourth most positive analog LCD voltage V2 in external bias mode	
Debug	SWCLKTCK	95	64	I	Serial wire clock input (SWCLK)/JTAG clock input (TCK)
	SWDIOTMS	94	63	I/O	Serial wire data input/output (SWDIO)/JTAG test mode select (TMS)
	SWO	93	62	O	Serial wire trace output
	TDI	92	61	I	JTAG test data input
	TDO	93	62	O	JTAG test data output

Table 4-3. Signal Descriptions (continued)

FUNCTION	SIGNAL NAME	SIGNAL NO. ⁽¹⁾		SIGNAL TYPE ⁽²⁾	DESCRIPTION
		PZ	RGC		
GPIO Port 1	P1.0	4	1	I/O	General-purpose digital I/O with port interrupt, wake-up, and glitch filtering capability
	P1.1	5	2	I/O	General-purpose digital I/O with port interrupt and wake-up capability
	P1.2	6	3	I/O	General-purpose digital I/O with port interrupt and wake-up capability
	P1.3	7	4	I/O	General-purpose digital I/O with port interrupt and wake-up capability
	P1.4	8	5	I/O	General-purpose digital I/O with port interrupt, wake-up, and glitch filtering capability
	P1.5	9	6	I/O	General-purpose digital I/O with port interrupt, wake-up, and glitch filtering capability
	P1.6	10	7	I/O	General-purpose digital I/O with port interrupt and wake-up capability
	P1.7	11	8	I/O	General-purpose digital I/O with port interrupt and wake-up capability
GPIO Port 2	P2.0	16	13	I/O	General-purpose digital I/O with port interrupt and wake-up capability and with reconfigurable port mapping secondary function. This I/O can be configured for high drive operation with a drive capability of up to 20 mA.
	P2.1	17	14	I/O	General-purpose digital I/O with port interrupt and wake-up capability and with reconfigurable port mapping secondary function. This I/O can be configured for high drive operation with a drive capability of up to 20 mA.
	P2.2	18	15	I/O	General-purpose digital I/O with port interrupt and wake-up capability and with reconfigurable port mapping secondary function. This I/O can be configured for high drive operation with a drive capability of up to 20 mA.
	P2.3	19	16	I/O	General-purpose digital I/O with port interrupt and wake-up capability and with reconfigurable port mapping secondary function. This I/O can be configured for high drive operation with a drive capability of up to 20 mA.
	P2.4	20	N/A	I/O	General-purpose digital I/O with port interrupt and wake-up capability and with reconfigurable port mapping secondary function
	P2.5	21	N/A	I/O	General-purpose digital I/O with port interrupt and wake-up capability and with reconfigurable port mapping secondary function
	P2.6	22	N/A	I/O	General-purpose digital I/O with port interrupt and wake-up capability and with reconfigurable port mapping secondary function
	P2.7	23	N/A	I/O	General-purpose digital I/O with port interrupt and wake-up capability and with reconfigurable port mapping secondary function

Table 4-3. Signal Descriptions (continued)

FUNCTION	SIGNAL NAME	SIGNAL NO. ⁽¹⁾		SIGNAL TYPE ⁽²⁾	DESCRIPTION
		PZ	RGC		
GPIO Port 3	P3.0	32	19	I/O	General-purpose digital I/O with port interrupt, wake-up, and glitch filtering capability, and with reconfigurable port mapping secondary function
	P3.1	33	20	I/O	General-purpose digital I/O with port interrupt and wake-up capability and with reconfigurable port mapping secondary function
	P3.2	34	21	I/O	General-purpose digital I/O with port interrupt and wake-up capability and with reconfigurable port mapping secondary function
	P3.3	35	22	I/O	General-purpose digital I/O with port interrupt and wake-up capability and with reconfigurable port mapping secondary function
	P3.4	36	23	I/O	General-purpose digital I/O with port interrupt, wake-up, and glitch filtering capability, and with reconfigurable port mapping secondary function
	P3.5	37	24	I/O	General-purpose digital I/O with port interrupt, wake-up, and glitch filtering capability, and with reconfigurable port mapping secondary function
	P3.6	38	25	I/O	General-purpose digital I/O with port interrupt and wake-up capability and with reconfigurable port mapping secondary function
	P3.7	39	26	I/O	General-purpose digital I/O with port interrupt and wake-up capability and with reconfigurable port mapping secondary function
GPIO Port 4	P4.0	56	N/A	I/O	General-purpose digital I/O with port interrupt and wake-up capability
	P4.1	57	N/A	I/O	General-purpose digital I/O with port interrupt and wake-up capability
	P4.2	58	33	I/O	General-purpose digital I/O with port interrupt and wake-up capability
	P4.3	59	34	I/O	General-purpose digital I/O with port interrupt and wake-up capability
	P4.4	60	35	I/O	General-purpose digital I/O with port interrupt and wake-up capability
	P4.5	61	36	I/O	General-purpose digital I/O with port interrupt and wake-up capability
	P4.6	62	37	I/O	General-purpose digital I/O with port interrupt and wake-up capability
	P4.7	63	38	I/O	General-purpose digital I/O with port interrupt and wake-up capability
GPIO Port 5	P5.0	64	39	I/O	General-purpose digital I/O with port interrupt and wake-up capability
	P5.1	65	40	I/O	General-purpose digital I/O with port interrupt and wake-up capability
	P5.2	66	41	I/O	General-purpose digital I/O with port interrupt and wake-up capability
	P5.3	67	42	I/O	General-purpose digital I/O with port interrupt and wake-up capability
	P5.4	68	43	I/O	General-purpose digital I/O with port interrupt and wake-up capability
	P5.5	69	44	I/O	General-purpose digital I/O with port interrupt and wake-up capability
	P5.6	70	45	I/O	General-purpose digital I/O with port interrupt and wake-up capability
	P5.7	71	46	I/O	General-purpose digital I/O with port interrupt and wake-up capability

Table 4-3. Signal Descriptions (continued)

FUNCTION	SIGNAL NAME	SIGNAL NO. ⁽¹⁾		SIGNAL TYPE ⁽²⁾	DESCRIPTION
		PZ	RGC		
GPIO Port 6	P6.0	54	N/A	I/O	General-purpose digital I/O with port interrupt and wake-up capability
	P6.1	55	N/A	I/O	General-purpose digital I/O with port interrupt and wake-up capability
	P6.2	76	N/A	I/O	General-purpose digital I/O with port interrupt and wake-up capability
	P6.3	77	N/A	I/O	General-purpose digital I/O with port interrupt and wake-up capability
	P6.4	78	N/A	I/O	General-purpose digital I/O with port interrupt and wake-up capability
	P6.5	79	N/A	I/O	General-purpose digital I/O with port interrupt and wake-up capability
	P6.6	80	49	I/O	General-purpose digital I/O with port interrupt, wake-up, and glitch filtering capability
	P6.7	81	50	I/O	General-purpose digital I/O with port interrupt, wake-up, and glitch filtering capability
GPIO Port 7	P7.0	88	57	I/O	General-purpose digital I/O with reconfigurable port mapping secondary function (RD)
	P7.1	89	58	I/O	General-purpose digital I/O with reconfigurable port mapping secondary function (RD)
	P7.2	90	59	I/O	General-purpose digital I/O with reconfigurable port mapping secondary function (RD)
	P7.3	91	60	I/O	General-purpose digital I/O with reconfigurable port mapping secondary function (RD)
	P7.4	26	N/A	I/O	General-purpose digital I/O with reconfigurable port mapping secondary function (RD)
	P7.5	27	N/A	I/O	General-purpose digital I/O with reconfigurable port mapping secondary function (RD)
	P7.6	28	N/A	I/O	General-purpose digital I/O with reconfigurable port mapping secondary function (RD)
	P7.7	29	N/A	I/O	General-purpose digital I/O with reconfigurable port mapping secondary function (RD)
GPIO Port 8	P8.0	30	17	I/O	General-purpose digital I/O
	P8.1	31	18	I/O	General-purpose digital I/O
	P8.2	46	N/A	I/O	General-purpose digital I/O
	P8.3	47	N/A	I/O	General-purpose digital I/O
	P8.4	48	N/A	I/O	General-purpose digital I/O
	P8.5	49	N/A	I/O	General-purpose digital I/O
	P8.6	50	N/A	I/O	General-purpose digital I/O
	P8.7	51	N/A	I/O	General-purpose digital I/O
GPIO Port 9	P9.0	52	N/A	I/O	General-purpose digital I/O
	P9.1	53	N/A	I/O	General-purpose digital I/O
	P9.2	74	N/A	I/O	General-purpose digital I/O
	P9.3	75	N/A	I/O	General-purpose digital I/O
	P9.4	96	N/A	I/O	General-purpose digital I/O
	P9.5	97	N/A	I/O	General-purpose digital I/O
	P9.6	98	N/A	I/O	General-purpose digital I/O
	P9.7	99	N/A	I/O	General-purpose digital I/O

Table 4-3. Signal Descriptions (continued)

FUNCTION	SIGNAL NAME	SIGNAL NO. ⁽¹⁾		SIGNAL TYPE ⁽²⁾	DESCRIPTION
		PZ	RGC		
GPIO Port I0	P10.0	100	N/A	I/O	General-purpose digital I/O
	P10.1	1	N/A	I/O	General-purpose digital I/O
	P10.2	2	N/A	I/O	General-purpose digital I/O
	P10.3	3	N/A	I/O	General-purpose digital I/O
	P10.4	24	N/A	I/O	General-purpose digital I/O
	P10.5	25	N/A	I/O	General-purpose digital I/O
GPIO Port J	PJ.0	41	28	I/O	General-purpose digital I/O
	PJ.1	42	29	I/O	General-purpose digital I/O
	PJ.2	85	54	I/O	General-purpose digital I/O
	PJ.3	86	55	I/O	General-purpose digital I/O
	PJ.4	92	61	I/O	General-purpose digital I/O
	PJ.5	93	62	I/O	General-purpose digital I/O
I ² C	UCB0SCL	11	8	I/O	I ² C clock in eUSCI_B0 I ² C mode
	UCB0SDA	10	7	I/O	I ² C data in eUSCI_B0 I ² C mode
	UCB1SCL	79	N/A	I/O	I ² C clock in eUSCI_B1 I ² C mode
	UCB1SDA	78	N/A	I/O	I ² C data in eUSCI_B1 I ² C mode
	UCB3SCL	3	N/A	I/O	I ² C clock in eUSCI_B3 I ² C mode
	UCB3SCL	81	50	I/O	I ² C clock in eUSCI_B3 I ² C mode
	UCB3SDA	2	N/A	I/O	I ² C data in eUSCI_B3 I ² C mode
	UCB3SDA	80	49	I/O	I ² C data in eUSCI_B3 I ² C mode
Port Mapper	PM_C0OUT	89	58	O	Default mapping: Comparator_E0 output
	PM_C1OUT	90	59	O	Default mapping: Comparator_E1 output
	PM_DMAE0	88	57	I	Default mapping: DMA external trigger input
	PM_SMCLK	88	57	O	Default mapping: SMCLK clock output
	PM_TA0.0	91	60	I/O	Default mapping: TA0 CCR0 capture: CCI0A input, compare: Out0
	PM_TA0.1	20	N/A	I/O	Default mapping: TA0 CCR1 capture: CCI1A input, compare: Out1
	PM_TA0.2	21	N/A	I/O	Default mapping: TA0 CCR2 capture: CCI2A input, compare: Out2
	PM_TA0.3	22	N/A	I/O	Default mapping: TA0 CCR3 capture: CCI3A input, compare: Out3
	PM_TA0.4	23	N/A	I/O	Default mapping: TA0 CCR4 capture: CCI4A input, compare: Out4
	PM_TA0CLK	89	58	I	Default mapping: TA0 input clock
	PM_TA1.2	28	N/A	I/O	Default mapping: TA1 CCR2 capture: CCI2A input, compare: Out2
	PM_TA1.3	27	N/A	I/O	Default mapping: TA1 CCR3 capture: CCI3A input, compare: Out3
	PM_TA1.4	26	N/A	I/O	Default mapping: TA1 CCR4 capture: CCI4A input, compare: Out4
	PM_TA1CLK	90	59	I	Default mapping: TA1 input clock

Table 4-3. Signal Descriptions (continued)

FUNCTION	SIGNAL NAME	SIGNAL NO. ⁽¹⁾		SIGNAL TYPE ⁽²⁾	DESCRIPTION
		PZ	RGC		
Port Mapper (continued)	PM_UCA1CLK	17	14	I/O	Default mapping: Clock signal input in eUSCI_A1 SPI slave mode Clock signal output in eUSCI_A1 SPI master mode
	PM_UCA1RXD	18	15	I	Default mapping: Receive data in eUSCI_A1 UART mode
	PM_UCA1SIMO	19	16	I/O	Default mapping: Slave in, master out for eUSCI_A1 SPI mode
	PM_UCA1SOMI	18	15	I/O	Default mapping: Slave out, master in for eUSCI_A1 SPI mode
	PM_UCA1STE	16	13	I/O	Default mapping: Slave transmit enable for eUSCI_A1 SPI mode
	PM_UCA1TXD	19	16	O	Default mapping: Transmit data for eUSCI_A1 UART mode
	PM_UCA2CLK	33	20	I/O	Default mapping: Clock signal input for eUSCI_A2 SPI slave mode Clock signal output for eUSCI_A2 SPI master mode
	PM_UCA2RXD	34	21	I	Default mapping: Receive data for eUSCI_A2 UART mode
	PM_UCA2SIMO	35	22	I/O	Default mapping: Slave in, master out for eUSCI_A2 SPI mode
	PM_UCA2SOMI	34	21	I/O	Default mapping: Slave out, master in for eUSCI_A2 SPI mode
	PM_UCA2STE	32	19	I/O	Default mapping: Slave transmit enable for eUSCI_A2 SPI mode
	PM_UCA2TXD	35	22	O	Default mapping: Transmit data for eUSCI_A2 UART mode
	PM_UCB2CLK	37	24	I/O	Default mapping: Clock signal input for eUSCI_B2 SPI slave mode Clock signal output for eUSCI_B2 SPI master mode
	PM_UCB2SCL	39	26	I	Default mapping: I ² C clock for eUSCI_B2 I ² C mode
	PM_UCB2SDA	38	25	I/O	Default mapping: I ² C data for eUSCI_B2 I ² C mode
	PM_UCB2SIMO	38	25	I/O	Default mapping: Slave in, master out for eUSCI_B2 SPI mode
	PM_UCB2SOMI	39	26	I/O	Default mapping: Slave out, master in for eUSCI_B2 SPI mode
PM_UCB2STE	36	23	I/O	Default mapping: Slave transmit enable for eUSCI_B2 SPI mode	
Power	AVCC1	45	32	–	Analog power supply
	AVCC2	87	56	–	Analog power supply
	AVSS1	43	30	–	Analog ground supply
	AVSS2	84	53	–	Analog ground supply
	AVSS3	40	27	–	Analog ground supply
	DVCC1	13	10	–	Digital power supply
	DVCC2	73	48	–	Digital power supply
	DVSS1	15	12	–	Digital ground supply
	DVSS2	72	47	–	Digital ground supply
	DVSS3	82	51	–	Must be connected to ground
	VCORE ⁽⁵⁾	12	9	–	Regulated core power supply (internal use only, no external current loading)
VSW	14	11	–	DC/DC converter switching output	
RTC	RTCCLK	59	34	O	RTC_C clock calibration output

(5) VCORE is for internal use only. Do not use for external current loading. Connect VCORE to only the recommended capacitor value, C_{VCORE}.

Table 4-3. Signal Descriptions (continued)

FUNCTION	SIGNAL NAME	SIGNAL NO. ⁽¹⁾		SIGNAL TYPE ⁽²⁾	DESCRIPTION
		PZ	RGC		
Reference	VREF+	70	45	O	Internal shared reference voltage positive terminal
	VREF-	71	46	O	Internal shared reference voltage negative terminal
	VeREF+	70	45	I	Positive terminal of external reference voltage to ADC
	VeREF-	71	46	I	Negative terminal of external reference voltage to ADC (recommended to connect to onboard ground)
SPI	UCA0CLK	5	2	I/O	Clock signal input for eUSCI_A0 SPI slave mode Clock signal output for eUSCI_A0 SPI master mode
	UCA0SIMO	7	4	I/O	Slave in, master out for eUSCI_A0 SPI mode
	UCA0SOMI	6	3	I/O	Slave out, master in for eUSCI_A0 SPI mode
	UCA0STE	4	1	I/O	Slave transmit enable for eUSCI_A0 SPI mode
	UCA3CLK	97	N/A	I/O	Clock signal input for eUSCI_A3 SPI slave mode Clock signal output for eUSCI_A3 SPI master mode
	UCA3SIMO	99	N/A	I/O	Slave in, master out for eUSCI_A3 SPI mode
	UCA3SOMI	98	N/A	I/O	Slave out, master in for eUSCI_A3 SPI mode
	UCA3STE	96	N/A	I/O	Slave transmit enable for eUSCI_A3 SPI mode
	UCB0CLK	9	6	I/O	Clock signal input for eUSCI_B0 SPI slave mode Clock signal output for eUSCI_B0 SPI master mode
	UCB0SIMO	10	7	I/O	Slave in, master out for eUSCI_B0 SPI mode
	UCB0SOMI	11	8	I/O	Slave out, master in for eUSCI_B0 SPI mode
	UCB0STE	8	5	I/O	Slave transmit enable for eUSCI_B0 SPI mode
	UCB1CLK	77	N/A	I/O	Clock signal input for eUSCI_B1 SPI slave mode Clock signal output for eUSCI_B1 SPI master mode
	UCB1SIMO	78	N/A	I/O	Slave in, master out for eUSCI_B1 SPI mode
	UCB1SOMI	79	N/A	I/O	Slave out, master in for eUSCI_B1 SPI mode
	UCB1STE	76	N/A	I/O	Slave transmit enable for eUSCI_B1 SPI mode
	UCB3CLK	1 31	18	I/O	Clock signal input for eUSCI_B3 SPI slave mode Clock signal output for eUSCI_B3 SPI master mode
	UCB3SIMO	2 80	49	I/O	Slave in, master out for eUSCI_B3 SPI mode
	UCB3SOMI	3 81	50	I/O	Slave out, master in for eUSCI_B3 SPI mode
UCB3STE	30 100	17	I/O	Slave transmit enable for eUSCI_B3 SPI mode	
System	NMI	83	52	I	External nonmaskable interrupt
	RSTn	83	52	I	External reset (active low)
	SVMHOUT	60	35	O	SVMH output
Thermal	QFN Pad	N/A	Pad	–	QFN package exposed thermal pad. TI recommends connection to VSS.

Table 4-3. Signal Descriptions (continued)

FUNCTION	SIGNAL NAME	SIGNAL NO. ⁽¹⁾		SIGNAL TYPE ⁽²⁾	DESCRIPTION
		PZ	RGC		
Timer	PM_TA1.1	29	N/A	I/O	Default mapping: TA1 CCR1 capture: CCI1A input, compare: Out1
	TA1.0	30	17	I/O	TA1 CCR0 capture: CCI0A input, compare: Out0
	TA2.0	31	18	I/O	TA2 CCR0 capture: CCI0A input, compare: Out0
	TA2.1	70	45	I/O	TA2 CCR1 capture: CCI1A input, compare: Out1
	TA2.2	71	46	I/O	TA2 CCR2 capture: CCI2A input, compare: Out2
	TA2.3	80	49	I/O	TA2 CCR3 capture: CCI3A input, compare: Out3
	TA2.4	81	50	I/O	TA2 CCR4 capture: CCI4A input, compare: Out4
	TA2CLK	58	33	I	TA2 input clock
	TA3.0	24	N/A	I/O	TA3 CCR0 capture: CCI0A input, compare: Out0
	TA3.1	25	N/A	I/O	TA3 CCR1 capture: CCI1A input, compare: Out1
	TA3.2	46	N/A	I/O	TA3 CCR2 capture: CCI2A input, compare: Out2
	TA3.3	74	N/A	I/O	TA3 CCR3 capture: CCI3A input, compare: Out3
	TA3.4	75	N/A	I/O	TA3 CCR4 capture: CCI4A input, compare: Out4
	TA3CLK	47	N/A	I	TA3 input clock
UART	UCA0RXD	6	3	I	Receive data for eUSCI_A0 UART mode
	UCA0TXD	7	4	O	Transmit data for eUSCI_A0 UART mode
	UCA3RXD	98	N/A	I	Receive data for eUSCI_A3 UART mode
	UCA3TXD	99	N/A	O	Transmit data for eUSCI_A3 UART mode

4.5 Pin Multiplexing

Pin multiplexing for these devices is controlled by both register settings and operating modes (for example, if the device is in test mode). For details of the settings for each pin and diagrams of the multiplexed ports, see [Section 6.12](#).

4.6 Buffer Types

[Table 4-4](#) describes the buffer types that are referenced in [Table 4-1](#) and [Table 4-2](#).

Table 4-4. Buffer Type

BUFFER TYPE (STANDARD)	NOMINAL VOLTAGE	HYSTERESIS	PU OR PD	NOMINAL PU OR PD STRENGTH (µA)	OUTPUT DRIVE STRENGTH (mA)	OTHER CHARACTERISTICS
Analog ⁽¹⁾	3.0 V	N	N/A	N/A	N/A	See analog modules in Section 5 for details.
HVCMOS	13.0 V	Y	N/A	N/A	See Section 5.26.6 .	
LVC MOS	3.0 V	Y ⁽²⁾	Programmable	See Section 5.26.6 .	See Section 5.26.6 .	
Power (DVCC) ⁽³⁾	3.0 V	N	N/A	N/A	N/A	SVSMH enables hysteresis on DVCC.
Power (AVCC) ⁽³⁾	3.0 V	N	N/A	N/A	N/A	
Power (DVSS and AVSS) ⁽³⁾	0 V	N	N/A	N/A	N/A	

(1) This is a switch, not a buffer.

(2) Only for input pins.

(3) This is supply input, not a buffer.

4.7 Connections for Unused Pins

Table 4-5 lists the correct termination of all unused pins.

Table 4-5. Connection for Unused Pins ⁽¹⁾

PIN	POTENTIAL	COMMENT
AVCC	DV _{CC}	
AVSS	DV _{SS}	
VSW	Open	Leave VSW pin unconnected if DC/DC regulator operation is not required.
Px.0 to Px.7	Open	Set to port function, output direction, and leave unconnected on the PCB.
RSTn/NMI	DV _{CC} or V _{CC}	47-kΩ pullup with 1.1-nF pulldown
PJ.4/TDI	Open	The JTAG TDI pin is shared with general-purpose I/O function (PJ.4). If not being used, set this pin to port function, output direction. When used as the JTAG TDI pin, leave this pin open.
PJ.5/TDO/SWO	DV _{CC} or V _{CC}	The JTAG TDO/SWO pin is shared with general-purpose I/O function (PJ.5). If not being used, set this pin to port function, output direction. When used as the JTAG TDO/SWO pin, use an external pulldown on this pin.
SWDIOTMS	DV _{CC} or V _{CC}	Use an external pullup on this pin.
SWCLKTCK	DV _{CC} or V _{CC}	Use an external pulldown on this pin.

(1) For any unused pin with a secondary function that is shared with general-purpose I/O, follow the guidelines for the Px.0 to Px.7 pins.

5 Specifications

5.1 Absolute Maximum Ratings⁽¹⁾

over recommended ranges of supply voltage and operating free-air temperature (unless otherwise noted)

	MIN	MAX	UNIT
Voltage applied at DV _{CC} and AV _{CC} pins to V _{SS}	-0.3	4.17	V
Voltage difference between DV _{CC} and AV _{CC} pins ⁽²⁾		±0.3	V
Voltage applied to any pin ⁽³⁾	-0.3	V _{CC} + 0.3 V (4.17 V MAX)	V
Diode current at any device pin		±2	mA
Storage temperature, T _{stg} ⁽⁴⁾	-40	125	°C
Maximum junction temperature, T _J		95	°C

- (1) Stresses beyond those listed under *Absolute Maximum Ratings* may cause permanent damage to the device. These are stress ratings only, and functional operation of the device at these or any other conditions beyond those indicated under *Recommended Operating Conditions* is not implied. Exposure to absolute-maximum-rated conditions for extended periods may affect device reliability.
- (2) Voltage differences between DV_{CC} and AV_{CC} exceeding the specified limits may cause malfunction of the device.
- (3) All voltages referenced to V_{SS}.
- (4) Higher temperature may be applied during board soldering according to the current JEDEC J-STD-020 specification with peak reflow temperatures not higher than classified on the device label on the shipping boxes or reels.

5.2 ESD Ratings

		VALUE	UNIT
V _(ESD) Electrostatic discharge	Human-body model (HBM), per ANSI/ESDA/JEDEC JS-001 ⁽¹⁾ ⁽²⁾	±1000	V
	Charged-device model (CDM), per JEDEC specification JESD22-C101 ⁽³⁾	±250	

- (1) JEDEC document JEP155 states that 500-V HBM allows safe manufacturing with a standard ESD control process. Pins listed as ±1000 V may actually have higher performance.
- (2) All pins pass HBM up to ±1000 V except the DVSS3 pin. The DVSS3 pin is used for TI internal test purposes. Connect the DVSS3 pin to supply ground on the customer application board.
- (3) JEDEC document JEP157 states that 250-V CDM allows safe manufacturing with a standard ESD control process. Pins listed as ±250 V may actually have higher performance.

5.3 Recommended Operating Conditions

Typical data are based on V_{CC} = 3.0 V, T_A = 25°C (unless otherwise noted)

		MIN	NOM	MAX	UNIT
V _{CC} Supply voltage range at all DV _{CC} and AV _{CC} pins ⁽¹⁾ ⁽²⁾ ⁽³⁾	At power up (with internal V _{CC} supervision)	1.71		3.7	V
	Normal operation with internal V _{CC} supervision	1.71		3.7	
	Normal operation without internal V _{CC} supervision	1.62		3.7	
V _{SS} Supply voltage on all DV _{SS} and AV _{SS} pins			0		V
I _{INRUSH} Inrush current into the V _{CC} pins ⁽⁴⁾				100	mA
f _{MCLK} Frequency of the CPU and AHB clock in the system ⁽⁵⁾		0		48	MHz
T _A Operating free-air temperature		-40		85	°C
T _J Operating junction temperature		-40		85	°C

- (1) TI recommends powering AV_{CC} and DV_{CC} from the same source. A maximum difference of ±0.1 V between AV_{CC} and DV_{CC} can be tolerated during power up and operation. See [Section 5.4](#) for decoupling capacitor recommendations.
- (2) Supply voltage must not change faster than 1 V/ms. Faster changes can cause the VCCDET to trigger a reset even within the recommended supply voltage range.
- (3) Modules may have a different supply voltage range specification. See the specification of the respective module in this data sheet.
- (4) Does not include I/O currents (driven by application requirements).
- (5) Operating frequency may require the flash to be accessed with wait states. See [Section 5.8](#) for further details.

5.4 Recommended External Components^{(1) (2) (3)}

			MIN	NOM	MAX	UNIT
C _{DVCC}	Capacitor on DVCC pin	For DC/DC operation ⁽⁴⁾	3.3	4.7		μF
		For LDO-only operation	3.3	4.7		
C _{VCORE}	Capacitor on VCORE pin	For DC/DC operation, including capacitor tolerance	1.54	4.7	9	μF
		For LDO-only operation, including capacitor tolerance	70	100	9000	nF
C _{AVCC}	Capacitor on AVCC pin		3.3	4.7		μF
L _{VSW}	Inductor between VSW and VCORE pins for DC/DC		3.3	4.7	13	μH
R _{L_{VSW}-DCR}	Allowed DCR for L _{VSW}			150	350	mΩ
I _{SAT-L_{VSW}}	L _{VSW} saturation current		700			mA

(1) For optimum performance, select components that match the NOM values in this table.

(2) See [Section 7](#) for more details on component selection, placement, and related PCB design guidelines.

(3) Consider the tolerances of the capacitance and inductance values when choosing components to ensure that the MIN and MAX limits are never exceeded.

(4) C_{DVCC} should not be smaller than C_{VCORE}.

5.5 Operating Mode V_{CC} Ranges

over operating free-air temperature (unless otherwise noted)

PARAMETER	OPERATING MODE	TEST CONDITIONS	MIN	MAX	UNIT
V _{CC_LDO} ^{(1) (2)}	AM_LDO_VCORE0 AM_LF_VCORE0 LPM0_LDO_VCORE0 LPM0_LF_VCORE0 LPM3_VCORE0 LPM4_VCORE0 LPM3.5 AM_LDO_VCORE1 AM_LF_VCORE1 LPM0_LDO_VCORE1 LPM0_LF_VCORE1 LPM3_VCORE1 LPM4_VCORE1	LDO active, SVSMH disabled	1.62	3.7	V
		LDO active, SVSMH enabled	1.71	3.7	
V _{CC_DCDC_DF0}	AM_DCDC_VCORE0 LPM0_DCDC_VCORE0 AM_DCDC_VCORE1 LPM0_DCDC_VCORE1	DC/DC active, DC/DC operation not forced (DCDC_FORCE = 0), SVSMH enabled or disabled ⁽³⁾	2.0	3.7	V
V _{CC_DCDC_DF1}	AM_DCDC_VCORE0 LPM0_DCDC_VCORE0 AM_DCDC_VCORE1 LPM0_DCDC_VCORE1	DC/DC active, DC/DC operation forced (DCDC_FORCE = 1), SVSMH enabled or disabled	1.8	3.7	V
V _{CC_VCORE_OFF} ⁽⁴⁾	LPM4.5	LDO disabled, SVSMH disabled	1.62	3.7	V
		LDO disabled, SVSMH enabled	1.71	3.7	

(1) Flash remains active only in active modes and LPM0 modes.

(2) Low-frequency active and low-frequency LPM0, LPM3, LPM4, and LPM3.5 modes are based on LDO only.

(3) When V_{CC} falls below the specified MIN value, the DC/DC operation automatically switches to LDO, as long as the V_{CC} drop is slower than the rate that is reliably detected. See [Table 5-20](#) for more details.

(4) Core voltage is off in LPM4.5 mode.

5.6 Operating Mode CPU Frequency Ranges⁽¹⁾

over recommended ranges of supply voltage and operating free-air temperature (unless otherwise noted)

PARAMETER	OPERATING MODE	DESCRIPTION	f _{MCLK}		UNIT
			MIN	MAX	
f _{AM_LDO_VCORE0}	AM_LDO_VCORE0	Normal-performance mode with LDO as the active regulator	0	24	MHz
f _{AM_LDO_VCORE1}	AM_LDO_VCORE1	High-performance mode with LDO as the active regulator	0	48	MHz
f _{AM_DCDC_VCORE0}	AM_DCDC_VCORE0	Normal-performance mode with DC/DC as the active regulator	0	24	MHz
f _{AM_DCDC_VCORE1}	AM_DCDC_VCORE1	High-performance mode with DC/DC as the active regulator	0	48	MHz
f _{AM_LF_VCORE0}	AM_LF_VCORE0	Low-frequency mode with LDO as the active regulator	0	128	kHz
f _{AM_LF_VCORE1}	AM_LF_VCORE1	Low-frequency mode with LDO as the active regulator	0	128	kHz

(1) The DMA can be operated at the same frequency as the CPU.

5.7 Operating Mode Peripheral Frequency Ranges

over recommended ranges of supply voltage and operating free-air temperature (unless otherwise noted)

PARAMETER	OPERATING MODE	DESCRIPTION	MIN	MAX	UNIT
f _{AM_LPM0_VCORE0}	AM_LDO_VCORE0	Peripheral frequency range in LDO or DC/DC-based active or LPM0 modes for VCORE0	0	12	MHz
	AM_DCDC_VCORE0				
	LPM0_LDO_VCORE0				
	LPM0_DCDC_VCORE0				
f _{AM_LPM0_VCORE1}	AM_LDO_VCORE1	Peripheral frequency range in LDO or DC/DC-based active or LPM0 modes for VCORE1	0	24	MHz
	AM_DCDC_VCORE1				
	LPM0_LDO_VCORE1				
	LPM0_DCDC_VCORE1				
f _{AM_LPM0_LF}	AM_LF_VCORE0	Peripheral frequency range in low-frequency active or low-frequency LPM0 modes for VCORE0 and VCORE1	0	128	kHz
	AM_LF_VCORE1				
	LPM0_LF_VCORE0				
	LPM0_LF_VCORE1				
f _{LPM3} ⁽¹⁾	LPM3_VCORE0	Peripheral frequency in LPM3 mode for VCORE0 and VCORE1	0	128	kHz
	LPM3_VCORE1				
f _{LPM4} ⁽²⁾	LPM4_VCORE0	Peripheral frequency in LPM4 mode for VCORE0 and VCORE1	0	128	kHz
	LPM4_VCORE1				
f _{LPM3.5} ⁽¹⁾	LPM3.5	Peripheral frequency in LPM3.5 mode	0	32.768	kHz

(1) Only RTC and WDT can be active.

(2) Peripherals available in LPM4 can be operational on external clocks.

5.8 Operating Mode Execution Frequency vs Flash Wait-State Requirements

over recommended ranges of supply voltage and operating free-air temperature (unless otherwise noted)

PARAMETER	NUMBER OF FLASH WAIT STATES	FLASH READ MODE	MAXIMUM SUPPORTED MCLK FREQUENCY ⁽¹⁾ , ⁽²⁾		UNIT
			AM_LDO_VCORE0, AM_DCDC_VCORE0	AM_LDO_VCORE1, AM_DCDC_VCORE1	
f _{MAX_NRM_FLWAIT0}	0	Normal read mode	10	13	MHz
f _{MAX_NRM_FLWAIT1}	1	Normal read mode	21	27	MHz
f _{MAX_NRM_FLWAIT2}	2	Normal read mode	24	40	MHz
f _{MAX_NRM_FLWAIT3}	3	Normal read mode	24	48	MHz
f _{MAX ORM_FLWAIT0}	0	Other read modes ⁽³⁾	6	7	MHz
f _{MAX ORM_FLWAIT1}	1	Other read modes ⁽³⁾	12	14	MHz
f _{MAX ORM_FLWAIT2}	2	Other read modes ⁽³⁾	18	21	MHz
f _{MAX ORM_FLWAIT3}	3	Other read modes ⁽³⁾	24	28	MHz
f _{MAX ORM_FLWAIT4}	4	Other read modes ⁽³⁾	24	35	MHz
f _{MAX ORM_FLWAIT5}	5	Other read modes ⁽³⁾	24	42	MHz
f _{MAX ORM_FLWAIT6}	6	Other read modes ⁽³⁾	24	48	MHz

- (1) Violation of the maximum frequency limitation for a given wait-state configuration results in nondeterministic data or instruction fetches from the flash memory.
- (2) In low-frequency active modes, the flash can always be accessed with 0 wait states, because the maximum MCLK frequency is limited to 128 kHz.
- (3) *Other read modes* refers to Read Margin 0, Read Margin 01, Program Verify, and Erase Verify.

5.9 Current Consumption During Device Reset of the 100-Pin LQFP Package

over recommended ranges of supply voltage and operating free-air temperature (unless otherwise noted)^{(1) (2) (3) (4)}

PARAMETER		V _{CC}	MIN	TYP	MAX	UNIT
I _{RESET}	Current during device reset	2.2 V	690			μA
		3.0 V	760	1000		

- (1) This parameter does not apply to the 64-pin VQFN package.
- (2) Device held in reset through RSTn/NMI pin.
- (3) Current measured into V_{CC}.
- (4) All other input pins tied to 0 V or V_{CC}. Outputs do not source or sink any current.

5.10 Current Consumption in LDO-Based Active Modes – Dhrystone 2.1 Program

over recommended operating free-air temperature (unless otherwise noted)^{(1) (2) (3) (4) (5)}

PARAMETER	EXECUTION MEMORY	V _{CC}	MCLK = 1 MHz		MCLK = 8 MHz		MCLK = 16 MHz		MCLK = 24 MHz		MCLK = 32 MHz		MCLK = 40 MHz		MCLK = 48 MHz		UNIT
			TYP	MAX	TYP	MAX	TYP	MAX	TYP	MAX	TYP	MAX	TYP	MAX	TYP	MAX	
I _{AM_LDO_VCORE0,Flash} ^{(6) (7) (8)}	Flash	3.0 V	700	950	2000	2400	3200	3600	4000	4500							μA
I _{AM_LDO_VCORE1,Flash} ^{(6) (7) (8)}	Flash	3.0 V	720	1050	2150	2600	3520	4000	5000	5600	5700	6300	7000	7600	7300	8200	μA
I _{AM_LDO_VCORE0,SRAM} ⁽⁹⁾	SRAM	3.0 V	640	900	1600	2000	2675	3100	3750	4250							μA
I _{AM_LDO_VCORE1,SRAM} ⁽⁹⁾	SRAM	3.0 V	650	1000	1625	2100	2725	3200	3825	4350	5000	5550	6100	6800	7200	7900	μA

- (1) MCLK sourced by DCO.
- (2) Current measured into V_{CC}.
- (3) All other input pins tied to 0 V or V_{CC}. Outputs do not source or sink any current.
- (4) All SRAM banks are active.
- (5) All peripherals are inactive.
- (6) Device executing the Dhrystone 2.1 program. Code execution from flash, stack, and data in SRAM.
- (7) Flash configured to minimum wait states required to support operation at given frequency and core voltage level.
- (8) Flash instruction and data buffers are enabled (BUFI = BUFD = 1).
- (9) Device executing the Dhrystone 2.1 program. Code execution from SRAM, stack and data in SRAM.

5.11 Current Consumption in DC/DC-Based Active Modes – Dhrystone 2.1 Program

over recommended operating free-air temperature (unless otherwise noted)^{(1) (2) (3) (4) (5)}

PARAMETER	EXECUTION MEMORY	V _{CC}	MCLK = 1 MHz		MCLK = 8 MHz		MCLK = 16 MHz		MCLK = 24 MHz		MCLK = 32 MHz		MCLK = 40 MHz		MCLK = 48 MHz		UNIT
			TYP	MAX	TYP	MAX	TYP	MAX	TYP	MAX	TYP	MAX	TYP	MAX	TYP	MAX	
I _{AM_DCDC_VCORE0,Flash} ^{(6) (7) (8)}	Flash	3.0 V	580	800	1280	1750	1970	2300	2390	2900							μA
I _{AM_DCDC_VCORE1,Flash} ^{(6) (7) (8)}	Flash	3.0 V	620	900	1490	1850	2325	2750	3250	3800	3650	4250	4450	5100	4650	5300	μA
I _{AM_DCDC_VCORE0,SRAM} ⁽⁹⁾	SRAM	3.0 V	550	750	1040	1400	1600	2000	2170	2650							μA
I _{AM_DCDC_VCORE1,SRAM} ⁽⁹⁾	SRAM	3.0 V	580	850	1150	1550	1790	2200	2440	2900	3100	3650	3770	4400	4400	5100	μA

- (1) MCLK sourced by DCO.
- (2) Current measured into V_{CC}.
- (3) All other input pins tied to 0 V or V_{CC}. Outputs do not source or sink any current.
- (4) All SRAM banks are active.
- (5) All peripherals are inactive.
- (6) Device executing the Dhrystone 2.1 program. Code execution from flash. Stack and data in SRAM.
- (7) Flash configured to minimum wait states required to support operation at given frequency and core voltage level.
- (8) Flash instruction and data buffers are enabled (BUFI = BUFD = 1).
- (9) Device executing the Dhrystone 2.1 program. Code execution from SRAM. Stack and data in SRAM.

5.12 Current Consumption in Low-Frequency Active Modes – Dhrystone 2.1 Program

over recommended ranges of supply voltage and operating free-air temperature (unless otherwise noted)^{(1) (2) (3) (4) (5)}

PARAMETER	EXECUTION MEMORY	V _{CC}	–40°C		25°C		60°C		85°C		UNIT
			TYP	MAX	TYP	MAX	TYP	MAX	TYP	MAX	
I _{AM_LF_VCORE0, flash} ^{(6) (7) (8)}	Flash	2.2 V	90		95		110		140		μA
		3.0 V	90		95	120	110		150	350	
I _{AM_LF_VCORE1, flash} ^{(6) (7) (8)}	Flash	2.2 V	92		100		120		160		μA
		3.0 V	95		110	150	130		200	500	
I _{AM_LF_VCORE0, SRAM} ⁽⁹⁾	SRAM	2.2 V	88		95		110		140		μA
		3.0 V	88		95	115	110		150	300	
I _{AM_LF_VCORE1, SRAM} ⁽⁹⁾	SRAM	2.2 V	92		98		118		165		μA
		3.0 V	93		100	130	120		166	400	

(1) Current measured into V_{CC}.

(2) All other input pins tied to 0 V or V_{CC}. Outputs do not source or sink any current.

(3) MCLK sourced by REFO at 128 kHz.

(4) All peripherals are inactive.

(5) SRAM banks 0 and 1 enabled for execution from flash, and SRAM banks 0 to 3 enabled for execution from SRAM.

(6) Flash configured to 0 wait states.

(7) Device executing the Dhrystone 2.1 program. Code execution from Flash. Stack and data in SRAM.

(8) Flash instruction and data buffers are enabled (BUFI = BUFD = 1).

(9) Device executing the Dhrystone 2.1 program. Code execution from SRAM. Stack and data also in SRAM.

5.13 Typical Characteristics of Active Mode Currents for CoreMark Program

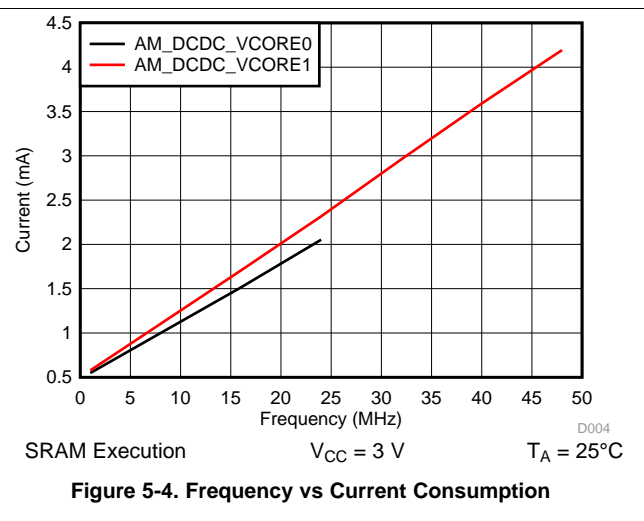
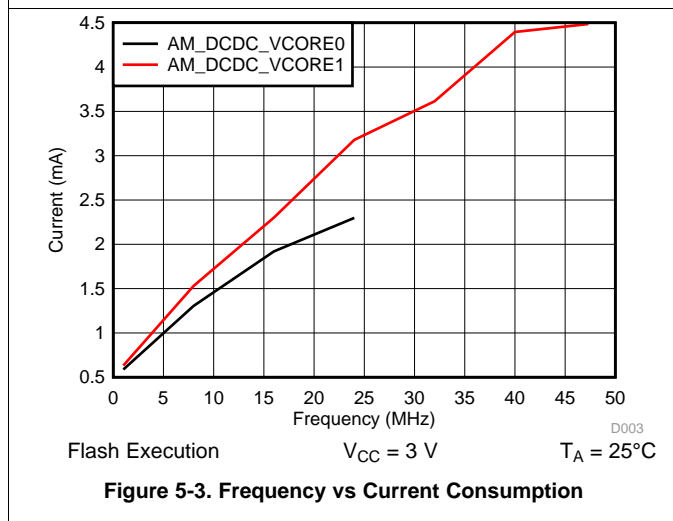
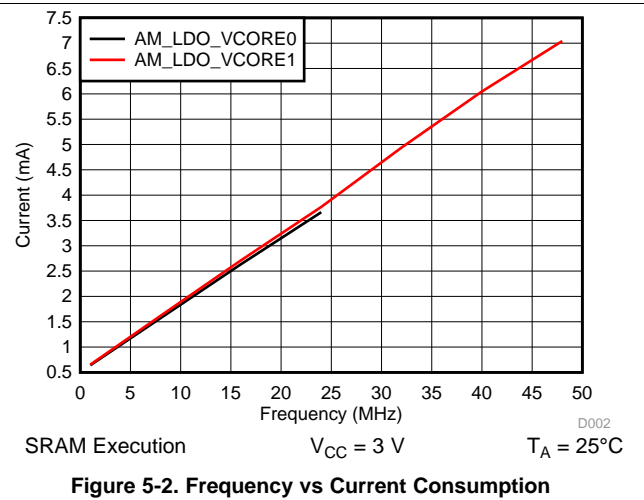
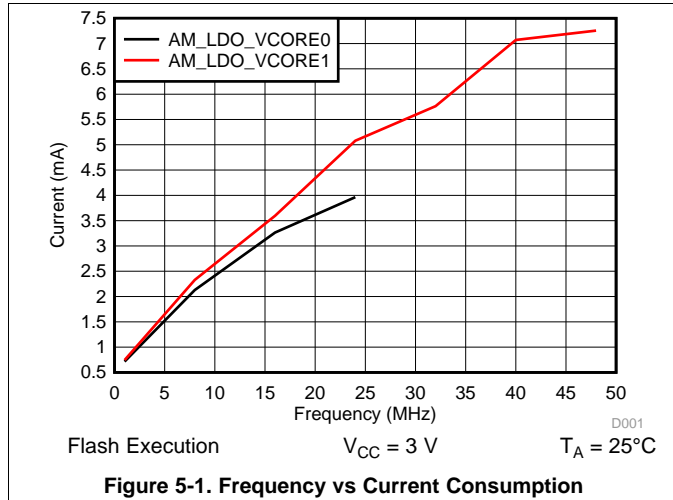

5.14 Typical Characteristics of Active Mode Currents for Prime Number Program

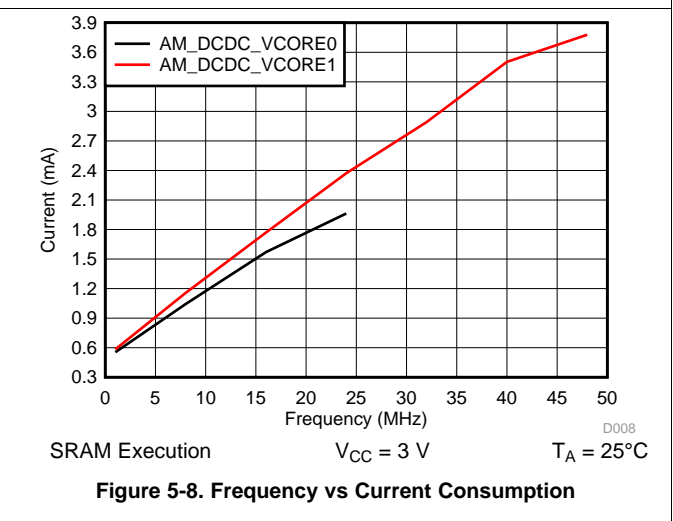
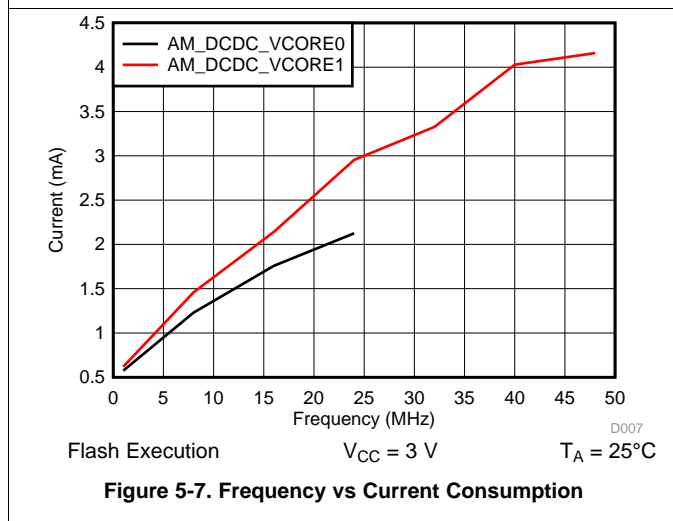
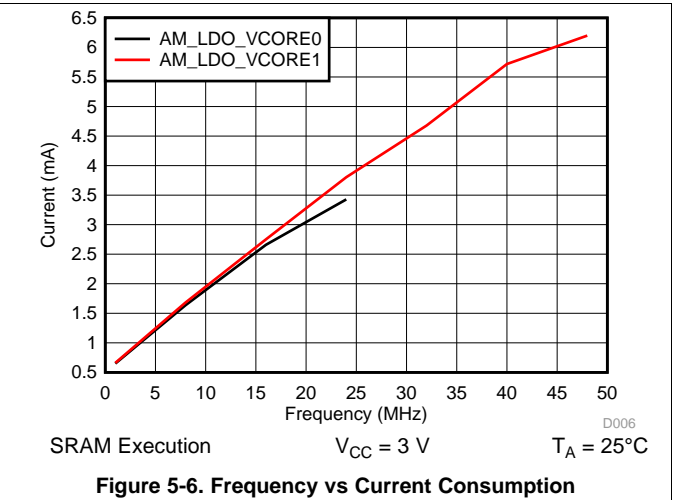
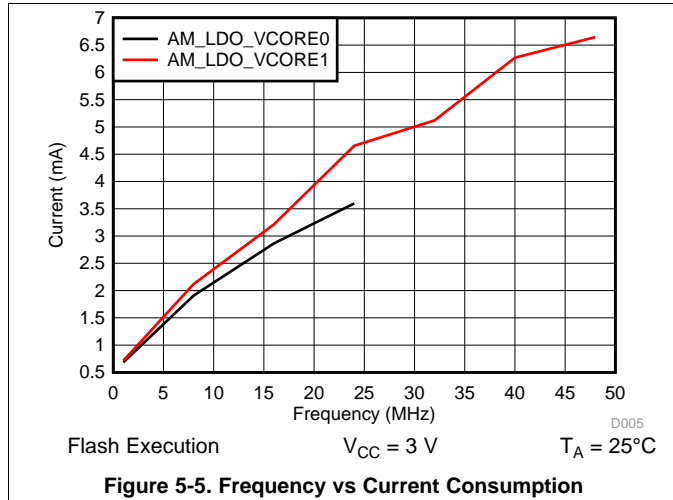

5.15 Typical Characteristics of Active Mode Currents for Fibonacci Program

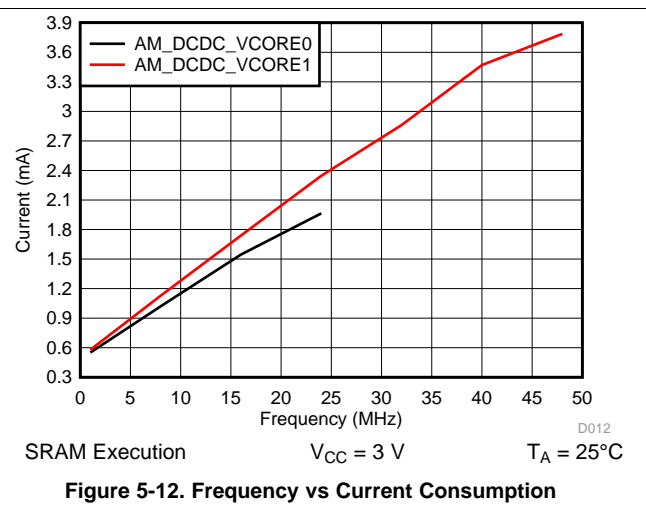
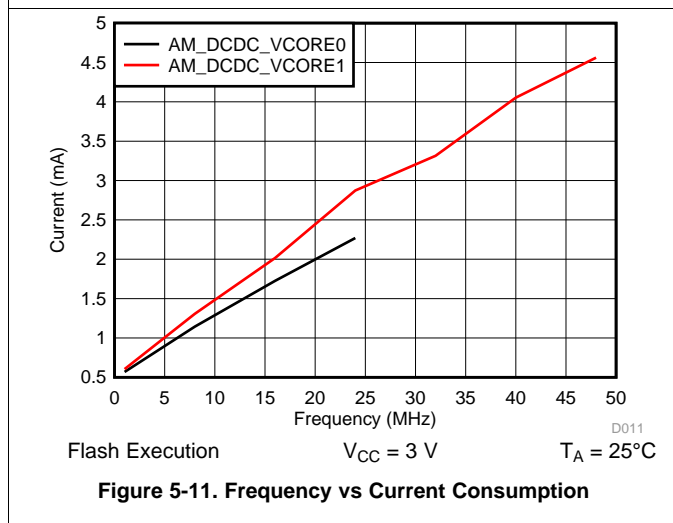
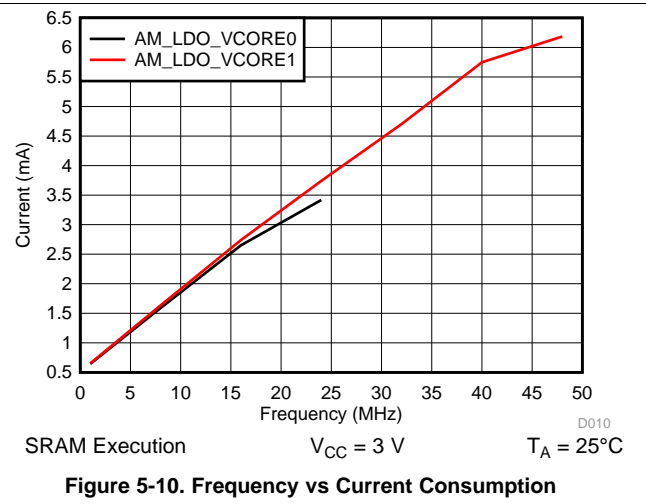
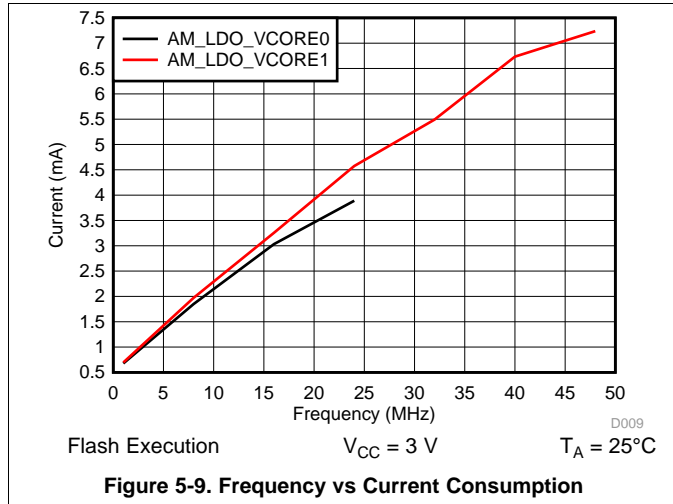

5.16 Typical Characteristics of Active Mode Currents for While(1) Program

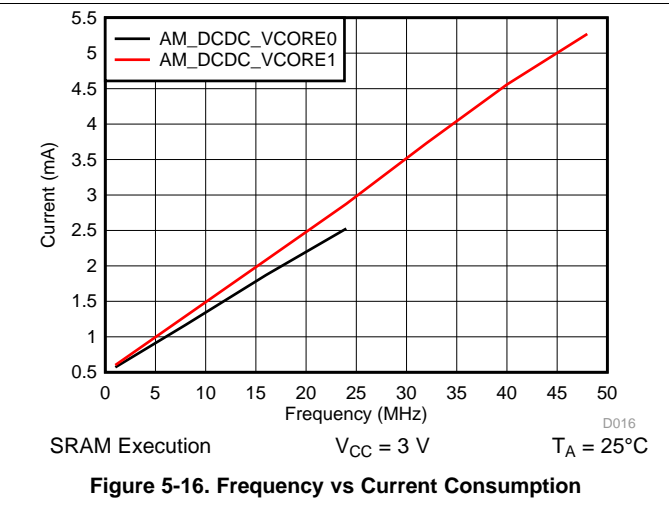
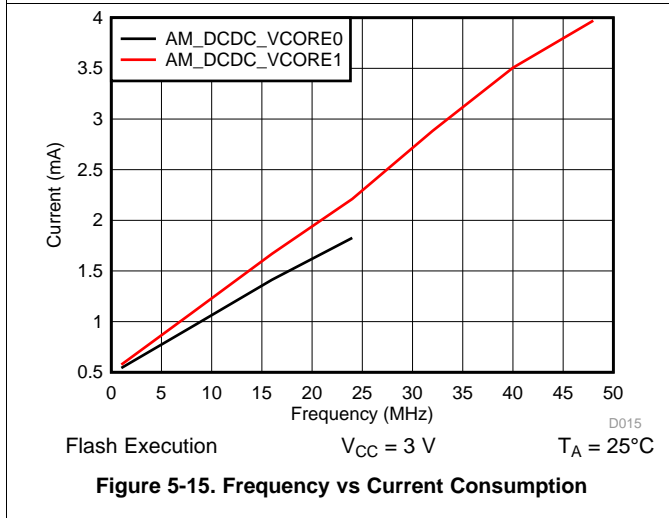
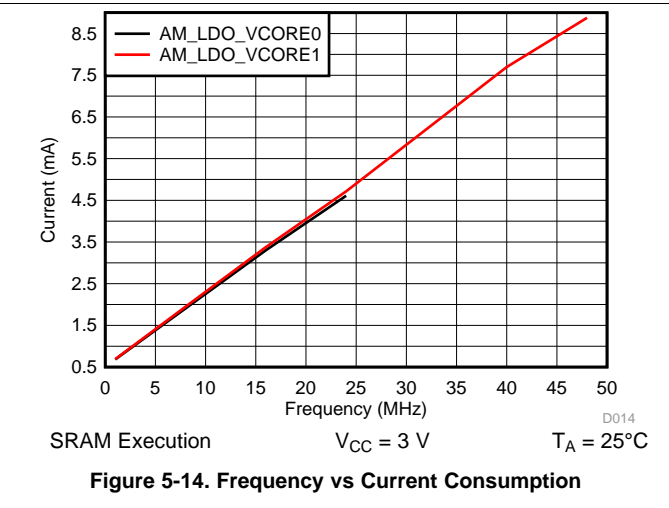
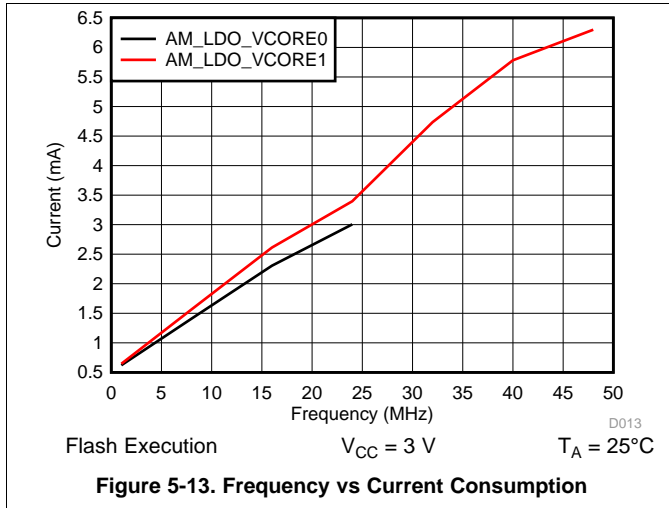

5.17 Typical Characteristics of Low-Frequency Active Mode Currents for CoreMark Program

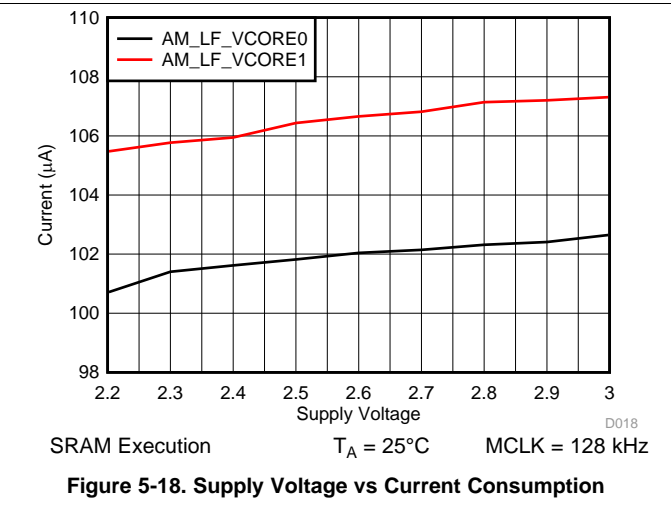
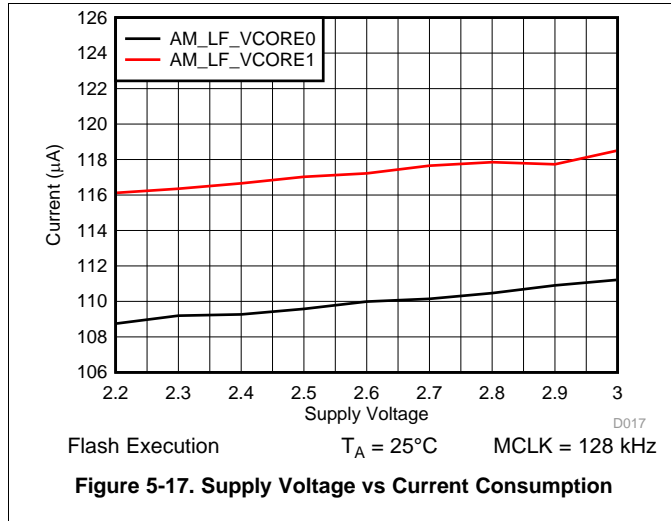

5.18 Current Consumption in LDO-Based LPM0 Modes

over recommended operating free-air temperature (unless otherwise noted)^{(1) (2) (3) (4) (5) (6)}

PARAMETER	V _{CC}	MCLK = 1 MHz		MCLK = 8 MHz		MCLK = 16 MHz		MCLK = 24 MHz		MCLK = 32 MHz		MCLK = 40 MHz		MCLK = 48 MHz		UNIT
		TYP	MAX	TYP	MAX	TYP	MAX	TYP	MAX	TYP	MAX	TYP	MAX	TYP	MAX	
I _{LPM0_LDO_VCORE0}	2.2 V	520	750	610	850	710	950	810	1050							μA
	3.0 V	520	750	610	850	710	950	810	1050							
I _{LPM0_LDO_VCORE1}	2.2 V	525	800	630	900	750	1050	860	1200	1025	1350	1160	1500	1240	1600	μA
	3.0 V	525	800	630	900	750	1050	860	1200	1025	1350	1160	1500	1240	1600	

- (1) MCLK sourced by DCO.
- (2) Current measured into V_{CC}.
- (3) All other input pins tied to 0 V or V_{CC}. Outputs do not source or sink any current.
- (4) CPU is off, flash or SRAM not being accessed.
- (5) All SRAM banks are active.
- (6) All peripherals are inactive.

5.19 Current Consumption in DC/DC-Based LPM0 Modes

over recommended operating free-air temperature (unless otherwise noted)^{(1) (2) (3) (4) (5) (6)}

PARAMETER	V _{CC}	MCLK = 1 MHz		MCLK = 8 MHz		MCLK = 16 MHz		MCLK = 24 MHz		MCLK = 32 MHz		MCLK = 40 MHz		MCLK = 48 MHz		UNIT
		TYP	MAX	TYP	MAX	TYP	MAX	TYP	MAX	TYP	MAX	TYP	MAX	TYP	MAX	
I _{LPM0_DCDC_VCORE0}	2.2 V	490	700	550	750	620	850	700	950							μA
	3.0 V	485	650	535	700	585	750	650	850							
I _{LPM0_DCDC_VCORE1}	2.2 V	510	750	590	850	680	950	775	1050	900	1200	1010	1300	1080	1400	μA
	3.0 V	505	700	570	800	635	850	715	950	815	1050	900	1150	960	1200	

- (1) MCLK sourced by DCO.
- (2) Current measured into V_{CC}.
- (3) All other input pins tied to 0 V or V_{CC}. Outputs do not source or sink any current.
- (4) CPU is off, flash or SRAM not being accessed.
- (5) All SRAM banks are active.
- (6) All peripherals are inactive.

5.20 Current Consumption in Low-Frequency LPM0 Modes

over recommended ranges of supply voltage and operating free-air temperature (unless otherwise noted)^{(1) (2) (3) (4) (5) (6)}

PARAMETER	V _{CC}	-40°C		25°C		60°C		85°C		UNIT
		TYP	MAX	TYP	MAX	TYP	MAX	TYP	MAX	
I _{LPM0_LF_VCORE0}	2.2 V	73		77		87		113		μA
	3.0 V	73		77	100	87		113	200	
I _{LPM0_LF_VCORE1}	2.2 V	75		80		92		122		μA
	3.0 V	75		80	100	92		122	250	

- (1) Current measured into V_{CC}.
- (2) All other input pins tied to 0 V or V_{CC}. Outputs do not source or sink any current.
- (3) MCLK sourced by REFO at 128 kHz.
- (4) All peripherals are inactive.
- (5) Bank 0 of SRAM are active. Rest of the banks are powered down.
- (6) CPU is off, flash or SRAM not being accessed.

5.21 Current Consumption in LPM3, LPM4 Modes

over recommended ranges of supply voltage and operating free-air temperature (unless otherwise noted) ⁽¹⁾ ⁽²⁾ ⁽³⁾ ⁽⁴⁾ ⁽⁵⁾ ⁽⁶⁾

PARAMETER	V _{CC}	-40°C		25°C		60°C		85°C		UNIT
		TYP	MAX	TYP	MAX	TYP	MAX	TYP	MAX	
I _{LPM3_VCORE0_RTCLF} ⁽⁷⁾ ⁽⁸⁾	2.2 V	0.64		0.79		1.38		2.90		μA
	3.0 V	0.66		0.82		1.41		3.10		
I _{LPM3_VCORE0_RTCREFO} ⁽⁹⁾ ⁽⁸⁾	2.2 V	0.98		1.27		1.93		3.50		μA
	3.0 V	1.10		1.36	3.80	2.00		3.70	8.00	
I _{LPM3_VCORE1_RTCLF} ⁽⁷⁾ ⁽⁸⁾	2.2 V	0.91		1.17		1.91		3.80		μA
	3.0 V	0.94		1.20		1.95		3.85		
I _{LPM3_VCORE1_RTCREFO} ⁽⁹⁾ ⁽⁸⁾	2.2 V	1.27		1.63		2.38		4.30		μA
	3.0 V	1.33		1.69		2.58		4.85		
I _{LPM4_VCORE0} ⁽¹⁰⁾	2.2 V	0.50		0.66		1.04		3.10		μA
	3.0 V	0.53		0.69		1.07		3.10		
I _{LPM4_VCORE1} ⁽¹⁰⁾	2.2 V	0.65		0.90		1.74		4.01		μA
	3.0 V	0.67		0.92		1.77		4.05		
I _{IDLE, PG1, VCORE0}	2.2 V	0.22		0.34		0.92		2.42		μA
	3.0 V	0.22		0.34		0.93		2.43		
I _{IDLE, PG1, VCORE1}	2.2 V	0.35		0.53		1.27		3.07		μA
	3.0 V	0.35		0.53		1.28		3.08		
I _{IDLE, PG2, VCORE0}	2.2 V	0.25		0.40		1.15		3.08		μA
	3.0 V	0.25		0.41		1.15		3.09		
I _{IDLE, PG2, VCORE1}	2.2 V	0.41		0.65		1.61		3.96		μA
	3.0 V	0.41		0.65		1.61		3.96		
I _{IDLE, PG3, VCORE0}	2.2 V	0.28		0.45		1.27		3.40		μA
	3.0 V	0.28		0.45		1.27		3.41		
I _{IDLE, PG3, VCORE1}	2.2 V	3.53		3.74		5.45		8.38		μA
	3.0 V	3.53		3.75		5.45		8.38		

- (1) Current measured into V_{CC}.
- (2) All other input pins tied to 0 V or V_{CC}. Outputs do not source or sink any current.
- (3) CPU is off, flash powered down.
- (4) Bank 0 of SRAM retained, all other banks powered down.
- (5) See [Table 5-51](#) for details on additional current consumed for each extra Bank that is enabled for retention.
- (6) SVSMH is disabled.
- (7) RTC sourced by LFXT. Effective load capacitance of LF crystal is 3.7 pF.
- (8) WDT module is disabled.
- (9) RTC sourced by REFO.
- (10) RTC and WDT modules disabled.

5.22 Current Consumption in LPM3 Modes With LCD

over operating free-air temperature range (unless otherwise noted) ⁽¹⁾ ⁽²⁾ ⁽³⁾ ⁽⁴⁾ ⁽⁵⁾ ⁽⁶⁾

PARAMETER	V _{CC}	–40°C		25°C		60°C		85°C		UNIT
		TYP	MAX	TYP	MAX	TYP	MAX	TYP	MAX	
I _{LPM3_VCORE0_LCDEXT} ⁽⁷⁾ ⁽⁸⁾ ⁽⁹⁾	2.4 V	1.24		1.60		3.16		7.29		μA
	3.0 V	1.27		1.63		3.18		7.32		
I _{LPM3_VCORE0_LCDINT} ⁽⁷⁾ ⁽⁸⁾ ⁽¹⁰⁾	2.4 V	1.61		1.98		3.53		7.68		μA
	3.0 V	1.64		2.00		3.56		7.70		
I _{LPM3_VCORE1_LCDEXT} ⁽⁷⁾ ⁽⁸⁾ ⁽⁹⁾	2.4 V	4.60		5.44		7.97		13.15		μA
	3.0 V	4.64		5.47		7.99		13.19		
I _{LPM3_VCORE1_LCDINT} ⁽⁷⁾ ⁽⁸⁾ ⁽¹⁰⁾	2.4 V	5.00		5.86		8.35		13.55		μA
	3.0 V	5.04		5.89		8.38		13.59		

- (1) Current measured into V_{CC}.
- (2) All other input pins tied to 0 V or V_{CC}. Outputs do not source or sink any current.
- (3) CPU is off, flash powered down.
- (4) Block 0 of SRAM retained, all other blocks and banks powered down.
- (5) See [Table 5-51](#) for details on additional current consumed for each extra block that is enabled for retention.
- (6) SVSMH is disabled.
- (7) RTC sourced by LFXT. Effective load capacitance of LF crystal is 3.7 pF.
- (8) WDT module is disabled.
- (9) LCDMx = 11 (4-mux mode), LCDREXT = 1, LCDEXTBIAS = 1 (external biasing), LCD2B = 0 (1/3 bias), LCDSSEL = 0, LCDPREx = 101, LCDDIVx = 00011 (f_{LCD} = 32768 Hz / 32 / 4 = 256 Hz). Current through external resistors not included (voltage levels are supplied by test equipment). Even segments S0, S2,... = 0, odd segments S1, S3,... = 1. No LCD panel load.
- (10) LCDMx = 11 (4-mux mode), LCDREXT = 0, LCDEXTBIAS = 0 (internal biasing), LCD2B = 0 (1/3 bias), LCDSSEL = 0, LCDPREx = 101, LCDDIVx = 00011 (f_{LCD} = 32768 Hz / 32 / 4 = 256 Hz) Even segments S0, S2,... = 0, odd segments S1, S3,... = 1. No LCD panel load.

5.23 Current Consumption in LPM3.5, LPM4.5 Modes

over recommended ranges of supply voltage and operating free-air temperature (unless otherwise noted) ⁽¹⁾ ⁽²⁾

PARAMETER	V _{CC}	–40°C		25°C		60°C		85°C		UNIT
		TYP	MAX	TYP	MAX	TYP	MAX	TYP	MAX	
I _{LPM3.5_RTCLF} ⁽³⁾ ⁽⁴⁾ ⁽⁵⁾ ⁽⁶⁾ ⁽⁷⁾	2.2 V	0.64		0.79		1.38		2.90		μA
	3.0 V	0.66		0.82		1.41		3.10		
I _{LPM3.5_RTCREFO} ⁽³⁾ ⁽⁴⁾ ⁽⁸⁾ ⁽⁶⁾ ⁽⁷⁾	2.2 V	0.98		1.27		1.93		3.50		μA
	3.0 V	1.10		1.36		2.00		3.70		
I _{LPM4.5} ⁽⁹⁾ ⁽⁷⁾	2.2 V	13		19		62		207		nA
	3.0 V	14		22	500	69		229	1200	

- (1) Current measured into V_{CC}.
- (2) All other input pins tied to 0 V or V_{CC}. Outputs do not source or sink any current.
- (3) CPU and flash are powered down.
- (4) Bank 0 of SRAM retained, all other banks powered down.
- (5) RTC sourced by LFXT. Effective load capacitance of LF crystal is 3.7 pF.
- (6) WDT module is disabled.
- (7) SVSMH is disabled.
- (8) RTC sourced by REFO.
- (9) No core voltage. CPU, flash and all banks of SRAM powered down.

5.24 Current Consumption of Digital Peripherals

over recommended ranges of supply voltage and operating free-air temperature (unless otherwise noted)⁽¹⁾

PARAMETER	TEST CONDITIONS	TYP	MAX	UNIT
I _{TIMER_A}	Timer_A configured as PWM timer with 50% duty cycle	5		μA/MHz
I _{TIMER32}	Timer32 enabled	3.5		μA/MHz
I _{UART}	eUSCI_A configured in UART mode	6.5		μA/MHz
I _{SPI}	eUSCI_A configured in SPI master mode	5		μA/MHz
I _{I2C}	eUSCI_B configured in I ² C master mode	5		μA/MHz
I _{WDT_A}	WDT_A configured in interval timer mode	6		μA/MHz
I _{RTC_C}	RTC_C enabled and sourced from 32-kHz LFXT	100		nA
I _{AES256}	AES256 active	19		μA/MHz
I _{CRC32}	CRC32 active	2		μA/MHz

(1) Measured with V_{CORE} = 1.2 V.

5.25 Thermal Resistance Characteristics

over recommended ranges of supply voltage and operating free-air temperature (unless otherwise noted)

THERMAL METRIC ⁽¹⁾		PACKAGE	VALUE ^{(2) (3)}	UNIT
R _{θJA}	Junction-to-ambient thermal resistance, still air	LQFP-100 (PZ)	44.5	°C/W
R _{θJC(TOP)}	Junction-to-case (top) thermal resistance		6.4	°C/W
R _{θJB}	Junction-to-board thermal resistance		22.0	°C/W
Ψ _{JB}	Junction-to-board thermal characterization parameter		21.7	°C/W
Ψ _{JT}	Junction-to-top thermal characterization parameter		0.2	°C/W
R _{θJC(BOTTOM)}	Junction-to-case (bottom) thermal resistance		N/A	°C/W
R _{θJA}	Junction-to-ambient thermal resistance, still air	QFN-64 (RGC)	28.2	°C/W
R _{θJC(TOP)}	Junction-to-case (top) thermal resistance		7.7	°C/W
R _{θJB}	Junction-to-board thermal resistance		6.8	°C/W
Ψ _{JB}	Junction-to-board thermal characterization parameter		6.7	°C/W
Ψ _{JT}	Junction-to-top thermal characterization parameter		0.1	°C/W
R _{θJC(BOTTOM)}	Junction-to-case (bottom) thermal resistance		0.7	°C/W

(1) For more information about traditional and new thermal metrics, see [Semiconductor and IC Package Thermal Metrics](#).

(2) These values are based on a JEDEC-defined 2S2P system (with the exception of the Theta JC (R_{θJC}) value, which is based on a JEDEC-defined 1S0P system) and will change based on environment and application. For more information, see these EIA/JEDEC standards:

- JESD51-2, *Integrated Circuits Thermal Test Method Environmental Conditions - Natural Convection (Still Air)*
- JESD51-3, *Low Effective Thermal Conductivity Test Board for Leaded Surface Mount Packages*
- JESD51-7, *High Effective Thermal Conductivity Test Board for Leaded Surface Mount Packages*
- JESD51-9, *Test Boards for Area Array Surface Mount Package Thermal Measurements*

(3) N/A = Not applicable

5.26 Timing and Switching Characteristics

5.26.1 Reset Timing

Table 5-1 lists the latencies to recover from different types of resets.

Table 5-1. Reset Recovery Latencies

over recommended ranges of supply voltage and operating free-air temperature (unless otherwise noted) ⁽¹⁾

PARAMETER		MIN	TYP	MAX	UNIT
t_{SOFT}	Latency from release of soft reset to first CPU instruction fetch		5		MCLK cycles
t_{HARD}	Latency from release of hard reset to release of soft reset		25		MCLK cycles
t_{POR}	Latency from release of device POR to release of hard reset		15	25	μ s
$t_{COLDPWR, 100nF}$	Latency from a cold power-up condition to release of device POR, $C_{V_{CORE}} = 100$ nF		300	400	μ s
$t_{COLDPWR, 4.7\mu F}$	Latency from a cold power-up condition to release of device POR, $C_{V_{CORE}} = 4.7$ μ F		400	500	μ s

(1) See Section 6.8.1 for details on the various classes of resets on the device

Table 5-2 lists the latencies to recover from an external reset applied on RSTn pin.

Table 5-2. External Reset Recovery Latencies⁽¹⁾

over recommended ranges of supply voltage and operating free-air temperature (unless otherwise noted)

PARAMETER	TEST CONDITIONS	MIN	MAX	UNIT
t_{AM_RSTn}	External reset applied when device is in LDO-based or DC/DC-based active modes, MCLK = 1 to 48 MHz		4.5	ms
$t_{AMLF_RSTn, 128\text{ kHz}}$	External reset applied when device is in low-frequency active modes, MCLK = 128 kHz		5	ms
$t_{AMLF_RSTn, 32\text{ kHz}}$	External reset applied when device is in low-frequency active modes, MCLK = 32.768 kHz		6	ms
t_{LPM0_RSTn}	External reset applied when device is in LDO-based or DC/DC-based LPM0 modes, MCLK = 1 to 48 MHz		4.5	ms
$t_{LPM0LF_RSTn, 128\text{ kHz}}$	External reset applied when device is in low-frequency LPM0 modes, MCLK = 128 kHz		5	ms
$t_{LPM0LF_RSTn, 32\text{ kHz}}$	External reset applied when device is in low-frequency LPM0 modes, MCLK = 32.768 kHz		6	ms
$t_{LPM3_LPM4_RSTn}$	External reset applied when device is in LPM3 or LPM4 modes, MCLK = 24 or 48 MHz while entering LPM3 or LPM4 modes		4.5	ms
$t_{LPMx.5_RSTn}$	External reset applied when device is in LPM3.5 or LPM4.5 modes		4.5	ms

(1) External reset is applied on RSTn pin, and the latency is measured from release of external reset to start of user application code.

5.26.2 Peripheral Register Access Timing

Table 5-3 lists the latency involved when CPU performs read or write access to peripheral registers.

Table 5-3. Peripheral Register Access Latency

over recommended ranges of supply voltage and operating free-air temperature (unless otherwise noted)

PARAMETER		MIN	MAX	UNIT
t_{reg_access}	Number of CPU clock cycles required for read or write access to peripheral registers	2 ⁽¹⁾	5 ⁽²⁾	MCLK cycles

(1) The bridge that connects CPU to peripherals runs at half of the speed of the CPU.

(2) The maximum value depends on the previous opcode executing in the CPU pipeline and the status of the bus (idle or busy performing data access).

5.26.3 Mode Transition Timing

Table 5-4 lists the latencies required to change between different active modes.

Table 5-4. Active Mode Transition Latencies

over recommended ranges of supply voltage and operating free-air temperature (unless otherwise noted)

PARAMETER	ORIGINAL OPERATING MODE	FINAL OPERATING MODE	TEST CONDITIONS	TYP	MAX	UNIT
t _{OFF_AMLDO0}	Power Off	AM_LDO_VCORE0	From V _{CC} reaching 1.71 V to start of user application code		6	ms
t _{AMLDO0_AMLDO1}	AM_LDO_VCORE0	AM_LDO_VCORE1	Transition from AM_LDO_VCORE0 to AM_LDO_VCORE1, MCLK frequency = 24 MHz	300	350	μs
t _{AMLDO1_AMLDO0}	AM_LDO_VCORE1	AM_LDO_VCORE0	Transition from AM_LDO_VCORE1 to AM_LDO_VCORE0, MCLK frequency = 24 MHz	4	5	μs
t _{AMLDO0_AMDCDC0}	AM_LDO_VCORE0	AM_DCDC_VCORE0	Transition from AM_LDO_VCORE0 to AM_DCDC_VCORE0, MCLK frequency = 24 MHz	20	30	μs
t _{AMDCDC0_AMLDO0}	AM_DCDC_VCORE0	AM_LDO_VCORE0	Transition from AM_DCDC_VCORE0 to AM_LDO_VCORE0, MCLK frequency = 24 MHz	10	15	μs
t _{AMLDO1_AMDCDC1}	AM_LDO_VCORE1	AM_DCDC_VCORE1	Transition from AM_LDO_VCORE1 to AM_DCDC_VCORE1, MCLK frequency = 48 MHz	20	30	μs
t _{AMDCDC1_AMLDO1}	AM_DCDC_VCORE1	AM_LDO_VCORE1	Transition from AM_DCDC_VCORE1 to AM_LDO_VCORE1, MCLK frequency = 48 MHz	10	15	μs
t _{AMLDO0_AMLF0}	AM_LDO_VCORE0	AM_LF_VCORE0	Transition from AM_LDO_VCORE0 to AM_LF_VCORE0, SELM = 2, REFO frequency = 128 kHz	90	100	μs
t _{AMLF0_AMLDO0}	AM_LF_VCORE0	AM_LDO_VCORE0	Transition from AM_LF_VCORE0 to AM_LDO_VCORE0, SELM = 2, REFO frequency = 128 kHz	50	60	μs
t _{AMLDO1_AMLF1}	AM_LDO_VCORE1	AM_LF_VCORE1	Transition from AM_LDO_VCORE1 to AM_LF_VCORE1, SELM = 2, REFO frequency = 128 kHz	90	100	μs
t _{AMLF1_AMLDO1}	AM_LF_VCORE1	AM_LDO_VCORE1	Transition from AM_LF_VCORE1 to AM_LDO_VCORE1, SELM = 2, REFO frequency = 128 kHz	50	60	μs

Table 5-5 lists the latencies required to change between different active and LPM0 modes.

Table 5-5. LPM0 Mode Transition Latencies

over recommended ranges of supply voltage and operating free-air temperature (unless otherwise noted)

PARAMETER	ORIGINAL OPERATING MODE	FINAL OPERATING MODE	TEST CONDITIONS	TYP	MAX	UNIT
$t_{\text{AMLDOx_LPM0LDOx}}^{(1)}$	AM_LDO_VCOREx	LPM0_LDO_VCOREx	Transition from AM_LDO_VCORE0 or AM_LDO_VCORE1 to LPM0_LDO_VCORE0 or LPM0_LDO_VCORE1	1		MCLK cycles
$t_{\text{LPM0LDOx_AMLDOx}}^{(2)}$	LPM0_LDO_VCOREx	AM_LDO_VCOREx	Transition from LPM0_LDO_VCORE0 or LPM0_LDO_VCORE1 to AM_LDO_VCORE0 or AM_LDO_VCORE1 through I/O interrupt	3	4	MCLK cycles
$t_{\text{AMDCCDcx_LPM0DCCDcx}}^{(1)}$	AM_DCDC_VCOREx	LPM0_DCDC_VCOREx	Transition from AM_DCDC_VCORE0 or AM_DCDC_VCORE1 to LPM0_DCDC_VCORE0 or LPM0_DCDC_VCORE1	1		MCLK cycles
$t_{\text{LPM0DCCDcx_AMDCCDcx}}^{(2)}$	LPM0_DCDC_VCOREx	AM_DCDC_VCOREx	Transition from LPM0_DCDC_VCORE0 or LPM0_DCDC_VCORE1 to AM_DCDC_VCORE0 or AM_DCDC_VCORE1 through I/O interrupt	3	4	MCLK cycles
$t_{\text{AMLFX_LPM0LFX}}^{(1)}$	AM_LF_VCOREx	LPM0_LF_VCOREx	Transition from AM_LF_VCORE0 or AM_LF_VCORE1 to LPM0_LF_VCORE0 or LPM0_LF_VCORE1	1		MCLK cycles
$t_{\text{LPM0LFX_AMLFX}}^{(2)}$	LPM0_LF_VCOREx	AM_LF_VCOREx	Transition from LPM0_LF_VCORE0 or LPM0_LF_VCORE1 to AM_LF_VCORE0 or AM_LF_VCORE1 through I/O interrupt	3	4	MCLK cycles

(1) This is the latency between execution of WFI instruction by CPU to assertion of SLEEPING signal at CPU output.

(2) This is the latency between I/O interrupt event to deassertion of SLEEPING signal at CPU output.

Table 5-6 lists the latencies required to change between different active modes and LPM3 or LPM4 modes.

Table 5-6. LPM3, LPM4 Mode Transition Latencies

over recommended ranges of supply voltage and operating free-air temperature (unless otherwise noted)

PARAMETER	ORIGINAL OPERATING MODE	FINAL OPERATING MODE	TEST CONDITIONS	TYP	MAX	UNIT
$t_{\text{AMLDO0_LPMx0}}^{(1)}$	AM_LDO_VCORE0	LPM3_LPM4_VCORE0	Transition from AM_LDO_VCORE0 to LPM3 or LPM4 at VCORE0	18	60	μs
$t_{\text{LPMx0_AMLDO0_NORIO}}^{(2)}$	LPM3_LPM4_VCORE0	AM_LDO_VCORE0	Transition from LPM3 or LPM4 at VCORE0 to AM_LDO_VCORE0 through wake-up event from nonglitch-filter type I/O	8	9	μs
$t_{\text{LPMx0_AMLDO0_GFLTIO}}^{(2)}$	LPM3_LPM4_VCORE0	AM_LDO_VCORE0	Transition from LPM3 or LPM4 at VCORE0 to AM_LDO_VCORE0 through wake-up event from glitch-filter type I/O, GLTFLT_EN = 1	9	10	μs
$t_{\text{AMLDO1_LPMx1}}^{(1)}$	AM_LDO_VCORE1	LPM3_LPM4_VCORE1	Transition from AM_LDO_VCORE1 to LPM3 or LPM4 at VCORE1	17	60	μs
$t_{\text{LPMx1_AMLDO1_NORIO}}^{(2)}$	LPM3_LPM4_VCORE1	AM_LDO_VCORE1	Transition from LPM3 or LPM4 at VCORE1 to AM_LDO_VCORE1 through wake-up event from nonglitch-filter type I/O	7.5	8	μs
$t_{\text{LPMx1_AMLDO1_GFLTIO}}^{(2)}$	LPM3_LPM4_VCORE1	AM_LDO_VCORE1	Transition from LPM3 or LPM4 at VCORE1 to AM_LDO_VCORE1 through wake-up event from glitch-filter type I/O, GLTFLT_EN = 1	8	9	μs
$t_{\text{AMLFx_LPMx_128k}}^{(1)}$	AM_LF_VCOREx	LPM3_LPM4_VCOREx	Transition from AM_LF_VCORE0 or AM_LF_VCORE1 to LPM3 or LPM4 at VCORE0 or VCORE1	255	290	μs
$t_{\text{AMLFx_LPMx_32k}}^{(1)}$	AM_LF_VCOREx	LPM3_LPM4_VCOREx	Transition from AM_LF_VCORE0 or AM_LF_VCORE1 to LPM3 or LPM4 at VCORE0 or VCORE1	980	1025	μs
$t_{\text{LPMx_AMLFx_NORIO_128k}}^{(2)}$	LPM3_LPM4_VCOREx	AM_LF_VCOREx	Transition from LPM3 or LPM4 at VCORE0 or VCORE1 to AM_LF_VCORE0 or AM_LF_VCORE1 through wake-up event from nonglitch-filter type I/O	45	50	μs
$t_{\text{LPMx_AMLFx_NORIO_32k}}^{(2)}$	LPM3_LPM4_VCOREx	AM_LF_VCOREx	Transition from LPM3 or LPM4 at VCORE0 or VCORE1 to AM_LF_VCORE0 or AM_LF_VCORE1 through wake-up event from nonglitch-filter type I/O	150	170	μs

(1) This is the latency from WFI instruction execution by CPU to LPM3 or LPM4 entry.

(2) This is the latency from I/O wake-up event to MCLK clock start at device pin.

Table 5-7 lists the latencies required to change to and from LPM3.5 and LPM4.5 modes.

Table 5-7. LPM3.5, LPM4.5 Mode Transition Latencies

over recommended ranges of supply voltage and operating free-air temperature (unless otherwise noted)

PARAMETER	ORIGINAL OPERATING MODE	FINAL OPERATING MODE	TEST CONDITIONS	TYP	MAX	UNIT
$t_{\text{AMLDOx_LPM3.5}}^{(1)}$	AM_LDO_VCOREx	LPM3.5	Transition from AM_LDO_VCORE0 or AM_LDO_VCORE1 to LPM3.5	57	60	μs
$t_{\text{AMDCCDcx_LPM3.5}}^{(1)}$	AM_DCDC_VCOREx	LPM3.5	Transition from AM_DCDC_VCORE0 or AM_DCDC_VCORE1 to LPM3.5	70	83	μs
$t_{\text{AMLFX_LPM3.5}}^{(1)}$	AM_LF_VCOREx	LPM3.5	Transition from AM_LF_VCORE0 or AM_LF_VCORE1 to LPM3.5	224	275	μs
$t_{\text{AMLDOx_LPM4.5}}^{(2)}$	AM_LDO_VCOREx	LPM4.5	Transition from AM_LDO_VCORE0 or AM_LDO_VCORE1 to LPM4.5	57	60	μs
$t_{\text{AMDCCDcx_LPM4.5}}^{(2)}$	AM_DCDC_VCOREx	LPM4.5	Transition from AM_DCDC_VCORE0 or AM_DCDC_VCORE1 to LPM4.5	68	81	μs
$t_{\text{AMLFX_LPM4.5}}^{(2)}$	AM_LF_VCOREx	LPM4.5	Transition from AM_LF_VCORE0 or AM_LF_VCORE1 to LPM4.5	230	248	μs
$t_{\text{LPM3.5_AMLDO0}}^{(3)}$	LPM3.5	AM_LDO_VCORE0	Transition from LPM3.5 to AM_LDO_VCORE0	0.7	0.8	ms
$t_{\text{LPM4.5_AMLDO0_SVSMON, 100 nF}}^{(3)}$	LPM4.5	AM_LDO_VCORE0	Transition from LPM4.5 to AM_LDO_VCORE0, SVSMH enabled while in LPM4.5, $C_{\text{VCORE}} = 100 \text{ nF}$	0.8	0.9	ms
$t_{\text{LPM4.5_AMLDO0_SVSMON, 4.7 }\mu\text{F}}^{(3)}$	LPM4.5	AM_LDO_VCORE0	Transition from LPM4.5 to AM_LDO_VCORE0, SVSMH enabled while in LPM4.5, $C_{\text{VCORE}} = 4.7 \mu\text{F}$	0.9	1.0	ms
$t_{\text{LPM4.5_AMLDO0_SVSMOFF, 100 nF}}^{(3)}$	LPM4.5	AM_LDO_VCORE0	Transition from LPM4.5 to AM_LDO_VCORE0, SVSMH disabled while in LPM4.5, $C_{\text{VCORE}} = 100 \text{ nF}$	1.0	1.1	ms
$t_{\text{LPM4.5_AMLDO0_SVSMOFF, 4.7 }\mu\text{F}}^{(3)}$	LPM4.5	AM_LDO_VCORE0	Transition from LPM4.5 to AM_LDO_VCORE0, SVSMH disabled while in LPM4.5, $C_{\text{VCORE}} = 4.7 \mu\text{F}$	1.1	1.2	ms

- (1) This is the latency from WFI instruction execution by CPU to LPM3.5 mode entry.
(2) This is the latency from WFI instruction execution by CPU to LPM4.5 mode entry.
(3) This is the latency from I/O wake-up event to start of user application code.

5.26.4 Clock Specifications

Table 5-8 lists the input requirement for the low-frequency crystal oscillator, LFXT.

Table 5-8. Low-Frequency Crystal Oscillator, LFXT, Recommended Operating Conditions

over operating free-air temperature range (unless otherwise noted)

PARAMETER		TEST CONDITIONS	MIN	TYP	MAX	UNIT
ESR	Crystal equivalent series resistance	$f_{OSC} = 32.768 \text{ kHz}$	16	40	65	k Ω
C_{LFXT}	Capacitance from LFXT input to ground and from LFXT output to ground ⁽¹⁾		7.4	12	24	pF
C_{SHUNT}	Crystal shunt capacitance		0.6	0.8	1.6	pF
C_m	Crystal motional capacitance		1	2	10	fF

(1) Does not include board parasitics. Package and board add additional capacitance to C_{LFXT} .

Table 5-9 lists the characteristics of the low-frequency crystal oscillator, LFXT.

Table 5-9. Low-Frequency Crystal Oscillator, LFXT

over recommended ranges of supply voltage and operating free-air temperature (unless otherwise noted)

PARAMETER		TEST CONDITIONS	V_{CC}	MIN	TYP	MAX	UNIT
$I_{VCC,LFXT}$	Current consumption ⁽¹⁾	$f_{OSC} = 32.768 \text{ kHz}$, LFXTBYPASS = 0, LFXTDRIVE = {0}, $C_{L,eff} = 3.7 \text{ pF}$, Typical ESR, C_{SHUNT}	3.0 V	100		nA	
		$f_{OSC} = 32.768 \text{ kHz}$, LFXTBYPASS = 0, LFXTDRIVE = {1}, $C_{L,eff} = 6 \text{ pF}$, Typical ESR, C_{SHUNT}		120			
		$f_{OSC} = 32.768 \text{ kHz}$, LFXTBYPASS = 0, LFXTDRIVE = {2}, $C_{L,eff} = 9 \text{ pF}$, Typical ESR, C_{SHUNT}		150			
		$f_{OSC} = 32.768 \text{ kHz}$, LFXTBYPASS = 0, LFXTDRIVE = {3}, $C_{L,eff} = 12 \text{ pF}$, Typical ESR, C_{SHUNT}		170			
f_{LFXT}	LFXT oscillator crystal frequency	LFXTBYPASS = 0 ⁽²⁾		32.768		kHz	
DC_{LFXT}	LFXT oscillator duty cycle	$f_{LFXT} = 32.768 \text{ kHz}$ ⁽²⁾		30%		70%	
$f_{LFXT,SW}$	LFXT oscillator logic-level square-wave input frequency	LFXTBYPASS = 1 ^{(3) (4)}		10	32.768	50	kHz
$DC_{LFXT,SW}$	LFXT oscillator logic-level square-wave input duty cycle	LFXTBYPASS = 1		30%		70%	
OA_{LFXT}	Oscillation allowance for LF crystals ⁽⁵⁾	LFXTBYPASS = 0, LFXTDRIVE = {1}, $f_{LFXT} = 32.768 \text{ kHz}$, $C_{L,eff} = 6 \text{ pF}$		200	240	k Ω	
		LFXTBYPASS = 0, LFXTDRIVE = {3}, $f_{LFXT} = 32.768 \text{ kHz}$, $C_{L,eff} = 12 \text{ pF}$		300	340		

(1) Total current measured on both AVCC and DVCC supplies.

(2) Measured at ACLK pin.

(3) When LFXTBYPASS is set, LFXT circuits are automatically powered down. Input signal is a digital square wave with parametrics defined in the Schmitt-trigger Inputs section of this data sheet. Duty cycle requirements are defined by $DC_{LFXT, SW}$.

(4) Maximum frequency of operation of the entire device cannot be exceeded.

(5) Oscillation allowance is based on a safety factor of 5 for recommended crystals. The oscillation allowance is a function of the LFXTDRIVE settings and the effective load. In general, comparable oscillator allowance can be achieved based on the following guidelines, but should be evaluated based on the actual crystal selected for the application:

- For LFXTDRIVE = {0}, $C_{L,eff} = 3.7 \text{ pF}$
- For LFXTDRIVE = {1}, $6 \text{ pF} \leq C_{L,eff} \leq 9 \text{ pF}$
- For LFXTDRIVE = {2}, $6 \text{ pF} \leq C_{L,eff} \leq 10 \text{ pF}$
- For LFXTDRIVE = {3}, $6 \text{ pF} \leq C_{L,eff} \leq 12 \text{ pF}$

Table 5-9. Low-Frequency Crystal Oscillator, LFXT (continued)

over recommended ranges of supply voltage and operating free-air temperature (unless otherwise noted)

PARAMETER		TEST CONDITIONS	V _{CC}	MIN	TYP	MAX	UNIT
C _{LFXIN}	Integrated load capacitance at LFXIN terminal ^{(6) (7)}				2		pF
C _{LFXOUT}	Integrated load capacitance at LFXOUT terminal ^{(6) (7)}				2		pF
t _{START,LFXT}	Start-up time ⁽⁸⁾	f _{OSC} = 32.768 kHz, LFXTBYPASS = 0, LFXTDRIVE = {0}, C _{L,eff} = 3.7 pF, Typical ESR, C _{SHUNT} , FCNTLF_EN = 0 ⁽²⁾	3.0 V		1.1		s
		f _{OSC} = 32.768 kHz, LFXTBYPASS = 0, LFXTDRIVE = {3}, C _{L,eff} = 12 pF, Typical ESR, C _{SHUNT} , FCNTLF_EN = 0 ⁽²⁾			1.3		
f _{FAULT,LFXT}	Oscillator fault frequency ^{(9) (10)}			1		3	kHz

- (6) This represents all the parasitic capacitance present at the LFXIN and LFXOUT terminals, respectively, including parasitic bond and package capacitance. The effective load capacitance, C_{L,eff} can be computed as C_{IN} × C_{OUT} / (C_{IN} + C_{OUT}), where C_{IN} and C_{OUT} are the total capacitance at the LFXIN and LFXOUT terminals, respectively.
- (7) Requires external capacitors at both terminals to meet the effective load capacitance specified by crystal manufacturers. Recommended effective load capacitance values supported are 3.7 pF, 6 pF, 9 pF, and 12 pF. Maximum shunt capacitance of 1.6 pF. Because the PCB adds additional capacitance, it must also be considered in the overall capacitance. Verify that the recommended effective load capacitance of the selected crystal is met.
- (8) Does not include programmable start-up counter.
- (9) Frequencies greater than the MAX specification do not set the fault flag. Frequencies between the MIN and MAX specification may set the flag. A static condition or stuck-at-fault condition sets the fault flag.
- (10) Measured with logic-level input frequency but also applies to operation with crystals.

Table 5-10 lists the input requirements for the high-frequency crystal oscillator, HFXT.

Table 5-10. High-Frequency Crystal Oscillator, HFXT, Recommended Operating Conditions

over operating free-air temperature range (unless otherwise noted)

PARAMETER		TEST CONDITIONS	MIN	TYP	MAX	UNIT
ESR	Crystal equivalent series resistance	f _{OSC} = 1 MHz to ≤ 4 MHz		75	150	Ω
		f _{OSC} = > 4 MHz to ≤ 8 MHz		75	150	
		f _{OSC} = > 8 MHz to ≤ 16 MHz		40	80	
		f _{OSC} = > 16 MHz to ≤ 24 MHz		30	60	
		f _{OSC} = > 24 MHz to ≤ 32 MHz		20	40	
		f _{OSC} = > 32 MHz to ≤ 48 MHz		15	30	
C _{HFXT}	Capacitance from HFXT input to ground and from HFXT output to ground	f _{OSC} = 1 MHz to 48 MHz	28	32	36	pF
C _{SHUNT}	Crystal shunt capacitance	f _{OSC} = 1 MHz to 48 MHz	1	3	7	pF
C _m	Crystal motional capacitance	f _{OSC} = 1 MHz to 48 MHz	3	7	30	fF

Table 5-11 lists the characteristics of the high-frequency crystal oscillator, HFXT.

Table 5-11. High-Frequency Crystal Oscillator, HFXT

over recommended ranges of supply voltage and operating free-air temperature (unless otherwise noted)

PARAMETER		TEST CONDITIONS	V _{CC}	MIN	TYP	MAX	UNIT
I _{DVCC,HFXT}	HFXT oscillator crystal current HF mode at typical ESR	f _{OSC} = 1 MHz, HFXTBYPASS = 0, HFXTDRIVE = 0, HFFREQ = 0, C _{L,eff} = 16 pF, Typical ESR and C _{SHUNT}	3.0 V		40		μA
		f _{OSC} = 4 MHz, HFXTBYPASS = 0, HFXTDRIVE = 1, HFFREQ = 0, C _{L,eff} = 16 pF, Typical ESR and C _{SHUNT}			60		
		f _{OSC} = 8 MHz, HFXTBYPASS = 0, HFXTDRIVE = 1, HFFREQ = 1, C _{L,eff} = 16 pF, Typical ESR and C _{SHUNT}			100		
		f _{OSC} = 16 MHz, HFXTBYPASS = 0, HFXTDRIVE = 1, HFFREQ = 2, C _{L,eff} = 16 pF, Typical ESR and C _{SHUNT}			180		
		f _{OSC} = 24 MHz, HFXTBYPASS = 0, HFXTDRIVE = 1, HFFREQ = 3, C _{L,eff} = 16 pF, Typical ESR and C _{SHUNT}			260		
		f _{OSC} = 32 MHz, HFXTBYPASS = 0, HFXTDRIVE = 1, HFFREQ = 4, C _{L,eff} = 16 pF, Typical ESR and C _{SHUNT}			320		
		f _{OSC} = 40 MHz, HFXTBYPASS = 0, HFXTDRIVE = 1, HFFREQ = 5, C _{L,eff} = 16 pF, Typical ESR and C _{SHUNT}			480		
		f _{OSC} = 48 MHz, HFXTBYPASS = 0, HFXTDRIVE = 1, HFFREQ = 6, C _{L,eff} = 16 pF, Typical ESR and C _{SHUNT}			550		
f _{HFXT}	HFXT oscillator crystal frequency, crystal mode	HFXTBYPASS = 0, HFFREQ = 0 ⁽¹⁾		1		4	MHz
		HFXTBYPASS = 0, HFFREQ = 1 ⁽¹⁾		4.01		8	
		HFXTBYPASS = 0, HFFREQ = 2 ⁽¹⁾		8.01		16	
		HFXTBYPASS = 0, HFFREQ = 3 ⁽¹⁾		16.01		24	
		HFXTBYPASS = 0, HFFREQ = 4 ⁽¹⁾		24.01		32	
		HFXTBYPASS = 0, HFFREQ = 5 ⁽¹⁾		32.01		40	
		HFXTBYPASS = 0, HFFREQ = 6 ⁽¹⁾		40.01		48	
DC _{HFXT}	HFXT oscillator duty cycle	Measured at MCLK or HSMCLK, f _{HFXT} = 1 MHz to 48 MHz		40%	50%	60%	
f _{HFXT,SW}	HFXT oscillator logic-level square-wave input frequency, bypass mode	HFXTBYPASS = 1 ⁽¹⁾⁽²⁾		0.8		48	MHz
DC _{HFXT, SW}	HFXT oscillator logic-level square-wave input duty cycle	HFXTBYPASS = 1, External clock used as a direct source to MCLK or HSMCLK with no divider (DIVM = 0 or DIVHS = 0).		45%		55%	
		HFXTBYPASS = 1, External clock used as a direct source to MCLK or HSMCLK with divider (DIVM > 0 or DIVHS > 0) or not used as a direct source to MCLK or HSMCLK.		40%		60%	

(1) Maximum frequency of operation of the entire device cannot be exceeded.

(2) When HFXTBYPASS is set, HFXT circuits are automatically powered down. Input signal is a digital square wave with parametrics defined in the Schmitt-trigger Inputs section of this data sheet. Duty cycle requirements are defined by DC_{HFXT, SW}.

Table 5-11. High-Frequency Crystal Oscillator, HFXT (continued)

over recommended ranges of supply voltage and operating free-air temperature (unless otherwise noted)

PARAMETER		TEST CONDITIONS	V _{CC}	MIN	TYP	MAX	UNIT
O _{AHFXT}	Oscillation allowance for HFXT crystals ⁽³⁾	HFXTBYPASS = 0, HFXTDRIVE = 0, HFFREQ = 0, f _{HFXT,HF} = 1 MHz, C _{L,eff} = 16 pF		1225	5000		Ω
		HFXTBYPASS = 0, HFXTDRIVE = 1, HFFREQ = 0, f _{HFXT,HF} = 4 MHz, C _{L,eff} = 16 pF		640	1250		
		HFXTBYPASS = 0, HFXTDRIVE = 1, HFFREQ = 1, f _{HFXT,HF} = 8 MHz, C _{L,eff} = 16 pF		360	750		
		HFXTBYPASS = 0, HFXTDRIVE = 1, HFFREQ = 2, f _{HFXT,HF} = 16 MHz, C _{L,eff} = 16 pF		200	425		
		HFXTBYPASS = 0, HFXTDRIVE = 1, HFFREQ = 3, f _{HFXT,HF} = 24 MHz, C _{L,eff} = 16 pF		135	275		
		HFXTBYPASS = 0, HFXTDRIVE = 1, HFFREQ = 4, f _{HFXT,HF} = 32 MHz, C _{L,eff} = 16 pF		110	225		
		HFXTBYPASS = 0, HFXTDRIVE = 1, HFFREQ = 5, f _{HFXT,HF} = 40 MHz, C _{L,eff} = 16 pF		105	160		
		HFXTBYPASS = 0, HFXTDRIVE = 1, HFFREQ = 6, f _{HFXT,HF} = 48 MHz, C _{L,eff} = 16 pF		80	140		

(3) Oscillation allowance is based on a safety factor of 5 for recommended crystals.

Table 5-11. High-Frequency Crystal Oscillator, HFXT (continued)

over recommended ranges of supply voltage and operating free-air temperature (unless otherwise noted)

PARAMETER		TEST CONDITIONS	V _{CC}	MIN	TYP	MAX	UNIT
t _{START,HFXT}	Start-up time ⁽⁴⁾	f _{OSC} = 1 MHz, HFXTBYPASS = 0, HFXTDRIVE = 0, HFFREQ = 0, C _{L,eff} = 16 pF, Typical ESR and C _{SHUNT} , FCNTHF_EN = 0	3.0 V		4		ms
		f _{OSC} = 4 MHz, HFXTBYPASS = 0, HFXTDRIVE = 1, HFFREQ = 0, C _{L,eff} = 16 pF, Typical ESR and C _{SHUNT} , FCNTHF_EN = 0			1.8		
		f _{OSC} = 8 MHz, HFXTBYPASS = 0, HFXTDRIVE = 1, HFFREQ = 1, C _{L,eff} = 16 pF, Typical ESR and C _{SHUNT} , FCNTHF_EN = 0			0.7		
		f _{OSC} = 16 MHz, HFXTBYPASS = 0, HFXTDRIVE = 1, HFFREQ = 2, C _{L,eff} = 16 pF, Typical ESR and C _{SHUNT} , FCNTHF_EN = 0			0.6		
		f _{OSC} = 24 MHz, HFXTBYPASS = 0, HFXTDRIVE = 1, HFFREQ = 3, C _{L,eff} = 16 pF, Typical ESR and C _{SHUNT} , FCNTHF_EN = 0			450		μs
		f _{OSC} = 32 MHz, HFXTBYPASS = 0, HFXTDRIVE = 1, HFFREQ = 4, C _{L,eff} = 16 pF, Typical ESR and C _{SHUNT} , FCNTHF_EN = 0			300		
		f _{OSC} = 40 MHz, HFXTBYPASS = 0, HFXTDRIVE = 1, HFFREQ = 5, C _{L,eff} = 16 pF, Typical ESR and C _{SHUNT} , FCNTHF_EN = 0			250		
		f _{OSC} = 48 MHz, HFXTBYPASS = 0, HFXTDRIVE = 1, HFFREQ = 6, C _{L,eff} = 16 pF, Typical ESR and C _{SHUNT} , FCNTHF_EN = 0			250		
C _{HFXIN}	Integrated load capacitance at HFXIN terminal ^{(5) (6)}			2		pF	
C _{HFXOUT}	Integrated load capacitance at HFXOUT terminal ^{(5) (6)}			2		pF	
f _{Fault,HFXT}	Oscillator fault frequency ^{(7) (8)}			400		700	kHz

- (4) Does not include programmable start-up counter.
- (5) This represents all the parasitic capacitance present at the HFXIN and HFXOUT terminals, respectively, including parasitic bond and package capacitance. The effective load capacitance, C_{L,eff} can be computed as C_{IN} × C_{OUT} / (C_{IN} + C_{OUT}), where C_{IN} and C_{OUT} are the total capacitance at the HFXIN and HFXOUT terminals, respectively.
- (6) Requires external capacitors at both terminals to meet the effective load capacitance specified by crystal manufacturers. Recommended effective load capacitance values supported are 14 pF, 16 pF, and 18 pF. Maximum shunt capacitance of 7 pF. The PCB adds additional capacitance, so it must also be considered in the overall capacitance. Verify that the recommended effective load capacitance of the selected crystal is met.
- (7) Frequencies greater than the MAX specification do not set the fault flag. Frequencies between the MIN and MAX specification may set the flag. A static condition or stuck-at-fault condition sets the fault flag.
- (8) Measured with logic-level input frequency but also applies to operation with crystals.

Table 5-12 lists the characteristics of the DCO.

Table 5-12. DCO

over recommended ranges of supply voltage and operating free-air temperature (unless otherwise noted)

PARAMETER		TEST CONDITIONS	V _{CC} , T _A	MIN	TYP	MAX	UNIT
f _{RSEL0_CTR}	DCO center frequency accuracy for range 0 with calibrated factory settings	Internal resistor mode, DCORSEL = 0, DCOTUNE = 0		1.443	1.5	1.557	MHz
		External resistor mode, DCORSEL = 0, DCOTUNE = 0		1.482	1.5	1.518	
f _{RSEL1_CTR}	DCO center frequency accuracy for range 1 with calibrated factory settings	Internal resistor mode, DCORSEL = 1, DCOTUNE = 0		2.885	3	3.115	MHz
		External resistor mode, DCORSEL = 1, DCOTUNE = 0		2.964	3	3.036	
f _{RSEL2_CTR}	DCO center frequency accuracy for range 2 with calibrated factory settings	Internal resistor mode, DCORSEL = 2, DCOTUNE = 0		5.77	6	6.23	MHz
		External resistor mode, DCORSEL = 2, DCOTUNE = 0		5.928	6	6.072	
f _{RSEL3_CTR}	DCO center frequency accuracy for range 3 with calibrated factory settings	Internal resistor mode, DCORSEL = 3, DCOTUNE = 0		11.541	12	12.459	MHz
		External resistor mode, DCORSEL = 3, DCOTUNE = 0		11.856	12	12.144	
f _{RSEL4_CTR}	DCO center frequency accuracy for range 4 with calibrated factory settings	Internal resistor mode, DCORSEL = 4, DCOTUNE = 0		23.082	24	24.918	MHz
		External resistor mode, DCORSEL = 4, DCOTUNE = 0		23.712	24	24.288	
f _{RSEL5_CTR}	DCO center frequency accuracy for range 5 with calibrated factory settings	Internal resistor mode, DCORSEL = 5, DCOTUNE = 0		46.164	48	49.836	MHz
		External resistor mode, DCORSEL = 5, DCOTUNE = 0		47.424	48	48.576	
df _{DCO} /dT	DCO frequency drift with temperature ⁽¹⁾	Internal resistor mode, At fixed voltage	1.62 V to 3.7 V			250	ppm/°C
		External resistor mode ⁽²⁾ At fixed voltage	1.62 V to 3.7 V			60	
df _{DCO} /dV _{CC}	DCO frequency voltage drift with voltage ⁽³⁾	At fixed temperature, applicable for both DCO Internal and External resistor modes	–40°C to 85 °C			0.1	%/V
f _{RSEL0}	DCO frequency range 0	DCORSEL = 0 DCO internal or external resistor mode	3.0 V, 25°C	0.98		2.26	MHz
f _{RSEL1}	DCO frequency range 1	DCORSEL = 1 DCO internal or external resistor mode	3.0 V, 25°C	1.96		4.51	MHz
f _{RSEL2}	DCO frequency range 2	DCORSEL = 2 DCO internal or external resistor mode	3.0 V, 25°C	3.92		9.02	MHz
f _{RSEL3}	DCO frequency range 3	DCORSEL = 3 DCO internal or external resistor mode	3.0 V, 25°C	7.84		18.04	MHz
f _{RSEL4}	DCO frequency range 4	DCORSEL = 4 DCO internal or external resistor mode	3.0 V, 25°C	15.68		36.07	MHz
f _{RSEL5}	DCO frequency range 5	DCORSEL = 5 DCO internal or external resistor mode	3.0 V, 25°C	31.36		52	MHz
f _{DCO_DC}	Duty cycle			47%	50%	53%	

(1) Calculated using the box method: (MAX(–40°C to 85°C) – MIN(–40°C to 85°C)) / MIN(–40°C to 85°C) / (85°C – (–40°C))

(2) Does not include temperature coefficient of external resistor.

The recommended value of external resistor at DCOR pin: 91 kΩ, 0.1%, ±25 ppm/°C.

(3) Calculated using the box method: (MAX(1.62 V to 3.7 V) – MIN(1.62 V to 3.7 V)) / MIN(1.62 V to 3.7 V) / (3.7 V – 1.62 V)

Table 5-12. DCO (continued)

over recommended ranges of supply voltage and operating free-air temperature (unless otherwise noted)

PARAMETER		TEST CONDITIONS	V _{CC} , T _A	MIN	TYP	MAX	UNIT
t _{DCO_JITTER}	DCO period jitter	DCORSEL = 5, DCOTUNE = 0		50	90	ps	
		DCORSEL = 4, DCOTUNE = 0		80	120		
		DCORSEL = 3, DCOTUNE = 0		115	170		
		DCORSEL = 2, DCOTUNE = 0		160	240		
		DCORSEL = 1, DCOTUNE = 0		225	340		
		DCORSEL = 0, DCOTUNE = 0		450	550		
T _{DCO_STEP}	Step size	Step size of the DCO		0.2%			
t _{DCO_SETTLE_RANGE}	DCO settling from worst case DCORSEL _n to DCORSEL _m	DCO settled to within 1.5% of steady state frequency				10	μs
t _{DCO_SETTLE_TUNE}	DCO settling worst case DCOTUNE _n to DCOTUNE _m within any DCORSEL setting	DCO settled to within 1.5% of steady state frequency				10	μs
t _{START}	DCO start-up time ⁽⁴⁾	DCO settled to within 0.5% of steady state frequency		5			μs

(4) The maximum parasitic capacitance at the DCO external resistance pin (DCOR) should not exceed 5 pF to ensure the specified DCO start-up time.

Table 5-13 lists the overall tolerance of the DCO.

Table 5-13. DCO Overall Tolerance

over operating free-air temperature range (unless otherwise noted)

RESISTOR OPTION	TEMPERATURE CHANGE	TEMPERATURE DRIFT (%)	VOLTAGE CHANGE	VOLTAGE DRIFT (%)	OVERALL DRIFT (%)	OVERALL ACCURACY (%)
Internal resistor	–40°C to 85 °C	±3.125	1.62 V to 3.7 V	±0.2	±3.325	±3.825
	0°C	0	1.62 V to 3.7 V	±0.2	±0.2	±0.7
	–40°C to 85 °C	±3.125	0 V	0	±3.125	±3.625
External resistor with 25-ppm TCR	–40°C to 85 °C	±0.5	1.62 V to 3.7 V	±0.2	±0.7	±1.2
	0°C	0	1.62 V to 3.7 V	±0.2	±0.2	±0.7
	–40°C to 85 °C	±0.5	0 V	0	±0.5	±1

Table 5-14 lists the characteristics of the internal very-low-power low-frequency oscillator (VLO).

Table 5-14. Internal Very-Low-Power Low-Frequency Oscillator (VLO)

over recommended ranges of supply voltage and operating free-air temperature (unless otherwise noted)

PARAMETER		TEST CONDITIONS	MIN	TYP	MAX	UNIT
I_{VLO}	Current consumption ⁽¹⁾			50		nA
f_{VLO}	VLO frequency		6	9.4	18	kHz
df_{VLO}/dT	VLO frequency temperature drift ⁽²⁾			0.1		%/°C
df_{VLO}/dV_{CC}	VLO frequency supply voltage drift ⁽³⁾			0.2		%/V
DC_{VLO}	Duty cycle		40%	50%	60%	

(1) Current measured on DVCC supply

(2) Calculated using the box method: $(MAX(-40^{\circ}C \text{ to } 85^{\circ}C) - MIN(-40^{\circ}C \text{ to } 85^{\circ}C)) / MIN(-40^{\circ}C \text{ to } 85^{\circ}C) / (85^{\circ}C - (-40^{\circ}C))$

(3) Calculated using the box method: $(MAX(1.62 \text{ V to } 3.7 \text{ V}) - MIN(1.62 \text{ V to } 3.7 \text{ V})) / MIN(1.62 \text{ V to } 3.7 \text{ V}) / (3.7 \text{ V} - 1.62 \text{ V})$

Table 5-15 lists the characteristics of the internal-reference low-frequency oscillator (REFO) in 32.768-kHz mode.

Table 5-15. Internal-Reference Low-Frequency Oscillator (REFO) – 32.768-kHz Mode⁽¹⁾

over recommended ranges of supply voltage and operating free-air temperature (unless otherwise noted)

PARAMETER		TEST CONDITIONS	V_{CC}	MIN	TYP	MAX	UNIT
I_{REFO}	REFO current consumption ⁽²⁾				0.6		μ A
f_{REFO}	REFO frequency calibrated				32.768		kHz
	REFO absolute tolerance calibrated	$T_A = -40^{\circ}C \text{ to } 85^{\circ}C$				$\pm 4\%$	
		$T_A = 25^{\circ}C$	3 V			$\pm 1.5\%$	
df_{REFO}/dT	REFO frequency temperature drift ⁽³⁾				0.012		%/°C
df_{REFO}/dV_{CC}	REFO frequency supply voltage drift ⁽⁴⁾				0.2		%/V
DC_{REFO}	REFO duty cycle			40%	50%	60%	

(1) REFO is configured to 32.768-kHz mode with REFOFSEL = 0.

(2) Total current measured on both AVCC and DVCC supplies.

(3) Calculated using the box method: $(MAX(-40^{\circ}C \text{ to } 85^{\circ}C) - MIN(-40^{\circ}C \text{ to } 85^{\circ}C)) / MIN(-40^{\circ}C \text{ to } 85^{\circ}C) / (85^{\circ}C - (-40^{\circ}C))$

(4) Calculated using the box method: $(MAX(1.62 \text{ V to } 3.7 \text{ V}) - MIN(1.62 \text{ V to } 3.7 \text{ V})) / MIN(1.62 \text{ V to } 3.7 \text{ V}) / (3.7 \text{ V} - 1.62 \text{ V})$

Table 5-16 lists the characteristics of the internal-reference low-frequency oscillator (REFO) in 128-kHz mode.

Table 5-16. Internal-Reference Low-Frequency Oscillator (REFO) – 128-kHz Mode⁽¹⁾

over recommended ranges of supply voltage and operating free-air temperature (unless otherwise noted)

PARAMETER		TEST CONDITIONS	V_{CC}	MIN	TYP	MAX	UNIT
REFO	REFO current consumption ⁽²⁾				1		μ A
f_{REFO}	REFO frequency calibrated				128		kHz
	REFO absolute tolerance calibrated	$T_A = -40^{\circ}C \text{ to } 85^{\circ}C$				$\pm 6\%$	
		$T_A = 25^{\circ}C$	3 V			$\pm 1.5\%$	
df_{REFO}/dT	REFO frequency temperature drift ⁽³⁾				0.018		%/°C
df_{REFO}/dV_{CC}	REFO frequency supply voltage drift ⁽⁴⁾				0.4		%/V
DC_{REFO}	REFO duty cycle			40%	50%	60%	

(1) REFO is configured to 128-kHz mode with REFOFSEL = 1.

(2) Total current measured on both AVCC and DVCC supplies.

(3) Calculated using the box method: $(MAX(-40^{\circ}C \text{ to } 85^{\circ}C) - MIN(-40^{\circ}C \text{ to } 85^{\circ}C)) / MIN(-40^{\circ}C \text{ to } 85^{\circ}C) / (85^{\circ}C - (-40^{\circ}C))$

(4) Calculated using the box method: $(MAX(1.62 \text{ V to } 3.7 \text{ V}) - MIN(1.62 \text{ V to } 3.7 \text{ V})) / MIN(1.62 \text{ V to } 3.7 \text{ V}) / (3.7 \text{ V} - 1.62 \text{ V})$

Table 5-17 lists the characteristics of the module oscillator (MODOSC).

Table 5-17. Module Oscillator (MODOSC)

over recommended ranges of supply voltage and operating free-air temperature (unless otherwise noted)

PARAMETER		TEST CONDITIONS	V _{CC}	MIN	TYP	MAX	UNIT
I _{MODOSC}	Current consumption ⁽¹⁾				50		μA
f _{MODOSC}	MODOSC frequency			23	25	27	MHz
df _{MODOSC} /dT	MODOSC frequency temperature drift ⁽²⁾				0.02		%/°C
df _{MODOSC} /dV _{CC}	MODOSC frequency supply voltage drift ⁽³⁾				0.3		%/V
DC _{MODOSC}	Duty cycle			40%	50%	60%	

(1) Total current measured on both AVCC and DVCC supplies.

(2) Calculated using the box method: (MAX(−40°C to 85°C) – MIN(−40°C to 85°C)) / MIN(−40°C to 85°C) / (85°C – (−40°C))

(3) Calculated using the box method: (MAX(1.62 V to 3.7 V) – MIN(1.62 V to 3.7 V)) / MIN(1.62 V to 3.7 V) / (3.7 V – 1.62 V)

Table 5-18 lists the characteristics of the system oscillator (SYSOSC).

Table 5-18. System Oscillator (SYSOSC)

over recommended ranges of supply voltage and operating free-air temperature (unless otherwise noted)

PARAMETER		TEST CONDITIONS	V _{CC}	MIN	TYP	MAX	UNIT
I _{SYSOSC}	Current consumption ⁽¹⁾				30		μA
f _{SYSOSC}	SYSOSC frequency			4.25	5.0	5.75	MHz
df _{SYSOSC} /dT	SYSOSC frequency temperature drift ⁽²⁾				0.03		%/°C
df _{SYSOSC} /dV _{CC}	SYSOSC frequency supply voltage drift ⁽³⁾				0.5		%/V
DC _{SYSOSC}	Duty cycle			40%	50%	60%	

(1) Current measured on AVCC supply.

(2) Calculated using the box method: (MAX(−40°C to 85°C) – MIN(−40°C to 85°C)) / MIN(−40°C to 85°C) / (85°C – (−40°C))

(3) Calculated using the box method: (MAX(1.62 V to 3.7 V) – MIN(1.62 V to 3.7 V)) / MIN(1.62 V to 3.7 V) / (3.7 V – 1.62 V)

5.26.5 Power Supply System

Table 5-19 lists the LDO V_{CORE} regulator characteristics.

Table 5-19. V_{CORE} Regulator (LDO) Characteristics

PARAMETER	TEST CONDITIONS	MIN	TYP	MAX	UNIT	
$V_{CORE0-HP}$	Static V_{CORE} voltage level 0 in active and LPM0 modes	Device power modes AM_LDO_VCORE0, LPM0_LDO_VCORE0	1.12	1.2	1.28	V
$V_{CORE1-HP}$	Static V_{CORE} voltage level 1 in active and LPM0 modes	Device power modes AM_LDO_VCORE1, LPM0_LDO_VCORE1	1.31	1.4	1.49	V
$V_{CORE0-LF}$	Static V_{CORE} voltage level 0 in low-frequency active and low-frequency LPM0 modes	Device power modes AM_LF_VCORE0	1.12	1.2	1.28	V
$V_{CORE1-LF}$	Static V_{CORE} voltage level 1 in low-frequency active and low-frequency LPM0 modes	Device power modes AM_LF_VCORE1	1.31	1.4	1.49	V
$V_{CORE0-LPM34}$	Static V_{CORE} voltage level 0 in LPM3 and LPM4 modes	Device power modes LPM3, LPM4	1.08	1.2	1.32	V
$V_{CORE1-LPM34}$	Static V_{CORE} voltage level 1 in LPM3 and LPM4 modes	Device power modes LPM3, LPM4	1.27	1.4	1.53	V
$V_{CORE0-LPM35}$	Static V_{CORE} voltage level 0 in LPM3.5 mode	Device power mode LPM3.5	1.08	1.2	1.32	V
$I_{INRUSH-ST}$	Inrush current at start-up	Device power up			200	mA
$I_{PEAK-LDO}$	Peak current drawn by LDO from DV_{CC}				350	mA
$I_{SC-coreLDO}$	Short-circuit current limit for core LDO	Measured when output is shorted to ground			300	mA

Table 5-20 lists the DC/DC V_{CORE} regulator characteristics.

Table 5-20. V_{CORE} Regulator (DC/DC) Characteristics

PARAMETER	TEST CONDITIONS	MIN	TYP	MAX	UNIT	
$DV_{CC-DCDC}$	Allowed DV_{CC} range for DC/DC operation	DCDC_FORCE = 1	1.8	3.7	V	
$V_{DCDC_SO}^{(1)}$	DC/DC to LDO switch over voltage	$dDV_{CC}/dt = 1 \text{ V/ms}$, DCDC_FORCE = 0	1.8	2.0	V	
$V_{CORE0-DCDC}$	Static V_{CORE} voltage level 0 in DC/DC high-performance modes	Device power modes AM_DCDC_VCORE0, LPM0_DCDC_VCORE0	1.12	1.2	1.28	V
$V_{CORE1-DCDC}$	Static V_{CORE} voltage level 1 in DC/DC high-performance modes	Device power modes AM_DCDC_VCORE1, LPM0_DCDC_VCORE1	1.31	1.4	1.49	V
$I_{PEAK-DCDC}$	Peak current drawn by DC/DC from DV_{CC}				300	mA
$I_{SC-DCDC}$	Short-circuit current limit for DC/DC	Measured when output is shorted to ground			500	mA

(1) When DV_{CC} falls below this voltage, the regulator automatically switches from DC/DC to LDO.

Table 5-21 lists the VCCDET characteristics.

Table 5-21. PSS, VCCDET

over recommended ranges of supply voltage and operating free-air temperature (unless otherwise noted)

PARAMETER		TEST CONDITIONS	MIN	TYP	MAX	UNIT
V _{VCC_VCCDET-}	VCCDET power-down level - trip point with falling V _{CC}	dDV _{CC} /dt < 3 V/s ⁽¹⁾	0.64	1.12	1.55	V
V _{VCC_VCCDET+}	VCCDET power-up level - trip point with rising V _{CC}	dDV _{CC} /dt < 3 V/s ⁽¹⁾	0.70	1.18	1.59	V
V _{VCC_VCC_hys}	VCCDET hysteresis		30	65	100	mV

(1) The VCCDET levels are measured with a slow-changing supply. Faster slopes can result in different levels.

Table 5-22 lists the SVSMH characteristics.

Table 5-22. PSS, SVSMH

over recommended ranges of supply voltage and operating free-air temperature (unless otherwise noted)

PARAMETER		TEST CONDITIONS	MIN	TYP	MAX	UNIT
I _{SVSMH}	SVSM _H current consumption, low-power mode	SVSMHOFF = 0, SVSMHLP = 1		200	400	nA
	SVSM _H current consumption, high-performance mode	SVSMHOFF = 0, SVSMHLP = 0		7	10	μA
V _{SVSMH-,HP}	SVSM _H threshold level during high-performance mode (falling DV _{CC})	SVSMHOFF = 0, SVSMHLP = 0, SVSMHTH = 0, DC (dDV _{CC} /dt < 1 V/s)	1.59	1.64	1.71	V
		SVSMHOFF = 0, SVSMHLP = 0, SVSMHTH = 1, DC (dDV _{CC} /dt < 1 V/s)	1.59	1.64	1.71	
		SVSMHOFF = 0, SVSMHLP = 0, SVSMHTH = 2, DC (dDV _{CC} /dt < 1 V/s)	1.59	1.64	1.71	
		SVSMHOFF = 0, SVSMHLP = 0, SVSMHTH = 3, DC (dDV _{CC} /dt < 1 V/s)	2.0	2.06	2.12	
		SVSMHOFF = 0, SVSMHLP = 0, SVSMHTH = 4, DC (dDV _{CC} /dt < 1 V/s)	2.2	2.26	2.32	
		SVSMHOFF = 0, SVSMHLP = 0, SVSMHTH = 5, DC (dDV _{CC} /dt < 1 V/s)	2.4	2.47	2.54	
		SVSMHOFF = 0, SVSMHLP = 0, SVSMHTH = 6, DC (dDV _{CC} /dt < 1 V/s)	2.7	2.79	2.88	
		SVSMHOFF = 0, SVSMHLP = 0, SVSMHTH = 7, DC (dDV _{CC} /dt < 1 V/s)	2.9	3.0	3.1	
V _{SVSMH+,HP}	SVSM _H threshold level, high-performance mode (rising DV _{CC})	SVSMHOFF = 0, SVSMHLP = 0, SVSMHTH = 0, DC (dDV _{CC} /dt < 1 V/s)	1.6	1.66	1.71	V
		SVSMHOFF = 0, SVSMHLP = 0, SVSMHTH = 1, DC (dDV _{CC} /dt < 1 V/s)	1.6	1.66	1.71	
		SVSMHOFF = 0, SVSMHLP = 0, SVSMHTH = 2, DC (dDV _{CC} /dt < 1 V/s)	1.6	1.66	1.71	
		SVSMHOFF = 0, SVSMHLP = 0, SVSMHTH = 3, DC (dDV _{CC} /dt < 1 V/s)	2.02	2.07	2.14	
		SVSMHOFF = 0, SVSMHLP = 0, SVSMHTH = 4, DC (dDV _{CC} /dt < 1 V/s)	2.22	2.27	2.34	
		SVSMHOFF = 0, SVSMHLP = 0, SVSMHTH = 5, DC (dDV _{CC} /dt < 1 V/s)	2.42	2.48	2.56	
		SVSMHOFF = 0, SVSMHLP = 0, SVSMHTH = 6, DC (dDV _{CC} /dt < 1 V/s)	2.72	2.8	2.9	
		SVSMHOFF = 0, SVSMHLP = 0, SVSMHTH = 7, DC (dDV _{CC} /dt < 1 V/s)	2.92	3.01	3.12	

Table 5-22. PSS, SVSMH (continued)

over recommended ranges of supply voltage and operating free-air temperature (unless otherwise noted)

PARAMETER		TEST CONDITIONS	MIN	TYP	MAX	UNIT
$V_{SVSMH-LP}$	SVSM _H threshold level, low-power mode (falling DV _{CC})	SVSMHOFF = 0, SVSMHLP = 1, SVSMHTH = 0, DC (dDV _{CC} /dt < 1 V/s)	1.55	1.62	1.71	V
		SVSMHOFF = 0, SVSMHLP = 1, SVSMHTH = 1, DC (dDV _{CC} /dt < 1 V/s)	1.55	1.62	1.71	
		SVSMHOFF = 0, SVSMHLP = 1, SVSMHTH = 2, DC (dDV _{CC} /dt < 1 V/s)	1.55	1.62	1.71	
		SVSMHOFF = 0, SVSMHLP = 1, SVSMHTH = 3, DC (dDV _{CC} /dt < 1 V/s)	2.0	2.09	2.18	
		SVSMHOFF = 0, SVSMHLP = 1, SVSMHTH = 4, DC (dDV _{CC} /dt < 1 V/s)	2.2	2.3	2.4	
		SVSMHOFF = 0, SVSMHLP = 1, SVSMHTH = 5, DC (dDV _{CC} /dt < 1 V/s)	2.4	2.51	2.62	
		SVSMHOFF = 0, SVSMHLP = 1, SVSMHTH = 6, DC (dDV _{CC} /dt < 1 V/s)	2.7	2.83	2.94	
		SVSMHOFF = 0, SVSMHLP = 1, SVSMHTH = 7, DC (dDV _{CC} /dt < 1 V/s)	2.87	3.0	3.13	
V_{SVSMH_hys}	SVSM _H hysteresis			15	30	mV
$t_{PD,SVSMH}$	SVS _H propagation delay, high-performance mode	SVSMHOFF = 0, SVSMHLP = 0, very fast dV _{DVCC} /dt		3	10	μs
	SVS _H propagation delay, low-power mode	SVSMHOFF = 0, SVSMHLP = 1, very fast dV _{DVCC} /dt		25	100	
$t_{(SVSMH)}$	SVSM _H on or off delay time	SVSMHOFF = 1 → 0, SVSMHLP = 0 ⁽¹⁾		17	40	μs

- (1) If the SVSMH is disabled in active mode and is enabled before entering a low-power mode of the device (LPM3, LPM4, LPM3.5, or LPM4.5) ensure that sufficient time has elapsed since enabling of the module before entry into the device low-power mode to allow for successful wake up of the SVSMH module according to the the SVSMH on or off delay time specification. Otherwise, SVSMH may trip, causing the device to reset and wake up from the low-power mode.

5.26.6 Digital I/Os

Table 5-23 lists the characteristics of the digital inputs.

Table 5-23. Digital Inputs (Applies to Both Normal and High-Drive I/Os)

over recommended ranges of supply voltage and operating free-air temperature (unless otherwise noted)

PARAMETER		TEST CONDITIONS	V _{CC}	MIN	TYP	MAX	UNIT
V _{IT+}	Positive-going input threshold voltage		2.2 V	0.99		1.65	V
			3 V	1.35		2.25	
V _{IT-}	Negative-going input threshold voltage		2.2 V	0.55		1.21	V
			3 V	0.75		1.65	
V _{hys}	Input voltage hysteresis (V _{IT+} – V _{IT-})		2.2 V	0.32		0.84	V
			3 V	0.4		1.0	
R _{Pull}	Pullup or pulldown resistor	For pullup: V _{IN} = V _{SS} , For pulldown: V _{IN} = V _{CC}		20	30	40	kΩ
C _{i,dig}	Input capacitance, digital only port pins	V _{IN} = V _{SS} or V _{CC}			11		pF
C _{i,ana}	Input capacitance, port pins shared with analog functions	V _{IN} = V _{SS} or V _{CC}			11		pF
I _{lkg,ndio}	Normal I/O high-impedance input leakage current	See (1)(2)	2.2 V, 3 V			±20	nA
I _{lkg,hdio}	High-drive I/O high-impedance input leakage current	See (1)(2)	2.2 V, 3 V			±20	nA
t _{int}	External interrupt timing (external trigger pulse duration to set interrupt flag)	Ports with interrupt capability and without glitch filter (3)	2.2 V, 3 V	20			ns
		Ports with interrupt capability and with glitch filter, glitch filter disabled (GLTFLT_EN = 0) (3)	2.2 V, 3 V	20			
		Ports with interrupt capability and with glitch filter, glitch filter enabled (GLTFTL_EN = 1) (4)	2.2 V, 3 V	0.25		1	μs
t _{RST}	External reset pulse duration on RSTn pin(5)		2.2 V, 3 V	1			μs

- (1) The input leakage current is measured with V_{SS} or V_{CC} applied to the corresponding pins, unless otherwise noted.
- (2) The input leakage of the digital port pins is measured individually. The port pin is selected for input and the pullup/pulldown resistor is disabled.
- (3) An external signal sets the interrupt flag every time the minimum interrupt pulse duration t_{int} is met. It may be set by trigger signals shorter than t_{int}.
- (4) A trigger pulse duration less than the MIN value is always filtered, and a trigger pulse duration more than the MAX value is always passed. The trigger pulse may or may not be filtered if the duration is between the MIN and MAX values.
- (5) Not applicable if RSTn/NMI pin configured as NMI.

Table 5-24 lists the characteristics of the normal-drive digital outputs. See Figure 5-19, Figure 5-20, Figure 5-21, and Figure 5-22 for the typical characteristics graphs.

Table 5-24. Digital Outputs, Normal I/Os

over recommended ranges of supply voltage and operating free-air temperature (unless otherwise noted)

PARAMETER		TEST CONDITIONS	V _{CC}	MIN	MAX	UNIT
V _{OH}	High-level output voltage	I _(OHmax) = -1 mA ⁽¹⁾	2.2 V	V _{CC} - 0.25	V _{CC}	V
		I _(OHmax) = -3 mA ⁽²⁾		V _{CC} - 0.60	V _{CC}	
		I _(OHmax) = -2 mA ⁽¹⁾	3.0 V	V _{CC} - 0.25	V _{CC}	
		I _(OHmax) = -6 mA ⁽²⁾		V _{CC} - 0.60	V _{CC}	
V _{OL}	Low-level output voltage	I _(OLmax) = 1 mA ⁽¹⁾	2.2 V	V _{SS}	V _{SS} + 0.25	V
		I _(OLmax) = 3 mA ⁽²⁾		V _{SS}	V _{SS} + 0.60	
		I _(OLmax) = 2 mA ⁽¹⁾	3.0 V	V _{SS}	V _{SS} + 0.25	
		I _(OLmax) = 6 mA ⁽²⁾		V _{SS}	V _{SS} + 0.60	
f _{Px,y}	Port output frequency (with RC load) ⁽³⁾	V _{CORE} = 1.4 V, C _L = 20 pF, R _L ^{(4) (5)}	1.62 V	24		MHz
			2.2 V	24		
			3.0 V	24		
d _{Px,y}	Port output duty cycle (with RC Load)	V _{CORE} = 1.4 V, C _L = 20 pF, R _L ^{(4) (5)}	1.62 V	40%	60%	
			2.2 V	40%	60%	
			3.0 V	45%	55%	
f _{Port_CLK}	Clock output frequency ⁽³⁾	V _{CORE} = 1.4 V, C _L = 20 pF ⁽⁵⁾	1.62 V	24		MHz
			2.2 V	24		
			3.0 V	24		
d _{Port_CLK}	Clock output duty cycle	V _{CORE} = 1.4 V, C _L = 20 pF ⁽⁵⁾	1.62 V	40%	60%	
			2.2 V	40%	60%	
			3.0 V	45%	55%	
t _{rise,dig}	Port output rise time, digital only port pins	C _L = 20 pF ⁽⁶⁾	1.62 V		8	ns
			2.2 V		5	
			3.0 V		3	
t _{fall,dig}	Port output fall time, digital only port pins	C _L = 20 pF ⁽⁷⁾	1.62 V		8	ns
			2.2 V		5	
			3.0 V		3	
t _{rise,ana}	Port output rise time, port pins with shared analog functions	C _L = 20 pF ⁽⁶⁾	1.62 V		8	ns
			2.2 V		5	
			3.0 V		3	
t _{fall,ana}	Port output fall time, port pins with shared analog functions	C _L = 20 pF ⁽⁷⁾	1.62 V		8	ns
			2.2 V		5	
			3.0 V		3	

- (1) The maximum total current, I_(OHmax) and I_(OLmax), for all outputs combined should not exceed ±48 mA to hold the maximum voltage drop specified.
- (2) The maximum total current, I_(OHmax) and I_(OLmax), for all outputs combined should not exceed ±100 mA to hold the maximum voltage drop specified.
- (3) The port can output frequencies at least up to the specified limit - it might support higher frequencies.
- (4) A resistive divider with 2 × R1 and R1 = 3.2 kΩ between V_{CC} and V_{SS} is used as load. The output is connected to the center tap of the divider. C_L = 20 pF is connected to the output to V_{SS}.
- (5) The output voltage reaches at least 20% and 80% V_{CC} at the specified toggle frequency.
- (6) Measured from 20% of V_{CC} to 80% of V_{CC}.
- (7) Measured from 80% of V_{CC} to 20% of V_{CC}.

Table 5-25 lists the characteristics of the high-drive digital outputs. See Figure 5-23, Figure 5-24, Figure 5-25, and Figure 5-26 for the typical characteristics graphs.

Table 5-25. Digital Outputs, High-Drive I/Os

over recommended ranges of supply voltage and operating free-air temperature (unless otherwise noted)

PARAMETER	TEST CONDITIONS	V _{CC}	MIN	MAX	UNIT
V _{OH} High-level output voltage	I _(OHmax) = -5 mA ⁽¹⁾	2.2 V	V _{CC} - 0.25	V _{CC}	V
	I _(OHmax) = -15 mA ⁽²⁾		V _{CC} - 0.60	V _{CC}	
	I _(OHmax) = -10 mA ⁽¹⁾	3.0 V	V _{CC} - 0.25	V _{CC}	
	I _(OHmax) = -20 mA ⁽²⁾		V _{CC} - 0.50	V _{CC}	
V _{OL} Low-level output voltage	I _(OLmax) = 5 mA ⁽¹⁾	2.2 V	V _{SS}	V _{SS} + 0.25	V
	I _(OLmax) = 15 mA ⁽²⁾		V _{SS}	V _{SS} + 0.60	
	I _(OLmax) = 10 mA ⁽¹⁾	3.0 V	V _{SS}	V _{SS} + 0.25	
	I _(OLmax) = 20 mA ⁽²⁾		V _{SS}	V _{SS} + 0.50	
f _{Px,y} Port output frequency (with RC load) ⁽³⁾	V _{CORE} = 1.4 V, C _L = 80 pF, R _L ^{(4) (5)}	1.62 V	24		MHz
		2.2 V	24		
		3.0 V	24		
d _{Px,y} Port output duty cycle (with RC Load)	V _{CORE} = 1.4 V, C _L = 80 pF, R _L ^{(4) (5)}	1.62 V	45%	55%	
		2.2 V	45%	55%	
		3.0 V	45%	55%	
f _{Port_CLK} Clock output frequency ⁽³⁾	V _{CORE} = 1.4 V, C _L = 80 pF ⁽⁵⁾	1.62 V	24		MHz
		2.2 V	24		
		3.0 V	24		
d _{Port_CLK} Clock output duty cycle	V _{CORE} = 1.4 V, C _L = 80 pF ⁽⁵⁾	1.62 V	45%	55%	
		2.2 V	45%	55%	
		3.0 V	45%	55%	
t _{rise} Port output rise time	C _L = 80 pF ⁽⁶⁾	1.62 V		8	ns
		2.2 V		5	
		3.0 V		3	
t _{fall} Port output fall time	C _L = 80 pF ⁽⁷⁾	1.62 V		8	ns
		2.2 V		5	
		3.0 V		3	

- (1) The maximum total current, I_(OHmax) and I_(OLmax), for all outputs combined should not exceed ±48 mA to hold the maximum voltage drop specified.
- (2) The maximum total current, I_(OHmax) and I_(OLmax), for all outputs combined should not exceed ±100 mA to hold the maximum voltage drop specified.
- (3) The port can output frequencies at least up to the specified limit, and it might support higher frequencies.
- (4) A resistive divider with 2 × R1 and R1 = 3.2 kΩ between V_{CC} and V_{SS} is used as load. The output is connected to the center tap of the divider. C_L = 80 pF is connected to the output to V_{SS}.
- (5) The output voltage reaches at least 20% and 80% V_{CC} at the specified toggle frequency.
- (6) Measured from 20% of V_{CC} to 80% of V_{CC}.
- (7) Measured from 80% of V_{CC} to 20% of V_{CC}.

Table 5-26 lists the frequencies of the pin-oscillator ports. See Figure 5-27 and Figure 5-28 for the typical characteristics graphs.

Table 5-26. Pin-Oscillator Frequency, Ports Px

over recommended ranges of supply voltage and operating free-air temperature (unless otherwise noted)

PARAMETER	TEST CONDITIONS	V _{CC}	MIN	TYP	MAX	UNIT
f _{OPx,y} Pin-oscillator frequency	Px,y, C _L = 10 pF ⁽¹⁾	3.0 V		1900		kHz
	Px,y, C _L = 20 pF ⁽¹⁾	3.0 V		1150		

- (1) C_L is the external load capacitance connected from the output to V_{SS} and includes all parasitic effects such as PCB traces.

5.26.6.1 Typical Characteristics, Normal-Drive I/O Outputs at 3.0 V and 2.2 V

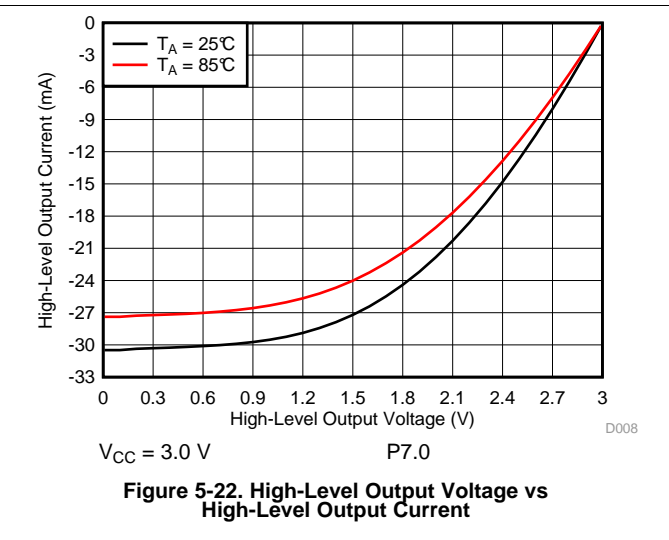
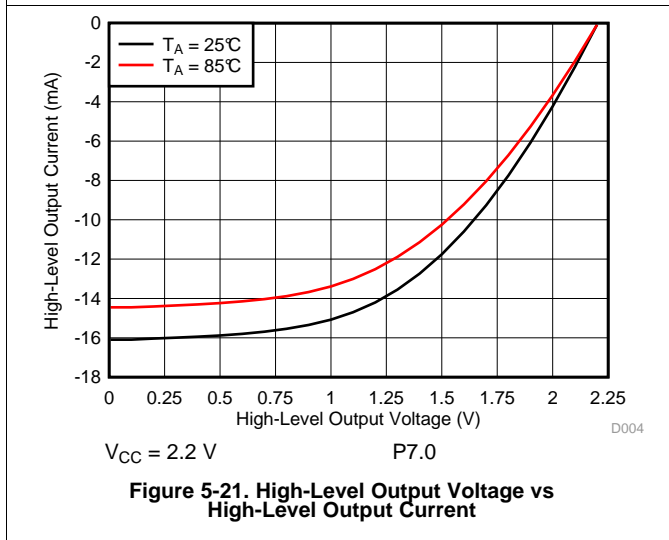
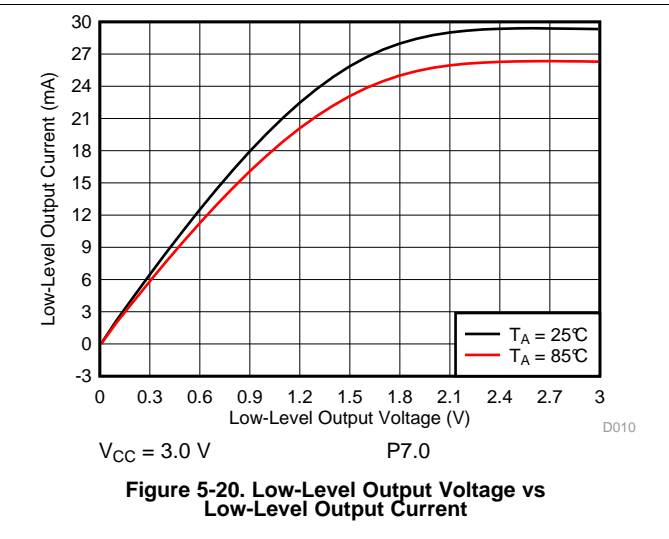
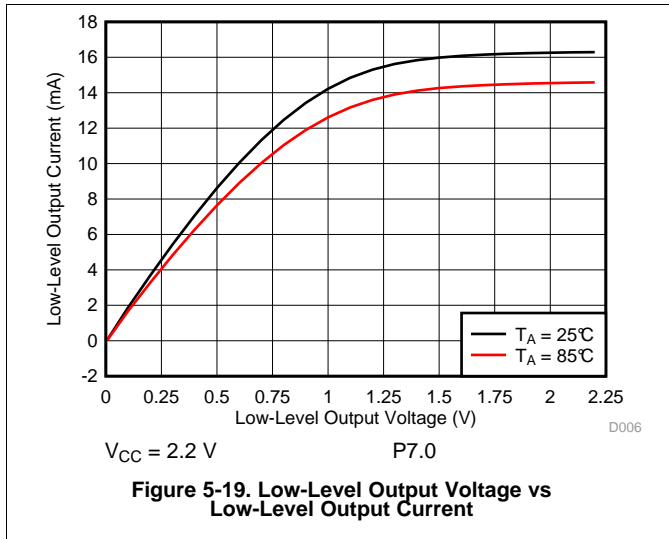

5.26.6.2 Typical Characteristics, High-Drive I/O Outputs at 3.0 V and 2.2 V

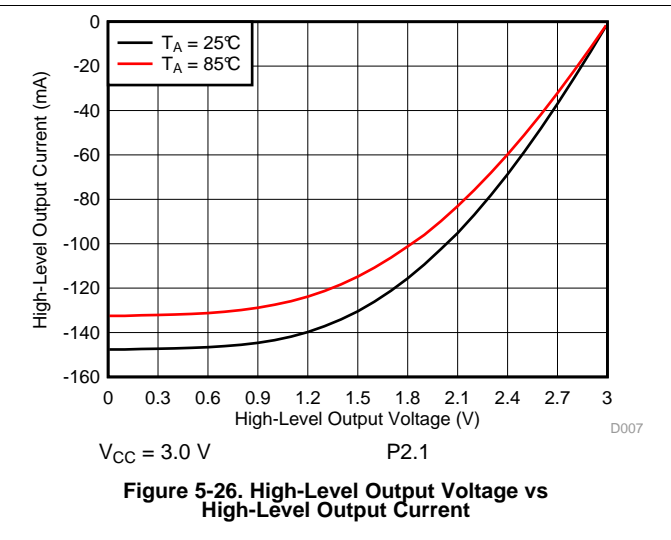
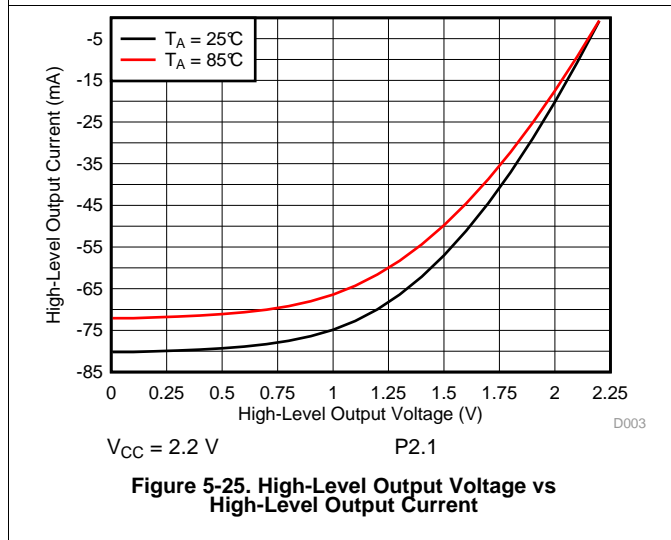
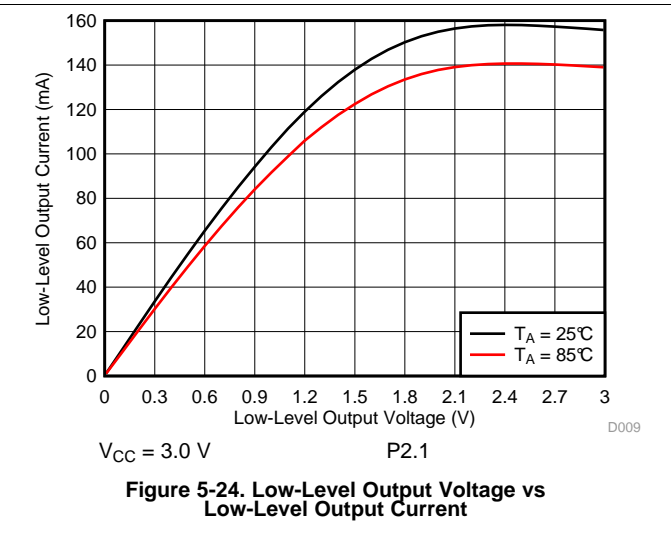
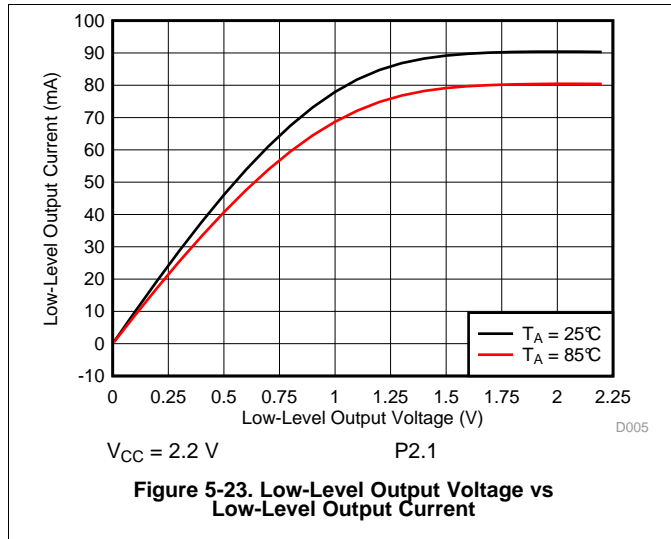

5.26.6.3 Typical Characteristics, Pin-Oscillator Frequency

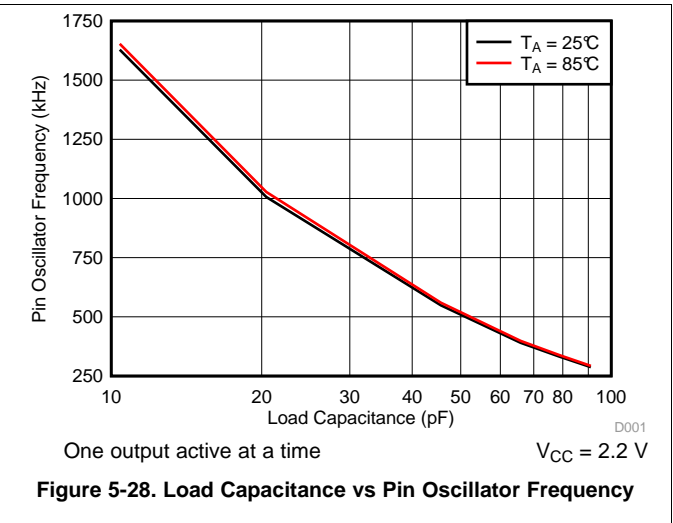
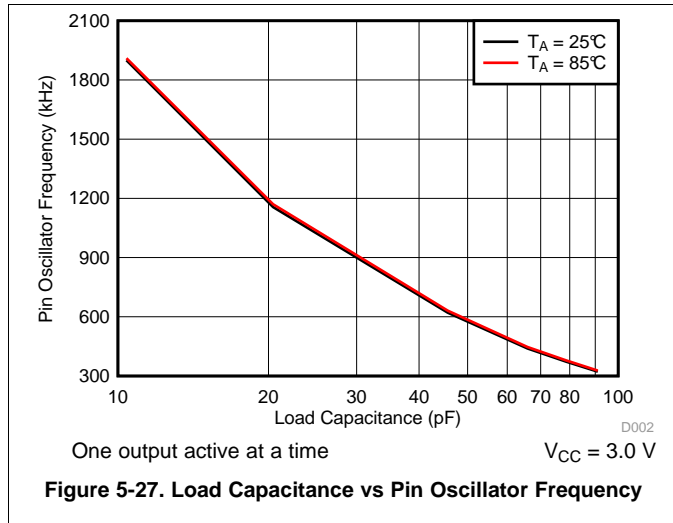

5.26.7 Precision ADC

Table 5-27 lists the power supply and input range conditions for the ADC.

Table 5-27. Precision ADC Power Supply and Input Range Conditions

over recommended ranges of supply voltage and operating free-air temperature (unless otherwise noted)

PARAMETER		TEST CONDITIONS	V _{CC}	MIN	NOM	MAX	UNIT	
AV _{CC}	Analog supply voltage	AVCC and DVCC are connected together, AVSS and DVSS are connected together, V _(AVSS) = V _(DVSS) = 0 V, ADC14PWRMD = 2		1.62		3.7	V	
AV _{CC}	Analog supply voltage	AVCC and DVCC are connected together, AVSS and DVSS are connected together, V _(AVSS) = V _(DVSS) = 0 V, ADC14PWRMD = 0		1.8		3.7	V	
V(A _x)	Analog input voltage range ⁽¹⁾	All ADC analog input pins A _x		0		AVCC	V	
V _{CM}	Input common-mode range	All ADC analog input pins A _x (ADC14DIF = 1)		0	V _{REF} / 2	V _{REF}	V	
I _(ADC14) single-ended mode	Operating supply current into AVCC plus DVCC terminal ⁽²⁾	f _{ADC14CLK} = 25 MHz, 1 Msps (ADC14PWRMD = 0), ADC14ON = 1, ADC14DIF = 0, ADC14VRSEL = 0xE, REFON = 0, ADC14SHT0x = 0x0, ADC14SHT1x = 0x0	3.0 V		490	640	μA	
			2.2 V		450	580		
		f _{ADC14CLK} = 5 MHz, 200 ksps (ADC14PWRMD = 2), ADC14ON = 1, ADC14DIF = 0, ADC14VRSEL = 0xE, REFON = 0, ADC14SHT0x = 0x0, ADC14SHT1x = 0x0	3.0 V		215	270		
			2.2 V		210	260		
I _(ADC14) differential mode	Operating supply current into AVCC plus DVCC terminal ⁽²⁾	f _{ADC14CLK} = 25 MHz, 1 Msps (ADC14PWRMD = 0), ADC14ON = 1, ADC14DIF = 1, ADC14VRSEL = 0xE, REFON = 0, ADC14SHT0x = 0x0, ADC14SHT1x = 0x0	3.0 V		690	875	μA	
			2.2 V		620	785		
		f _{ADC14CLK} = 5 MHz, 200 ksps (ADC14PWRMD = 2), ADC14ON = 1, ADC14DIF = 1, ADC14VRSEL = 0xE, REFON = 0, ADC14SHT0x = 0x0, ADC14SHT1x = 0x0	3.0 V		275	335		
			2.2 V		260	320		
C _I	Input capacitance into a single terminal ⁽³⁾			12		15	pF	
R _I	Input MUX ON-resistance	0 V ≤ V _(A_x) ≤ AVCC	1.8 V to 3.7 V		0.135		1	kΩ
			1.62 V to <1.8 V		0.15		1.5	

(1) The analog input voltage range must be within the selected reference voltage range V_{R+} to V_{R-} for valid conversion results.

(2) The internal reference supply current is not included in current consumption parameter I_(ADC14).

(3) Represents only the ADC switching capacitance. See the digital inputs electrical specification for internal parasitic pin capacitance.

Table 5-28 lists the timing parameters of the ADC.

Table 5-28. Precision ADC Timing Parameters

over recommended ranges of supply voltage and operating free-air temperature (unless otherwise noted)

PARAMETER		TEST CONDITIONS	V _{CC}	MIN	TYP	MAX	UNIT
f _{ADC14CLK}	ADC clock frequency ⁽¹⁾	ADC14PWRMD = 0	1.8 V to 3.7 V	0.128		25	MHz
		ADC14PWRMD = 2	1.62 V to 3.7 V	0.128		5.75	
N _{CONVERT}	Clock cycles for conversion	ADC14RES = 11			16		cycles
		ADC14RES = 10			14		
		ADC14RES = 01			11		
		ADC14RES = 00			9		
t _{ADC14ON}	Turnon settling time of ADC	See ⁽²⁾				1.5	μs
t _{Sample}	Sampling time ^{(3) (4)}	R _S = 200 Ω, C _{pext} = 10 pF, R _I = 1 kΩ, C _I = 15 pF, C _{pint} = 5 pF		0.215			μs

(1) MODOSC can be used for 1 Msps and SYSOSC can be used for 200 ksps sampling rate operations of ADC.

(2) The condition is that the error in a conversion started after t_{ADC14ON} is less than ±1 LSB. The reference and input signal are already settled.

(3) Sampling time should be at least 4 × (1 / f_{ADC14CLK}).

(4) t_{sample} ≥ (n + 1) × ln(2) × [(R_S + R_I) × C_I + R_S × (C_{pext} + C_{pint})], where n = ADC resolution = 14, R_S = external source resistance, C_{pext} = external parasitic capacitance.

Table 5-29 lists the linearity parameters of the ADC.

Table 5-29. Precision ADC Linearity Parameters⁽¹⁾⁽²⁾

over recommended ranges of supply voltage and operating free-air temperature (unless otherwise noted)

PARAMETER		TEST CONDITIONS	MIN	TYP	MAX	UNIT
Resolution				14		bits
E _I	Integral linearity error (INL)				±2.3	LSB
E _D	Differential linearity error (DNL)		-0.99		1	LSB
E _O	Offset error	ADC14VRSEL = 0xE, 0xF		±0.2	±1	mV
		ADC14VRSEL = 0x1		±1.2	±2	
E _G	Gain error	ADC14VRSEL = 0xE		±2	±4	LSB
		ADC14VRSEL = 0xF		±20	±60	
		ADC14VRSEL = 0x1		±50	±180	
E _T	Total unadjusted error	ADC14VRSEL = 0xE		±4	±15	LSB
		ADC14VRSEL = 0xF		±22	±62	
		ADC14VRSEL = 0x1		±55	±185	

(1) Minimum reference voltage of 1.45 V is necessary to meet the specified accuracy. Lower reference voltage down to 1.2 V can be applied for 1-Msps sampling rate with reduced accuracy requirements.

(2) Connect the VeREF- pin to onboard ground for ADC14VRSEL = 0xE.

Table 5-30 lists the dynamic parameters of the ADC.

Table 5-30. Precision ADC Dynamic Parameters⁽¹⁾

over recommended ranges of supply voltage and operating free-air temperature (unless otherwise noted)

PARAMETER		TEST CONDITIONS	MIN	TYP	MAX	UNIT
SINAD ⁽²⁾	Signal-to-noise and distortion	1 Msps, ADC14DIF = 0, ADC14VRSEL = 0xE, 2.5-V reference, 20-kHz input sine, LDO based operation	71	73		dB
		1 Msps, ADC14DIF = 0, ADC14VRSEL = 0xE, 2.5-V reference, 20-kHz input sine, DC/DC based operation	62	70		
		1 Msps, ADC14DIF = 1, ADC14VRSEL = 0xE, 2.5-V reference, 20-kHz input sine	79	81		
ENOB ⁽²⁾	Effective number of bits	1 Msps, ADC14DIF = 0, ADC14VRSEL = 0xE, 2.5-V reference, 20-kHz input sine, LDO based operation	11.5	11.8		bit
		1 Msps, ADC14DIF = 0, ADC14VRSEL = 0xE, 2.5-V reference, 20-kHz input sine, DC/DC based operation	10	11.3		
		1 Msps, ADC14DIF = 1, ADC14VRSEL = 0xE, 2.5-V reference, 20-kHz input sine	12.8	13.2		
CMRR_DC	Common-mode rejection ratio, DC	Common-mode input signal = 0 to VREF pp at DC, ADC14DIF = 1	70	85		dB
CMRR_AC	Common-mode rejection ratio, AC	Common-mode input signal = 0 to VREF pp at 1 MHz, ADC14DIF = 1	55	65		dB
PSRR_DC	Power supply rejection ratio, DC	AV _{CC} = AV _{CC} (min) to AV _{CC} (max), ADC14DIF = 0, ADC14VRSEL = 0xE		1	2.5	mV/V
		AV _{CC} = AV _{CC} (min) to AV _{CC} (max), ADC14DIF = 1, ADC14VRSEL = 0xE		50	150	μV/V
PSRR_AC	Power supply rejection ratio, AC	dAV _{CC} = 0.1 V at 1 kHz, ADC14DIF = 0, ADC14VRSEL = 0xE		1		mV/V
		dAV _{CC} = 0.1 V at 1 kHz, ADC14DIF = 1, ADC14VRSEL = 0xE		50		μV/V

(1) VeREF- pin should be connected to onboard ground for ADC14VRSEL = 0xE.

(2) ADC clock derived from HFXT oscillator.

Table 5-31 lists the characteristics of the temperature sensor and built-in $V_{1/2}$.

Table 5-31. Precision ADC Temperature Sensor and Built-In $V_{1/2}$

over recommended ranges of supply voltage and operating free-air temperature (unless otherwise noted)

PARAMETER		TEST CONDITIONS	V_{CC}	MIN	TYP	MAX	UNIT
V_{SENSOR}	Temperature sensor voltage ^{(1) (2)} (see Figure 5-29)	ADC14ON = 1, ADC14TCMAP = 1, $T_A = 0^\circ\text{C}$			685		mV
TC_{SENSOR}	Change in voltage with temperature ⁽²⁾	ADC14ON = 1, ADC14TCMAP = 1			1.9		mV/ $^\circ\text{C}$
t_{SENSOR} (sample)	Sample time required if ADCTCMAP = 1 and channel (MAX – 1) is selected ⁽³⁾	ADC14ON = 1, ADC14TCMAP = 1, Error of conversion result ≤ 1 LSB			5		μs
$V_{1/2}$	AVCC voltage divider for ADC14BATMAP = 1 on MAX input channel	ADC14ON = 1, ADC14BATMAP = 1		48%	50%	52%	
$t_{V\ 1/2}$ (sample)	Sample time required if ADC14BATMAP = 1 and channel MAX is selected ⁽⁴⁾	ADC14ON = 1, ADC14BMAP = 1			1		μs

- (1) The temperature sensor offset can be as much as $\pm 35^\circ\text{C}$. TI recommends a single-point calibration to minimize the offset error of the built-in temperature sensor.
- (2) The TLV structure contains calibration values for $30^\circ\text{C} \pm 3^\circ\text{C}$ and $85^\circ\text{C} \pm 3^\circ\text{C}$ for each of the available reference voltage levels. The sensor voltage can be computed as $V_{SENSE} = TC_{SENSOR} \times (\text{Temperature}, ^\circ\text{C}) + V_{SENSOR}$, where TC_{SENSOR} and V_{SENSOR} can be computed from the calibration values for higher accuracy.
- (3) The typical equivalent impedance of the sensor is 250 k Ω . The sample time required includes the sensor-on time $t_{SENSOR(on)}$.
- (4) The on-time $t_{V1/2(on)}$ is included in the sampling time $t_{V1/2(sample)}$. No additional on time is needed.

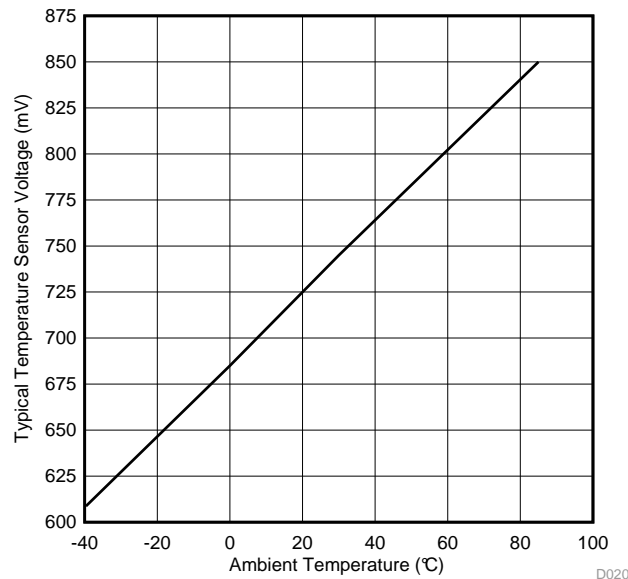

Figure 5-29. Typical Temperature Sensor Voltage

Table 5-32 lists the characteristics of the internal reference buffers of the ADC.

Table 5-32. Precision ADC Internal Reference Buffers

over recommended ranges of supply voltage and operating free-air temperature (unless otherwise noted)

PARAMETER	TEST CONDITIONS	V _{CC}	MIN	TYP	MAX	UNIT
I _{REF+} Operating supply current into AVCC terminal ⁽¹⁾	ADC ON, REFOUT = 0, ADC14PWRMD = 0, REFVSEL = {0, 1, 3}	3 V		600	800	μA
	ADC ON, REFOUT = 0, ADC14PWRMD = 2, REFVSEL = {0, 1, 3}			200	300	
	ADC ON, REFOUT = 1, ADC14PWRMD = 2, REFVSEL = {0, 1, 3}			650	850	
t _{on} Turnon time		3 V			5	μs

(1) The internal reference current is supplied through terminal AVCC.

Table 5-33 lists the characteristics of the ADC external reference.

Table 5-33. Precision ADC External Reference

over recommended ranges of supply voltage and operating free-air temperature (unless otherwise noted)

PARAMETER	TEST CONDITIONS	MIN	TYP	MAX	UNIT
V _{eREF+} Positive external reference voltage input ⁽¹⁾		1.45		AV _{CC}	V
V _{eREF-} Negative external reference voltage input				0	V
(V _{eREF+} - V _{eREF-}) Differential external reference voltage input ⁽¹⁾		1.45		AV _{CC}	V
I _{VeREF+} / I _{VeREF-} Static input current in single ended input mode	1.45 V ≤ V _{eREF+} ≤ V _{AVCC} , V _{eREF-} = 0 V, f _{ADC14CLK} = 25 MHz, ADC14SHT0x = 0x1, ADC14SHT1x = 0x1, ADC14DIF = 0			±75	μA
	1.45 V ≤ V _{eREF+} ≤ V _{AVCC} , V _{eREF-} = 0 V, f _{ADC14CLK} = 5 MHz, ADC14SHT0x = 0x1, ADC14SHT1x = 0x1, ADC14DIF = 0			±15	
I _{VeREF+} / I _{VeREF-} Static input current in differential input mode	1.45 V ≤ V _{eREF+} ≤ V _{AVCC} , V _{eREF-} = 0 V, f _{ADC14CLK} = 25 MHz, ADC14SHT0x = 0x1, ADC14SHT1x = 0x1, ADC14DIF = 1			±150	μA
	1.45 V ≤ V _{eREF+} ≤ V _{AVCC} , V _{eREF-} = 0 V, f _{ADC14CLK} = 5 MHz, ADC14SHT0x = 0x1, ADC14SHT1x = 0x1, ADC14DIF = 1			±30	
C _{VeREF+} Capacitance at VeREF+ terminal	See ⁽²⁾	5			μF

(1) Lower reference voltage down to 1.2 V can be applied for 1-Msps sampling rate with reduced accuracy requirements of linearity parameters.

(2) Connect two decoupling capacitors, 5 μF and 50 nF, to the VeREF+ terminal to decouple the dynamic current required for an external reference source if it is used for the Precision ADC.

5.26.7.1 Typical Characteristics of ADC

typical characteristics at 3 V, 25°C, and 1-Msps sampling rate of ADC (unless otherwise specified)

Table 5-34 lists the ADC typical characteristics graphs.

Table 5-34. ADC Typical Characteristics Graphs

TITLE	TEST CONDITIONS	FIGURE
Current vs Sampling Rate	VRSEL = 14, VREF = 2.5 V, Resolution = 14 Bit, ADC14PWRMD = 0	Figure 5-30
	VRSEL = 14, VREF = 2.5 V, Resolution = 12 Bit, ADC14PWRMD = 2	Figure 5-31
	VRSEL = 1, VREF = 2.5 V, REFOUT = 0, ADC14PWRMD = 0, Resolution = 14 Bit	Figure 5-32
	VRSEL = 1, VREF = 2.5 V, REFOUT = 0, ADC14PWRMD = 2, Resolution = 12 Bit	Figure 5-33
	VRSEL = 1, VREF = 2.5 V, REFOUT = 1, ADC14PWRMD = 2, Resolution = 12 Bit	Figure 5-34
INL vs ADC Output Code	VRSEL = 1, VREF = 2.5 V, Input Mode = Single Ended	Figure 5-35
	VRSEL = 1, VREF = 2.5 V, Input Mode = Differential	Figure 5-36
	VRSEL = 14, VREF = 2.5 V, Input Mode = Single Ended	Figure 5-37
	VRSEL = 14, VREF = 2.5 V, Input Mode = Differential	Figure 5-38
	VRSEL = 15, VREF = 2.5 V, Input Mode = Single Ended	Figure 5-39
	VRSEL = 15, VREF = 2.5 V, Input Mode = Differential	Figure 5-40
DNL vs ADC Output Code	VRSEL = 1, VREF = 2.5 V, Input Mode = Single Ended	Figure 5-41
	VRSEL = 1, VREF = 2.5 V, Input Mode = Differential	Figure 5-42
	VRSEL = 14, VREF = 2.5 V, Input Mode = Single Ended	Figure 5-43
	VRSEL = 14, VREF = 2.5 V, Input Mode = Differential	Figure 5-44
	VRSEL = 15, VREF = 2.5 V, Input Mode = Single Ended	Figure 5-45
	VRSEL = 15, VREF = 2.5 V, Input Mode = Differential	Figure 5-46
Power vs Input Frequency	$f_{in} = 20$ kHz, VRSEL = 1, VREF = 2.5 V, SINAD = 69 dB, THD = -86 dB, Input Mode = Single Ended	Figure 5-47
	$f_{in} = 20$ kHz, VRSEL = 1, VREF = 2.5 V, SINAD = 74 dB, THD = -91 dB, Input Mode = Differential	Figure 5-48
	$f_{in} = 20$ kHz, VRSEL = 14, VREF = 2.5 V, SINAD = 73 dB, THD = -92 dB, Input Mode = Single Ended	Figure 5-49
	$f_{in} = 20$ kHz, VRSEL = 14, VREF = 2.5 V, SINAD = 82 dB, THD = -100 dB, Input Mode = Differential	Figure 5-50
	$f_{in} = 20$ kHz, VRSEL = 15, VREF = 2.5 V, SINAD = 72 dB, THD = -90 dB, Input Mode = Single Ended	Figure 5-51
	$f_{in} = 20$ kHz, VRSEL = 15, VREF = 2.5 V, SINAD = 80 dB, THD = -100 dB, Input Mode = Differential	Figure 5-52
SINAD vs Reference Voltage	$f_{in} = 20$ kHz, VRSEL = 14	Figure 5-53
ENOB vs Reference Voltage	$f_{in} = 20$ kHz, VRSEL = 14	Figure 5-54
THD vs Reference Voltage	$f_{in} = 20$ kHz, VRSEL = 14	Figure 5-55
SFDR vs Reference Voltage	$f_{in} = 20$ kHz, VRSEL = 14	Figure 5-56
SINAD vs Temperature	$f_{in} = 20$ kHz, VRSEL = 14	Figure 5-57
ENOB vs Temperature	$f_{in} = 20$ kHz, VRSEL = 14	Figure 5-58
THD vs Temperature	$f_{in} = 20$ kHz, VRSEL = 14	Figure 5-59
SFDR vs Temperature	$f_{in} = 20$ kHz, VRSEL = 14	Figure 5-60
INL vs Temperature	VRSEL = 14, VREF = 2.5 V, Input Mode = Single Ended	Figure 5-61
	VRSEL = 14, VREF = 2.5 V, Input Mode = Differential	Figure 5-62
DNL vs Temperature	VRSEL = 14, VREF = 2.5 V, Input Mode = Single Ended	Figure 5-63
	VRSEL = 14, VREF = 2.5 V, Input Mode = Differential	Figure 5-64
Offset Voltage vs Temperature	VRSEL = 14, VREF = 2.5 V, Input Mode = Single Ended	Figure 5-65
	VRSEL = 14, VREF = 2.5 V, Input Mode = Differential	Figure 5-66
Gain Error vs Temperature	VRSEL = 14, VREF = 2.5 V, Input Mode = Single Ended	Figure 5-67
	VRSEL = 14, VREF = 2.5 V, Input Mode = Differential	Figure 5-68

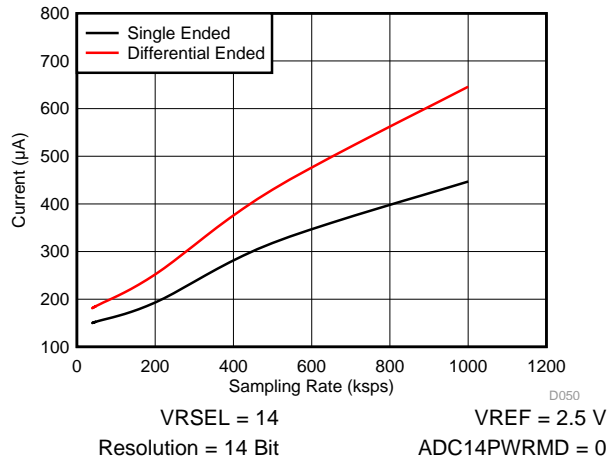

Figure 5-30. Current vs Sampling Rate

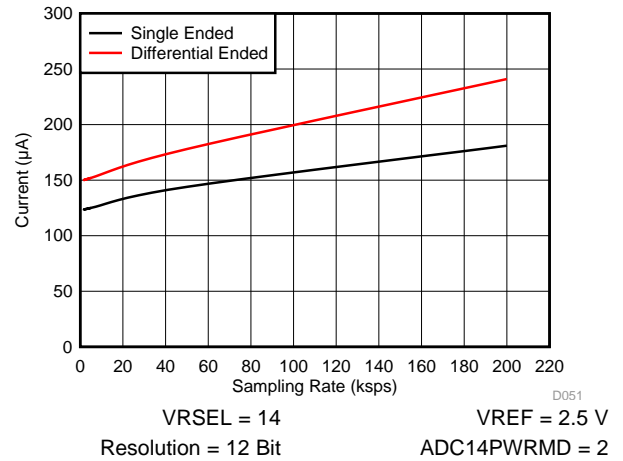

Figure 5-31. Current vs Sampling Rate

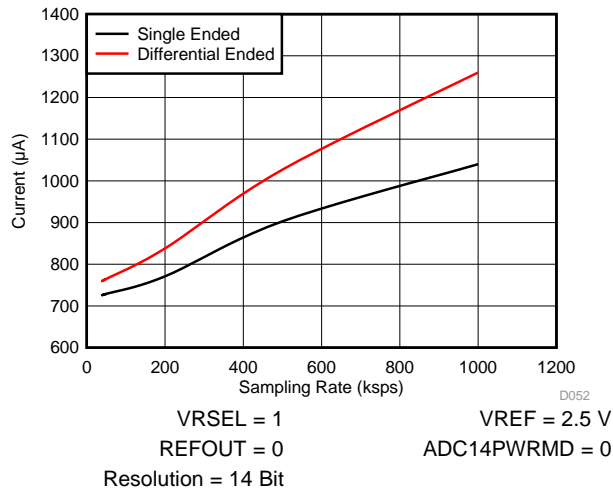

Figure 5-32. Current vs Sampling Rate

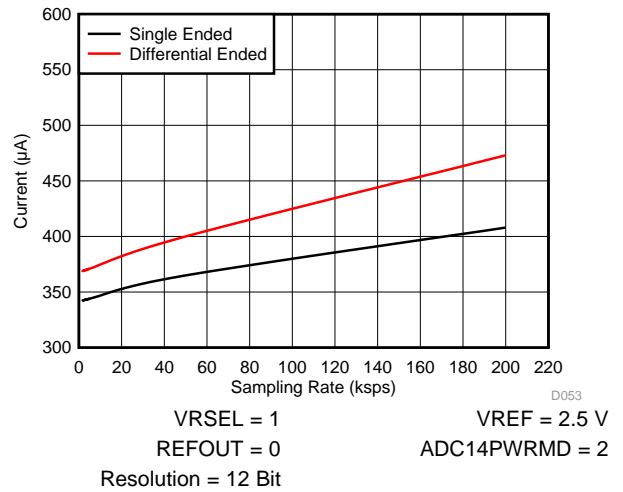

Figure 5-33. Current vs Sampling Rate

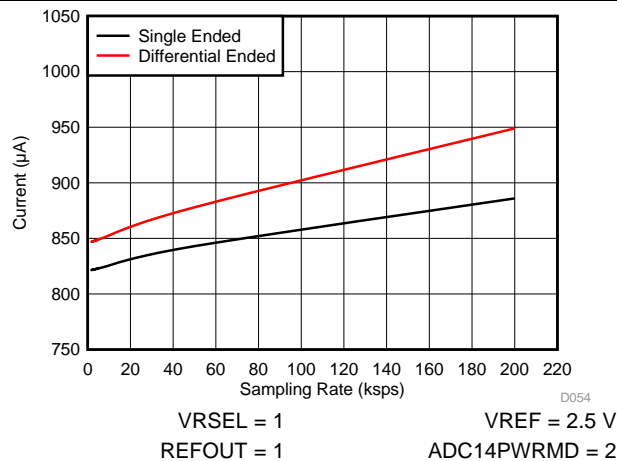

Figure 5-34. Current vs Sampling Rate

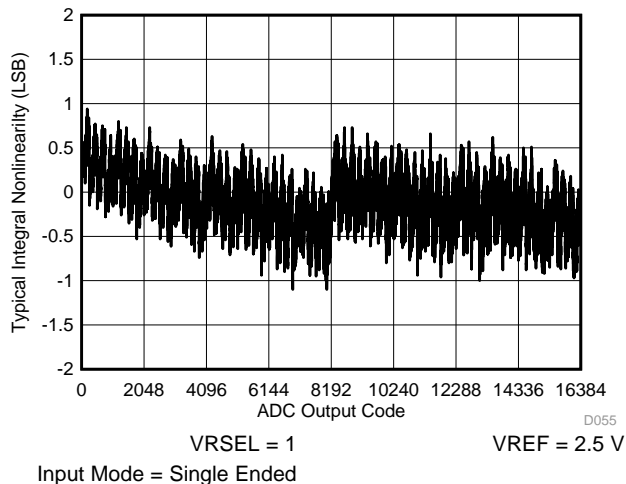

Figure 5-35. INL vs ADC Output Code

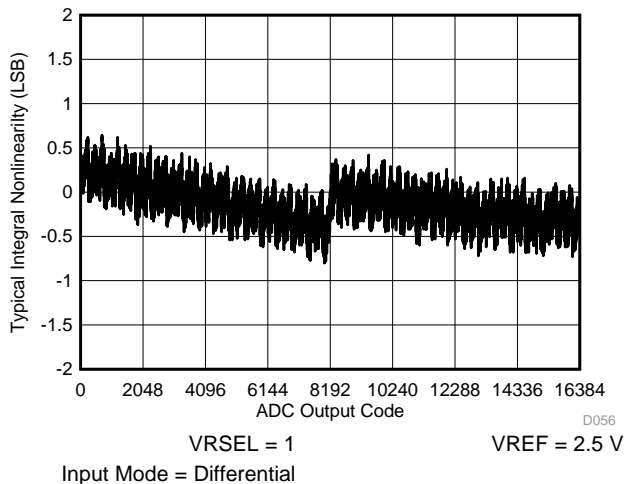

Figure 5-36. INL vs ADC Output Code

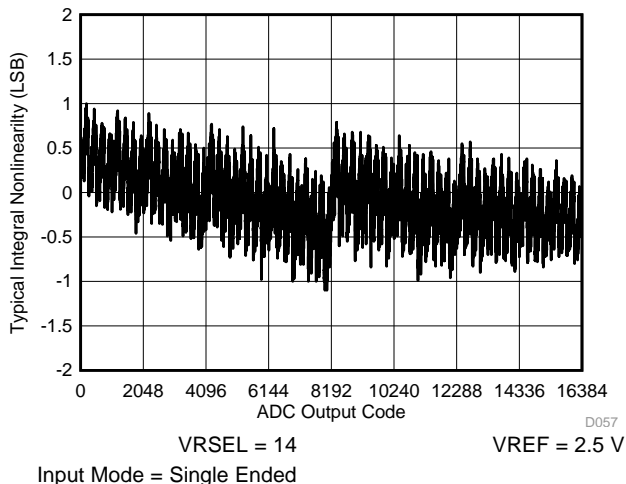

Figure 5-37. INL vs ADC Output Code

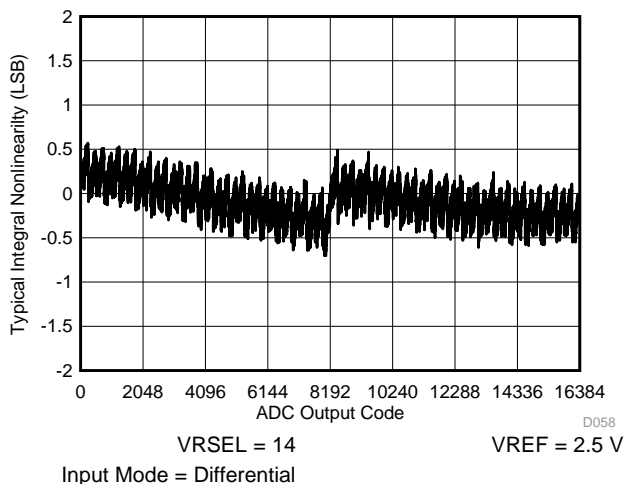

Figure 5-38. INL vs ADC Output Code

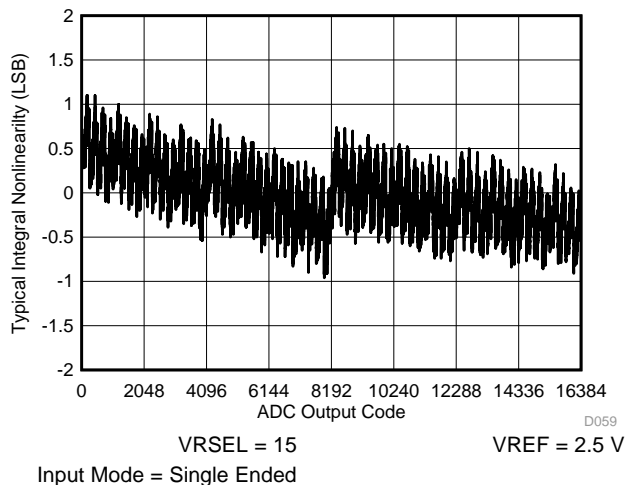

Figure 5-39. INL vs ADC Output Code

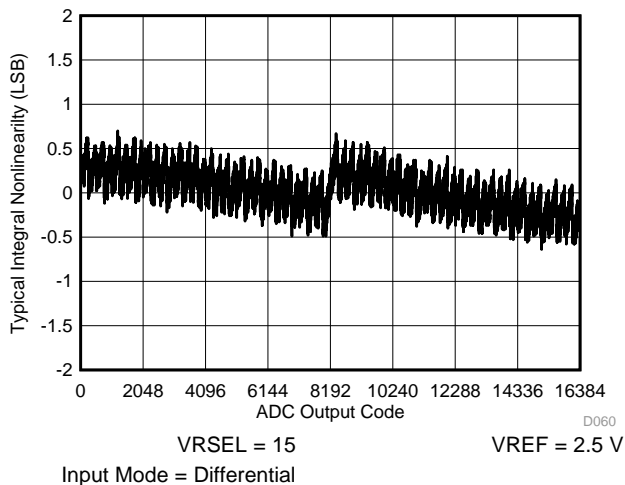

Figure 5-40. INL vs ADC Output Code

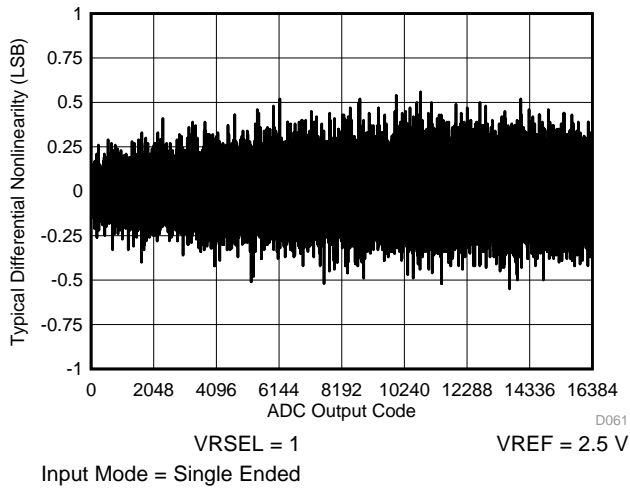

Figure 5-41. DNL vs ADC Output Code

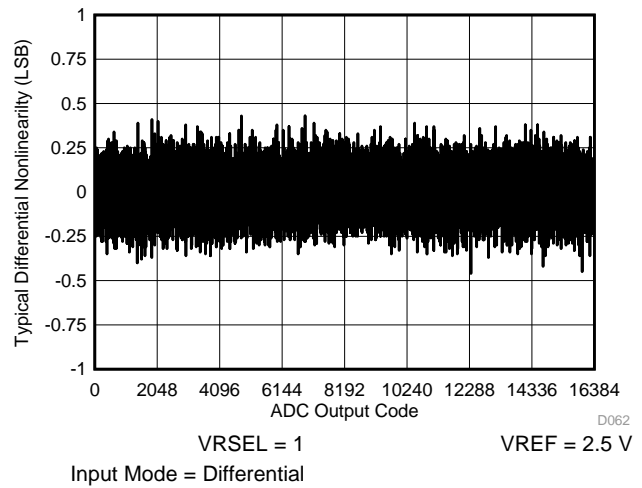

Figure 5-42. DNL vs ADC Output Code

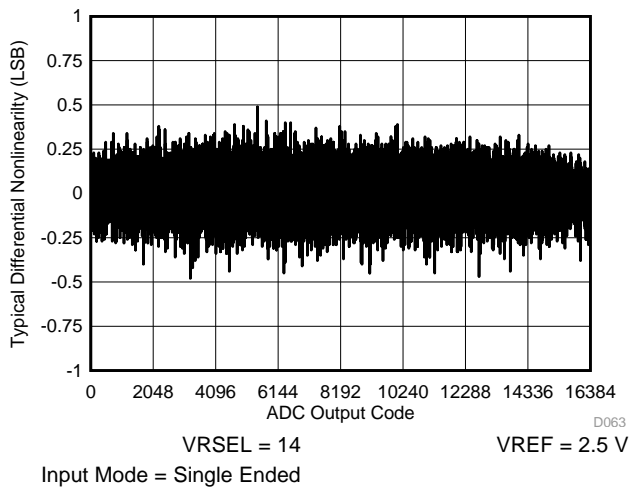

Figure 5-43. DNL vs ADC Output Code

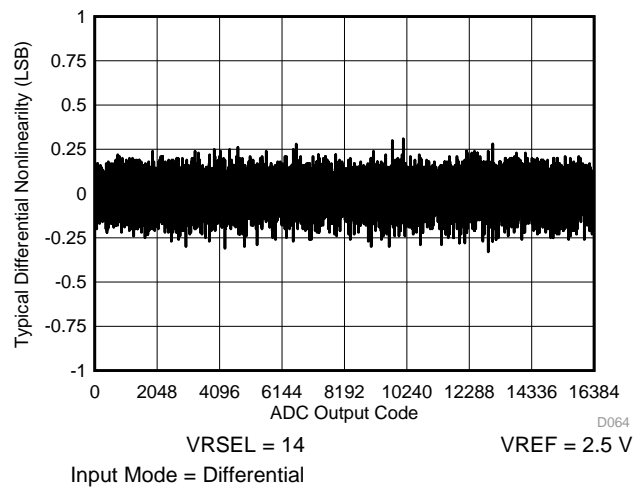

Figure 5-44. DNL vs ADC Output Code

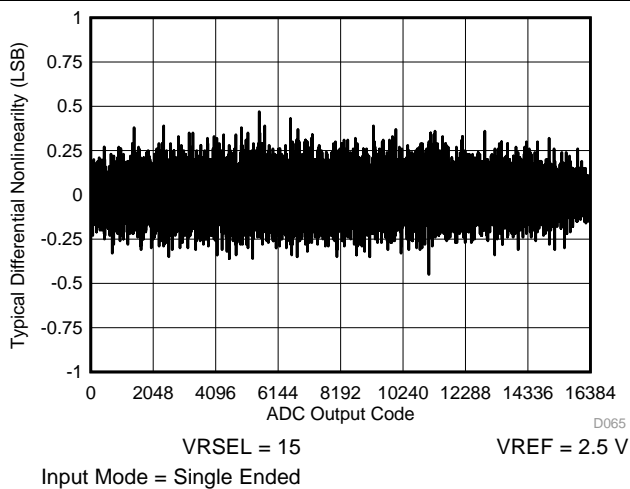

Figure 5-45. DNL vs ADC Output Code

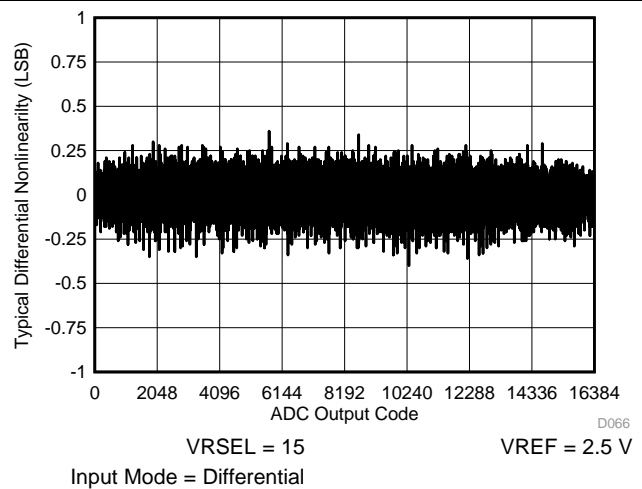

Figure 5-46. DNL vs ADC Output Code

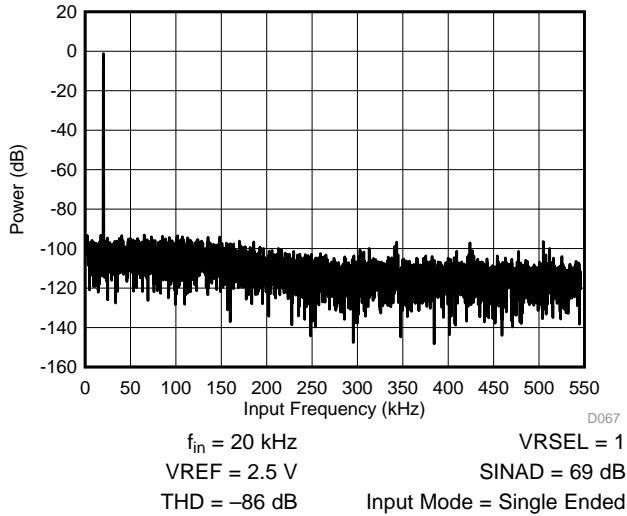

Figure 5-47. Power vs Input Frequency

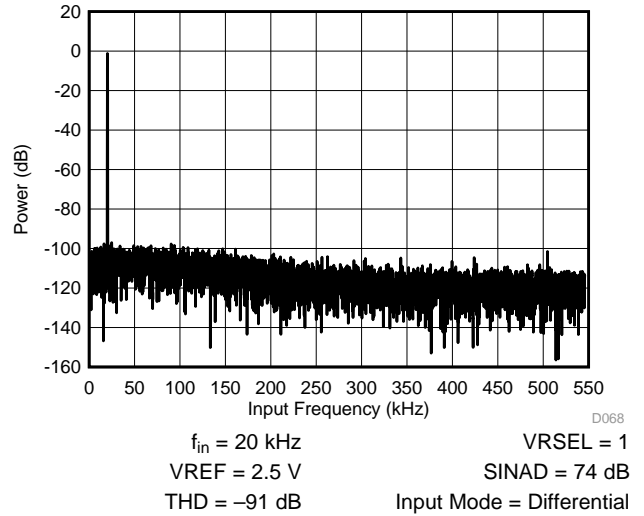

Figure 5-48. Power vs Input Frequency

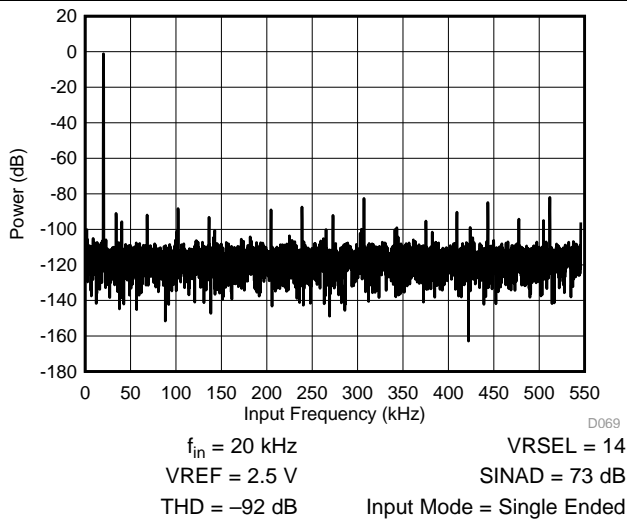

Figure 5-49. Power vs Input Frequency

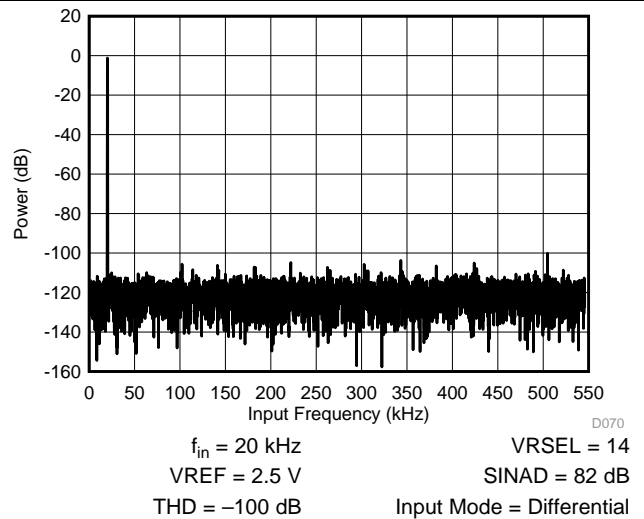

Figure 5-50. Power vs Input Frequency

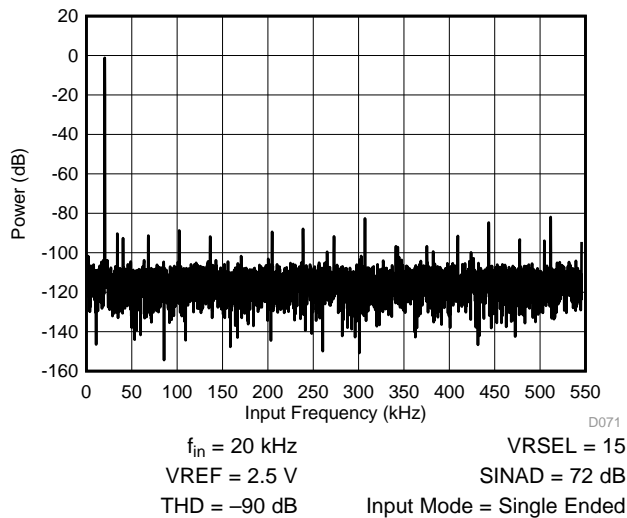

Figure 5-51. Power vs Input Frequency

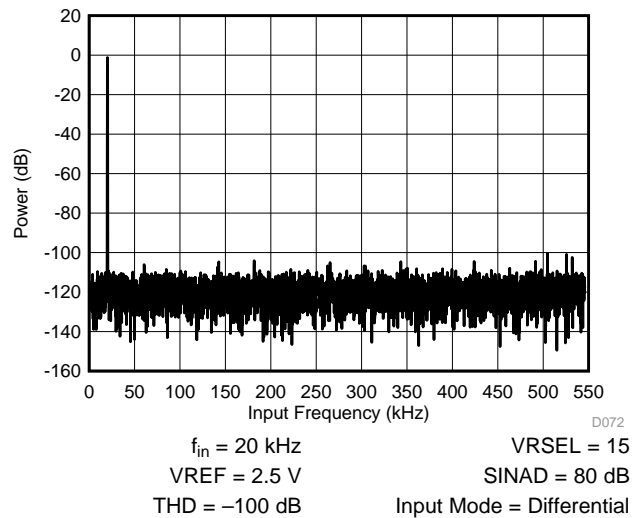

Figure 5-52. Power vs Input Frequency

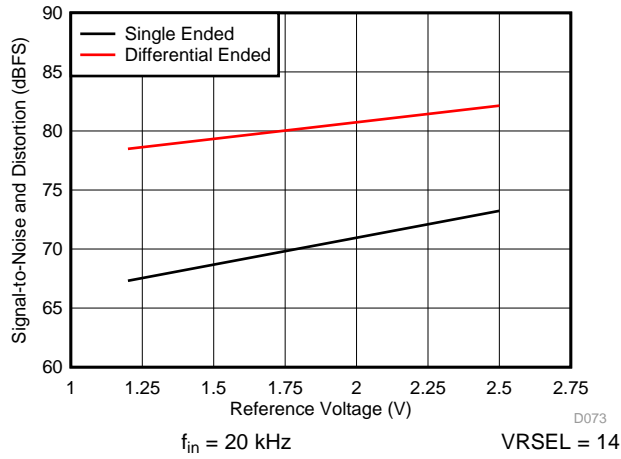

Figure 5-53. SINAD vs Reference Voltage

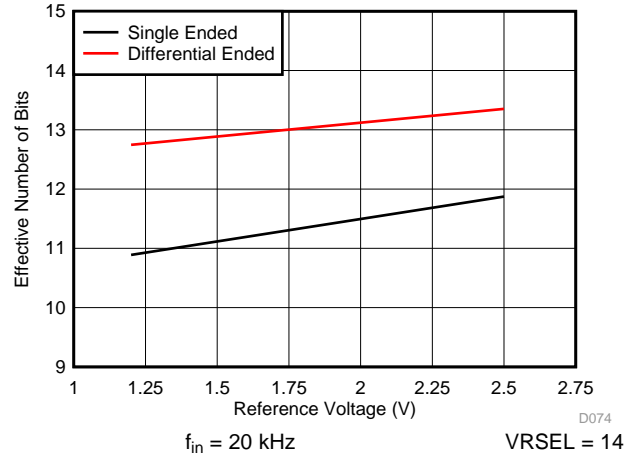

Figure 5-54. ENOB vs Reference Voltage

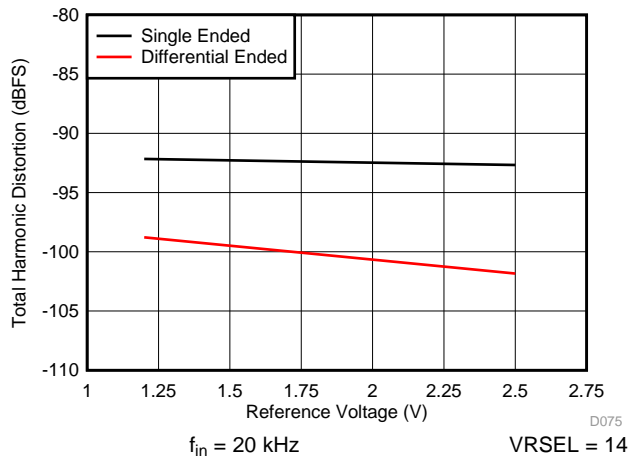

Figure 5-55. THD vs Reference Voltage

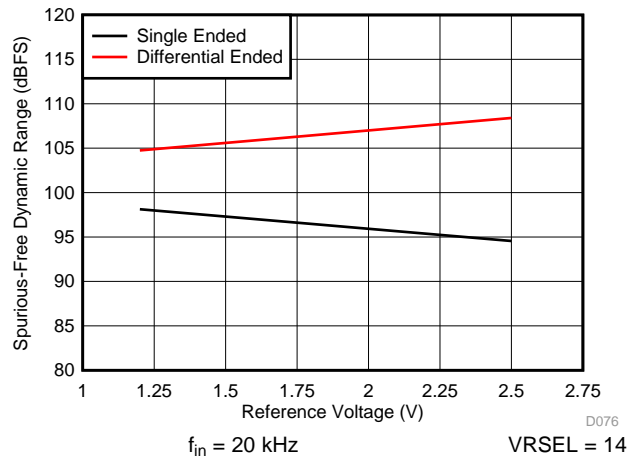

Figure 5-56. SFDR vs Reference Voltage

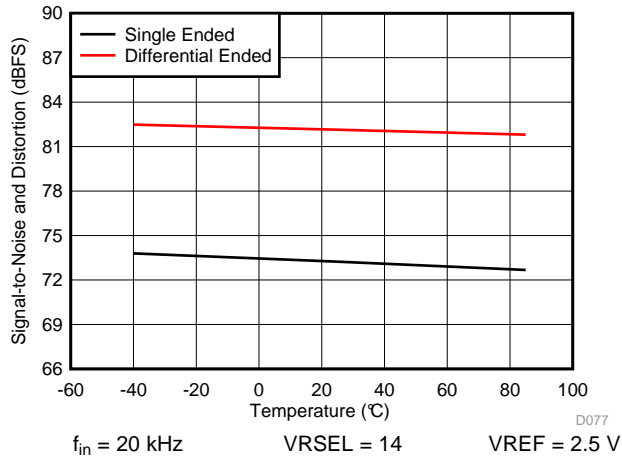

Figure 5-57. SINAD vs Temperature

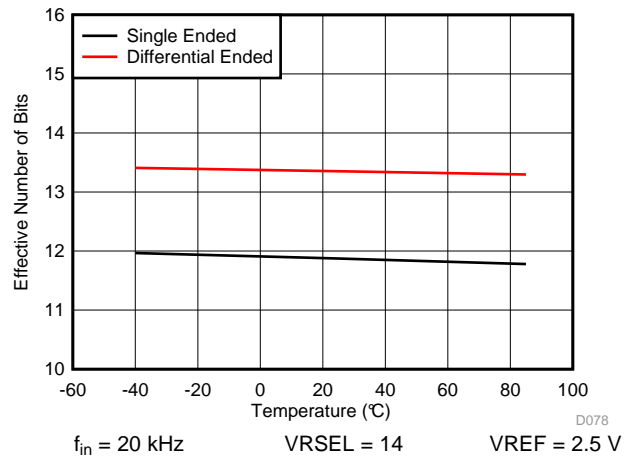

Figure 5-58. ENOB vs Temperature

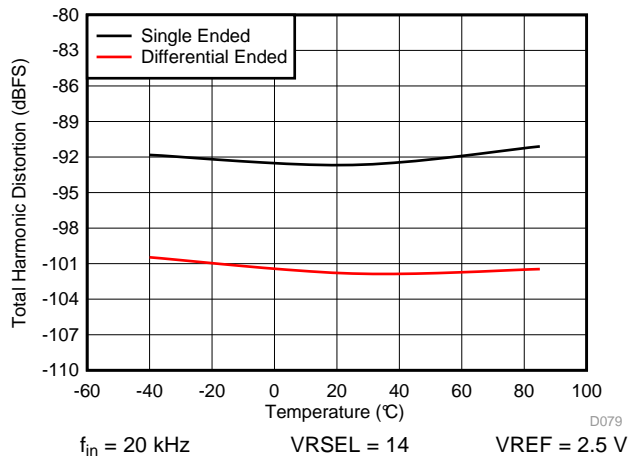

Figure 5-59. THD vs Temperature

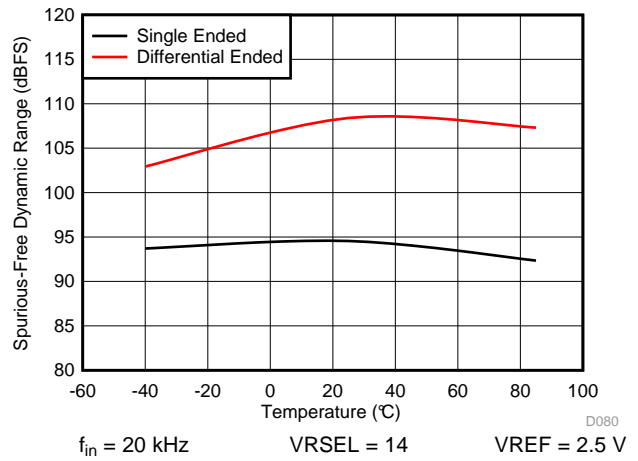
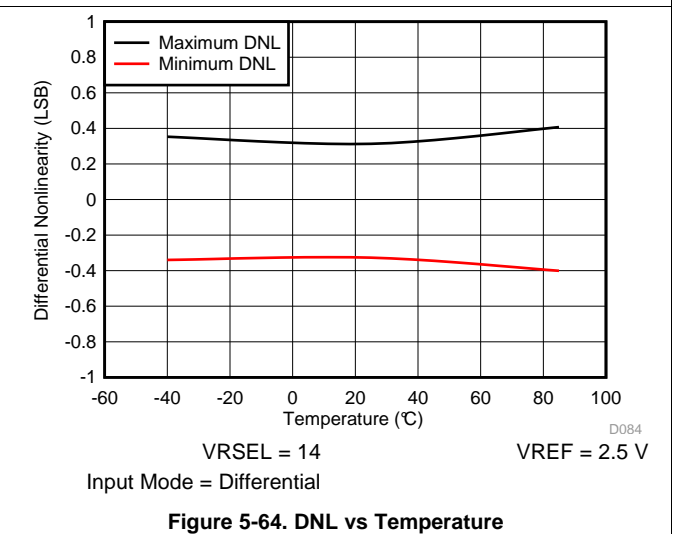
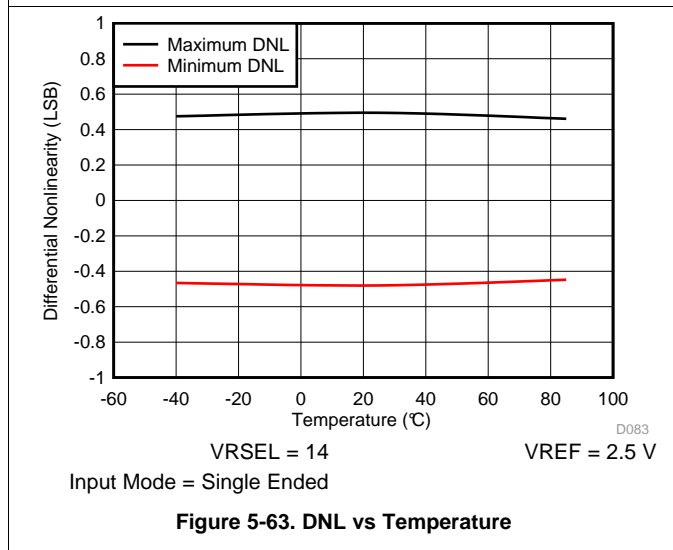
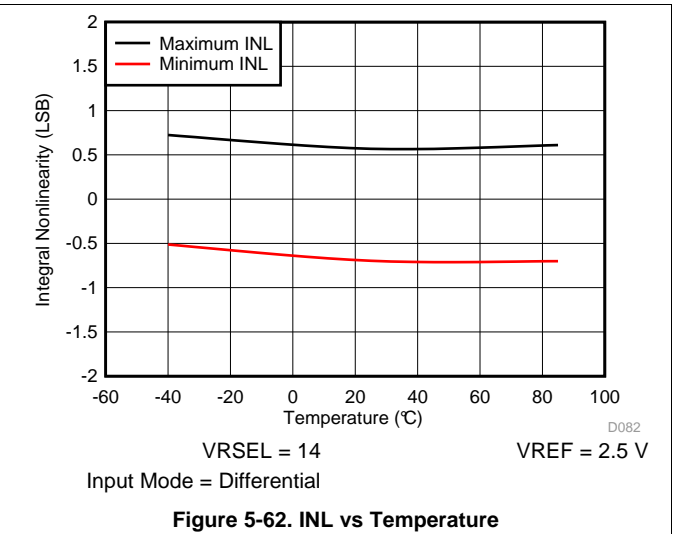
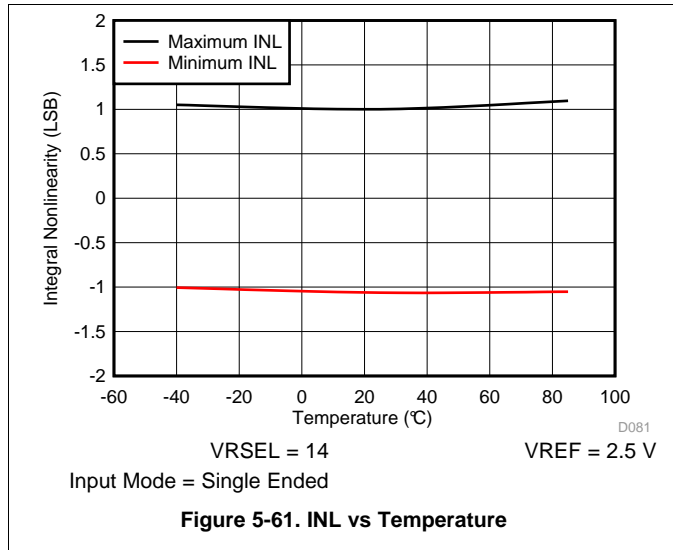

Figure 5-60. SFDR vs Temperature



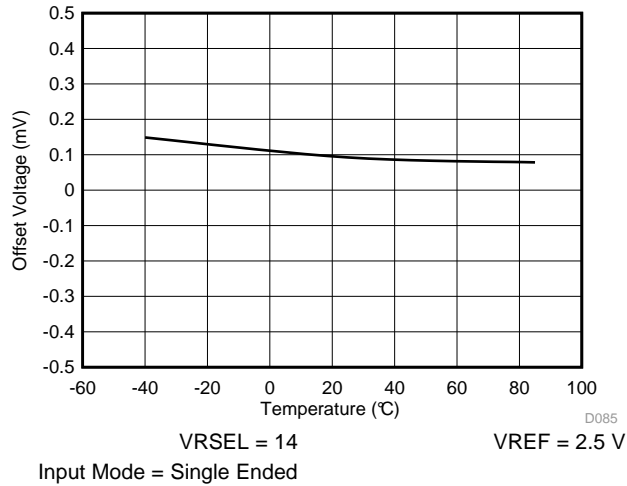

Figure 5-65. Offset Voltage vs Temperature

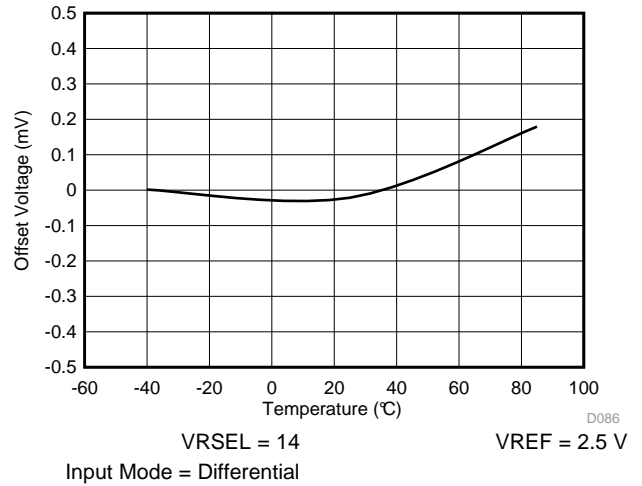

Figure 5-66. Offset Voltage vs Temperature

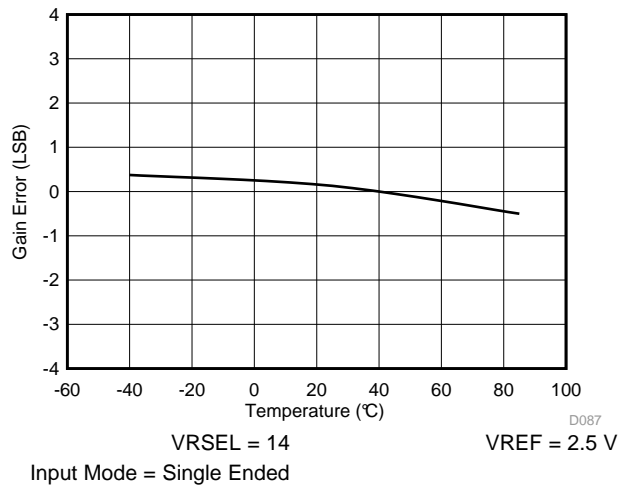

Figure 5-67. Gain Error vs Temperature

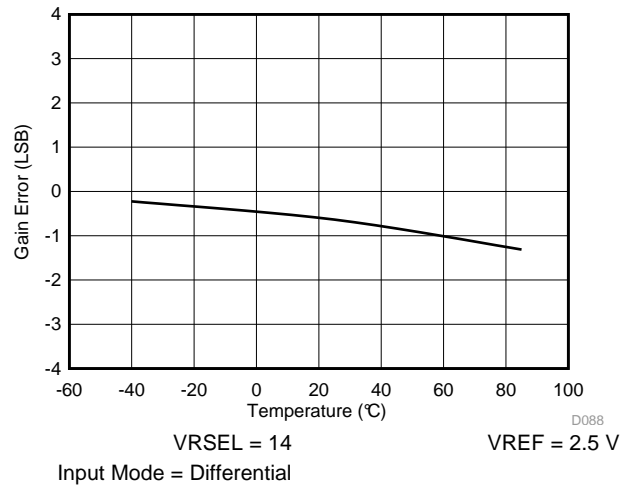

Figure 5-68. Gain Error vs Temperature

5.26.8 REF_A

Table 5-35 lists the characteristics of the REF_A built-in reference.

Table 5-35. REF_A, Built-In Reference (LDO Operation)

over recommended ranges of supply voltage and operating free-air temperature (unless otherwise noted)

PARAMETER	TEST CONDITIONS	V _{CC}	MIN	TYP	MAX	UNIT
V _{REF+}	Positive built-in reference voltage output	REFVSEL = {0} for 1.2 V, REFON = 1	1.62 V	1.2	±1%	V
		REFVSEL = {1} for 1.45 V, REFON = 1	1.75 V	1.45	±1%	
		REFVSEL = {3} for 2.5 V, REFON = 1	2.8 V	2.5	±1%	
AV _{CC(min)}	AV _{CC} minimum voltage, Positive built-in reference active	REFVSEL = {0} for 1.2 V		1.62		V
		REFVSEL = {1} for 1.45 V		1.75		
		REFVSEL = {3} for 2.5 V		2.8		
I _{REF+}	Operating supply current into AV _{CC} terminal ⁽¹⁾	REFON = 1	3 V	15	20	μA
I _{O(VREF+)}	VREF maximum load current, VREF+ terminal	REFVSEL = {0, 1, 3}, AV _{CC} = AV _{CC(min)} for each reference level, REFON = REFOUT = 1		-1000	+10	μA
I _{L(VREF+)}	Load-current regulation, VREF+ terminal	REFVSEL = {0, 1, 3}, I _(VREF+) = +10 μA or -1000 μA, AV _{CC} = AV _{CC(min)} for each reference level, REFON = REFOUT = 1			2500	μV/mA
C _{VREF±}	Capacitance at VREF+, VREF- terminals	REFON = REFOUT = 1		0	100	pF
PSRR _{DC} REFOUT0	Power supply rejection ratio (DC) after ADC buffer	AV _{CC} = AV _{CC(min)} for each reference level, REFVSEL = {0, 1, 3}, REFON = 1, REFOUT = 0		50	350	μV/V
PSRR _{DC} REFOUT1	Power supply rejection ratio (DC) after ADC buffer	AV _{CC} = AV _{CC(min)} for each reference level, REFVSEL = {0, 1, 3}, REFON = 1, REFOUT = 1		50	250	μV/V
PSRR _{AC} REFOUT0	Power supply rejection ratio (AC) after ADC buffer	AV _{CC} = AV _{CC(min)} for each reference level, dAV _{CC} = 0.1 V at 1 kHz, REFVSEL = {0, 1, 3}, REFON = 1, REFOUT = 0		2	10	mV/V
PSRR _{AC} REFOUT1	Power supply rejection ratio (AC) after ADC buffer	AV _{CC} = AV _{CC(min)} for each reference level, dAV _{CC} = 0.1 V at 1 kHz, REFVSEL = {0, 1, 3}, REFON = 1, REFOUT = 1		2	5	mV/V
TC _{REF+} ⁽²⁾	Temperature coefficient of built-in reference	REFVSEL = {0, 1, 3}, REFON = 1, T _A = -40°C to 85°C		25	60	ppm/°C
t _{SETTLE}	Settling time of reference voltage ⁽³⁾	AV _{CC} = AV _{CC(min)} to AV _{CC(max)} REFVSEL = {0, 1, 3}, REFON = 0 → 1		70	80	μs

(1) The internal reference current is supplied from the AV_{CC} terminal.

(2) Calculated using the box method: (MAX(-40°C to 85°C) – MIN(-40°C to 85°C)) / MIN(-40°C to 85°C)/(85°C – (-40°C)).

(3) The condition is that the error in a ADC conversion started after t_{SETTLE} is less than ±0.5 LSB.

5.26.9 Comparator_E

Table 5-36 lists the characteristics of the comparator.

Table 5-36. Comparator_E

over recommended ranges of supply voltage and operating free-air temperature (unless otherwise noted)

PARAMETER	TEST CONDITIONS	V _{CC}	MIN	TYP	MAX	UNIT	
V _{CC}	Supply voltage		1.62		3.7	V	
I _{AVCC_COMP}	Comparator operating supply current into AVCC, excluding reference resistor ladder	CEPWRMD = 00, CEON = 1, CERSx = 00 (fast)	2.2 V, 3 V	10	15	μA	
		CEPWRMD = 01, CEON = 1, CERSx = 00 (medium)	2.2 V, 3 V	8	10		
		CEPWRMD = 10, CEON = 1, CERSx = 00 (slow), T _A = 30°C	2.2 V, 3 V		0.5		
		CEPWRMD = 10, CEON = 1, CERSx = 00 (slow), T _A = 85°C	2.2 V, 3 V		0.5		
I _{AVCC_REF}	Quiescent current of resistor ladder into AVCC, including REF_A module current	CEREFACC = 0, CEREFLEX = 01, CERSx = 10, REFON = 0, CEON = 0	2.2 V, 3 V	25	35	μA	
		CEREFACC = 1, CEREFLEX = 01, CERSx = 10, REFON = 0, CEON = 0	2.2 V, 3 V	10	15		
V _{REF}	Reference voltage level	CERSx = 11, CEREFLEX = 01, CEREFACC = 0	1.62 V	1.17	1.2	1.23	V
		CERSx = 11, CEREFLEX = 10, CEREFACC = 0	2.2 V	1.95	2.0	2.05	
		CERSx = 11, CEREFLEX = 11, CEREFACC = 0	2.7 V	2.40	2.5	2.60	
		CERSx = 11, CEREFLEX = 01, CEREFACC = 1	1.62 V	1.15	1.2	1.23	
		CERSx = 11, CEREFLEX = 10, CEREFACC = 1	2.2 V	1.92	2.0	2.05	
		CERSx = 11, CEREFLEX = 11, CEREFACC = 1	2.7 V	2.4	2.5	2.6	
V _{IC}	Common-mode input range		0		V _{CC} – 1	V	
V _{OFFSET}	Input offset voltage	CEPWRMD = 00		–10	+10	mV	
		CEPWRMD = 01		–20	+20		
		CEPWRMD = 10		–20	+20		
C _{IN}	Input capacitance	CEPWRMD = 00 or CEPWRMD = 01		8		pF	
		CEPWRMD = 10		8			
R _{SIN}	Series input resistance	On (switch closed)		2	4	kΩ	
		Off (switch open)		50		MΩ	
t _{PD}	Propagation delay, response time	CEPWRMD = 00, CEF = 0, Overdrive ≥ 20 mV		330	550	ns	
		CEPWRMD = 01, CEF = 0, Overdrive ≥ 20 mV		410	650		
		CEPWRMD = 10, CEF = 0, Overdrive ≥ 20 mV			30	μs	
t _{PD,filter}	Propagation delay with filter active	CEPWRMD = 00 or 01, CEF = 1, Overdrive ≥ 20 mV, CEFDLY = 00		0.6	0.9	μs	
		CEPWRMD = 00 or 01, CEF = 1, Overdrive ≥ 20 mV, CEFDLY = 01		1.1	1.6		
		CEPWRMD = 00 or 01, CEF = 1, Overdrive ≥ 20 mV, CEFDLY = 10		2	3		
		CEPWRMD = 00 or 01, CEF = 1, Overdrive ≥ 20 mV, CEFDLY = 11		4	6		

Table 5-36. Comparator_E (continued)

over recommended ranges of supply voltage and operating free-air temperature (unless otherwise noted)

PARAMETER	TEST CONDITIONS	V _{CC}	MIN	TYP	MAX	UNIT
t _{EN_CMP} Comparator enable time	CEON = 0 to 1, CEPWRMD = 00, VIN+, VIN- from pins, Overdrive ≥ 20 mV			0.8	1	μs
	CEON = 0 to 1, CEPWRMD = 01, VIN+, VIN- from pins, Overdrive ≥ 20 mV			0.9	1.2	
	CEON = 0 to 1, CEPWRMD = 10, VIN+, VIN- from pins, Overdrive ≥ 20 mV			15	25	
t _{EN_CMP_VREF} Comparator and reference ladder and reference voltage enable time	CEON = 0 to 1, CEPWRMD = 00, CEREF _{Lx} = 10, CERS _x = 11, REFON = 0, Overdrive ≥ 20 mV			90	120	μs
	CEON = 0 to 1, CEPWRMD = 01, CEREF _{Lx} = 10, CERS _x = 11, REFON = 0, Overdrive ≥ 20 mV			90	120	
	CEON = 0 to 1, CEPWRMD = 10, CEREF _{Lx} = 10, CERS _x = 11, REFON = 0, Overdrive ≥ 20 mV			90	120	
	CEON = 0 to 1, CEPWRMD = 00, CEREF _{Lx} = 10, CERS _x = 10, REFON = 0, CEREF ₀ = CEREF ₁ = 0x0F, Overdrive ≥ 20 mV			90	180	
	CEON = 0 to 1, CEPWRMD = 01, CEREF _{Lx} = 10, CERS _x = 10, REFON = 0, CEREF ₀ = CEREF ₁ = 0x0F, Overdrive ≥ 20 mV			90	180	
	CEON = 0 to 1, CEPWRMD = 10, CEREF _{Lx} = 10, CERS _x = 10, REFON = 0, CEREF ₀ = CEREF ₁ = 0x0F, Overdrive ≥ 20 mV			90	180	
t _{EN_CMP_RL} Comparator and reference ladder enable time	CEON = 0 to 1, CEPWRMD = 00, CEREF _{Lx} = 10, CERS _x = 10, REFON = 1, CEREF ₀ = CEREF ₁ = 0x0F, Overdrive ≥ 20 mV			1.5	2	μs
	CEON = 0 to 1, CEPWRMD = 01, CEREF _{Lx} = 10, CERS _x = 10, REFON = 1, CEREF ₀ = CEREF ₁ = 0x0F, Overdrive ≥ 20 mV			1.5	2	
	CEON = 0 to 1, CEPWRMD = 10, CEREF _{Lx} = 10, CERS _x = 10, REFON = 1, CEREF ₀ = CEREF ₁ = 0x0F, Overdrive ≥ 20 mV			15	25	
V _{CMP_REF} Reference voltage for a given tap	VIN = reference into resistor ladder, n = 0 to 31		VIN × (n + 0.9) / 32	VIN × (n + 1) / 32	VIN × (n + 1.1) / 32	V

5.26.10 LCD_F

Table 5-37 lists the operating conditions of the LCD controller.

Table 5-37. LCD Recommended Operating Conditions

over recommended ranges of supply voltage and operating free-air temperature (unless otherwise noted)

PARAMETER	TEST CONDITIONS	MIN	NOM	MAX	UNIT
V _{CC,LCD} Supply voltage range, internal or external biasing		2.4		3.7	V
f _{ACLK,in} ACLK input frequency range		10	32.768	128	kHz

Table 5-37. LCD Recommended Operating Conditions (continued)

over recommended ranges of supply voltage and operating free-air temperature (unless otherwise noted)

PARAMETER		TEST CONDITIONS	MIN	NOM	MAX	UNIT
f_{LCD}	LCD frequency range	$f_{FRAME} = 1/(2 \times mux) \times f_{LCD}$ with $mux = 1$ (static) to 8			1024	Hz
$f_{FRAME,4mux}$	LCD frame frequency range	$f_{FRAME,4mux} (MAX) = 1/(2 \times 4) \times f_{LCD} (MAX) = 1 / (2 \times 4) \times 1024$ Hz			128	Hz
$f_{FRAME,8mux}$	LCD frame frequency range	$f_{FRAME,8mux} (MAX) = 1/(2 \times 8) \times f_{LCD} (MAX) = 1/(2 \times 8) \times 1024$ Hz			64	Hz
C_{Panel}	Panel capacitance	$f_{LCD} = 1024$ Hz, all common lines equally loaded			10000	pF
$V_{R23,1/3bias}$	Analog input voltage at R23 with 1/3 biasing	LCDREXT = 1, LCDEXTBIAS = 1, LCD2B = 0	V_{R13}	$V_{R03} + 2/3 \times (V_{CC} - V_{R03})$	V_{CC}	V
$V_{R13,1/3bias}$	Analog input voltage at R13 with 1/3 biasing	LCDREXT = 1, LCDEXTBIAS = 1, LCD2B = 0	V_{R03}	$V_{R03} + 1/3 \times (V_{CC} - V_{R03})$	V_{R23}	V
$V_{R13,1/2bias}$	Analog input voltage at R13 with 1/2 biasing, 1-4 Mux modes	LCDREXT = 1, LCDEXTBIAS = 1, LCD2B = 1, LCDMXx(2) = 0	V_{R03}	$V_{R03} + 1/2 \times (V_{CC} - V_{R03})$	V_{CC}	V
$V_{R23,1/4bias}$	Analog input voltage at R23 with 1/4 biasing, 4-8 Mux modes	LCDREXT = 1, LCDEXTBIAS = 1, LCD2B = 1, LCDMXx(2) = 1	V_{R13}	$3/4 \times V_{CC}$	V_{CC}	V
$V_{R13,1/4bias}$	Analog input voltage at R13 with 1/4 biasing, 4-8 Mux modes	LCDREXT = 1, LCDEXTBIAS = 1, LCD2B = 1, LCDMXx(2) = 1	V_{R03}	$1/2 \times V_{CC}$	V_{R23}	V
$V_{R03,1/4bias}$	Analog input voltage at R03 with 1/4 biasing, 4-8 Mux modes	LCDREXT = 1, LCDEXTBIAS = 1, LCD2B = 1, LCDMXx(2) = 1	V_{SS}	$1/4 \times V_{CC}$	V_{R13}	V
$V_{R03,EXT}$	Analog input voltage at R03 in 1/2 and 1/3-bias modes	R0EXT = 1	V_{SS}		V_{CC}	V

Table 5-38 lists the electrical characteristics of the LCD controller.

Table 5-38. LCD Electrical Characteristics

over operating free-air temperature range (unless otherwise noted)

PARAMETER		TEST CONDITIONS	V_{CC}	MIN	NOM	MAX	UNIT
$R_{LCD,Seg}$	LCD driver output impedance, segment lines	$I_{LOAD} = \pm 10 \mu A$	2.4 V			10	k Ω
$R_{LCD,COM}$	LCD driver output impedance, common lines	$I_{LOAD} = \pm 10 \mu A$	2.4 V			10	k Ω

5.26.11 eUSCI

Table 5-39 lists the supported clock frequencies of the eUSCI in UART mode.

Table 5-39. eUSCI Clock Frequency (UART Mode)

PARAMETER		TEST CONDITIONS	V _{CORE}	V _{CC}	MIN	MAX	UNIT
f _{eUSCI}	eUSCI input clock frequency	Internal: SMCLK, External: UCLK, Duty cycle = 50% ±10%	1.2 V			12	MHz
			1.4 V			24	
f _{BITCLK}	BITCLK clock frequency (equals baud rate in MBaud)		1.2 V			5	MHz
			1.4 V			7	

Table 5-40 lists the characteristics of the eUSCI in UART mode.

Table 5-40. eUSCI Switching Characteristics (UART Mode)

over recommended ranges of supply voltage and operating free-air temperature (unless otherwise noted)

PARAMETER		TEST CONDITIONS	V _{CC}	MIN	TYP	MAX	UNIT
t _t	UART receive deglitch time ⁽¹⁾	UCGLIT _x = 0		5		20	ns
		UCGLIT _x = 1		20		60	
		UCGLIT _x = 2		30		100	
		UCGLIT _x = 3		50		150	

- (1) Pulses on the UART receive input (UCxRX) shorter than the UART receive deglitch time are suppressed. Thus the selected deglitch time can limit the maximum useable baud rate. To ensure that pulses are correctly recognized, their duration must exceed the maximum specification of the deglitch time.

Table 5-41 lists the supported clock frequencies of the eUSCI in SPI master mode.

Table 5-41. eUSCI Clock Frequency (SPI Master Mode)

PARAMETER		TEST CONDITIONS	V _{CC}	MIN	MAX	UNIT
f _{eUSCI}	eUSCI input clock frequency	SMCLK Duty cycle = 50% ±10%	V _{CORE} = 1.2 V		12	MHz
			V _{CORE} = 1.4 V		24	

Table 5-42 lists the characteristics of the eUSCI in SPI master mode.

Table 5-42. eUSCI Switching Characteristics (SPI Master Mode)

over recommended ranges of supply voltage and operating free-air temperature (unless otherwise noted)⁽¹⁾

PARAMETER		TEST CONDITIONS	V _{CORE}	V _{CC}	MIN	MAX	UNIT
t _{STE,LEAD}	STE lead time, STE active to clock	UCSTEM = 1, UCMODEx = 01 or 10			1		UCxCLK cycles
t _{STE,LAG}	STE lag time, Last clock to STE inactive	UCSTEM = 1, UCMODEx = 01 or 10			1		
t _{STE,ACC}	STE access time, STE active to SIMO data out	UCSTEM = 0, UCMODEx = 01 or 10		1.62 V		30	ns
				3.7 V		20	
t _{STE,DIS}	STE disable time, STE inactive to SIMO high impedance	UCSTEM = 0, UCMODEx = 01 or 10		1.62 V		20	ns
				3.7 V		15	
t _{SU,MI}	SOMI input data setup time		1.2 V	1.62 V		45	ns
			1.4 V	3.7 V		30	
t _{HD,MI}	SOMI input data hold time			1.62 V		0	ns
				3.7 V		0	
t _{VALID,MO}	SIMO output data valid time ⁽²⁾	UCLK edge to SIMO valid, C _L = 20 pF		1.62 V		14	ns
				3.7 V		7	
t _{HD,MO}	SIMO output data hold time ⁽³⁾	C _L = 20 pF		1.62 V		0	ns
				3.7 V		0	

(1) $f_{UCxCLK} = 1/2t_{LO/HI}$ with $t_{LO/HI} = \max(t_{VALID,MO(eUSCI)} + t_{SU,SI(Slave)}, t_{SU,MI(eUSCI)} + t_{VALID,SO(Slave)})$

For the slave parameters $t_{SU,SI(Slave)}$ and $t_{VALID,SO(Slave)}$, see the SPI parameters of the attached slave.

(2) Specifies the time to drive the next valid data to the SIMO output after the output changing UCLK clock edge. See the timing diagrams in Figure 5-69 and Figure 5-70.

(3) Specifies how long data on the SIMO output is valid after the output changing UCLK clock edge. Negative values indicate that the data on the SIMO output can become invalid before the output changing clock edge observed on UCLK. See the timing diagrams in Figure 5-69 and Figure 5-70.

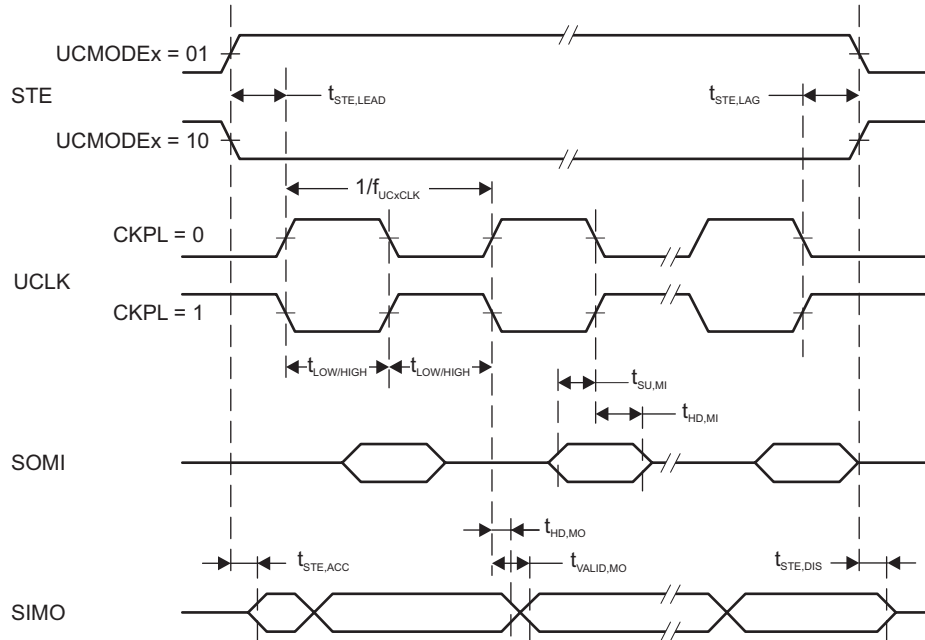

Figure 5-69. SPI Master Mode, CKPH = 0

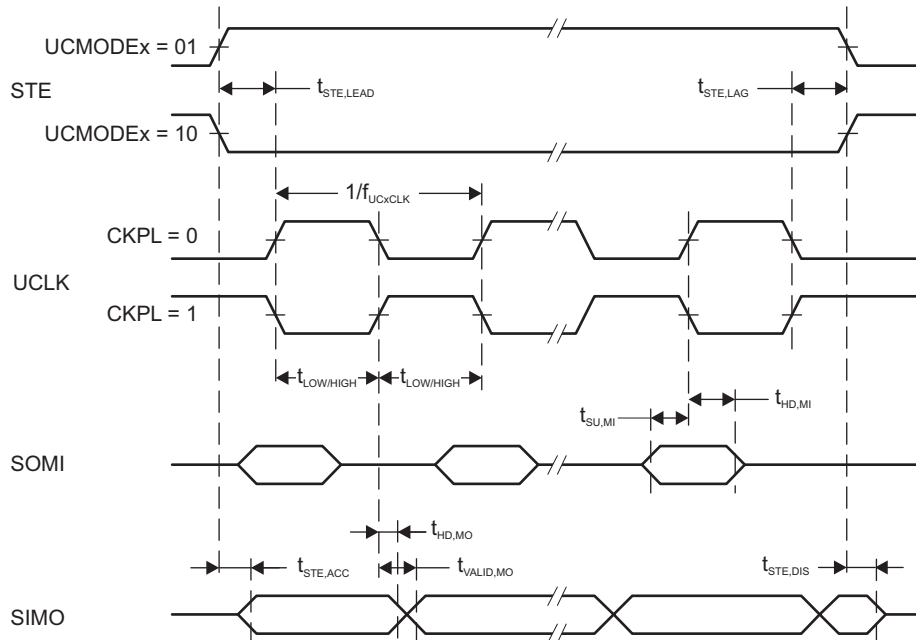

Figure 5-70. SPI Master Mode, CKPH = 1

Table 5-43 lists the characteristics of the eUSCI in SPI slave mode.

Table 5-43. eUSCI Switching Characteristics (SPI Slave Mode)

over recommended ranges of supply voltage and operating free-air temperature (unless otherwise noted)
(see Note ⁽¹⁾)

PARAMETER		TEST CONDITIONS	V _{CC}	MIN	MAX	UNIT
t _{STE,LEAD}	STE lead time, STE active to clock		1.62 V	45		ns
			3.7 V	20		
t _{STE,LAG}	STE lag time, Last clock to STE inactive		1.62 V	1		ns
			3.7 V	1		
t _{STE,ACC}	STE access time, STE active to SOMI data out		1.62 V		25	ns
			3.7 V		15	
t _{STE,DIS}	STE disable time, STE inactive to SOMI high impedance		1.62 V		18	ns
			3.7 V		14	
t _{SU,SI}	SIMO input data setup time		1.62 V	3		ns
			3.7 V	2		
t _{HD,SI}	SIMO input data hold time		1.62 V	0		ns
			3.7 V	0		
t _{VALID,SO}	SOMI output data valid time ⁽²⁾	UCLK edge to SOMI valid, C _L = 20 pF	1.62 V		35	ns
			3.7 V		18	
t _{HD,SO}	SOMI output data hold time ⁽³⁾	C _L = 20 pF	1.62 V	10		ns
			3.7 V	6		

- (1) $f_{UCxCLK} = 1/2t_{LO/HI}$ with $t_{LO/HI} \geq \max(t_{VALID,MO(Master)} + t_{SU,SI(eUSCI)}, t_{SU,MI(Master)} + t_{VALID,SO(eUSCI)})$
For the master parameters $t_{SU,MI(Master)}$ and $t_{VALID,MO(Master)}$, see the SPI parameters of the attached master.
- (2) Specifies the time to drive the next valid data to the SOMI output after the output changing UCLK clock edge. See the timing diagrams in [Figure 5-71](#) and [Figure 5-72](#).
- (3) Specifies how long data on the SOMI output is valid after the output changing UCLK clock edge. See the timing diagrams in [Figure 5-71](#) and [Figure 5-72](#).

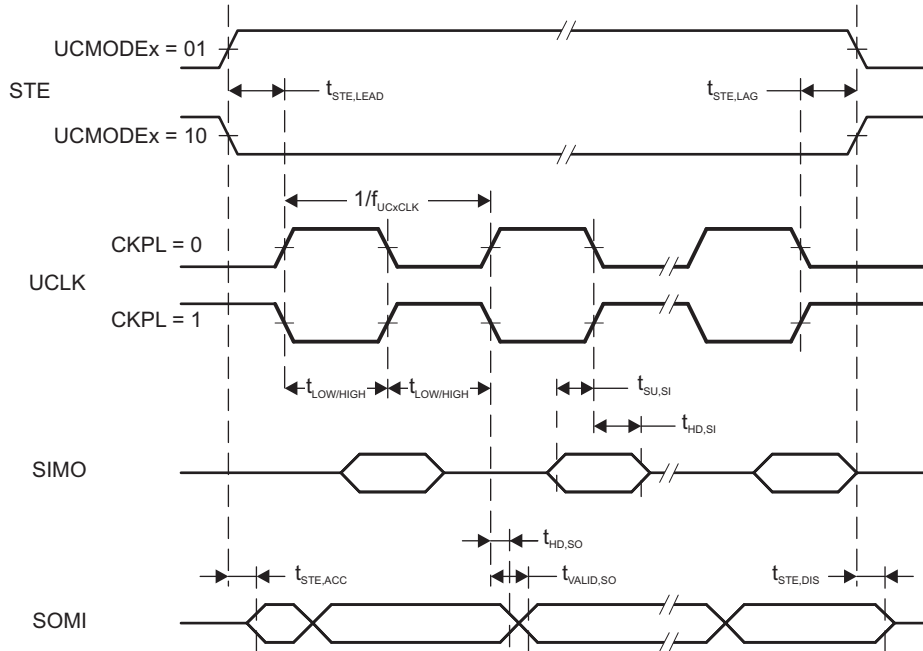

Figure 5-71. SPI Slave Mode, CKPH = 0

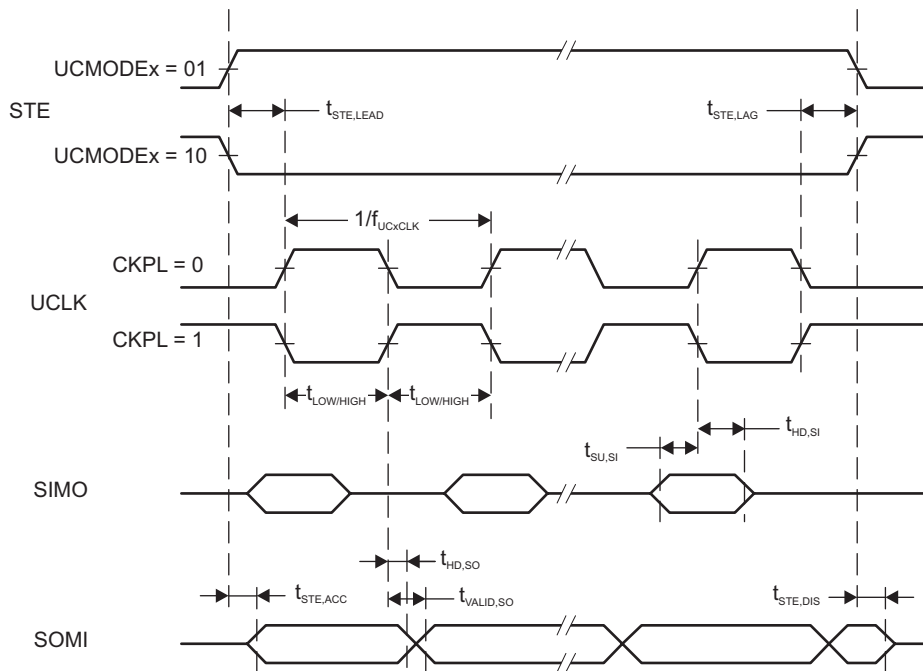

Figure 5-72. SPI Slave Mode, CKPH = 1

Table 5-44 lists the supported clock frequencies of the eUSCI in I²C mode.

Table 5-44. eUSCI Clock Frequency (I²C Mode)

PARAMETER	TEST CONDITIONS	V _{CORE}	V _{CC}	MIN	MAX	UNIT
f _{eUSCI}	eUSCI input clock frequency	Internal: SMCLK, External: UCLK, Duty cycle = 50% ±10%	1.2 V		12	MHz
			1.4 V		24	
f _{SCL}	SCL clock frequency				1	MHz

Table 5-45 lists the characteristics of the eUSCI in I²C mode.

Table 5-45. eUSCI Switching Characteristics (I²C Mode)

over recommended ranges of supply voltage and operating free-air temperature (unless otherwise noted) (see Figure 5-73)

PARAMETER	TEST CONDITIONS	MIN	TYP	MAX	UNIT
t _{HD,STA}	Hold time (repeated) START	f _{SCL} = 100 kHz	4.8		μs
		f _{SCL} = 400 kHz	1.21		
		f _{SCL} = 1 MHz	0.48		
t _{SU,STA}	Setup time for a repeated START	f _{SCL} = 100 kHz	4.9		μs
		f _{SCL} = 400 kHz	1.22		
		f _{SCL} = 1 MHz	0.47		
t _{HD,DAT}	Data hold time	f _{SCL} = 100 kHz	60		ns
		f _{SCL} = 400 kHz	60		
		f _{SCL} = 1 MHz	60		
t _{SU,DAT}	Data setup time	f _{SCL} = 100 kHz	4.7		μs
		f _{SCL} = 400 kHz	1.1		
		f _{SCL} = 1 MHz	0.35		
t _{SU,STO}	Setup time for STOP	f _{SCL} = 100 kHz	4.9		μs
		f _{SCL} = 400 kHz	1.25		
		f _{SCL} = 1 MHz	0.5		
t _{SP}	Pulse duration of spikes suppressed by input filter	UCGLIT _x = 0	50	120	ns
		UCGLIT _x = 1	25	60	
		UCGLIT _x = 2	10	35	
		UCGLIT _x = 3	5	20	
t _{TIMEOUT}	Clock low time-out	UCCLTO _x = 1		27	ms
		UCCLTO _x = 2		30	
		UCCLTO _x = 3		33	

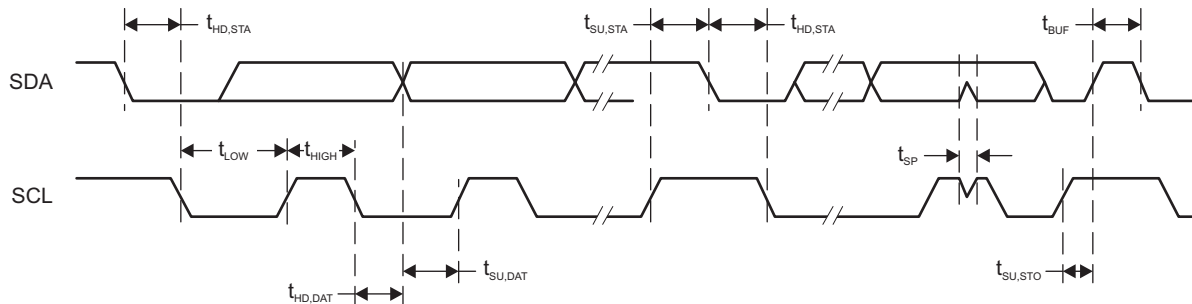

Figure 5-73. I²C Mode Timing

5.26.12 Timer_A

Table 5-46 lists the characteristics of Timer_A.

Table 5-46. Timer_A

over recommended ranges of supply voltage and operating free-air temperature (unless otherwise noted)

PARAMETER		TEST CONDITIONS	V _{CORE}	V _{CC}	MIN	MAX	UNIT
f _{TA}	Timer_A input clock frequency	Internal: SMCLK, External: TACLK, Duty cycle = 50% ±10%	1.2 V			12	MHz
			1.4 V			24	
t _{TA,cap}	Timer_A capture timing	All capture inputs, minimum pulse duration required for capture			20		ns

Table 5-47 lists the characteristics of Timer32.

Table 5-47. Timer32

over recommended ranges of supply voltage and operating free-air temperature (unless otherwise noted)

PARAMETER		TEST CONDITIONS	V _{CORE}	V _{CC}	MIN	MAX	UNIT
f _{T32}	Timer32 operating clock frequency ⁽¹⁾		1.2 V			24	MHz
			1.4 V			48	

(1) Timer32 operates on the same clock as the Cortex-M4 CPU.

5.26.13 Memories

Table 5-48 lists the general characteristics of the flash memory.

Table 5-48. Flash Memory

over recommended ranges of supply voltage and operating free-air temperature (unless otherwise noted)

PARAMETER		MIN	MAX	UNIT
DVCC _{PGMERS}	Supply voltage for program or erase	1.62	3.7	V
I _{PGM/ERS, PEAK}	Peak supply current from DVCC during program or erase		10	mA
N _{Endurance}	Program or erase endurance ⁽¹⁾	20000		cycles
t _{Retention}	Data retention duration	20		years
N _{PGM_TO_ERS}	Number of program operations supported between erases per sector		2000	

(1) Program or erase cycle for a bit is defined as the value of bit changing from 1 to 0 to 1.

Table 5-49 lists the characteristics of the flash operations using MSP432 peripheral driver libraries.

Table 5-49. Flash Operations Using MSP432 Peripheral Driver Libraries⁽¹⁾

over recommended ranges of supply voltage and operating free-air temperature (unless otherwise noted)

PARAMETER		TEST CONDITIONS	MIN	TYP	MAX	UNIT
t _{PGM_API, Word}	Program time for 32-bit data using ROM_FlashCtl_programMemory() API	V _{CORE} = 1.4 V, MCLK = 48 MHz		63	390	μs
t _{PGM_API, Sector}	Program time for 4kB data (one sector) using ROM_FlashCtl_programMemory() API	V _{CORE} = 1.4 V, MCLK = 48 MHz		5.7	80	ms
t _{ERS_API, Sector}	Sector erase time using ROM_FlashCtl_eraseSector() API	V _{CORE} = 1.4 V, MCLK = 48 MHz, Number of erase or program cycles <1000		9	309 ⁽²⁾	ms
		V _{CORE} = 1.4 V, MCLK = 48 MHz, Number of erase or program cycles >1000 and <20000		9	3035 ⁽²⁾	
t _{ERS_API, Mass-Erase}	Mass erase time using ROM_FlashCtl_performMassErase() API	V _{CORE} = 1.4 V, MCLK = 48 MHz, Number of erase or program cycles <1000, Devices with 2MB of flash memory		38	1292 ⁽³⁾	ms
		V _{CORE} = 1.4 V, MCLK = 48 MHz, Number of erase or program cycles <1000, Devices with 1MB of flash memory		24	816 ⁽³⁾	
		V _{CORE} = 1.4 V, MCLK = 48 MHz, Number of erase or program cycles <1000, Devices with 512KB of flash memory		17	578 ⁽³⁾	
I _{AVGPGM_API}	Average supply current from DVCC during program using ROM_FlashCtl_programMemory() API	V _{CORE} = 1.2 V, MCLK = 3 MHz		5	7	mA
I _{AVGERS_API}	Average supply current from DVCC during erase using ROM_FlashCtl_eraseSector() API	V _{CORE} = 1.2 V, MCLK = 3 MHz		2	3	mA

(1) MSP432 peripheral driver libraries executed from ROM.

(2) The maximum value is calculated by multiplying the typical value by N_{MAX_ERS} for the specific erase or program endurance.

(3) The maximum value is calculated by multiplying the typical value by N_{MAX_ERS} for the specific erase or program endurance and the total number of sectors in the flash main memory.

Table 5-50 lists the characteristics of the flash stand-alone operations.

Table 5-50. Flash Stand-Alone Operations

over recommended ranges of supply voltage and operating free-air temperature (unless otherwise noted)

PARAMETER		TEST CONDITIONS	MIN	TYP	MAX	UNIT
t _{PGM, Immediate}	Program time for one 32-bit data using immediate write mode	VER_PRE = 0, VER_PST = 1		52		μs
		VER_PRE = 1, VER_PST = 1		63		
t _{PGM, Full-word}	Program time for one 128-bit word using full word write mode	VER_PRE = 0, VER_PST = 1		49		μs
		VER_PRE = 1, VER_PST = 1		70		
t _{PGM, Burst}	Program time for 4x128-bit burst using burst write mode	AUTO_PRE = 0, AUTO_PST = 1		43		μs
		AUTO_PRE = 1, AUTO_PST = 1		64		
t _{ERS}	Time for sector erase or mass erase			9		ms
N _{MAX_PGM}	Maximum number of pulses to complete program operation				5	
N _{MAX_ERS}	Maximum number of pulses to complete erase operation	Number of erase or program cycles <1000			34	
		Number of erase or program cycles >1000 and <20000			334	

Table 5-51 lists the characteristics of the SRAM.

Table 5-51. SRAM

over recommended ranges of supply voltage and operating free-air temperature (unless otherwise noted)

PARAMETER		TEST CONDITIONS	MIN	TYP	MAX	UNIT
I _{SRAM_EN}	Current consumption of one SRAM bank when enabled	V _{CORE} = 1.2 V		0.55	20.5	μA
		V _{CORE} = 1.4 V		1.90	31	
I _{SRAM_RET}	Current consumption of one SRAM block under retention	V _{CORE} = 1.2 V		29	1700	nA
		V _{CORE} = 1.4 V		36	2300	
t _{SRAM_EN, one}	Time taken to enable one SRAM bank			8	10	μs
t _{SRAM_DIS, one}	Time taken to disable one SRAM bank			8	10	μs
t _{SRAM_EN, all}	Time taken to enable all SRAM banks except Bank 0			18	21	μs
t _{SRAM_DIS, all}	Time taken to disable all SRAM banks except Bank 0			8	10	μs

5.26.14 Emulation and Debug

Table 5-52 lists the characteristics of the JTAG interface.

Table 5-52. JTAG

over recommended ranges of supply voltage and operating free-air temperature (unless otherwise noted)

PARAMETER		MIN	TYP	MAX	UNIT
f_{TCK}	TCK clock frequency	0		10	MHz
t_{TCK}	TCK clock period	100			ns
t_{TCK_LOW}	TCK clock low time		$t_{TCK}/2$		ns
t_{TCK_HIGH}	TCK clock high time		$t_{TCK}/2$		ns
t_{TCK_RISE}	TCK rise time	0		10	ns
t_{TCK_FALL}	TCK fall time	0		10	ns
t_{TMS_SU}	TMS setup time to TCK rise	30			ns
t_{TMS_HLD}	TMS hold time from TCK rise	9			ns
t_{TDI_SU}	TDI setup time to TCK rise	20			ns
t_{TDI_HLD}	TDI hold time from TCK rise	7			ns
t_{TDO_ZDV}	TCK fall to data valid from high impedance		9	44	ns
t_{TDO_DV}	TCK fall to data valid from data valid		9	44	ns
t_{TDO_DVZ}	TCK fall to high impedance from data valid		8	38	ns

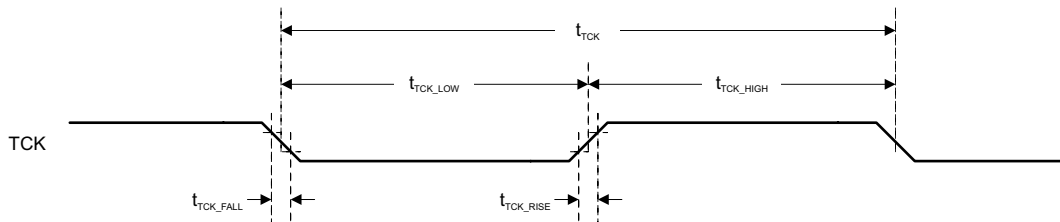

Figure 5-74. JTAG Test Clock Input Timing

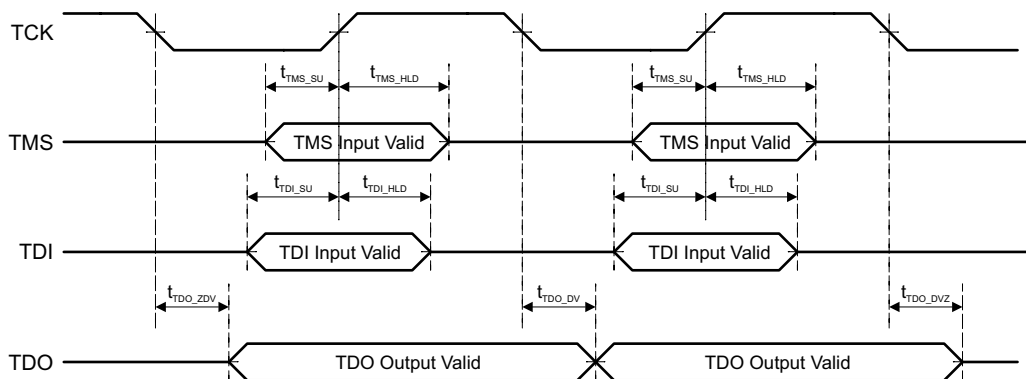

Figure 5-75. JTAG Test Access Port (TAP) Timing

6 Detailed Description

6.1 Overview

The MSP432P4x1x microcontroller is an ideal combination of the TI MSP430 low-power DNA, advanced mixed-signal features, and the processing capabilities of the Arm 32-bit Cortex-M4 RISC engine. The microcontrollers ship with bundled driver libraries and are compatible with standard components of the Arm ecosystem.

6.2 Processor and Execution Features

The Arm Cortex-M4 processor provides a high-performance low-cost platform that meets system requirements of minimal memory implementation, reduced pin count, and low power consumption, while delivering outstanding computational performance and exceptional system response to interrupts. The Thumb[®]-2 mixed 16- and 32-bit instruction set of the processor delivers the high performance that is expected of a 32-bit Arm core in a compact memory size usually associated with 8- and 16-bit devices (typically in the range of a few kilobytes of memory needed for microcontroller-class applications).

In MSP432P4x1x devices, the Cortex-M4 processor can run up to 48 MHz, delivering high performance for the targeted class of applications, while at the same time maintaining ultra-low active power consumption.

6.2.1 Floating-Point Unit (FPU)

The Cortex-M4 processor on MSP432P4x1x devices includes a tightly coupled FPU. The FPU is an IEEE 754 compliant single-precision floating-point module supporting add, subtract, multiply, divide, accumulate, and square-root operations. The FPU also provides conversion between fixed-point and floating-point data formats and floating-point constant instructions.

6.2.2 Memory Protection Unit (MPU)

The Cortex-M4 processor on MSP432P4x1x devices includes a tightly coupled MPU that supports up to eight protection regions. Applications can use the MPU to enforce memory privilege rules that isolate processes from each other or enforce memory access rules. These features are typically required for operating system handling purposes.

6.2.3 Nested Vectored Interrupt Controller (NVIC)

The NVIC supports up to 64 interrupts with eight levels of interrupt priority. The Cortex-M4 NVIC architecture allows for low latency, efficient interrupt and event handling, and seamless integration to device-level power-control strategies.

6.2.4 SysTick

The Cortex-M4 includes an integrated system timer, SysTick, which provides a simple, 24-bit, clear-on-write, decrementing, wrap-on-zero counter with a flexible control mechanism. The counter can be used in several different ways, and it is typically deployed either for use by the operating system or as a general-purpose alarm mechanism.

6.2.5 Debug and Trace Features

The Cortex-M4 processor implements a complete hardware debug solution and provides high system visibility of the processor and memory through either a traditional 4-pin JTAG port or a 2-pin Serial Wire Debug (SWD) port, which is ideal for microcontrollers and other small-package devices. The SWJ-DP interface combines the SWD and JTAG debug ports into one module, which allows a seamless switch between the 2-pin and 4-pin modes of operation, depending on application needs.

For system trace, the processor integrates an Instrumentation Trace Macrocell (ITM) alongside data watchpoints and a profiling unit. To enable simple and cost-effective profiling of the system trace events, a Serial Wire Viewer (SWV) can export a stream of software-generated messages, data trace, and profiling information through a single pin.

NOTE

For detailed specifications and information on the programmer's model for the Cortex-M4 CPU and the associated peripherals mentioned throughout [Section 6.2](#), see the appropriate reference manual at www.arm.com.

6.3 Memory Map

The device supports a 4-GB address space that is divided into eight 512MB zones (see [Figure 6-1](#)).

0xFFFF_FFFF	Debug/Trace Peripherals
0xE000_0000	
0xDFFF_FFFF	Unused
0xC000_0000	
0xBFFF_FFFF	Unused
0xA000_0000	
0x9FFF_FFFF	Unused
0x8000_0000	
0x7FFF_FFFF	Unused
0x6000_0000	
0x5FFF_FFFF	Peripherals
0x4000_0000	
0x3FFF_FFFF	SRAM
0x2000_0000	
0x1FFF_FFFF	Code
0x0000_0000	

Figure 6-1. Device Memory Zones

6.3.1 Code Zone Memory Map

The region from 0x0000_0000 to 0x1FFF_FFFF is defined as the Code zone, and is accessible through the ICODE and DCODE buses of the Cortex-M4 processor and through the system DMA. This region maps the flash, the ROM, and the internal SRAM (permitting optimal single-cycle execution from the SRAM).

[Figure 6-2](#) shows MSP432P4x1x1-specific memory map of the Code zone, as visible to the user code.

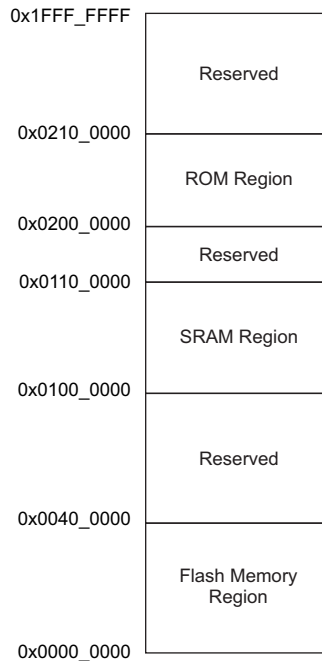

Figure 6-2. Code Zone Memory Map

6.3.1.1 Flash Memory Region

The 4MB region from 0x0000_0000 to 0x003F_FFFF is defined as the flash memory region. This region is further divided into different types of flash memory regions, which are explained in [Section 6.4.1](#).

6.3.1.2 SRAM Region

The 1MB region from 0x0100_0000 to 0x010F_FFFF is defined as the SRAM region. This region is also aliased in the *SRAM zone* of the device, thereby allowing efficient access to the SRAM, both for instruction fetches and data reads. See [Section 6.4.2](#) for more details.

6.3.1.3 ROM Region

The 1MB region from 0x0200_0000 to 0x020F_FFFF is defined as the ROM region. See [Section 6.4.4](#) for details about the ROM.

6.3.2 SRAM Zone Memory Map

The SRAM zone of the device lies in the address range of 0x2000_0000 to 0x3FFF_FFFF. This is further divided as shown in [Figure 6-3](#).

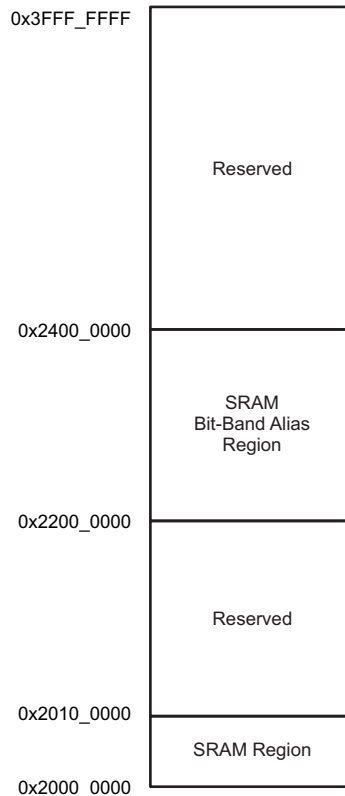

Figure 6-3. SRAM Zone Memory Map

6.3.2.1 SRAM Region

The 1MB region from 0x2000_0000 to 0x200F_FFFF is defined as the SRAM region. The SRAM accessible in this region is also aliased in the Code zone of the device, thereby allowing efficient access to the SRAM, both for instruction fetches and data reads. See [Section 6.4.2](#) for details about the SRAM.

6.3.2.2 SRAM Bit-Band Alias Region

The 32MB region from 0x2200_0000 to 0x23FF_FFFF forms the bit-band alias region for the 1MB SRAM region. Bit-banding is a feature of the Cortex-M4 processor and allows the application to set or clear individual bits throughout the SRAM space without using the pipeline bandwidth of the processor to carry out an exclusive read-modify-write sequence.

6.3.3 Peripheral Zone Memory Map

The Peripheral zone of the device is in the address range of 0x4000_0000 to 0x5FFF_FFFF. This is further divided as shown in [Figure 6-4](#).

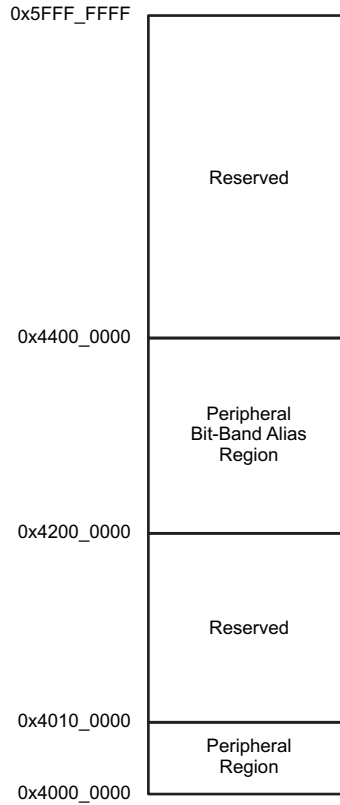

Figure 6-4. Peripheral Zone Memory Map

6.3.3.1 Peripheral Region

The 1MB region from 0x4000_0000 to 0x400F_FFFF is dedicated to the system and application control peripherals of the device. On MSP432P4x1x devices, a total of 128KB of this region is dedicated for peripherals, while the rest is reserved. Table 6-1 lists the peripheral allocation within this 128KB space.

NOTE

Peripherals that are marked as 16-bit can be accessed through byte or half-word size read or write only. Any 32-bit access to these peripherals results in a bus error response.

Table 6-1. Peripheral Address Offsets

ADDRESS RANGE	PERIPHERAL	TABLE	REMARKS
0x4000_0000 to 0x4000_03FF	Timer_A0	Table 6-2	16-bit peripheral
0x4000_0400 to 0x4000_07FF	Timer_A1	Table 6-3	16-bit peripheral
0x4000_0800 to 0x4000_0BFF	Timer_A2	Table 6-4	16-bit peripheral
0x4000_0C00 to 0x4000_0FFF	Timer_A3	Table 6-5	16-bit peripheral
0x4000_1000 to 0x4000_13FF	eUSCI_A0	Table 6-6	16-bit peripheral
0x4000_1400 to 0x4000_17FF	eUSCI_A1	Table 6-7	16-bit peripheral
0x4000_1800 to 0x4000_1BFF	eUSCI_A2	Table 6-8	16-bit peripheral
0x4000_1C00 to 0x4000_1FFF	eUSCI_A3	Table 6-9	16-bit peripheral
0x4000_2000 to 0x4000_23FF	eUSCI_B0	Table 6-10	16-bit peripheral
0x4000_2400 to 0x4000_27FF	eUSCI_B1	Table 6-11	16-bit peripheral
0x4000_2800 to 0x4000_2BFF	eUSCI_B2	Table 6-12	16-bit peripheral
0x4000_2C00 to 0x4000_2FFF	eUSCI_B3	Table 6-13	16-bit peripheral
0x4000_3000 to 0x4000_33FF	REF_A	Table 6-14	16-bit peripheral

Table 6-1. Peripheral Address Offsets (continued)

ADDRESS RANGE	PERIPHERAL	TABLE	REMARKS
0x4000_3400 to 0x4000_37FF	COMP_E0	Table 6-15	16-bit peripheral
0x4000_3800 to 0x4000_3BFF	COMP_E1	Table 6-16	16-bit peripheral
0x4000_3C00 to 0x4000_3FFF	AES256	Table 6-17	16-bit peripheral
0x4000_4000 to 0x4000_43FF	CRC32	Table 6-18	16-bit peripheral
0x4000_4400 to 0x4000_47FF	RTC_C	Table 6-19	16-bit peripheral
0x4000_4800 to 0x4000_4BFF	WDT_A	Table 6-20	16-bit peripheral
0x4000_4C00 to 0x4000_4FFF	Port Module	Table 6-21	16-bit peripheral
0x4000_5000 to 0x4000_53FF	Port Mapping Controller	Table 6-22	16-bit peripheral
0x4000_5400 to 0x4000_57FF	Capacitive Touch I/O 0	Table 6-23	16-bit peripheral
0x4000_5800 to 0x4000_5BFF	Capacitive Touch I/O 1	Table 6-24	16-bit peripheral
0x4000_5C00 to 0x4000_8FFF	Reserved		Read only, always reads 0h
0x4000_9000 to 0x4000_BFFF	Reserved		Read only, always reads 0h
0x4000_C000 to 0x4000_CFFF	Timer32	Table 6-25	
0x4000_D000 to 0x4000_D7FF	Reserved		Read only, always reads 0h
0x4000_D800 to 0x4000_DFFF	Utility SRAM		
0x4000_E000 to 0x4000_FFFF	DMA	Table 6-26	
0x4001_0000 to 0x4001_03FF	PCM	Table 6-27	
0x4001_0400 to 0x4001_07FF	CS	Table 6-28	
0x4001_0800 to 0x4001_0FFF	PSS	Table 6-29	
0x4001_1000 to 0x4001_17FF	FLCTL_A	Table 6-30	
0x4001_1800 to 0x4001_1BFF	Reserved		Read only, always reads 0h
0x4001_1C00 to 0x4001_1FFF	Reserved		Read only, always reads 0h
0x4001_2000 to 0x4001_23FF	Precision ADC	Table 6-31	
0x4001_2400 to 0x4001_27FF	LCD_F	Table 6-32	
0x4001_2800 to 0x4001_2BFF	Reserved		Read only, always reads 0h
0x4001_2C00 to 0x4001_FFFF	Reserved		Read only, always reads 0h

Table 6-2. Timer_A0 Registers (Base Address: 0x4000_0000)

REGISTER NAME	ACRONYM	OFFSET
Timer_A0 Control	TA0CTL	00h
Timer_A0 Capture/Compare Control 0	TA0CCTL0	02h
Timer_A0 Capture/Compare Control 1	TA0CCTL1	04h
Timer_A0 Capture/Compare Control 2	TA0CCTL2	06h
Timer_A0 Capture/Compare Control 3	TA0CCTL3	08h
Timer_A0 Capture/Compare Control 4	TA0CCTL4	0Ah
Timer_A0 Counter	TA0R	10h
Timer_A0 Capture/Compare 0	TA0CCR0	12h
Timer_A0 Capture/Compare 1	TA0CCR1	14h
Timer_A0 Capture/Compare 2	TA0CCR2	16h
Timer_A0 Capture/Compare 3	TA0CCR3	18h
Timer_A0 Capture/Compare 4	TA0CCR4	1Ah
Timer_A0 Interrupt Vector	TA0IV	2Eh
Timer_A0 Expansion 0	TA0EX0	20h

Table 6-3. Timer_A1 Registers (Base Address: 0x4000_0400)

REGISTER NAME	ACRONYM	OFFSET
Timer_A1 Control	TA1CTL	00h
Timer_A1 Capture/Compare Control 0	TA1CCTL0	02h
Timer_A1 Capture/Compare Control 1	TA1CCTL1	04h
Timer_A1 Capture/Compare Control 2	TA1CCTL2	06h
Timer_A1 Capture/Compare Control 3	TA1CCTL3	08h
Timer_A1 Capture/Compare Control 4	TA1CCTL4	0Ah
Timer_A1 Counter	TA1R	10h
Timer_A1 Capture/Compare 0	TA1CCR0	12h
Timer_A1 Capture/Compare 1	TA1CCR1	14h
Timer_A1 Capture/Compare 2	TA1CCR2	16h
Timer_A1 Capture/Compare 3	TA1CCR3	18h
Timer_A1 Capture/Compare 4	TA1CCR4	1Ah
Timer_A1 Interrupt Vector	TA1IV	2Eh
Timer_A1 Expansion 0	TA1EX0	20h

Table 6-4. Timer_A2 Registers (Base Address: 0x4000_0800)

REGISTER NAME	ACRONYM	OFFSET
Timer_A2 Control	TA2CTL	00h
Timer_A2 Capture/Compare Control 0	TA2CCTL0	02h
Timer_A2 Capture/Compare Control 1	TA2CCTL1	04h
Timer_A2 Capture/Compare Control 2	TA2CCTL2	06h
Timer_A2 Capture/Compare Control 3	TA2CCTL3	08h
Timer_A2 Capture/Compare Control 4	TA2CCTL4	0Ah
Timer_A2 Counter	TA2R	10h
Timer_A2 Capture/Compare 0	TA2CCR0	12h
Timer_A2 Capture/Compare 1	TA2CCR1	14h
Timer_A2 Capture/Compare 2	TA2CCR2	16h
Timer_A2 Capture/Compare 3	TA2CCR3	18h
Timer_A2 Capture/Compare 4	TA2CCR4	1Ah
Timer_A2 Interrupt Vector	TA2IV	2Eh
Timer_A2 Expansion 0	TA2EX0	20h

Table 6-5. Timer_A3 Registers (Base Address: 0x4000_0C00)

REGISTER NAME	ACRONYM	OFFSET
Timer_A3 Control	TA3CTL	00h
Timer_A3 Capture/Compare Control 0	TA3CCTL0	02h
Timer_A3 Capture/Compare Control 1	TA3CCTL1	04h
Timer_A3 Capture/Compare Control 2	TA3CCTL2	06h
Timer_A3 Capture/Compare Control 3	TA3CCTL3	08h
Timer_A3 Capture/Compare Control 4	TA3CCTL4	0Ah
Timer_A3 Counter	TA3R	10h
Timer_A3 Capture/Compare 0	TA3CCR0	12h
Timer_A3 Capture/Compare 1	TA3CCR1	14h
Timer_A3 Capture/Compare 2	TA3CCR2	16h
Timer_A3 Capture/Compare 3	TA3CCR3	18h
Timer_A3 Capture/Compare 4	TA3CCR4	1Ah
Timer_A3 Interrupt Vector	TA3IV	2Eh

Table 6-5. Timer_A3 Registers (Base Address: 0x4000_0C00) (continued)

REGISTER NAME	ACRONYM	OFFSET
Timer_A3 Expansion 0	TA3EX0	20h

Table 6-6. eUSCI_A0 Registers (Base Address: 0x4000_1000)

REGISTER NAME	ACRONYM	OFFSET
eUSCI_A0 Control Word 0	UCA0CTLW0	00h
eUSCI_A0 Control Word 1	UCA0CTLW1	02h
eUSCI_A0 Baud Rate Control	UCA0BRW	06h
eUSCI_A0 Modulation Control	UCA0MCTLW	08h
eUSCI_A0 Status	UCA0STATW	0Ah
eUSCI_A0 Receive Buffer	UCA0RXBUF	0Ch
eUSCI_A0 Transmit Buffer	UCA0TXBUF	0Eh
eUSCI_A0 Auto Baud Rate Control	UCA0ABCTL	10h
eUSCI_A0 IrDA Control	UCA0IRCTL	12h
eUSCI_A0 Interrupt Enable	UCA0IE	1Ah
eUSCI_A0 Interrupt Flag	UCA0IFG	1Ch
eUSCI_A0 Interrupt Vector	UCA0IV	1Eh

Table 6-7. eUSCI_A1 Registers (Base Address: 0x4000_1400)

REGISTER NAME	ACRONYM	OFFSET
eUSCI_A1 Control Word 0	UCA1CTLW0	00h
eUSCI_A1 Control Word 1	UCA1CTLW1	02h
eUSCI_A1 Baud Rate Control	UCA1BRW	06h
eUSCI_A1 Modulation Control	UCA1MCTLW	08h
eUSCI_A1 Status	UCA1STATW	0Ah
eUSCI_A1 Receive Buffer	UCA1RXBUF	0Ch
eUSCI_A1 Transmit Buffer	UCA1TXBUF	0Eh
eUSCI_A1 Auto Baud Rate Control	UCA1ABCTL	10h
eUSCI_A1 IrDA Control	UCA1IRCTL	12h
eUSCI_A1 Interrupt Enable	UCA1IE	1Ah
eUSCI_A1 Interrupt Flag	UCA1IFG	1Ch
eUSCI_A1 Interrupt Vector	UCA1IV	1Eh

Table 6-8. eUSCI_A2 Registers (Base Address: 0x4000_1800)

REGISTER NAME	ACRONYM	OFFSET
eUSCI_A2 Control Word 0	UCA2CTLW0	00h
eUSCI_A2 Control Word 1	UCA2CTLW1	02h
eUSCI_A2 Baud Rate Control	UCA2BRW	06h
eUSCI_A2 Modulation Control	UCA2MCTLW	08h
eUSCI_A2 Status	UCA2STATW	0Ah
eUSCI_A2 Receive Buffer	UCA2RXBUF	0Ch
eUSCI_A2 Transmit Buffer	UCA2TXBUF	0Eh
eUSCI_A2 Auto Baud Rate Control	UCA2ABCTL	10h
eUSCI_A2 IrDA Control	UCA2IRCTL	12h
eUSCI_A2 Interrupt Enable	UCA2IE	1Ah
eUSCI_A2 Interrupt Flag	UCA2IFG	1Ch
eUSCI_A2 Interrupt Vector	UCA2IV	1Eh

Table 6-9. eUSCI_A3 Registers (Base Address: 0x4000_1C00)

REGISTER NAME	ACRONYM	OFFSET
eUSCI_A3 Control Word 0	UCA3CTLW0	00h
eUSCI_A3 Control Word 1	UCA3CTLW1	02h
eUSCI_A3 Baud Rate Control	UCA3BRW	06h
eUSCI_A3 Modulation Control	UCA3MCTLW	08h
eUSCI_A3 Status	UCA3STATW	0Ah
eUSCI_A3 Receive Buffer	UCA3RXBUF	0Ch
eUSCI_A3 Transmit Buffer	UCA3TXBUF	0Eh
eUSCI_A3 Auto Baud Rate Control	UCA3ABCTL	10h
eUSCI_A3 IrDA Control	UCA3IRCTL	12h
eUSCI_A3 Interrupt Enable	UCA3IE	1Ah
eUSCI_A3 Interrupt Flag	UCA3IFG	1Ch
eUSCI_A3 Interrupt Vector	UCA3IV	1Eh

Table 6-10. eUSCI_B0 Registers (Base Address: 0x4000_2000)

REGISTER NAME	ACRONYM	OFFSET
eUSCI_B0 Control Word 0	UCB0CTLW0	00h
eUSCI_B0 Control Word 1	UCB0CTLW1	02h
eUSCI_B0 Bit Rate Control Word	UCB0BRW	06h
eUSCI_B0 Status Word	UCB0STATW	08h
eUSCI_B0 Byte Counter Threshold	UCB0TBCNT	0Ah
eUSCI_B0 Receive Buffer	UCB0RXBUF	0Ch
eUSCI_B0 Transmit Buffer	UCB0TXBUF	0Eh
eUSCI_B0 I2C Own Address 0	UCB0I2COA0	14h
eUSCI_B0 I2C Own Address 1	UCB0I2COA1	16h
eUSCI_B0 I2C Own Address 2	UCB0I2COA2	18h
eUSCI_B0 I2C Own Address 3	UCB0I2COA3	1Ah
eUSCI_B0 Received Address	UCB0ADDRX	1Ch
eUSCI_B0 Address Mask	UCB0ADDMASK	1Eh
eUSCI_B0 I2C Slave Address	UCB0I2CSA	20h
eUSCI_B0 Interrupt Enable	UCB0IE	2Ah
eUSCI_B0 Interrupt Flag	UCB0IFG	2Ch
eUSCI_B0 Interrupt Vector	UCB0IV	2Eh

Table 6-11. eUSCI_B1 Registers (Base Address: 0x4000_2400)

REGISTER NAME	ACRONYM	OFFSET
eUSCI_B1 Control Word 0	UCB1CTLW0	00h
eUSCI_B1 Control Word 1	UCB1CTLW1	02h
eUSCI_B1 Bit Rate Control Word	UCB1BRW	06h
eUSCI_B1 Status Word	UCB1STATW	08h
eUSCI_B1 Byte Counter Threshold	UCB1TBCNT	0Ah
eUSCI_B1 Receive Buffer	UCB1RXBUF	0Ch
eUSCI_B1 Transmit Buffer	UCB1TXBUF	0Eh
eUSCI_B1 I2C Own Address 0	UCB1I2COA0	14h
eUSCI_B1 I2C Own Address 1	UCB1I2COA1	16h
eUSCI_B1 I2C Own Address 2	UCB1I2COA2	18h
eUSCI_B1 I2C Own Address 3	UCB1I2COA3	1Ah
eUSCI_B1 Received Address	UCB1ADDRX	1Ch

Table 6-11. eUSCI_B1 Registers (Base Address: 0x4000_2400) (continued)

REGISTER NAME	ACRONYM	OFFSET
eUSCI_B1 Address Mask	UCB1ADDMASK	1Eh
eUSCI_B1 I2C Slave Address	UCB1I2CSA	20h
eUSCI_B1 Interrupt Enable	UCB1IE	2Ah
eUSCI_B1 Interrupt Flag	UCB1IFG	2Ch
eUSCI_B1 Interrupt Vector	UCB1IV	2Eh

Table 6-12. eUSCI_B2 Registers (Base Address: 0x4000_2800)

REGISTER NAME	ACRONYM	OFFSET
eUSCI_B2 Control Word 0	UCB2CTLW0	00h
eUSCI_B2 Control Word 1	UCB2CTLW1	02h
eUSCI_B2 Bit Rate Control Word	UCB2BRW	06h
eUSCI_B2 Status Word	UCB2STATW	08h
eUSCI_B2 Byte Counter Threshold	UCB2TBCNT	0Ah
eUSCI_B2 Receive Buffer	UCB2RXBUF	0Ch
eUSCI_B2 Transmit Buffer	UCB2TXBUF	0Eh
eUSCI_B2 I2C Own Address 0	UCB2I2COA0	14h
eUSCI_B2 I2C Own Address 1	UCB2I2COA1	16h
eUSCI_B2 I2C Own Address 2	UCB2I2COA2	18h
eUSCI_B2 I2C Own Address 3	UCB2I2COA3	1Ah
eUSCI_B2 Received Address	UCB2ADDRX	1Ch
eUSCI_B2 Address Mask	UCB2ADDMASK	1Eh
eUSCI_B2 I2C Slave Address	UCB2I2CSA	20h
eUSCI_B2 Interrupt Enable	UCB2IE	2Ah
eUSCI_B2 Interrupt Flag	UCB2IFG	2Ch
eUSCI_B2 Interrupt Vector	UCB2IV	2Eh

Table 6-13. eUSCI_B3 Registers (Base Address: 0x4000_2C00)

REGISTER NAME	ACRONYM	OFFSET
eUSCI_B3 Control Word 0	UCB3CTLW0	00h
eUSCI_B3 Control Word 1	UCB3CTLW1	02h
eUSCI_B3 Bit Rate Control Word	UCB3BRW	06h
eUSCI_B3 Status Word	UCB3STATW	08h
eUSCI_B3 Byte Counter Threshold	UCB3TBCNT	0Ah
eUSCI_B3 Receive Buffer	UCB3RXBUF	0Ch
eUSCI_B3 Transmit Buffer	UCB3TXBUF	0Eh
eUSCI_B3 I2C Own Address 0	UCB3I2COA0	14h
eUSCI_B3 I2C Own Address 1	UCB3I2COA1	16h
eUSCI_B3 I2C Own Address 2	UCB3I2COA2	18h
eUSCI_B3 I2C Own Address 3	UCB3I2COA3	1Ah
eUSCI_B3 Received Address	UCB3ADDRX	1Ch
eUSCI_B3 Address Mask	UCB3ADDMASK	1Eh
eUSCI_B3 I2C Slave Address	UCB3I2CSA	20h
eUSCI_B3 Interrupt Enable	UCB3IE	2Ah
eUSCI_B3 Interrupt Flag	UCB3IFG	2Ch
eUSCI_B3 Interrupt Vector	UCB3IV	2Eh

Table 6-14. REF_A Registers (Base Address: 0x4000_3000)

REGISTER NAME	ACRONYM	OFFSET
REF_A Control 0	REFCTL0	00h

Table 6-15. COMP_E0 Registers (Base Address: 0x4000_3400)

REGISTER NAME	ACRONYM	OFFSET
Comparator_E0 Control 0	CE0CTL0	00h
Comparator_E0 Control 1	CE0CTL1	02h
Comparator_E0 Control 2	CE0CTL2	04h
Comparator_E0 Control 3	CE0CTL3	06h
Comparator_E0 Interrupt	CE0INT	0Ch
Comparator_E0 Interrupt Vector Word	CE0IV	0Eh

Table 6-16. COMP_E1 Registers (Base Address: 0x4000_3800)

REGISTER NAME	ACRONYM	OFFSET
Comparator_E1 Control 0	CE1CTL0	00h
Comparator_E1 Control 1	CE1CTL1	02h
Comparator_E1 Control 2	CE1CTL2	04h
Comparator_E1 Control 3	CE1CTL3	06h
Comparator_E1 Interrupt	CE1INT	0Ch
Comparator_E1 Interrupt Vector Word	CE1IV	0Eh

Table 6-17. AES256 Registers (Base Address: 0x4000_3C00)

REGISTER NAME	ACRONYM	OFFSET
AES Accelerator Control 0	AESACTL0	00h
AES Accelerator Control 1	AESACTL1	02h
AES Accelerator Status	AESASTAT	04h
AES Accelerator Key	AESAKEY	06h
AES Accelerator Data In	AESADIN	08h
AES Accelerator Data Out	AESADOUT	0Ah
AES Accelerator XORed Data In	AESAXDIN	0Ch
AES Accelerator XORed Data In (no trigger)	AESAXIN	0Eh

Table 6-18. CRC32 Registers (Base Address: 0x4000_4000)

REGISTER NAME	ACRONYM	OFFSET
CRC32 Data Input Low	CRC32DI	000h
CRC32 Data In Reverse Low	CRC32DIRB	004h
CRC32 Initialization and Result Low	CRC32NIRES_LO	008h
CRC32 Initialization and Result High	CRC32NIRES_HI	00Ah
CRC32 Result Reverse Low	CRC32RESR_LO	00Ch
CRC32 Result Reverse High	CRC32RESR_HI	00Eh
CRC16 Data Input Low	CRC16DI	010h
CRC16 Data In Reverse Low	CRC16DIRB	014h
CRC16 Initialization and Result	CRC16NIRES	018h
CRC16 Result Reverse	CRC16RESR	01Eh

Table 6-19. RTC_C Registers (Base Address: 0x4000_4400)

REGISTER NAME	ACRONYM	OFFSET
Real-Time Clock Control 0	RTCCTL0	00h
Real-Time Clock Control 1, 3	RTCCTL13	02h
Real-Time Clock Offset Calibration	RTCOCAL	04h
Real-Time Clock Temperature Compensation	RTCTCMP	06h
Real-Time Prescale Timer 0 Control	RTCPS0CTL	08h
Real-Time Prescale Timer 1 Control	RTCPS1CTL	0Ah
Real-Time Prescale Timer 0, 1 Counter	RTCPS	0Ch
Real Time Clock Interrupt Vector	RTCIV	0Eh
Real-Time Clock Seconds, Minutes	RTCTIM0	10h
Real-Time Clock Hour, Day of Week	RTCTIM1	12h
Real-Time Clock Date	RTCDATE	14h
Real-Time Clock Year	RTCYEAR	16h
Real-Time Clock Minutes, Hour Alarm	RTCAMINHR	18h
Real-Time Clock Day of Week, Day of Month Alarm	RTCADOWDAY	1Ah
Binary-to-BCD Conversion	RTCBIN2BCD	1Ch
BCD-to-Binary Conversion	RTCBCD2BIN	1Eh

Table 6-20. WDT_A Registers (Base Address: 0x4000_4800)

REGISTER NAME	ACRONYM	OFFSET
Watchdog Timer Control	WDTCTL	0Ch

Table 6-21. Port Registers (Base Address: 0x4000_4C00)

REGISTER NAME	ACRONYM	OFFSET
Port 1 Input	P1IN	000h
Port 2 Input	P2IN	001h
Port 1 Output	P1OUT	002h
Port 2 Output	P2OUT	003h
Port 1 Direction	P1DIR	004h
Port 2 Direction	P2DIR	005h
Port 1 Resistor Enable	P1REN	006h
Port 2 Resistor Enable	P2REN	007h
Port 2 Drive Strength	P2DS	009h
Port 1 Select 0	P1SEL0	00Ah
Port 2 Select 0	P2SEL0	00Bh
Port 1 Select 1	P1SEL1	00Ch
Port 2 Select 1	P2SEL1	00Dh
Port 1 Interrupt Vector	P1IV	00Eh
Port 1 Complement Selection	P1SELC	016h
Port 2 Complement Selection	P2SELC	017h
Port 1 Interrupt Edge Select	P1IES	018h
Port 2 Interrupt Edge Select	P2IES	019h
Port 1 Interrupt Enable	P1IE	01Ah
Port 2 Interrupt Enable	P2IE	01Bh
Port 1 Interrupt Flag	P1IFG	01Ch
Port 2 Interrupt Flag	P2IFG	01Dh
Port 2 Interrupt Vector	P2IV	01Eh
Port 3 Input	P3IN	020h

Table 6-21. Port Registers (Base Address: 0x4000_4C00) (continued)

REGISTER NAME	ACRONYM	OFFSET
Port 4 Input	P4IN	021h
Port 3 Output	P3OUT	022h
Port 4 Output	P4OUT	023h
Port 3 Direction	P3DIR	024h
Port 4 Direction	P4DIR	025h
Port 3 Resistor Enable	P3REN	026h
Port 4 Resistor Enable	P4REN	027h
Port 3 Select 0	P3SELO	02Ah
Port 4 Select 0	P4SELO	02Bh
Port 3 Select 1	P3SEL1	02Ch
Port 4 Select 1	P4SEL1	02Dh
Port 3 Interrupt Vector	P3IV	02Eh
Port 3 Complement Selection	P3SELC	036h
Port 4 Complement Selection	P4SELC	037h
Port 3 Interrupt Edge Select	P3IES	038h
Port 4 Interrupt Edge Select	P4IES	039h
Port 3 Interrupt Enable	P3IE	03Ah
Port 4 Interrupt Enable	P4IE	03Bh
Port 3 Interrupt Flag	P3IFG	03Ch
Port 4 Interrupt Flag	P4IFG	03Dh
Port 4 Interrupt Vector	P4IV	03Eh
Port 5 Input	P5IN	040h
Port 6 Input	P6IN	041h
Port 5 Output	P5OUT	042h
Port 6 Output	P6OUT	043h
Port 5 Direction	P5DIR	044h
Port 6 Direction	P6DIR	045h
Port 5 Resistor Enable	P5REN	046h
Port 6 Resistor Enable	P6REN	047h
Port 5 Select 0	P5SELO	04Ah
Port 6 Select 0	P6SELO	04Bh
Port 5 Select 1	P5SEL1	04Ch
Port 6 Select 1	P6SEL1	04Dh
Port 5 Interrupt Vector	P5IV	04Eh
Port 5 Complement Selection	P5SELC	056h
Port 6 Complement Selection	P6SELC	057h
Port 5 Interrupt Edge Select	P5IES	058h
Port 6 Interrupt Edge Select	P6IES	059h
Port 5 Interrupt Enable	P5IE	05Ah
Port 6 Interrupt Enable	P6IE	05Bh
Port 5 Interrupt Flag	P5IFG	05Ch
Port 6 Interrupt Flag	P6IFG	05Dh
Port 6 Interrupt Vector	P6IV	05Eh
Port 7 Input	P7IN	060h
Port 8 Input	P8IN	061h
Port 7 Output	P7OUT	062h
Port 8 Output	P8OUT	063h

Table 6-21. Port Registers (Base Address: 0x4000_4C00) (continued)

REGISTER NAME	ACRONYM	OFFSET
Port 7 Direction	P7DIR	064h
Port 8 Direction	P8DIR	065h
Port 7 Resistor Enable	P7REN	066h
Port 8 Resistor Enable	P8REN	067h
Port 7 Select 0	P7SEL0	06Ah
Port 8 Select 0	P8SEL0	06Bh
Port 7 Select 1	P7SEL1	06Ch
Port 8 Select 1	P8SEL1	06Dh
Port 7 Complement Selection	P7SELC	076h
Port 8 Complement Selection	P8SELC	077h
Port 9 Input	P9IN	080h
Port 10 Input	P10IN	081h
Port 9 Output	P9OUT	082h
Port 10 Output	P10OUT	083h
Port 9 Direction	P9DIR	084h
Port 10 Direction	P10DIR	085h
Port 9 Resistor Enable	P9REN	086h
Port 10 Resistor Enable	P10REN	087h
Port 9 Select 0	P9SEL0	08Ah
Port 10 Select 0	P10SEL0	08Bh
Port 9 Select 1	P9SEL1	08Ch
Port 10 Select 1	P10SEL1	08Dh
Port 9 Complement Selection	P9SELC	096h
Port 10 Complement Selection	P10SELC	097h
Port J Input	PJIN	120h
Port J Output	PJOUT	122h
Port J Direction	PJDIR	124h
Port J Resistor Enable	PJREN	126h
Port J Select 0	PJSEL0	12Ah
Port J Select 1	PJSEL1	12Ch
Port J Complement Select	PJSELC	136h

Table 6-22. PMAP Registers (Base Address: 0x4000_5000)

REGISTER NAME	ACRONYM	OFFSET
Port Mapping Key	PMPKEYID	00h
Port Mapping Control	PMPCTL	02h
Port Mapping P2.0	P2MAP0	10h
Port Mapping P2.1	P2MAP1	11h
Port Mapping P2.2	P2MAP2	12h
Port Mapping P2.3	P2MAP3	13h
Port Mapping P2.4	P2MAP4	14h
Port Mapping P2.5	P2MAP5	15h
Port Mapping P2.6	P2MAP6	16h
Port Mapping P2.7	P2MAP7	17h
Port Mapping P3.0	P3MAP0	18h
Port Mapping P3.1	P3MAP1	19h
Port Mapping P3.2	P3MAP2	1Ah

Table 6-22. PMAP Registers (Base Address: 0x4000_5000) (continued)

REGISTER NAME	ACRONYM	OFFSET
Port Mapping P3.3	P3MAP3	1Bh
Port Mapping P3.4	P3MAP4	1Ch
Port Mapping P3.5	P3MAP5	1Dh
Port Mapping P3.6	P3MAP6	1Eh
Port Mapping P3.7	P3MAP7	1Fh
Port Mapping P7.0	P7MAP0	38h
Port Mapping P7.1	P7MAP1	39h
Port Mapping P7.2	P7MAP2	3Ah
Port Mapping P7.3	P7MAP3	3Bh
Port Mapping P7.4	P7MAP4	3Ch
Port Mapping P7.5	P7MAP5	3Dh
Port Mapping P7.6	P7MAP6	3Eh
Port Mapping P7.7	P7MAP7	3Fh

Table 6-23. Capacitive Touch I/O 0 Registers (Base Address: 0x4000_5400)

REGISTER NAME	ACRONYM	OFFSET
Capacitive Touch I/O 0 Control	CAPTIO0CTL	0Eh

Table 6-24. Capacitive Touch I/O 1 Registers (Base Address: 0x4000_5800)

REGISTER NAME	ACRONYM	OFFSET
Capacitive Touch I/O 1 Control	CAPTIO1CTL	0Eh

Table 6-25. Timer32 Registers (Base Address: 0x4000_C000)

REGISTER NAME	ACRONYM	OFFSET
Timer 1 Load	T32LOAD1	00h
Timer 1 Current Value	T32VALUE1	04h
Timer 1 Timer Control	T32CONTROL1	08h
Timer 1 Interrupt Clear	T32INTCLR1	0Ch
Timer 1 Raw Interrupt Status	T32RIS1	10h
Timer 1 Interrupt Status	T32MIS1	14h
Timer 1 Background Load	T32BGLOAD1	18h
Timer 2 Load	T32LOAD2	20h
Timer 2 Current Value	T32VALUE2	24h
Timer 2 Timer Control	T32CONTROL2	28h
Timer 2 Interrupt Clear	T32INTCLR2	2Ch
Timer 2 Raw Interrupt Status	T32RIS2	30h
Timer 2 Interrupt Status	T32MIS2	34h
Timer 2 Background Load	T32BGLOAD2	38h

Table 6-26. DMA Registers (Base Address: 0x4000_E000)

REGISTER NAME	ACRONYM	OFFSET
Device Configuration Status	DMA_DEVICE_CFG	000h
Software Channel Trigger	DMA_SW_CHTRIG	004h
Channel 0 Source Configuration	DMA_CH0_SRCCFG	010h
Channel 1 Source Configuration	DMA_CH1_SRCCFG	014h
Channel 2 Source Configuration	DMA_CH2_SRCCFG	018h

Table 6-26. DMA Registers (Base Address: 0x4000_E000) (continued)

REGISTER NAME	ACRONYM	OFFSET
Channel 3 Source Configuration	DMA_CH3_SRCCFG	01Ch
Channel 4 Source Configuration	DMA_CH4_SRCCFG	020h
Channel 5 Source Configuration	DMA_CH5_SRCCFG	024h
Channel 6 Source Configuration	DMA_CH6_SRCCFG	028h
Channel 7 Source Configuration	DMA_CH7_SRCCFG	02Ch
Interrupt 1 Source Channel Configuration	DMA_INT1_SRCCFG	100h
Interrupt 2 Source Channel Configuration	DMA_INT2_SRCCFG	104h
Interrupt 3 Source Channel Configuration	DMA_INT3_SRCCFG	108h
Interrupt 0 Source Channel Flag	DMA_INT0_SRCFLG	110h
Interrupt 0 Source Channel Clear Flag	DMA_INT0_CLRFLG	114h
Status	DMA_STAT	1000h
Configuration	DMA_CFG	1004h
Channel Control Data Base Pointer	DMA_CTLBASE	1008h
Channel Alternate Control Data Base Pointer	DMA_ALTBASE	100Ch
Channel Wait on Request Status	DMA_WAITSTAT	1010h
Channel Software Request	DMA_SWREQ	1014h
Channel Useburst Set	DMA_USEBURSTSET	1018h
Channel Useburst Clear	DMA_USEBURSTCLR	101Ch
Channel Request Mask Set	DMA_REQMASKSET	1020h
Channel Request Mask Clear	DMA_REQMASKCLR	1024h
Channel Enable Set	DMA_ENASET	1028h
Channel Enable Clear	DMA_ENACLAR	102Ch
Channel Primary-Alternate Set	DMA_ALTSET	1030h
Channel Primary-Alternate Clear	DMA_ALTCLR	1034h
Channel Priority Set	DMA_PRIOSSET	1038h
Channel Priority Clear	DMA_PRIOCLR	103Ch
Bus Error Clear	DMA_ERRCLR	104Ch

Table 6-27. PCM Registers (Base Address: 0x4001_0000)

REGISTER NAME	ACRONYM	OFFSET
Control 0	PCMCTL0	00h
Control 1	PCMCTL1	04h
Interrupt Enable	PCMIE	08h
Interrupt Flag	PCMIFG	0Ch
Clear Interrupt Flag	PCMCLRIFG	10h

Table 6-28. CS Registers (Base Address: 0x4001_0400)

REGISTER NAME	ACRONYM	OFFSET
Key	CSKEY	00h
Control 0	CSCTL0	04h
Control 1	CSCTL1	08h
Control 2	CSCTL2	0Ch
Control 3	CSCTL3	10h
Clock Enable	CSCLKEN	30h
Status	CSSTAT	34h
Interrupt Enable	CSIE	40h
Interrupt Flag	CSIFG	48h

Table 6-28. CS Registers (Base Address: 0x4001_0400) (continued)

REGISTER NAME	ACRONYM	OFFSET
Clear Interrupt Flag	CSCLRIFG	50h
Set Interrupt Flag	CSSETIFG	58h
DCO External Resistor Calibration 0	CSDCOERCAL0	60h
DCO External Resistor Calibration 1	CSDCOERCAL1	64h

Table 6-29. PSS Registers (Base Address: 0x4001_0800)

REGISTER NAME	ACRONYM	OFFSET
Key	PSSKEY	00h
Control 0	PSSCTL0	04h
Interrupt Enable	PSSIE	34h
Interrupt Flag	PSSIFG	38h
Clear Interrupt Flag	PSSCLRIFG	3Ch

Table 6-30. FLCTL_A Registers (Base Address: 0x4001_1000)

REGISTER NAME	ACRONYM	OFFSET
Power Status	FLCTL_POWER_STAT	000h
Bank 0 Read Control	FLCTL_BANK0_RDCTL	010h
Bank 1 Read Control	FLCTL_BANK1_RDCTL	014h
Read Burst/Compare Control and Status	FLCTL_RDBRST_CTLSTAT	020h
Read Burst/Compare Start Address	FLCTL_RDBRST_STARTADDR	024h
Read Burst/Compare Length	FLCTL_RDBRST_LEN	028h
Read Burst/Compare Fail Address	FLCTL_RDBRST_FAILADDR	03Ch
Read Burst/Compare Fail Count	FLCTL_RDBRST_FAILCNT	040h
Program Control and Status	FLCTL_PRG_CTLSTAT	050h
Program Burst Control and Status	FLCTL_PRGBRST_CTLSTAT	054h
Program Burst Start Address	FLCTL_PRGBRST_STARTADDR	058h
Program Burst Data0 0	FLCTL_PRGBRST_DATA0_0	060h
Program Burst Data0 1	FLCTL_PRGBRST_DATA0_1	064h
Program Burst Data0 2	FLCTL_PRGBRST_DATA0_2	068h
Program Burst Data0 3	FLCTL_PRGBRST_DATA0_3	06Ch
Program Burst Data1 0	FLCTL_PRGBRST_DATA1_0	070h
Program Burst Data1 1	FLCTL_PRGBRST_DATA1_1	074h
Program Burst Data1 2	FLCTL_PRGBRST_DATA1_2	078h
Program Burst Data1 3	FLCTL_PRGBRST_DATA1_3	07Ch
Program Burst Data2 0	FLCTL_PRGBRST_DATA2_0	080h
Program Burst Data2 1	FLCTL_PRGBRST_DATA2_1	084h
Program Burst Data2 2	FLCTL_PRGBRST_DATA2_2	088h
Program Burst Data2 3	FLCTL_PRGBRST_DATA2_3	08Ch
Program Burst Data3 0	FLCTL_PRGBRST_DATA3_0	090h
Program Burst Data3 1	FLCTL_PRGBRST_DATA3_1	094h
Program Burst Data3 2	FLCTL_PRGBRST_DATA3_2	098h
Program Burst Data3 3	FLCTL_PRGBRST_DATA3_3	09Ch
Erase Control and Status	FLCTL_ERASE_CTLSTAT	0A0h
Erase Sector Address	FLCTL_ERASE_SECTADDR	0A4h
Information Memory Bank 0 Write/Erase Protection	FLCTL_BANK0_INFO_WEPROT	0B0h
Information Memory Bank 1 Write/Erase Protection	FLCTL_BANK1_INFO_WEPROT	0C0h
Benchmark Control and Status	FLCTL_BMRK_CTLSTAT	0D0h

Table 6-30. FLCTL_A Registers (Base Address: 0x4001_1000) (continued)

REGISTER NAME	ACRONYM	OFFSET
Benchmark Instruction Fetch Count	FLCTL_BMRK_IFETCH	0D4h
Benchmark Data Read Count	FLCTL_BMRK_DREAD	0D8h
Benchmark Count Compare	FLCTL_BMRK_CMP	0DCh
Interrupt Flag	FLCTL_IFG	0F0h
Interrupt Enable	FLCTL_IE	0F4h
Clear Interrupt Flag	FLCTL_CLRIFG	0F8h
Set Interrupt Flag	FLCTL_SETIFG	0FCh
Read Timing Control	FLCTL_READ_TIMCTL	100h
Read Margin Timing Control	FLCTL_READMARGIN_TIMCTL	104h
Program Verify Timing Control	FLCTL_PRGVER_TIMCTL	108h
Erase Verify Timing Control	FLCTL_ERSVER_TIMCTL	10Ch
Program Timing Control	FLCTL_PROGRAM_TIMCTL	114h
Erase Timing Control	FLCTL_ERASE_TIMCTL	118h
Mass Erase Timing Control	FLCTL_MASSERASE_TIMCTL	11Ch
Burst Program Timing Control	FLCTL_BURSTPRG_TIMCTL	120h
Main Memory Bank 0 Write/Erase Protection 0	FLCTL_BANK0_MAIN_WEPROT0	200h
Main Memory Bank 0 Write/Erase Protection 1	FLCTL_BANK0_MAIN_WEPROT1	204h
Main Memory Bank 0 Write/Erase Protection 2	FLCTL_BANK0_MAIN_WEPROT2	208h
Main Memory Bank 0 Write/Erase Protection 3	FLCTL_BANK0_MAIN_WEPROT3	20Ch
Main Memory Bank 0 Write/Erase Protection 4	FLCTL_BANK0_MAIN_WEPROT4	210h
Main Memory Bank 0 Write/Erase Protection 5	FLCTL_BANK0_MAIN_WEPROT5	214h
Main Memory Bank 0 Write/Erase Protection 6	FLCTL_BANK0_MAIN_WEPROT6	218h
Main Memory Bank 0 Write/Erase Protection 7	FLCTL_BANK0_MAIN_WEPROT7	21Ch
Main Memory Bank 1 Write/Erase Protection 0	FLCTL_BANK1_MAIN_WEPROT0	240h
Main Memory Bank 1 Write/Erase Protection 1	FLCTL_BANK1_MAIN_WEPROT1	244h
Main Memory Bank 1 Write/Erase Protection 2	FLCTL_BANK1_MAIN_WEPROT2	248h
Main Memory Bank 1 Write/Erase Protection 3	FLCTL_BANK1_MAIN_WEPROT3	24Ch
Main Memory Bank 1 Write/Erase Protection 4	FLCTL_BANK1_MAIN_WEPROT4	250h
Main Memory Bank 1 Write/Erase Protection 5	FLCTL_BANK1_MAIN_WEPROT5	254h
Main Memory Bank 1 Write/Erase Protection 6	FLCTL_BANK1_MAIN_WEPROT6	258h
Main Memory Bank 1 Write/Erase Protection 7	FLCTL_BANK1_MAIN_WEPROT7	25Ch

Table 6-31. Precision ADC Registers (Base Address: 0x4001_2000)

REGISTER NAME	ACRONYM	OFFSET
Control 0	ADC14CTL0	00h
Control 1	ADC14CTL1	04h
Window Comparator Low Threshold 0	ADC14LO0	08h
Window Comparator High Threshold 0	ADC14HI0	0Ch
Window Comparator Low Threshold 1	ADC14LO1	10h
Window Comparator High Threshold 1	ADC14HI1	14h
Memory Control 0	ADC14MCTL0	18h
Memory Control 1	ADC14MCTL1	1Ch
Memory Control 2	ADC14MCTL2	20h
Memory Control 3	ADC14MCTL3	24h
Memory Control 4	ADC14MCTL4	28h
Memory Control 5	ADC14MCTL5	2Ch
Memory Control 6	ADC14MCTL6	30h

Table 6-31. Precision ADC Registers (Base Address: 0x4001_2000) (continued)

REGISTER NAME	ACRONYM	OFFSET
Memory Control 7	ADC14MCTL7	34h
Memory Control 8	ADC14MCTL8	38h
Memory Control 9	ADC14MCTL9	3Ch
Memory Control 10	ADC14MCTL10	40h
Memory Control 11	ADC14MCTL11	44h
Memory Control 12	ADC14MCTL12	48h
Memory Control 13	ADC14MCTL13	4Ch
Memory Control 14	ADC14MCTL14	50h
Memory Control 15	ADC14MCTL15	54h
Memory Control 16	ADC14MCTL16	58h
Memory Control 17	ADC14MCTL17	5Ch
Memory Control 18	ADC14MCTL18	60h
Memory Control 19	ADC14MCTL19	64h
Memory Control 20	ADC14MCTL20	68h
Memory Control 21	ADC14MCTL21	6Ch
Memory Control 22	ADC14MCTL22	70h
Memory Control 23	ADC14MCTL23	74h
Memory Control 24	ADC14MCTL24	78h
Memory Control 25	ADC14MCTL25	7Ch
Memory Control 26	ADC14MCTL26	80h
Memory Control 27	ADC14MCTL27	84h
Memory Control 28	ADC14MCTL28	88h
Memory Control 29	ADC14MCTL29	8Ch
Memory Control 30	ADC14MCTL30	90h
Memory Control 31	ADC14MCTL31	94h
Memory 0	ADC14MEM0	98h
Memory 1	ADC14MEM1	9Ch
Memory 2	ADC14MEM2	A0h
Memory 3	ADC14MEM3	A4h
Memory 4	ADC14MEM4	A8h
Memory 5	ADC14MEM5	ACH
Memory 6	ADC14MEM6	B0h
Memory 7	ADC14MEM7	B4h
Memory 8	ADC14MEM8	B8h
Memory 9	ADC14MEM9	BCh
Memory 10	ADC14MEM10	C0h
Memory 11	ADC14MEM11	C4h
Memory 12	ADC14MEM12	C8h
Memory 13	ADC14MEM13	CCh
Memory 14	ADC14MEM14	D0h
Memory 15	ADC14MEM15	D4h
Memory 16	ADC14MEM16	D8h
Memory 17	ADC14MEM17	DCh
Memory 18	ADC14MEM18	E0h
Memory 19	ADC14MEM19	E4h
Memory 20	ADC14MEM20	E8h
Memory 21	ADC14MEM21	ECh

Table 6-31. Precision ADC Registers (Base Address: 0x4001_2000) (continued)

REGISTER NAME	ACRONYM	OFFSET
Memory 22	ADC14MEM22	F0h
Memory 23	ADC14MEM23	F4h
Memory 24	ADC14MEM24	F8h
Memory 25	ADC14MEM25	FCh
Memory 26	ADC14MEM26	100
Memory 27	ADC14MEM27	104
Memory 28	ADC14MEM28	108
Memory 29	ADC14MEM29	10C
Memory 30	ADC14MEM30	110h
Memory 31	ADC14MEM31	114h
Interrupt Enable 0	ADC14IER0	13Ch
Interrupt Enable 1	ADC14IER1	140h
Interrupt Flag 0	ADC14IFGR0	144h
Interrupt Flag 1	ADC14IFGR1	148h
Clear Interrupt Flag 0	ADC14CLRIFGR0	14Ch
Clear Interrupt Flag 1	ADC14CLRIFGR1	150h
Interrupt Vector	ADC14IV	154h

Table 6-32. LCD_F Registers (Base Address: 0x4001_2400)

REGISTER NAME	ACRONYM	OFFSET
Control	LCDCTL	00h
Blinking and memory control	LCDBMCTL	04h
Voltage control	LCDVCTL	08h
Port control 0	LCDPCTL0	0Ch
Port control 1	LCDPCTL1	10h
COM/SEG select register 0	LCDCSSEL0	14h
COM/SEG select register 1	LCDCSSEL1	18h
Animation Control Register	LCDANMCTL	1Ch
Interrupt enable register	LCDIE	110h
Interrupt flag register	LCDIFG	114h
Set interrupt flag register	LCDSETIFG	118h
Clear interrupt flag register	LCDCLRIFG	11Ch
Memory 0 (L0)	LCDM0	120h
Memory 1 (L1)	LCDM1	121h
Memory 2 (L2)	LCDM2	122h
Memory 3 (L3)	LCDM3	123h
Memory 4 (L4)	LCDM4	124h
Memory 5 (L5)	LCDM5	125h
Memory 6 (L6)	LCDM6	126h
Memory 7 (L7)	LCDM7	127h
Memory 8 (L8)	LCDM8	128h
Memory 9 (L9)	LCDM9	129h
Memory 10 (L10)	LCDM10	12Ah
Memory 11 (L11)	LCDM11	12Bh
Memory 12 (L12)	LCDM12	12Ch
Memory 13 (L13)	LCDM13	12Dh
Memory 14 (L14)	LCDM14	12Eh

Table 6-32. LCD_F Registers (Base Address: 0x4001_2400) (continued)

REGISTER NAME	ACRONYM	OFFSET
Memory 15 (L15)	LCDM15	12Fh
Memory 16 (L16)	LCDM16	130h
Memory 17 (L17)	LCDM17	131h
Memory 18 (L18)	LCDM18	132h
Memory 19 (L19)	LCDM19	133h
Memory 20 (L20)	LCDM20	134h
Memory 21 (L21)	LCDM21	135h
Memory 22 (L22)	LCDM22	136h
Memory 23 (L23)	LCDM23	137h
Memory 24 (L24)	LCDM24	138h
Memory 25 (L25)	LCDM25	139h
Memory 26 (L26)	LCDM26	13Ah
Memory 27 (L27)	LCDM27	13Bh
Memory 28 (L28)	LCDM28	13Ch
Memory 29 (L29)	LCDM29	13Dh
Memory 30 (L30)	LCDM30	13Eh
Memory 31 (L31)	LCDM31	13Fh
Memory 32 (L32)	LCDM32	140h
Memory 33 (L33)	LCDM33	141h
Memory 34 (L34)	LCDM34	142h
Memory 35 (L35)	LCDM35	143h
Memory 36 (L36)	LCDM36	144h
Memory 37 (L37)	LCDM37	145h
Memory 38 (L38)	LCDM38	146h
Memory 39 (L39)	LCDM39	147h
Memory 40 (L40)	LCDM40	148h
Memory 41 (L41)	LCDM41	149h
Memory 42 (L42)	LCDM42	14Ah
Memory 43 (L43)	LCDM43	14Bh
Memory 44 (L44)	LCDM44	14Ch
Memory 45 (L45)	LCDM45	14Dh
Memory 46 (L46)	LCDM46	14Eh
Memory 47 (L47)	LCDM47	14Fh
Blinking memory 0 (L0)	LCDBM0	160h
Blinking memory 1 (L1)	LCDBM1	161h
Blinking memory 2 (L2)	LCDBM2	162h
Blinking memory 3 (L3)	LCDBM3	163h
Blinking memory 4 (L4)	LCDBM4	164h
Blinking memory 5 (L5)	LCDBM5	165h
Blinking memory 6 (L6)	LCDBM6	166h
Blinking memory 7 (L7)	LCDBM7	167h
Blinking memory 8 (L8)	LCDBM8	168h
Blinking memory 9 (L9)	LCDBM9	169h
Blinking memory 10 (L10)	LCDBM10	16Ah
Blinking memory 11 (L11)	LCDBM11	16Bh
Blinking memory 12 (L12)	LCDBM12	16Ch
Blinking memory 13 (L13)	LCDBM13	16Dh

Table 6-32. LCD_F Registers (Base Address: 0x4001_2400) (continued)

REGISTER NAME	ACRONYM	OFFSET
Blinking memory 14 (L14)	LCDBM14	16Eh
Blinking memory 15 (L15)	LCDBM15	17Fh
Blinking memory 16 (L16)	LCDBM16	170h
Blinking memory 17 (L17)	LCDBM17	171h
Blinking memory 18 (L18)	LCDBM18	172h
Blinking memory 19 (L19)	LCDBM19	173h
Blinking memory 20 (L20)	LCDBM20	174h
Blinking memory 21 (L21)	LCDBM21	175h
Blinking memory 22 (L22)	LCDBM22	176h
Blinking memory 23 (L23)	LCDBM23	177h
Blinking memory 24 (L24)	LCDBM24	178h
Blinking memory 25 (L25)	LCDBM25	179h
Blinking memory 26 (L26)	LCDBM26	17Ah
Blinking memory 27 (L27)	LCDBM27	17Bh
Blinking memory 28 (L28)	LCDBM28	17Ch
Blinking memory 29 (L29)	LCDBM29	17Dh
Blinking memory 30 (L30)	LCDBM30	17Eh
Blinking memory 31 (L31)	LCDBM31	17Fh
Blinking memory 32 (L32)	LCDBM32	180h
Blinking memory 33 (L33)	LCDBM33	181h
Blinking memory 34 (L34)	LCDBM34	182h
Blinking memory 35 (L35)	LCDBM35	183h
Blinking memory 36 (L36)	LCDBM36	184h
Blinking memory 37 (L37)	LCDBM37	185h
Blinking memory 38 (L38)	LCDBM38	186h
Blinking memory 39 (L39)	LCDBM39	187h
Blinking memory 40 (L40)	LCDBM40	188h
Blinking memory 41 (L41)	LCDBM41	189h
Blinking memory 42 (L42)	LCDBM42	18Ah
Blinking memory 43 (L43)	LCDBM43	18Bh
Blinking memory 44 (L44)	LCDBM44	18Ch
Blinking memory 45 (L45)	LCDBM45	18Dh
Blinking memory 46 (L46)	LCDBM46	18Eh
Blinking memory 47 (L47)	LCDBM47	18Fh
Animation memory 0	LCDANM0	1A0h
Animation memory 1	LCDANM1	1A1h
Animation memory 2	LCDANM2	1A2h
Animation memory 3	LCDANM3	1A3h
Animation memory 4	LCDANM4	1A4h
Animation memory 5	LCDANM5	1A5h
Animation memory 6	LCDANM6	1A6h
Animation memory 7	LCDANM7	1A7h

6.3.3.2 Peripheral Bit Band Alias Region

The 32MB region from 0x4200_0000 to 0x43FF_FFFF forms the bit-band alias region for the 1MB Peripheral region. Bit-banding is a feature of the Cortex-M4 processor and allows the application to set/clear individual bits throughout the peripheral memory space without using the pipeline bandwidth of the processor to carry out an exclusive read-modify-write sequence.

NOTE

The restriction of accessing 16-bit peripherals only through byte or half-word accesses also applies to the corresponding bit-band region of these peripherals. In other words, writes to the bit-band alias region for these peripherals must be in the form of byte or half-word accesses only.

6.3.4 Debug and Trace Peripheral Zone

This zone maps the internal and external PPB regions of the Cortex-M4. The following peripherals are mapped to this zone:

- Core and System debug control registers (internal PPB)
- NVIC and other registers in the System Control space of the Cortex-M4 (internal PPB)
- FPB, DWT, ITM (internal PPB)
- TPIU, Debug ROM table (external PPB)
- Reset Controller (external PPB)
- System Controller (external PPB)

Table 6-33. Debug Zone Memory Map

ADDRESS RANGE	MODULE OR PERIPHERAL	REMARKS
0xE000_0000 to 0xE000_0FFF	ITM	Internal PPB
0xE000_1000 to 0xE000_1FFF	DWT	Internal PPB
0xE000_2000 to 0xE000_2FFF	FPB	Internal PPB
0xE000_3000 to 0xE000_DFFF	Reserved	Internal PPB
0xE000_E000 to 0xE000_EFFF	Cortex-M4 System Control Space	Internal PPB
0xE000_F000 to 0xE003_FFFF	Reserved	Internal PPB
0xE004_0000 to 0xE004_0FFF	TPIU	External PPB
0xE004_1000 to 0xE004_1FFF	Reserved	External PPB
0xE004_2000 to 0xE004_23FF	Reset Controller (see Table 6-34)	External PPB
0xE004_2400 to 0xE004_2FFF	Reserved	External PPB
0xE004_3000 to 0xE004_33FF	System Controller	External PPB
0xE004_3400 to 0xE004_3FFF	Reserved	External PPB
0xE004_4000 to 0xE004_43FF	System Controller	External PPB
0xE004_4400 to 0xE00F_EFFF	Reserved	External PPB
0xE00F_F000 to 0xE00F_FFFF	ROM Table (External PPB)	External PPB
0xE010_0000 to 0xFFFF_FFFF	Reserved	Vendor Space

NOTE

For the address maps of the Arm modules listed in [Table 6-33](#), see Cortex-M4 technical reference manual at www.arm.com.

Table 6-34. RSTCTL Registers

REGISTER NAME	ACRONYM	OFFSET
Reset Request	RSTCTL_RESET_REQ	000h
Hard Reset Status	RSTCTL_HARDRESET_STAT	004h
Hard Reset Status Clear	RSTCTL_HARDRESET_CLR	008h
Hard Reset Status Set	RSTCTL_HARDRESET_SET	00Ch
Soft Reset Status	RSTCTL_SOFTRESET_STAT	010h
Soft Reset Status Clear	RSTCTL_SOFTRESET_CLR	014h
Soft Reset Status Set	RSTCTL_SOFTRESET_SET	018h
PSS Reset Status	RSTCTL_PSSRESET_STAT	100h
PSS Reset Status Clear	RSTCTL_PSSRESET_CLR	104h
PCM Reset Status	RSTCTL_PCMRESET_STAT	108h
PCM Reset Status Clear	RSTCTL_PCMRESET_CLR	10Ch
Pin Reset Status	RSTCTL_PINRESET_STAT	110h
Pin Reset Status Clear	RSTCTL_PINRESET_CLR	114h

Table 6-34. RSTCTL Registers (continued)

REGISTER NAME	ACRONYM	OFFSET
Reboot Reset Status	RSTCTL_REBOOTRESET_STAT	118h
Reboot Reset Status Clear	RSTCTL_REBOOTRESET_CLR	11Ch
CS Reset Status	RSTCTL_CSRESET_STAT	120h
CS Reset Status Clear	RSTCTL_CSRESET_CLR	124h

Table 6-35. SYSCTL_A Registers

REGISTER NAME	ACRONYM	OFFSET
Reboot Control	SYS_REBOOT_CTL	0000h
NMI Control and Status	SYS_NMI_CTLSTAT	0004h
Watchdog Reset Control	SYS_WDTRESET_CTL	0008h
Peripheral Halt Control	SYS_PERIHALT_CTL	000Ch
SRAM Size	SYS_SRAM_SIZE	0010h
SRAM Number of Banks	SYS_SRAM_NUMBANKS	0014h
SRAM Number of Blocks	SYS_SRAM_NUMBLOCKS	0018h
Flash Main Memory Size	SYS_MAINFLASH_SIZE	0020h
Flash Information Memory Size	SYS_INFOFLASH_SIZE	0024h
Digital I/O Glitch Filter Control	SYS_DIO_GLTFLT_CTL	0030h
IP Protected Secure Zone Data Access Unlock	SYS_SECDATA_UNLOCK	0040h
SRAM Bank Enable Control 0	SYS_SRAM_BANKEN_CTL0	0050h
SRAM Block Retention Control 0	SYS_SRAM_BLKRET_CTL0	0070h
SRAM Status	SYS_SRAM_STAT	0090h
Master Unlock	SYS_MASTER_UNLOCK	1000h
Boot Override Request 0	SYS_BOOTOVER_REQ0	1004h
Boot Override Request 1	SYS_BOOTOVER_REQ1	1008h
Boot Override Acknowledge	SYS_BOOTOVER_ACK	100Ch
Reset Request	SYS_RESET_REQ	1010h
Reset Status and Override	SYS_RESET_STATOVER	1014h
System Status	SYS_SYSTEM_STAT	1020h

6.4 Memories on MSP432P4x1x

MSP432P4x1x devices include flash memory and SRAM for general-application purposes. In addition, the devices include a backup memory (a portion of total available SRAM) that is retained in low-power modes.

6.4.1 Flash Memory

MSP432P4x1x devices include a high-endurance low-power flash memory that supports up to a minimum of 20000 write or erase cycles. The flash memory is 128 bits wide, thereby enabling high code execution performance by virtue of each fetch returning up to four 32-bit instructions (or up to eight 16-bit instructions). The flash is further divided into two types of subregions: Main Memory and Information Memory.

From a physical perspective the flash memory comprises of two banks, with the main and information memory regions divided equally between the two banks. This permits an application to carry out a simultaneous read or execute operation from one bank while the other bank may be undergoing a program or erase operation.

The memory map of flash on MSP432P4x1x devices is shown in [Figure 6-5](#).

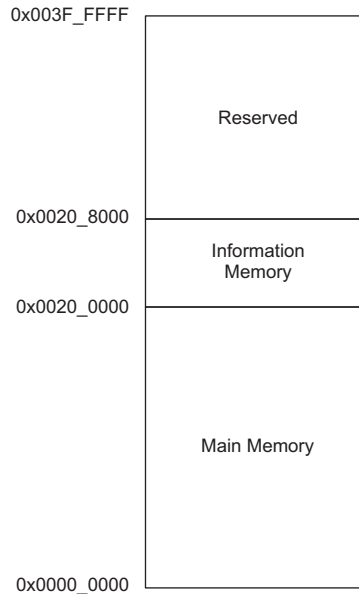

Figure 6-5. Flash Memory Map

6.4.1.1 Flash Main Memory (0x0000_0000 to 0x001F_FFFF)

The flash main memory on MSP432P4x1x devices can be up to 2MB. Flash main memory consists of up to 512 sectors of 4KB each, with a minimum erase granularity of 4KB (1 sector). The main memory can be viewed as two independent identical banks of up to 1MB each, allowing simultaneous read or execute from one bank while the other bank is undergoing a program or erase operation.

6.4.1.2 Flash Information Memory (0x0020_0000 to 0x0020_7FFF)

The flash information memory region is 32KB. Flash information memory consists of eight sectors of 4KB each, with a minimum erase granularity of 4KB (1 sector). The information memory can be viewed as two independent blocks of 16KB each, which allows read or execute from one block while the other block is undergoing a program or erase operation. [Table 6-36](#) describes different regions of flash information memory and the contents of each of the regions. The flash information memory region that contains the device descriptor (TLV) is factory configured for protection against write or erase operations. Flash information memory sectors that are empty are available for user application.

Table 6-36. Flash Information Memory Regions

REGION	ADDRESS RANGE	CONTENTS	WRITE AND ERASE PROTECTED?
Bank 0, Sector 0	0x0020_0000 to 0x0020_0FFF	Flash Boot-override Mailbox	No
Bank 0, Sector 1	0x0020_1000 to 0x0020_1FFF	Device Descriptor (TLV)	Yes
Bank 0, Sector 2	0x0020_2000 to 0x0020_2FFF	TI BSL	No
Bank 0, Sector 3	0x0020_3000 to 0x0020_3FFF	TI BSL	No
Bank 1, Sector 0	0x0020_4000 to 0x0020_4FFF	Empty	No
Bank 1, Sector 1	0x0020_5000 to 0x0020_5FFF	Empty	No
Bank 1, Sector 2	0x0020_6000 to 0x0020_6FFF	Empty	No
Bank 1, Sector 3	0x0020_7000 to 0x0020_7FFF	Empty	No

6.4.1.3 Flash Operation

The flash memory provides multiple read and program modes of operation that the application can deploy. Up to 128 bits (memory word width) can be programmed (set from 1 to 0) in a single program operation. Although the CPU data buses are 32 bits wide, the flash can buffer 128-bit write data before initiating flash programming, thereby making it more seamless and power efficient for software to program large blocks of data at a time. In addition, the flash memory also supports a burst write mode that takes less time when compared to programming words individually. See [Flash Memory](#) for information on timing parameters.

The flash main and information memory regions offer write/erase protection control at a sector granularity to enable software to optimize operations like mass erase while protecting certain regions of the flash. In low-power modes of operation, the flash memory is disabled and put in a power-down state to minimize leakage.

For details on the flash memory and its various modes of operation and configuration, see the *Flash Controller A (FLCTL_A)* chapter in the [MSP432P4xx SimpleLink™ Microcontrollers Technical Reference Manual](#).

NOTE

Depending on the CPU (MCLK) frequency and the active mode in use, the flash may need to be accessed with single/multiple wait states. Whenever there is a change required in the operating frequency, the application must ensure that the flash access wait states are configured correctly before the frequency change is effected. See the electrical specification for details on flash wait state requirements.

6.4.2 SRAM

MSP432P4x1x devices support up to 256KB of SRAM, with the rest of the 1MB SRAM region reserved. The SRAM is aliased in *both* Code and SRAM zones. This enables fast, single cycle execution of code from the SRAM, as the Cortex-M4 processor pipelines instruction fetches to memory zones other than the Code space. As with the flash memory, the SRAM can be powered down or placed in a low-leakage retention state in low-power modes of operation.

[Figure 6-6](#) shows the memory map of SRAM on MSP432P4x1x devices.

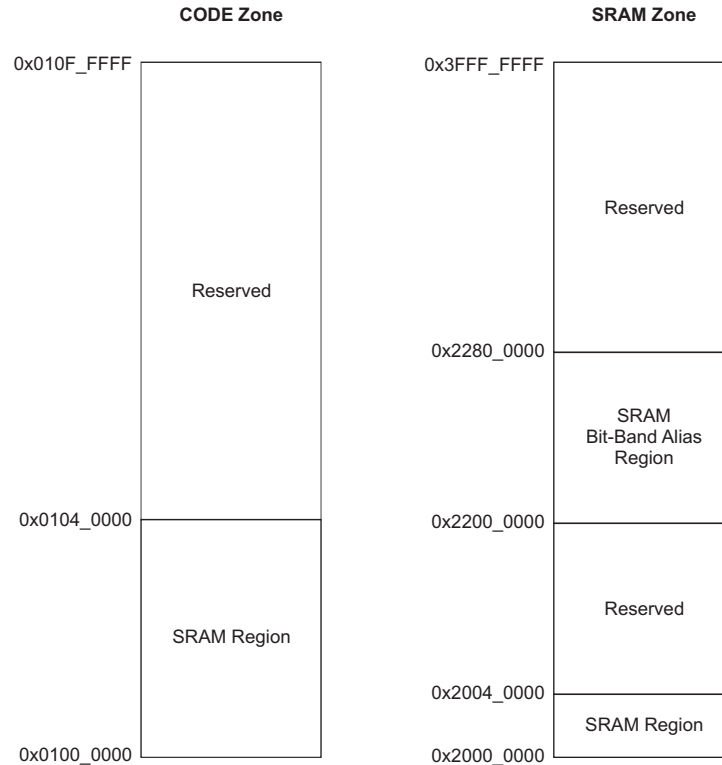

Figure 6-6. SRAM Map

6.4.2.1 SRAM Bank Enable Configuration

The application can optimize the power consumption of the SRAM. To enable this, the SRAM is divided into 64KB banks that can be individually powered down. Banks that are powered down remain powered down in both active and low-power modes of operation, thereby limiting any unnecessary inrush current when the device transitions between active and retention-based low-power modes. The application can also disable one (or more) banks for a certain stage in the processing and enable it for another stage.

When a particular bank is disabled, reads to its address space return 0h, and writes are discarded. To prevent holes in the memory map, if a particular bank is enabled, all the lower banks are also forced to be enabled. This ensures a contiguous memory map through the set of enabled banks instead of allowing a disabled bank to appear between enabled banks. For example:

- If there are four banks in the device, the valid combinations of the BNKxx_EN fields in the SYS_SRAM_BANKEN_CTL0 register are 0001, 0011, 0111, and 1111.
- Other combination of BNKxx_EN fields like 1011 are not valid, and the resultant bank configuration is automatically set to 1111.

Figure 6-7 shows valid and invalid combinations of the bank enable fields.

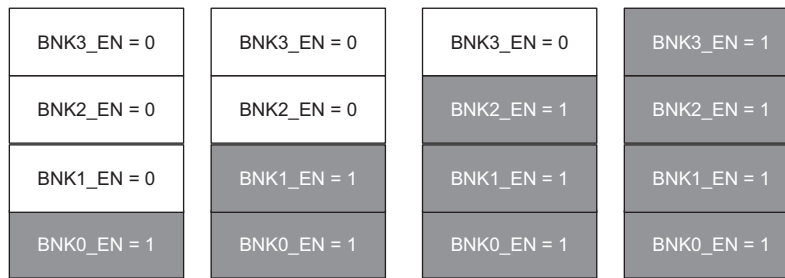

Valid SRAM bank enables for SRAM with 4 banks

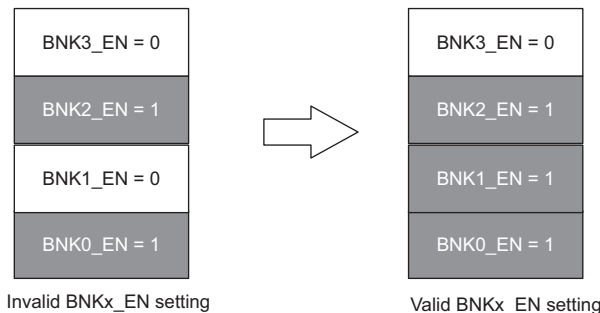

Conversion of invalid bank enables to valid setting

Figure 6-7. Configuring SRAM Bank Enables

Bank 0 of SRAM is always enabled and cannot be disabled. For all other banks, any enable or disable change results in the BNKEN_RDY bit of the SYS_SRAM_STAT register being set to 0 until the configuration change is effective. Any accesses to the SRAM is stalled during this time, and access resumes only after the SRAM banks are ready for read or write operations. This is handled transparently and does not require any code intervention. See SRAM characteristics in the electrical specification for the SRAM bank enable or disable latency.

6.4.2.2 SRAM Block Retention Configuration and Backup Memory

The application can optimize the leakage power consumption of the SRAM in LPM3 and LPM4 modes of operation. To enable this, each SRAM bank is further divided into 8KB blocks that can be individually configured for retention. Blocks that are enabled for retention retain their data through the LPM3 and LPM4 modes. The application can also retain a subset of the blocks in the enabled banks.

For example, the application may need 128KB of SRAM for its processing needs (two banks are kept enabled). However, of these two banks, only one 8KB block can contain critical data that must be retained in LPM3 or LPM4, while the rest are powered off completely to minimize power consumption.

Block 0 of SRAM Bank 0 is always retained and cannot be powered down. Therefore, it also operates as a possible backup memory in the LPM3, LPM4, and LPM3.5 modes of operation.

6.4.3 Utility SRAM

MSP432P4x1x devices support an additional 2KB of utility SRAM space in the peripheral memory map region. This space can be used by the application for storing any application related data (for example, DMA descriptors).

6.4.4 ROM

MSP432P4x1x devices support 32KB of ROM, with the rest of the 1MB region reserved (for future upgrades). The lower 2KB of the ROM is reserved for TI internal purposes and accesses to this space return an error response. The rest of the ROM is used for driver libraries.

NOTE

The entire ROM region returns an error response for write accesses. The lower 2KB of the ROM always returns an error response for any access.

6.5 DMA

MSP432P4x1x devices implement an 8-channel Arm μ DMA. This allows eight simultaneously active channels for data transfer between memory and peripherals without needing to use the bandwidth of the CPU (thereby reducing power by idling the CPU when there is no data processing required). In addition, the DMA remains active in multiple low-power modes of operation, allowing for a very low power state in which data can be transferred at low rates.

For maximum flexibility, up to eight DMA event sources can map to any of the eight channels. This is controlled through configuration registers in the DMA. In addition, the DMA can generate up to four interrupt requests (described in [Section 6.5.2](#)). For details regarding configuration of the DMA, see the DMA chapter in the [MSP432P4xx SimpleLink™ Microcontrollers Technical Reference Manual](#).

6.5.1 DMA Source Mapping

Each channel of the eight available channels has a control register that can select any of the device-level DMA sources as the final source for that corresponding channel. [Table 6-37](#) lists the sources available for mapping to each channel, based on the value of the Source Config Register (SRCCFG).

Table 6-37. DMA Sources

CHANNEL	SRCCFG							
	0	1	2	3	4	5	6	7
0	Reserved	eUSCI_A0 TX	eUSCI_B0 TX0	eUSCI_B3 TX1	eUSCI_B2 TX2	eUSCI_B1 TX3	TA0CCR0	AES256_Trigger0
1	Reserved	eUSCI_A0 RX	eUSCI_B0 RX0	eUSCI_B3 RX1	eUSCI_B2 RX2	eUSCI_B1 RX3	TA0CCR2	AES256_Trigger1
2	Reserved	eUSCI_A1 TX	eUSCI_B1 TX0	eUSCI_B0 TX1	eUSCI_B3 TX2	eUSCI_B2 TX3	TA1CCR0	AES256_Trigger2
3	Reserved	eUSCI_A1 RX	eUSCI_B1 RX0	eUSCI_B0 RX1	eUSCI_B3 RX2	eUSCI_B2 RX3	TA1CCR2	Reserved
4	Reserved	eUSCI_A2 TX	eUSCI_B2 TX0	eUSCI_B1 TX1	eUSCI_B0 TX2	eUSCI_B3 TX3	TA2CCR0	Reserved
5	Reserved	eUSCI_A2 RX	eUSCI_B2 RX0	eUSCI_B1 RX1	eUSCI_B0 RX2	eUSCI_B3 RX3	TA2CCR2	Reserved
6	Reserved	eUSCI_A3 TX	eUSCI_B3 TX0	eUSCI_B2 TX1	eUSCI_B1 TX2	eUSCI_B0 TX3	TA3CCR0	DMAE0 (External Pin)
7	Reserved	eUSCI_A3 RX	eUSCI_B3 RX0	eUSCI_B2 RX1	eUSCI_B1 RX2	eUSCI_B0 RX3	TA3CCR2	Precision ADC

NOTE

Any source marked as Reserved is unused. It may be used for software-controlled DMA tasks, but typically it is reserved for enhancement purposes on future devices.

6.5.2 DMA Completion Interrupts

In the case of the Arm μ DMA controller, it is usually the responsibility of software to maintain a list of channels that have completed their operation. To provide further flexibility, MSP432P4x1x DMA supports four DMA completion interrupts, which are mapped in the following way:

- DMA_INT0: Logical OR of all completion events **except** those that are already mapped to DMA_INT1, DMA_INT2, or DMA_INT3.
- DMA_INT1, DMA_INT2, DMA_INT3: Can be mapped to the DMA completion event of any of the eight channels.

NOTE

Software must make sure that DMA_INT1, DMA_INT2, and DMA_INT3 are mapped to different channels, so that the same channel does not result in multiple interrupts at the NVIC.

6.5.3 DMA Access Privileges

The DMA has access to all of the memories and peripheral configuration interfaces of the device. If the device is configured for IP protection, DMA access to the flash is restricted to only bank 1 of the flash main and information memory regions. This restriction prevents the DMA from being used as an unauthorized access source into bank 0 of the flash, where secure data regions are housed.

6.6 Memory Map Access Details

The bus system on MSP432P4x1x devices incorporates four masters, which can initiate various types of transactions:

- ICODE: Cortex-M4 instruction fetch bus. Accesses the Code zone only
- DCODE: Cortex-M4 data and literal load/store bus. Accesses the Code zone only. Debugger accesses to Code zone also appear on this bus.
- SBUS: Cortex-M4 data read and write bus. Accesses to all zones except Code zones and PPB memory space only. Debugger accesses to this space also appear on this bus.
- DMA: Access to all zones except the PPB memory space

NOTE

The PPB space is dedicated only to the Cortex-M4 Private Peripheral Bus.

6.6.1 Master and Slave Access Priority Settings

Table 6-38 lists all the available masters (rows) and their access permissions to slaves (columns). If multiple masters can access one slave, the table lists access priorities if arbitration is required. A lower number in the table indicates a higher arbitration priority (the priority is always fixed).

Table 6-38. Master and Slave Access Priority

	FLASH MEMORY	ROM	SRAM	PERIPHERALS
ICODE	3	2	4	NA
DCODE	2 ⁽¹⁾	1	2	NA
SBUS	NA	NA	3	2
DMA	1 ⁽²⁾	NA	1 ⁽³⁾	1

- (1) Access from the DCODE to flash memory may be restricted if the device is operating in a secure mode
- (2) Access from DMA to flash memory is restricted to Bank 1 if the device is operating in a secure mode with IP protection enabled. In such cases, access to Bank 0 returns an error response
- (3) Although the SRAM is mapped to both Code and System spaces, accesses from DMA to SRAM must use the System space addressing only.

6.6.2 Memory Map Access Response

Table 6-39 summarizes the access responses to the entire memory map of MSP432P4x1x devices.

Table 6-39. Memory Map Access Response

ADDRESS RANGE	DESCRIPTION	READ ⁽¹⁾	WRITE ⁽¹⁾	INSTRUCTION FETCH ⁽¹⁾
0x0000_0000 to 0x001F_FFFF	Flash Main Memory	OK	OK ^{(2), (3)}	OK
0x0020_0000 to 0x0020_7FFF	Flash Information Memory	OK	OK ⁽³⁾	OK
0x0020_8000 to 0x00FF_FFFF	Reserved	Error	Error	Error
0x0100_0000 to 0x0103_FFFF	SRAM	OK	OK	OK
0x0104_0000 to 0x01FF_FFFF	Reserved	Error	Error	Error
0x0200_0000 to 0x0200_07FF	ROM (Reserved)	Error	Error	Error
0x0200_0800 to 0x0200_7FFF	ROM	OK	Error	OK
0x0200_8000 to 0x1FFF_FFFF	Reserved	Error	Error	Error
0x2000_0000 to 0x2003_FFFF	SRAM	OK	OK	OK
0x2004_0000 to 0x21FF_FFFF	Reserved	Error	Error	Error
0x2200_0000 to 0x23FF_FFFF	SRAM bit-band alias	OK ⁽⁴⁾	OK	Error
0x2400_0000 to 0x3FFF_FFFF	Reserved	Error	Error	Error
0x4000_0000 to 0x4001_FFFF	Peripheral	OK	OK	Error
0x4002_0000 to 0x41FF_FFFF	Reserved	Error	Error	Error
0x4200_0000 to 0x43FF_FFFF	Peripheral bit-band alias	OK ⁽⁴⁾	OK	Error
0x4400_0000 to 0xDFFF_FFFF	Reserved	Error	Error	Error
0xE000_0000 to 0xE003_FFFF	Internal PPB ⁽⁵⁾	OK	OK	Error
0xE004_0000 to 0xE004_0FFF	TPIU (External PPB)	OK	OK	Error
0xE004_1000 to 0xE004_1FFF	Reserved	Reserved	Reserved	Error
0xE004_2000 to 0xE004_23FF	Reset Controller (External PPB)	OK	OK	Error
0xE004_2400 to 0xE004_2FFF	Reserved	Reserved	Reserved	Error
0xE004_3000 to 0xE004_33FF	SYSCTL_A (External PPB)	OK	OK	Error
0xE004_3400 to 0xE004_3FFF	Reserved	Reserved	Reserved	Error
0xE004_4000 to 0xE004_43FF	SYSCTL_A (External PPB)	OK	OK	Error
0xE004_4400 to 0xE00F_EFFF	Reserved	Reserved	Reserved	Error
0xE00F_F000 to 0xE00F_FFFF	ROM Table (External PPB)	OK	OK	Error
0xE010_0000 to 0xFFFF_FFFF	Reserved	Error	Error	Error

(1) A reserved memory region returns 0h on reads and instruction fetches. Writes to this region are ignored.

(2) If the user memory address is part of a secure region, this access returns an error if it is initiated by an unauthorized source. For more details, see the device security application note.

(3) Writes to this address are ignored if the sector has write protection enabled.

(4) Reads from the bit-band region return 00h if the bit is clear and 01h if the bit is set.

(5) See the Cortex-M4 technical reference manual at www.arm.com for details of the memory map of the internal PPB.

6.7 Interrupts

The Cortex-M4 processor on MSP432P4x1x devices implements an NVIC with 64 external interrupt lines and 8 levels of priority. From an application perspective, the interrupt sources at the device level are divided into two classes, the NMI and the User Interrupts. Internally, the CPU exception model handles the various exceptions (internal and external events including CPU instruction, memory, and bus fault conditions) in a fixed and configurable order of priority. For details on the handling of various exception priorities (including CPU reset and fault models), see the Arm-V7M architecture reference manual at www.arm.com.

6.7.1 NMI

The NMI input of the NVIC has the following possible sources:

- External NMI pin (if configured in NMI mode)
- Oscillator fault condition
- Power Supply System (PSS) generated interrupts
- Power Control Manager (PCM) generated interrupts

6.7.2 Device-Level User Interrupts

Table 6-40 lists the various interrupt sources and their connection to the NVIC inputs.

NOTE

Some sources may have multiple interrupt conditions, in which case the appropriate interrupt status/flag register of the source must be examined to differentiate between the generating conditions.

Table 6-40. NVIC Interrupts

NVIC INTERRUPT INPUT	SOURCE	FLAGS IN SOURCE
INTISR[0]	PSS ⁽¹⁾	
INTISR[1]	CS ⁽¹⁾	
INTISR[2]	PCM ⁽¹⁾	
INTISR[3]	WDT_A	
INTISR[4]	FPU_INT ⁽²⁾	Combined interrupt from flags in the FPSCR (part of Cortex-M4 FPU)
INTISR[5]	FLCTL_A	FLCTL_A interrupt flags
INTISR[6]	COMP_E0	Comparator_E0 interrupt flags
INTISR[7]	COMP_E1	Comparator_E1 interrupt flags
INTISR[8]	Timer_A0	TA0CCTL0.CCIFG
INTISR[9]	Timer_A0	TA0CCTLx.CCIFG (x = 1 to 4), TA0CTL.TAIFG
INTISR[10]	Timer_A1	TA1CCTL0.CCIFG
INTISR[11]	Timer_A1	TA1CCTLx.CCIFG (x = 1 to 4), TA1CTL.TAIFG
INTISR[12]	Timer_A2	TA2CCTL0.CCIFG
INTISR[13]	Timer_A2	TA2CCTLx.CCIFG (x = 1 to 4), TA2CTL.TAIFG
INTISR[14]	Timer_A3	TA3CCTL0.CCIFG
INTISR[15]	Timer_A3	TA3CCTLx.CCIFG (x = 1 to 4), TA3CTL.TAIFG
INTISR[16]	eUSCI_A0	UART or SPI mode TX, RX, and status flags
INTISR[17]	eUSCI_A1	UART or SPI mode TX, RX, and status flags
INTISR[18]	eUSCI_A2	UART or SPI mode TX, RX, and status flags
INTISR[19]	eUSCI_A3	UART or SPI mode TX, RX, and status flags
INTISR[20]	eUSCI_B0	SPI or I ² C mode TX, RX, and status flags (I ² C in multiple-slave mode)
INTISR[21]	eUSCI_B1	SPI or I ² C mode TX, RX, and status flags (I ² C in multiple-slave mode)
INTISR[22]	eUSCI_B2	SPI or I ² C mode TX, RX, and status flags (I ² C in multiple-slave mode)
INTISR[23]	eUSCI_B3	SPI or I ² C mode TX, RX, and status flags (I ² C in multiple-slave mode)
INTISR[24]	Precision ADC	IFG[0-31], LOIFG, INIFG, HIIFG, RDYIFG, OVIFG, TOVIFG
INTISR[25]	Timer32_INT1	Timer32 interrupt for Timer 1
INTISR[26]	Timer32_INT2	Timer32 interrupt for Timer 2
INTISR[27]	Timer32_INTC	Timer32 combined interrupt

- (1) This source can also be mapped to the system NMI. See the [MSP432P4xx SimpleLink™ Microcontrollers Technical Reference Manual](#) for more details.
- (2) The FPU of the Cortex-M4 can generate interrupts due to multiple floating-point exceptions. It is the responsibility of software to process and clear the interrupt flags in the FPSCR.

Table 6-40. NVIC Interrupts (continued)

NVIC INTERRUPT INPUT	SOURCE	FLAGS IN SOURCE
INTISR[28]	AES256	AESRDYIFG
INTISR[29]	RTC_C	OFIFG, RDYIFG, TEVIFG, AIFG, RT0PSIFG, RT1PSIFG
INTISR[30]	DMA_ERR	DMA error interrupt
INTISR[31]	DMA_INT3	DMA completion interrupt 3
INTISR[32]	DMA_INT2	DMA completion interrupt 2
INTISR[33]	DMA_INT1	DMA completion interrupt 1
INTISR[34]	DMA_INT0 ⁽³⁾	DMA completion interrupt 0
INTISR[35]	I/O Port P1	P1IFG.x (x = 0 to 7)
INTISR[36]	I/O Port P2	P2IFG.x (x = 0 to 7)
INTISR[37]	I/O Port P3	P3IFG.x (x = 0 to 7)
INTISR[38]	I/O Port P4	P4IFG.x (x = 0 to 7)
INTISR[39]	I/O Port P5	P5IFG.x (x = 0 to 7)
INTISR[40]	I/O Port P6	P6IFG.x (x = 0 to 7)
INTISR[41]	LCD_F	LCD interrupt flags
INTISR[42]	Reserved	
INTISR[43]	Reserved	
INTISR[44]	Reserved	
INTISR[45]	Reserved	
INTISR[46]	Reserved	
INTISR[47]	Reserved	
INTISR[48]	Reserved	
INTISR[49]	Reserved	
INTISR[50]	Reserved	
INTISR[51]	Reserved	
INTISR[52]	Reserved	
INTISR[53]	Reserved	
INTISR[54]	Reserved	
INTISR[55]	Reserved	
INTISR[56]	Reserved	
INTISR[57]	Reserved	
INTISR[58]	Reserved	
INTISR[59]	Reserved	
INTISR[60]	Reserved	
INTISR[61]	Reserved	
INTISR[62]	Reserved	
INTISR[63]	Reserved	

(3) DMA_INT0 has a different functionality from DMA_INT1, DMA_INT2, or DMA_INT3. See [Section 6.5.2](#) for more details.

NOTE

The Interrupt Service Routine (ISR) must ensure that the relevant interrupt flag in the source peripheral is cleared before returning from the ISR. If this is not done, the same interrupt may be incorrectly triggered again as a new event, even though the event has already been processed by the ISR. As there may be a few cycles of delay between the execution of the write command and the actual write reflecting in the interrupt flag register of the peripheral, TI recommends performing the write and waiting for a few cycles before exiting the ISR. Alternatively, the application can read the flag to ensure that it is cleared before exiting the ISR.

6.8 System Control

System Control comprises the modules that govern the overall behavior of the device, including power management, operating modes, clocks, reset handling, and user configuration settings.

6.8.1 Device Resets

MSP432P4x1x devices support multiple classes of reset. Each class results in a different level of initiation of device logic, thus allowing the application developer to initiate different resets based reset requirements during code development and debug. The following subsections describe the classes of reset in the device.

6.8.1.1 Power On/Off Reset (POR)

The POR initiates a complete initialization of the application settings and device configuration information. This class of reset may be initiated either by the PSS, the PCM, the RSTn pin, the Clock System upon DCO external resistor short-circuit fault, or the device emulation logic (through the debugger). From an application perspective, all sources of POR return the device to the same state of initialization.

NOTE

Depending on the source of the reset, the device may exhibit different wake-up latencies from the POR. This implementation enables optimization of the reset recovery time.

6.8.1.2 Reboot Reset

The Reboot Reset is identical to the POR and allows the application to emulate a POR class reset without needing to reset the device or activate the RSTn pin. A Reboot Reset can also be initiated through the debugger and, hence, does not affect the debug connection to the device, while a POR terminates the debug connection.

6.8.1.3 Hard Reset

The hard reset resets all modules that are set up or modified by the application. This includes all peripherals and the nondebug logic of the Cortex-M4. MSP432P4x1x devices support up to 16 sources of hard reset. [Table 6-41](#) lists the reset source allocation. The Reset Controller registers can be used to identify the source of reset in the device. For further details, see the *Reset Controller* chapter in the *MSP432P4xx SimpleLink™ Microcontrollers Technical Reference Manual*.

Table 6-41. MSP432P4x1x Hard Reset Sources

RESET SOURCE NUMBER	SOURCE
0	SYSRESETREQ (system reset output of Cortex-M4)
1	WDT_A time-out ⁽¹⁾
2	WDT_A password violation ⁽¹⁾
3	FLCTL_A ⁽²⁾
4	Reserved ⁽³⁾
5	Reserved ⁽³⁾
6	Reserved ⁽³⁾
7	Reserved ⁽³⁾
8	Reserved ⁽³⁾
9	Reserved ⁽³⁾
10	Reserved ⁽³⁾
11	Reserved ⁽³⁾
12	Reserved ⁽³⁾
13	Reserved ⁽³⁾
14	CS ⁽⁴⁾
15	PCM ⁽⁵⁾

- (1) The WDT_A generated resets can be mapped either as a hard reset or a soft reset.
- (2) The flash controller can generate a reset if a voltage anomaly is detected that can corrupt only flash reads and not the rest of the system.
- (3) Reserved indicates that this source of hard reset is currently unused and left for future expansion.
- (4) The CS cannot initiate a hard reset, but if a hard reset occurs during clock source or frequency changes, the CS can extend the reset to allow the clocks to settle before releasing the system. This reduces the chance of nondeterministic behavior.
- (5) The PCM cannot initiate a hard reset, but if a hard reset causes power mode changes, the PCM can extend the reset to allow the system to settle before releasing the Reset. This reduces the chance of nondeterministic behavior.

6.8.1.4 Soft Reset

The soft reset resets only the execution component of the system, which is the nondebug logic in the Cortex-M4 and the WDT_A. This reset remains nonintrusive to all other peripherals and system components. MSP432P4x1x devices support up to 16 sources of soft reset. Table 6-42 lists the reset source allocation. The Reset Controller registers can be used to identify the source of reset in the design. For further details, see the *Reset Controller* chapter in the *MSP432P4xx SimpleLink™ Microcontrollers Technical Reference Manual*.

Table 6-42. MSP432P4x1x Soft Reset Sources

RESET SOURCE NUMBER	SOURCE
0	CPU LOCKUP condition (LOCKUP output of Cortex-M4)
1	WDT_A time-out ⁽¹⁾
2	WDT_A password violation ⁽¹⁾
3	Reserved ⁽²⁾
4	Reserved ⁽²⁾
5	Reserved ⁽²⁾
6	Reserved ⁽²⁾
7	Reserved ⁽²⁾
8	Reserved ⁽²⁾
9	Reserved ⁽²⁾
10	Reserved ⁽²⁾
11	Reserved ⁽²⁾
12	Reserved ⁽²⁾
13	Reserved ⁽²⁾
14	Reserved ⁽²⁾
15	Reserved ⁽²⁾

(1) The WDT_A generated resets can be mapped either as a hard reset or a soft reset.

(2) Reserved indicates that this source of soft reset is currently unused and left for future expansion.

NOTE

To support and enhance debug of reset conditions, the Reset Controller is located on the PPB of the device. This allows the Reset Controller to remain accessible even if the device is stuck in a hard or soft reset state. The Reset Controller permits overrides for hard and soft resets, thereby allowing an application to regain control of the device and isolate the cause of the stuck reset.

6.8.2 Power Supply System (PSS)

The PSS controls all the power supply related functionality of the device. The PSS consists of the components in the following sections.

6.8.2.1 VCCDET

The VCCDET monitors the input voltage applied at the DVCC and AVCC pins of the device. When the V_{CC} is found to be below the operating range of the VCCDET trip points, it generates a brownout condition, thereby initiating a device reset (POR class reset).

6.8.2.2 Supply Supervisor and Monitor for High Side (SVSMH)

The SVSMH supervises and monitors the V_{CC} . SVSMH has a programmable threshold setting and can be used by the application to generate a reset or an interrupt if the V_{CC} dips below the desired threshold. In supervisor mode, the SVSMH generates a device reset (POR class reset). In monitor mode, the SVSMH generates an interrupt. The SVSMH can also be disabled if monitoring and supervision of the supply voltage are not required (offers further power savings).

6.8.2.3 Core Voltage Regulator

MSP432P4x1x devices can be programmed to operate with either the LDO or the DC/DC as the voltage regulator for the digital logic in the core domain of the device. The DC/DC offers significant boost in power efficiency for high-current high-performance applications. The LDO is a highly efficient regulator that offers power advantages at lower V_{CC} ranges and in the ultra-low-power modes of operation.

The core operating voltage (output of the LDO or DC/DC) is automatically set by the device depending on the selected operating mode of the device (see [Table 6-43](#) for further details). The device offers seamless switching between LDO and DC/DC operating modes and also implements a seamless DC/DC fail-safe mechanism.

6.8.3 Power Control Manager (PCM)

The PCM controls the operating modes of the device and the switching between the modes. Mode selection is controlled by the application, which can choose modes to meet its power and performance requirements. [Table 6-43](#) lists the operating modes of the device.

Table 6-43. MSP432P4x1x Operating Modes

OPERATING MODE	DESCRIPTION
AM_LDO_VCORE0	LDO-based active mode, medium performance, core voltage level 0
LPM0_LDO_VCORE0	Same as AM_LDO_VCORE0, except that CPU is off (no code execution)
AM_LDO_VCORE1	LDO-based active mode, maximum performance, core voltage level 1
LPM0_LDO_VCORE1	Same as AM_LDO_VCORE1, except that CPU is off (no code execution)
AM_DCDC_VCORE0	DC/DC-based active mode, medium performance, core voltage level 0
LPM0_DCDC_VCORE0	Same as AM_DCDC_VCORE0, except that CPU is off (no code execution)
AM_DCDC_VCORE1	DC/DC-based active mode, maximum performance, core voltage level 1
LPM0_DCDC_VCORE1	Same as AM_DCDC_VCORE1, except that CPU is off (no code execution)
AM_LF_VCORE0	LDO-based low-frequency active mode, core voltage level 0
LPM0_LF_VCORE0	Same as AM_LF_VCORE0, except that CPU is off (no code execution)
AM_LF_VCORE1	LDO-based low-frequency active mode, core voltage level 1
LPM0_LF_VCORE1	Same as AM_LF_VCORE1, except that CPU is off (no code execution)
LPM3_VCORE0	LDO-based low-power mode with full state retention, core voltage level 0. In addition to RTC_C and WDT_A, other peripherals can be operational with an external or internal low-frequency clocks up to 128 kHz. See Table 6-44 for peripherals that are available in this mode.
LPM3_VCORE1	LDO-based low-power mode with full state retention, core voltage level 1. In addition to RTC_C and WDT_A, other peripherals can be operational with an external or internal low-frequency clocks up to 128 kHz. See Table 6-44 for peripherals that are available in this mode.
LPM4_VCORE0	LDO-based low-power mode with full state retention, core voltage level 0. Peripherals can be operational out of external clocks up to 128 kHz. See Table 6-44 for peripherals that are available in this mode.
LPM4_VCORE1	LDO-based low-power mode with full state retention, core voltage level 1. Peripherals can be operational out of external clocks up to 128 kHz. See Table 6-44 for peripherals that are available in this mode.
LPM3.5	LDO-based low-power mode, core voltage level 0, no retention of peripheral registers, RTC_C and WDT_A can be active
LPM4.5	Core voltage off, wakeup only through pin reset or wakeup-capable I/Os

6.8.3.1 Peripherals in LPM3 and LPM4

Most peripherals in MSP432P4x1x devices can be activated in LPM3 out of low-frequency internal or external clocks. LPM4 mode is LPM3 with peripherals not clocked from internal clock sources. Some analog modules can be operational in LPM4, because they do not require a clock to operate (for example, the comparator). Activating a peripheral in LPM3 or LPM4 increases the current consumption due to its active supply current contribution but also due to an additional idle current. To limit the idle current adder, certain peripherals are combined into power islands within the device. To achieve optimal current consumption, use modules within one group and limit the number of groups with active modules. The grouping is shown in [Table 6-44](#). Modules not listed in this table are either already included in the standard LPM3 current consumption or cannot be used in LPM3 or LPM4. The idle current adder is very small at room temperature (25°C) but increases at high temperatures (85°C); see the idle current parameters in the electrical characteristics section for details.

Table 6-44. Peripheral Groups (PG)

PG1	PG2	PG3
Timer_A0 eUSCI_A0 eUSCI_B0 Clock output on pins	Timer_A1, Timer_A2 eUSCI_A1, eUSCI_A2, eUSCI_A3 eUSCI_B1, eUSCI_B2, eUSCI_B3	Timer_A3 Precision ADC Comp_E0, Comp_E1 REF_A LCD_F

6.8.4 Clock System (CS)

The CS contains the sources of the various clocks in the device and also controls the mapping between sources and the clock domains in the device.

6.8.4.1 LFXT

The LFXT supports 32.768-kHz low-frequency crystals.

6.8.4.2 HFXT

The HFXT supports high-frequency crystals up to 48 MHz.

6.8.4.3 DCO

The DCO is a power-efficient tunable internal oscillator that generates up to 48 MHz. It also supports a high-precision mode when using an external precision resistor.

6.8.4.4 Very Low-Power Low-Frequency Oscillator (VLO)

The VLO is an ultra-low-power internal oscillator that generates a low-accuracy clock at typical frequency of 9.4 kHz.

6.8.4.5 Low-Frequency Reference Oscillator (REFO)

The REFO can be used as an alternate low-power lower-accuracy source of a 32.768-kHz clock instead of the LFXT. REFO can also be programmed to generate a 128-kHz clock.

6.8.4.6 Module Oscillator (MODOSC)

The MODOSC is an internal clock source that has a very low latency wake-up time. MODOSC is factory-calibrated to a frequency of 25 MHz. The MODOSC is typically used to supply a clock on request to modules like the ADC (when in 1-Msps conversion mode).

6.8.4.7 System Oscillator (SYSOSC)

The SYSOSC is a lower-frequency version of the MODOSC and is factory-calibrated to a frequency of 5 MHz. It drives the ADC sampling clock in the 200-ksps conversion mode. In addition, it is also used for timing of various system-level control and management operations.

6.8.4.8 Fail-Safe Mechanisms

All clock sources that operate with external components have a built-in fail-safe mechanism that automatically switches to the relevant backup source, thereby ensuring that spurious or unstable clocks never impact the device behavior. [Table 6-45](#) lists the different types of clock source faults and the corresponding fail-safe clocks.

Table 6-45. Fail-Safe Clocks

FAULT TYPE	FAIL-SAFE CLOCK
LFXT oscillator fault	REFO clock
HFXT oscillator fault	SYSOSC clock
DCO external resistor open-circuit fault	DCO clock in internal resistor mode

6.8.5 System Controller (SYSCTL_A)

The SYSCTL_A is a set of various miscellaneous features of the device, including device memory configuration, RSTn/NMI function selection, clock run/stop control, watchdog configuration for selecting reset classes and device NMI source configuration and status. In addition, the SYSCTL_A enables device security features like JTAG and SWD lock and IP protection, which can be used to protect unauthorized accesses either to the entire device memory map or to certain selected regions of the flash.

NOTE

Like with the Cortex-M4 system control registers (in the internal PPB space), the System Controller module registers are mapped to the Cortex-M4 external PPB. This keeps the System Controller module accessible even when hard or soft resets are active.

6.9 Peripherals

The following sections describe the peripherals that are available on the MSP432P4x1x devices. For details on these peripherals, see the [MSP432P4xx SimpleLink™ Microcontrollers Technical Reference Manual](#).

6.9.1 Digital I/O

Up to 10 8-bit I/O ports are implemented.

- All individual I/O bits are independently programmable.
- Any combination of input, output, and interrupt conditions is possible.
- Programmable pullup or pulldown on all ports
- Edge-selectable interrupt capability is available on ports P1 to P6.
- Wake-up capability from LPM3, LPM4, LPM3.5, and LPM4.5 modes on ports P1 to P6.
- Read/write access to port-control registers is supported by all instructions.
- Ports can be accessed byte-wise or in pairs (16-bit width).
- Capacitive Touch functionality is supported on all pins of ports P1 to P10 and PJ.
- Four 20-mA high-drive I/Os on pins P2.0 to P2.3
- Glitch filtering capability on selected digital I/Os

6.9.1.1 Glitch Filtering on Digital I/Os

Some of the interrupt and wake-up capable digital I/Os can suppress glitches through the use of analog glitch filter to prevent unintentional interrupt or wake-up during device operation. The analog filter suppresses a minimum of 250-ns wide glitches. The glitch filter on these selected digital I/Os is enabled by default. If the glitch filtering capability is not required in the application, it can be bypassed using the SYS_DIO_GLTFLT_CTL register. When GLTFLT_EN bit in this register is cleared, the glitch filters on all the digital I/Os are bypassed. The glitch filter is automatically bypassed on a digital I/O when it is configured for peripheral or analog functionality by programming the respective PySEL0.x and PySEL1.x registers.

NOTE

The glitch filter is implemented on the following digital I/Os on MSP432P4x1x devices: P1.0, P1.4, P1.5, P3.0, P3.4, P3.5, P6.6, and P6.7.

6.9.2 Port Mapping Controller (PMAPCTL)

The port mapping controller allows flexible and reconfigurable mapping of digital functions.

6.9.2.1 Port Mapping Definitions

The port mapping controller on MSP432P4x1x devices allows reconfigurable mapping of digital functions on ports P2, P3, and P7.

Table 6-46. Port Mapping Mnemonics and Functions

VALUE	PxMAPy MNEMONIC	INPUT PIN FUNCTION	OUTPUT PIN FUNCTION
0	PM_NONE	None	DVSS
1	PM_UCA0CLK	eUSCI_A0 clock input/output (direction controlled by eUSCI)	
2	PM_UCA0RXD	eUSCI_A0 UART RXD (direction controlled by eUSCI – input)	
	PM_UCA0SOMI	eUSCI_A0 SPI slave out master in (direction controlled by eUSCI)	
3	PM_UCA0TXD	eUSCI_A0 UART TXD (direction controlled by eUSCI – output)	
	PM_UCA0SIMO	eUSCI_A0 SPI slave in master out (direction controlled by eUSCI)	
4	PM_UCB0CLK	eUSCI_B0 clock input/output (direction controlled by eUSCI)	
5	PM_UCB0SDA	eUSCI_B0 I ² C data (open drain and direction controlled by eUSCI)	
	PM_UCB0SIMO	eUSCI_B0 SPI slave in master out (direction controlled by eUSCI)	
6	PM_UCB0SCL	eUSCI_B0 I ² C clock (open drain and direction controlled by eUSCI)	
	PM_UCB0SOMI	eUSCI_B0 SPI slave out master in (direction controlled by eUSCI)	
7	PM_UCA1STE	eUSCI_A1 SPI slave transmit enable (direction controlled by eUSCI)	
8	PM_UCA1CLK	eUSCI_A1 clock input/output (direction controlled by eUSCI)	
9	PM_UCA1RXD	eUSCI_A1 UART RXD (direction controlled by eUSCI – input)	
	PM_UCA1SOMI	eUSCI_A1 SPI slave out master in (direction controlled by eUSCI)	
10	PM_UCA1TXD	eUSCI_A1 UART TXD (direction controlled by eUSCI – output)	
	PM_UCA1SIMO	eUSCI_A1 SPI slave in master out (direction controlled by eUSCI)	
11	PM_UCA2STE	eUSCI_A2 SPI slave transmit enable (direction controlled by eUSCI)	
12	PM_UCA2CLK	eUSCI_A2 clock input/output (direction controlled by eUSCI)	
13	PM_UCA2RXD	eUSCI_A2 UART RXD (direction controlled by eUSCI – input)	
	PM_UCA2SOMI	eUSCI_A2 SPI slave out master in (direction controlled by eUSCI)	
14	PM_UCA2TXD	eUSCI_A2 UART TXD (direction controlled by eUSCI – output)	
	PM_UCA2SIMO	eUSCI_A2 SPI slave in master out (direction controlled by eUSCI)	
15	PM_UCB2STE	eUSCI_B2 SPI slave transmit enable (direction controlled by eUSCI)	
16	PM_UCB2CLK	eUSCI_B2 clock input/output (direction controlled by eUSCI)	
17	PM_UCB2SDA	eUSCI_B2 I ² C data (open drain and direction controlled by eUSCI)	
	PM_UCB2SIMO	eUSCI_B2 SPI slave in master out (direction controlled by eUSCI)	
18	PM_UCB2SCL	eUSCI_B2 I ² C clock (open drain and direction controlled by eUSCI)	
	PM_UCB2SOMI	eUSCI_B2 SPI slave out master in (direction controlled by eUSCI)	
19	PM_TA0CCR0A	TA0 CCR0 capture input CCI0A	TA0 CCR0 compare output Out0
20	PM_TA0CCR1A	TA0 CCR1 capture input CCI1A	TA0 CCR1 compare output Out1
21	PM_TA0CCR2A	TA0 CCR2 capture input CCI2A	TA0 CCR2 compare output Out2
22	PM_TA0CCR3A	TA0 CCR3 capture input CCI3A	TA0 CCR3 compare output Out3
23	PM_TA0CCR4A	TA0 CCR4 capture input CCI4A	TA0 CCR4 compare output Out4
24	PM_TA1CCR1A	TA1 CCR1 capture input CCI1A	TA1 CCR1 compare output Out1
25	PM_TA1CCR2A	TA1 CCR2 capture input CCI2A	TA1 CCR2 compare output Out2
26	PM_TA1CCR3A	TA1 CCR3 capture input CCI3A	TA1 CCR3 compare output Out3
27	PM_TA1CCR4A	TA1 CCR4 capture input CCI4A	TA1 CCR4 compare output Out4
28	PM_TA0CLK	Timer_A0 external clock input	None
	PM_C0OUT	None	Comparator-E0 output
29	PM_TA1CLK	Timer_A1 external clock input	None
	PM_C1OUT	None	Comparator-E1 output

Table 6-46. Port Mapping Mnemonics and Functions (continued)

VALUE	PxMAPy MNEMONIC	INPUT PIN FUNCTION	OUTPUT PIN FUNCTION
30	PM_DMAE0	DMAE0 input	None
	PM_SMCLK	None	SMCLK
31 (0FFh) ⁽¹⁾	PM_ANALOG	Disables the output driver and the input Schmitt trigger to prevent parasitic cross currents when applying analog signals.	

(1) The value of the PM_ANALOG mnemonic is 31. The port mapping registers are 5 bits wide, and the upper bits are ignored, which results in a read value of 31.

Table 6-47. Default Mapping

PIN NAME	PxMAPy MNEMONIC	INPUT PIN FUNCTION	OUTPUT PIN FUNCTION
P2.0/PM_UCA1STE/L11	PM_UCA1STE	eUSCI_A1 SPI slave transmit enable (direction controlled by eUSCI)	
P2.1/PM_UCA1CLK/L10	PM_UCA1CLK	eUSCI_A1 clock input/output (direction controlled by eUSCI)	
P2.2/PM_UCA1RXD/ PM_UCA1SOMI/L9	PM_UCA1RXD/ PM_UCA1SOMI	eUSCI_A1 UART RXD (direction controlled by eUSCI – input) eUSCI_A1 SPI slave out master in (direction controlled by eUSCI)	
P2.3/PM_UCA1TXD/ PM_UCA1SIMO/L8	PM_UCA1TXD/ PM_UCA1SIMO	eUSCI_A1 UART TXD (direction controlled by eUSCI – output)/ eUSCI_A1 SPI slave in master out (direction controlled by eUSCI)	
P2.4/PM_TA0.1/L23 ⁽¹⁾	PM_TA0CCR1A	TA0 CCR1 capture input CCI1A	TA0 CCR1 compare output Out1
P2.5/PM_TA0.2/L22 ⁽¹⁾	PM_TA0CCR2A	TA0 CCR2 capture input CCI2A	TA0 CCR2 compare output Out2
P2.6/PM_TA0.3/L21 ⁽¹⁾	PM_TA0CCR3A	TA0 CCR3 capture input CCI3A	TA0 CCR3 compare output Out3
P2.7/PM_TA0.4/L20 ⁽¹⁾	PM_TA0CCR4A	TA0 CCR4 capture input CCI4A	TA0 CCR4 compare output Out4
P3.0/PM_UCA2STE/L7	PM_UCA2STE	eUSCI_A2 SPI slave transmit enable (direction controlled by eUSCI)	
P3.1/PM_UCA2CLK/L6	PM_UCA2CLK	eUSCI_A2 clock input/output (direction controlled by eUSCI)	
P3.2/PM_UCA2RXD/ PM_UCA2SOMI/L5	PM_UCA2RXD/ PM_UCA2SOMI	eUSCI_A2 UART RXD (direction controlled by eUSCI – input)/ eUSCI_A2 SPI slave out master in (direction controlled by eUSCI)	
P3.3/PM_UCA2TXD/ PM_UCA2SIMO/L4	PM_UCA2TXD/ PM_UCA2SIMO	eUSCI_A2 UART TXD (direction controlled by eUSCI – output)/ eUSCI_A2 SPI slave in master out (direction controlled by eUSCI)	
P3.4/PM_UCB2STE/L3	PM_UCB2STE	eUSCI_B2 SPI slave transmit enable (direction controlled by eUSCI)	
P3.5/PM_UCB2CLK/L2	PM_UCB2CLK	eUSCI_B2 clock input/output (direction controlled by eUSCI)	
P3.6/PM_UCB2SIMO/ PM_UCB2SDA/L1	PM_UCB2SIMO/ PM_UCB2SDA	eUSCI_B2 SPI slave in master out (direction controlled by eUSCI)/ eUSCI_B2 I ² C data (open drain and direction controlled by eUSCI)	
P3.7/PM_UCB2SOMI/ PM_UCB2SCL/L0	PM_UCB2SOMI/ PM_UCB2SCL	eUSCI_B2 SPI slave out master in (direction controlled by eUSCI)/ eUSCI_B2 I ² C clock (open drain and direction controlled by eUSCI)	
P7.0/PM_SMCLK/ PM_DMAE0/R03	PM_SMCLK/ PM_DMAE0	DMAE0 input	SMCLK
P7.1/PM_C0OUT/ PM_TA0CLK/R13	PM_C0OUT/ PM_TA0CLK	Timer_A0 external clock input	Comparator-E0 output
P7.2/PM_C1OUT/ PM_TA1CLK/R23	PM_C1OUT/ PM_TA1CLK	Timer_A1 external clock input	Comparator-E1 output
P7.3/PM_TA0.0	PM_TA0CCR0A	TA0 CCR0 capture input CCI0A	TA0 CCR0 compare output Out0
P7.4/PM_TA1.4/C0.5/L31 ⁽¹⁾	PM_TA1CCR4A	TA1 CCR4 capture input CCI4A	TA1 CCR4 compare output Out4
P7.5/PM_TA1.3/C0.4/L30 ⁽¹⁾	PM_TA1CCR3A	TA1 CCR3 capture input CCI3A	TA1 CCR3 compare output Out3
P7.6/PM_TA1.2/C0.3/L29 ⁽¹⁾	PM_TA1CCR2A	TA1 CCR2 capture input CCI2A	TA1 CCR2 compare output Out2
P7.7/PM_TA1.1/C0.2/L28 ⁽¹⁾	PM_TA1CCR1A	TA1 CCR1 capture input CCI1A	TA1 CCR1 compare output Out1

(1) Not available on the 64-pin RGC package.

6.9.3 Timer_A

Timers TA0, TA1, TA2, and TA3 are 16-bit timers and counters (Timer_A type) with five capture/compare registers each. Each timer supports multiple captures and compares, PWM outputs, and interval timing. Each has extensive interrupt capabilities. Interrupts may be generated from the counter on overflow conditions and from each capture/compare register.

6.9.3.1 Timer_A Signal Connection Tables

Table 6-48 to Table 6-51 list the interface signals of the Timer_A modules on the device and connections of the interface signals to the corresponding pins or internal signals. The following rules apply to the naming conventions used.

- The first column lists the device level pin or internal signal that sources the clocks or triggers into the Timer. The default assumption is that these are pins, unless specifically marked as (internal). Nomenclature used for internal signals is as follows:
 - CxOUT: Output from Comparator x
 - TA_x_Cy: Output from Timer x, Capture/Compare module y
- The second column lists the input signals of the timer module.
- The third column lists the submodule of the timer and also implies the functionality [timer, capture (inputs or triggers), or compare (outputs or PWM)].
- The fourth column lists the output signals of the timer module.
- The fifth column lists the device-level pin or internal signal that is driven by the outputs of the timer. The default assumption is that these are pins, unless specifically marked as (internal).

NOTE

The pin names listed in the tables are the complete names. It is the responsibility of the software to ensure that the pin is used in the intended mode for the targeted timer functionality.

NOTE

Internal signals that are sourced by the timer outputs may connect to other modules (for example, other timers or the ADC) in the device (as trigger sources).

Table 6-48. TA0 Signal Connections

DEVICE INPUT PIN OR INTERNAL SIGNAL	MODULE INPUT SIGNAL	MODULE BLOCK	MODULE OUTPUT SIGNAL	DEVICE OUTPUT PIN OR INTERNAL SIGNAL
P7.1/PM_C0OUT/PM_TA0CLK	TACLK	Timer	N/A	N/A
ACLK (internal)	ACLK			
SMCLK (internal)	SMCLK			
C0OUT (internal)	INCLK	CCR0	TA0	P7.3/PM_TA0.0 TA0_C0 (internal)
P7.3/PM_TA0.0	CCI0A			
DV _{SS}	CCI0B			
DV _{SS}	GND			
DV _{CC}	V _{CC}	CCR1	TA1	P2.4/PM_TA0.1 TA0_C1 (internal) Precision ADC (internal) ADC14SHS _x = {1}
P2.4/PM_TA0.1	CCI1A			
ACLK (internal)	CCI1B			
DV _{SS}	GND			
DV _{CC}	V _{CC}	CCR2	TA2	P2.5/PM_TA0.2 TA0_C2 (internal) Precision ADC (internal) ADC14SHS _x = {2}
P2.5/PM_TA0.2	CCI2A			
C0OUT (internal)	CCI2B			
DV _{SS}	GND			
DV _{CC}	V _{CC}	CCR3	TA3	P2.6/PM_TA0.3 TA0_C3 (internal)
P2.6/PM_TA0.3	CCI3A			
C1OUT (internal)	CCI3B			
DV _{SS}	GND			
DV _{CC}	V _{CC}			

Table 6-48. TA0 Signal Connections (continued)

DEVICE INPUT PIN OR INTERNAL SIGNAL	MODULE INPUT SIGNAL	MODULE BLOCK	MODULE OUTPUT SIGNAL	DEVICE OUTPUT PIN OR INTERNAL SIGNAL
P2.7/PM_TA0.4	CCI4A	CCR4	TA4	P2.7/PM_TA0.4 TA0_C4 (internal)
TA1_C4 (Internal)	CCI4B			
DV _{SS}	GND			
DV _{CC}	V _{CC}			

Table 6-49. TA1 Signal Connections

DEVICE INPUT PIN OR INTERNAL SIGNAL	MODULE INPUT SIGNAL	MODULE BLOCK	MODULE OUTPUT SIGNAL	DEVICE OUTPUT PIN OR INTERNAL SIGNAL
P7.2/PM_C1OUT/PM_TA1CLK	TACLK	Timer	N/A	N/A
ACLK (internal)	ACLK			
SMCLK (internal)	SMCLK			
C1OUT (internal)	INCLK			
P8.0/UCB3STE/TA1.0/C0.1	CCI0A	CCR0	TA0	P8.0/UCB3STE/TA1.0/C0.1 TA1_C0 (internal)
DV _{SS}	CCI0B			
DV _{SS}	GND			
DV _{CC}	V _{CC}			
P7.7/PM_TA1.1/C0.2	CCI1A	CCR1	TA1	P7.7/PM_TA1.1/C0.2 TA1_C1 (internal) Precision ADC (internal) ADC14SHSx = {3}
ACLK (internal)	CCI1B			
DV _{SS}	GND			
DV _{CC}	V _{CC}			
P7.6/PM_TA1.2/C0.3	CCI2A	CCR2	TA2	P7.6/PM_TA1.2/C0.3 TA1_C2 (internal) Precision ADC (internal) ADC14SHSx = {4}
C0OUT (internal)	CCI2B			
DV _{SS}	GND			
DV _{CC}	V _{CC}			
P7.5/PM_TA1.3/C0.4	CCI3A	CCR3	TA3	P7.5/PM_TA1.3/C0.4 TA1_C3 (internal)
C1OUT (internal)	CCI3B			
DV _{SS}	GND			
DV _{CC}	V _{CC}			
P7.4/PM_TA1.4/C0.5	CCI4A	CCR4	TA4	P7.4/PM_TA1.4/C0.5 TA1_C4 (internal)
TA0_C4 (internal)	CCI4B			
DV _{SS}	GND			
DV _{CC}	V _{CC}			

Table 6-50. TA2 Signal Connections

DEVICE INPUT PIN OR INTERNAL SIGNAL	MODULE INPUT SIGNAL	MODULE BLOCK	MODULE OUTPUT SIGNAL	DEVICE OUTPUT PIN OR INTERNAL SIGNAL
P4.2/ACLK/TA2CLK/A11	TACLK	Timer	N/A	N/A
ACLK (internal)	ACLK			
SMCLK (internal)	SMCLK			
From Capacitive Touch I/O 0 (internal)	INCLK			
P8.1/UCB3CLK/TA2.0/C0.0	CCI0A	CCR0	TA0	P8.1/UCB3CLK/TA2.0/C0.0 TA2_C0 (internal)
DV _{SS}	CCI0B			
DV _{SS}	GND			
DV _{CC}	V _{CC}			
P5.6/TA2.1/VREF+/VeREF+/C1.7	CCI1A	CCR1	TA1	P5.6/TA2.1/VREF+/VeREF+/C1.7 TA2_C1 (internal) Precision ADC (internal) ADC14SHSx = {5}
ACLK (internal)	CCI1B			
DV _{SS}	GND			
DV _{CC}	V _{CC}			
P5.7/TA2.2/VREF-/VeREF-/C1.6	CCI2A	CCR2	TA2	P5.7/TA2.2/VREF-/VeREF-/C1.6 TA2_C2 (internal) Precision ADC (internal) ADC14SHSx = {6}
C0OUT (internal)	CCI2B			
DV _{SS}	GND			
DV _{CC}	V _{CC}			
P6.6/TA2.3/UCB3SIMO/UCB3SDA/C1.1	CCI3A	CCR3	TA3	P6.6/TA2.3/UCB3SIMO/ UCB3SDA/C1.1 TA2_C3 (internal)
TA3_C3 (internal)	CCI3B			
DV _{SS}	GND			
DV _{CC}	V _{CC}			
P6.7/TA2.4/UCB3SOMI/UCB3SCL/C1.0	CCI4A	CCR4	TA4	P6.7/TA2.4/UCB3SOMI/ UCB3SCL/C1.0 TA2_C4 (internal)
From Capacitive Touch I/O 0 (internal)	CCI4B			
DV _{SS}	GND			
DV _{CC}	V _{CC}			

Table 6-51. TA3 Signal Connections

DEVICE INPUT PIN OR INTERNAL SIGNAL	MODULE INPUT SIGNAL	MODULE BLOCK	MODULE OUTPUT SIGNAL	DEVICE OUTPUT PIN OR INTERNAL SIGNAL
P8.3/TA3CLK/A22	TACLK	Timer	N/A	N/A
ACLK (internal)	ACLK			
SMCLK (internal)	SMCLK			
From Capacitive Touch I/O 1 (internal)	INCLK			
P10.4/TA3.0/C0.7	CCI0A	CCR0	TA0	P10.4/TA3.0/C0.7 TA3_C0 (internal)
DV _{SS}	CCI0B			
DV _{SS}	GND			
DV _{CC}	V _{CC}			
P10.5/TA3.1/C0.6	CCI1A	CCR1	TA1	P10.5/TA3.1/C0.6 TA3_C1 (internal) Precision ADC (internal) ADC14SHSx = {7}
ACLK (internal)	CCI1B			
DV _{SS}	GND			
DV _{CC}	V _{CC}			
P8.2/TA3.2/A23	CCI2A	CCR2	TA2	P8.2/TA3.2/A23 TA3_C2 (internal)
C0OUT (internal)	CCI2B			
DV _{SS}	GND			
DV _{CC}	V _{CC}			
P9.2/TA3.3	CCI3A	CCR3	TA3	P9.2/TA3.3 TA3_C3 (internal)
TA2_C3 (internal)	CCI3B			
DV _{SS}	GND			
DV _{CC}	V _{CC}			
P9.3/TA3.4	CCI4A	CCR4	TA4	P9.3/TA3.4 TA3_C4 (internal)
From Capacitive Touch I/O 1 (internal)	CCI4B			
DV _{SS}	GND			
DV _{CC}	V _{CC}			

6.9.4 Timer32

Timer32 is an Arm dual 32-bit timer module. It contains two 32-bit timers, each of which can be configured as two independent 16-bit timers. The two timers can generate independent events or a combined event, which can be processed according to application requirements.

6.9.5 Enhanced Universal Serial Communication Interface (eUSCI)

The eUSCI modules are used for serial data communication. The eUSCI module supports synchronous communication protocols such as SPI (3-pin or 4-pin) and I²C, and asynchronous communication protocols such as UART, enhanced UART with automatic baud-rate detection, and IrDA.

The eUSCI_An module provides support for SPI (3-pin or 4-pin), UART, enhanced UART, and IrDA.

The eUSCI_Bn module provides support for SPI (3-pin or 4-pin) and I²C.

MSP432P4x1x devices offer up to four eUSCI_A and four eUSCI_B modules.

6.9.6 Real-Time Clock (RTC_C)

The RTC_C module contains an integrated real-time clock. It integrates an internal calendar which compensates for months with less than 31 days and includes leap year correction. The RTC_C also supports flexible alarm functions, offset calibration, and temperature compensation. The RTC_C operation is available in LPM3 and LPM3.5 modes to minimize power consumption.

6.9.7 Watchdog Timer (WDT_A)

The primary function of the WDT_A module is to perform a controlled system restart if a software problem occurs. If the selected time interval expires, a system reset is generated. If the watchdog function is not needed in an application, the module can be configured as an interval timer and can generate interrupts at selected time intervals.

The watchdog can generate a reset on either a time-out or a password violation. This reset can be configured to generate either a hard reset or a soft reset into the system. See the *WDT_A* chapter in the *MSP432P4xx SimpleLink™ Microcontrollers Technical Reference Manual* for more details.

Table 6-52. WDT_A Clocks

WDTSSSEL	NORMAL OPERATION (WATCHDOG AND INTERVAL TIMER MODE)
00	SMCLK
01	ACLK
10	VLOCLK
11	BCLK

CAUTION

The WDT must be set to interval mode before transitioning into the LPM3 or LPM3.5 modes of operation. This allows the WDT event to wake the device and return it to active modes of operation. Using the WDT in watchdog mode may result in nondeterministic behavior due to the generated reset.

6.9.8 Precision ADC

The Precision ADC module can achieve up to 16-bit precision with software oversampling, up to 1-Msps sampling rate with differential and single-ended inputs. The module implements a native 14-bit SAR core, sample-and-hold circuit, reference generator, and a conversion result buffer. The window comparators with lower and upper limits allow CPU-independent result monitoring through different window comparator interrupt flags.

Table 6-53 summarizes the available Precision ADC external trigger sources.

Table 6-53. Precision ADC Trigger Signal Connections

ADC14SHSx		CONNECTED TRIGGER SOURCE
BINARY	DECIMAL	
000	0	Software (ADC14SC)
001	1	TA0_C1
010	2	TA0_C2
011	3	TA1_C1
100	4	TA1_C2
101	5	TA2_C1
110	6	TA2_C2
111	7	TA3_C1

Table 6-54 and Table 6-55 list the available multiplexing between internal and external analog inputs of the Precision ADC.

Table 6-54. Precision ADC Channel Mapping on 100-Pin PZ Devices

PRECISION ADC CHANNEL	EXTERNAL CHANNEL SOURCE (CONTROL BIT = 0)	INTERNAL CHANNEL SOURCE (CONTROL BIT = 1) ⁽¹⁾	CONTROL BIT ⁽²⁾
Channel 23	A23	Battery Monitor	ADC14BATMAP
Channel 22	A22	Temperature Sensor	ADC14TCMAP
Channel 21	A21	N/A (Reserved)	ADC14CH0MAP
Channel 20	A20	N/A (Reserved)	ADC14CH1MAP
Channel 19	A19	N/A (Reserved)	ADC14CH2MAP
Channel 18	A18	N/A (Reserved)	ADC14CH3MAP

- (1) If an internal source is marked as N/A or Reserved, it indicates that only the external source is available for that channel.
(2) See the *Precision ADC* chapter in the *MSP432P4xx SimpleLink™ Microcontrollers Technical Reference Manual* for details on the registers that contain the control bits listed in the table.

Table 6-55. Precision ADC Channel Mapping on 64-Pin RGC Devices

PRECISION ADC CHANNEL	EXTERNAL CHANNEL SOURCE (CONTROL BIT = 0)	INTERNAL CHANNEL SOURCE (CONTROL BIT = 1) ⁽¹⁾	CONTROL BIT ⁽²⁾
Channel 23	N/A	Battery Monitor	ADC14BATMAP
Channel 22	N/A	Temperature Sensor	ADC14TCMAP
Channel 11	A11	N/A (Reserved)	ADC14BATMAP
Channel 10	A10	N/A (Reserved)	ADC14TCMAP
Channel 9	A9	N/A (Reserved)	ADC14CH0MAP
Channel 8	A8	N/A (Reserved)	ADC14CH1MAP
Channel 7	A7	N/A (Reserved)	ADC14CH2MAP
Channel 6	A6	N/A (Reserved)	ADC14CH3MAP

- (1) If an internal source is marked as N/A or Reserved, only the external source is available for that channel.
(2) See the *Precision ADC* chapter in the *MSP432P4xx SimpleLink™ Microcontrollers Technical Reference Manual* for details on the registers that contain the control bits listed in the table.

6.9.9 Comparator_E (COMP_E)

The primary function of the COMP_E module is to support precision slope analog-to-digital conversions, battery voltage supervision, and monitoring of external analog signals.

Two COMP_E modules are available on MSP432P4x1x devices.

6.9.10 Shared Reference (REF_A)

The REF_A generates all critical reference voltages that can be used by the various analog peripherals in the device. The reference voltage from REF_A can also be output on a device pin for external use.

6.9.11 LCD Controller (LCD_F)

The LCD_F driver generates the segment and common signals that are required to drive a liquid crystal display (LCD). The LCD_F controller has dedicated data memories to hold segment drive information. Common and segment signals are generated as defined by the mode. Static, 2-mux, 3-mux, 4-mux, and 8-mux LCDs are supported. The module also provides an automatic blinking capability for individual segments. The module provides for automatic animation capability over eight of the segment lines.

6.9.12 CRC32

The CRC32 module produces a signature based on a sequence of entered data values and can be used for data checking purposes. It supports both a CRC32 and a CRC16 computation.

- The CRC16 computation signature is based on the CRC16-CCITT standard.
- The CRC32 computation signature is based on the CRC32-ISO 3309 standard.

6.9.13 AES256 Accelerator

The AES accelerator module performs encryption and decryption of 128-bit data with 128-, 192-, or 256-bit keys according to the Advanced Encryption Standard (AES) (FIPS PUB 197) in hardware.

6.9.14 True Random Seed

The Device Descriptor Information (TLV) contains a 128-bit true random seed that can be used to implement a deterministic random number generator.

6.10 Code Development and Debug

MSP432P4x1x devices support various methods through which the user can carry out code development and debug on the device.

6.10.1 JTAG and Serial Wire Debug (SWD) Based Development, Debug and Trace

The device supports both 4-pin JTAG and the 2-pin SWD modes of operation. The device is compatible with all standard Cortex-M4 debuggers available in the market today. The debug logic in the device has been designed to remain minimally intrusive to the application state. In low-power modes, the user can enable the debugger to override the state of the PSS, thereby gaining access to debug and trace features.

In 2-pin SWD mode, the TDO pin can be used to export serial wire trace output (SWO) data. In addition, the TDI and TDO pins of the device can be reassigned as user I/Os. See [Section 6.12.24](#) and [Section 6.12.25](#) for more details.

NOTE

If the device has activated debug security, debugger accesses into the device is completely disabled. The debugger, however, is still be able to scan the run/halt state of the CPU. Further control of and visibility into the device is possible only after initiating a mass erase of the device flash contents.

6.10.2 Peripheral Halt Control

The Peripheral Halt Control register in the System Controller module gives the user independent control over the functionality of device peripherals during code development and debug. When the CPU is halted, the bits in this register can control whether the corresponding peripheral freezes its operation (such as incrementing, transmit, and receive) or continues its operation (debug remains nonintrusive). The registers of the peripheral remain accessible without regard to the values in the Peripheral Halt Control register.

6.10.3 Bootloader (BSL)

The BSL enables users to program flash or SRAM on the device using a UART or I2C or SPI serial interface. Access to the device memory through the BSL is protected by a user-defined password. [Table 6-56](#) lists the required BSL pins.

Table 6-56. BSL Pins and Functions

DEVICE PIN	BSL FUNCTION
P1.2	UART BSLRXD
P1.3	UART BSLTXD
P1.4	SPI BSLSTE
P1.5	SPI BSLCLK
P1.6	SPI BSLSIMO
P1.7	SPI BSLSOMI
P3.6	I ² C BSLSDA
P3.7	I ² C BSLSCL

The BSL is invoked under any of the following conditions:

- Erasure of flash main memory
- Hardware invocation of BSL
- Software-based API calls to BSL functions

The user can perform hardware invocation of BSL using any pin of ports P1, P2, or P3. The pin selected for this purpose must not be one of the pins used for BSL. The user can configure the device pin and its polarity through the flash boot-override mailbox. The BSL can then be invoked on a power cycle or POR reset event with the configured pin.

For the complete description of the BSL features and its implementation, see the [MSP432P4xx SimpleLink™ Microcontrollers Bootloader \(BSL\) User's Guide](#).

6.10.4 Device Security

The MSP432P4x1x MCUs offer the following two types of device security for the user application code programmed on to the device.

- JTAG and SWD lock
- IP protection

JTAG and SWD lock as the name indicates locks the JTAG and SWD interface of the device. IP protection is useful for protection of customer software IP, for example, in multiple-vendor development scenarios. It is possible to have up to four IP protected zones with configurable start address and size. The security configurations of the device are done using the flash boot-override mailbox.

Also the SYSCCTL_A module provides infrastructure for encrypted in-field updates to the application code on devices that are JTAG and SWD locked or have defined IP protection zones. For complete details of the device security features, see SYSCCTL_A chapter in the [MSP432P4xx SimpleLink™ Microcontrollers Technical Reference Manual](#).

6.11 Performance Benchmarks

The MSP432P4x1x MCUs achieve the following performance benchmarks under the software configurations and profile configurations in the following sections. These performance benchmarks were measured with system supply voltage of 2.97 V at ambient temperature of 25°C.

6.11.1 ULPBench Performance: 150.6 ULPMark™-CP

Table 6-57 lists the software configuration for the ULPBench benchmark.

Table 6-57. Software Configuration

ITEM	DETAILS
Compiler name and version	IAR EWARM v7.50.3
Compiler flags	--endian=little --cpu=Cortex-M4F -e --fpu=VFPv4_sp -Ohs --no_size_constraints --mfc
ULPBench profile and version	v1.1.x
EnergyMonitor software version	1.1.3

Table 6-58 lists the profile configuration for the ULPBench benchmark.

Table 6-58. Profile Configuration

CONFIGURATION	DETAILS
Wakeup Timer Module	RTC
Wakeup Timer Clock Source	External crystal
Wakeup Timer Frequency	32768 Hz
Wakeup Timer Accuracy	20 ppm
Active Power Mode Name	Active mode
Active Mode Clock Configuration	CPU: 21 MHz, RTC: 32 kHz
Active Mode Voltage Integrity	1.62 V
Inactive Power Mode Name	LPM3
Inactive Clock Configuration	CPU: off, RTC: 32 kHz
Inactive Mode Voltage Integrity	1.62 V

6.11.2 CoreMark/MHz Performance: 3.41

Table 6-59 lists the software configuration for the CoreMark benchmark.

Table 6-59. Software Configuration

ITEM	DETAILS
Compiler Name and Version	IAR EWARM v6.70.3
Compiler Flags	--no_size_constraints --debug --endian=little --cpu=Cortex-M4F -e --fpu=None --dlib_config C:\Program Files (x86)\IAR Systems\Embedded Workbench 6.1\arm\INC\c\DLib_Config_Normal.h -Ohs
CoreMark Profile and Version	v1.0

Table 6-60 lists the profile configuration for the CoreMark benchmark.

Table 6-60. Profile Configuration

CONFIGURATION	DETAILS
Active Power Mode Name	Active mode
Active Mode Clock Configuration	CPU: 3 MHz
Active Mode Voltage Integrity	1.62 V

6.11.3 DMIPS/MHz (Dhrystone 2.1) Performance: 1.22

Table 6-61 lists the software configuration for the Dhrystone benchmark.

Table 6-61. Software Configuration

ITEMS	DETAILS
Compiler Name and Version	Keil μ Vision Arm Compiler v5.06(build 20)
Compiler Flags	-c --cpu Cortex-M4.fp -g -O3 -Otime --apcs=interwork --asm --interleave --asm_dir
Dhrystone Profile and Version	v2.1

Table 6-62 lists the profile configuration for the Dhrystone benchmark.

Table 6-62. Profile Configuration

CONFIGURATION	DETAILS
Active Power Mode Name	Active Mode
Active Mode Clock Configuration	CPU: 3 MHz
Active Mode Voltage Integrity	1.62 V

6.12 Input/Output Diagrams

6.12.1 Port P1 (P1.0 to P1.7) Input/Output With Schmitt Trigger

Figure 6-8 shows the port schematic. Table 6-63 lists the settings to select the port functions.

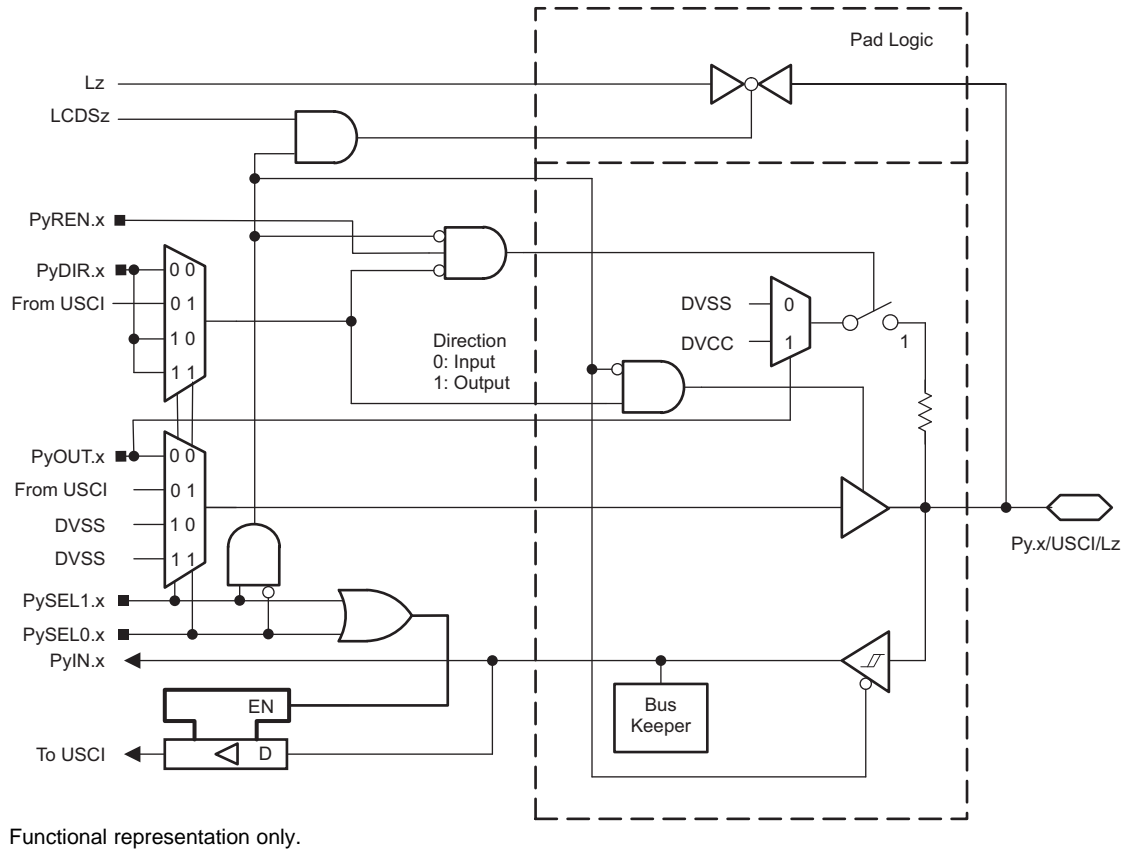

Figure 6-8. Py.x/USCI/Lz Port Schematic

Table 6-63. Port P1 (P1.0 to P1.7) Pin Functions

PIN NAME (P1.x)	x	FUNCTION	CONTROL BITS OR SIGNALS ⁽¹⁾		
			P1DIR.x	P1SEL1.x	P1SEL0.x
P1.0/UCA0STE/L19	0	P1.0 (I/O)	I: 0; O: 1	0	0
		UCA0STE	X ⁽²⁾	0	1
		L19 ⁽³⁾	X	1	0
		N/A	0	1	1
		DVSS	1		
P1.1/UCA0CLK/L18	1	P1.1 (I/O)	I: 0; O: 1	0	0
		UCA0CLK	X ⁽²⁾	0	1
		L18 ⁽³⁾	X	1	0
		N/A	0	1	1
		DVSS	1		
P1.2/UCA0RXD/UCA0SOMI/L17	2	P1.2 (I/O)	I: 0; O: 1	0	0
		UCA0RXD/UCA0SOMI	X ⁽²⁾	0	1
		L17 ⁽³⁾	X	1	0
		N/A	0	1	1
		DVSS	1		
P1.3/UCA0TXD/UCA0SIMO/L16	3	P1.3 (I/O)	I: 0; O: 1	0	0
		UCA0TXD/UCA0SIMO	X ⁽²⁾	0	1
		L16 ⁽³⁾	X	1	0
		N/A	0	1	1
		DVSS	1		
P1.4/UCB0STE/L15	4	P1.4 (I/O)	I: 0; O: 1	0	0
		UCB0STE	X ⁽⁴⁾	0	1
		L15 ⁽³⁾	X	1	0
		N/A	0	1	1
		DVSS	1		
P1.5/UCB0CLK/L14	5	P1.5 (I/O)	I: 0; O: 1	0	0
		UCB0CLK	X ⁽⁴⁾	0	1
		L14 ⁽³⁾	X	1	0
		N/A	0	1	1
		DVSS	1		
P1.6/UCB0SIMO/UCB0SDA/L13	6	P1.6 (I/O)	I: 0; O: 1	0	0
		UCB0SIMO/UCB0SDA	X ⁽⁴⁾	0	1
		L13 ⁽³⁾	X	1	0
		N/A	0	1	1
		DVSS	1		
P1.7/UCB0SOMI/UCB0SCL/L12	7	P1.7 (I/O)	I: 0; O: 1	0	0
		UCB0SOMI/UCB0SCL	X ⁽⁴⁾	0	1
		L12 ⁽³⁾	X	1	0
		N/A	0	1	1
		DVSS	1		

(1) X = Don't care

(2) Direction controlled by eUSCI_A0 module.

(3) Setting the PSEL1.x and PSEL0.x bits to 10 disables both the output driver and input Schmitt trigger to prevent leakage when analog signals are applied.

(4) Direction controlled by eUSCI_B0 module.

6.12.2 Port P2 (P2.0 to P2.3) Input/Output With Schmitt Trigger

Port Schematic: see [Figure 6-8](#)

[Table 6-64](#) lists the settings to select the port functions.

Table 6-64. Port P2 (P2.0 to P2.3) Pin Functions

PIN NAME (P2.x)	x	FUNCTION	CONTROL BITS OR SIGNALS ⁽¹⁾			
			P2DIR.x	P2SEL1.x	P2SEL0.x	P2MAPx
P2.0/PM_UCA1STE/L11	0	P2.0 (I/O)	I: 0; O: 1	0	0	X
		UCA1STE	X ⁽²⁾	0	1	default
		L11 ⁽³⁾	X	1	0	X
		N/A	0	1	1	X
		DVSS	1			
P2.1/PM_UCA1CLK/L10	1	P2.1 (I/O)	I: 0; O: 1	0	0	X
		UCA1CLK	X ⁽²⁾	0	1	default
		L10 ⁽³⁾	X	1	0	X
		N/A	0	1	1	X
		DVSS	1			
P2.2/PM_UCA1RXD/PM_UCA1SOMI/L9	2	P2.2 (I/O)	I: 0; O: 1	0	0	X
		UCA1RXD/UCA1SOMI	X ⁽²⁾	0	1	default
		L9 ⁽³⁾	X	1	0	X
		N/A	0	1	1	X
		DVSS	1			
P2.3/PM_UCA1TXD/PM_UCA1SIMO/L8	3	P2.3 (I/O)	I: 0; O: 1	0	0	X
		UCA1TXD/UCA1SIMO	X ⁽²⁾	0	1	default
		L8 ⁽³⁾	X	1	0	X
		N/A	0	1	1	X
		DVSS	1			

(1) X = Don't care

(2) Direction controlled by eUSCI_A1 module.

(3) Setting the PSEL1.x and PSEL0.x bits to 10 disables both the output driver and input Schmitt trigger to prevent leakage when analog signals are applied.

6.12.3 Port P3 (P3.0 to P3.7) Input/Output With Schmitt Trigger

Port Schematic: see [Figure 6-8](#)
[Table 6-65](#) lists the settings to select the port functions.

Table 6-65. Port P3 (P3.0 to P3.7) Pin Functions

PIN NAME (P3.x)	x	FUNCTION	CONTROL BITS OR SIGNALS ⁽¹⁾			
			P3DIR.x	P3SEL1.x	P3SEL0.x	P3MAPx
P3.0/PM_UCA2STE/L7	0	P3.0 (I/O)	I: 0; O: 1	0	0	X
		UCA2STE	X ⁽²⁾	0	1	default
		L7 ⁽³⁾	X	1	0	X
		N/A	0	1	1	X
		DVSS	1			
P3.1/PM_UCA2CLK/L6	1	P3.1 (I/O)	I: 0; O: 1	0	0	X
		UCA2CLK	X ⁽²⁾	0	1	default
		L6 ⁽³⁾	X	1	0	X
		N/A	0	1	1	X
		DVSS	1			
P3.2/PM_UCA2RXD/PM_UCA2SOMI/L5	2	P3.2 (I/O)	I: 0; O: 1	0	0	X
		UCA2RXD/UCA2SOMI	X ⁽²⁾	0	1	default
		L5 ⁽³⁾	X	1	0	X
		N/A	0	1	1	X
		DVSS	1			
P3.3/PM_UCA2TXD/PM_UCA2SIMO/L4	3	P3.3 (I/O)	I: 0; O: 1	0	0	X
		UCA2TXD/UCA2SIMO	X ⁽²⁾	0	1	default
		L4 ⁽³⁾	X	1	0	X
		N/A	0	1	1	X
		DVSS	1			
P3.4/PM_UCB2STE/L3	4	P3.4 (I/O)	I: 0; O: 1	0	0	X
		UCB2STE	X ⁽⁴⁾	0	1	default
		L3 ⁽³⁾	X	1	0	X
		N/A	0	1	1	X
		DVSS	1			
P3.5/PM_UCB2CLK/L2	5	P3.5 (I/O)	I: 0; O: 1	0	0	X
		UCB2CLK	X ⁽⁴⁾	0	1	default
		L2 ⁽³⁾	X	1	0	X
		N/A	0	1	1	X
		DVSS	1			
P3.6/PM_UCB2SIMO/PM_UCB2SDA/L1	6	P3.6 (I/O)	I: 0; O: 1	0	0	X
		UCB2SIMO/UCB2SDA	X ⁽⁴⁾	0	1	default
		L1 ⁽³⁾	X	1	0	X
		N/A	0	1	1	X
		DVSS	1			

(1) X = Don't care

(2) Direction controlled by eUSCI_A2 module.

(3) Setting the PSEL1.x and PSEL0.x bits to 10 disables both the output driver and input Schmitt trigger to prevent leakage when analog signals are applied.

(4) Direction controlled by eUSCI_B2 module.

Table 6-65. Port P3 (P3.0 to P3.7) Pin Functions (continued)

PIN NAME (P3.x)	x	FUNCTION	CONTROL BITS OR SIGNALS ⁽¹⁾			
			P3DIR.x	P3SEL1.x	P3SEL0.x	P3MAPx
P3.7/PM_UCB2SOMI/PM_UCB2SCL/L0	7	P3.7 (I/O)	I: 0; O: 1	0	0	X
		UCB2SOMI/UCB2SCL	X ⁽⁴⁾	0	1	default
		L0 ⁽³⁾	X	1	0	X
		N/A	0	1	1	X
		DVSS	1			

6.12.4 Port P9 (P9.4 to P9.7) Input/Output With Schmitt Trigger

Port Schematic: see [Figure 6-8](#)

[Table 6-66](#) lists the settings to select the port functions.

Table 6-66. Port P9 (P9.4 to P9.7) Pin Functions

PIN NAME (P9.x)	x	FUNCTION	CONTROL BITS OR SIGNALS ⁽¹⁾		
			P9DIR.x	P9SEL1.x	P9SEL0.x
P9.4/UCA3STE/L43 ⁽²⁾	4	P9.4 (I/O)	I: 0; O: 1	0	0
		UCA3STE	X ⁽³⁾	0	1
		L43 ⁽⁴⁾	X	1	0
		N/A	0	1	1
		DVSS	1		
P9.5/UCA3CLK/L42 ⁽²⁾	5	P9.5 (I/O)	I: 0; O: 1	0	0
		UCA3CLK	X ⁽³⁾	0	1
		L42 ⁽⁴⁾	X	1	0
		N/A	0	1	1
		DVSS	1		
P9.6/UCA3RXD/UCA3SOMI/L41 ⁽²⁾	6	P9.6 (I/O)	I: 0; O: 1	0	0
		UCA3RXD/UCA3SOMI	X ⁽³⁾	0	1
		L41 ⁽⁴⁾	X	1	0
		N/A	0	1	1
		DVSS	1		
P9.7/UCA3TXD/UCA3SIMO/L40 ⁽²⁾	7	P9.7 (I/O)	I: 0; O: 1	0	0
		UCA3TXD/UCA3SIMO	X ⁽³⁾	0	1
		L40 ⁽⁴⁾	X	1	0
		N/A	0	1	1
		DVSS	1		

(1) X = Don't care

(2) Not available on the 64-pin RGC package.

(3) Direction controlled by eUSCI_A3 module.

(4) Setting the PSEL1.x and PSEL0.x bits to 10 disables both the output driver and input Schmitt trigger to prevent leakage when analog signals are applied.

6.12.5 Port P10 (P10.0 to P10.3) Input/Output With Schmitt Trigger

Port Schematic: see [Figure 6-8](#)

[Table 6-67](#) lists the settings to select the port functions.

Table 6-67. Port P10 (P10.0 to P10.3) Pin Functions

PIN NAME (P10.x)	x	FUNCTION	CONTROL BITS OR SIGNALS ⁽¹⁾		
			P10DIR.x	P10SEL1.x	P10SEL0.x
P10.0/UCB3STE/L39 ⁽²⁾	0	P10.0 (I/O)	I: 0; O: 1	0	0
		UCB3STE	X ⁽³⁾	0	1
		L39 ⁽⁴⁾	X	1	0
		N/A	0	1	1
		DVSS	1		
P10.1/UCB3CLK/L38 ⁽²⁾	1	P10.1 (I/O)	I: 0; O: 1	0	0
		UCB3CLK	X ⁽³⁾	0	1
		L38 ⁽⁴⁾	X	1	0
		N/A	0	1	1
		DVSS	1		
P10.2/UCB3SIMO/UCB3SDA/L37 ⁽²⁾	2	P10.2 (I/O)	I: 0; O: 1	0	0
		UCB3SIMO/UCB3SDA	X ⁽³⁾	0	1
		L37 ⁽⁴⁾	X	1	0
		N/A	0	1	1
		DVSS	1		
P10.3/UCB3SOMI/UCB3SCL/L36 ⁽²⁾	3	P10.3 (I/O)	I: 0; O: 1	0	0
		UCB3SOMI/UCB3SCL	X ⁽³⁾	0	1
		L36 ⁽⁴⁾	X	1	0
		N/A	0	1	1
		DVSS	1		

(1) X = Don't care

(2) Not available on the 64-pin RGC package.

(3) Direction controlled by eUSCI_B3 module.

(4) Setting the PSEL1.x and PSEL0.x bits to 10 disables both the output driver and input Schmitt trigger to prevent leakage when analog signals are applied.

6.12.6 Port P2 (P2.4 to P2.7) Input/Output With Schmitt Trigger

Figure 6-9 shows the port schematic. Table 6-68 lists the settings to select the port functions.

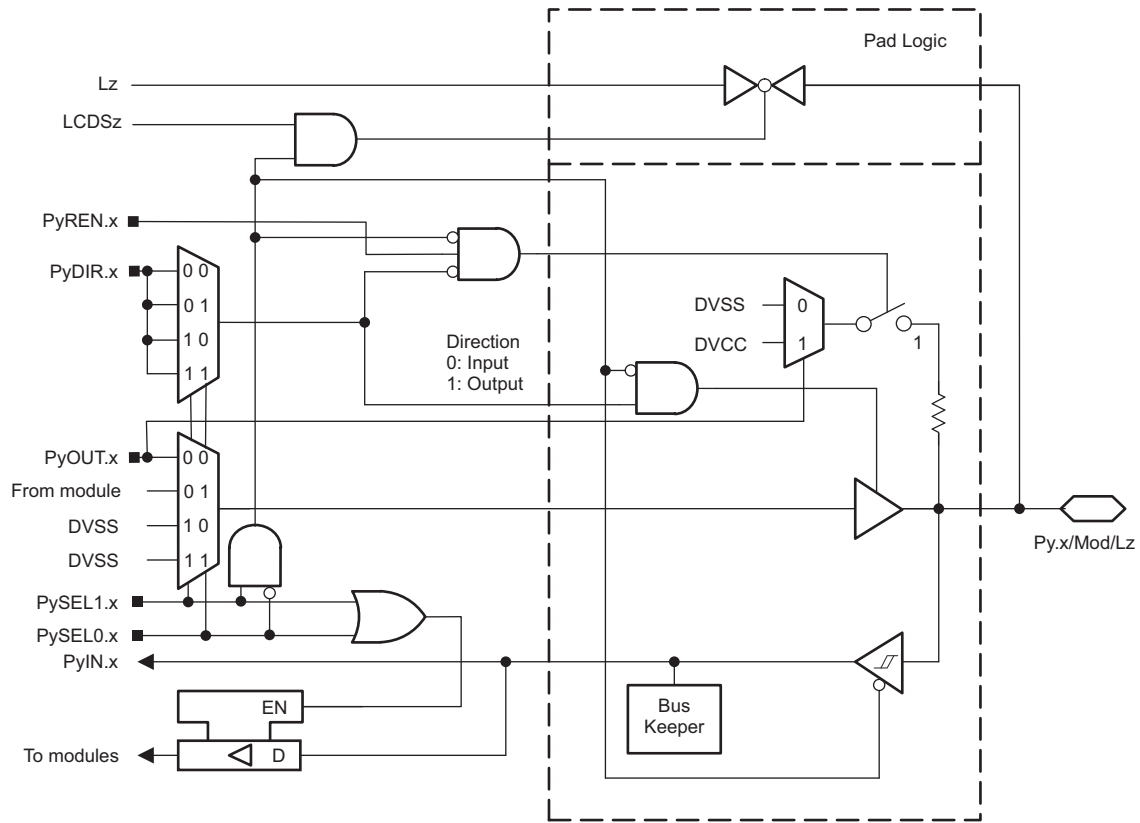

Functional representation only.

Figure 6-9. Py.x/Mod/Lz Port Schematic

Table 6-68. Port P2 (P2.4 to P2.7) Pin Functions

PIN NAME (P2.x)	x	FUNCTION	CONTROL BITS OR SIGNALS ⁽¹⁾			
			P2DIR.x	P2SEL1.x	P2SEL0.x	P2MAPx
P2.4/PM_TA0.1/L23 ⁽²⁾	4	P2.4 (I/O)	I: 0; O: 1	0	0	X
		TA0.CCI1A	0	0	1	default
		TA0.1	1			
		L23 ⁽³⁾	X	1	0	X
		N/A	0	1	1	X
		DVSS	1			
P2.5/PM_TA0.2/L22 ⁽²⁾	5	P2.5 (I/O)	I: 0; O: 1	0	0	X
		TA0.CCI2A	0	0	1	default
		TA0.2	1			
		L22 ⁽³⁾	X	1	0	X
		N/A	0	1	1	X
		DVSS	1			
P2.6/PM_TA0.3/L21 ⁽²⁾	6	P2.6 (I/O)	I: 0; O: 1	0	0	X
		TA0.CCI3A	0	0	1	default
		TA0.3	1			
		L21 ⁽³⁾	X	1	0	X
		N/A	0	1	1	X
		DVSS	1			
P2.7/PM_TA0.4/L20 ⁽²⁾	7	P2.7 (I/O)	I: 0; O: 1	0	0	X
		TA0.CCI4A	0	0	1	default
		TA0.4	1			
		L20 ⁽³⁾	X	1	0	X
		N/A	0	1	1	X
		DVSS	1			

(1) X = Don't care

(2) Not available on the 64-pin RGC package.

(3) Setting the PSEL1.x and PSEL0.x bits to 10 disables both the output driver and input Schmitt trigger to prevent leakage when analog signals are applied.

6.12.7 Port P7 (P7.0 to P7.2) Input/Output With Schmitt Trigger

Figure 6-10 shows the port schematic. Table 6-69 lists the settings to select the port functions.

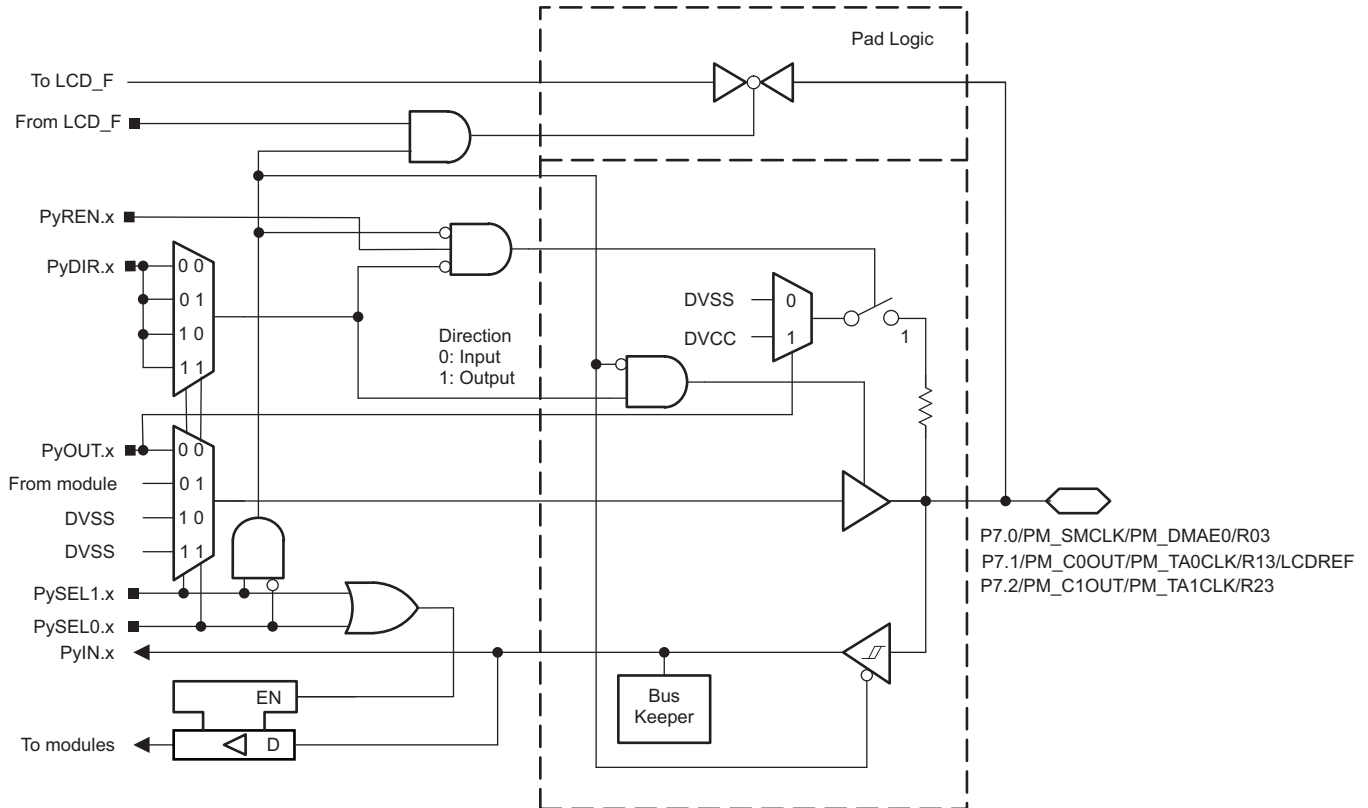

Figure 6-10. P7.0, P7.1 and P7.2 Port Schematic

Table 6-69. Port P7 (P7.0 to P7.2) Pin Functions

PIN NAME (P7.x)	x	FUNCTION	CONTROL BITS OR SIGNALS ⁽¹⁾			
			P7DIR.x	P7SEL1.x	P7SEL0.x	P7MAPx
P7.0/PM_SMCLK/ PM_DMAE0 R03	0	P7.0 (I/O)	I: 0; O: 1	0	0	X
		DMAE0	0	0	1	default
		SMCLK	1			
		R03 ⁽²⁾	X	1	0	X
		N/A	0	1	1	X
		DVSS	1			
P7.1/PM_C0OUT/ PM_TA0CLK R13	1	P7.1 (I/O)	I: 0; O: 1	0	0	X
		TA0CLK	0	0	1	default
		C0OUT	1			
		R13 ⁽²⁾	X	1	0	X
		N/A	0	1	1	X
		DVSS	1			

(1) X = Don't care

(2) Setting the PSEL1.x and PSEL0.x bits to 10 disables both the output driver and input Schmitt trigger to prevent leakage when analog signals are applied.

Table 6-69. Port P7 (P7.0 to P7.2) Pin Functions (continued)

PIN NAME (P7.x)	x	FUNCTION	CONTROL BITS OR SIGNALS ⁽¹⁾			
			P7DIR.x	P7SEL1.x	P7SEL0.x	P7MAPx
P7.2/PM_C1OUT/ PM_TA1CLK R23	2	P7.2 (I/O)	I: 0; O: 1	0	0	X
		TA1CLK	0	0	1	default
		C1OUT	1			
		R23 ⁽²⁾	X	1	0	X
		N/A	0	1	1	X
		DVSS	1			

6.12.8 Port P7 (P7.3) Input/Output With Schmitt Trigger

Figure 6-11 shows the port schematic. Table 6-70 lists the settings to select the port functions.

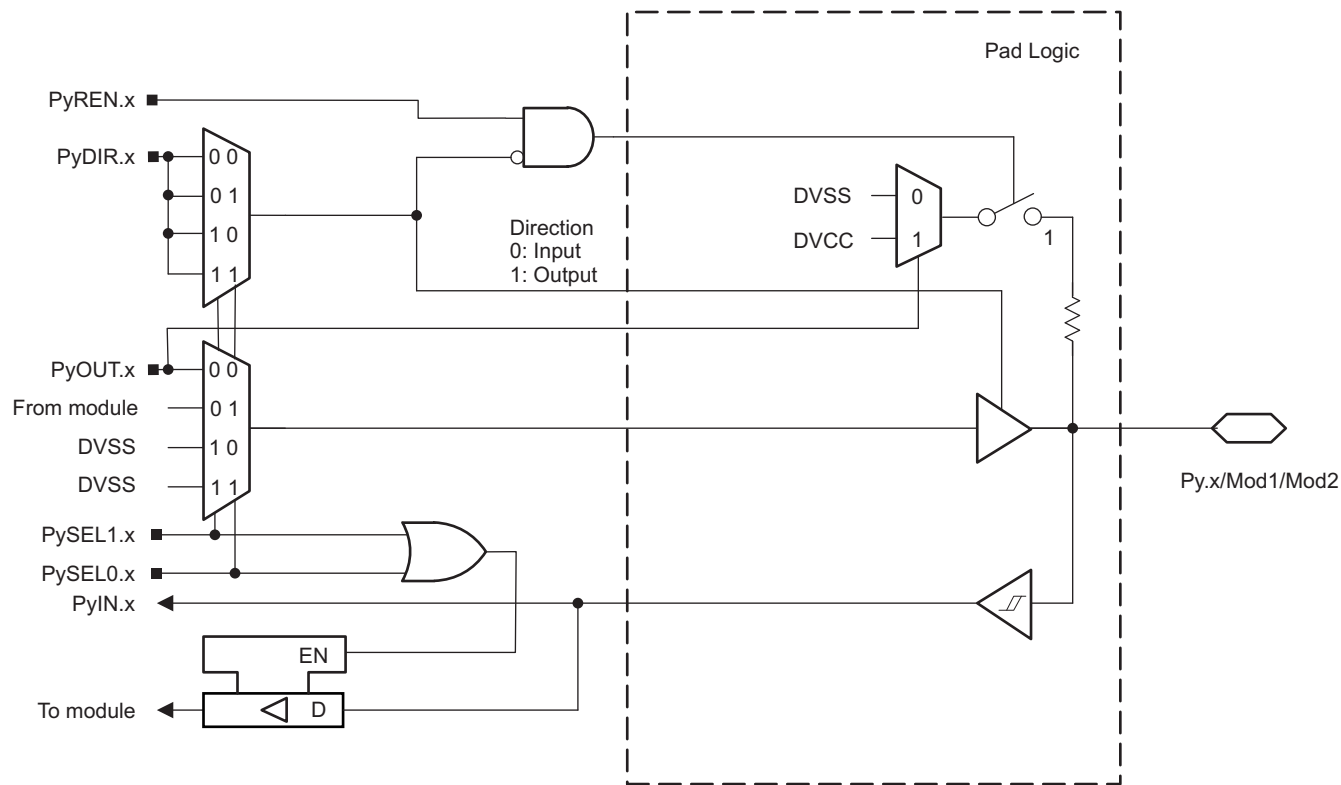

Figure 6-11. P7.3 Port Schematic

Table 6-70. Port P7 (P7.3) Pin Functions

PIN NAME (P7.x)	x	FUNCTION	CONTROL BITS OR SIGNALS ⁽¹⁾			
			P7DIR.x	P7SEL1.x	P7SEL0.x	P7MAPx
P7.3/PM_TA0.0	3	P7.3 (I/O)	I: 0; O: 1	0	0	X
		TA0.CCI0A	0	0	1	default
		TA0.0	1			
		N/A	X	1	0	X
		N/A	0	1	1	X
		DVSS	1			

(1) X = Don't care

6.12.9 Port P9 (P9.2 and P9.3) Input/Output With Schmitt Trigger

Port Schematic: see [Figure 6-9](#)

[Table 6-71](#) lists the settings to select the port functions.

Table 6-71. Port P9 (P9.2 and P9.3) Pin Functions

PIN NAME (P9.x)	x	FUNCTION	CONTROL BITS OR SIGNALS		
			P9DIR.x	P9SEL1.x	P9SEL0.x
P9.2/TA3.3/L33 ⁽¹⁾	2	P9.2 (I/O)	I: 0; O: 1	0	0
		TA3.CCI3A	0	0	1
		TA3.3	1		
		L33 ⁽²⁾	X	1	0
		N/A	0	1	1
		DVSS	1		
P9.3/TA3.4/L32 ⁽¹⁾	3	P9.3 (I/O)	I: 0; O: 1	0	0
		TA3.CCI4A	0	0	1
		TA3.4	1		
		L32 ⁽²⁾	X	1	0
		N/A	0	1	1
		DVSS	1		

(1) Not available on the 64-pin RGC package.

(2) Setting the PSEL1.x and PSEL0.x bits to 10 disables both the output driver and input Schmitt trigger to prevent leakage when analog signals are applied.

6.12.10 Port P4 (P4.2 to P4.7) Input/Output With Schmitt Trigger

Figure 6-12 shows the port schematic. Table 6-72 lists the settings to select the port functions.

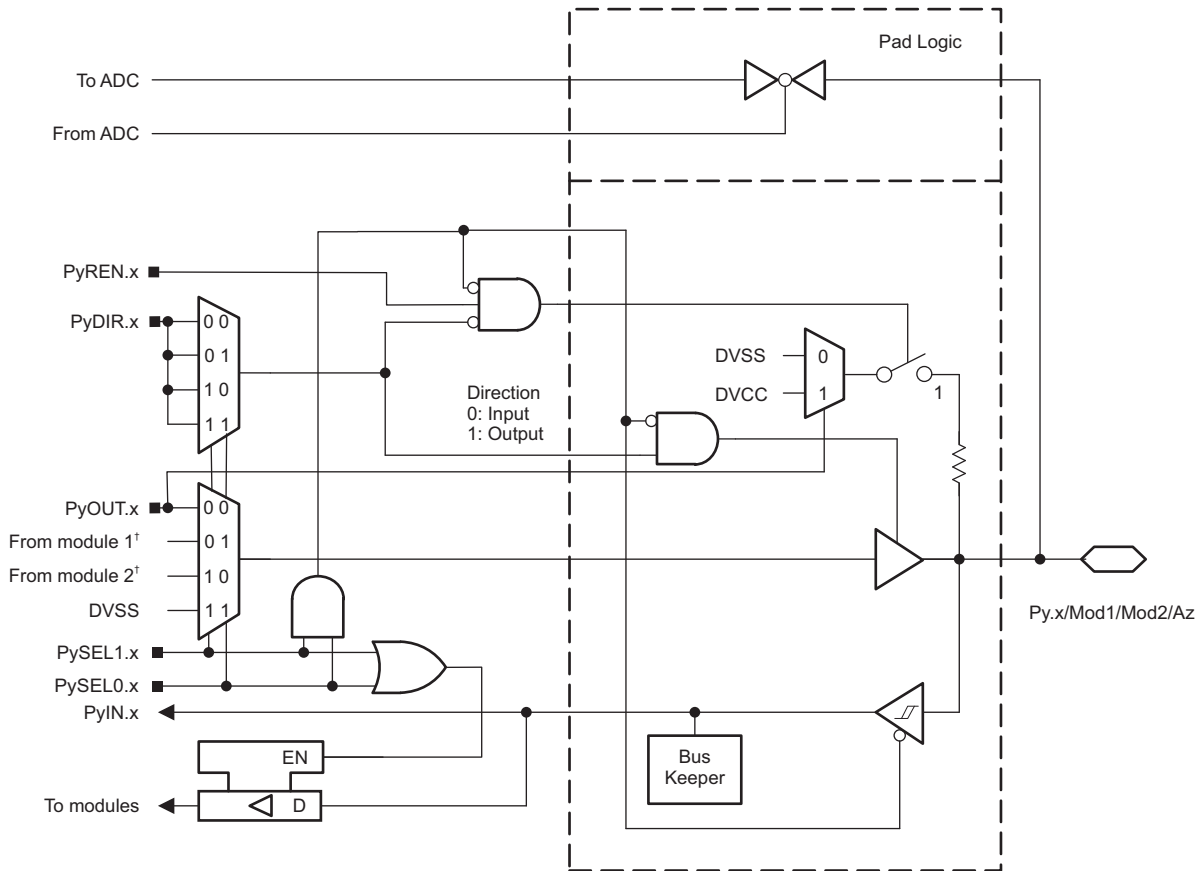

[†] Output is DVSS if module 1 or module 2 function is not available. See the pin function tables.
Functional representation only.

Figure 6-12. Py.x/Mod1/Mod2/Az Port Schematic

Table 6-72. Port P4 (P4.2 to P4.7) Pin Functions

PIN NAME (P4.x)	x	FUNCTION	CONTROL BITS OR SIGNALS ⁽¹⁾		
			P4DIR.x	P4SEL1.x	P4SEL0.x
P4.2/ACLK/TA2CLK/A11	2	P4.2 (I/O)	I: 0; O: 1	0	0
		N/A	0	0	1
		ACLK	1		
		TA2CLK	0	1	0
		DVSS	1		
		A11 ⁽²⁾	X		
P4.3/MCLK/RTCCLK/A10	3	P4.3 (I/O)	I: 0; O: 1	0	0
		N/A	0	0	1
		MCLK	1		
		N/A	0	1	0
		RTCCLK	1		
		A10 ⁽²⁾	X		
P4.4/HSMCLK/SVMHOUT/A9	4	P4.4 (I/O)	I: 0; O: 1	0	0
		N/A	0	0	1
		HSMCLK	1		
		N/A	0	1	0
		SVMHOUT	1		
		A9 ⁽²⁾	X		
P4.5/A8	5	P4.5 (I/O)	I: 0; O: 1	0	0
		N/A	0	0	1
		DVSS	1		
		N/A	0	1	0
		DVSS	1		
		A8 ⁽²⁾	X		
P4.6/A7	6	P4.6 (I/O)	I: 0; O: 1	0	0
		N/A	0	0	1
		DVSS	1		
		N/A	0	1	0
		DVSS	1		
		A7 ⁽²⁾	X		
P4.7/A6	7	P4.7 (I/O)	I: 0; O: 1	0	0
		N/A	0	0	1
		DVSS	1		
		N/A	0	1	0
		DVSS	1		
		A6 ⁽²⁾	X		

(1) X = Don't care

(2) Setting P4SEL1.x and P4SEL0.x disables the output driver and the input Schmitt trigger to prevent parasitic cross currents when applying analog signals.

6.12.11 Port P5 (P5.0 to P5.5) Input/Output With Schmitt Trigger

Port Schematic: see [Figure 6-12](#)

[Table 6-73](#) lists the settings to select the port functions.

Table 6-73. Port P5 (P5.0 to P5.5) Pin Functions

PIN NAME (P5.x)	x	FUNCTION	CONTROL BITS OR SIGNALS ⁽¹⁾		
			P5DIR.x	P5SEL1.x	P5SEL0.x
P5.0/A5	0	P5.0 (I/O)	I: 0; O: 1	0	0
		N/A	0	0	1
		DVSS	1		
		N/A	0	1	0
		DVSS	1		
		A5 ⁽²⁾	X		
P5.1/A4	1	P5.1 (I/O)	I: 0; O: 1	0	0
		N/A	0	0	1
		DVSS	1		
		N/A	0	1	0
		DVSS	1		
		A4 ⁽²⁾	X		
P5.2/A3	2	P5.2 (I/O)	I: 0; O: 1	0	0
		N/A	0	0	1
		DVSS	1		
		N/A	0	1	0
		DVSS	1		
		A3 ⁽²⁾	X		
P5.3/A2	3	P5.3 (I/O)	I: 0; O: 1	0	0
		N/A	0	0	1
		DVSS	1		
		N/A	0	1	0
		DVSS	1		
		A2 ⁽²⁾	X		
P5.4/A1	4	P5.4 (I/O)	I: 0; O: 1	0	0
		N/A	0	0	1
		DVSS	1		
		N/A	0	1	0
		DVSS	1		
		A1 ⁽²⁾	X		
P5.5/A0	5	P5.5 (I/O)	I: 0; O: 1	0	0
		N/A	0	0	1
		DVSS	1		
		N/A	0	1	0
		DVSS	1		
		A0 ⁽²⁾	X		

(1) X = Don't care

(2) Setting P5SEL1.x and P5SEL0.x disables the output driver and the input Schmitt trigger to prevent parasitic cross currents when applying analog signals.

6.12.12 Port P4 (P4.0 and P4.1) Input/Output With Schmitt Trigger

Figure 6-13 shows the port schematic. Table 6-74 lists the settings to select the port functions.

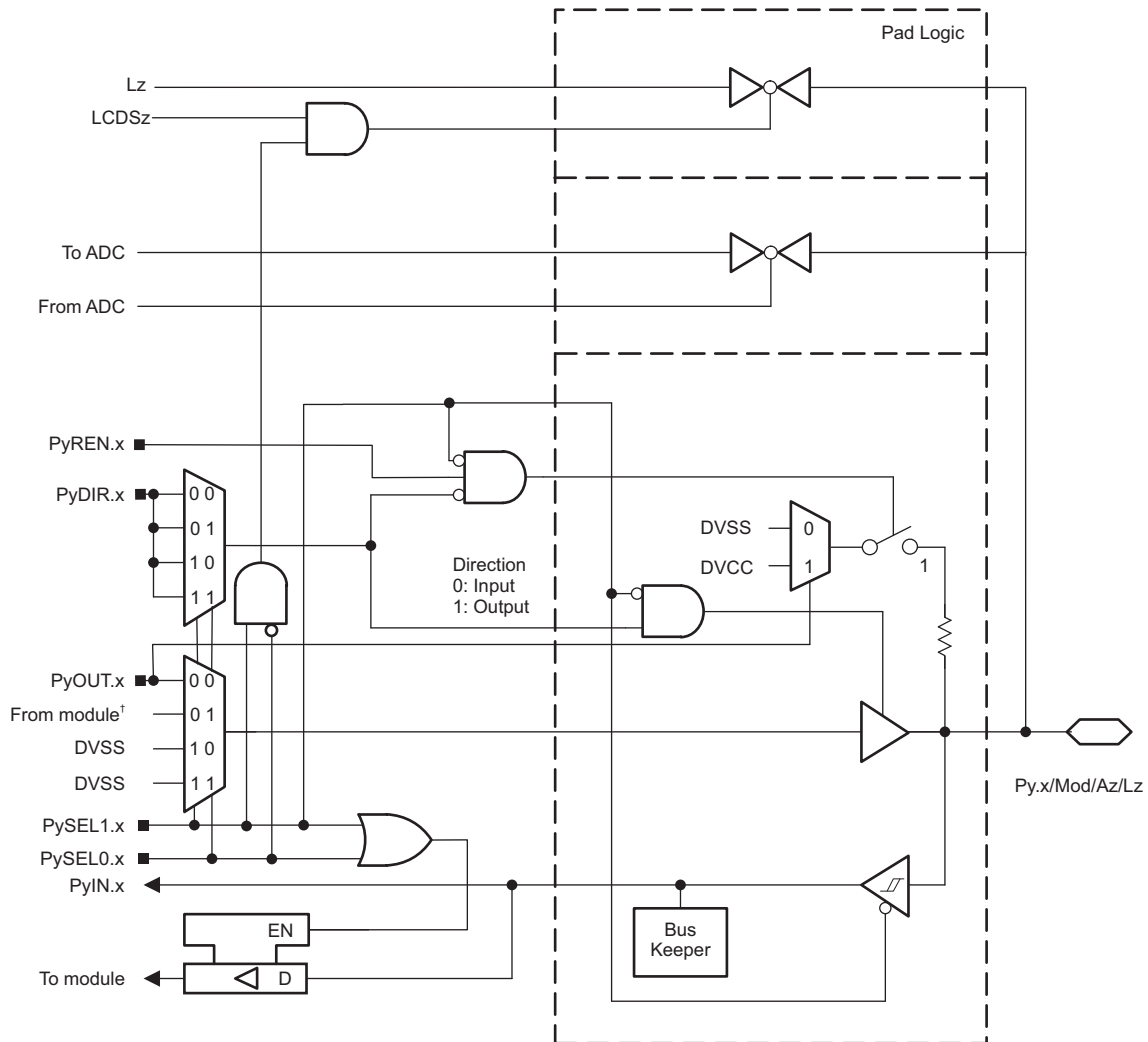

¹ Output is DVSS if module function is not available. See the pin function tables.

A. Functional representation only.

Figure 6-13. Py.x/Mod/Az/Lz Port Schematic

Table 6-74. Port P4 (P4.0 and P4.1) Pin Functions

PIN NAME (P4.x)	x	FUNCTION	CONTROL BITS OR SIGNALS ⁽¹⁾		
			P4DIR.x	P4SEL1.x	P4SEL0.x
P4.0/A13/L13 ⁽²⁾	0	P4.0 (I/O)	I: 0; O: 1	0	0
		N/A	0	0	1
		DVSS	1		
		L13 ⁽³⁾	X	1	0
		A13 ⁽⁴⁾	X	1	1
P4.1/A12/L12 ⁽²⁾	1	P4.1 (I/O)	I: 0; O: 1	0	0
		N/A	0	0	1
		DVSS	1		
		L12 ⁽³⁾	X	1	0
		A12 ⁽⁴⁾	X	1	1

- (1) X = Don't care
 (2) Not available on the 64-pin RGC package.
 (3) Setting the PSEL1.x and PSEL0.x bits to 10 disables both the output driver and input Schmitt trigger to prevent leakage when analog signals are applied.
 (4) Setting P4SEL1.x and P4SEL0.x disables the output driver and the input Schmitt trigger to prevent parasitic cross currents when applying analog signals.

NOTE

Take special care on the pins with ADC and LCD multiplexing to ensure that only one of these functions is enabled at any time.

6.12.13 Port P6 (P6.0 and P6.1) Input/Output With Schmitt Trigger

Port Schematic: see [Figure 6-13](#)

[Table 6-75](#) lists the settings to select the port functions.

Table 6-75. Port P6 (P6.0 and P6.1) Pin Functions

PIN NAME (P6.x)	x	FUNCTION	CONTROL BITS OR SIGNALS ⁽¹⁾		
			P6DIR.x	P6SEL1.x	P6SEL0.x
P6.0/A15/L15 ⁽²⁾	0	P6.0 (I/O)	I: 0; O: 1	0	0
		N/A	0	0	1
		DVSS	1		
		L15 ⁽³⁾	X	1	0
		A15 ⁽⁴⁾	X	1	1
P6.1/A14/L14 ⁽²⁾	1	P6.1 (I/O)	I: 0; O: 1	0	0
		N/A	0	0	1
		DVSS	1		
		L14 ⁽³⁾	X	1	0
		A14 ⁽⁴⁾	X	1	1

- (1) X = Don't care
- (2) Not available on the 64-pin RGC package.
- (3) Setting the PSEL1.x and PSEL0.x bits to 10 disables both the output driver and input Schmitt trigger to prevent leakage when analog signals are applied.
- (4) Setting P6SEL1.x and P6SEL0.x disables the output driver and the input Schmitt trigger to prevent parasitic cross currents when applying analog signals.

NOTE

Take special care on the pins with ADC and LCD multiplexing to ensure that only one of these functions is enabled at any time.

6.12.14 Port P8 (P8.2 to P8.7) Input/Output With Schmitt Trigger

Port Schematic: see [Figure 6-13](#)

[Table 6-76](#) lists the settings to select the port functions.

Table 6-76. Port P8 (P8.2 to P8.7) Pin Functions

PIN NAME (P8.x)	x	FUNCTION	CONTROL BITS OR SIGNALS ⁽¹⁾		
			P8DIR.x	P8SEL1.x	P8SEL0.x
P8.2/TA3.2/A23/L47 ⁽²⁾	2	P8.2 (I/O)	I: 0; O: 1	0	0
		TA3.CCI2A	0	0	1
		TA3.2	1		
		L47 ⁽³⁾	X	1	0
		A23 ⁽⁴⁾	X	1	1
P8.3/TA3CLK/A22/L46 ⁽²⁾	3	P8.3 (I/O)	I: 0; O: 1	0	0
		TA3CLK	0	0	1
		DVSS	1		
		L46 ⁽³⁾	X	1	0
		A22 ⁽⁴⁾	X	1	1
P8.4/A21/L45 ⁽²⁾	4	P8.4 (I/O)	I: 0; O: 1	0	0
		N/A	0	0	1
		DVSS	1		
		L45 ⁽³⁾	X	1	0
		A21 ⁽⁴⁾	X	1	1
P8.5/A20/L44 ⁽²⁾	5	P8.5 (I/O)	I: 0; O: 1	0	0
		N/A	0	0	1
		DVSS	1		
		L44 ⁽³⁾	X	1	0
		A20 ⁽⁴⁾	X	1	1
P8.6/A19/L19 ⁽²⁾	6	P8.6 (I/O)	I: 0; O: 1	0	0
		N/A	0	0	1
		DVSS	1		
		L19 ⁽³⁾	X	1	0
		A19 ⁽⁴⁾	X	1	1
P8.7/A18/L18 ⁽²⁾	7	P8.7 (I/O)	I: 0; O: 1	0	0
		N/A	0	0	1
		DVSS	1		
		L18 ⁽³⁾	X	1	0
		A18 ⁽⁴⁾	X	1	1

(1) X = Don't care

(2) Not available on the 64-pin RGC package.

(3) Setting the PSEL1.x and PSEL0.x bits to 10 disables both the output driver and input Schmitt trigger to prevent leakage when analog signals are applied.

(4) Setting P8SEL1.x and P8SEL0.x disables the output driver and the input Schmitt trigger to prevent parasitic cross currents when applying analog signals.

NOTE

Take special care on the pins with ADC and LCD multiplexing to ensure that only one of these functions is enabled at any time.

6.12.15 Port P9 (P9.0 and P9.1) Input/Output With Schmitt Trigger

Port Schematic: see [Figure 6-13](#)

[Table 6-77](#) lists the settings to select the port functions.

Table 6-77. Port P9 (P9.0 and P9.1) Pin Functions

PIN NAME (P9.x)	x	FUNCTION	CONTROL BITS OR SIGNALS ⁽¹⁾		
			P9DIR.x	P9SEL1.x	P9SEL0.x
P9.0/A17/L17 ⁽²⁾	0	P9.0 (I/O)	I: 0; O: 1	0	0
		N/A	0	0	1
		DVSS	1		
		L17 ⁽³⁾	X	1	0
		A17 ⁽⁴⁾	X	1	1
P9.1/A16/L16 ⁽²⁾	1	P9.1 (I/O)	I: 0; O: 1	0	0
		N/A	0	0	1
		DVSS	1		
		L16 ⁽³⁾	X	1	0
		A16 ⁽⁴⁾	X	1	1

- (1) X = Don't care
- (2) Not available on the 64-pin RGC package.
- (3) Setting the PSEL1.x and PSEL0.x bits to 10 disables both the output driver and input Schmitt trigger to prevent leakage when analog signals are applied.
- (4) Setting P9SEL1.x and P9SEL0.x disables the output driver and the input Schmitt trigger to prevent parasitic cross currents when applying analog signals.

NOTE

Take special care on the pins with ADC and LCD multiplexing to ensure that only one of these functions is enabled at any time.

6.12.16 Port P5 (P5.6 and P5.7) Input/Output With Schmitt Trigger

Figure 6-14 shows the port schematic. Table 6-78 lists the settings to select the port functions.

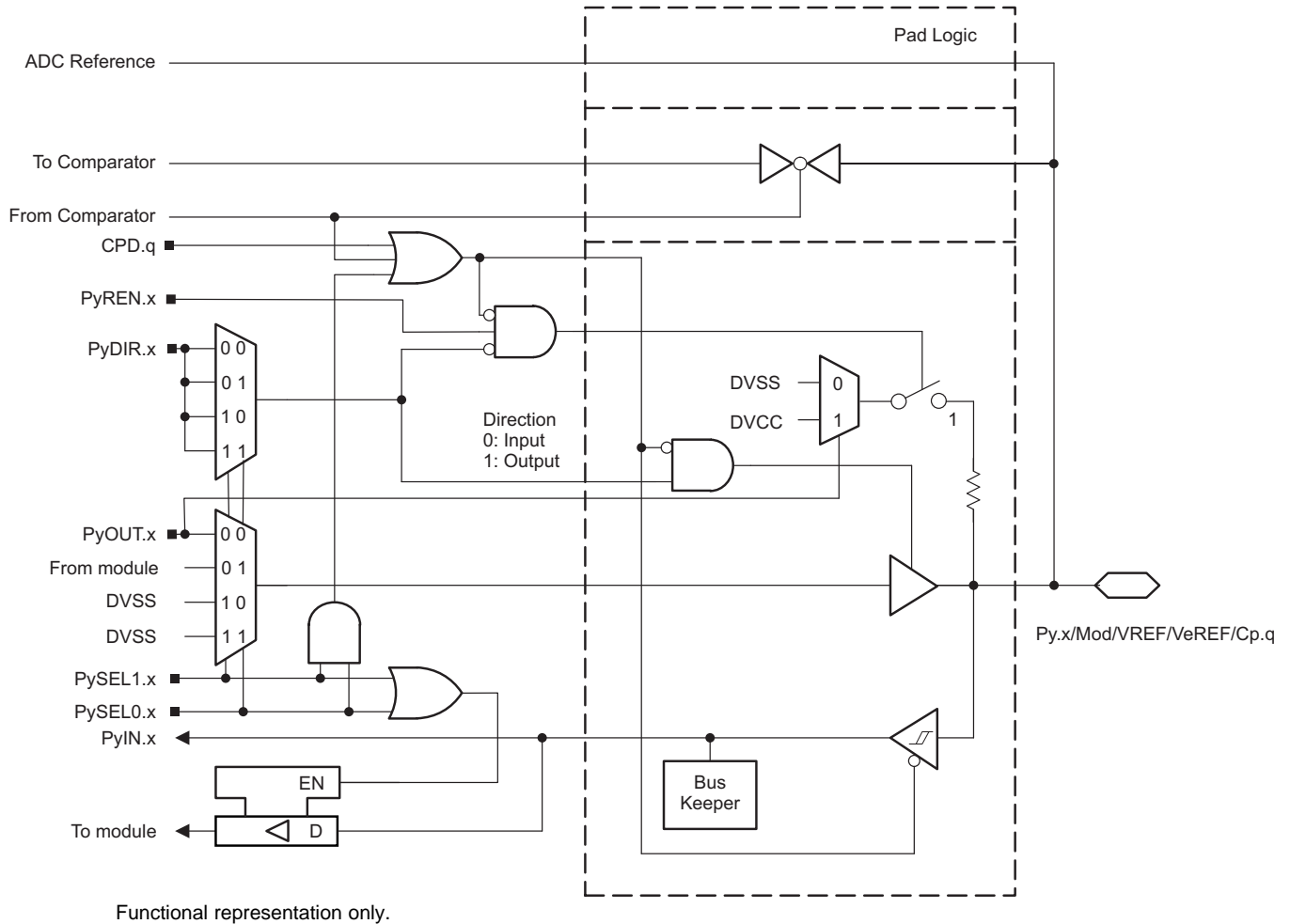

Figure 6-14. Py.x/Mod/VREF/VeREF/Cp.q Port Schematic

Table 6-78. Port P5 (P5.6 and P5.7) Pin Functions

PIN NAME (P5.x)	x	FUNCTION	CONTROL BITS OR SIGNALS ⁽¹⁾		
			P5DIR.x	P5SEL1.x	P5SEL0.x
P5.6/TA2.1/REF+/VeREF+/C1.7	6	P5.6 (I/O)	I: 0; O: 1	0	0
		TA2.CCI1A	0	0	1
		TA2.1	1		
		N/A	0	1	0
		DVSS	1		
		VREF+, VeREF+, C1.7 ^{(2) (3)}	X	1	1
P5.7/TA2.2/REF-/VeREF-/C1.6	7	P5.7 (I/O)	I: 0; O: 1	0	0
		TA2.CCI2A	0	0	1
		TA2.2	1		
		N/A	0	1	0
		DVSS	1		
		VREF-, VeREF-, C1.6 ^{(2) (3)}	X	1	1

- (1) X = Don't care
- (2) Setting P5SEL1.x and P5SEL0.x disables the output driver and the input Schmitt trigger to prevent parasitic cross currents when applying analog signals.
- (3) Setting the CEPD.q bit of the comparator disables the output driver and the input Schmitt trigger to prevent parasitic cross currents when applying analog signals. Selecting the C1.q input pin to the comparator multiplexer with the CEIPSEL or CEIMSEL bits automatically disables the output driver and input buffer for that pin, regardless of the state of the associated CEPD.q bit.

6.12.17 Port P6 (P6.2 to P6.5) Input/Output With Schmitt Trigger

Figure 6-15 shows the port schematic. Table 6-79 lists the settings to select the port functions.

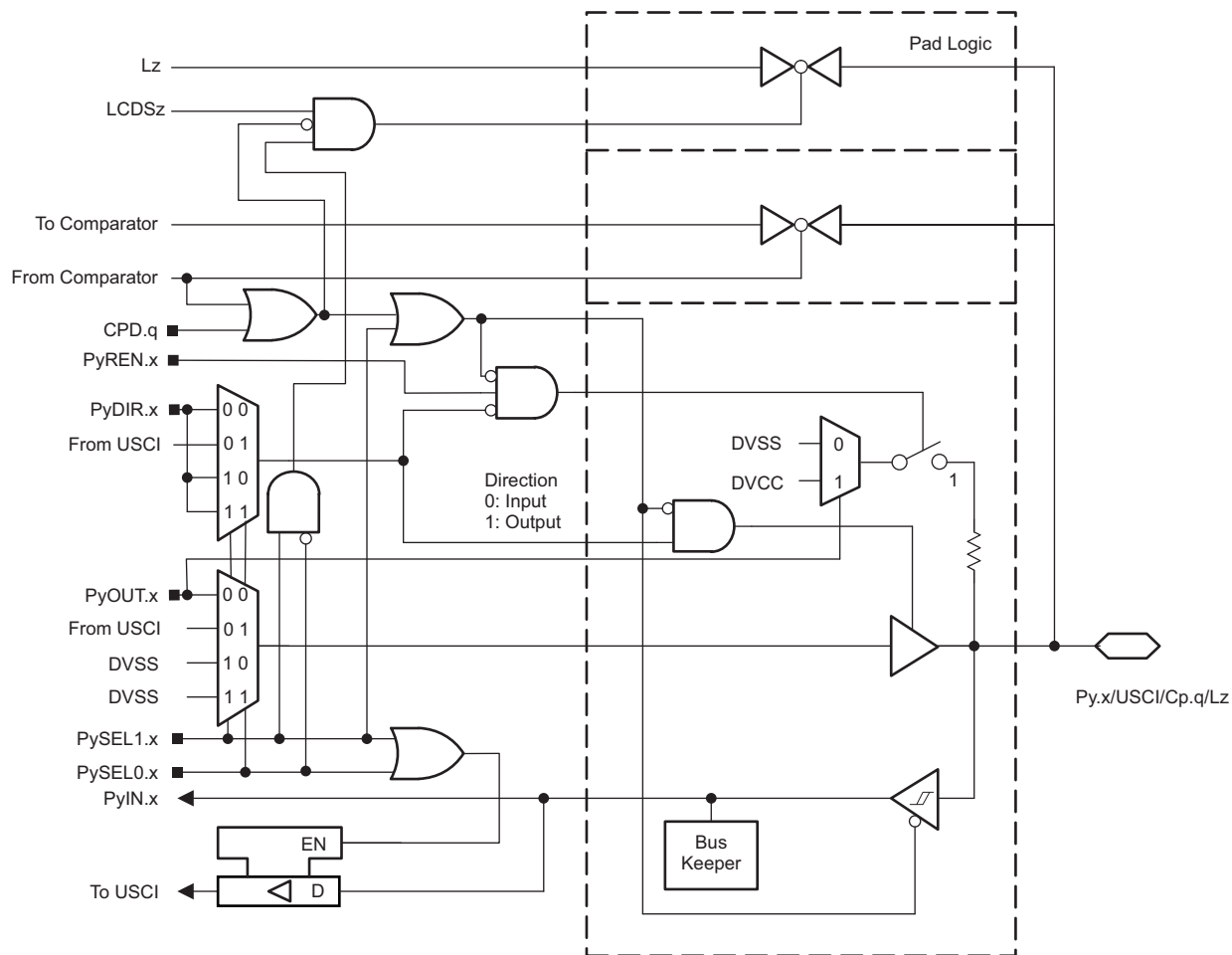

Functional representation only.

Figure 6-15. Py.x/USCI/Cp.q Port Schematic

Table 6-79. Port P6 (P6.2 to P6.5) Pin Functions

PIN NAME (P6.x)	x	FUNCTION	CONTROL BITS OR SIGNALS ⁽¹⁾		
			P6DIR.x	P6SEL1.x	P6SEL0.x
P6.2/UCB1STE/C1.5/L27 ⁽²⁾	2	P6.2 (I/O)	I: 0; O: 1	0	0
		UCB1STE	X ⁽³⁾	0	1
		L27 ⁽⁴⁾	X	1	0
		C1.5 ^{(5) (6)}	X	1	1
P6.3/UCB1CLK/C1.4/L26 ⁽²⁾	3	P6.3 (I/O)	I: 0; O: 1	0	0
		UCB1CLK	X ⁽³⁾	0	1
		L26 ⁽⁴⁾	X	1	0
		C1.4 ^{(5) (6)}	X	1	1
P6.4/UCB1SIMO/UCB1SDA/C1.3/L25 ⁽²⁾	4	P6.4 (I/O)	I: 0; O: 1	0	0
		UCB1SIMO/UCB1SDA	X ⁽³⁾	0	1
		L25 ⁽⁴⁾	X	1	0
		C1.3 ^{(5) (6)}	X	1	1
P6.5/UCB1SOMI/UCB1SCL/C1.2/L24 ⁽²⁾	5	P6.5 (I/O)	I: 0; O: 1	0	0
		UCB1SOMI/UCB1SCL	X ⁽³⁾	0	1
		L24 ⁽⁴⁾	X	1	0
		C1.2 ^{(5) (6)}	X	1	1

- (1) X = Don't care
- (2) Not available on the 64-pin RGC package.
- (3) Direction controlled by eUSCI_B1 module.
- (4) Setting the PSEL1.x and PSEL0.x bits to 10 disables both the output driver and input Schmitt trigger to prevent leakage when analog signals are applied.
- (5) Setting P6SEL1.x and P6SEL0.x disables the output driver and the input Schmitt trigger to prevent parasitic cross currents when applying analog signals.
- (6) Setting the CEPD.q bit of the comparator disables the output driver and the input Schmitt trigger to prevent parasitic cross currents when applying analog signals. Selecting the C1.q input pin to the comparator multiplexer with the CEIPSEL or CEIMSEL bits automatically disables the output driver and input buffer for that pin, regardless of the state of the associated CEPD.q bit.

6.12.18 Port P6 (P6.6 and P6.7) Input/Output With Schmitt Trigger

Figure 6-16 shows the port schematic. Table 6-80 lists the settings to select the port functions.

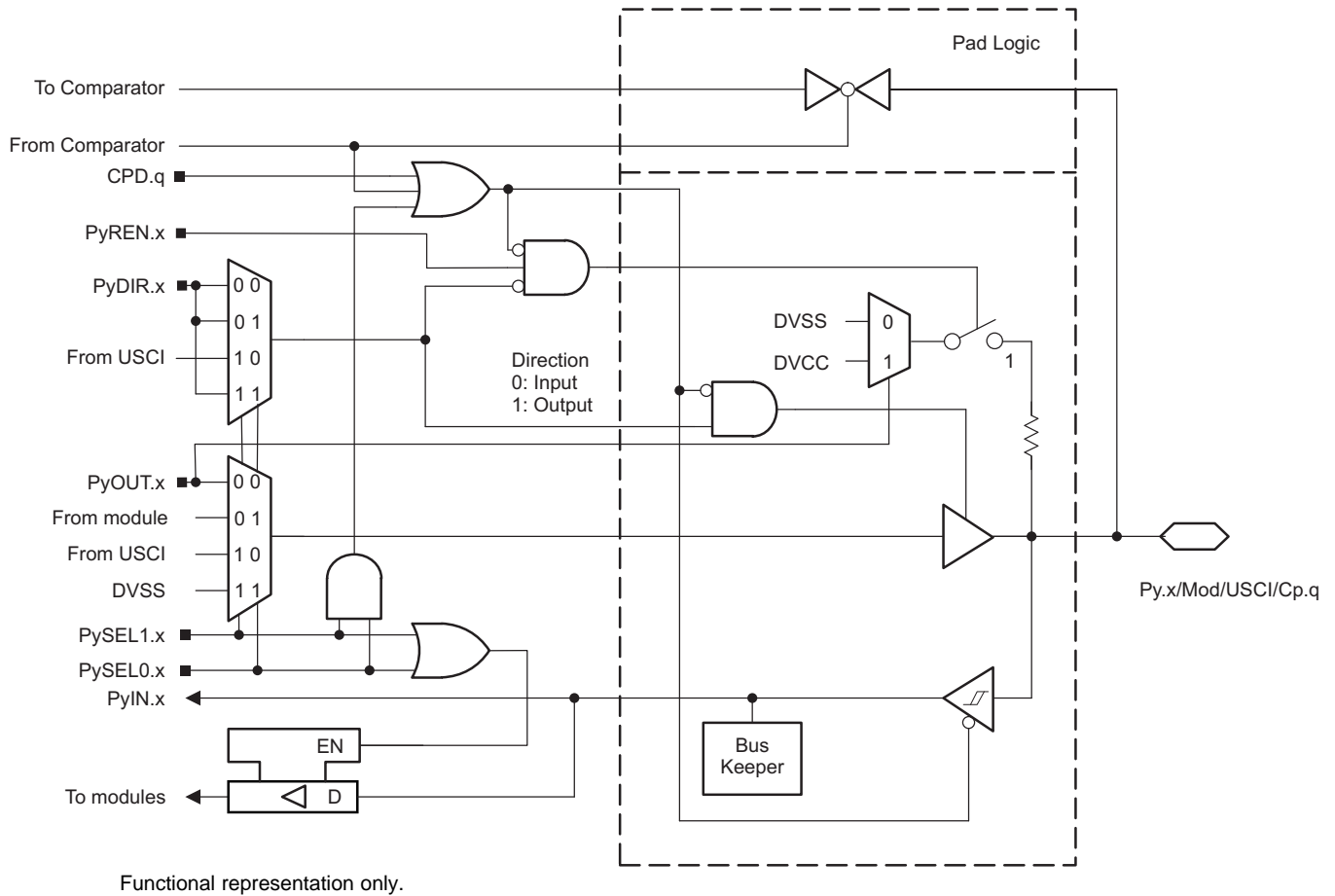

Figure 6-16. Py.x/Mod/USCI/Cp.q Port Schematic

Table 6-80. Port P6 (P6.6 and P6.7) Pin Functions

PIN NAME (P6.x)	x	FUNCTION	CONTROL BITS OR SIGNALS ⁽¹⁾		
			P6DIR.x	P6SEL1.x	P6SEL0.x
P6.6/TA2.3/UCB3SIMO/UCB3SDA/C1.1	6	P6.6 (I/O)	I: 0; O: 1	0	0
		TA2.CCI3A	0	0	1
		TA2.3	1		
		UCB3SIMO/UCB3SDA	X ⁽²⁾	1	0
		C1.1 ^{(3) (4)}	X	1	1
P6.7/TA2.4/UCB3SOMI/UCB3SCL/C1.0	7	P6.7 (I/O)	I: 0; O: 1	0	0
		TA2.CCI4A	0	0	1
		TA2.4	1		
		UCB3SOMI/UCB3SCL	X ⁽²⁾	1	0
		C1.0 ^{(3) (4)}	X	1	1

- (1) X = Don't care
- (2) Direction controlled by eUSCI_B3 module.
- (3) Setting P6SEL1.x and P6SEL0.x disables the output driver and the input Schmitt trigger to prevent parasitic cross currents when applying analog signals.
- (4) Setting the CEPD.q bit of the comparator disables the output driver and the input Schmitt trigger to prevent parasitic cross currents when applying analog signals. Selecting the C1.q input pin to the comparator multiplexer with the CEIPSEL or CEIMSEL bits automatically disables the output driver and input buffer for that pin, regardless of the state of the associated CEPD.q bit.

6.12.19 Port P8 (P8.0 and P8.1) Input/Output With Schmitt Trigger

Figure 6-17 shows the port schematic. Table 6-81 lists the settings to select the port functions.

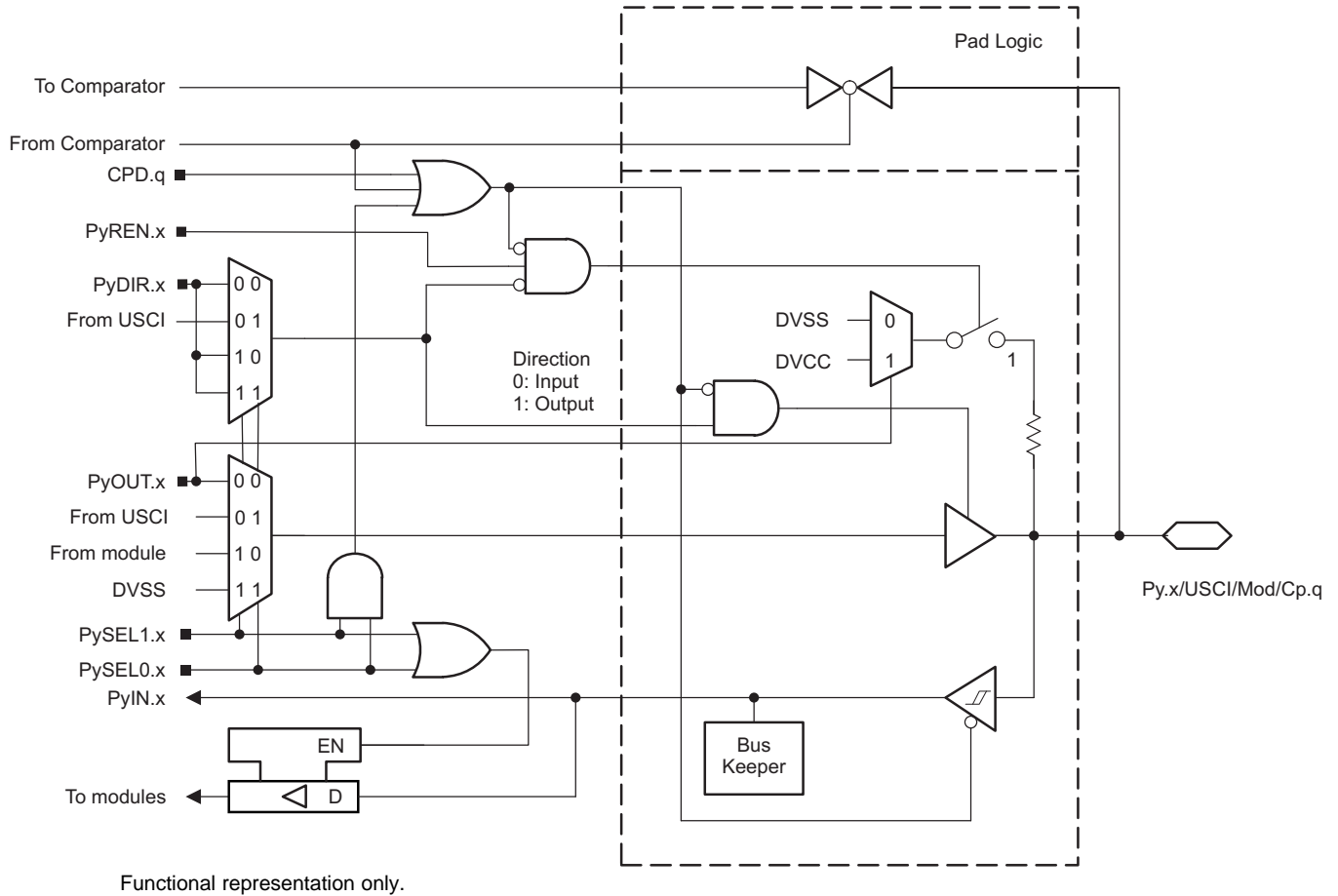

Figure 6-17. Py.x/USCI/Mod/Cp.q Port Schematic

Table 6-81. Port P8 (P8.0 and P8.1) Pin Functions

PIN NAME (P8.x)	x	FUNCTION	CONTROL BITS OR SIGNALS ⁽¹⁾		
			P8DIR.x	P8SEL1.x	P8SEL0.x
P8.0/UCB3STE/TA1.0/C0.1	0	P8.0 (I/O)	I: 0; O: 1	0	0
		UCB3STE	X ⁽²⁾	0	1
		TA1.CCI0A	0	1	0
		TA1.0	1		
		C0.1 ^{(3) (4)}	X	1	1
P8.1/UCB3CLK/TA2.0/C0.0	1	P8.1 (I/O)	I: 0; O: 1	0	0
		UCB3CLK	X ⁽²⁾	0	1
		TA2.CCI0A	0	1	0
		TA2.0	1		
		C0.0 ^{(3) (4)}	X	1	1

- (1) X = Don't care
- (2) Direction controlled by eUSCI_B3 module.
- (3) Setting P8SEL1.x and P8SEL0.x disables the output driver and the input Schmitt trigger to prevent parasitic cross currents when applying analog signals.
- (4) Setting the CEPD.q bit of the comparator disables the output driver and the input Schmitt trigger to prevent parasitic cross currents when applying analog signals. Selecting the C0.q input pin to the comparator multiplexer with the CEIPSEL or CEIMSEL bits automatically disables the output driver and input buffer for that pin, regardless of the state of the associated CEPD.q bit.

6.12.20 Port P10 (P10.4 and P10.5) Input/Output With Schmitt Trigger

Figure 6-18 shows the port schematic. Table 6-82 lists the settings to select the port functions.

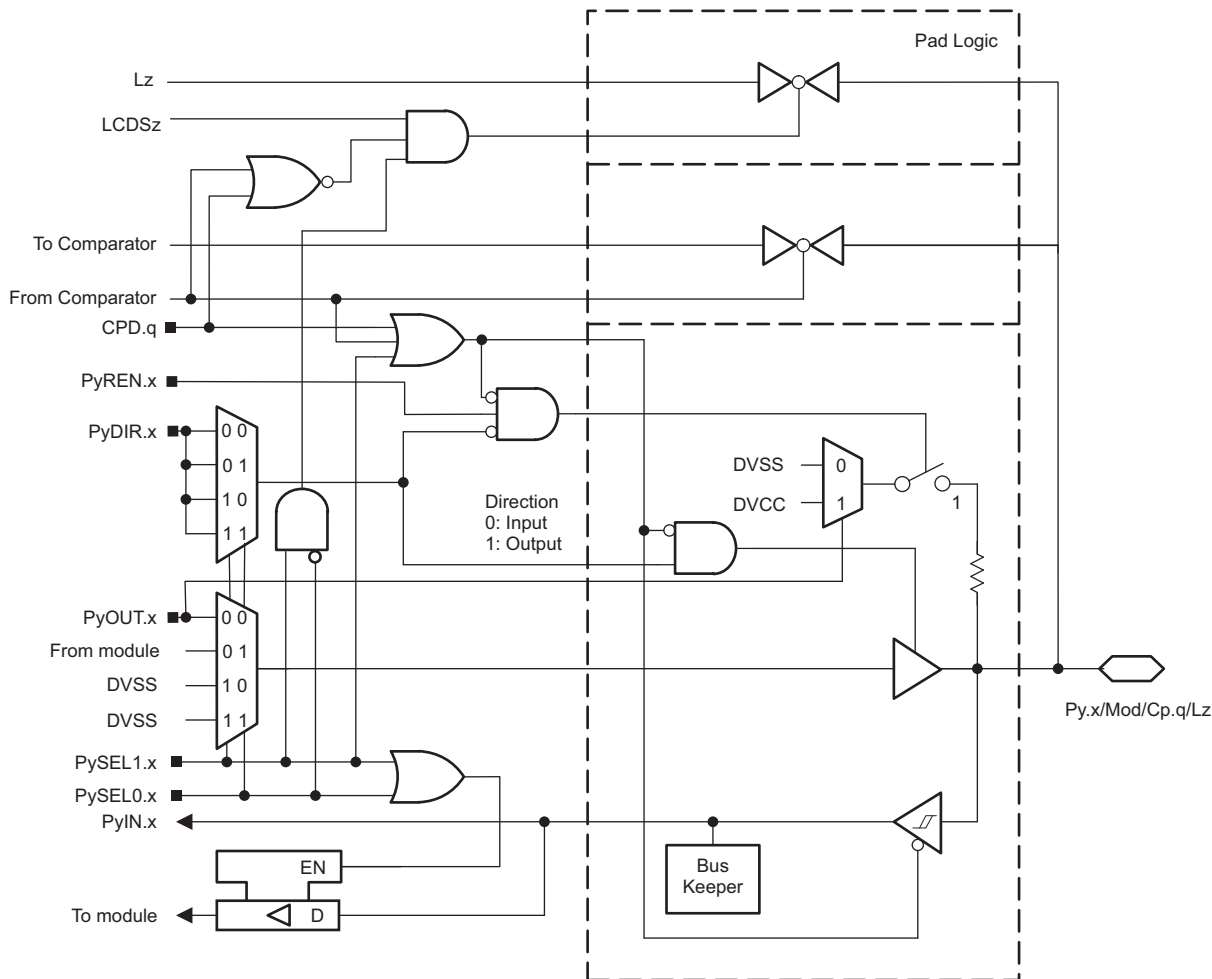

Functional representation only.

Figure 6-18. Py.x/Mod/Cp.q/Lz Port Schematic

Table 6-82. Port P10 (P10.4 and P10.5) Pin Functions

PIN NAME (P10.x)	x	FUNCTION	CONTROL BITS OR SIGNALS ⁽¹⁾		
			P10DIR.x	P10SEL1.x	P10SEL0.x
P10.4/TA3.0/C0.7/L35 ⁽²⁾	4	P10.4 (I/O)	I: 0; O: 1	0	0
		TA3.CCI0A	0	0	1
		TA3.0	1		
		L35 ⁽³⁾	X	1	0
		C0.7 ^{(4) (5)}	X	1	1
P10.5/TA3.1/C0.6/L34 ⁽²⁾	5	P10.5 (I/O)	I: 0; O: 1	0	0
		TA3.CCI1A	0	0	1
		TA3.1	1		
		L34 ⁽³⁾	X	1	0
		C0.6 ^{(4) (5)}	X	1	1

- (1) X = Don't care
- (2) Not available on the 64-pin RGC package.
- (3) Setting the PSEL1.x and PSEL0.x bits to 10 disables both the output driver and input Schmitt trigger to prevent leakage when analog signals are applied.
- (4) Setting P10SEL1.x and P10SEL0.x disables the output driver and the input Schmitt trigger to prevent parasitic cross currents when applying analog signals.
- (5) Setting the CEPD.q bit of the comparator disables the output driver and the input Schmitt trigger to prevent parasitic cross currents when applying analog signals. Selecting the C0.q input pin to the comparator multiplexer with the CEIPSEL or CEIMSEL bits automatically disables the output driver and input buffer for that pin, regardless of the state of the associated CEPD.q bit.

6.12.21 Port P7 (P7.4 to P7.7) Input/Output With Schmitt Trigger

Figure 6-19 shows the port schematic. Table 6-83 lists the settings to select the port functions.

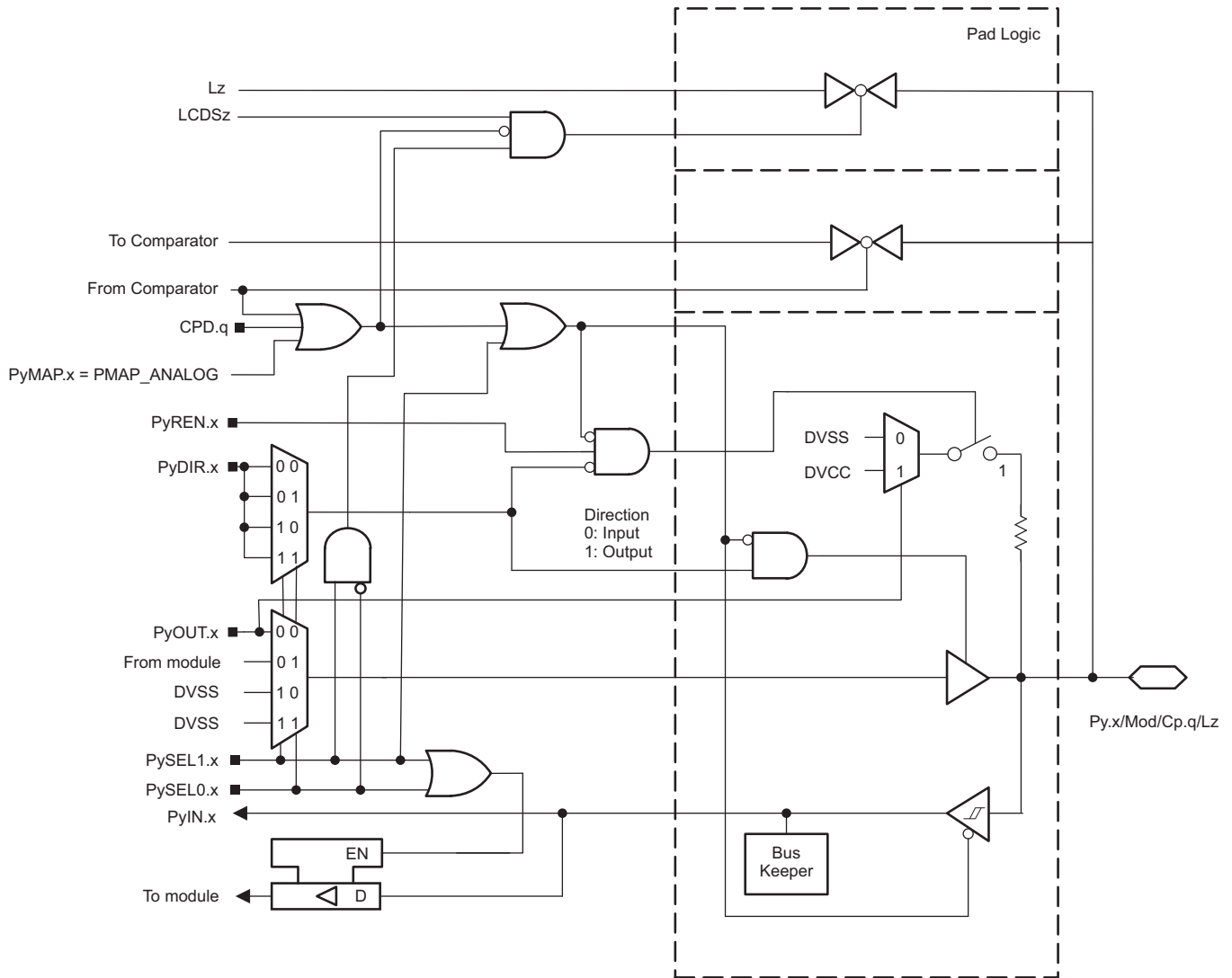

Functional representation only.

Figure 6-19. Py.x/Mod/Cp.q/Lz Port Schematic

Table 6-83. Port P7 (P7.4 to P7.7) Pin Functions

PIN NAME (P7.x)	x	FUNCTION	CONTROL BITS OR SIGNALS ⁽¹⁾			
			P7DIR.x	P7SEL1.x	P7SEL0.x	P7MAPx
P7.4/PM_TA1.4/C0.5/L31 ⁽²⁾	4	P7.4 (I/O)	I: 0; O: 1	0	0	X
		TA1.CCI4A	0	0	1	default
		TA1.4	1			
		L31 ⁽³⁾	X	1	0	X
		C0.5 ^{(4) (5) (6)}	X	1	1	X
P7.5/PM_TA1.3/C0.4/L30 ⁽²⁾	5	P7.5 (I/O)	I: 0; O: 1	0	0	X
		TA1.CCI3A	0	0	1	default
		TA1.3	1			
		L30 ⁽³⁾	X	1	0	X
		C0.4 ^{(4) (5) (6)}	X	1	1	X
P7.6/PM_TA1.2/C0.3/L29 ⁽²⁾	6	P7.6 (I/O)	I: 0; O: 1	0	0	X
		TA1.CCI2A	0	0	1	default
		TA1.2	1			
		L29 ⁽³⁾	X	1	0	X
		C0.3 ^{(4) (5) (6)}	X	1	1	X
P7.7/PM_TA1.1/C0.2/L28 ⁽²⁾	7	P7.7 (I/O)	I: 0; O: 1	0	0	X
		TA1.CCI1A	0	0	1	default
		TA1.1	1			
		L28 ⁽³⁾	X	1	0	X
		C0.2 ^{(4) (5) (6)}	X	1	1	X

- (1) X = Don't care
- (2) Not available on the 64-pin RGC package.
- (3) Setting the PSEL1.x and PSEL0.x bits to 10 disables both the output driver and input Schmitt trigger to prevent leakage when analog signals are applied.
- (4) Setting P7SEL1.x and P7SEL0.x disables the output driver and the input Schmitt trigger to prevent parasitic cross currents when applying analog signals.
- (5) Setting the CEPD.q bit of the comparator disables the output driver and the input Schmitt trigger to prevent parasitic cross currents when applying analog signals. Selecting the C0.q input pin to the comparator multiplexer with the CEIPSEL or CEIMSEL bits automatically disables the output driver and input buffer for that pin, regardless of the state of the associated CEPD.q bit.
- (6) Setting P7MAPx = PM_ANALOG disables the output driver and the input Schmitt trigger independent of P7SEL1.x and P7SEL0.x settings.

6.12.22 Port PJ (PJ.0 and PJ.1) Input/Output With Schmitt Trigger

Figure 6-20 and Figure 6-21 show the port schematics. Table 6-84 lists the settings to select the port functions.

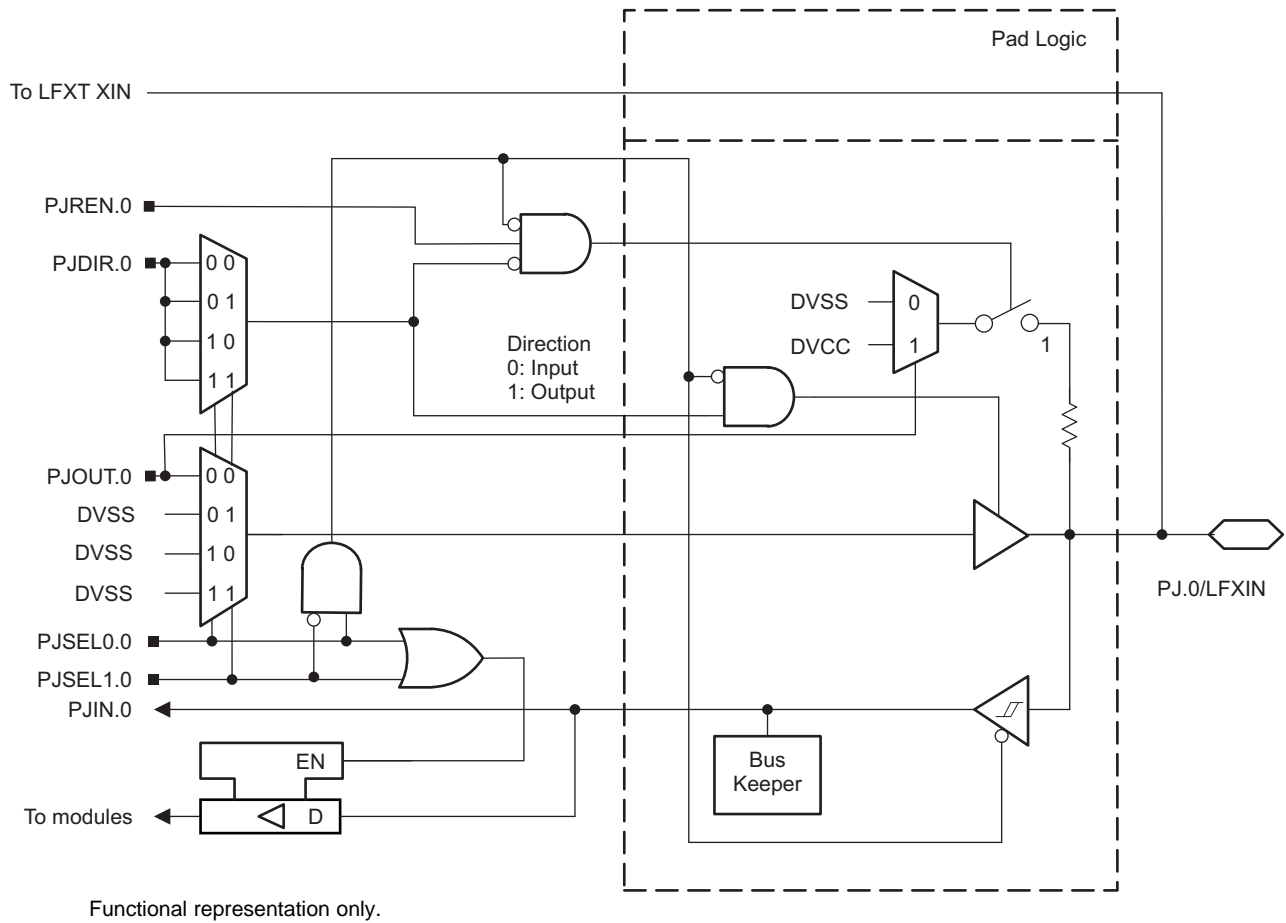
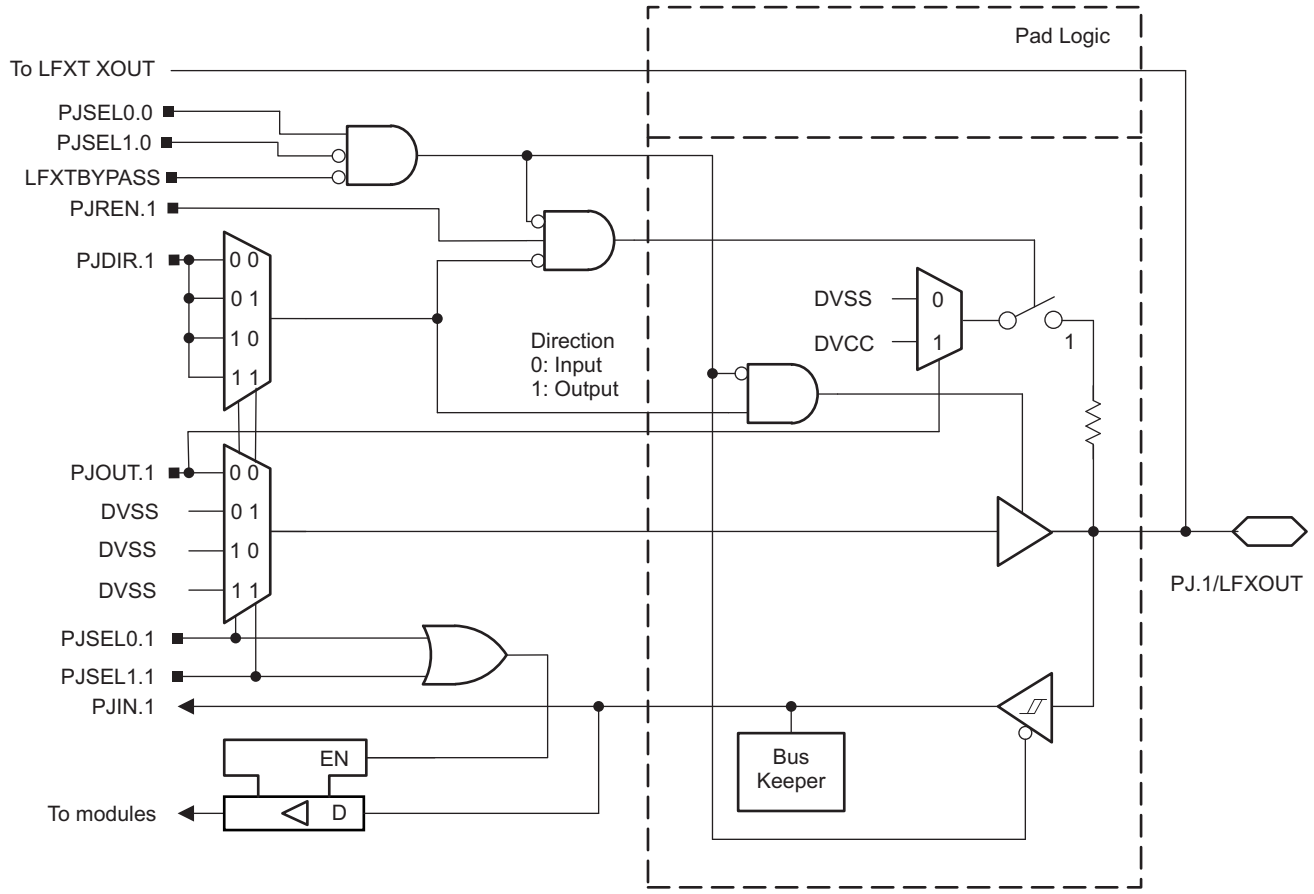

Figure 6-20. Port PJ (PJ.0) Port Schematic



Functional representation only.

Figure 6-21. Port PJ (PJ.1) Port Schematic

Table 6-84. Port PJ (PJ.0 and PJ.1) Pin Functions

PIN NAME (PJ.x)	x	FUNCTION	CONTROL BITS OR SIGNALS ⁽¹⁾					
			PJDIR.x	PJSEL1.1	PJSEL0.1	PJSEL1.0	PJSEL0.0	LFXT BYPASS
PJ.0/LFXIN	0	PJ.0 (I/O)	I: 0; O: 1	X	X	0	0	X
		N/A	0	X	X	1	X	X
		DVSS	1					
		LFXIN crystal mode ⁽²⁾	X	X	X	0	1	0
		LFXIN bypass mode ⁽²⁾	X	X	X	0	1	1
PJ.1/LFXOUT	1	PJ.1 (I/O)	I: 0; O: 1	0	0	0	0	0
						1	X	
						X	X	
		N/A	0	See ⁽⁴⁾	See ⁽⁴⁾	0	0	0
						1	X	
						X	X	
		DVSS	1	See ⁽⁴⁾	See ⁽⁴⁾	0	0	0
						1	X	
						X	X	
LFXOUT crystal mode ⁽²⁾	X	X	X	0	1	0		

(1) X = Don't care

(2) Setting PJSEL1.0 = 0 and PJSEL0.0 = 1 causes the general-purpose I/O to be disabled. When LFXTBYPASS = 0, PJ.0 and PJ.1 are configured for crystal operation and PJSEL1.1 and PJSEL0.1 are don't care. When LFXTBYPASS = 1, PJ.0 is configured for bypass operation and PJ.1 is configured as general-purpose I/O.

(3) When PJ.0 is configured in bypass mode, PJ.1 is configured as general-purpose I/O.

(4) With PJSEL0.1 = 1 or PJSEL1.1 = 1 the general-purpose I/O functionality is disabled. No input function is available. When configured as output, the pin is actively pulled to zero.

6.12.23 Port PJ (PJ.2 and PJ.3) Input/Output With Schmitt Trigger

Figure 6-23 and Figure 6-22 show the port schematics. Table 6-85 lists the settings to select the port functions.

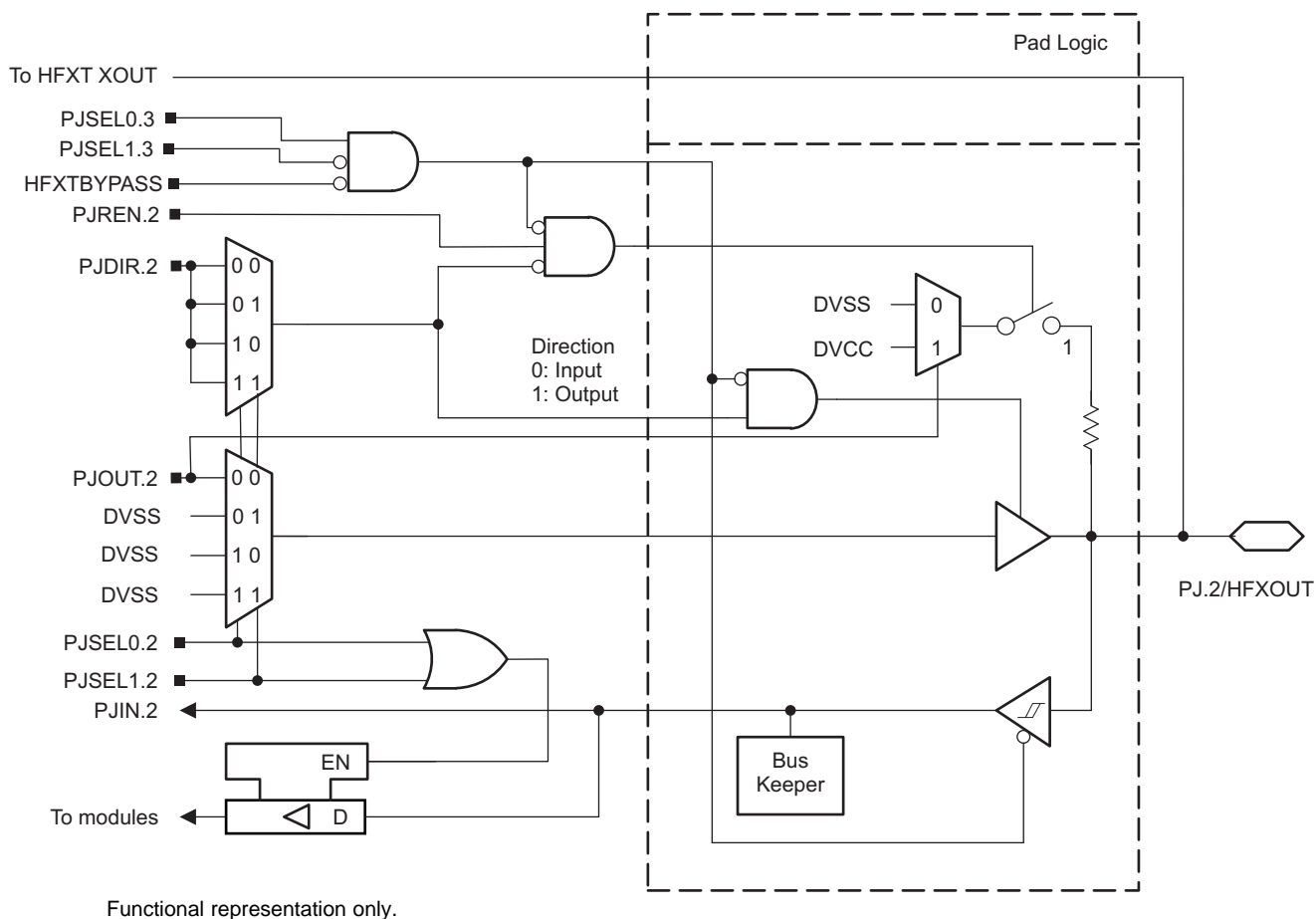

Functional representation only.

Figure 6-22. Port PJ (PJ.2) Port Schematic

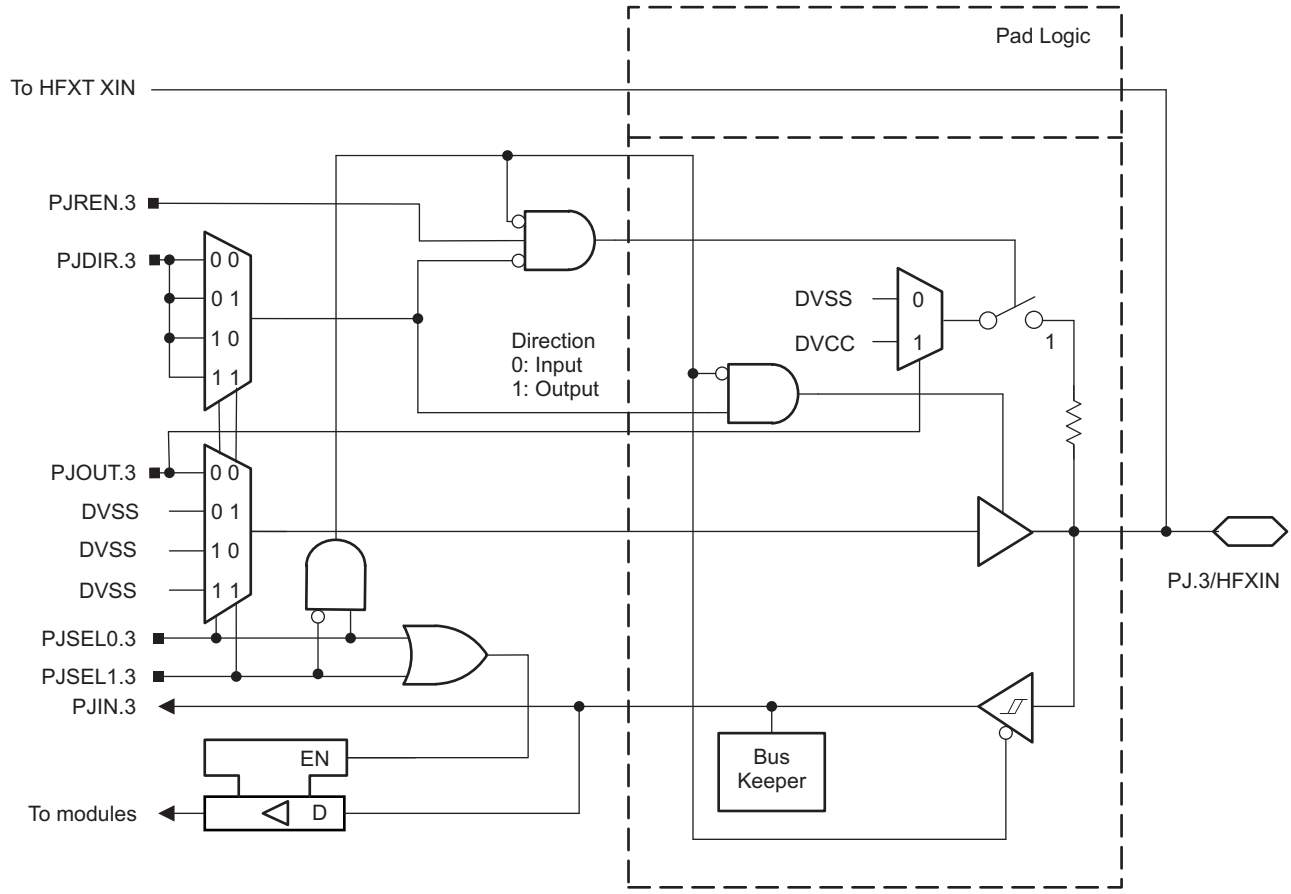

Functional representation only.

Figure 6-23. Port PJ (PJ.3) Port Schematic

Table 6-85. Port PJ (PJ.2 and PJ.3) Pin Functions

PIN NAME (PJ.x)	x	FUNCTION	CONTROL BITS OR SIGNALS ⁽¹⁾					HFXT BYPASS
			PJDIR.x	PJSEL1.2	PJSEL0.2	PJSEL1.3	PJSEL0.3	
PJ.3/HFXIN	3	PJ.3 (I/O)	I: 0; O: 1	X	X	0	0	X
		N/A	0	X	X	1	X	X
		DVSS	1					
		HFXIN crystal mode ⁽²⁾	X	X	X	0	1	0
		HFXIN bypass mode ⁽²⁾	X	X	X	0	1	1
PJ.2/HFXOUT	2	PJ.2 (I/O)	I: 0; O: 1	0	0	0	0	0
						1	X	
						X	X	1 ⁽³⁾
		N/A	0	See ⁽⁴⁾	See ⁽⁴⁾	0	0	0
						1	X	
						X	X	1 ⁽³⁾
		DVSS	1	See ⁽⁴⁾	See ⁽⁴⁾	0	0	0
						1	X	
						X	X	1 ⁽³⁾
HFXOUT crystal mode ⁽²⁾	X	X	X	0	1	0		

- (1) X = Don't care
- (2) Setting PJSEL1.3 = 0 and PJSEL0.3 = 1 causes the general-purpose I/O to be disabled. When HFXTBYPASS = 0, PJ.2 and PJ.3 are configured for crystal operation and PJSEL1.2 and PJSEL0.2 are don't care. When HFXTBYPASS = 1, PJ.3 is configured for bypass operation and PJ.2 is configured as general-purpose I/O.
- (3) When PJ.3 is configured in bypass mode, PJ.2 is configured as general-purpose I/O.
- (4) With PJSEL0.2 = 1 or PJSEL1.2 = 1 the general-purpose I/O functionality is disabled. No input function is available. When configured as output, the pin is actively pulled to zero.

6.12.24 Port PJ (PJ.4 and PJ.5) Input/Output With Schmitt Trigger

Table 6-86 lists the settings to select the port functions.

Table 6-86. Port PJ (PJ.4 to PJ.5) Pin Functions

PIN NAME (P7.x)	x	FUNCTION	CONTROL BITS OR SIGNALS ⁽¹⁾				SWJ MODE OF OPERATION ⁽¹⁾
			PJDIR.x	PJSEL1.x	PJSEL0.x	PJMAPx	
PJ.4/TDI ⁽²⁾	4	PJ.4 (I/O)	I: 0; O: 1	0	0	X	X
		TDI	X	0	1	default ⁽³⁾	JTAG (4 wire)
		DVcc					SWD (2 wire)
		DVcc	X	1	X	X	X
PJ.5/TDO/SWO ^{(4), (5)}	5	PJ.5 (I/O)	I: 0; O: 1	0	0	X	X
		TDO	X	0	1	default ⁽³⁾	JTAG (4 wire)
		SWO					SWD (2 wire)
		Hi-Z	X	1	X	X	X

(1) X indicates that the value of the control signal or mode of operation has no effect on the functionality.

(2) This pin is internally pulled up if PJSEL0 is 1.

(3) The 'default' value in the table indicates the functionality that is selected whenever a hard reset (or higher class reset) occurs.

(4) This pin is has no internal pull feature. If used in User IO mode or left unused, it must be pulled to GND through an external pulldown resistor.

(5) After any hard reset (or higher class reset), this pin returns to TDO functionality with the SWJ in JTAG (4 wire) mode of operation. If used as a User IO, it reflects the value of the external pullup until the PJSELx bits are reconfigured to the value 00.

6.12.25 Ports SWCLKTCK and SWDIOTMS With Schmitt Trigger

Table 6-87 lists the SWCLKTCK and SWDIOTMS pin functions.

Table 6-87. Ports SWCLKTCK and SWDIOTMS Pin Functions

PIN NAME	FUNCTION	SWJ MODE OF OPERATION
SWCLKTCK ⁽¹⁾	TCK (input)	JTAG (4 wire)
	SWCLK (input)	SWD (2 wire)
SWDIOTMS ⁽²⁾	TMS (input)	JTAG (4 wire)
	SWDIO (I/O)	SWD (2 wire)

(1) This pin is internally pulled to DV_{SS}.

(2) This pin is internal pulled to DV_{CC}.

6.13 Device Descriptors (TLV)

Table 6-88 lists the Device IDs of the MSP432P4x1xl devices.

Table 6-88. Device IDs

DEVICE	DEVICE ID
MSP432P4111IPZ	0000A010h
MSP432P411YIPZ	0000A012h
MSP432P411VIPZ	0000A016h
MSP432P4011IRGC	0000A019h
MSP432P401YIRGC	0000A01Bh
MSP432P401VIRGC	0000A01Fh

Table 6-89 lists the contents of the device descriptor tag-length-value (TLV) structure for MSP432P4x1xl devices.

Table 6-89. Device Descriptors⁽¹⁾

	DESCRIPTION	ADDRESS	VALUE
	TLV checksum	00201000h	Per unit
Info Block	Device info tag	00201004h	0000000Bh
	Device info length	00201008h	00000004h
	Device ID	0020100Ch	See Table 6-88.
	Hardware revision	00201010h	00000041h
	Boot code revision	00201014h	00430044h
	ROM driver library revision	00201018h	03400011h
	Die Record	Die record tag	0020101Ch
Die record length		00201020h	00000008h
Die X position		00201024h	Per unit
Die Y position		00201028h	Per unit
Wafer ID		0020102Ch	Per unit
Lot ID		00201030h	Per unit
Reserved		00201034h	Per unit
Reserved		00201038h	Per unit
Reserved		0020103Ch	Per unit
Test results		00201040h	FFFFFFFFh

(1) Per unit = the contents can differ from device to device

Table 6-89. Device Descriptors⁽¹⁾ (continued)

	DESCRIPTION	ADDRESS	VALUE
Clock System Calibration	Clock system calibration tag	00201044h	00000003h
	Clock system calibration length	00201048h	00000010h
	DCO IR mode: frequency calibration for DCORSEL 0 to 4	0020104Ch	Per unit
	DCO IR mode: frequency calibration for DCORSEL 5	00201050h	Per unit
	Reserved	00201054h	000000C0h
	Reserved	00201058h	000002C0h
	Reserved	0020105Ch	0000002Ah
	Reserved	00201060h	000002C0h
	DCO IR mode: DCO constant (K) for DCORSEL 0 to 4	00201064h	Per unit
	DCO IR mode: DCO constant (K) for DCORSEL 5	00201068h	Per unit
	DCO ER mode: frequency calibration for DCORSEL 0 to 4	0020106Ch	Per unit
	DCO ER mode: frequency calibration for DCORSEL 5	00201070h	Per unit
	Reserved	00201074h	000000B4h
	Reserved	00201078h	000002C0h
	Reserved	0020107Ch	00000028h
	Reserved	00201080h	000002C0h
	DCO ER mode: DCO constant (K) for DCORSEL 0 to 4	00201084h	Per unit
	DCO ER mode: DCO constant (K) for DCORSEL 5	00201088h	Per unit
	ADC14 Calibration	ADC14 calibration tag	0020108Ch
ADC14 calibration length		00201090h	00000018h
Reserved		00201094h	FFFFFFFFh
Reserved		00201098h	FFFFFFFFh
Reserved		0020109Ch	FFFFFFFFh
Reserved		002010A0h	FFFFFFFFh
Reserved		002010A4h	FFFFFFFFh
Reserved		002010A8h	FFFFFFFFh
Reserved		002010ACh	FFFFFFFFh
Reserved		002010B0h	FFFFFFFFh
Reserved		002010B4h	FFFFFFFFh
Reserved		002010B8h	FFFFFFFFh
Reserved		002010BCh	FFFFFFFFh
Reserved		002010C0h	FFFFFFFFh
Reserved		002010C4h	FFFFFFFFh
Reserved		002010C8h	FFFFFFFFh
Reserved		002010CCh	FFFFFFFFh
Reserved		002010D0h	FFFFFFFFh
Reserved		002010D4h	FFFFFFFFh
Reserved		002010D8h	FFFFFFFFh
ADC 1.2-V reference temperature sensor 30°C		002010DCh	Per unit
ADC 1.2-V reference temperature sensor 85°C		002010E0h	Per unit
ADC 1.45-V reference temperature sensor 30°C		002010E4h	Per unit
ADC 1.45-V reference temperature sensor 85°C		002010E8h	Per unit
ADC 2.5-V reference temperature sensor 30°C		002010ECh	Per unit
ADC 2.5-V reference temperature sensor 85°C		002010F0h	Per unit
REF Calibration	REF calibration tag	002010F4h	00000008h
	REF calibration length	002010F8h	00000003h
	Reserved	002010FCh	FFFFFFFFh
	Reserved	00201100h	FFFFFFFFh
	Reserved	00201104h	FFFFFFFFh

Table 6-89. Device Descriptors⁽¹⁾ (continued)

	DESCRIPTION	ADDRESS	VALUE	
Flash Info	Flash info tag	00201108h	00000004h	
	Flash info length	0020110Ch	00000002h	
	Flash maximum programming pulses	00201110h	00000005h	
	Flash maximum erase pulses	00201114h	0000014Eh	
Random Number	128-bit random number tag	00201118h	0000000Dh	
	128-bit random number length	0020111Ch	00000004h	
	128-bit random number ⁽²⁾		00201120h	Per unit
			00201124h	Per unit
			00201128h	Per unit
		0020112Ch	Per unit	
BSL Configuration	BSL configuration tag	00201130h	0000000Fh	
	BSL configuration length	00201134h	00000004h	
	BSL peripheral interface selection	00201138h	FFC2D0C0h	
	BSL port interface configuration for UART	0020113Ch	FCFFFDA0h	
	BSL port interface configuration for SPI	00201140h	F0FF9770h	
	BSL port interface configuration for I2C	00201144h	FCFFFF72h	
TLV End	TLV end word	00201148h	0BD0E11Dh	
	Reserved	0020114Ch to 00201FFFh	FFFFFFFFh	

(2) 128-bit random number: The random number is generated during production test using the CryptGenRandom() function from Microsoft®

6.14 Identification

6.14.1 Revision Identification

The device revision information is shown as part of the top-side marking on the device package. The device-specific errata sheet describes these markings. For links to the errata sheets for the devices in this data sheet, see [Section 8.4](#).

The hardware revision is also stored in the Device Descriptor structure in the Info Block section. For details on this value, see the Hardware Revision entry in the Device Descriptor structure (see [Section 6.13](#)).

6.14.2 Device Identification

The device type can be identified from the top-side marking on the device package. The device-specific errata sheet describes these markings. For links to the errata sheets for the devices in this data sheet, see [Section 8.4](#).

A device identification value is also stored in the Device Descriptor structure in the Info Block section. For details on this value, see the Device ID entry in the Device Descriptor structure (see [Section 6.13](#)).

6.14.3 Arm Cortex-M4F ROM Table Based Part Number

MSP432P4xx family of devices incorporate a part number for the device in addition to the device IDs specified in the device descriptors (TLV) for the IDEs to recognize the device. This section describes how this information is organized on the device.

The IEEE 1149.1 standard defines the use of a IDCODE register in the JTAG chain that provides the fields in [Table 6-90](#)

Table 6-90. Structure of Device Identification Code

BIT POSITION	FIELD DESCRIPTION
31-28	Version
27-12	Part Number of the device
11-1	Manufacturer Identity
0	Reserved (Always tied to 1)

On MSP432P4xx devices all the fields in [Table 6-90](#) are implemented on the Arm Cortex-M4 ROM table. The part number can be read by the IDE tools to determine the device with which it is working.

[Figure 6-24](#) shows the Peripheral ID register bit descriptions according to the Arm Cortex-M4 specifications.

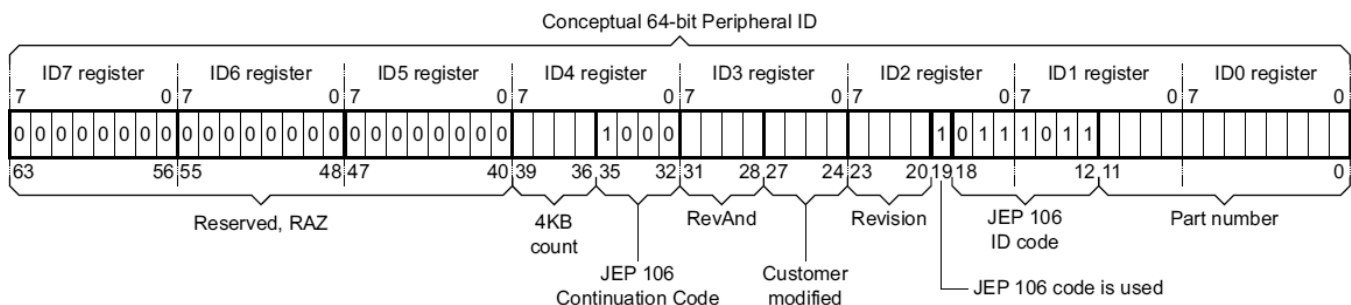

Figure 6-24. Arm Cortex-M4 Peripheral ID Register Description

See the *Arm Debug Interface V5 Architecture Specification* for bit-level details on the Arm Cortex-M4 Peripheral ID registers.

From Figure 6-24 it is evident that a one-to-one mapping is not possible for the following fields from Table 6-90

1. Version: IEEE 1149.1 defines a 4-bit field. The CoreSight™ compliant PID registers have 4 bits each for Revision (major revision) and RevAnd (minor revision).
2. Part Number: IEEE 1149.1 defines a 16-bit entity. The PID registers in the ROM table have only 12 bits reserved for this purpose (part number in the PID1 and PID0 registers).

For the MSP432P4xx family, the Revision and RevAnd fields are the major and minor revisions. Also the 4-bit customer-modified field extends the part number to 16 bits by accommodating all the fields needed by IEEE 1149.1 into the ROM table.

The ROM table with IEEE 1149.1-complaint device IDCODE for MSP432P4x1x device example is 0000-1011-1011-0100-1101-0000-0010-1111 (see Figure 6-25).

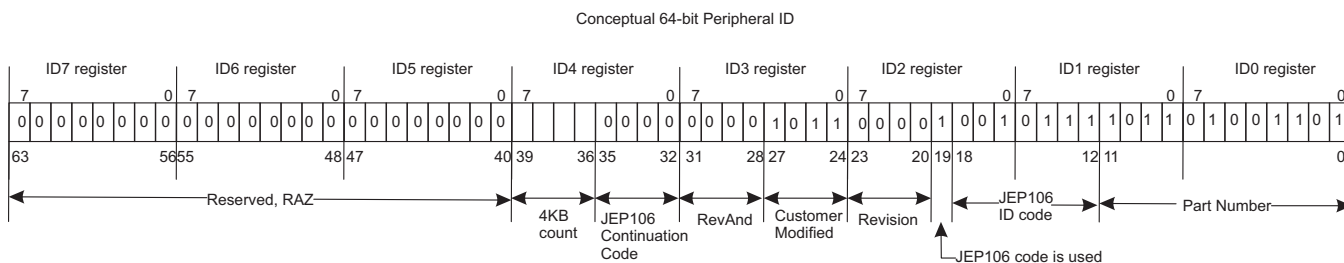

Bits with no value shown are IMPLEMENTATION DEFINED.
Other bits not shown as Reserved are for an implementation designed by Arm Limited.

Figure 6-25. ROM PID Entries for MSP432P4x1x Device

7 Applications, Implementation, and Layout

NOTE

Information in the following Applications section is not part of the TI component specification, and TI does not warrant its accuracy or completeness. TI's customers are responsible for determining suitability of components for their purposes. Customers must validate and test their design implementation to confirm system functionality.

7.1 Device Connection and Layout Fundamentals

This section describes the recommended guidelines when designing with the MSP432 microcontrollers. These guidelines are to make sure that the device has proper connections for powering, programming, debugging, and optimum analog performance.

7.1.1 Power Supply Decoupling and Bulk Capacitors

TI recommends connecting a combination of a 4.7- μ F plus a 100-nF low-ESR ceramic decoupling capacitor to each AVCC and DVCC pin (see Figure 7-1). Higher-value capacitors may be used but can affect supply rail ramp-up time. Decoupling capacitors must be placed as close as possible to the pins that they decouple (within a few millimeters). Additionally, TI recommends separated grounds with a single-point connection for better noise isolation from digital-to-analog circuits on the board and to achieve high analog accuracy.

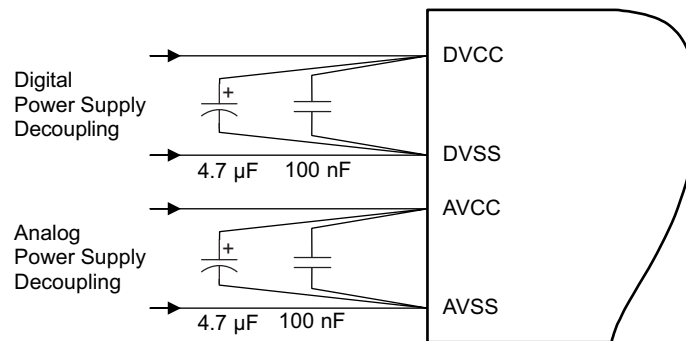

Figure 7-1. Power Supply Decoupling

7.1.2 External Oscillator

The device supports a low-frequency crystal (32.768 kHz) on the LFXT pins and a high-frequency crystal on the HFXT pins. External bypass capacitors for the crystal oscillator pins are required.

It is also possible to apply digital clock signals to the LFXIN and HFXIN input pins that meet the specifications of the respective oscillator if the appropriate LFXTBYPASS or HFXTBYPASS mode is selected. In this case, the associated LFXOUT and HFXOUT pins can be used for other purposes.

Figure 7-2 shows a typical connection diagram.

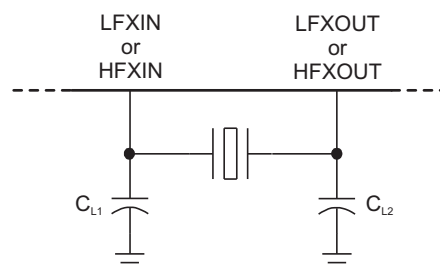

Figure 7-2. Typical Crystal Connection

See [MSP430 32-kHz Crystal Oscillators](#) for more information on selecting, testing, and designing a crystal oscillator with the MSP432 devices.

7.1.3 General Layout Recommendations

- Use proper grounding and short traces for the external crystal to reduce parasitic capacitance. See [MSP430 32-kHz Crystal Oscillators](#) for recommended layout guidelines.
- Use specified bypass capacitors on DVCC, AVCC, and reference pins, if used.
- Do not route any high-frequency signal close to an analog signal line. For example, keep digital switching signals such as PWM or JTAG signals away from the oscillator circuit.
- Design in proper ESD level protection to protect the device from unintended high-voltage electrostatic discharge. See [MSP430 System-Level ESD Considerations](#) for guidelines.

7.1.4 Do's and Don'ts

TI recommends powering AVCC and DVCC pins from the same source. At a minimum, during power up, power down, and device operation, the voltage difference between AVCC and DVCC must not exceed the limits specified in [Section 5.1](#). Exceeding the specified limits may cause malfunction of the device.

7.2 Peripheral and Interface-Specific Design Information

7.2.1 Precision ADC Peripheral

7.2.1.1 Partial Schematic

[Figure 7-3](#) shows the recommended circuit for grounding and noise reduction.

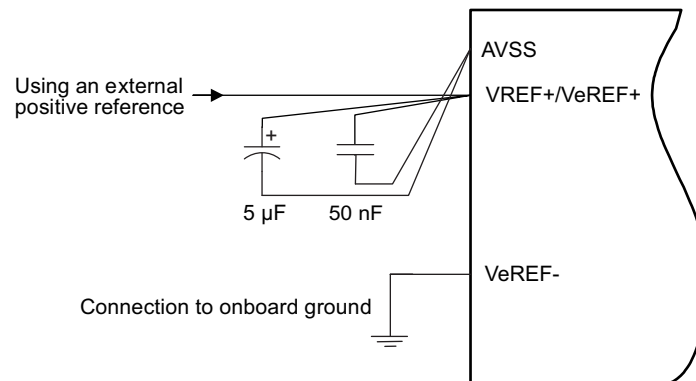

Figure 7-3. Precision ADC Grounding and Noise Considerations

7.2.1.2 Design Requirements

As with any high-resolution ADC, follow appropriate PCB layout and grounding techniques to eliminate ground loops, unwanted parasitic effects, and noise.

Ground loops are formed when return current from the ADC flows through paths that are common with other analog or digital circuitry. If care is not taken, this current can generate small unwanted offset voltages that can add to or subtract from the reference or input voltages of the ADC. The general guidelines in [Section 7.1.1](#) combined with the connections shown in [Section 7.2.1.1](#) prevent this.

In addition to grounding, ripple and noise spikes on the power-supply lines that are caused by digital switching or switching power supplies can corrupt the conversion result. TI recommends a noise-free design using separate analog and digital ground planes with a single-point connection to achieve high accuracy.

[Figure 7-3](#) shows the recommended decoupling circuit when an external voltage reference is used.

The reference voltage must be a stable voltage for accurate measurements. The capacitor values that are selected in the general guidelines filter out the high- and low-frequency ripple before the reference voltage enters the device. In this case, the 5- μ F capacitor is used to buffer the reference pin and filter any low-frequency ripple. A 50-nF bypass capacitor is used to filter out any high-frequency noise.

7.2.1.3 Layout Guidelines

Place components that are shown in the partial schematic (see [Figure 7-3](#)) as close as possible to the respective device pins. Avoid long traces, because they add additional parasitic capacitance, inductance, and resistance on the signal.

Avoid routing analog input signals close to a high-frequency pin (for example, a high-frequency PWM), because the high-frequency switching can be coupled into the analog signal.

If differential mode is used for the Precision ADC, the analog differential input signals must be routed closely together to minimize the effect of noise on the resulting signal.

8 Device and Documentation Support

8.1 Getting Started

For more information on the MSP432 family of devices and the tools and libraries that are available to help with your development, visit [SimpleLink™ Arm® MSP432 microcontrollers](#).

8.2 Device Nomenclature

To designate the stages in the product development cycle, TI assigns prefixes to the part numbers of all MSP MCU devices. Each MSP MCU commercial family member has one of two prefixes: MSP or XMS. These prefixes represent evolutionary stages of product development from engineering prototypes (XMS) through fully qualified production devices (MSP).

XMS – Experimental device that is not necessarily representative of the final device's electrical specifications

MSP – Fully qualified production device

XMS devices are shipped against the following disclaimer:

"Developmental product is intended for internal evaluation purposes."

MSP devices have been characterized fully, and the quality and reliability of the device have been demonstrated fully. TI's standard warranty applies.

Predictions show that prototype devices (XMS) have a greater failure rate than the standard production devices. TI recommends that these devices not be used in any production system because their expected end-use failure rate still is undefined. Only qualified production devices are to be used.

TI device nomenclature also includes a suffix with the device family name. This suffix indicates the temperature range, package type, and distribution format. [Figure 8-1](#) shows a legend for reading the complete device name.

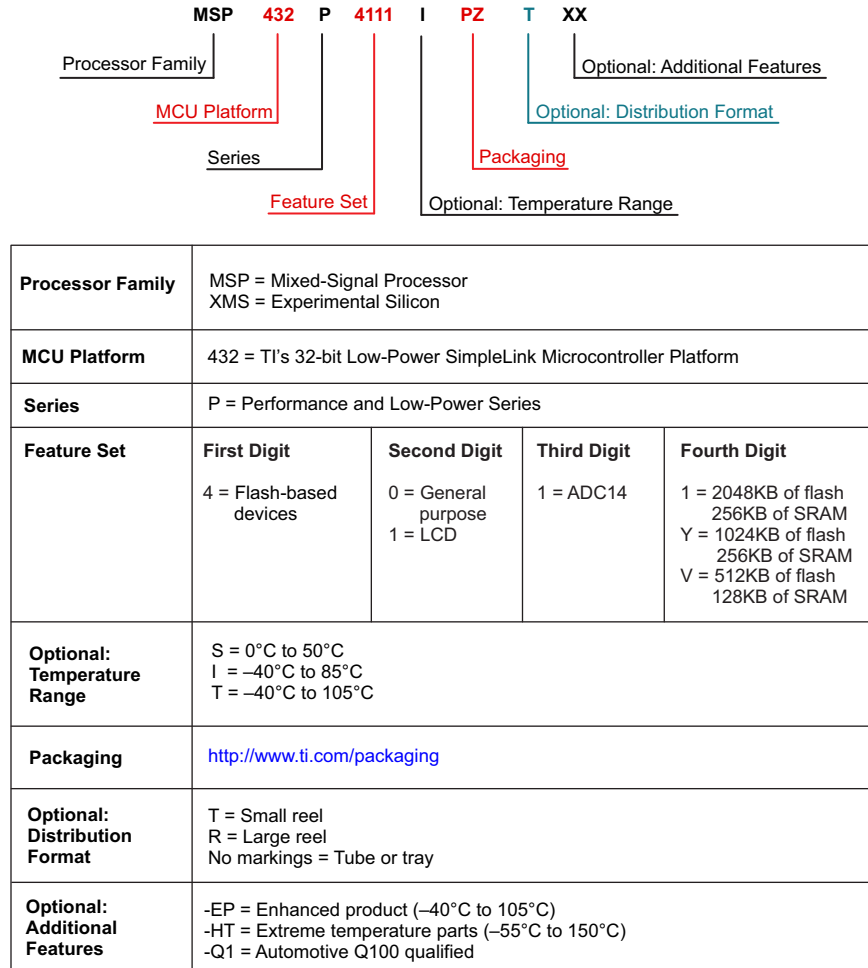

Figure 8-1. Device Nomenclature

8.3 Tools and Software

All MSP microcontrollers are supported by a wide variety of software and hardware development tools. Tools are available from TI and various third parties. See them all at [SimpleLink™ Arm® MSP432 microcontrollers](#).

Table 8-1 lists the supported debug features. See the [Code Composer Studio™ IDE for SimpleLink™ MSP432™ MCUs User's Guide](#) for details on the available hardware features.

Table 8-1. Hardware Debug Features

FAMILY	JTAG	SWD	NUMBER OF BREAKPOINTS	ITM	DWT	FPB
MSP432P4xx	Yes	Yes	4	Yes	Yes	Yes

EnergyTrace technology is supported with Code Composer Studio version 6.0 and newer. It requires specialized debugger circuitry, which is supported with the second-generation onboard eZ-FET flash emulation tool and second-generation stand-alone MSP-FET JTAG emulator.

Design Kits and Evaluation Modules

MSP432P4111 LaunchPad Development Kit The MSP432P4111 LaunchPad development kit enables you to develop high-performance applications that benefit from low-power operation. The kit features the MSP432P4111, which includes a 48-MHz Arm Cortex-M4F, 100- μ A/MHz active power, and 820-nA RTC operation, 14-bit 1-Msps differential SAR ADC, and an AES256 accelerator.

100-Pin Target Development Board for MSP432P4x MCUs The MSP-TS432PZ100 is a stand-alone ZIF socket target board used to program and debug the MSP432 in-system through the JTAG interface or the Serial Wire Debug (SWD 2-wire JTAG) protocol. The development board supports all MSP432P4x1x flash parts in a 100-pin LQFP package (TI package code: PZ).

Software

SimpleLink MSP432™ Software Development Kit (SDK) The SimpleLink MSP432 SDK is a comprehensive software package that enables engineers to quickly develop highly functional applications on MSP432 MCUs. The SDK comprises multiple compatible software components including RTOS, drivers, middleware, and examples of how to use these components together. Examples demonstrate each functional area and each supported device and can be a starting point for your own projects. The SimpleLink MSP432 SDK is part of TI's SimpleLink platform allowing 100 percent code reuse between SimpleLink MCUs.

RTOS for MSP432™ Microcontrollers MSP432 MCUs offer compatibility with several TI and third party Real-Time Operating Systems (RTOS). Visit this link to learn about the key features of each to suit your design needs.

MSP EnergyTrace™ Technology EnergyTrace technology for MSP430 microcontrollers is an energy-based code analysis tool that measures and displays the energy profile of the application and helps to optimize it for ultra-low-power consumption.

Development Tools

Code Composer Studio™ Integrated Development Environment for MSP Microcontrollers Code Composer Studio is an integrated development environment (IDE) that supports all MSP microcontroller devices. Code Composer Studio comprises a suite of embedded software utilities used to develop and debug embedded applications. It includes an optimizing C/C++ compiler, source code editor, project build environment, debugger, profiler, and many other features. For more information, see the [Code Composer Studio™ IDE for SimpleLink™ MSP432™ MCUs User's Guide](#).

Arm® Keil® MDK – Free 32KB IDE The Arm Keil MDK is a complete debugger and C/C++ compiler toolchain for building and debugging embedded applications. Keil MDK supports the low-power + high performance MSP432 MCU family, and includes a fully integrated debugger for source and disassembly level debugging with support for complex code and data breakpoint. For more information, see the [Arm® Keil® MDK for SimpleLink™ MSP432™ MCUs User's Guide](#).

IAR Embedded Workbench® IDE IAR Embedded Workbench IDE is a complete debugger and C/C++ compiler toolchain for building and debugging embedded applications based on MSP430 and MSP432 microcontrollers. For more information, see the [IAR Embedded Workbench for Arm for SimpleLink™ MSP432™ MCUs User's Guide](#).

MSP432P4xx CMSIS Device Family Pack TI provides a CMSIS-compliant device family pack for MSP432P4xx devices. This pack adds MSP432P4xx device support to IAR EWARM 8.x, Keil MDK 5.x, and Atollic TrueSTUDIO® 7.x. In IAR EWARM this pack is optional as the IDE supports the devices natively.

Debuggers for MSP432™ MCUs MSP432 MCUs are designed to work with a variety of debuggers from Texas Instruments and third-party vendors.

MSP MCU Programmer and Debugger The MSP-FET is a powerful emulation development tool – often called a debug probe – which lets users quickly begin application development on MSP MCUs.

MSP-GANG Production Programmer The MSP Gang Programmer is an MSP430 and MSP432 device programmer that can program up to eight identical MSP430 or MSP432 flash or FRAM devices at the same time. The MSP Gang Programmer connects to a host PC using a standard RS-232 or USB connection and provides flexible programming options that let the user fully customize the process.

Pin Mux Tool The Pin Mux Utility is a software tool that provides a graphical user interface for configuring pin multiplexing settings, resolving conflicts, and specifying I/O cell characteristics for TI MPUs. Results are output as C header and code files that can be imported into SDKs or used to configure customer's custom software.

ULP (Ultra-Low Power) Advisor ULP Advisor™ software is a tool for guiding developers to write more efficient code to fully use the unique ultra-low-power features of MSP430 and MSP432 microcontrollers. Aimed at both experienced and new microcontroller developers, ULP Advisor checks your code against a thorough ULP checklist to squeeze every last nano amp out of your application.

8.4 Documentation Support

The following documents describe the MCUs. Copies of these documents are available on the [TI website](#).

Receiving Notification of Document Updates

To receive notification of documentation updates—including silicon errata—go to the product folder for your device on [ti.com](#) (for links to the product folders, see [Section 8.5](#)). In the upper right corner, click the "Alert me" button. This registers you to receive a weekly digest of product information that has changed (if any). For change details, check the revision history of any revised document.

Errata

MSP432P4111 Device Erratasheet Describes the known exceptions to the functional specifications.

MSP432P411Y Device Erratasheet Describes the known exceptions to the functional specifications.

MSP432P411V Device Erratasheet Describes the known exceptions to the functional specifications.

MSP432P4011 Device Erratasheet Describes the known exceptions to the functional specifications.

MSP432P401Y Device Erratasheet Describes the known exceptions to the functional specifications.

MSP432P401V Device Erratasheet Describes the known exceptions to the functional specifications.

User's Guides

MSP432P4xx SimpleLink™ Microcontrollers Technical Reference Manual Detailed description of all modules and peripherals available in this device family.

Code Composer Studio™ IDE for SimpleLink™ MSP432™ MCUs User's Guide This manual describes the use of the TI Code Composer Studio IDE (CCS) with the MSP432 low-power microcontrollers.

IAR Embedded Workbench for Arm for SimpleLink MSP432 MCUs User's Guide This manual describes the use of IAR Embedded Workbench for Arm (EWARM) with the MSP432 low-power microcontrollers.

Arm® Keil® MDK for SimpleLink™ MSP432™ Microcontrollers User's Guide This user's guide describes the use of the Arm Keil MDK with the MSP432 low-power microcontrollers.

GCC Arm® Embedded Toolchain for SimpleLink™ MSP432™ Microcontrollers User's Guide This manual describes the setup and basic operation of the MSP432 programming and debug using GCC Arm compiler and the GDB debugger.

MSP432™ SimpleLink™ Microcontrollers Bootloader (BSL) User's Guide The MSP432 BSL lets users communicate with embedded memory in the MSP432 microcontroller during the prototyping phase, final production, and in service. Both the programmable memory (flash memory) and the data memory (RAM) can be modified as required.

MSP432™ Capacitive Touch Software Library Programmer's Guide MSP432 microcontrollers are equipped with the peripherals needed to perform a capacitance measurement. The purpose of the capacitive touch software library is to create a single interface that can be integrated with the peripheral set found in MSP432 devices. This document explains the capacitive touch library configuration and use with MSP432 devices.

Application Reports

Platform Migrating to the SimpleLink™ MSP432™ Family This migration guide helps developers accurately assess the effort to migrate an existing application from the 16-bit MSP430 to the 32-bit SimpleLink MSP432 Arm platform if they so choose to. Ultimately, the migration guide is built to help derive a migration strategy with complete hardware and software coverage that properly migrates the existing application without introducing bugs due to platform differences while still taking advantage of the unique features and performance improvements in the 32-bit MSP432 devices.

Designing an Ultra-Low-Power (ULP) Application With SimpleLink™ MSP432™ Microcontrollers

With the growing system complexity in ultra-low-power microcontroller applications, minimizing the overall energy consumption is one of the most difficult problems to solve. Multiple aspects including silicon, other onboard hardware components, and application software must be considered. There are some obvious generic techniques that can be used to reduce energy consumption such as reducing operating voltage or frequency. Many of these generic techniques may not greatly reduce energy consumption independently, but taken as a whole, the results can be significant, as there are many interdependencies across these components.

Maximizing MSP432P4xx Voltage Regulator Efficiency This application report describes the relationship of the MSP432P4xx DC/DC and LDO, provides guidelines on choosing which is most efficient for your application, and gives board layout considerations for the DC/DC.

Leveraging Low-Frequency Power Modes on SimpleLink™ MSP432P4xx Microcontrollers Low power consumption is very important in all battery-powered embedded applications. But the operating frequency of these embedded applications can be diverse based the needs of the application. Some applications might require operating at higher frequencies, in the order of several megahertz, while some other applications might require operating at lower frequencies, in the order of a few tens or a few hundreds of kilohertz. There are several microcontrollers in the market that offer good active mode power consumption when the operating frequency is in the order of several megahertz. But it is a challenge to get the power consumption low when the operating frequency is in the order of kilohertz. The low-frequency power modes available on the MSP432P4xx microcontrollers offer very low power consumption when low frequency of operation is used by the target application.

Software IP Protection on MSP432P4xx Microcontrollers Differentiations in embedded software applications enable differentiated products. Companies invest significant money in building differentiated software application. Hence, protecting this investment (application or portions of the application) is extremely important. This application note describes how to protect software intellectual property (IP) running on the Texas Instruments MSP432P4xx family of microcontrollers.

8.5 Related Links

Table 8-2 lists quick access links. Categories include technical documents, support and community resources, tools and software, and quick access to order now.

Table 8-2. Related Links

PARTS	PRODUCT FOLDER	ORDER NOW	TECHNICAL DOCUMENTS	TOOLS & SOFTWARE	SUPPORT & COMMUNITY
MSP432P4111	Click here	Click here	Click here	Click here	Click here
MSP432P4011	Click here	Click here	Click here	Click here	Click here
MSP432P411Y	Click here	Click here	Click here	Click here	Click here
MSP432P401Y	Click here	Click here	Click here	Click here	Click here
MSP432P411V	Click here	Click here	Click here	Click here	Click here
MSP432P401V	Click here	Click here	Click here	Click here	Click here

8.6 Community Resources

The following links connect to TI community resources. Linked contents are provided "AS IS" by the respective contributors. They do not constitute TI specifications and do not necessarily reflect TI's views; see TI's [Terms of Use](#).

TI E2E™ Community

TI's *Engineer-to-Engineer (E2E) Community*. Created to foster collaboration among engineers. At e2e.ti.com, you can ask questions, share knowledge, explore ideas, and help solve problems with fellow engineers.

TI Embedded Processors Wiki

Texas Instruments Embedded Processors Wiki. Established to help developers get started with embedded processors from Texas Instruments and to foster innovation and growth of general knowledge about the hardware and software surrounding these devices.

8.7 Trademarks

MSP432, SimpleLink, LaunchPad, EnergyTrace, ULP Advisor, E2E are trademarks of Texas Instruments. CoreSight is a trademark of Arm Limited.

Arm, Cortex, Thumb, Keil are registered trademarks of Arm Limited.

Atollic TrueSTUDIO is a registered trademark of Atollic.

Bluetooth is a registered trademark of Bluetooth SIG.

ULPBench is a trademark of Embedded Microprocessor Benchmark Consortium.

Microsoft is a registered trademark of Microsoft Corporation.

Wi-Fi is a registered trademark of Wi-Fi Alliance.

8.8 Electrostatic Discharge Caution



This integrated circuit can be damaged by ESD. Texas Instruments recommends that all integrated circuits be handled with appropriate precautions. Failure to observe proper handling and installation procedures can cause damage.

ESD damage can range from subtle performance degradation to complete device failure. Precision integrated circuits may be more susceptible to damage because very small parametric changes could cause the device not to meet its published specifications.

8.9 Export Control Notice

Recipient agrees to not knowingly export or re-export, directly or indirectly, any product or technical data (as defined by the U.S., EU, and other Export Administration Regulations) including software, or any controlled product restricted by other applicable national regulations, received from disclosing party under nondisclosure obligations (if any), or any direct product of such technology, to any destination to which such export or re-export is restricted or prohibited by U.S. or other applicable laws, without obtaining prior authorization from U.S. Department of Commerce and other competent Government authorities to the extent required by those laws.

8.10 Glossary

[TI Glossary](#) This glossary lists and explains terms, acronyms, and definitions.

9 Mechanical, Packaging, and Orderable Information

The following pages include mechanical, packaging, and orderable information. This information is the most current data available for the designated devices. This data is subject to change without notice and revision of this document. For browser-based versions of this data sheet, see the left-hand navigation.

MECHANICAL DATA

MTQF013A – OCTOBER 1994 – REVISED DECEMBER 1996

PZ (S-PQFP-G100)

PLASTIC QUAD FLATPACK

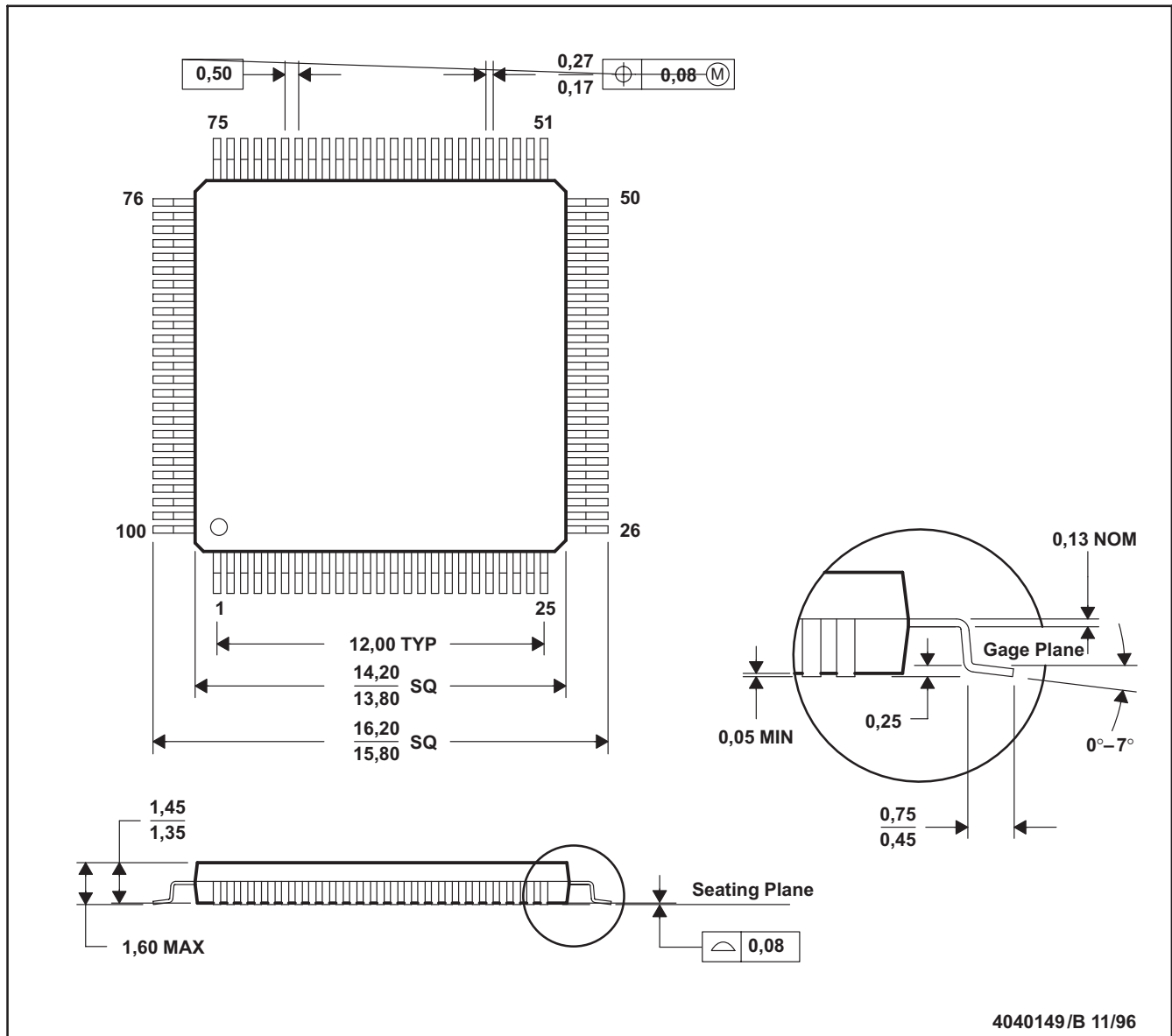

- NOTES: A. All linear dimensions are in millimeters.
B. This drawing is subject to change without notice.
C. Falls within JEDEC MS-026

LAND PATTERN DATA

PZ (S-PQFP-G100)

PLASTIC QUAD FLAT PACK

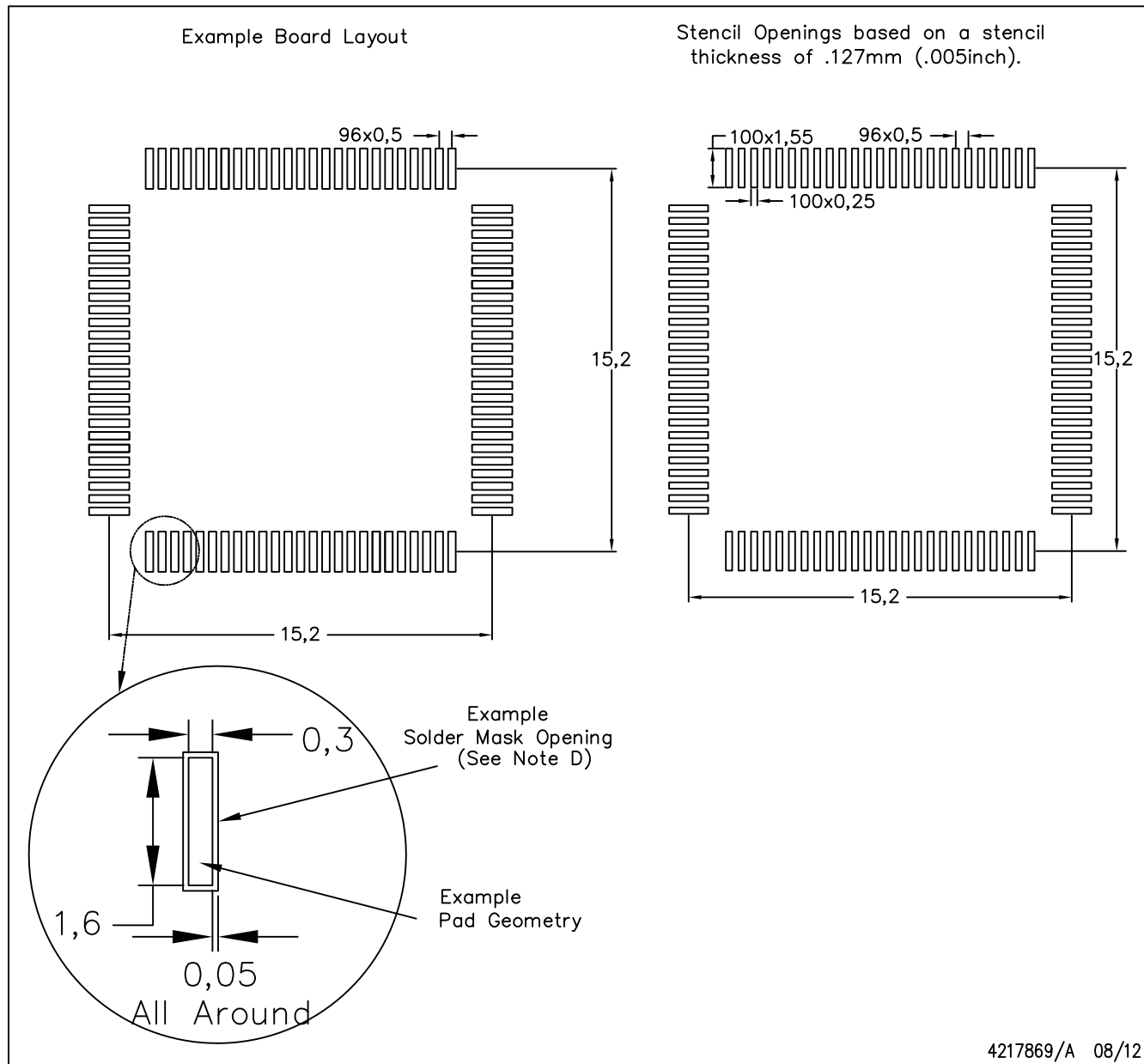

4217869/A 08/12

NOTES:

- A. All linear dimensions are in millimeters.
- B. This drawing is subject to change without notice.
- C. Laser cutting apertures with trapezoidal walls and also rounding corners will offer better paste release. Customers should contact their board assembly site for stencil design recommendations. Example stencil design based on a 50% volumetric metal load solder paste. Refer to IPC-7525 for other stencil recommendations.
- D. Customers should contact their board fabrication site for solder mask tolerances between and around signal pads.

RGC0064B

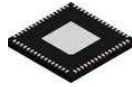

PACKAGE OUTLINE

VQFN - 1 mm max height

PLASTIC QUAD FLATPACK - NO LEAD

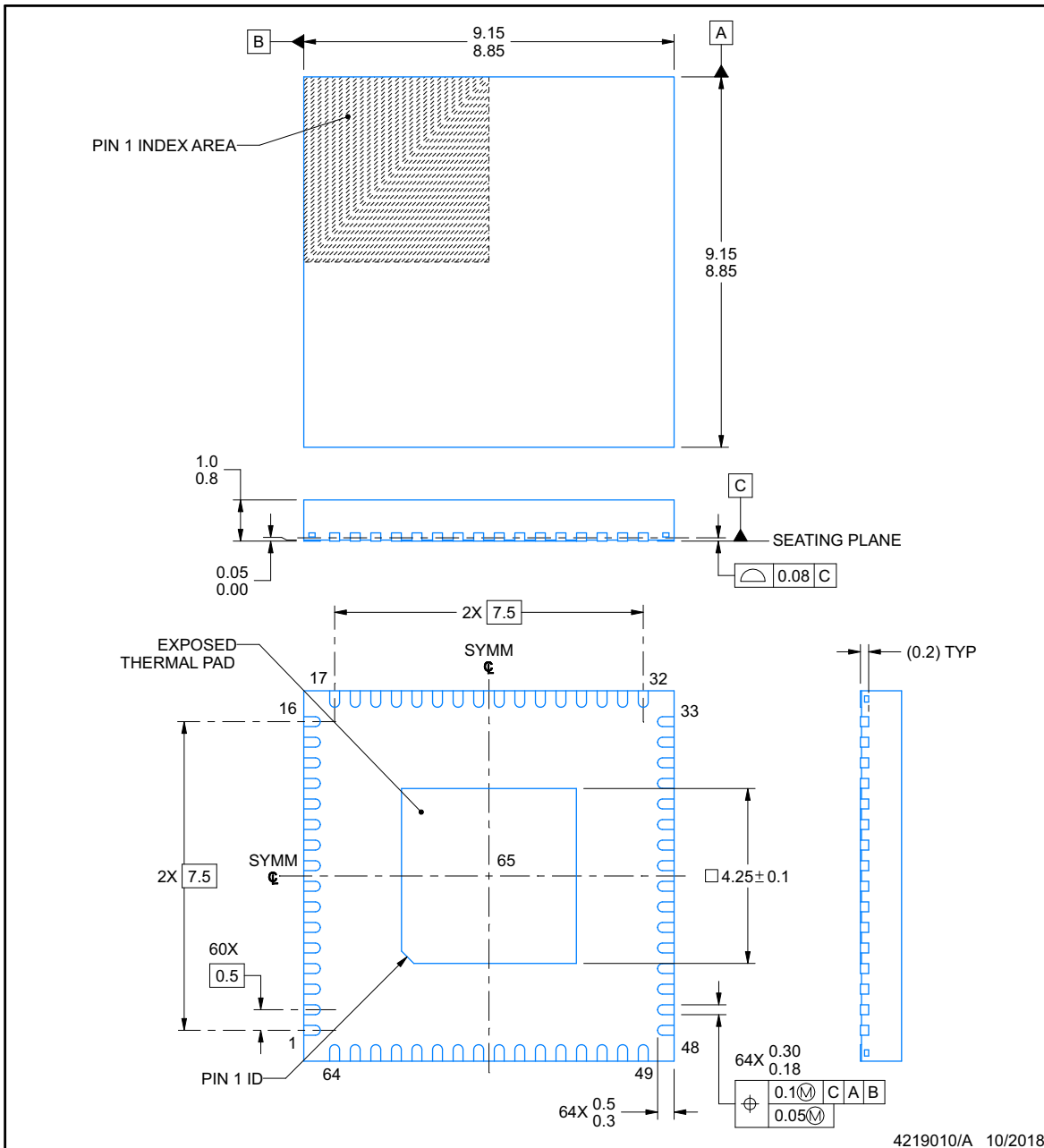

NOTES:

1. All linear dimensions are in millimeters. Any dimensions in parenthesis are for reference only. Dimensioning and tolerancing per ASME Y14.5M.
2. This drawing is subject to change without notice.
3. The package thermal pad must be soldered to the printed circuit board for thermal and mechanical performance.

EXAMPLE BOARD LAYOUT

RGC0064B

VQFN - 1 mm max height

PLASTIC QUAD FLATPACK - NO LEAD

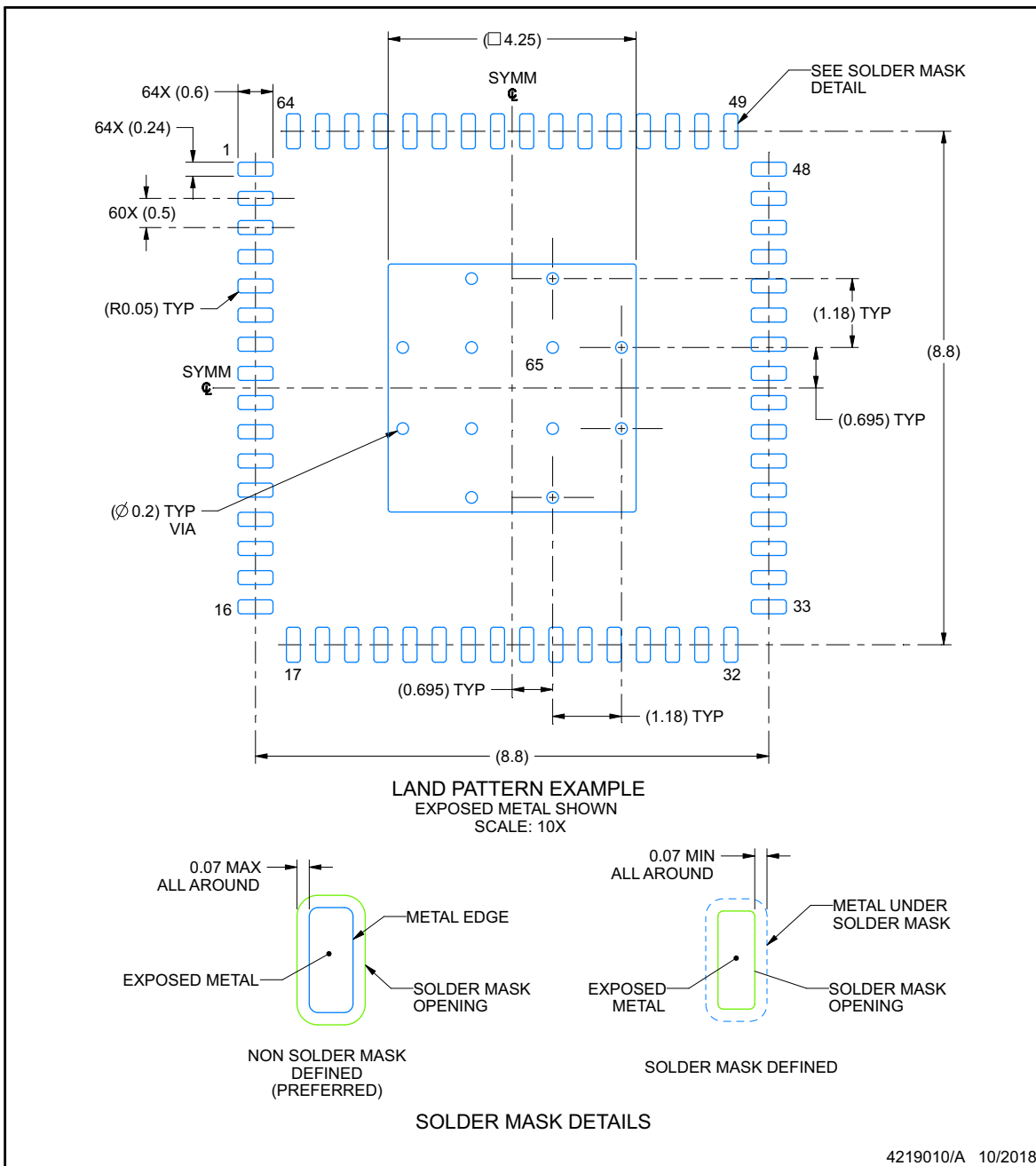

NOTES: (continued)

- This package is designed to be soldered to a thermal pad on the board. For more information, see Texas Instruments literature number SLUA271 (www.ti.com/lit/sluea271).
- Vias are optional depending on application, refer to device data sheet. If any vias are implemented, refer to their locations shown on this view. It is recommended that vias under paste be filled, plugged or tented.

EXAMPLE STENCIL DESIGN

RGC0064B

VQFN - 1 mm max height

PLASTIC QUAD FLATPACK - NO LEAD

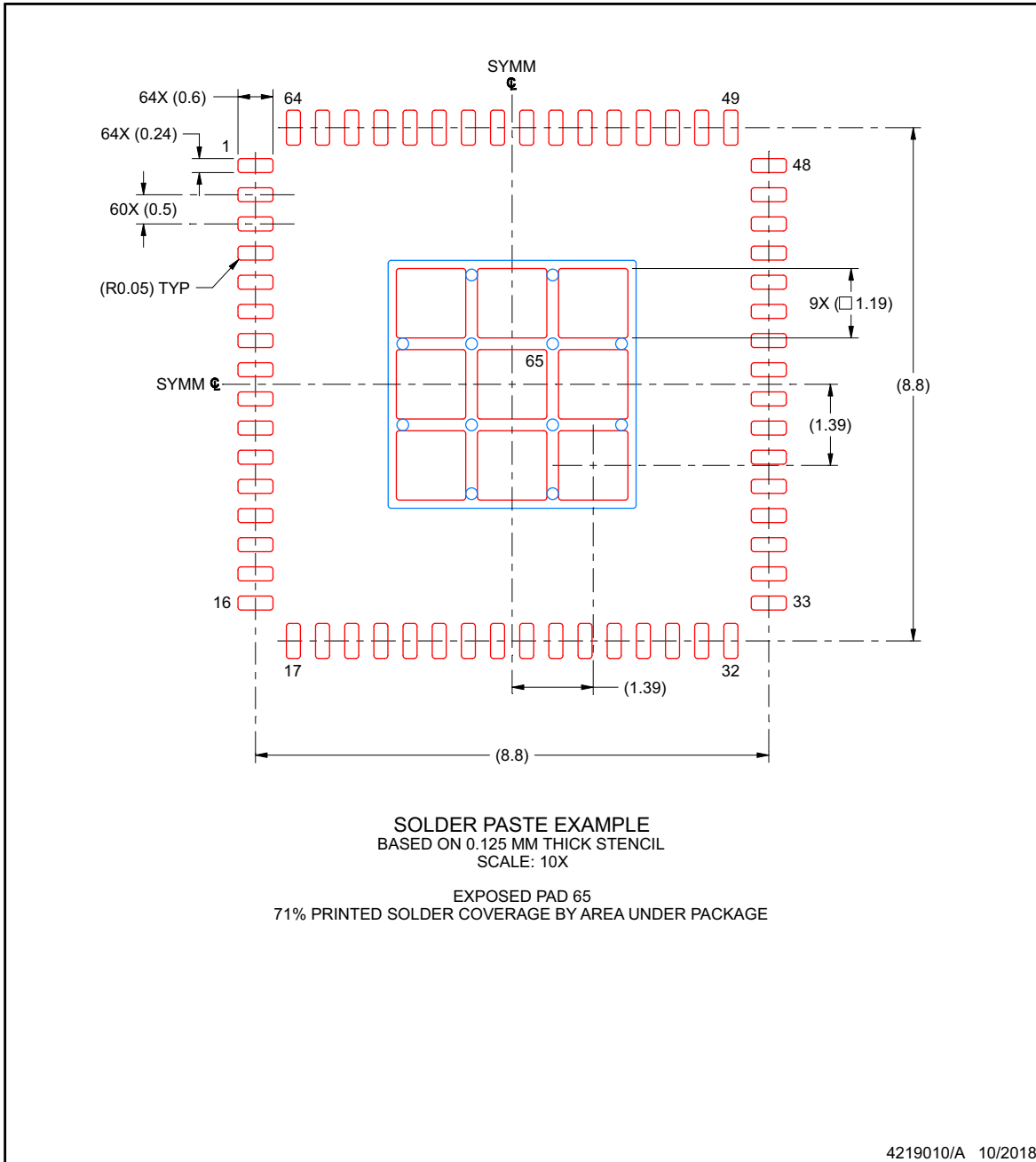

NOTES: (continued)

6. Laser cutting apertures with trapezoidal walls and rounded corners may offer better paste release. IPC-7525 may have alternate design recommendations.

PACKAGING INFORMATION

Orderable Device	Status (1)	Package Type	Package Drawing	Pins	Package Qty	Eco Plan (2)	Lead/Ball Finish (6)	MSL Peak Temp (3)	Op Temp (°C)	Device Marking (4/5)	Samples
MSP432P4011IRGCR	ACTIVE	VQFN	RGC	64	2000	Green (RoHS & no Sb/Br)	NIPDAUAG	Level-3-260C-168 HR	-40 to 85	P4011	Samples
MSP432P4011IRGCT	ACTIVE	VQFN	RGC	64	250	Green (RoHS & no Sb/Br)	NIPDAUAG	Level-3-260C-168 HR	-40 to 85	P4011	Samples
MSP432P401VIRGCR	ACTIVE	VQFN	RGC	64	2000	Green (RoHS & no Sb/Br)	NIPDAUAG	Level-3-260C-168 HR	-40 to 85	P401V	Samples
MSP432P401VIRGCT	ACTIVE	VQFN	RGC	64	250	Green (RoHS & no Sb/Br)	NIPDAUAG	Level-3-260C-168 HR	-40 to 85	P401V	Samples
MSP432P401YIRGCR	ACTIVE	VQFN	RGC	64	2000	Green (RoHS & no Sb/Br)	NIPDAUAG	Level-3-260C-168 HR	-40 to 85	P401Y	Samples
MSP432P401YIRGCT	ACTIVE	VQFN	RGC	64	250	Green (RoHS & no Sb/Br)	NIPDAUAG	Level-3-260C-168 HR	-40 to 85	P401Y	Samples
MSP432P4111IPZ	ACTIVE	LQFP	PZ	100	90	Green (RoHS & no Sb/Br)	NIPDAU	Level-3-260C-168 HR	-40 to 85	MSP432P4111	Samples
MSP432P4111IPZR	ACTIVE	LQFP	PZ	100	1000	Green (RoHS & no Sb/Br)	NIPDAU	Level-3-260C-168 HR	-40 to 85	MSP432P4111	Samples
MSP432P411VIPZ	ACTIVE	LQFP	PZ	100	90	Green (RoHS & no Sb/Br)	NIPDAU	Level-3-260C-168 HR	-40 to 85	MSP432P411V	Samples
MSP432P411VIPZR	ACTIVE	LQFP	PZ	100	1000	Green (RoHS & no Sb/Br)	NIPDAU	Level-3-260C-168 HR	-40 to 85	MSP432P411V	Samples
MSP432P411YIPZ	ACTIVE	LQFP	PZ	100	90	Green (RoHS & no Sb/Br)	NIPDAU	Level-3-260C-168 HR	-40 to 85	MSP432P411Y	Samples
MSP432P411YIPZR	ACTIVE	LQFP	PZ	100	1000	Green (RoHS & no Sb/Br)	NIPDAU	Level-3-260C-168 HR	-40 to 85	MSP432P411Y	Samples

(1) The marketing status values are defined as follows:

ACTIVE: Product device recommended for new designs.

LIFEBUY: TI has announced that the device will be discontinued, and a lifetime-buy period is in effect.

NRND: Not recommended for new designs. Device is in production to support existing customers, but TI does not recommend using this part in a new design.

PREVIEW: Device has been announced but is not in production. Samples may or may not be available.

OBSELETE: TI has discontinued the production of the device.

(2) **RoHS:** TI defines "RoHS" to mean semiconductor products that are compliant with the current EU RoHS requirements for all 10 RoHS substances, including the requirement that RoHS substance do not exceed 0.1% by weight in homogeneous materials. Where designed to be soldered at high temperatures, "RoHS" products are suitable for use in specified lead-free processes. TI may reference these types of products as "Pb-Free".

RoHS Exempt: TI defines "RoHS Exempt" to mean products that contain lead but are compliant with EU RoHS pursuant to a specific EU RoHS exemption.

Green: TI defines "Green" to mean the content of Chlorine (Cl) and Bromine (Br) based flame retardants meet JS709B low halogen requirements of ≤ 1000 ppm threshold. Antimony trioxide based flame retardants must also meet the ≤ 1000 ppm threshold requirement.

(3) MSL, Peak Temp. - The Moisture Sensitivity Level rating according to the JEDEC industry standard classifications, and peak solder temperature.

(4) There may be additional marking, which relates to the logo, the lot trace code information, or the environmental category on the device.

(5) Multiple Device Markings will be inside parentheses. Only one Device Marking contained in parentheses and separated by a "~" will appear on a device. If a line is indented then it is a continuation of the previous line and the two combined represent the entire Device Marking for that device.

(6) Lead/Ball Finish - Orderable Devices may have multiple material finish options. Finish options are separated by a vertical ruled line. Lead/Ball Finish values may wrap to two lines if the finish value exceeds the maximum column width.

Important Information and Disclaimer: The information provided on this page represents TI's knowledge and belief as of the date that it is provided. TI bases its knowledge and belief on information provided by third parties, and makes no representation or warranty as to the accuracy of such information. Efforts are underway to better integrate information from third parties. TI has taken and continues to take reasonable steps to provide representative and accurate information but may not have conducted destructive testing or chemical analysis on incoming materials and chemicals. TI and TI suppliers consider certain information to be proprietary, and thus CAS numbers and other limited information may not be available for release.

In no event shall TI's liability arising out of such information exceed the total purchase price of the TI part(s) at issue in this document sold by TI to Customer on an annual basis.

TAPE AND REEL INFORMATION

QUADRANT ASSIGNMENTS FOR PIN 1 ORIENTATION IN TAPE

*All dimensions are nominal

Device	Package Type	Package Drawing	Pins	SPQ	Reel Diameter (mm)	Reel Width W1 (mm)	A0 (mm)	B0 (mm)	K0 (mm)	P1 (mm)	W (mm)	Pin1 Quadrant
MSP432P4011IRGCR	VQFN	RGC	64	2000	330.0	16.4	9.3	9.3	1.1	12.0	16.0	Q2
MSP432P4011IRGCT	VQFN	RGC	64	250	180.0	16.4	9.3	9.3	1.1	12.0	16.0	Q2
MSP432P401VIRGCR	VQFN	RGC	64	2000	330.0	16.4	9.3	9.3	1.1	12.0	16.0	Q2
MSP432P401VIRGCT	VQFN	RGC	64	250	180.0	16.4	9.3	9.3	1.1	12.0	16.0	Q2
MSP432P401YIRGCR	VQFN	RGC	64	2000	330.0	16.4	9.3	9.3	1.1	12.0	16.0	Q2
MSP432P401YIRGCT	VQFN	RGC	64	250	180.0	16.4	9.3	9.3	1.1	12.0	16.0	Q2
MSP432P4111IPZR	LQFP	PZ	100	1000	330.0	32.4	16.9	16.9	2.0	24.0	32.0	Q2
MSP432P411VIPZR	LQFP	PZ	100	1000	330.0	32.4	16.9	16.9	2.0	24.0	32.0	Q2
MSP432P411YIPZR	LQFP	PZ	100	1000	330.0	32.4	16.9	16.9	2.0	24.0	32.0	Q2

TAPE AND REEL BOX DIMENSIONS

*All dimensions are nominal

Device	Package Type	Package Drawing	Pins	SPQ	Length (mm)	Width (mm)	Height (mm)
MSP432P4011IRGCR	VQFN	RGC	64	2000	367.0	367.0	38.0
MSP432P4011IRGCT	VQFN	RGC	64	250	210.0	185.0	35.0
MSP432P401VIRGCR	VQFN	RGC	64	2000	367.0	367.0	38.0
MSP432P401VIRGCT	VQFN	RGC	64	250	210.0	185.0	35.0
MSP432P401YIRGCR	VQFN	RGC	64	2000	367.0	367.0	38.0
MSP432P401YIRGCT	VQFN	RGC	64	250	210.0	185.0	35.0
MSP432P4111IPZR	LQFP	PZ	100	1000	367.0	367.0	55.0
MSP432P411VIPZR	LQFP	PZ	100	1000	367.0	367.0	55.0
MSP432P411YIPZR	LQFP	PZ	100	1000	367.0	367.0	55.0

IMPORTANT NOTICE AND DISCLAIMER

TI PROVIDES TECHNICAL AND RELIABILITY DATA (INCLUDING DATASHEETS), DESIGN RESOURCES (INCLUDING REFERENCE DESIGNS), APPLICATION OR OTHER DESIGN ADVICE, WEB TOOLS, SAFETY INFORMATION, AND OTHER RESOURCES "AS IS" AND WITH ALL FAULTS, AND DISCLAIMS ALL WARRANTIES, EXPRESS AND IMPLIED, INCLUDING WITHOUT LIMITATION ANY IMPLIED WARRANTIES OF MERCHANTABILITY, FITNESS FOR A PARTICULAR PURPOSE OR NON-INFRINGEMENT OF THIRD PARTY INTELLECTUAL PROPERTY RIGHTS.

These resources are intended for skilled developers designing with TI products. You are solely responsible for (1) selecting the appropriate TI products for your application, (2) designing, validating and testing your application, and (3) ensuring your application meets applicable standards, and any other safety, security, or other requirements. These resources are subject to change without notice. TI grants you permission to use these resources only for development of an application that uses the TI products described in the resource. Other reproduction and display of these resources is prohibited. No license is granted to any other TI intellectual property right or to any third party intellectual property right. TI disclaims responsibility for, and you will fully indemnify TI and its representatives against, any claims, damages, costs, losses, and liabilities arising out of your use of these resources.

TI's products are provided subject to TI's Terms of Sale (www.ti.com/legal/termsofsale.html) or other applicable terms available either on ti.com or provided in conjunction with such TI products. TI's provision of these resources does not expand or otherwise alter TI's applicable warranties or warranty disclaimers for TI products.

Mailing Address: Texas Instruments, Post Office Box 655303, Dallas, Texas 75265
Copyright © 2020, Texas Instruments Incorporated