



Liquid Crystal Display Television Service Manual

Chassis : MST6E16GS

Product Type : LCD26V88AM

LCD32V88AM

Ver 1.0

Hisense Electric Co. , Ltd.

April, 2009

A solid green horizontal bar is located at the bottom of the page.

Contents

<u>Contents.....</u>	<u>2</u>
<u>Service Manual.....</u>	<u>3</u>
1. Precautions and notices.....	3
1.1 WARNING.....	3
1.2 NOTES.....	5
2. Product Function Specifications.....	6
2.1 Product Function.....	6
2.2 Specifications	8
4. Chassis Layout and Overall Wiring Diagrams	10
5. Factory/Service OSD Menu and Adjustment.....	11
5.1 To enter the Factory OSD Menu	11
5.2 Factory OSD Menu	12
6. Software Upgrading.....	16
6.1 Get ready for upgrading.....	17
6.2 Upgrading with the ISP TOOL4.0.9.....	26
7. Troubleshooting.....	32
7.1 Troubleshooting for Remote Control.....	32
7.2 Troubleshooting for Function Key	33
7.3 TV won't Power On.....	34
7.4 Troubleshooting for Audio.....	35
7.5 Troubleshooting for TV/VGA/HDMI input.....	36
7.6 Troubleshooting for YPbPr input.....	37
7.7 Troubleshooting for Video/S-Video input.....	38
8. Explode View.....	39
9. Schematic circuit diagram.....	39

Service Manual

1. Precautions and notices

BEFORE SERVICING THE LCD TV, READ THE SAFETY PRECAUTIONS IN THIS MANUAL.

WHEN REPLACEMENT PARTS ARE REQUIRED, BE SURE TO USE REPLACEMENT PARTS SPECIFIED BY THE MANUFACTURER.

Proper service and repair is important to the safe, reliable operation of all Hisense Electric Co., Ltd Equipment. The service procedures recommended by Hisense and described in this Service Guide are effective methods of performing service operations. Some of these service operations require the use of tools specially designed for the purpose. The special tools should be used when and as recommended.

It is important to note that this manual contains various CAUTIONS and NOTICES which should be carefully read in order to minimize the risk of personal injury to service personnel. The possibility exists that improper service methods may damage the equipment. It is also important to understand that these CAUTIONS and NOTICES ARE NOT EXHAUSTIVE. Hisense could not possibly know, evaluate and advise the service trade of all conceivable ways in which service might be done or of the possible hazardous consequences of each way. Consequently, Hisense has not undertaken any such broad evaluation. Accordingly, a serviceman that uses a service procedure or tools, which are not recommended by Hisense, must first satisfy himself thoroughly that neither his safety nor the safe of the equipment will be jeopardized by the service method selected.

Hereafter throughout this manual, Hisense Electric Co., Ltd will be referred to as Hisense.

1.1 WARNING

1.1.1

Critical components having special safety characteristics are identified with a ▲ by the Ref. No. in the parts list. Use of substitute replacement parts, which do not have the same specified safety characteristics, may create shock, fire, or other hazards. Under no circumstances should the original design be modified or altered without written permission from Hisense. Hisense assumes no liability, express or implied, arising from the use of substitute replacement parts.

DANGEROUS CAUTION

TO ENSURE THE CONTINUED RELIABILITY OF THIS PRODUCT, USE ONLY ORIGINAL MANUFACTURER'S REPLACEMENT PARTS, WHICH ARE LISTED WITH THEIR PART NUMBERS IN THE PARTS LIST SECTION OF THIS SERVICE GUIDE.

liability.

1.1.2.

All ICs and many other semiconductors are susceptible to electrostatic discharges (ESD). Careless handling during repair can reduce life drastically. When repairing, make sure that you are connected with the same potential as the mass of the set by a wristband with resistance. Keep components and tools also at this same potential.

1. Never replace modules or other components while the unit is switched on.

2. When making settings, use plastic rather than metal tools. This will prevent any short circuits and the danger of a circuit becoming unstable.

1.1.3

To prevent electrical shock, do not use this polarized ac plug with an extension cord, receptacle, or the outlet unless the blades can be fully inserted to prevent blade exposure.

To prevent electrical shock, match wide blade or plug to wide slot, fully insert.

1.1.4

When replacement parts are required, be sure to use replacement parts specified by the manufacturer or have the same characteristics as the original part. Unauthorized substitutions may result in fire, electric shock, or other hazards.

1.1.5

Safety regulations require that after a repair the set must be returned in its original condition. In particular attention should be paid to the following points.

- Note: The wire trees should be routed correctly and fixed with the mounted cable clamps.

- The insulation of the mains lead should be checked for external damage.

1.1.6

- (1) Do not touch Signal and Power Connector while this product operates. Do not touch EMI ground part and Heat Sink of Film Filter.

- (2) Do not supply a voltage higher than that specified to this product. This may damage the product and may cause a fire.

- (3) Do not use this product in locations where the humidity is extremely high, where it may be splashed with water, or where flammable materials surround it. Do not install or use the product in a location that does not satisfy the specified environmental conditions. This may damage the product and may cause a fire.

- (4) If a foreign substance (such as water, metal, or liquid) gets inside the panel module, immediately turn off the power. Continuing to use the product may cause fire or electric shock.

- (5) If the product emits smoke, and abnormal smell, or makes an abnormal sound,

immediately turn off the power. Continuing to use the product, it may cause fire or electric shock.

(6) Do not disconnect or connect the connector while power to the product is on. It takes some time for the voltage to drop to a sufficiently low level after the power has been turned off. Confirm that the voltage has dropped to a safe level before disconnecting or connecting the connector.

(7) Do not pull out or insert the power cable from/to an outlet with wet hands. It may cause electric shock.

(8) Do not damage or modify the power cable. It may cause fire or electric shock.

(9) If the power cable is damaged, or if the connector is loose, do not use the product: otherwise, this can lead to fire or electric shock.

(10) If the power connector or the connector of the power cable becomes dirty or dusty, wipe it with a dry cloth. Otherwise, this can lead to fire.

(11) Use only with the cart, stand, tripod, bracket, or table specified by the manufacturer, or sold with the apparatus. When a cart is used, use caution when moving the cart/apparatus combination to avoid injury from tip-over.

1.2 NOTES

Notes on Safe Handling of the LCD panel and during service

The work procedures shown with the Note indication are important for ensuring the safety of the product and the servicing work. Be sure to follow these instructions.

- Before starting the work, secure a sufficient working space.
- At all times other than when adjusting and checking the product, be sure to turn OFF the POWER Button and disconnect the power cable from the power source of the TV during servicing.
- To prevent electric shock and breakage of PC board, start the servicing work at least 30 seconds after the main power has been turned off. Especially when installing and removing the power board, start servicing at least 2 minutes after the main power has been turned off.
- While the main power is on, do not touch any parts or circuits other than the ones specified. If any connection other than the one specified is made between the measuring equipment and the high voltage power supply block, it can result in electric shock or activation of the leakage-detection circuit breaker.
- When installing the LCD module in, and removing it from the packing carton, be sure to have at least two persons perform the work.
- When the surface of the panel comes into contact with the cushioning materials, be sure to confirm that there is no foreign matter on top of the cushioning materials before the surface of the panel comes into contact with the cushioning materials. Failure to observe this precaution may result in, the surface of the panel being scratched by foreign matter.

- When handling the circuit board, be sure to remove static electricity from your body before handling the circuit board.
- Be sure to handle the circuit board by holding the large parts as the heat sink or transformer. Failure to observe this precaution may result in the occurrence of an abnormality in the soldered areas.
- Do not stack the circuit boards. Failure to observe this precaution may result in problems resulting from scratches on the parts, the deformation of parts, and short-circuits due to residual electric charge.
- Routing of the wires and fixing them in position must be done in accordance with the original routing and fixing configuration when servicing is completed. All the wires are routed far away from the areas that become hot (such as the heat sink). These wires are fixed in position with the wire clamps so that the wires do not move, thereby ensuring that they are not damaged and their materials do not deteriorate over long periods of time. Therefore, route the cables and fix the cables to the original position and states using the wire clamps.
- Perform a safety check when servicing is completed. Verify that the peripherals of the serviced points have not undergone any deterioration during servicing. Also verify that the screws, parts and cables removed for servicing purposes have all been returned to their proper locations in accordance with the original setup.



The lightning flash with arrowhead symbol, within an equilateral triangle is intended to alert the user to the presence of uninsulated dangerous voltage within the products enclosure that may be of sufficient magnitude to constitute a risk of electric shock.



The exclamation point within an equilateral triangle is intended to alert the user to the presence of important operating and maintenance (servicing) instructions in the literature accompanying the set.

2. Product Function Specifications

2.1 Product Function

TV Front

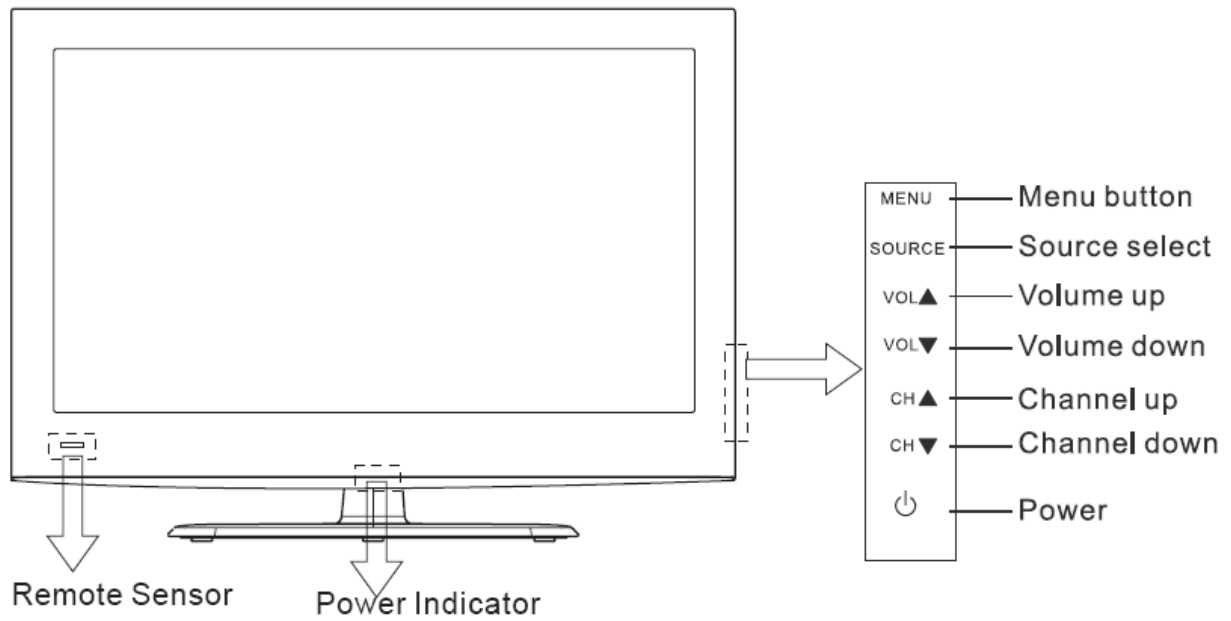

TV Rear

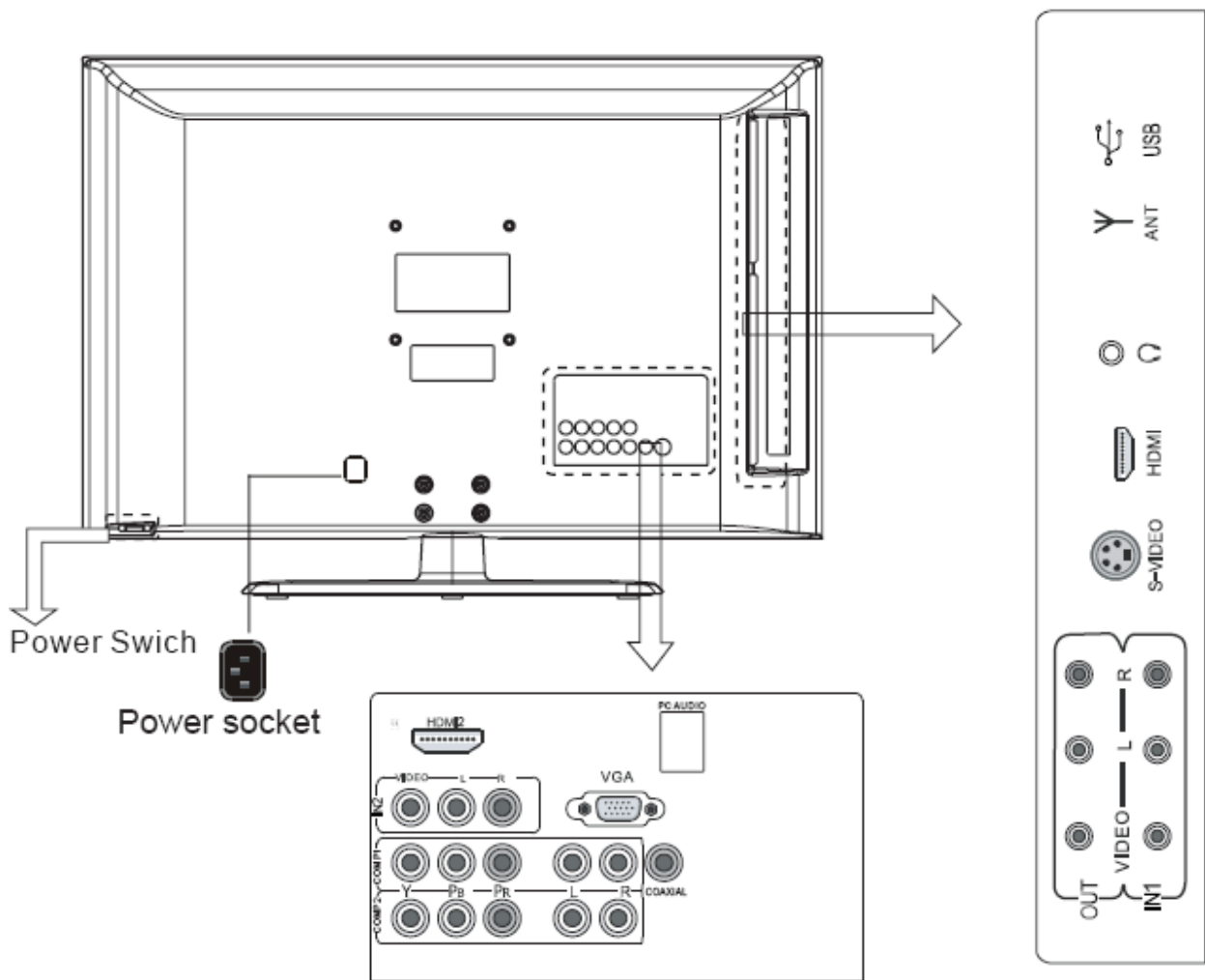

2.2 Specifications

3. LCD Panel Spec

3.1 LCD26V88AM

Model : V260B2-L03\JK\ROH SN : 1056993

3.1.1 General Description

1.1 OVERVIEW

V260B2- L03 is a TFT Liquid Crystal Display module with 4U-CCFL Backlight unit and 1ch-LVDS interface. The display diagonal is 26". This module supports 1366 x 768 WXGA format and can display 16.2M colors (6-bit+FRC colors).

1.2 FEATURES

- Optimized Brightness 450nits
- Contrast Ratio (800:1)
- Fast Response Time (5ms)
- Color Saturation NTSC 72%
- WXGA (1366 x 768 pixels) Resolution
- DE (Data Enable) Only Mode
- LVDS (Low Voltage Differential Signaling) Interface
- Viewing Angle: 160(H)/150(V) (CR>10) TN Technology
- Color Reproduction (Nature Color)

3.1.2 General Features

Item	Specification	Unit
Active Area	575.769 (H) x 323.712 (V) (26" Diagonal)	mm
Bezel Opening Area	580.8 (H) x 328.8 (V)	mm
Driver Element	a-si TFT Active Matrix	—
Pixel Number	1366 x R.G.B. x 768	pixel
Pixel Pitch (Sub Pixel)	0.1405 (H) x 0.4215 (V)	mm
Pixel Arrangement	RGB Vertical Stripe	—
Display Colors	16.2M	color
Display Operation Mode	Transmissive Mode / Normally White	—
Surface Treatment	Anti-Glare Coating (Haze 25%) Hard Coating (3H)	—

3.2、LCD32V88AM

Model : T315XW02VS\JK\ROH SN : 1057962

3.2.1 General Description

LCD TV Service Manual

This specification applies to the 31.51 inch Color TFT-LCD Module T315XW02 VS. This LCD module has a TFT active matrix type liquid crystal panel 1366x768 pixels, and diagonal size of 31.51 inch. This module supports 1366x768 XGA-WIDE mode (Non-interlace).

Each pixel is divided into Red, Green and Blue sub-pixels or dots which are arranged in vertical stripes. Gray scale or the brightness of the sub-pixel color is determined with a 8-bit gray scale signal for each dot.

The T315XW02 VS has been designed to apply the 8-bit 1 channel LVDS interface method. It is intended to support displays where high brightness, wide viewing angle, high color saturation, and high color depth are very important.

The T315XW02 VS model is RoHS verified which can be distinguished on panel label.

3.2.2 General Features

Items	Specification	Unit	Note
Active Screen Size	31.51 inches		
Display Area	697.685 (H) x 392.256(V)	mm	
Outline Dimension	760.0(H) x 450.0(V) x 45(D)	mm	With Inverter
Driver Element	a-Si TFT active matrix		
Display Colors	16.7M	Colors	
Number of Pixels	1366 x 768	Pixel	
Pixel Pitch	0.51075	mm	
Pixel Arrangement	RGB vertical stripe		
Display Mode	Normally Black		
Surface Treatment	Anti-Glare, 3H		Haze =11 %

4. Chassis Layout and Overall Wiring Diagrams

Chassis Layout

LCD26V88AM

No	Description	Part No.	Type/Model	PCB/ Model

Hisense Confidential

LCD TV Service Manual

(1)	Main Board	121044	RSAG2.908.1525-1\ROH	RSAG7.820.1702\VER.D\ROH
(2)	Power Board	118984	RSAG2.908.1498\ROH	RSAG7.820.1646\VER.C\ROH
(3)	Keypad PCA	121048	RSAG2.908.1573-4\ROH	RSAG7.820.1755\VER.A\ROH
(4)	IR Board	120680	RSAG2.908.1551-2\ROH	RSAG7.820.1733\VER.B\ROH
(5)	Led Board	119914	RSAG2.908.1552\ROH	RSAG7.820.1732\VER.A\ROH

LCD32V88AM

No	Description	Part No.	Type/Model	PCB/ Model
(1)	Main board	121044	RSAG2.908.1525-1\ROH	RSAG7.820.1702\VER.D\ROH
(2)	Power board	117562	RSAG2.908.1285-1\ROH	RSAG7.820.1377\VER.B\ROH
(3)	Keypad	121048	RSAG2.908.1573-4\ROH	RSAG7.820.1755\VER.A\ROH
(4)	IR board	121225	RSAG2.908.1566-3\ROH	RSAG7.820.1725\VER.C\ROH
(5)	Led Board	120110	RSAG2.908.1534-2\ROH	RSAG7.820.1699\VER.B\ROH

5. Factory/Service OSD Menu and Adjustment

5.1 To enter the Factory OSD Menu

a. With factory RC (remote control)

1. Press “M” button and enter factory mode.
2. Press “Menu” button and enter factory OSD menu.
3. Press “CH+”/“CH-” button select the function menu, press “VOL+”/“VOL-” enter the selected function menu. Press “VOL+”/“VOL-” button adjust values in the menu.
4. Press “M” button exit factory mode in the factory OSD menu.

LCD TV Service Manual

When TV outgoing factory, user can not enter factory OSD menu with Factory Remote

b. With user's RC

1. Power TV On
2. Press Menu button and call up User OSD Menu
3. Select Sound-> Balance
4. When Balance value is "0", Enter 0->5->3 ->2 in sequence.
Note: If necessary, re-do number keys.
5. Factory OSD appears.
6. Press the standby button then AC turn off and restart the TV, which can exit factory OSD menu.

5.2 Factory OSD Menu

The Factory OSD Menu comprises Factory Menu and Design Menu .

5.2.1、 Factory Menu

Factory Menu
White Balance
ADC Adjust
LOGO
OSD Language
Country
Options
Factory Init
Test Pattern
Version:

White Balance
Col Temp **standard**
R DRV **126**
G DRV **128**
B DRV **128**
R CUT **32**
G CUT **32**
B CUT **32**

ADC Adjust

Only in component and VGA

SOURCE ,The 摺 DC
Adjust ◆ Can be chosen.

LOGO

NULL
HISENSE
WELCOME
CUSTOMER

Option

SOURCE TV
TOFAC M
AGC TOP 5
AGC CURVE 80
ATS 1
Star TUP Menu 1
MACHINE TYPE 0
HIDEF 1

Factory Init

QingDao
HuangDao
Hungary
France
Australia
CLEAR PROTECTLY
CLEAR UNPROTECTLY

Test Pattern

Test pattern NULL

Version

Version:
Panel Type:
FLASH :

5.2.2、 Design Menu

Design Menu

Picture Mode
Sound Mode
Picture Curve
Audio Curve
SSC Setting
Saving MODE

LCD TV Service Manual

Picture Mode

Mode	Standard
Brightness	50
Contrast	50
Colour	50

Sound Mode

Mode	User
120Hz	10
500Hz	10
1.5KHz	10
5KHz	10
10KHz	10

Picture Curve

Mode	Brightness
Curve 0	97
Curve 25	105
Curve 50	120
Curve 75	130
Curve 100	141

Audio Curve

Mode	Volume
Curve 0	0
Curve 25	18
Curve 50	22
Curve 75	28
Curve 100	36

SSC Setting

DDR SSC	2
DDR MCM	60
LVDS SSC	2
LVDS PCM	60

Saving MODE

255

Note :

The above "Factory/Service OSD Menu" are reference only, please refer to the actual units to

Hisense Confidential

determine the appearances.

6. Software Upgrading

The software is upgraded by a burning tool- ISP_TOOL4.0.9, which can burn the program file“* . bin” to the main board of the unit

LCD TV Service Manual

6.1 Get ready for upgrading

6.1.1 Install the ISP_TOOL4.0.9-----only for the first time update.

1、 Port Setting :



Choose “system” option from the “control panel”

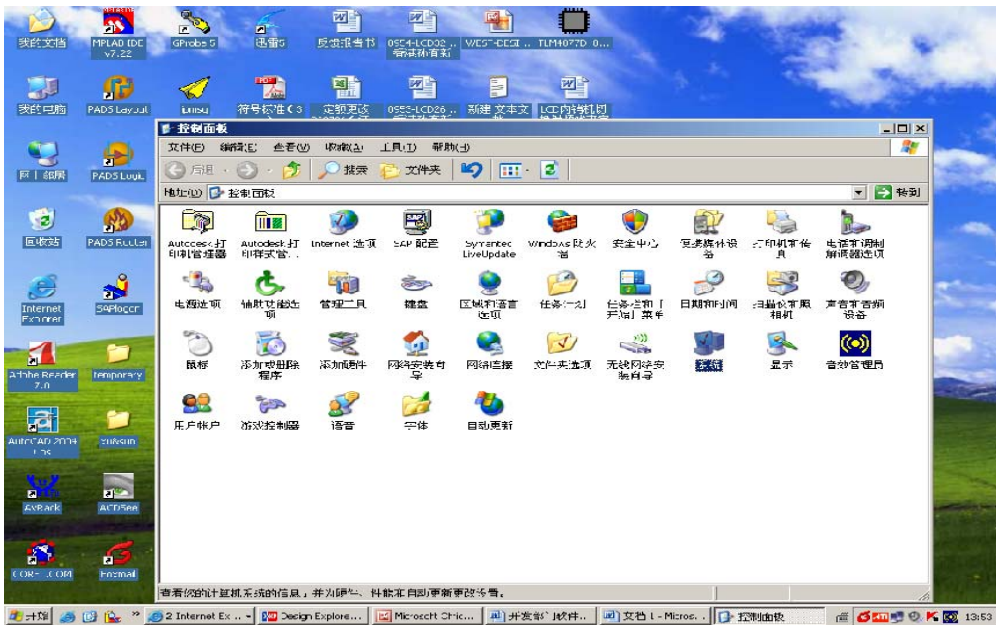

Click the “system” icon as the following

LCD TV Service Manual



Choose the “hardware” option from the dialog window



Click “device management” icon as the following

Hisense Confidential

LCD TV Service Manual

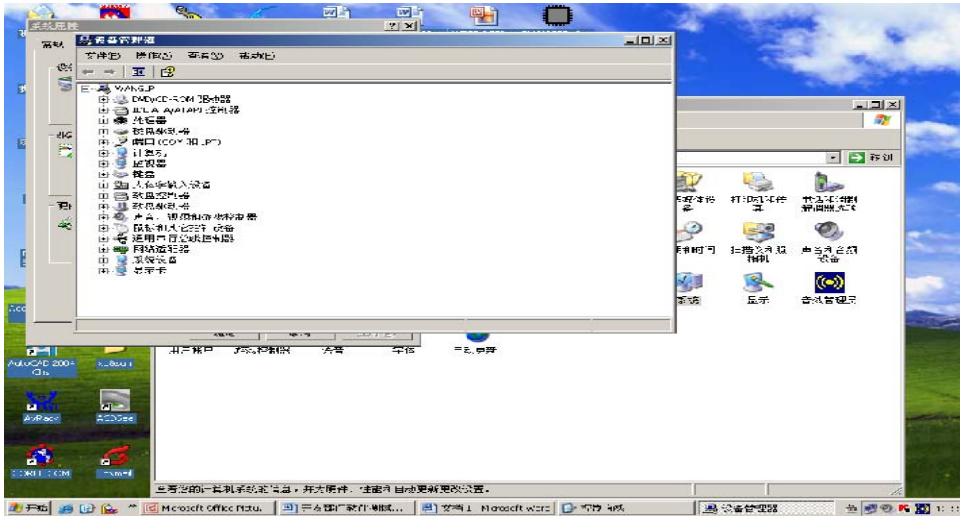

Choose the port (COM and LPT1)



Choose the ECP print port (LPT1)

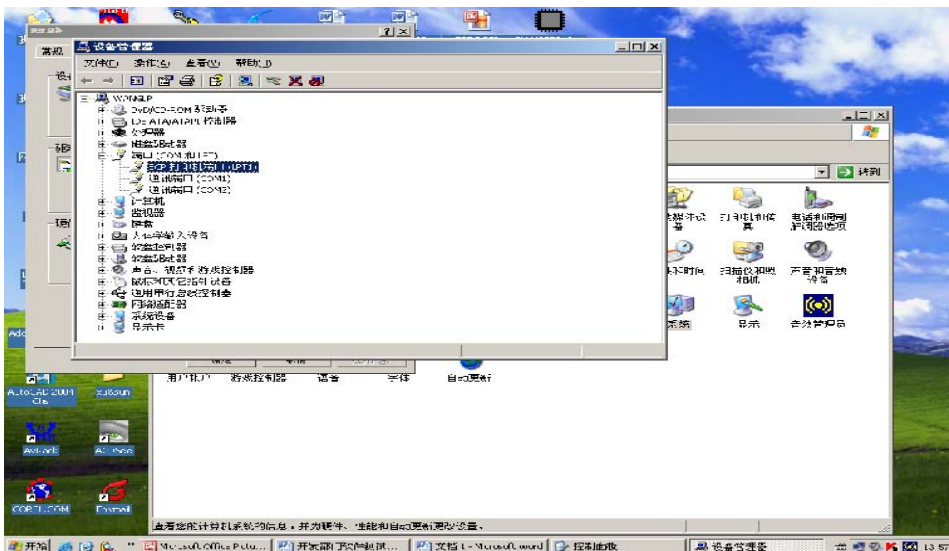

Hisense Confidential

LCD TV Service Manual

Click the port of print (LPT1) as the following

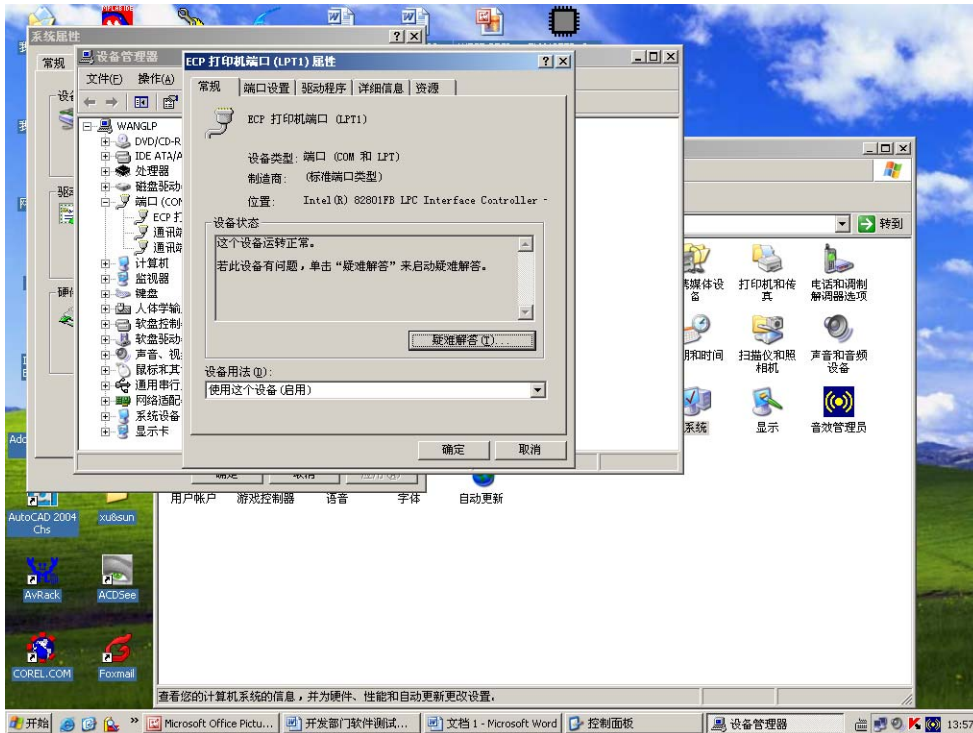

Choose "port setting" option as the following

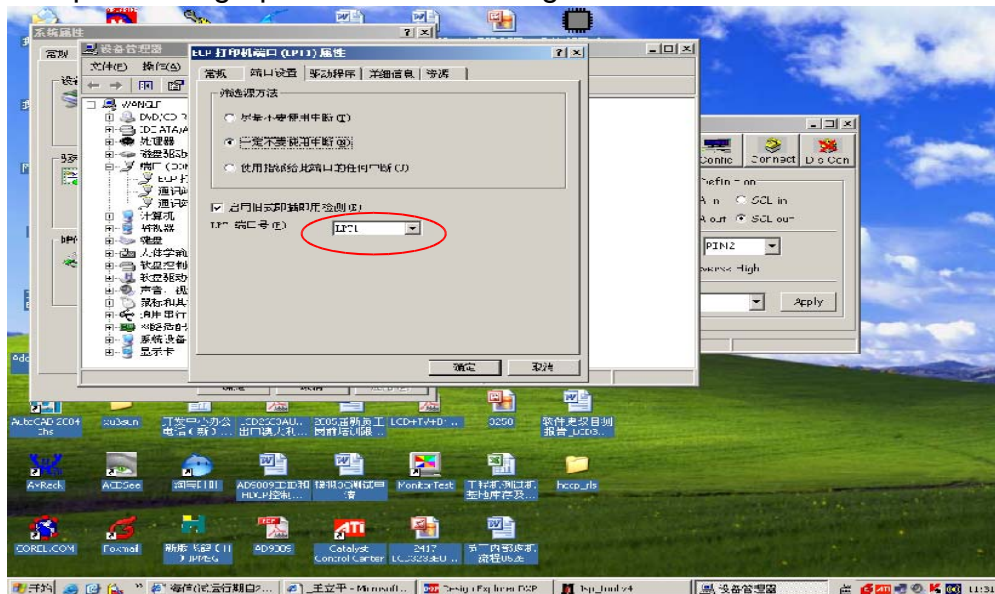

LCD TV Service Manual

- 2、 Find the folder where the ISP_TOOL4.0.9 lies in.
There are three folders/files in this folder together.
DLPORTIO.dll and FTD2XX.DLL must be in the same folder

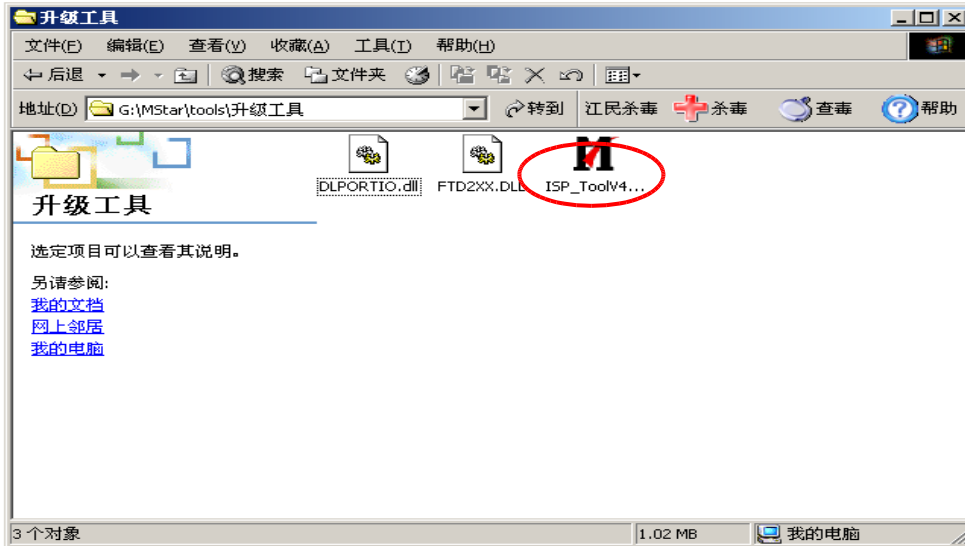

Double click the ISP_TOOL4.0.9 icon, and then a dialog window will show as below.

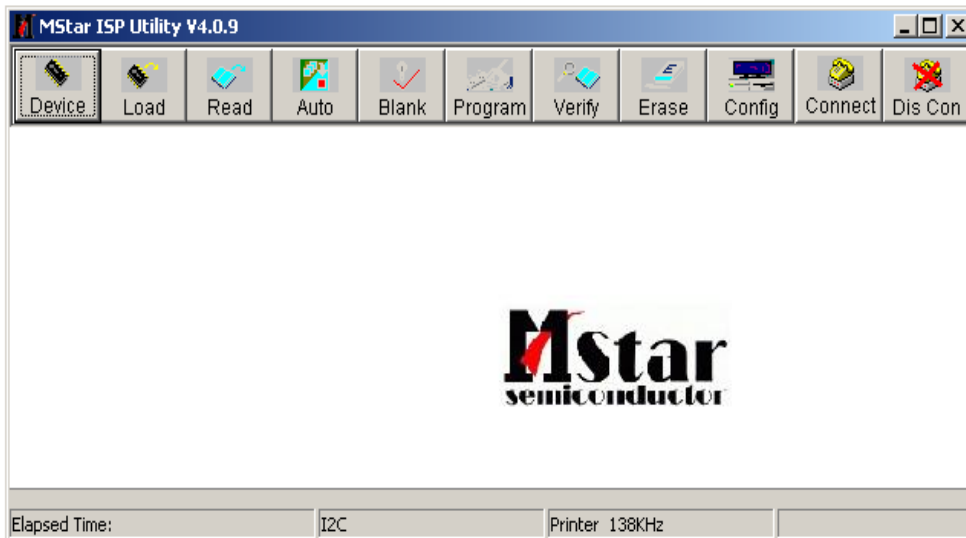

LCD TV Service Manual

Click the **Config** button. And then a dialog window will show as below.

Port Type setting is LPT1

Base Addr setting is 0x378

Draw on the front of “pin 1 switch UART/I2c”

Speed setting is 99

As following

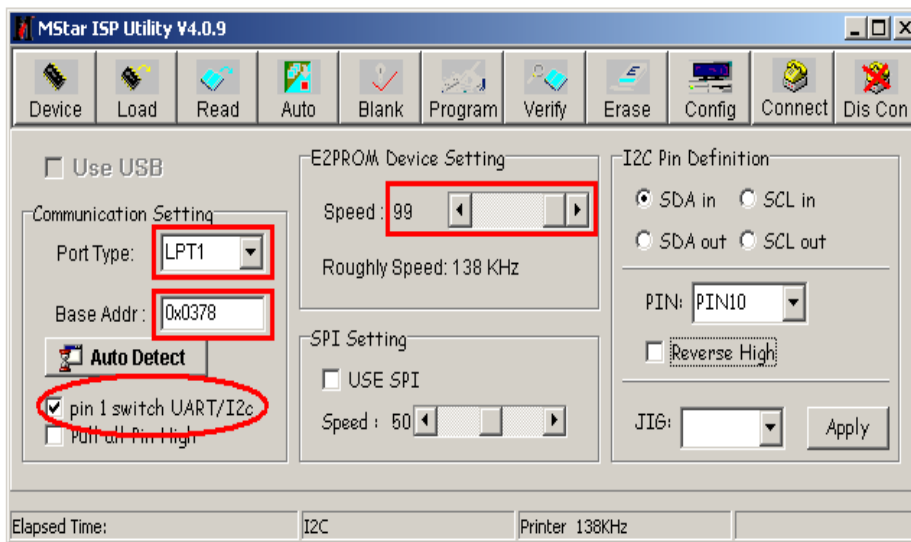

Choose “SDA in” and setting “PIN” is “PIN10”.

Notes:

Do not draw on the front of “Reverse High”.

As following

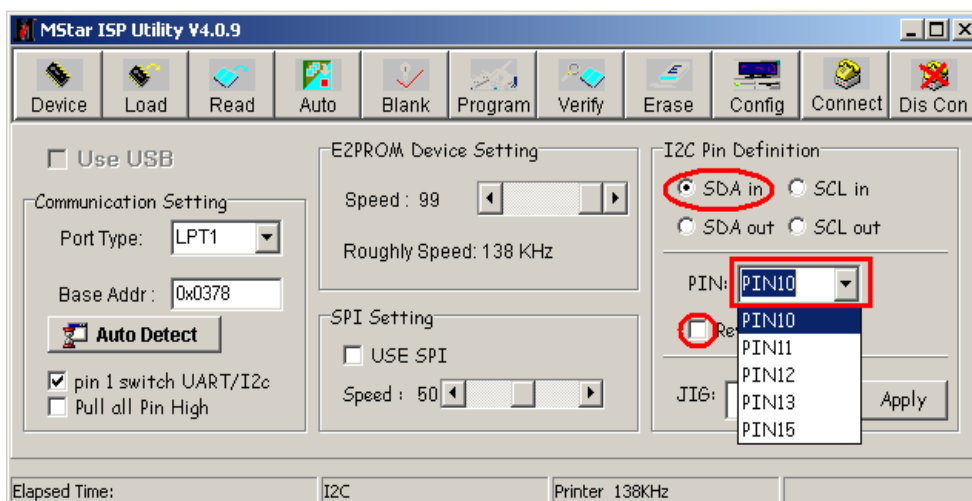

LCD TV Service Manual

Choose “SCL in” and setting “PIN” is “PIN11”。

Notes:

Do not draw on the front of “Reverse High”。

As following

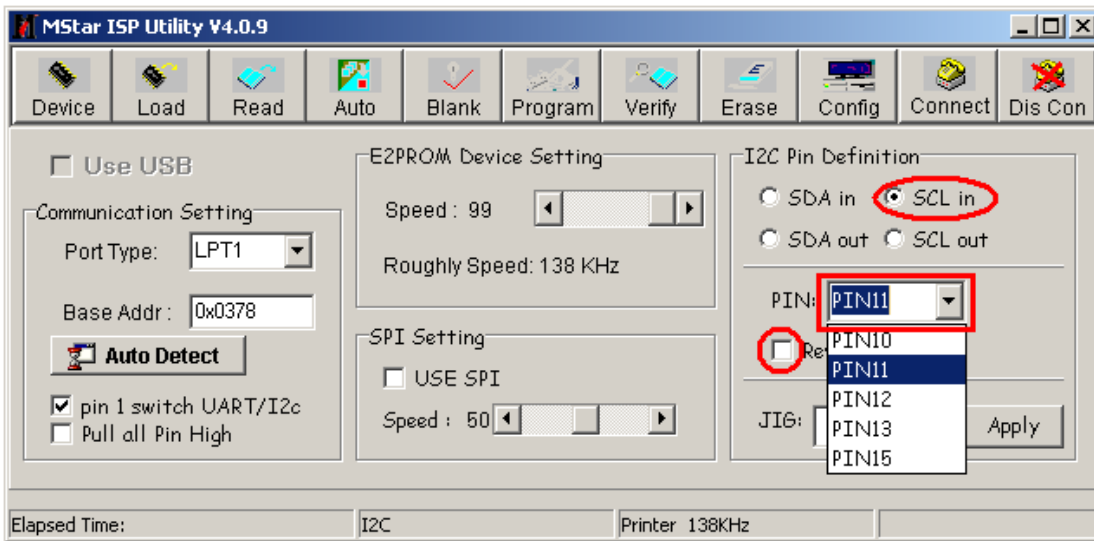

Choose “SDA out” and setting “PIN” is “PIN4”

Notes:

Draw on the front of “Reverse High”。

As following。

LCD TV Service Manual

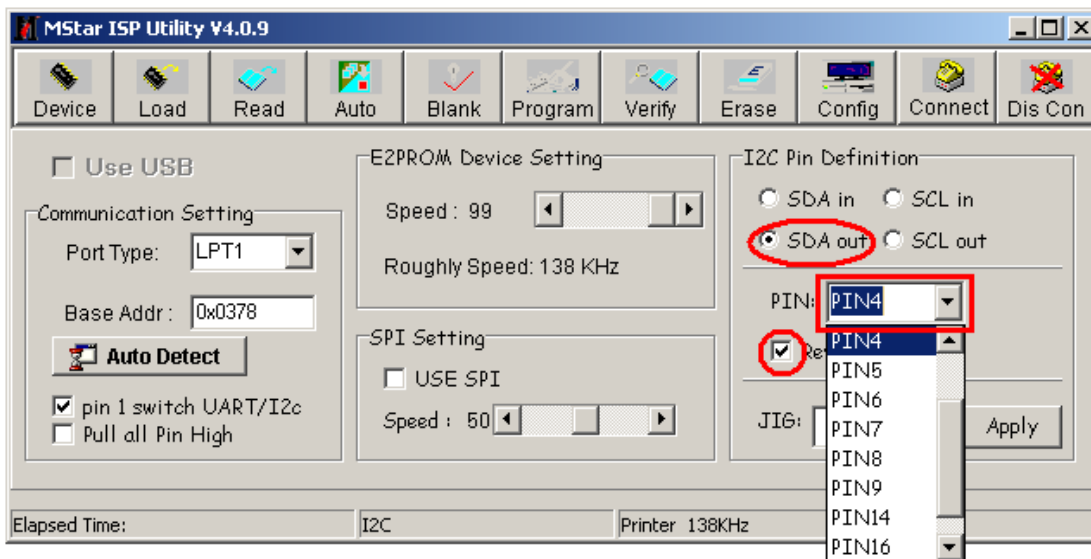

Choose “SCL out” and setting “PIN” is “PIN2”

Notes:

Draw on the front of “Reverse High”

As following

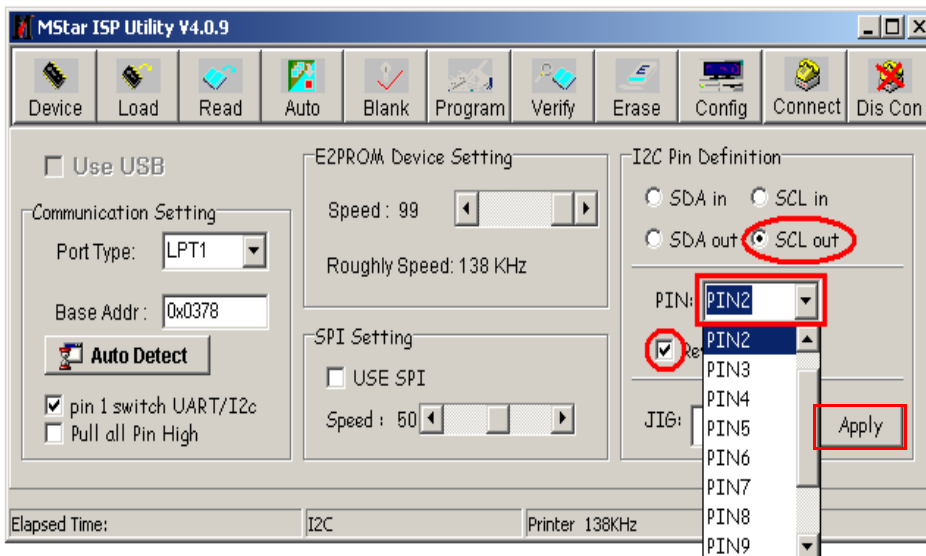

After having finished all above, clicking the “Apply ”button to complete the configuration.

6.1.2 Hardware connecting

You can update the software through a special tool (as following)

LCD TV Service Manual

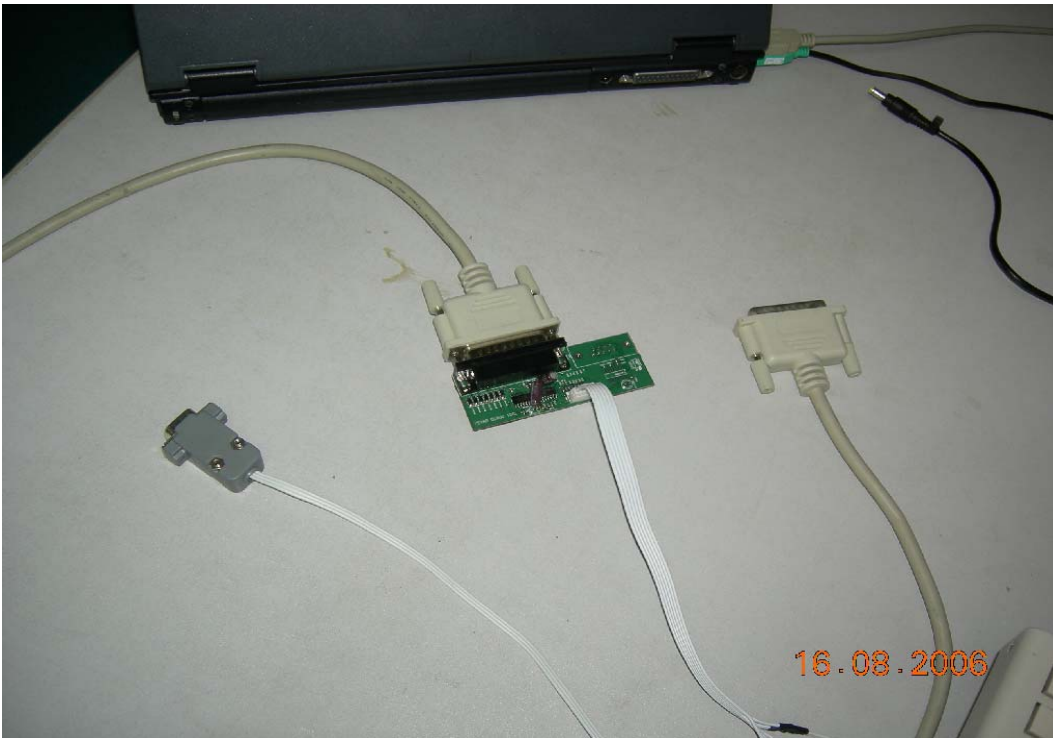

Connect the Debug board to the TV use VGA interface, the other parallel port to the computer, just as the following.



Hisense Confidential

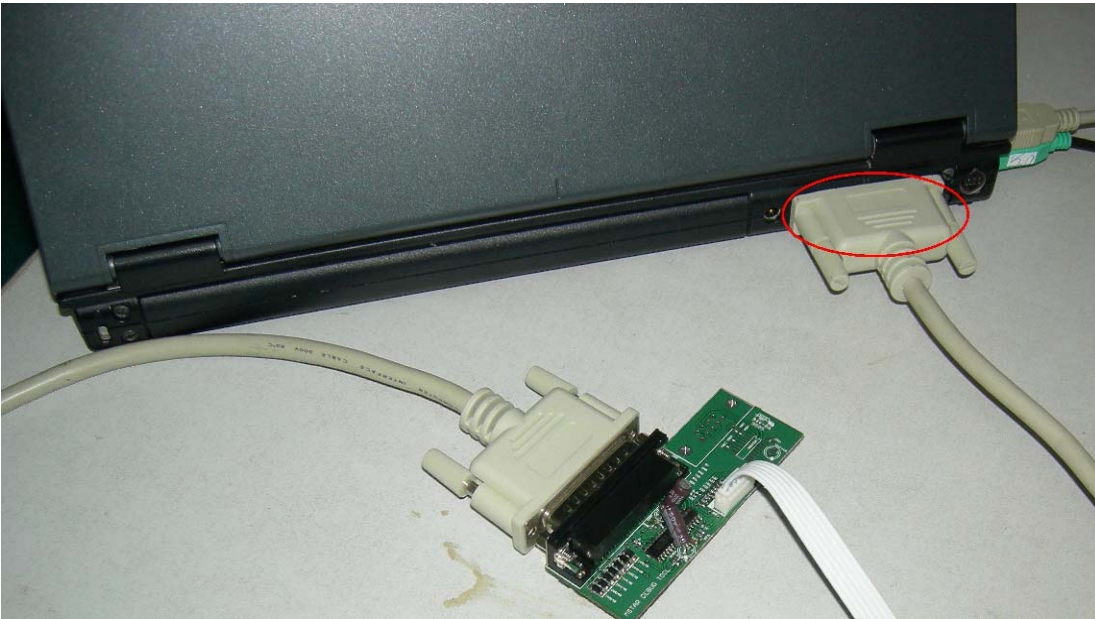

6.2 Upgrading with the ISP_TOOL4.0.9

6.2.1 Double click the ISP_TOOL4.0.9 icon and a dialog window will show as following.

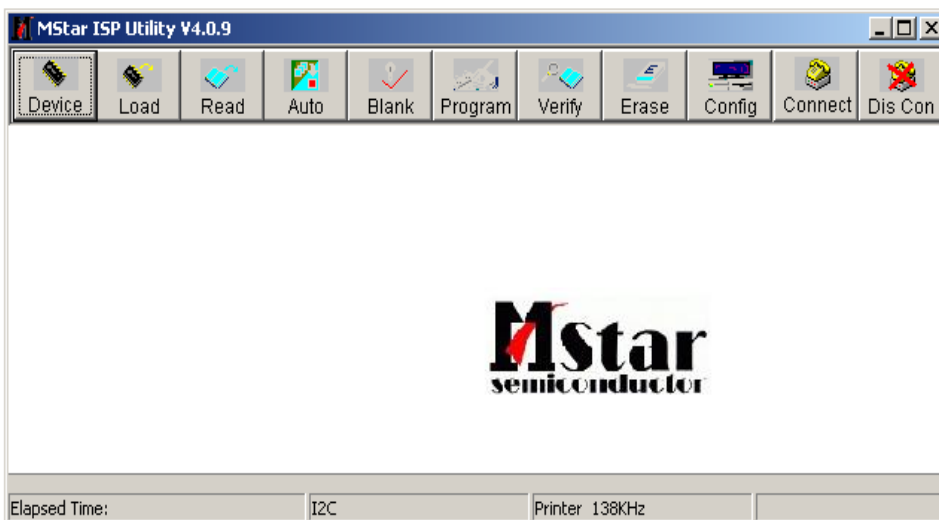

LCD TV Service Manual

Click the “Read ”button.

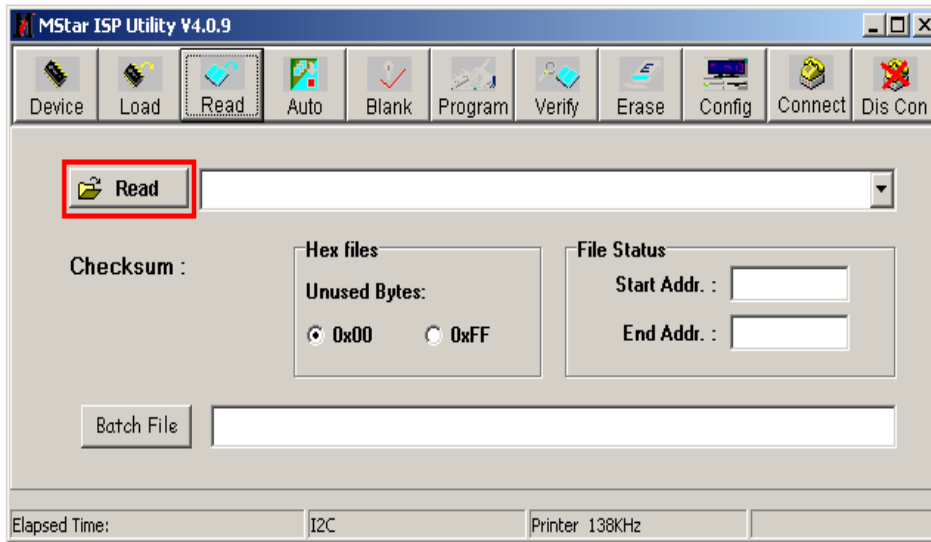

Choose the update file from the folder.

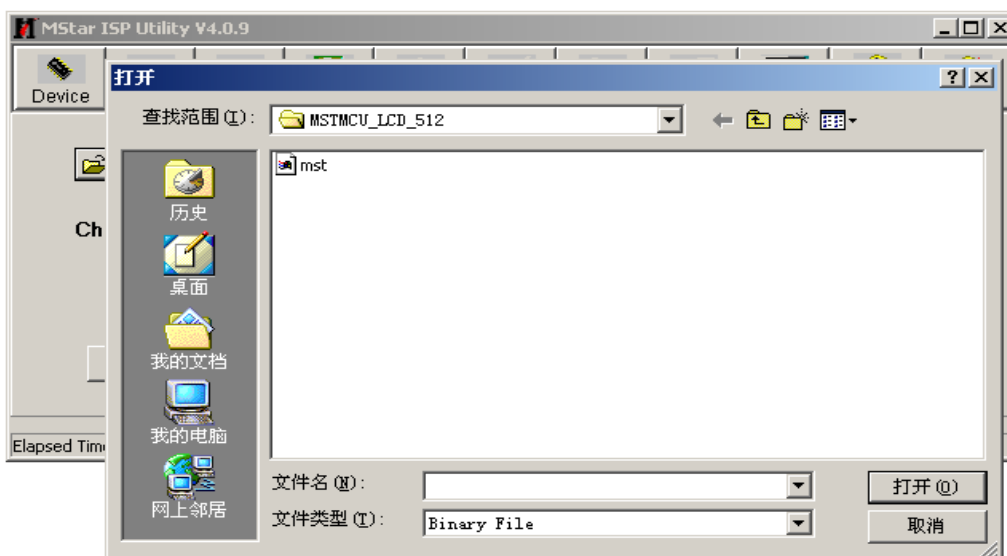

LCD TV Service Manual

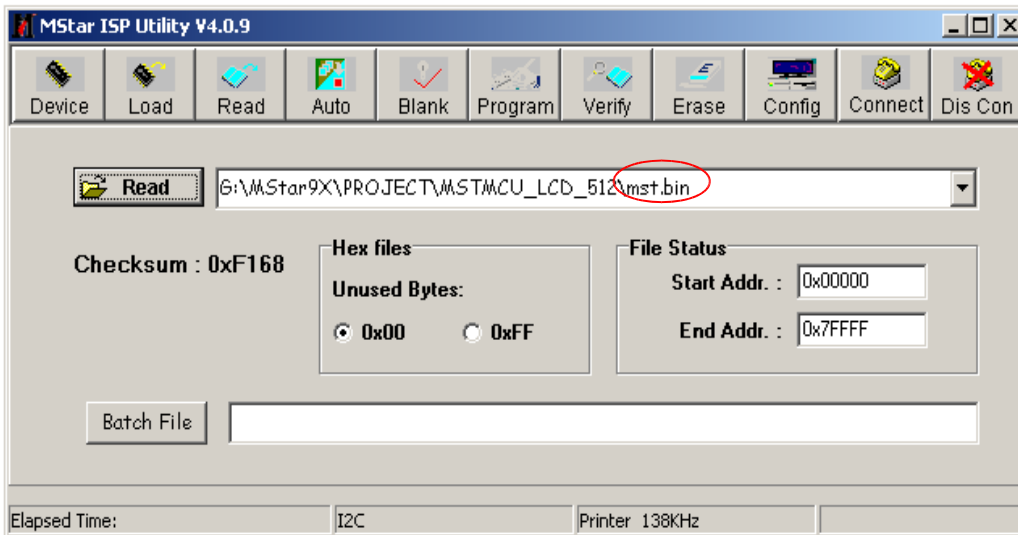
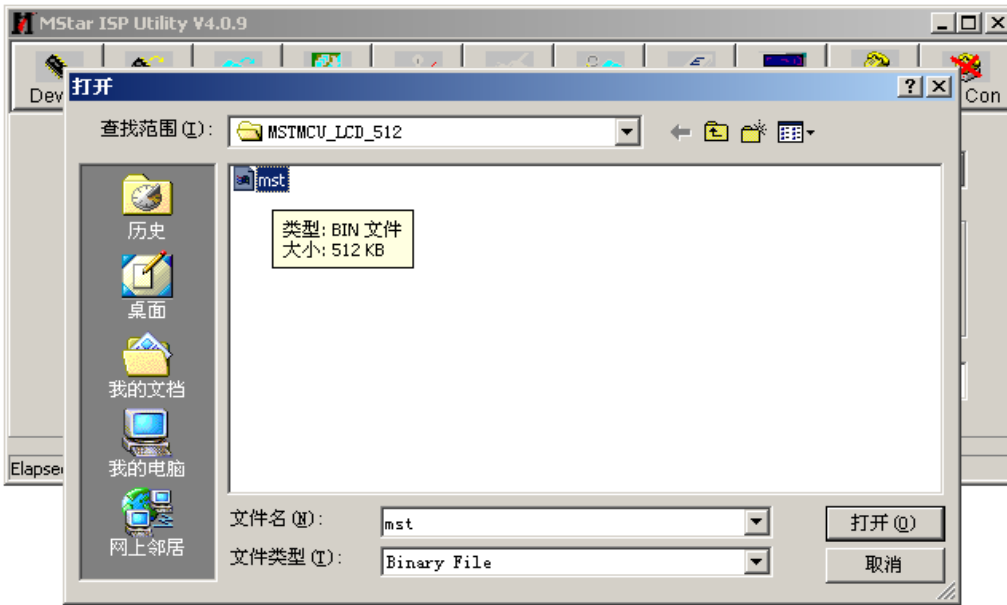

The update file has been chosen successfully。

Click the“Auto”button and choose parameters as following。

LCD TV Service Manual

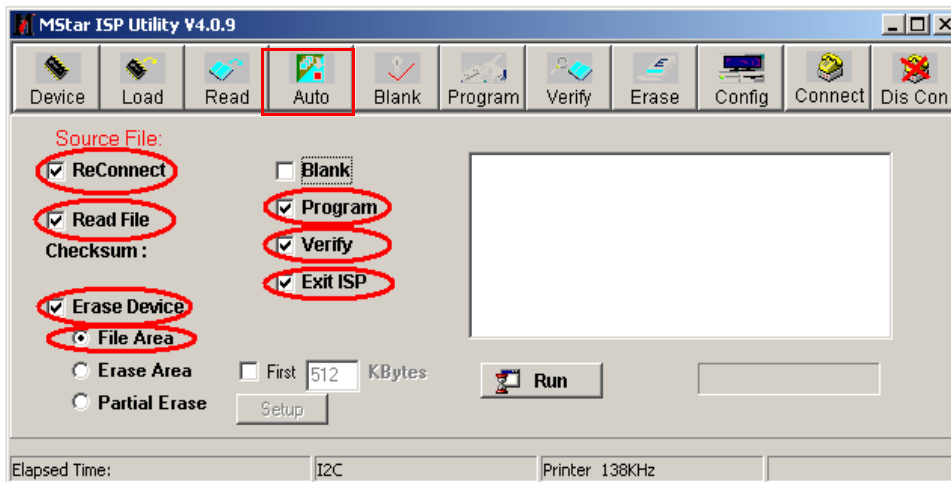

Click the“Run”button

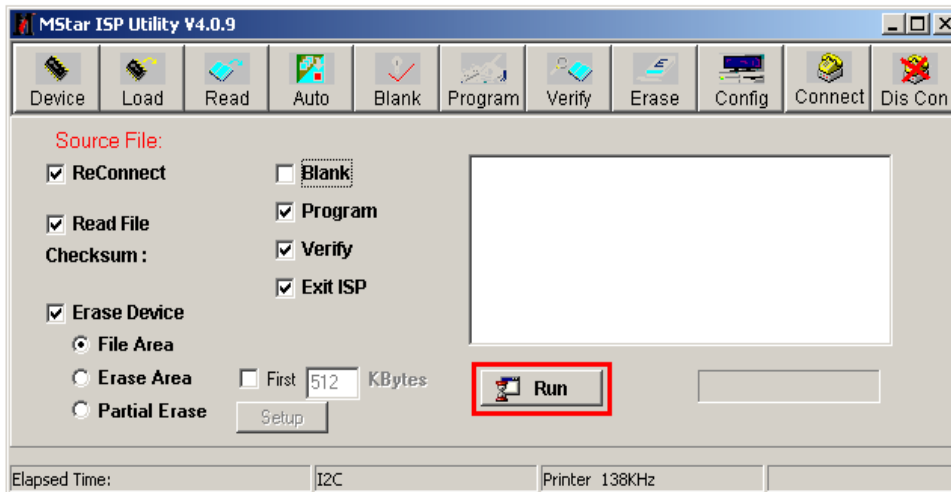

Click the“connect”button,then show a dialog box as following.

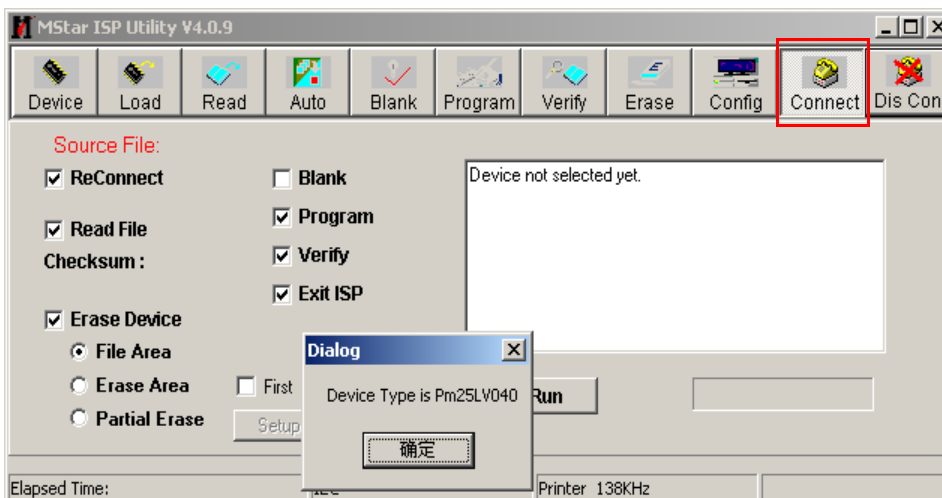

LCD TV Service Manual

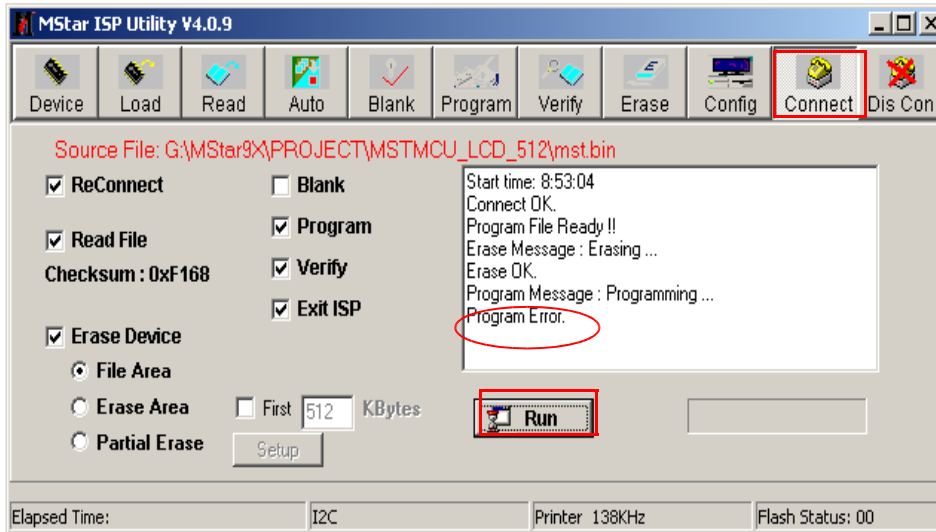

If show above then click the“Run”button again and again , till show the following dialog window.

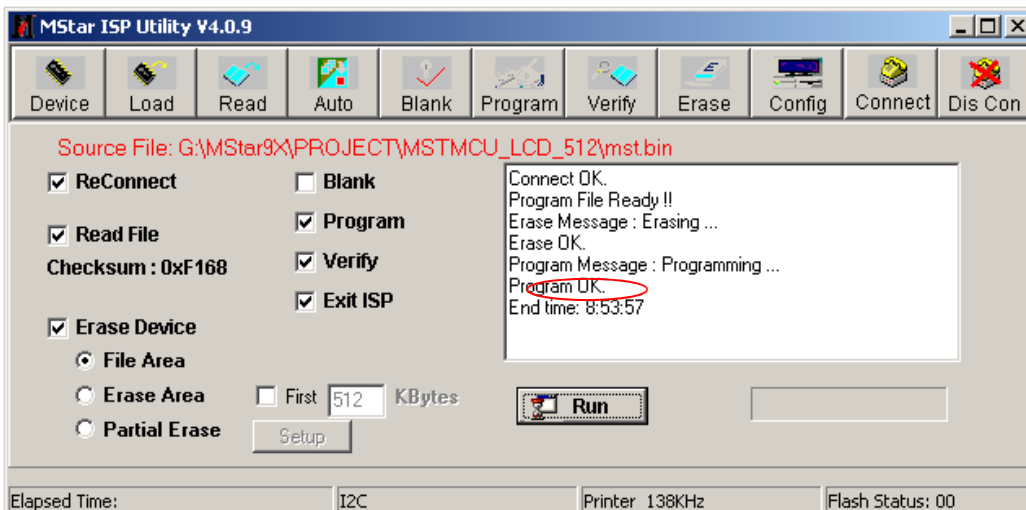
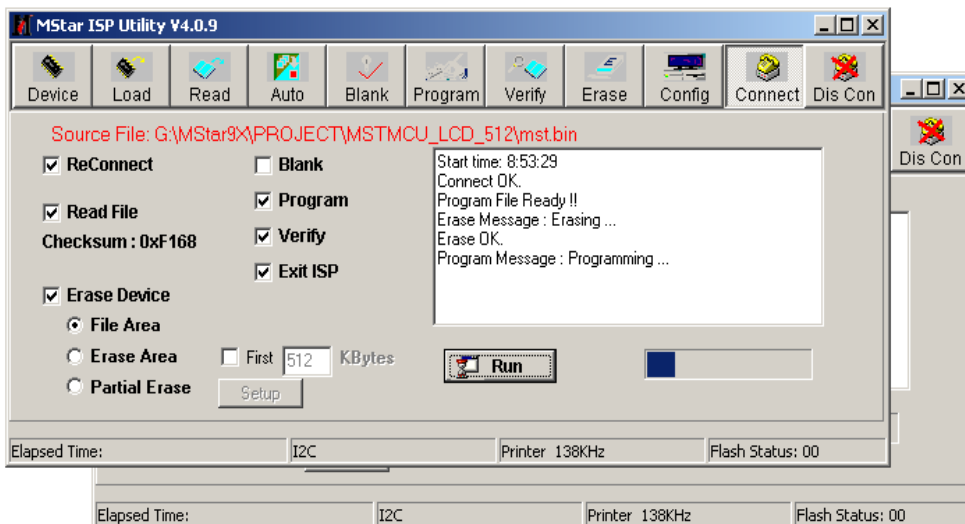

Hisense Confidential

The above appears on the screen-the word “program ok”shows in the information displaying window,indicating upgrading is over。

6.2.2 After the update is over. Must Confirm the software Version in the Version Menu.

If the update is successful, enter Factory Init Menu and select “Clear Unprotectly”

- a. Press VOL+ button to clear the EEPROM data.
- b. When the “Clear Unprotectly ” button becomes white, turn off the power.
- c. Restart the TV.

7. Troubleshooting

7.1 Troubleshooting for Remote Control

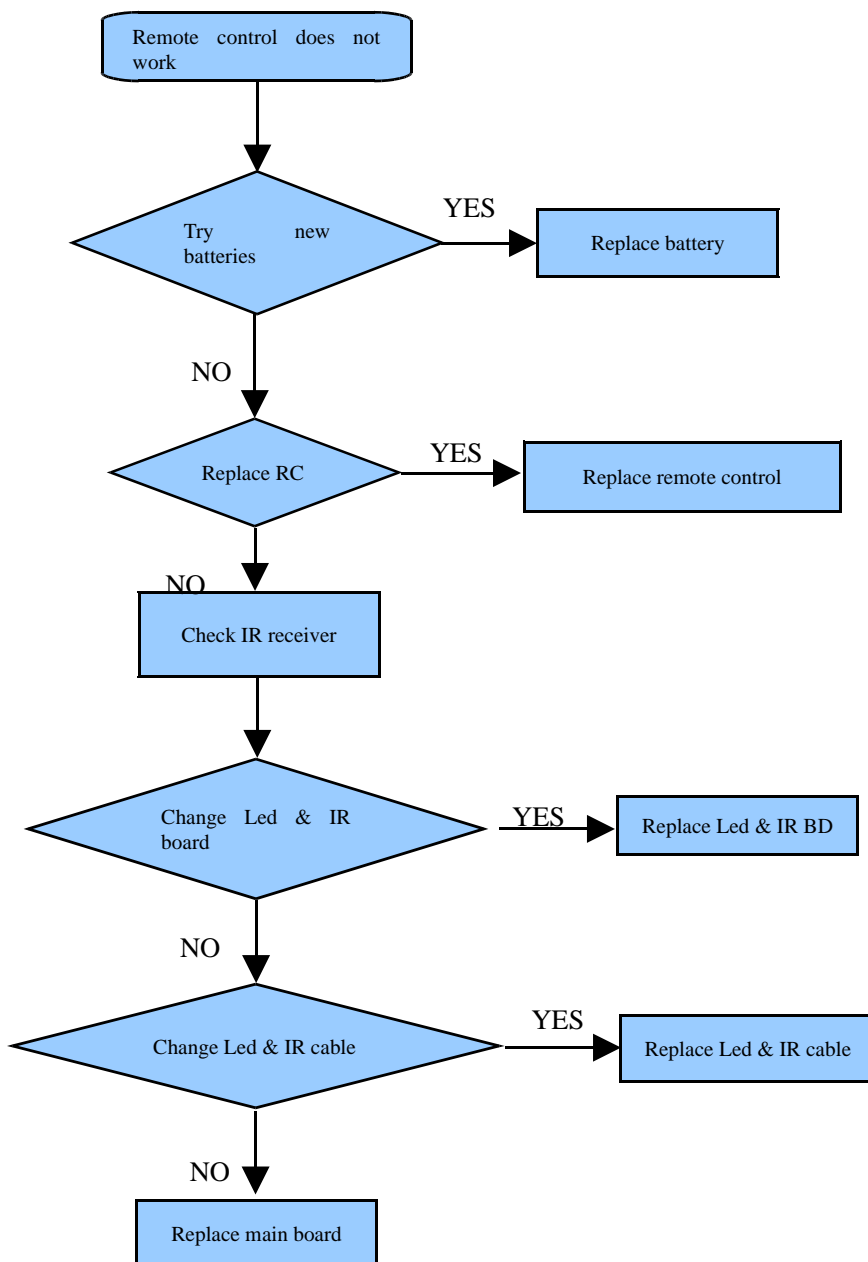

7.2 Troubleshooting for Function Key

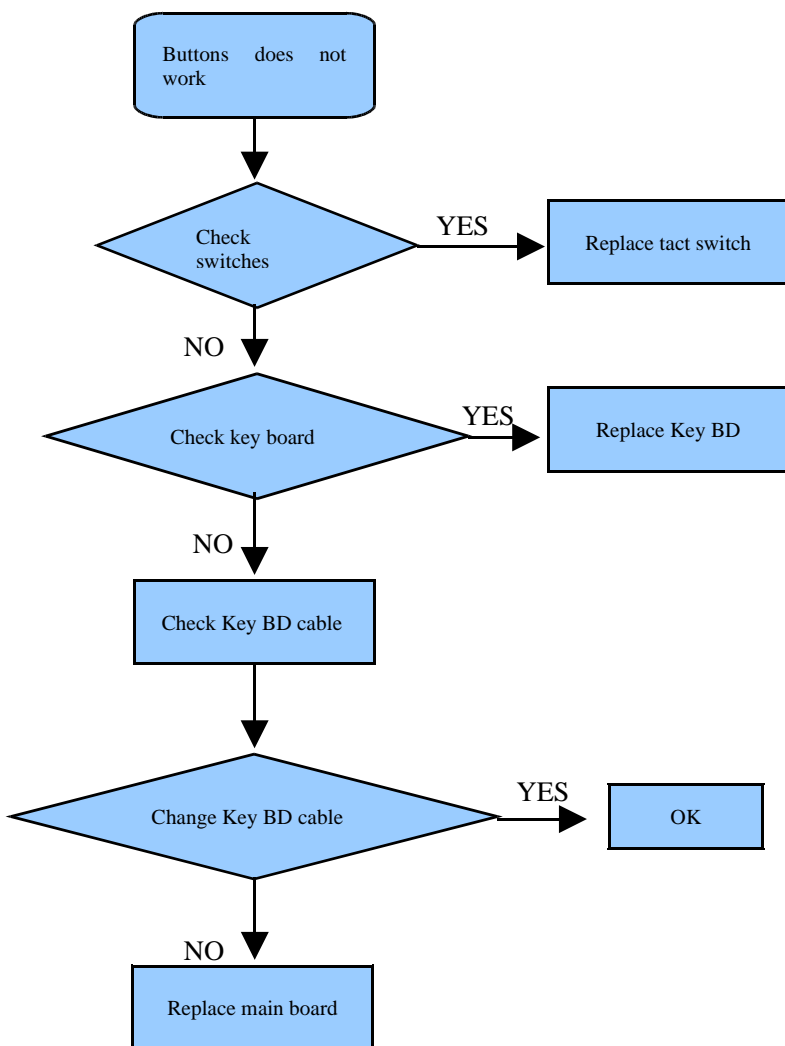

7.3 TV won't Power On

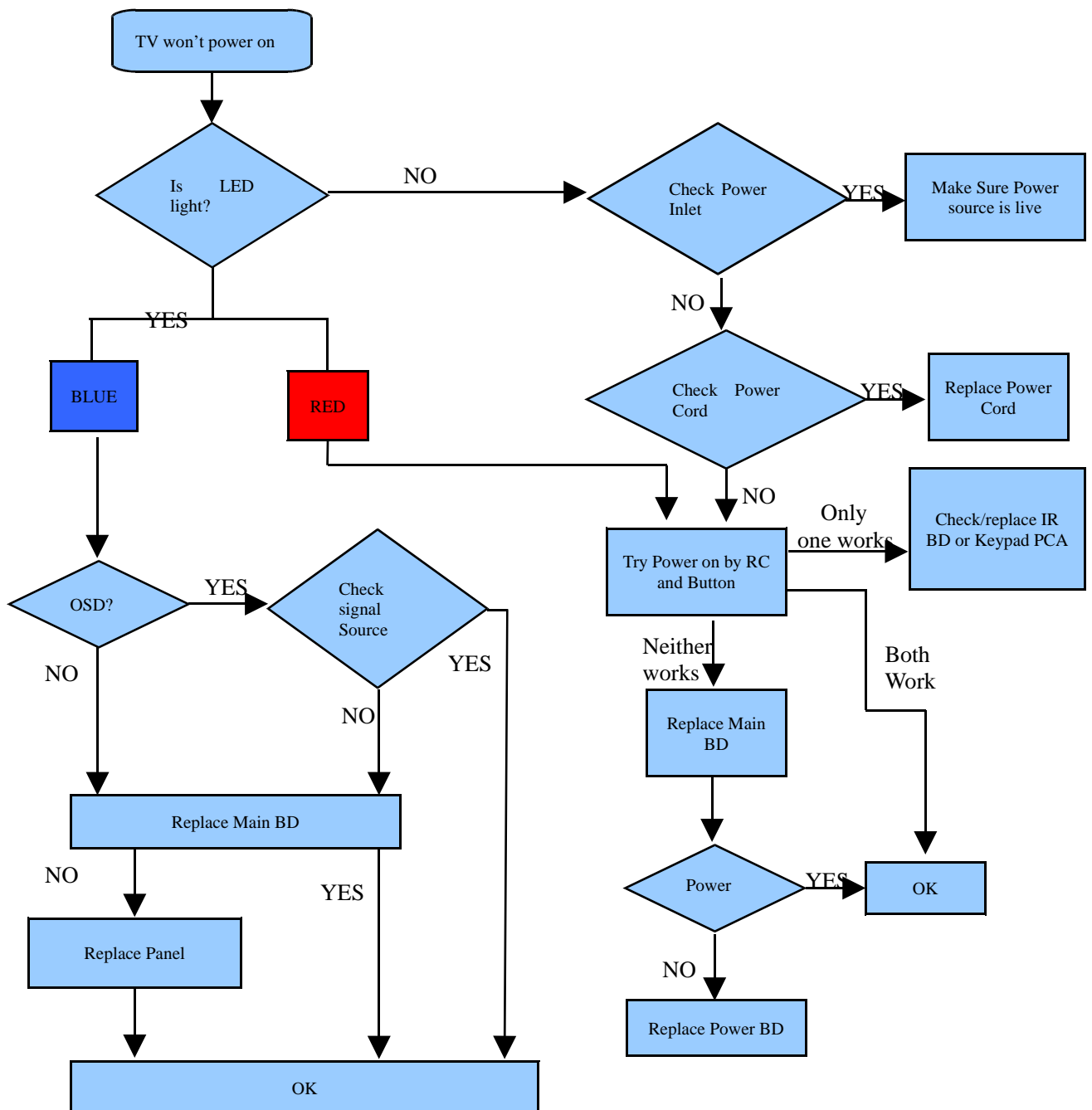

7.4 Troubleshooting for Audio

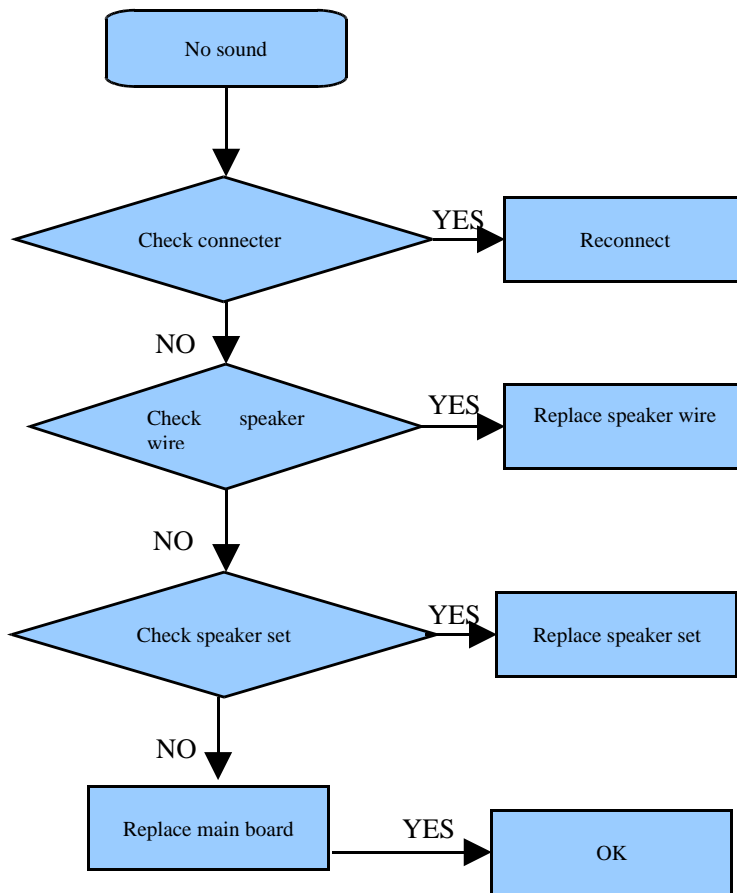

7.5 Troubleshooting for TV/VGA/HDMI input

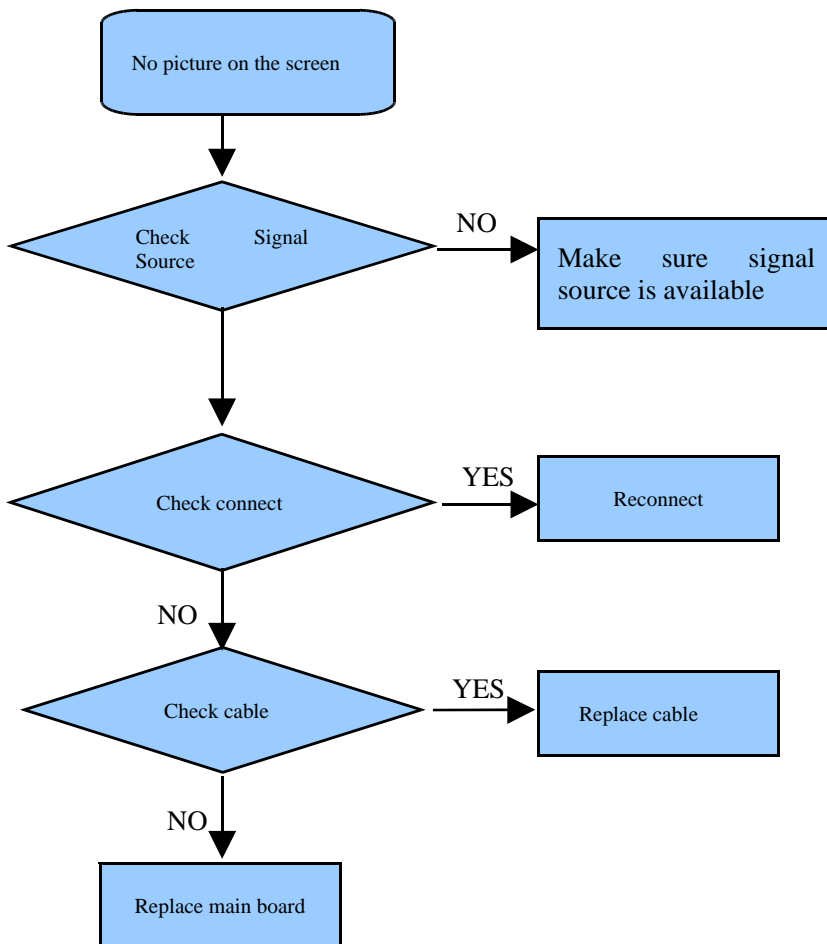

7.6 Troubleshooting for YPbPr input

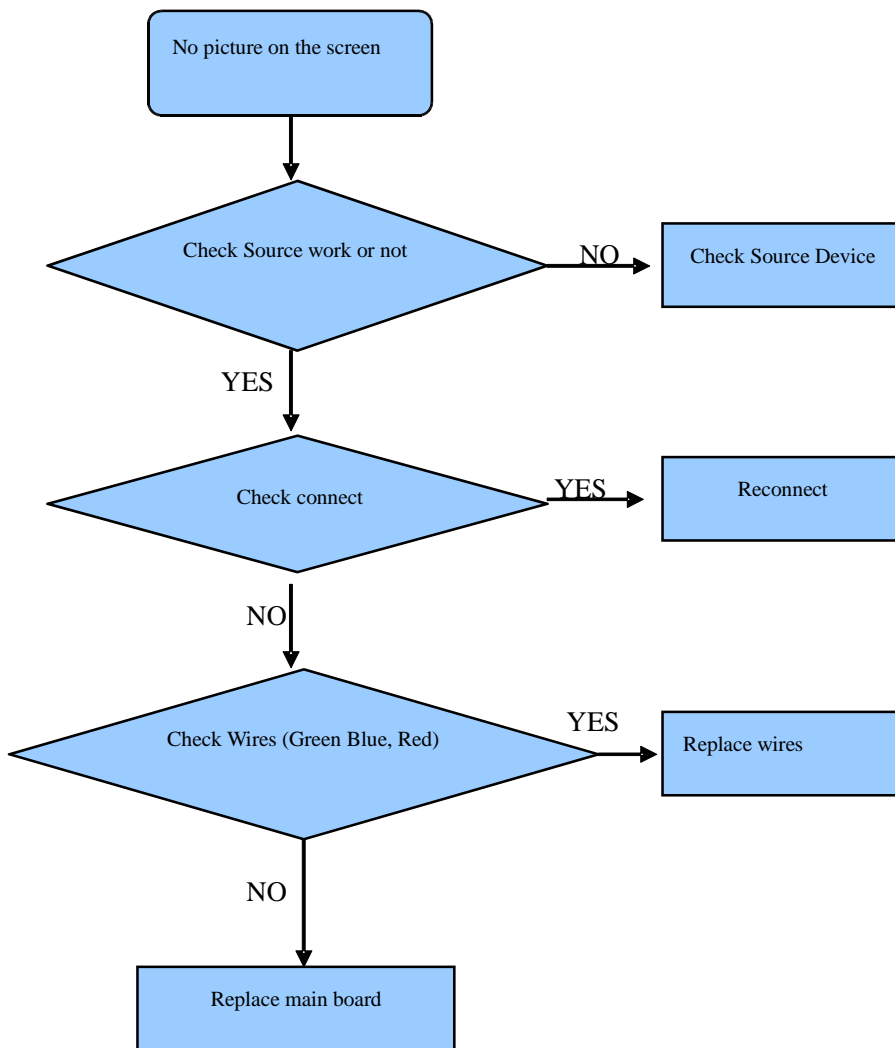

7.7 Troubleshooting for Video/S-Video input

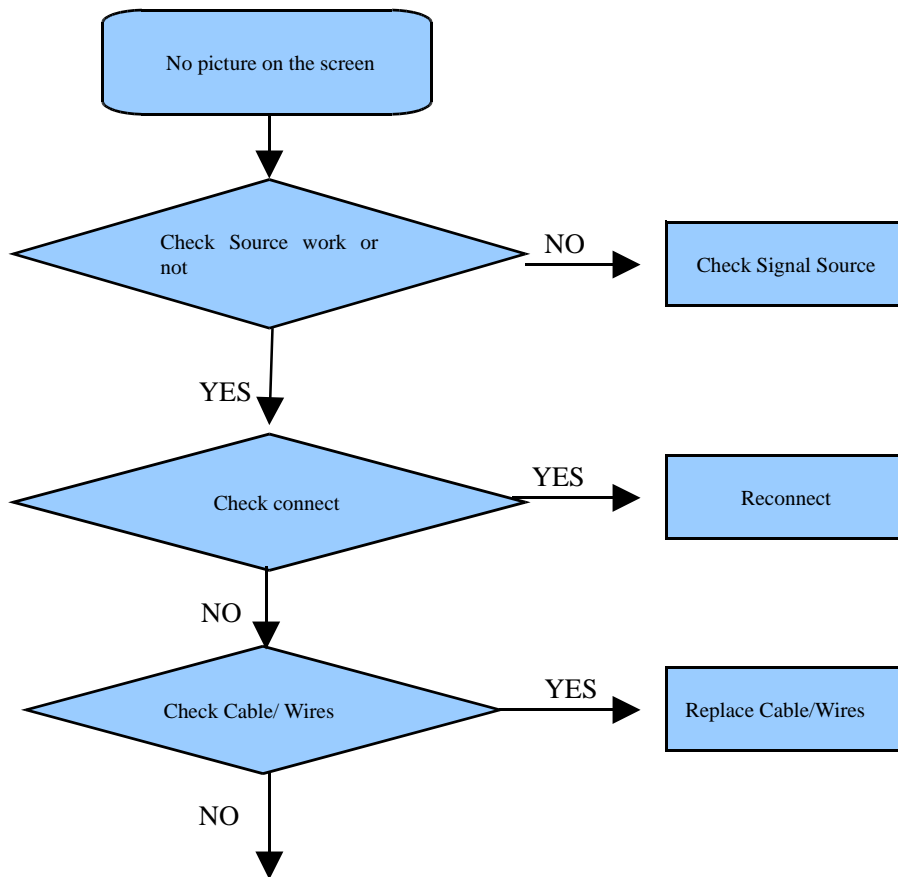

Replace main board

8. Explode View

9. Schematic circuit diagram

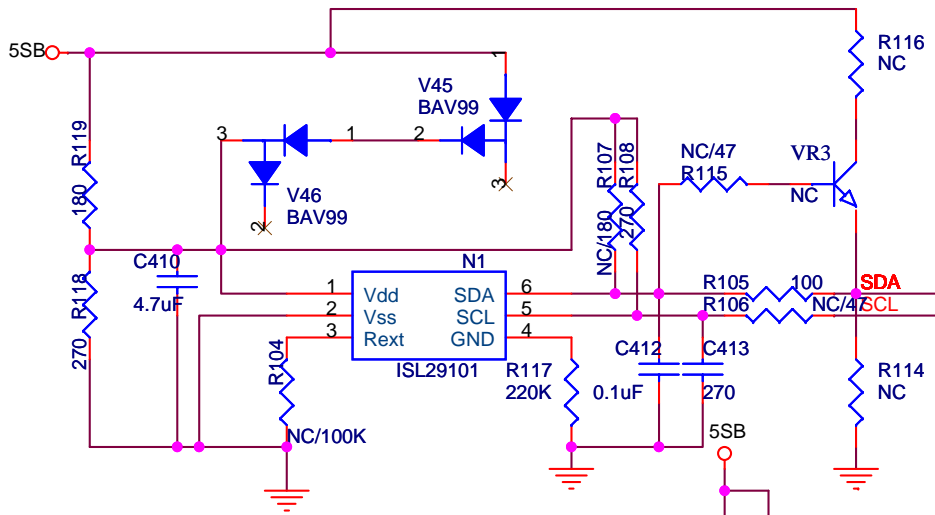
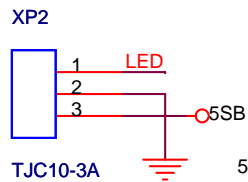
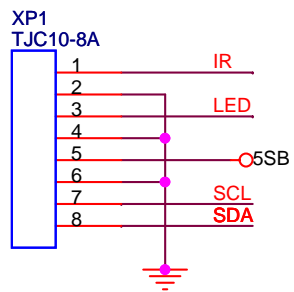

ISL29010数字光感: R104=0R R117=100K
 C412 C413=NC R108=NC R105 R106=47R
 原理图上的为模拟光感

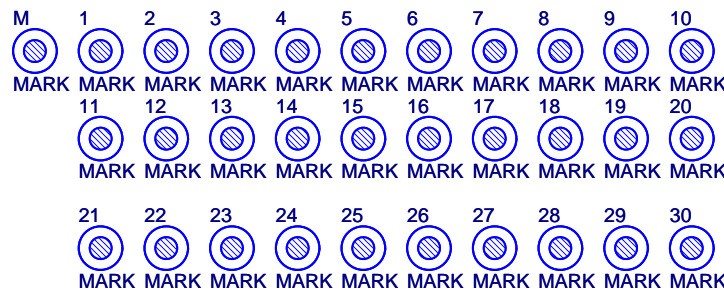
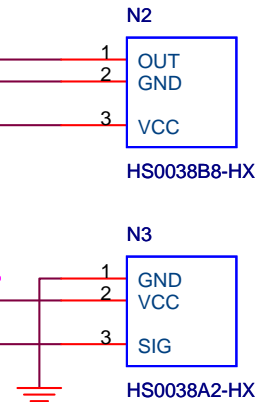
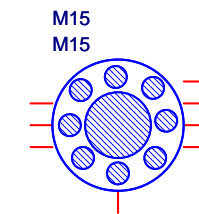
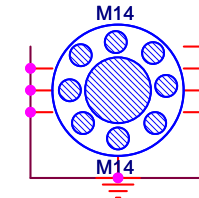
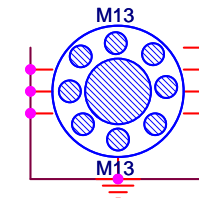
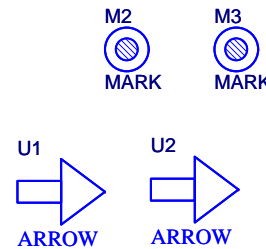
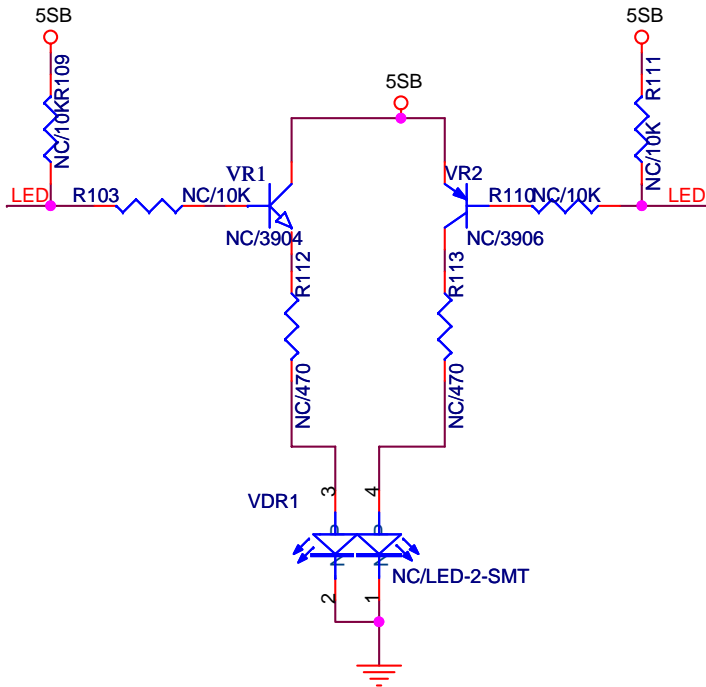

Title <Title>		
Size A	Document Number <Doc>	Rev <RevCode>
Date:	Tuesday, February 03, 2009	Sheet 1 of 1

TLM3237D

旧底图号

底图号

签名日期

格式①

工艺	数量	更改单号	姓名	日期	工艺	数量	更改单号	姓名	日期	工艺	数量	更改单号	姓名	日期
审核					审核					审核				
标准化					标准化					标准化				
批准					批准					批准				
TLM3237D_DY_A										等级标记 第 张 共 张				
制图:					插图:					幅面: A1				

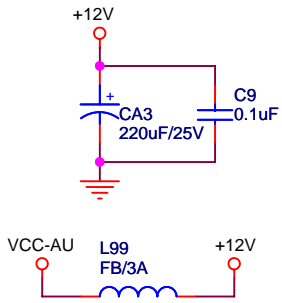
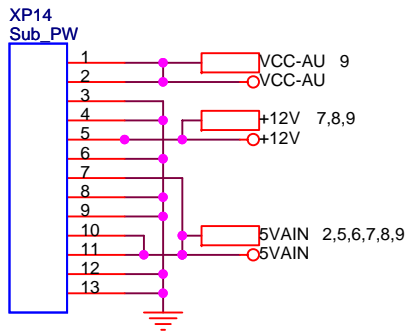
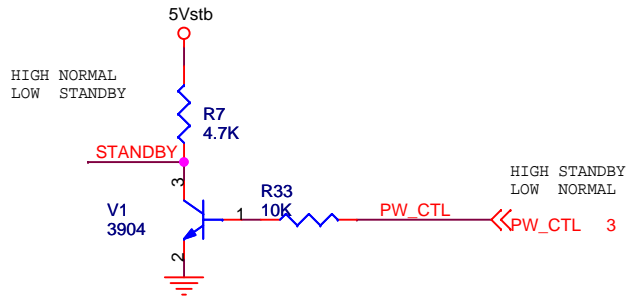
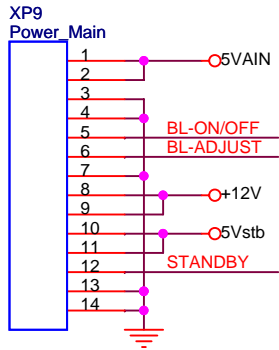

TO Inverter Board

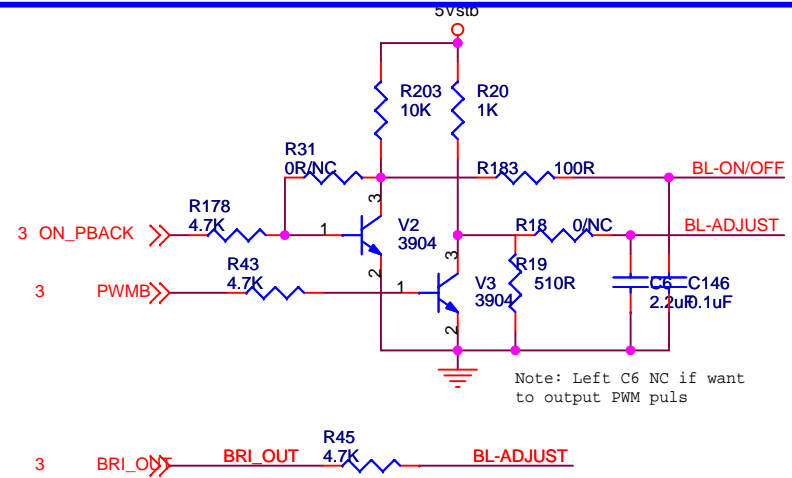

Power for Panel

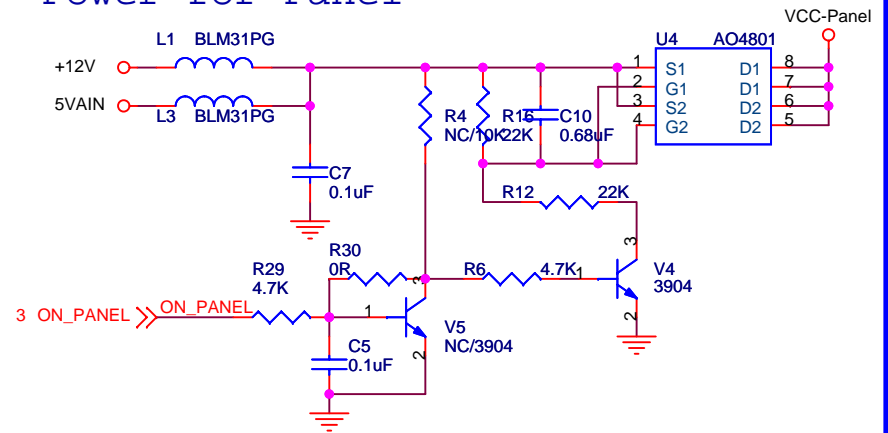

USB Power

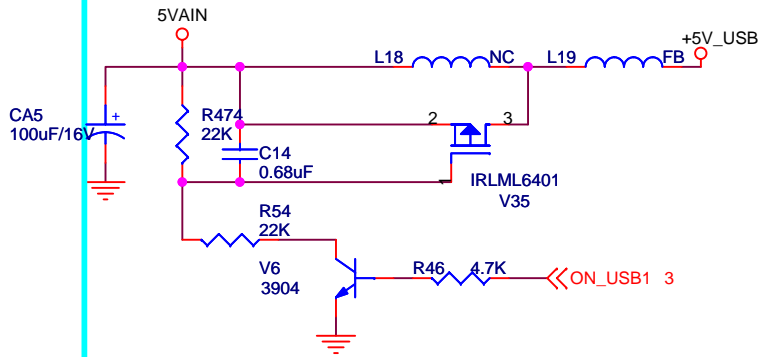

Title		<Title>
Size	Document Number	Rev
A4	MST6M16	<RevC>
Date:	Friday, April 10, 2009	Sheet 1 of 10

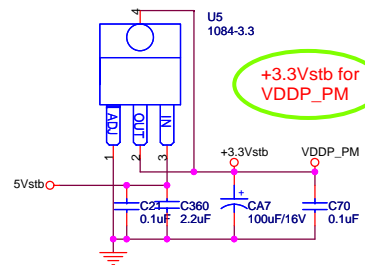

+3.3Vstb for VDDP_PM

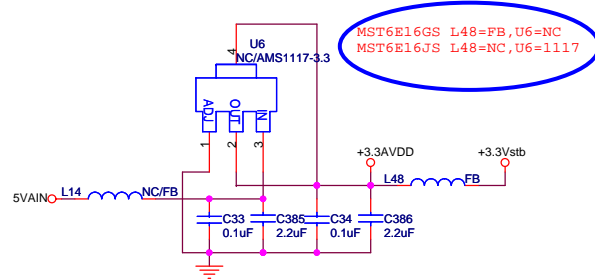

MST6E16GS L48=PB,U6=NC
MST6E16JS L48=NC,U6=1117

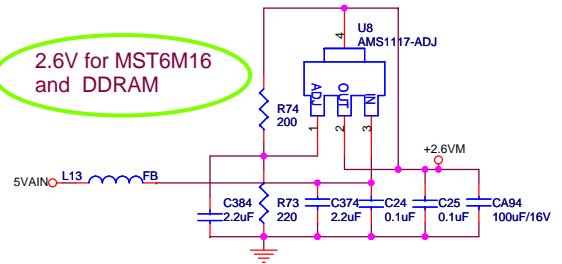

2.6V for MST6M16 and DDRAM

FOR use DDR,+2.6VM must be 2.6V
FOR use SDRAM,+2.6VM must be 3.3V

+3.3Vstb for AVDD_33

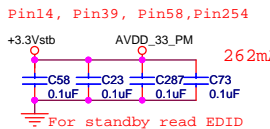

Pin14, Pin39, Pin58, Pin254

+3.3Vstb for VDD_MPLL

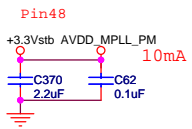

Pin48

+3.3AVDD for AVDD_MemPLL

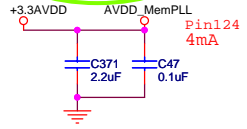

Pin124
4mA

Pin96, Pin166, Pin186,
Pin195, Pin202, Pin222,
Pin236,

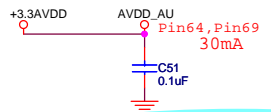
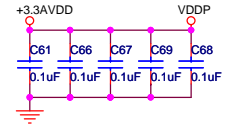

Pin64, Pin69
30mA

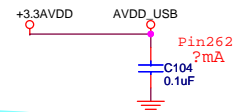

Pin262
?mA

+2.6V for MST6M16

Pin111, Pin127, Pin132,
Pin138, Pin143, Pin149,
Pin154

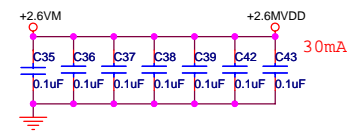

30mA

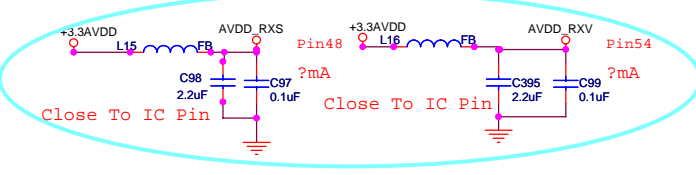

Close To IC Pin

Close To IC Pin

Vcc 1.26V for MST6M16 Core power

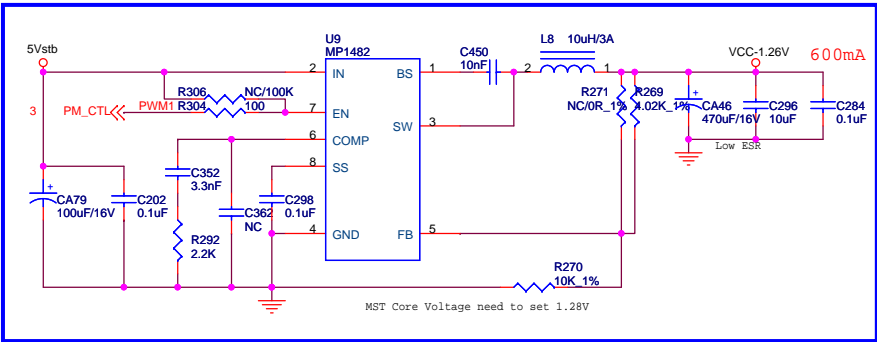

MST Core Voltage need to set 1.28V

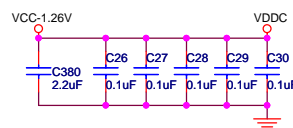

1.32V > VDDC > 1.26V, 最好在IC PIN脚有1.26V以上

Pin98, Pin109, Pin173,
Pin209, Pin242

注意: L7电流要大, 直流电阻要小,
保证VDDC到MST6M19GL的电压在1.26V

Mstar 深圳市高新区南区科技南十路国际技术创新研究院C座4楼
semiconductors TEL:0755-26996895 FAX:0755-26996830

Title power		Rev 01A
Size A3	Document Number MST6M19GL	
Date: Friday, April 10, 2009	Sheet 2	of 10

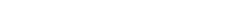
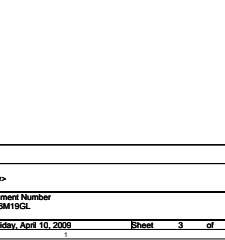
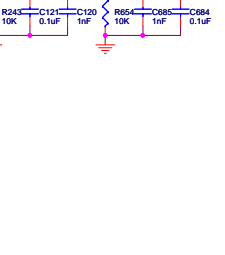
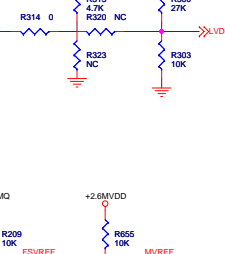
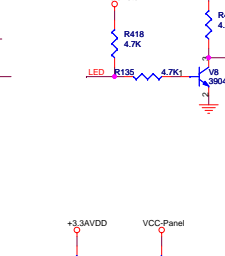
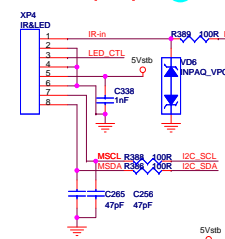
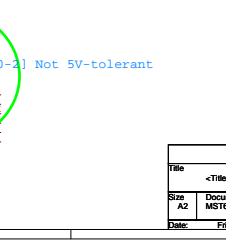
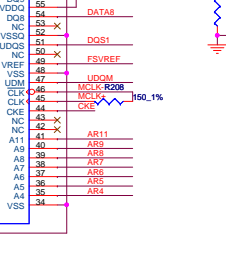
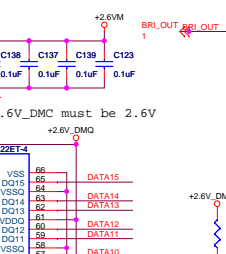
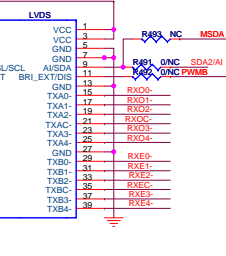
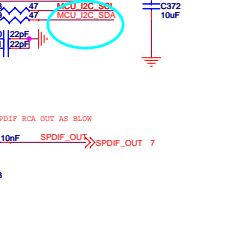
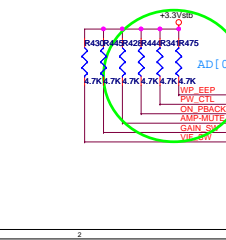
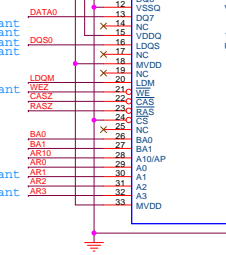
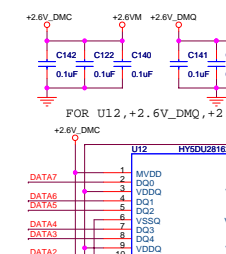
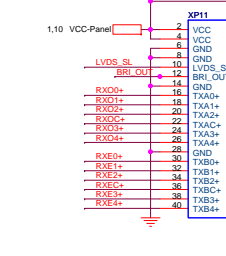
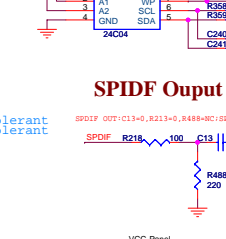
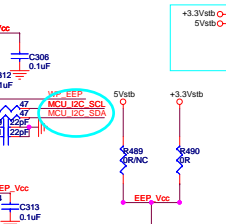
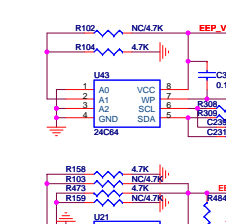
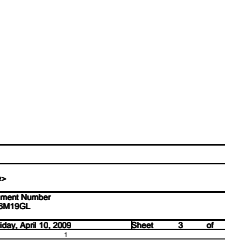
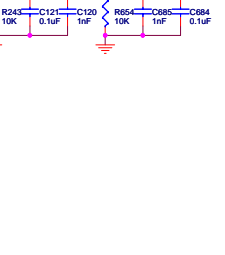
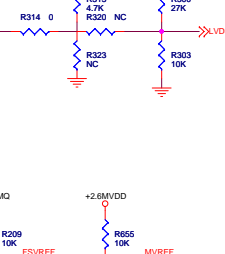
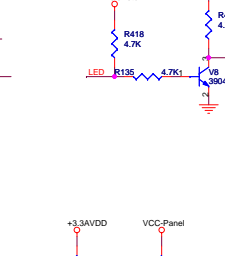
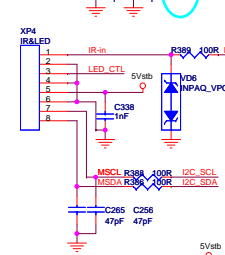
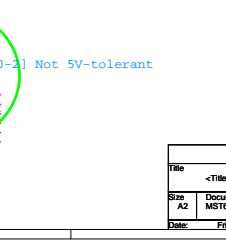
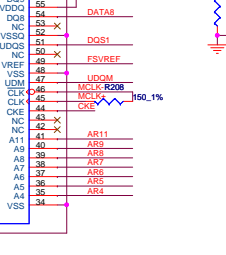
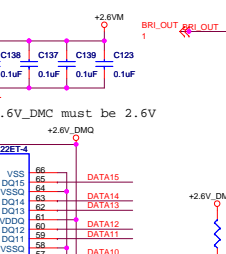
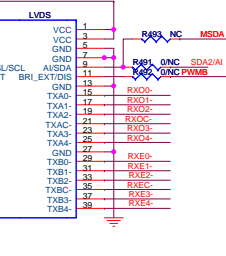
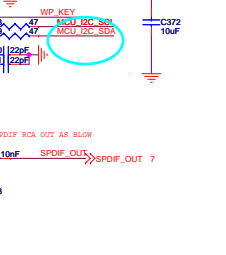
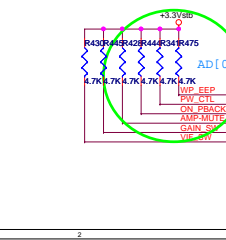
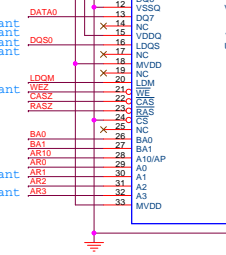
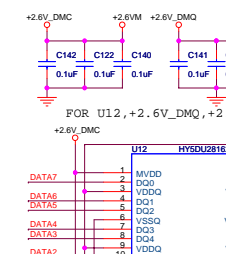
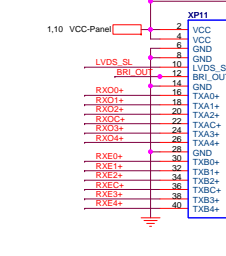
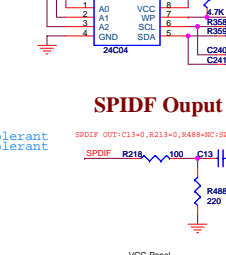
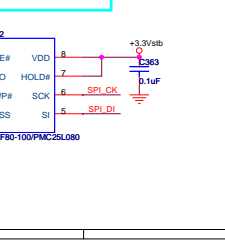
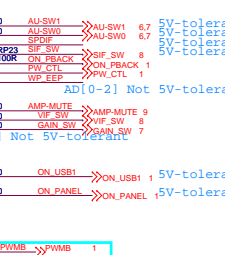
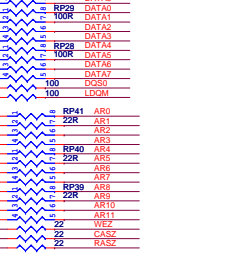
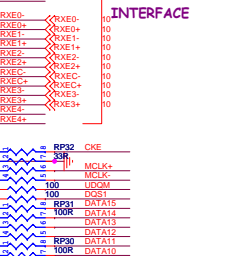
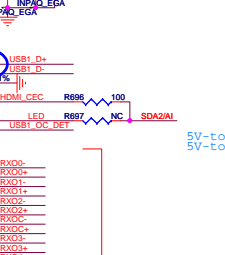
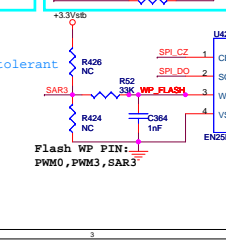
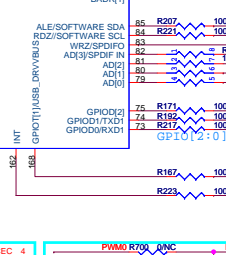
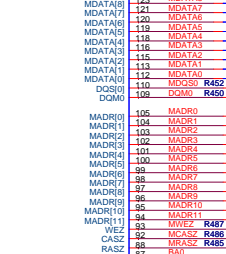
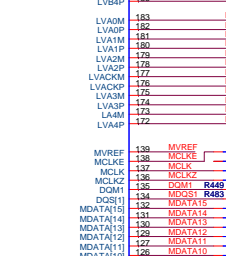
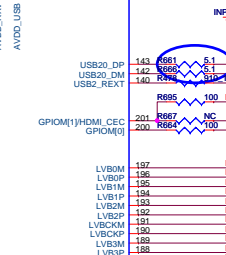
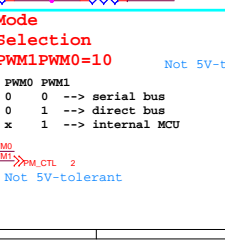
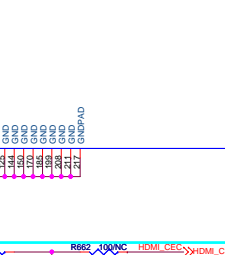
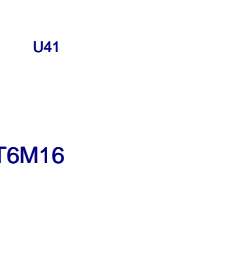
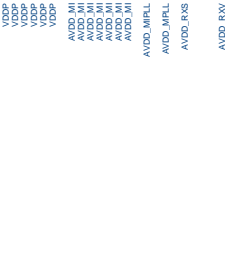
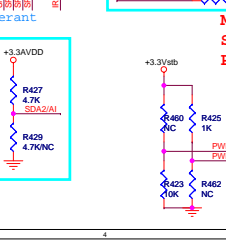
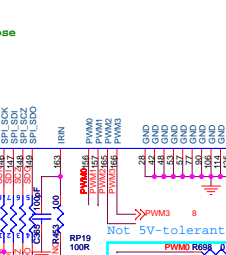
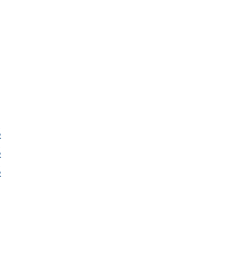
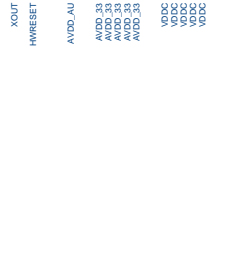
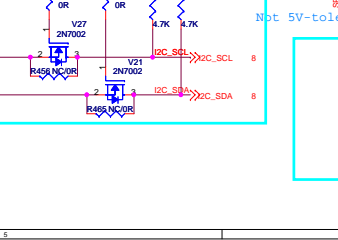
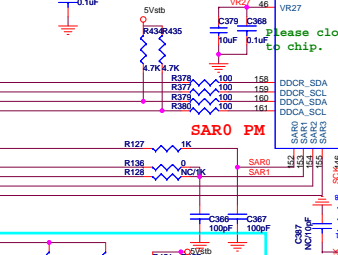
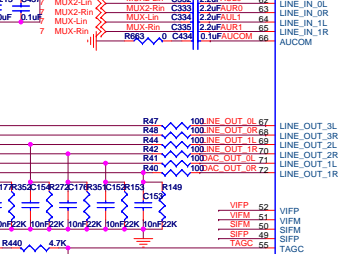
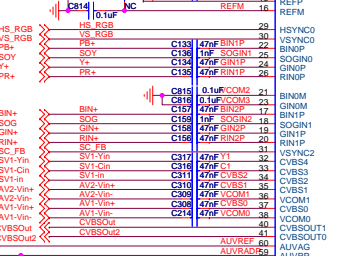
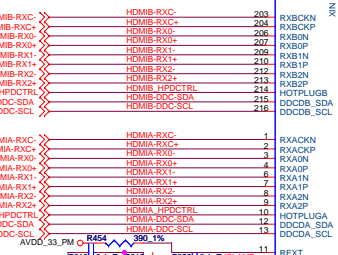
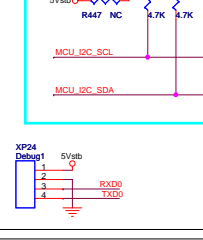
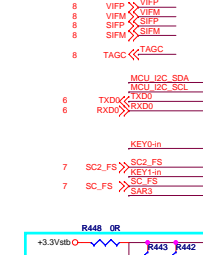
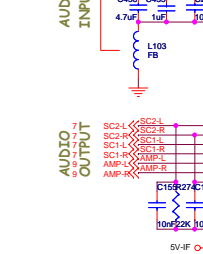
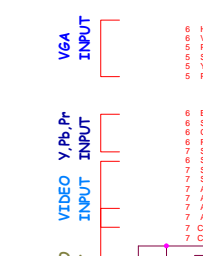
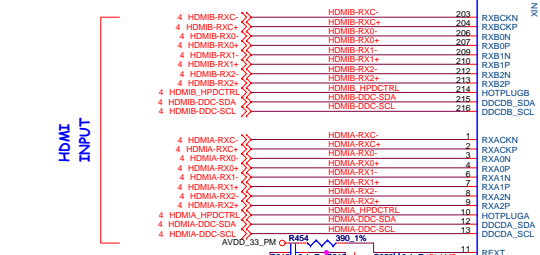
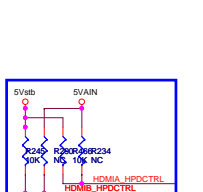
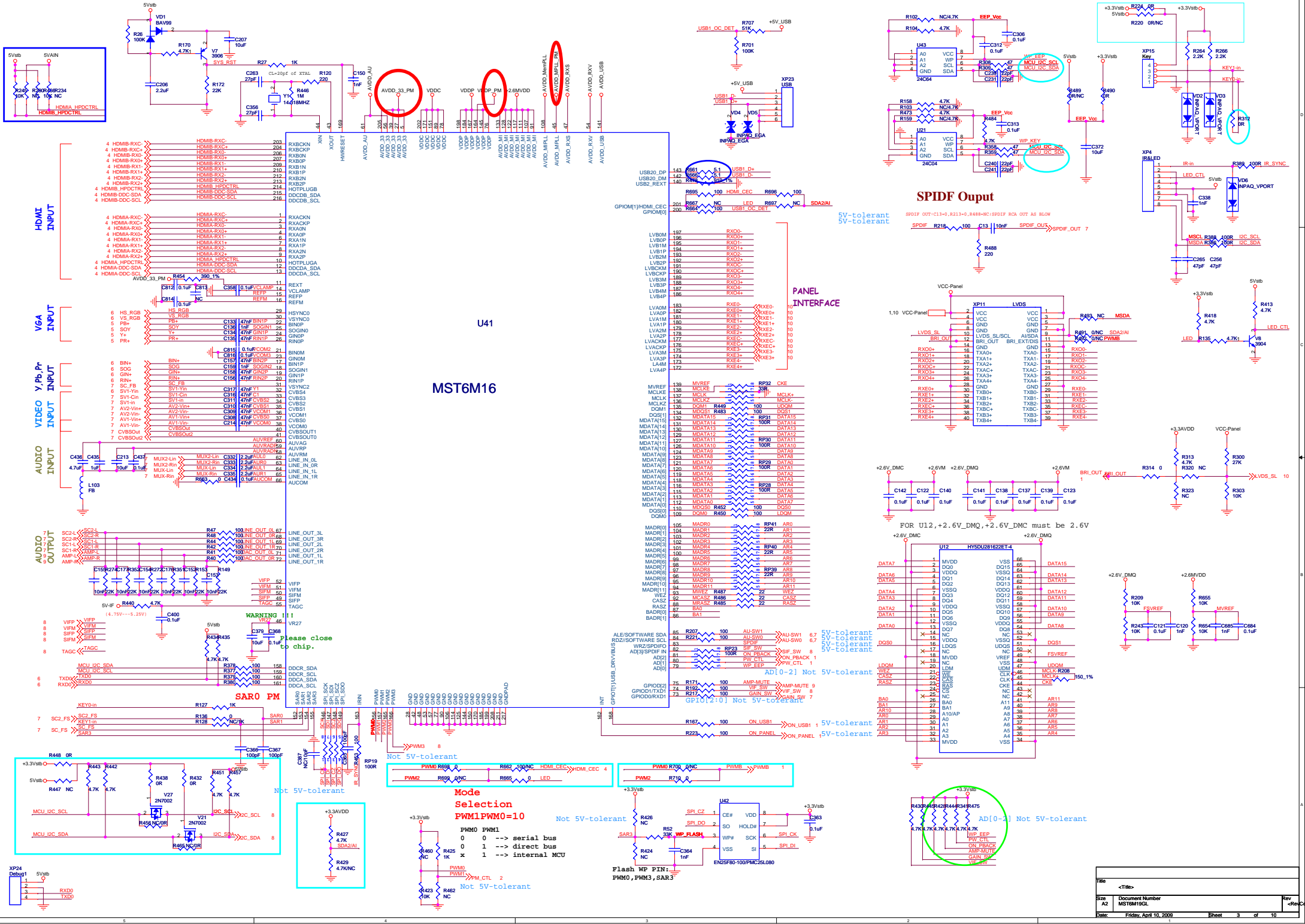
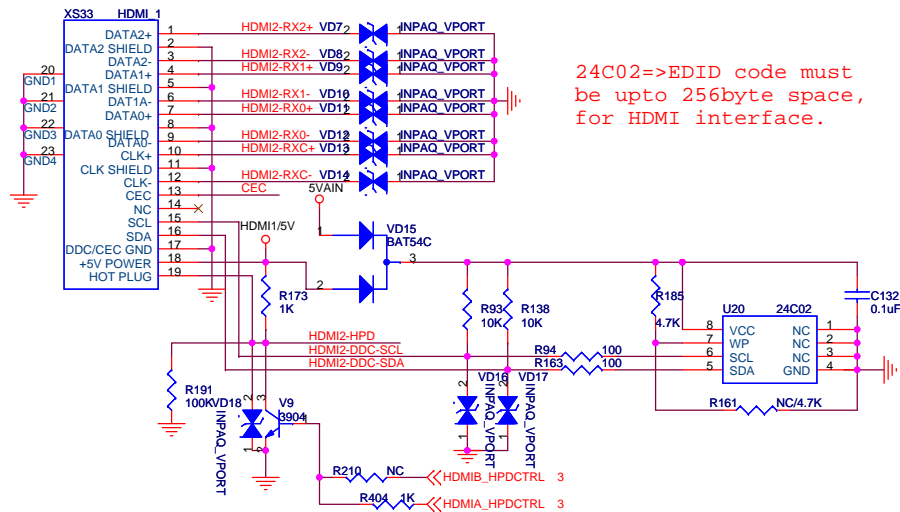
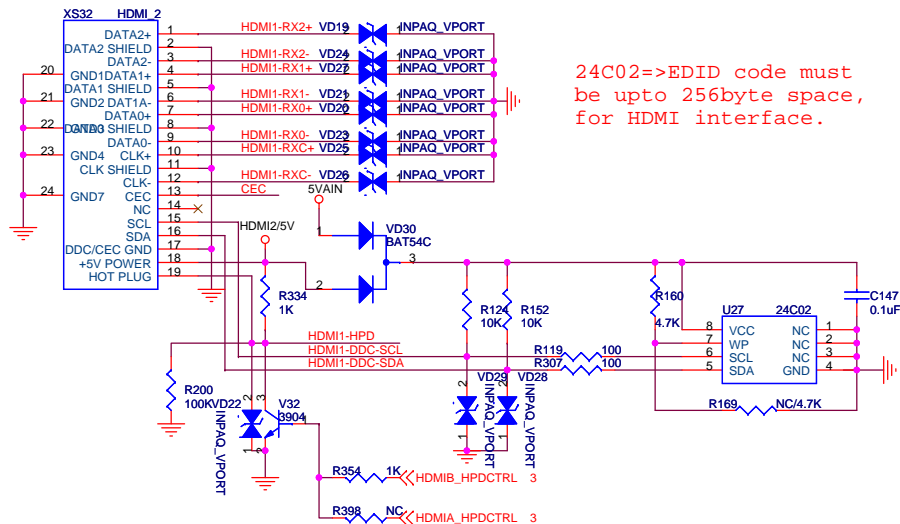

Table with 3 columns: File, Size, Date. Row 1: <Title>, 1.0K, Friday, April 10, 2009. Row 2: Document Number MST6M16CCL, 1.0K, Sheet 3 of 10. Row 3: Rev, <Rev>, <Rev>.



24C02=>EDID code must be upto 256byte space, for HDMI interface.

HDMI2-RX2+	R182	10	HDMI2-RX2+	HDMI2-RX2+	3
HDMI2-RX2-	R184	10	HDMI2-RX2-	HDMI2-RX2-	3
HDMI2-RX1+	R190	10	HDMI2-RX1+	HDMI2-RX1+	3
HDMI2-RX1-	R206	10	HDMI2-RX1-	HDMI2-RX1-	3
HDMI2-RX0+	R310	10	HDMI2-RX0+	HDMI2-RX0+	3
HDMI2-RX0-	R311	10	HDMI2-RX0-	HDMI2-RX0-	3
HDMI2-RX0+	R175	10	HDMI2-RX0+	HDMI2-RX0+	3
HDMI2-RXC+	R176	10	HDMI2-RXC+	HDMI2-RXC+	3
HDMI2-RXC-	R177	10	HDMI2-RXC-	HDMI2-RXC-	3
HDMI2-DDC-SCL	R177	100	HDMI2-DDC-SCL	HDMI2-DDC-SCL	3
HDMI2-DDC-SDA	R181	100	HDMI2-DDC-SDA	HDMI2-DDC-SDA	3



24C02=>EDID code must be upto 256byte space, for HDMI interface.

HDMI1-RX2+	R335	10	HDMI1-RX2+	HDMI1-RX2+	3
HDMI1-RX2-	R336	10	HDMI1-RX2-	HDMI1-RX2-	3
HDMI1-RX1+	R337	10	HDMI1-RX1+	HDMI1-RX1+	3
HDMI1-RX1-	R342	10	HDMI1-RX1-	HDMI1-RX1-	3
HDMI1-RX0+	R355	10	HDMI1-RX0+	HDMI1-RX0+	3
HDMI1-RX0-	R356	10	HDMI1-RX0-	HDMI1-RX0-	3
HDMI1-RX0+	R180	10	HDMI1-RX0+	HDMI1-RX0+	3
HDMI1-RXC+	R231	10	HDMI1-RXC+	HDMI1-RXC+	3
HDMI1-RXC-	R332	100	HDMI1-RXC-	HDMI1-RXC-	3
HDMI1-DDC-SCL	R333	100	HDMI1-DDC-SCL	HDMI1-DDC-SCL	3
HDMI1-DDC-SDA	R333	100	HDMI1-DDC-SDA	HDMI1-DDC-SDA	3

For CEC Leakage Protect

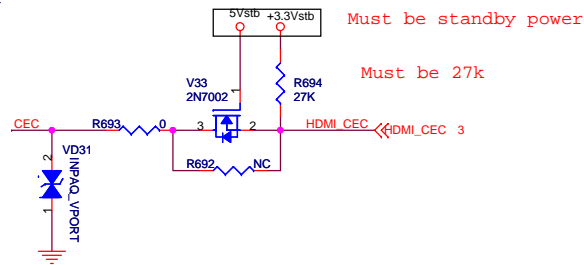

Must be standby power

Must be 27k

SCART1 RGB Input

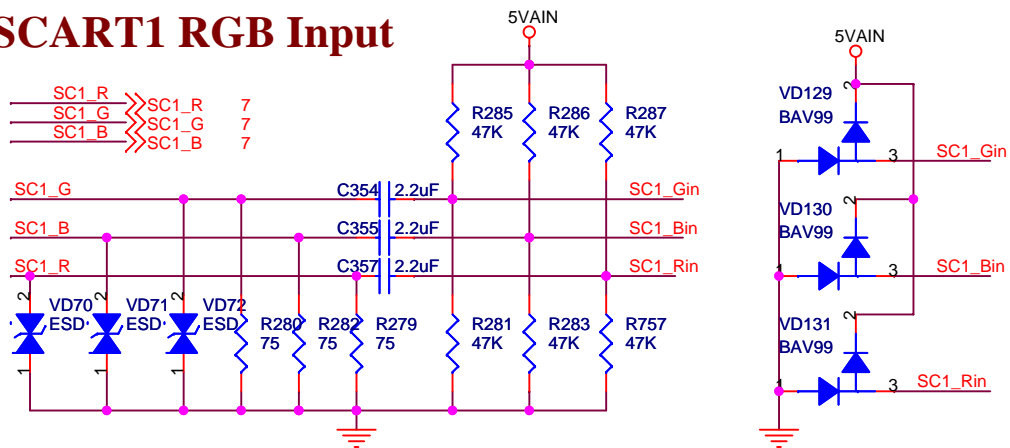



 深圳市高新区南区科技南十路国际技术创新研究院C座4楼
 TEL:0755-26996895 FAX:0755-26996830

Title		VGA	
Size	Document Number	Rev	
A4	MST6M16	01A	
Date:	Friday, April 10, 2009	Sheet	5 of 10

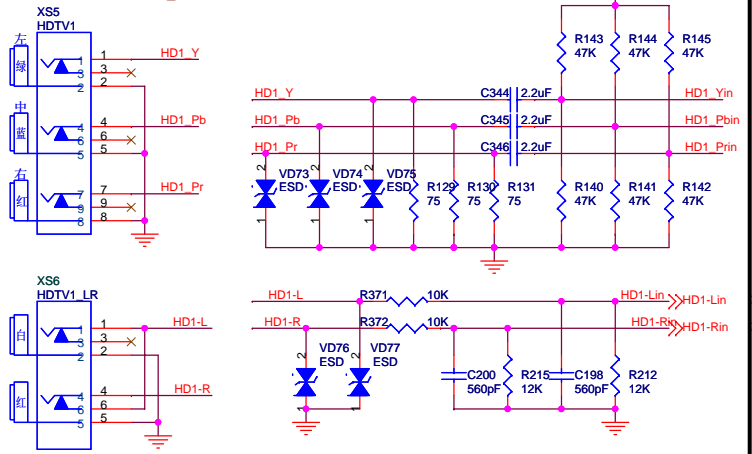
HDTV1 Input

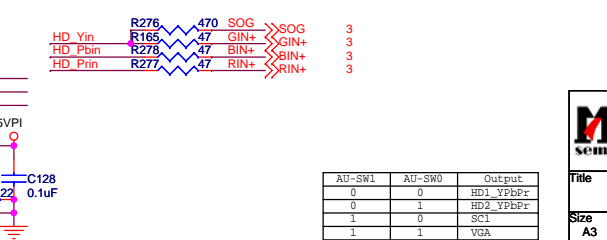
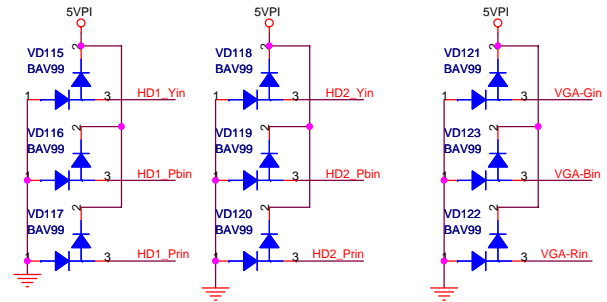
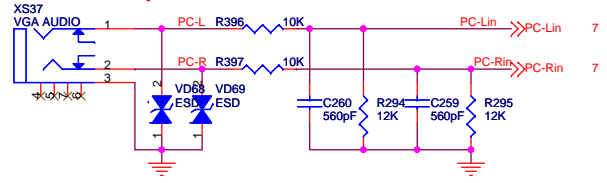
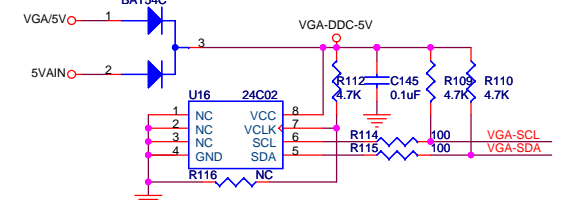
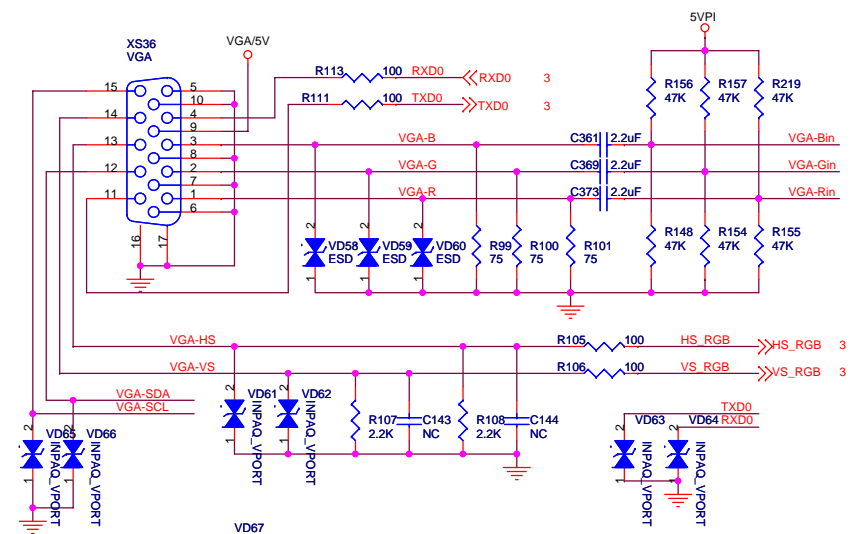
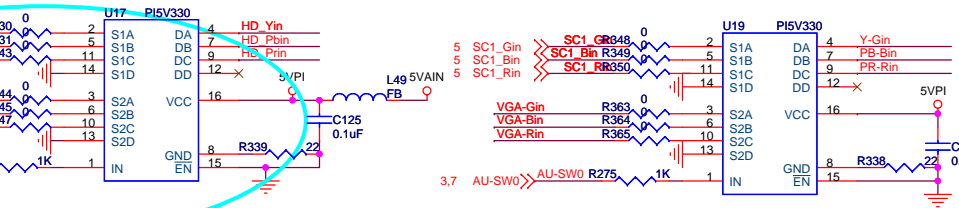
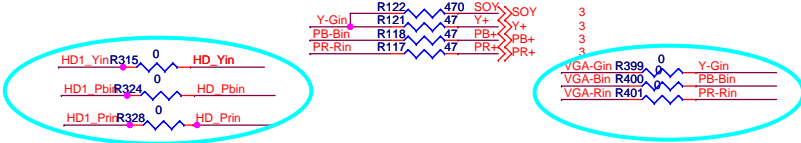
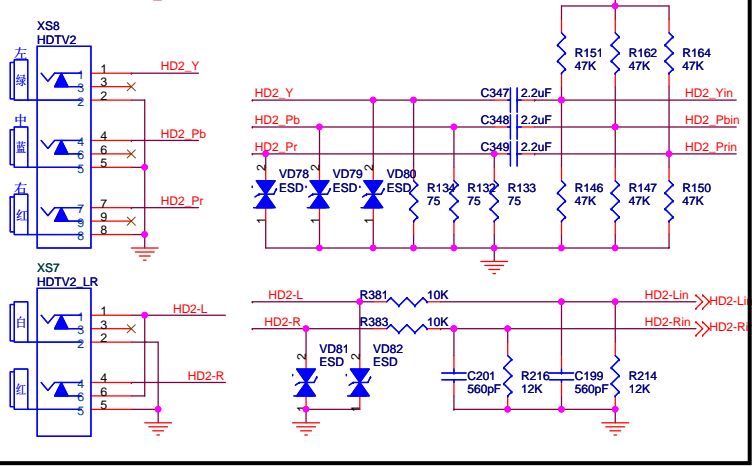

HDTV2 Input



AU-SW1	AU-SW0	Output
0	0	HD1_VpPPr
0	1	HD2_VpPPr
1	0	SC1
1	1	VGA

Mstar semiconductor

深圳市高新区南区科技南十路国际技术创新研究院C座4楼

TEL:0755-26996895 FAX:0755-26996830

Title: Y,Pb,Pr Input

Size A3 Document Number MST6M16 Rev 01A

Date: Friday, April 10, 2009 Sheet 6 of 10

AV1 Input

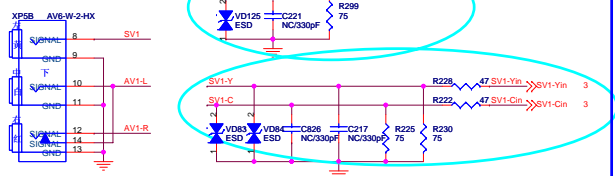

S-Video Input

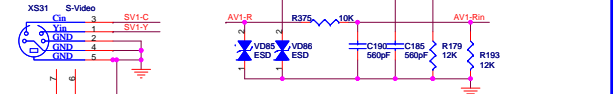

AV Output

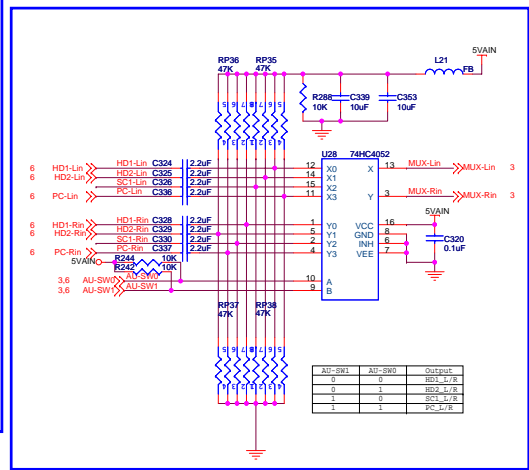
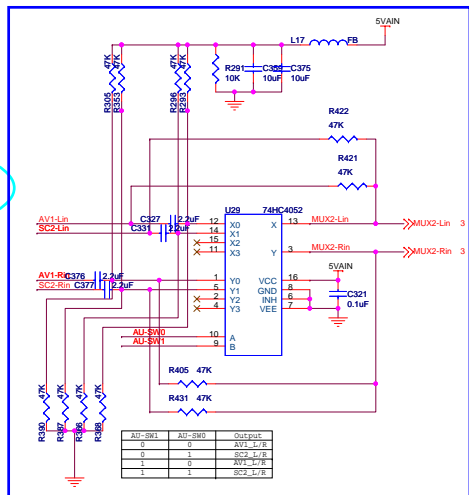
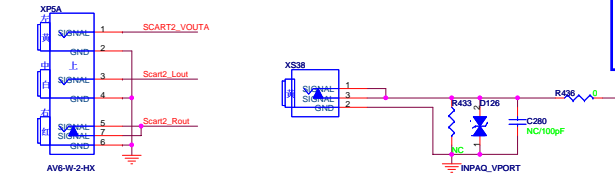

SCART1 Input

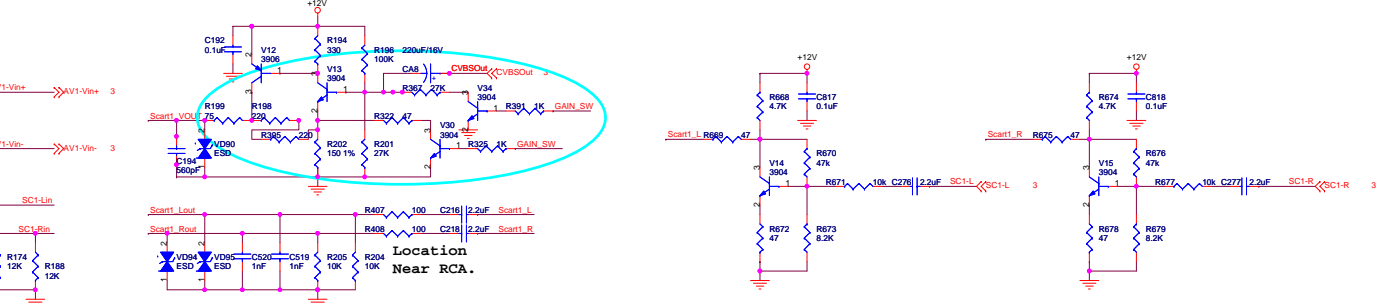
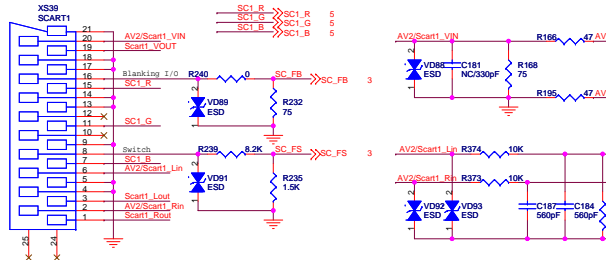

SCART2 Input

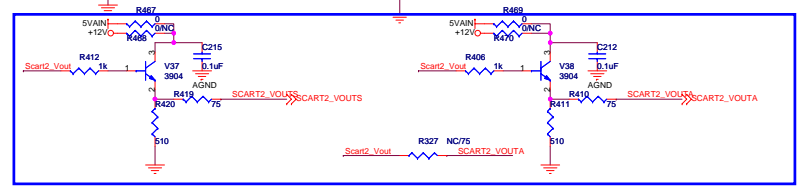
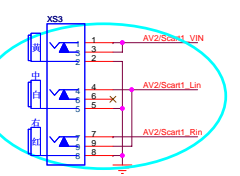
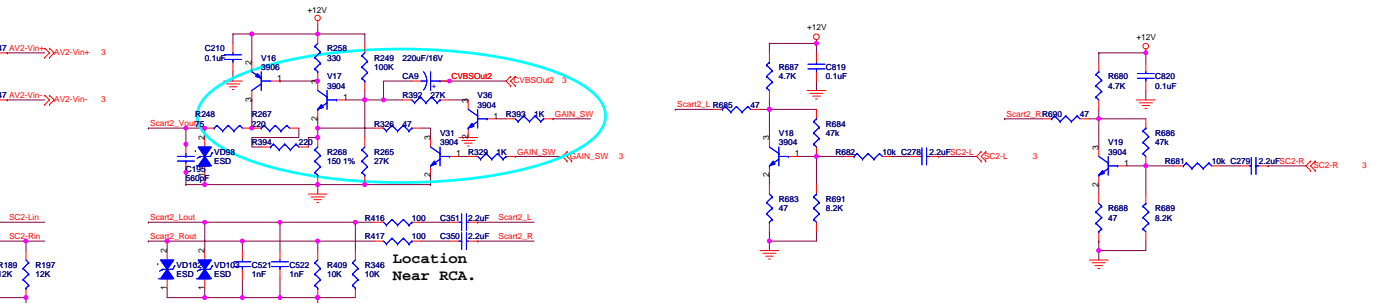
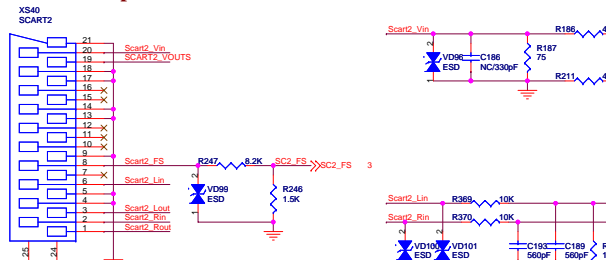

5V and 12V for Tuner

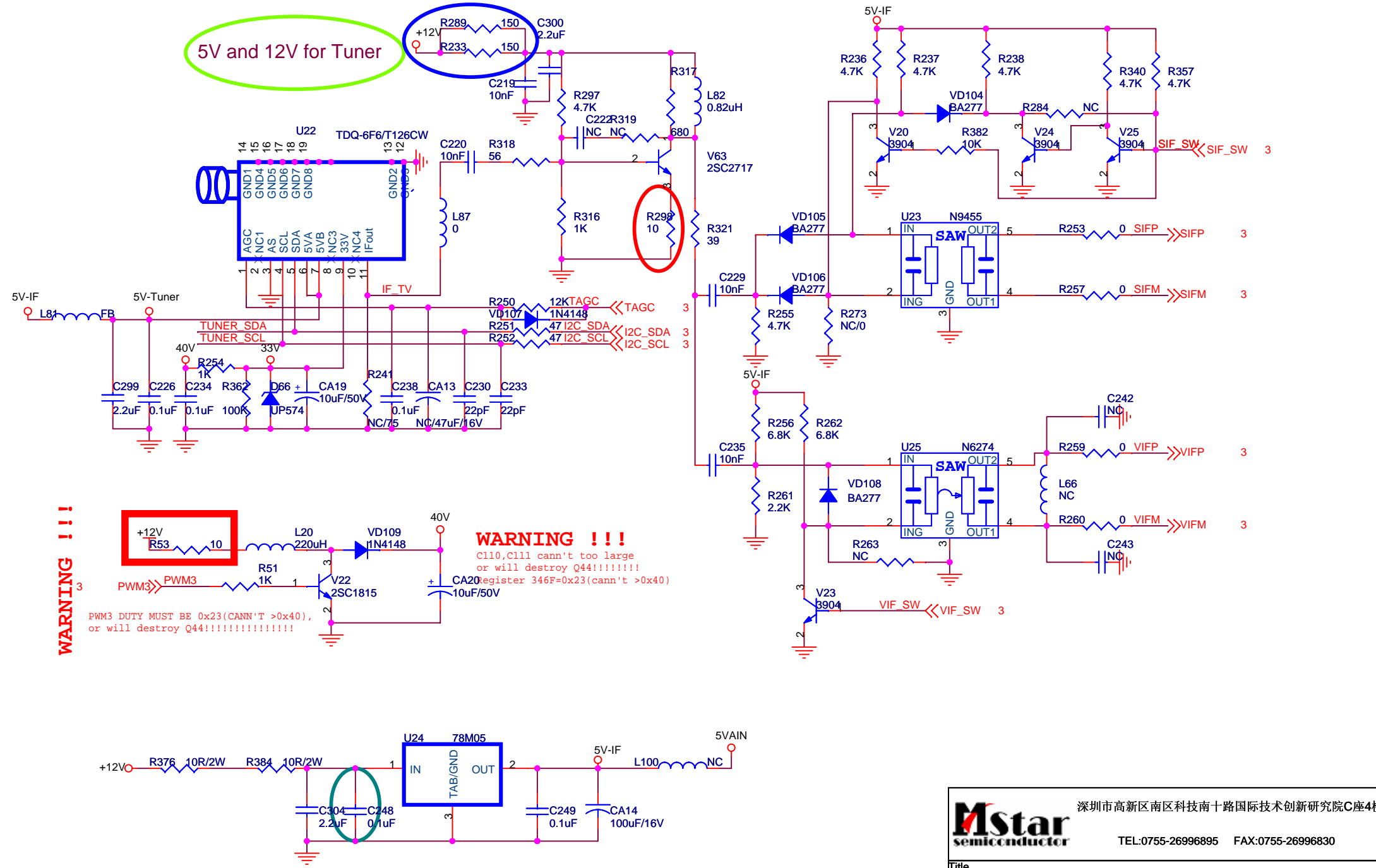

WARNING !!!

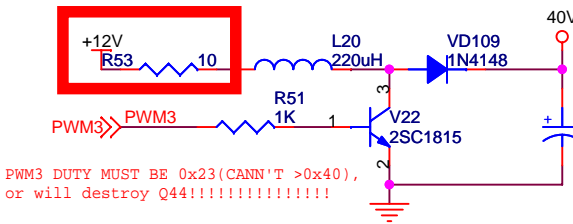

WARNING !!!
 C110, C111 cann't too large
 or will destroy Q44!!!!!!!
 register 346F=0x23(cann't >0x40)

PWM3 DUTY MUST BE 0x23(CANN'T >0x40),
 or will destroy Q44!!!!!!!!!!!!!!!

		深圳市高新区南区科技南十路国际技术创新研究院C座4楼 TEL:0755-26996895 FAX:0755-26996830	
Title: TUNER			
Size: A4	Document Number: MST6M16		Rev: 01A
Date: Friday, April 10, 2009	Sheet: 8		of 10

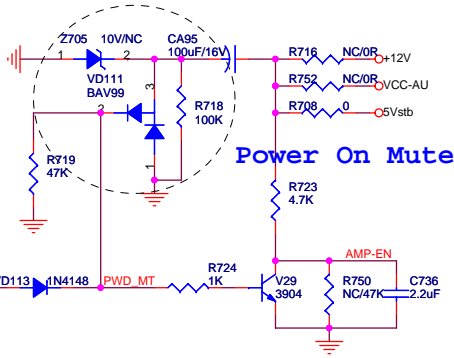
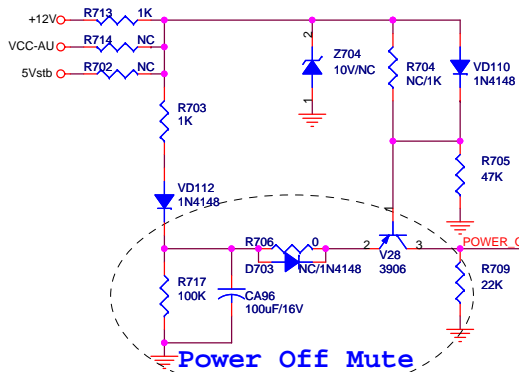

LOW: shut down
HIGH: OPERATING
HIGH: MUTE
LOW: OPERATING

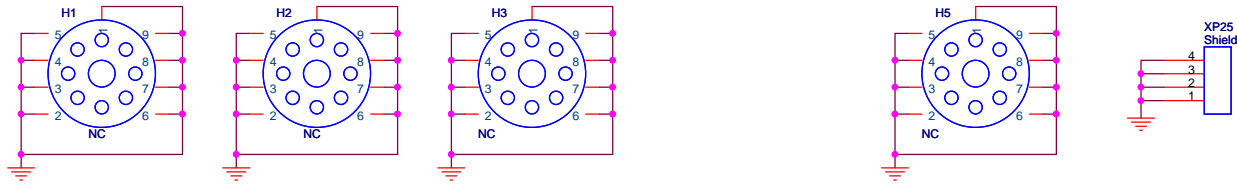
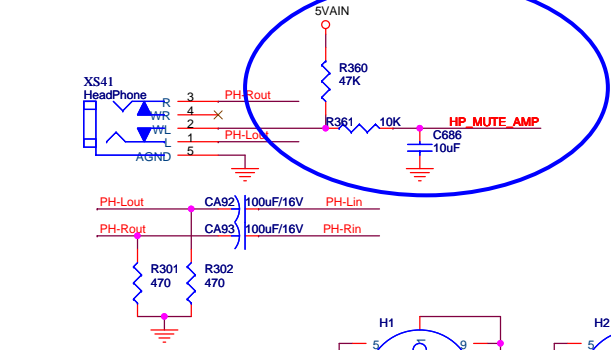
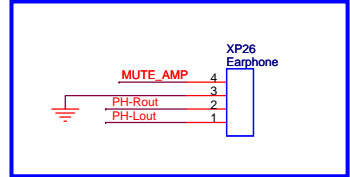
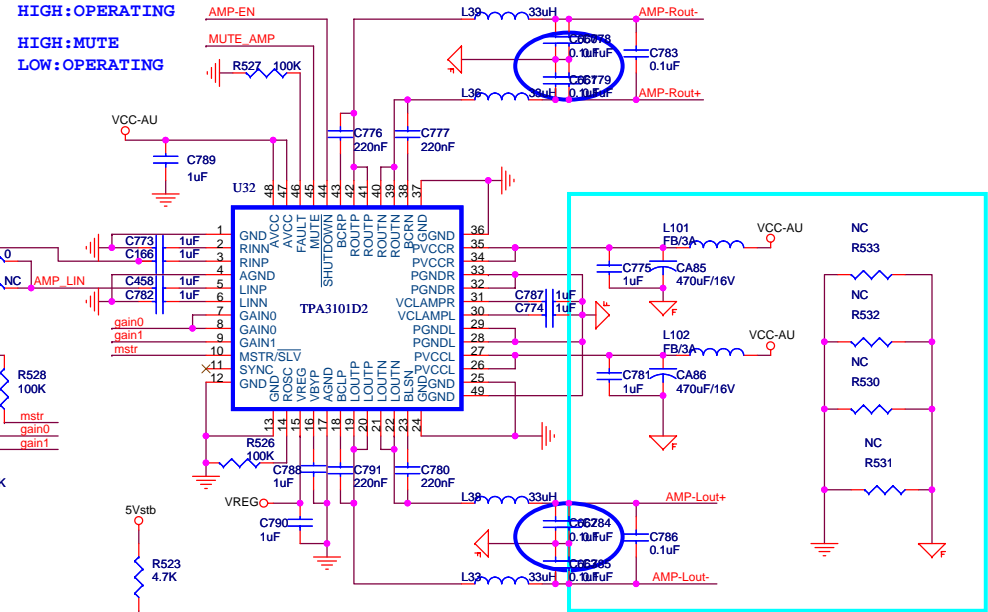
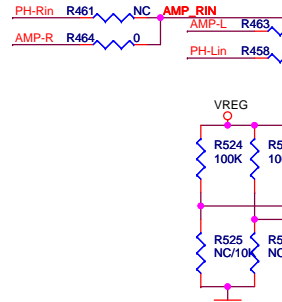
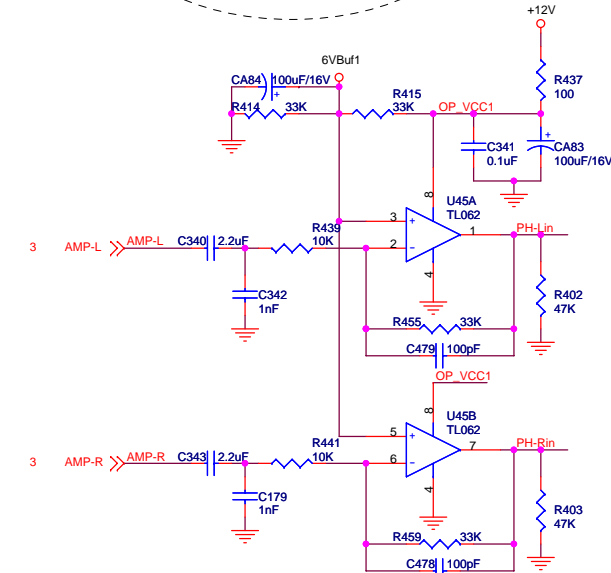

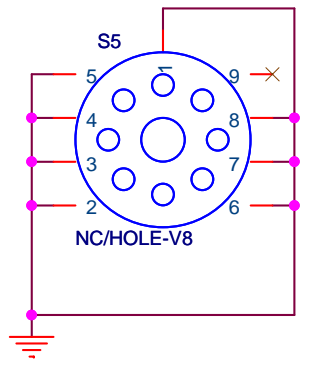
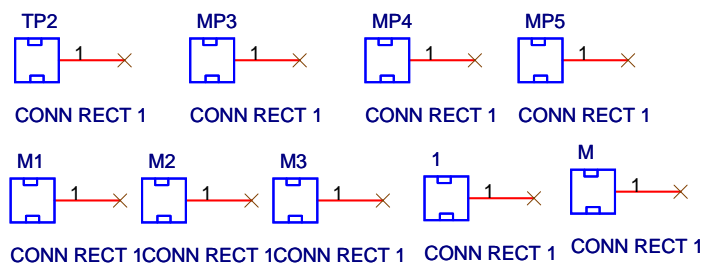
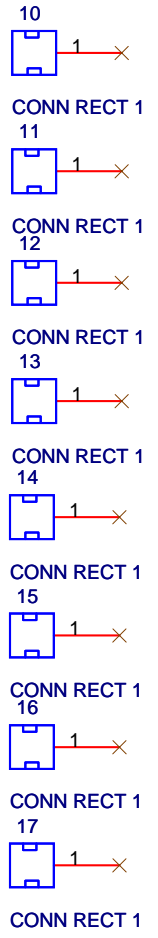
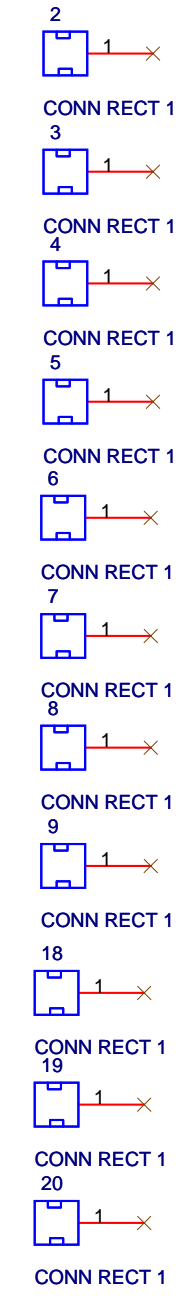
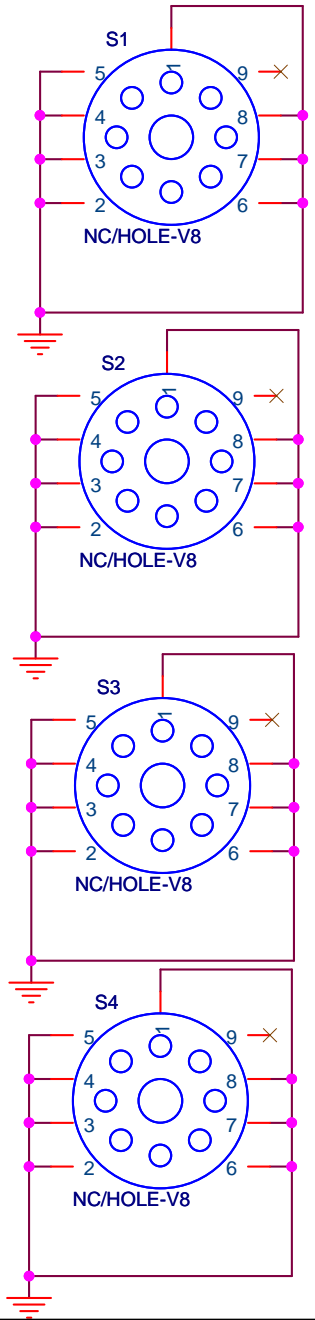
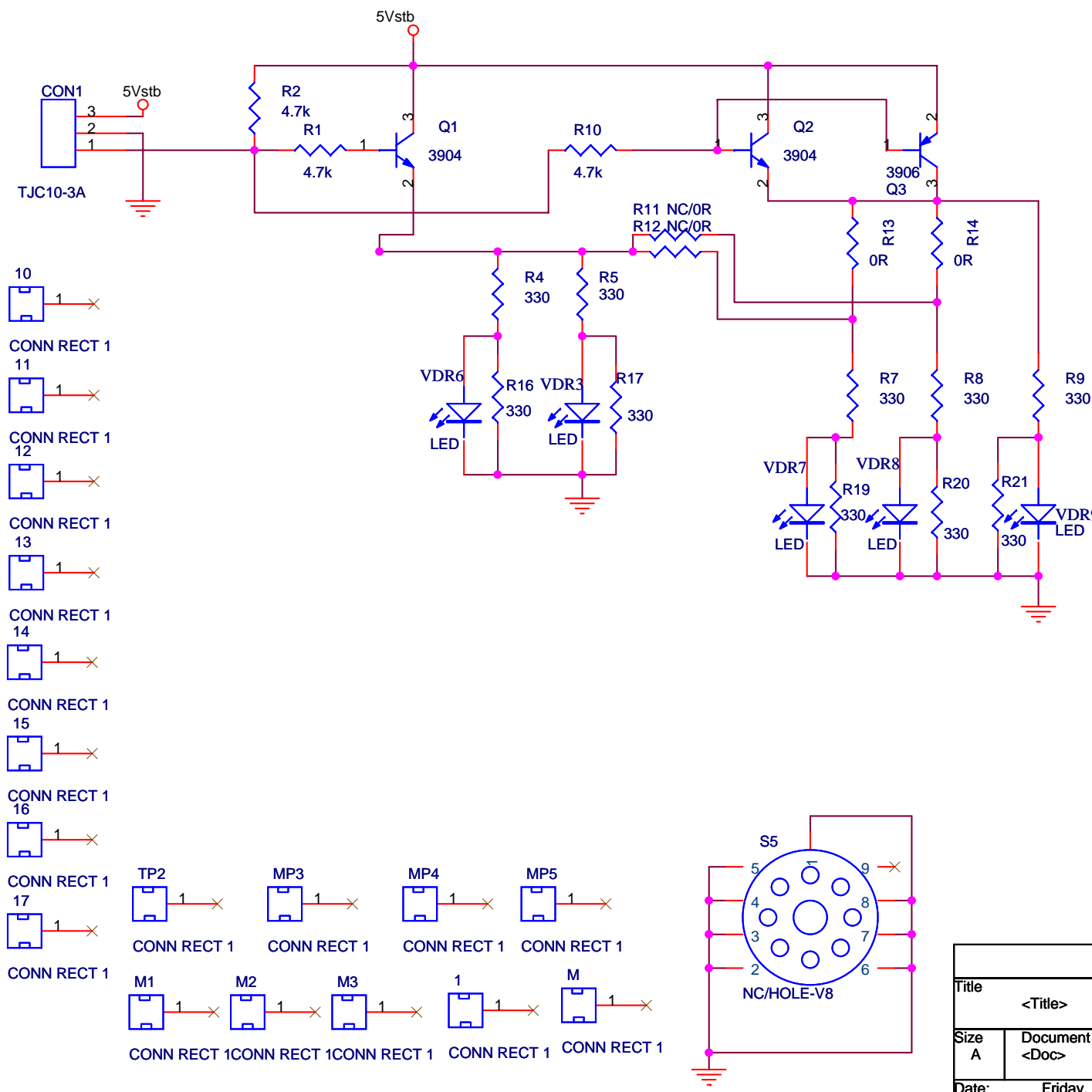

Title <Title>		
Size A	Document Number <Doc>	Rev <RevCode>
Date:	Friday, February 27, 2009	Sheet 1 of 1

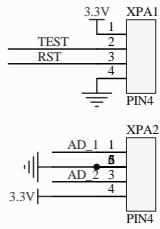

接口部分：
 1、XPA2、XPA3接口为2.0间距卧式直插插座；
 2、XPA1为调试接口，留出焊盘，方便调试；
 3、I2C接口也为后期调试接口，最好有；如果影响PCB布局，可以不要，上面的两个电阻也可一并省去；

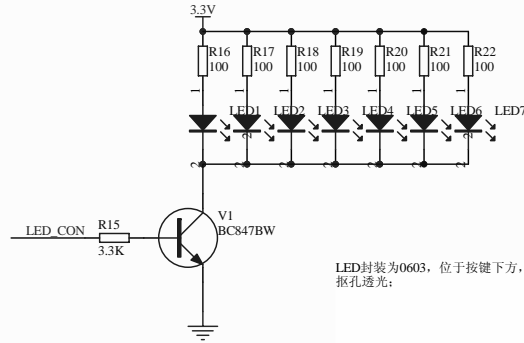

LED封装为0603，位于按键下方，
 板孔透光；

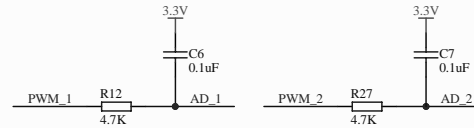
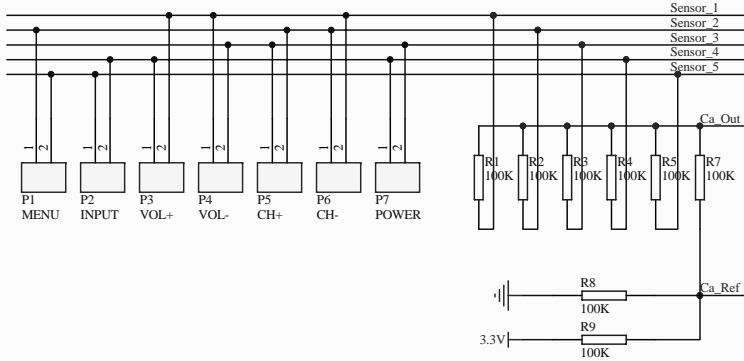
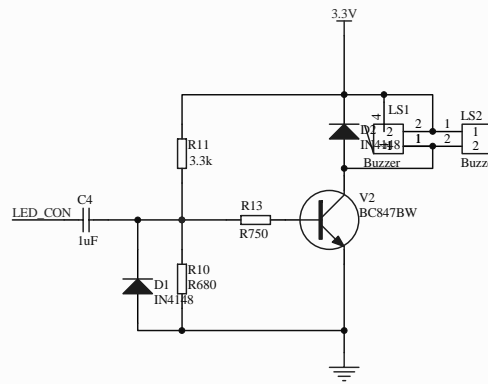
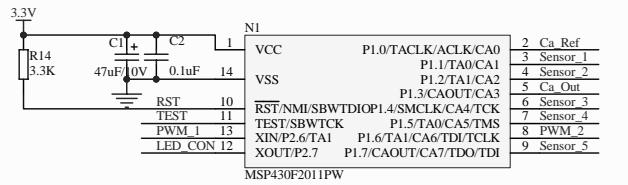
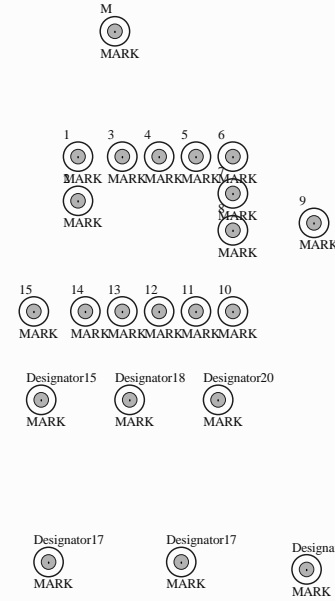

Title		
Size B	Number	Revision
Date: 2009-6-18	Sheet of	
File: E:\LCD\...\LHD26V88US_KEY_B(1833).SCH	CHENBY	

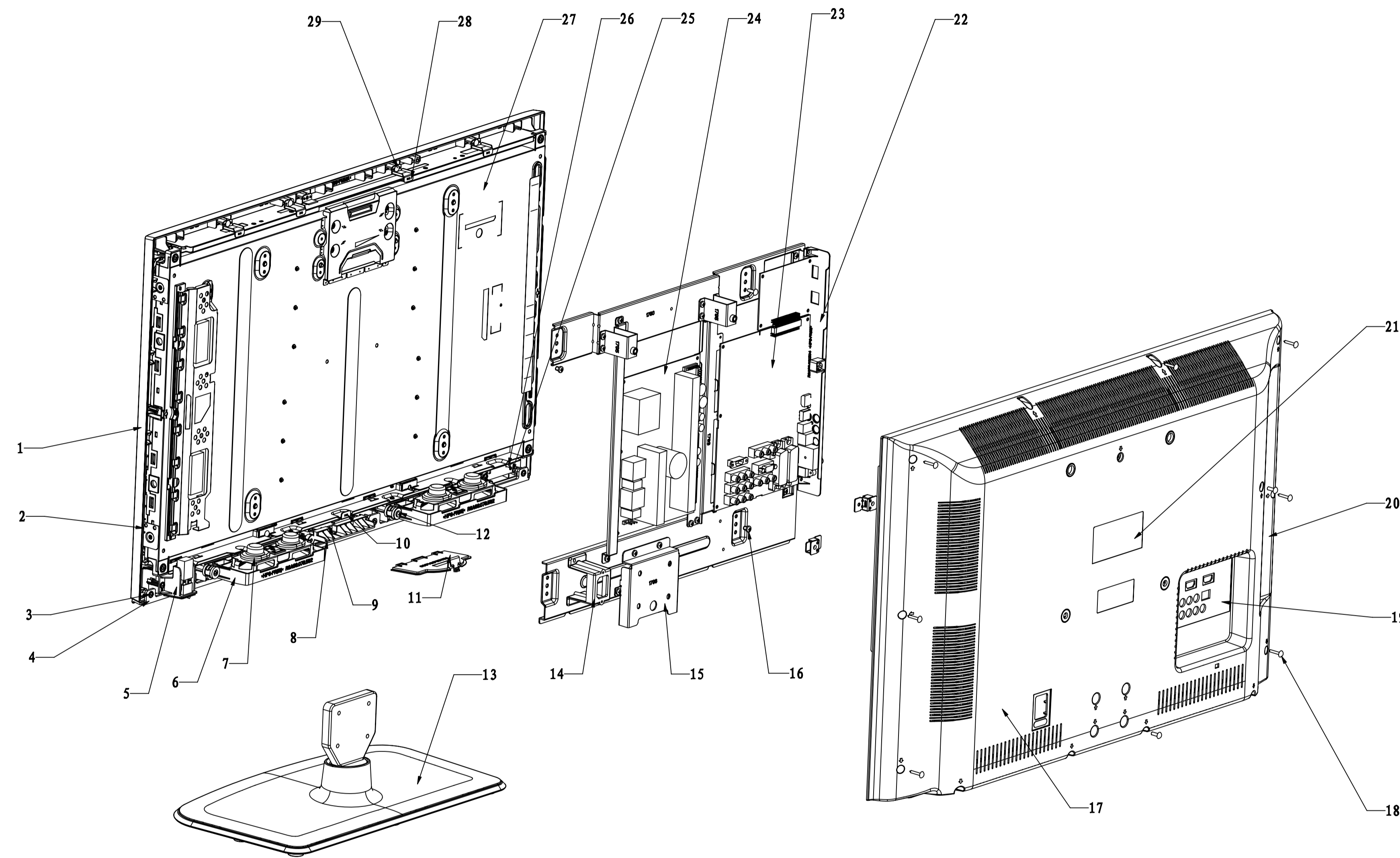

29	SCREW	7	SJ2824-87 ST4X10F镀锌银白
28	BRACKET	4	RSAG8.038.1845
27	LCD PANEL	1	LTA320AP02\JK
26	LENS LED	1	RSAG8.640.077
25	IR BOARD UNIT	1	RSAG2.908.1566-3
24	MAIN BOARD UNIT	1	RSAG2.908.1525-1
23	POWER BOARD UNIT	1	RSAG2.908.1285
22	TERMINAL BRACKET	1	RSAG8.081.516
21	RATING LABEL	1	
20	SCUTCHEON	1	RSAG8.804.3456
19	SCUTCHEON	1	RSAG8.804.3455
18	SCREW	8	SJ2824-87 ST4X20C黑色
17	BACK COVER	1	RSAG8.074.700
16	SCREW	10	GB/T 818-2000 M4X6镀锌银白
15	BRACKET UNIT	1	RSAG4.114.099
14	BRACKET	1	RSAG8.078.514
13	BASE UNIT	1	WG6.121.082
12	SCREW	4	SJ2838-87 ST4X12F. II镀锌银白
11	COVER BOARD	1	RSAG8.634.090
10	BRACKET	1	RSAG8.038.1493
9	RSAG2.908.1534-2	1	RSAG2.908.1534-2
8	BRACKET	1	RSAG8.078.593
7	SPEAKER	2	YDT4215NE-10W8R-B
6	BRACKET	1	RSAG8.078.592
5	SWITCH BRACKET	1	RSAG8.078.591
4	ornament bracket	1	RSAG8.647.312
3	SCREW	16	SJ2825-87 ST3X12C
2	KEY BOARD UNITS	1	RSAG2.908.1625-4
1	FRONT CABINET	1	RSAG8.074.658
NO.	NAME.	NO.	CODE.

LCD32V88AM

旧底图总号

底图总号

签名

格式(1)

A1