



December 1998

**8 - Bit Micro-controller***with 64KB flash embedded***Product List**

MSU2964C16, 16 MHz 64 KB internal memory MCU  
 MSU2964C25, 25 MHz 64 KB internal memory MCU  
 MSU2964C40, 40 MHz 64 KB internal memory MCU

**Description**

The MVI MSU2964 series product is an 8 - bit single chip microcontroller with 64 KB flash embedded. It provides hardware features and a powerful instruction set, necessary to make it a versatile and cost effective controller for those applications demand up to 32 I/O pins or need up to 64 K byte memory either for program or for data or mixed.

To program the flash block, a commercial programmer is capable to do it.

**Ordering Information**

MSU2964ihhk (blank chip)  
 MSU2964ihh - yyyk

i: process identifier {L, C}.

hh: working clock in MHz {16, 25, 40}.

yyy: production code {001, ..., 999}

k: package type postfix {as below table}.

Postfix	Package	Pin/Pad Configuration	Dimension	Logo Size at Top Marking
blank	dice	page 7	page 13	-
P	40L PDIP	page 2	page 11	5.0 x 4.2 mm
J	44L PLCC	page 2	page 12	4.5 x 3.8 mm
Q	44L PQFP	page 2	-	2.8 x 2.4 mm
U	44L LQFP	page 2	-	2.8 x 2.4 mm

**Features**

- Working voltage : 4.5 V through 5.5 V
- Programming voltage : 5 V
- General 80C51 family compatible
- 12 clocks per machine cycle
- 64 K byte internal flash memory
- 256 byte data RAM
- Three 16 bit Timers/Counters
- Four 8-bit I/O ports
- Full duplex serial channel
- Bit operation instructions
- Page free jumps
- 8 - bit Unsigned Division
- 8 - bit Unsigned Multiply
- BCD arithmetic
- Direct Addressing
- Indirect Addressing
- Nested Interrupt
- Two priority level interrupt
- A serial I/O port
- Power save modes:
  - Idle mode and Power down mode
- Working at 16/25/40 MHz Clock



### Pin Configurations

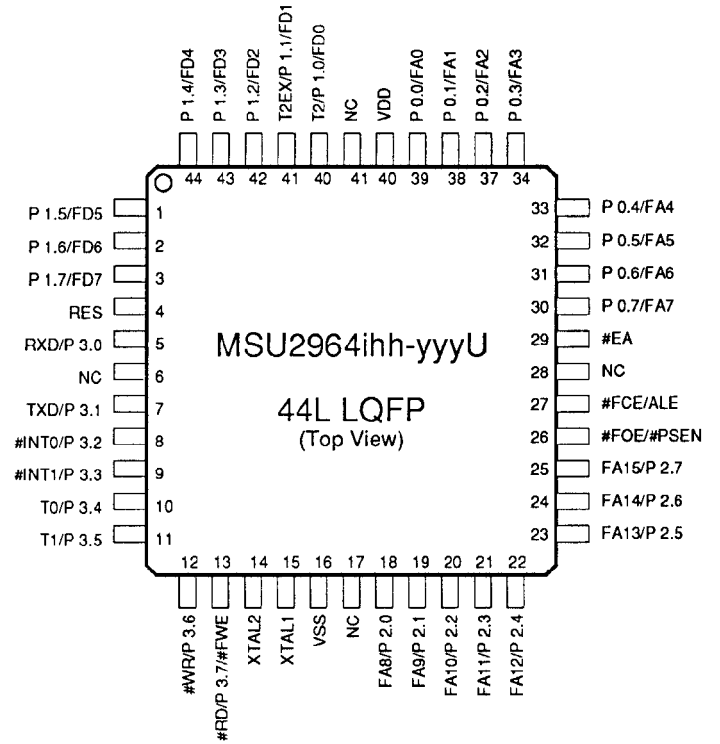
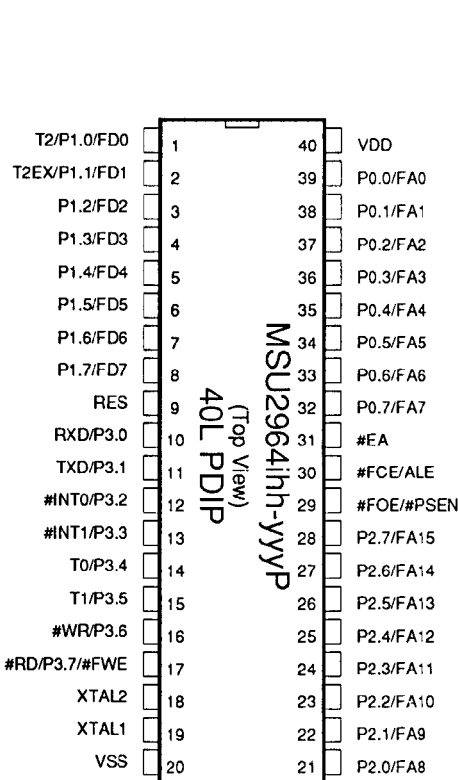
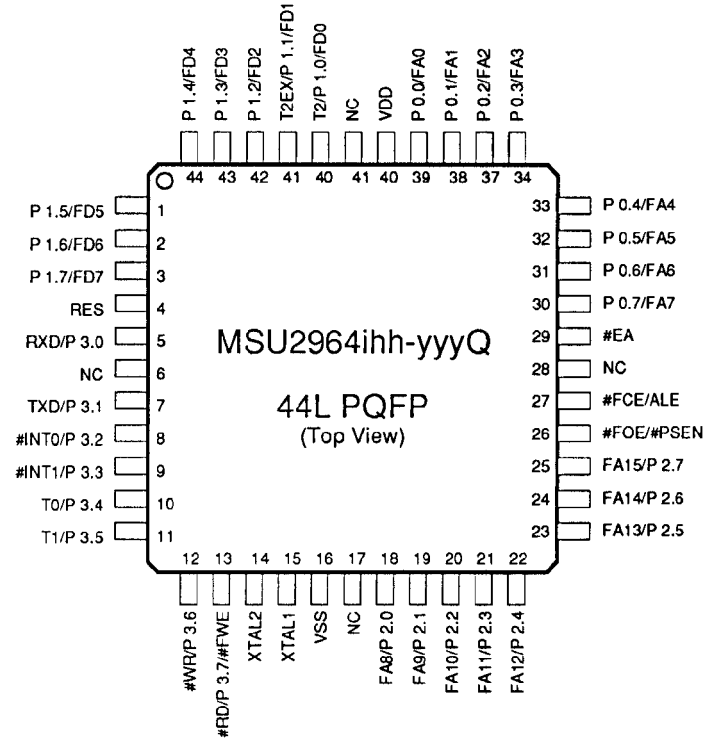
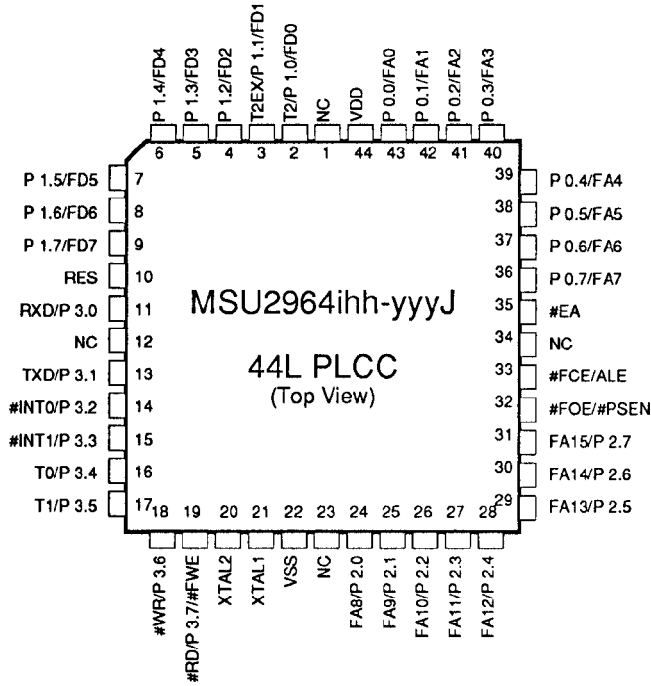

Specifications subject to change without notice, contact your sales representatives for the most recent information.



### Block Diagram

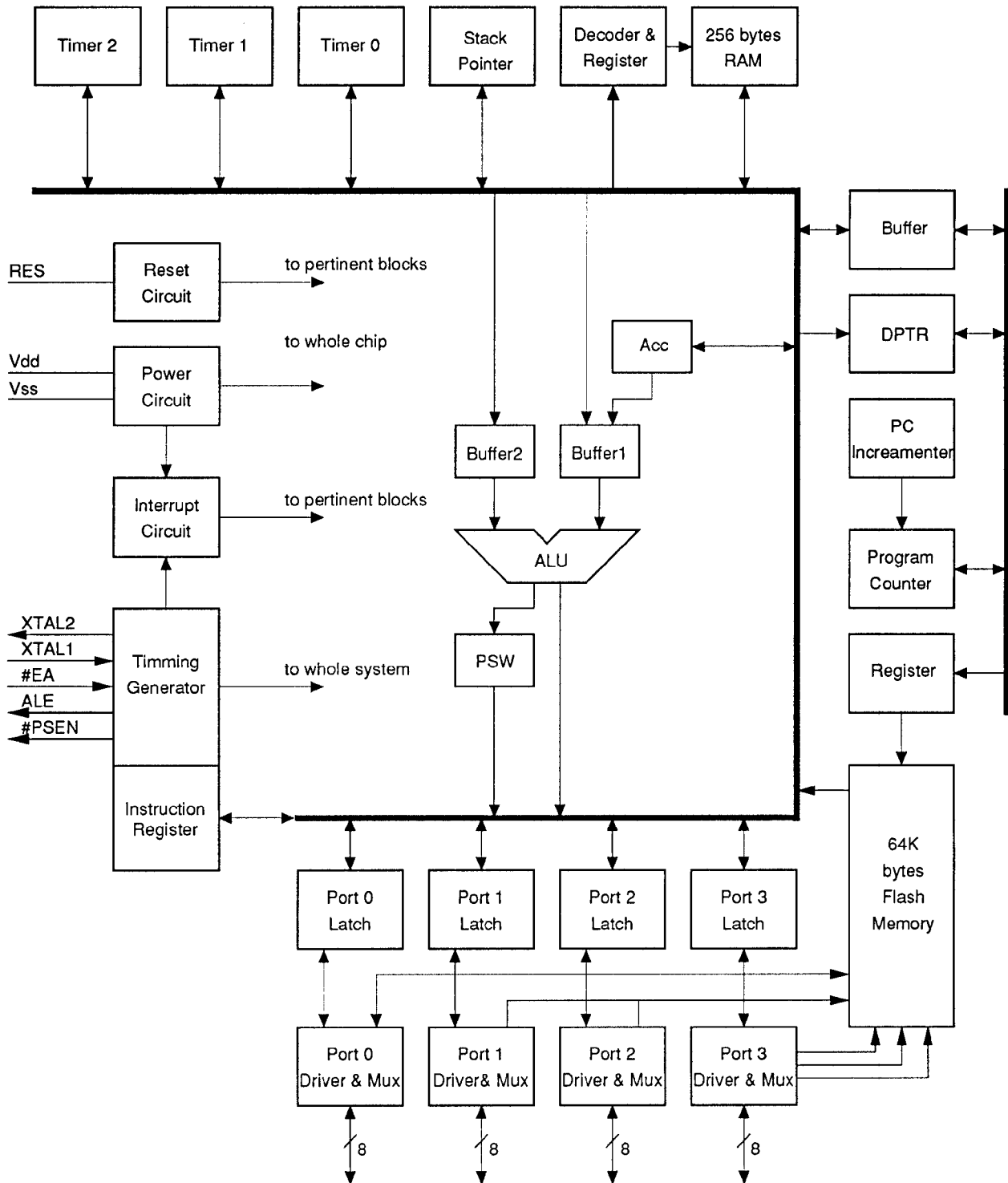

Specifications subject to change without notice, contact your sales representatives for the most recent information.



## Pin Descriptions

40L PDIP Pin#	44L LQFP Pin#	44L PQFP Pin#	44L PLCC Pin#	Symbol	Active	I/O	Names
1	40	40	2	T2/P1.0/FD0		i/o	bit 0 of Port 1 & timer 2 & bit 0 of flash block address
2	41	41	3	T2EX/P1.1/FD1		i/o	bit 1 of Port 1 & timer control & bit 1 of flash block addr.
3	42	42	4	P1.2/FD2		i/o	bit 2 of Port 1 & bit 2 of flash block address
4	43	43	5	P1.3/FD2		i/o	bit 3 of Port 1 & bit 3 of flash block address
5	44	44	6	P1.4/FD4		i/o	bit 4 of Port 1 & bit 4 of flash block address
6	1	1	7	P1.5/FD5		i/o	bit 5 of Port 1 & bit 5 of flash block address
7	2	2	8	P1.6/FD6		i/o	bit 6 of Port 1 & bit 6 of flash block address
8	3	3	9	P1.7/FD7		i/o	bit 7 of Port 1 & bit 7 of flash block address
9	4	4	10	RES	H	i	Reset
10	5	5	11	RXD/P3.0		i/o	bit 0 of Port 3 & Receive data & flash block enable
11	7	7	13	TXD/P3.1		i/o	bit 1 of Port 3 & Transmit data
12	8	8	14	#INT0/P3.2	L -	i/o	bit 2 of Port 3 & low true Interrupt 0
13	9	9	15	#INT1/P3.3	L -	i/o	bit 3 of Port 3 & low true Interrupt 1
14	10	10	16	T0/P3.4		i/o	bit 4 of Port 3 & Timer 0
15	11	11	17	T1/P3.5		i/o	bit 5 of Port 3 & Timer 1
16	12	12	18	#WR/P3.6	L -	i/o	bit 6 of Port 3 & o/p enable to flash block (low enable)
17	13	13	19	#RD/P3.7/#FWE	L - /L	i/o	bit 7 of Port 3 & write enable to flash block (low enable)
18	14	14	20	XTAL2		o	Crystal out
19	15	15	21	XTAL1		i	Crystal in
20	16	16	22	VSS			Sink Voltage, Ground
21	18	18	24	P2.0/FA8		i/o	bit 0 of Port 2 & bit 8 of flash block address
22	19	19	25	P2.1/FA9		i/o	bit 1 of Port 2 & bit 9 of flash block address
23	20	20	26	P2.2/FA10		i/o	bit 2 of Port 2 & bit 10 of flash block address
24	21	21	27	P2.3/FA11		i/o	bit 3 of Port 2 & bit 11 of flash block address
25	22	22	28	P2.4/FA12		i/o	bit 4 of Port 2 & bit 12 of flash block address
26	23	23	29	P2.5/FA13		i/o	bit 5 of Port 2 & bit 13 of flash block address
27	24	24	30	P2.6/FA14		i/o	bit 6 of Port 2 & bit 14 of flash block address
28	25	25	31	P2.7/FA15		i/o	bit 7 of Port 2 & bit 15 of flash block address
29	26	26	32	#PSEN/#FOE	L/L	o/i	program storage enable
30	27	27	33	ALE/#FCE	- /L	o/i	address latch enable
31	29	29	35	#EA	L	i	external access
32	30	30	36	P0.7/FA7		i/o	bit 7 of Port 0 & data bit 7 of flash block
33	31	31	37	P0.6/FA6		i/o	bit 6 of Port 0 & data bit 6 of flash block
34	32	32	38	P0.5/FA5		i/o	bit 5 of Port 0 & data bit 5 of flash block
35	33	33	39	P0.4/FA4		i/o	bit 4 of Port 0 & data bit 4 of flash block
36	34	34	40	P0.3/FA3		i/o	bit 3 of Port 0 & data bit 3 of flash block
37	35	35	41	P0.2/FA2		i/o	bit 2 of Port 0 & data bit 2 of flash block
38	36	36	42	P0.1/FA1		i/o	bit 1 of Port 0 & data bit 1 of flash block
39	37	37	43	P0.0/FA0		i/o	bit 0 of Port 0 & data bit 0 of flash block
40	38	38	44	VDD			Drive Voltage, +5 Vcc

Specifications subject to change without notice, contact your sales representatives for the most recent information.



### Operating Conditions

Symbol	Description	Min.	Typ.	Max.	Unit	Remarks
t <sub>A</sub>	Ambient temperature under bias	0	25	70	°C	
V <sub>CC5</sub>	Supply voltage	4.5	5.0	5.5	V	U2964C
f <sub>osc 16</sub>	Oscillator Frequency	3.0	16	16	MHz	U2964C16
f <sub>osc 25</sub>		16	25	25	MHz	U2964C25
f <sub>osc 40</sub>		25	40	40	MHz	U2964C40

### AC Characteristics

(16/25/40 MHz, operating conditions; CL for Port 0, ALE and PSEN Outputs=150pF; CL for all Other Outputs=80pF)

Symbol	Parameter	Valid Cycle	f <sub>osc 16</sub>			Variable f <sub>osc</sub>			Unit	Remarks
			Min.	Typ.	Max	Min.	Typ.	Max.		
T <sub>LHLL</sub>	ALE pulse width	RD/WRT	115			2xT - 10			nS	
T <sub>AVLL</sub>	Address Valid to ALE low	RD/WRT	43			T - 20			nS	
T <sub>LLAX</sub>	Address Hold after ALE low	RD/WRT	53			T-10			nS	
T <sub>LLIV</sub>	ALE low to Valid Instruction In	RD			240			4xT - 10	nS	
T <sub>LLPL</sub>	ALE low to #PSEN low	RD	53			T-10			nS	
T <sub>PLPH</sub>	#PSEN pulse width	RD	173			3xT - 15			nS	
T <sub>PLIV</sub>	#PSEN low to Valid Instruction In	RD			177			3xT - 10	nS	
T <sub>PXIX</sub>	Instruction Hold after #PSEN	RD	0			0			nS	
T <sub>PXIZ</sub>	Instruction Float after #PSEN	RD			87			T + 25	nS	
T <sub>AVIV</sub>	Address to Valid Instruction In	RD			292			5xT - 20	nS	
T <sub>PLAZ</sub>	#PSEN low to Address Float	RD			10			10	nS	
T <sub>RLRH</sub>	#RD pulse width	RD	365			6xT - 10			nS	
T <sub>WLWH</sub>	#WR pulse width	WRT	365			6xT - 10			nS	
T <sub>RLDV</sub>	#RD low to Valid Data in	RD			302			5xT - 10	nS	
T <sub>RHDX</sub>	Data Hold after #RD	RD	0			0			nS	
T <sub>RHDZ</sub>	Data Float after #RD	RD			145			2xT + 20	nS	
T <sub>LLDV</sub>	ALE low to Valid Data In	RD			590			8xT - 10	nS	
T <sub>AVDV</sub>	Address to Valid Data In	RD			542			9xT - 20	nS	
T <sub>LLYL</sub>	ALE low to #WR or #RD low	RD/WRT	178		197	3xT - 10		3xT + 10	nS	
T <sub>AVYL</sub>	Address Valid to #WR or #RD low	RD/WRT	230			4xT - 20			nS	
T <sub>QVWH</sub>	Data Valid to #WR High	WRT	403			7xT - 35			nS	
T <sub>QVWX</sub>	Data Valid to #WR transition	WRT	38			T - 25			nS	
T <sub>WHQX</sub>	Data hold after #WR	WRT	73			T + 10			nS	
T <sub>RLAZ</sub>	#RD low to Address Float	RD						5	nS	
T <sub>YHLH</sub>	#WR or #RD high to ALE high	RD/WRT	53		72	T - 10		T + 10	nS	
T <sub>CHCL</sub>	Clock fall time								nS	
T <sub>CLCX</sub>	Clock low time								nS	
T <sub>CLCH</sub>	Clock rise time								nS	
T <sub>CHCX</sub>	Clock high time								nS	
T, T <sub>CLCL</sub>	Clock period			63			1/ fosc		nS	

Specifications subject to change without notice, contact your sales representatives for the most recent information.



### DC Characteristics

(16/25/40 MHz, typical operating conditions, valid for U2964C series)

Symbol	Parameter	Valid	Min.	Typ.	Max	Unit	Test Conditions
V ILX	Input Low Voltage	XTAL1	-0.5		20%V <sub>cc</sub> -0.1	V	
		#EA	0		20%V <sub>cc</sub> -0.3	V	
V ILR	"	RES	-0.5		20%V <sub>cc</sub> -0.1	V	
V IHX	Input High Voltage	XTAL1	70%V <sub>cc</sub>		V <sub>cc</sub> +0.5	V	
		#EA	20%V <sub>cc</sub> + 0.9		V <sub>cc</sub> +0.5	V	
V IHR	"	RES	70%V <sub>cc</sub>		V <sub>cc</sub> +0.5	V	
	Output Low Voltage	ALE, #PSEN			450	mV	I <sub>OL</sub> = 3.2 mA
V OL0	"	ports 0,3			450	mV	I <sub>OL</sub> = 3.2 mA
V OL1	"	ports 1,2			450	mV	I <sub>OL</sub> = 1.6 mA
	Output High Voltage	ALE, #PSEN	2.4			V	I <sub>OH</sub> = -60 uA
	"		90%V <sub>cc</sub>			V	I <sub>OH</sub> = -10 uA
V OH0	"	port 0	2.4			V	I <sub>OH</sub> = -800 uA
	"		90%V <sub>cc</sub>			V	I <sub>OH</sub> = -80 uA
V OH1	"	ports 1,3	2.4			V	I <sub>OH</sub> = -60 uA
	"		90%V <sub>cc</sub>			V	I <sub>OH</sub> = -10 uA
V OH2	"	port 2	2.4			V	I <sub>OH</sub> = -60 uA
	"		90%V <sub>cc</sub>			V	I <sub>OH</sub> = -10 uA
I OL0	Output Low Current	ports 0,3				mA	V <sub>OL</sub> = 0.45V, note 1
I IL	Logical 0 Input Current	ports 1,2,3			50	uA	V <sub>in</sub> = 0.45 V
I IH	Logical 1 Input Current	port 0			1.5	uA	V <sub>in</sub> = 5.0 V
I TL	Logic Transition Current	ports 1,2,3			650	uA	V <sub>in</sub> = 2.0 V
I LI	Input Leakage Current	port 0			10	uA	0.45V < V <sub>in</sub> < V <sub>cc</sub>
R RES	Reset Pulldown Resistance	RES	50		150	Kohm	
R X	Crystal feedback Resistance	XTAL1,2	90		330	Kohm	
C IO	Pin Capacitance				10	pF	Freq=1MHz, Ta=25 °C
I CC	Power Supply Current	V <sub>dd</sub>			8	mA	Active mode, 16 MHz
		V <sub>dd</sub>			25	mA	Idle mode, 16MHz
		V <sub>dd</sub>			25	mA	Power down mode

note 1 : no more than 80 mA I<sub>OL</sub>s for all 16-bit ports 0 & 3 output pins.

### To Program

The program mean is identical to MVI's flash V29C51002 except the memory size. This MSU2964 has 512 K bit (64 K x 8) while the V29C51002 has 2 mega bit (256 K x 8). Of course, the pin configuration is not identical. MVI provides an adapter board M9015 to transform those pins to fit into pins of commercial 2-mega-bit flash which is organized in 8-bit width.



### Data Memory Read Cycle Timing

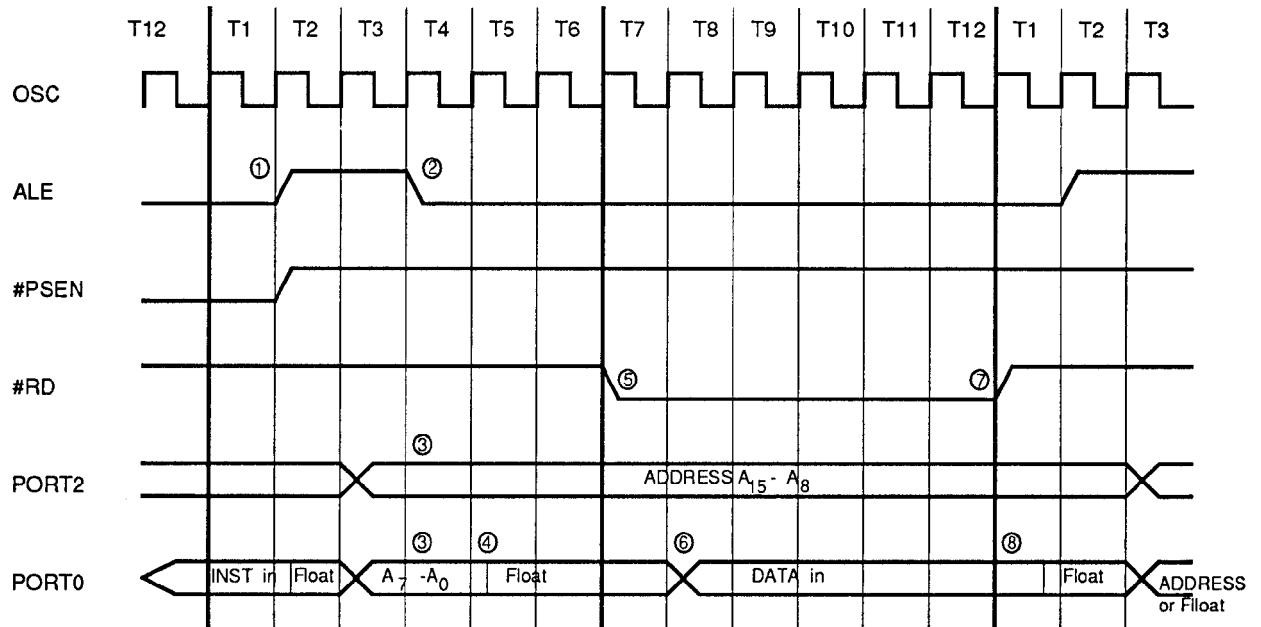

### Program Memory Read Cycle Timing

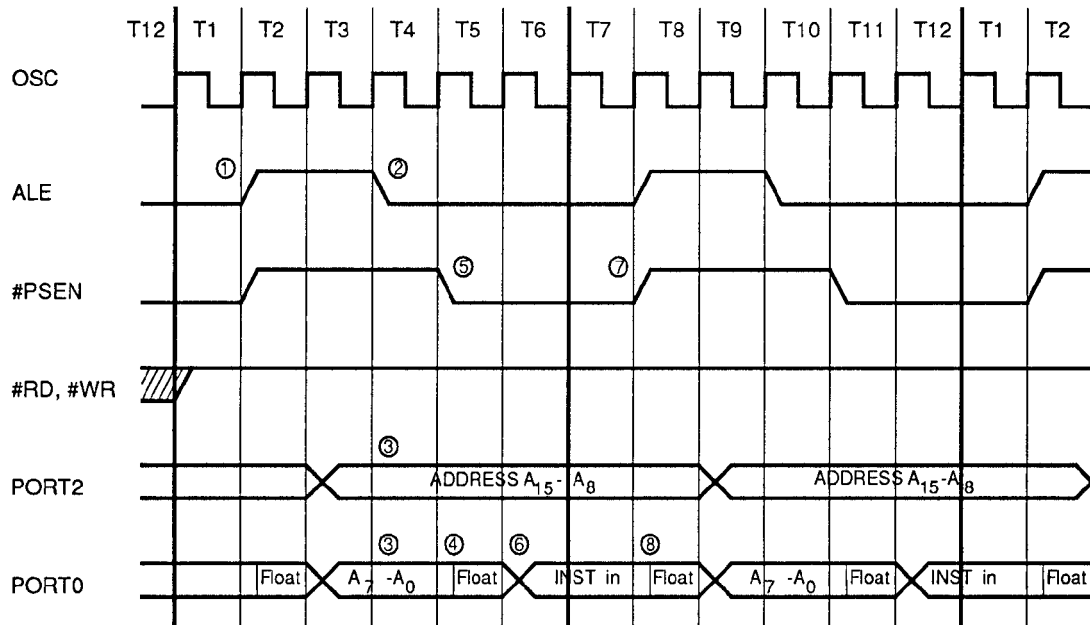

Specifications subject to change without notice, contact your sales representatives for the most recent information.



### Data Memory Write Cycle Timing

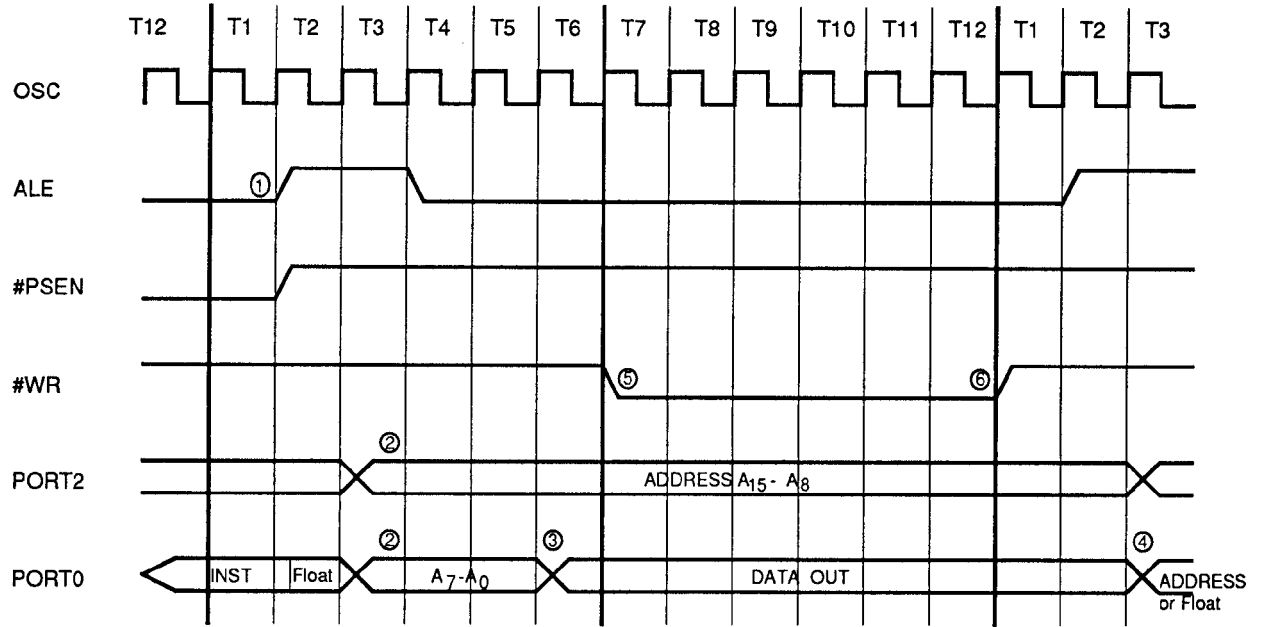

### I/O Ports Timing

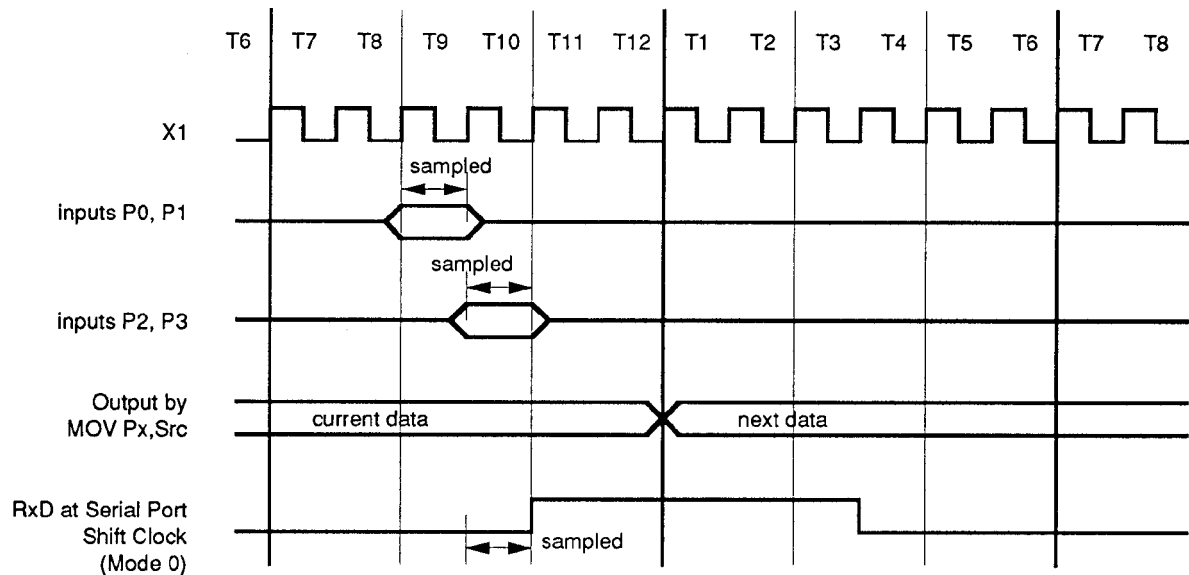

Specifications subject to change without notice, contact your sales representatives for the most recent information.





Timing Critical, Requirement of External Clock (V<sub>ss</sub>=0.0V is assumed)

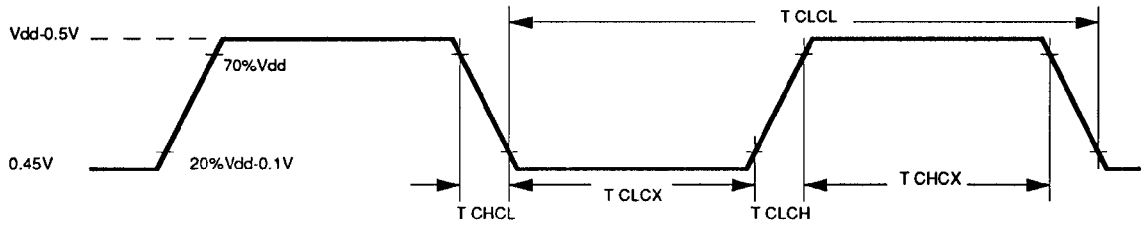

Tm.I External Program Memory Read Cycle

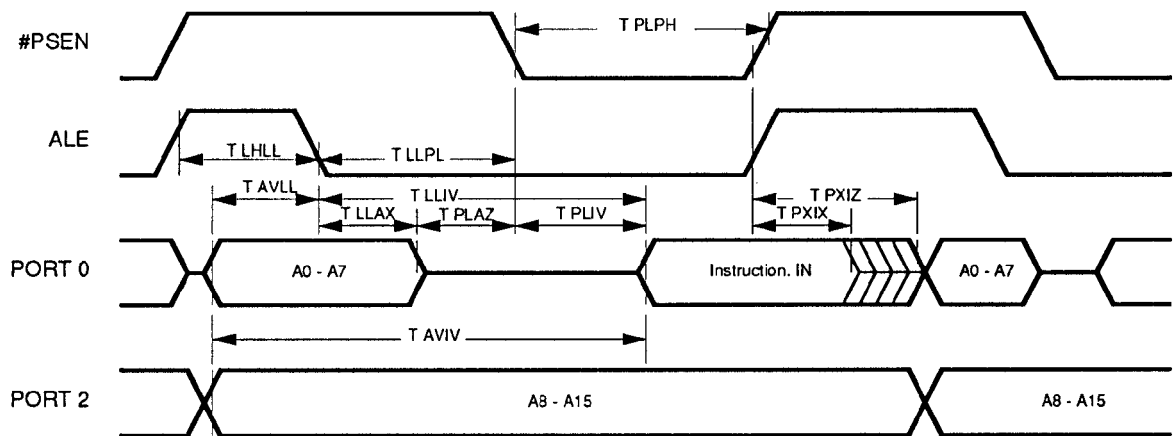

Tm.II External Data Memory Read Cycle

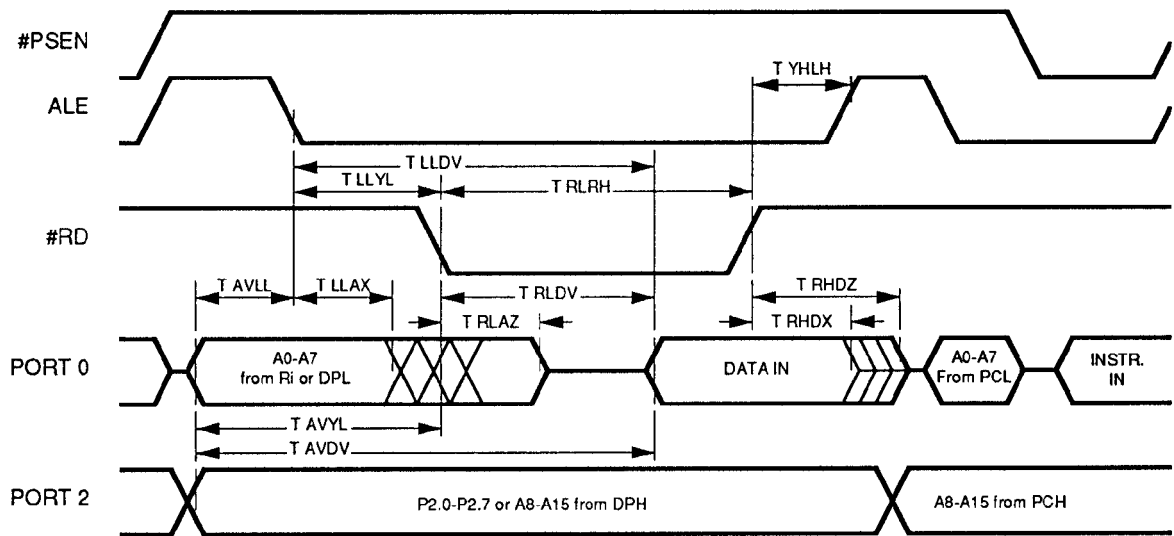

Specifications subject to change without notice, contact your sales representatives for the most recent information.



**Tm.III External Data Memory Write Cycle**

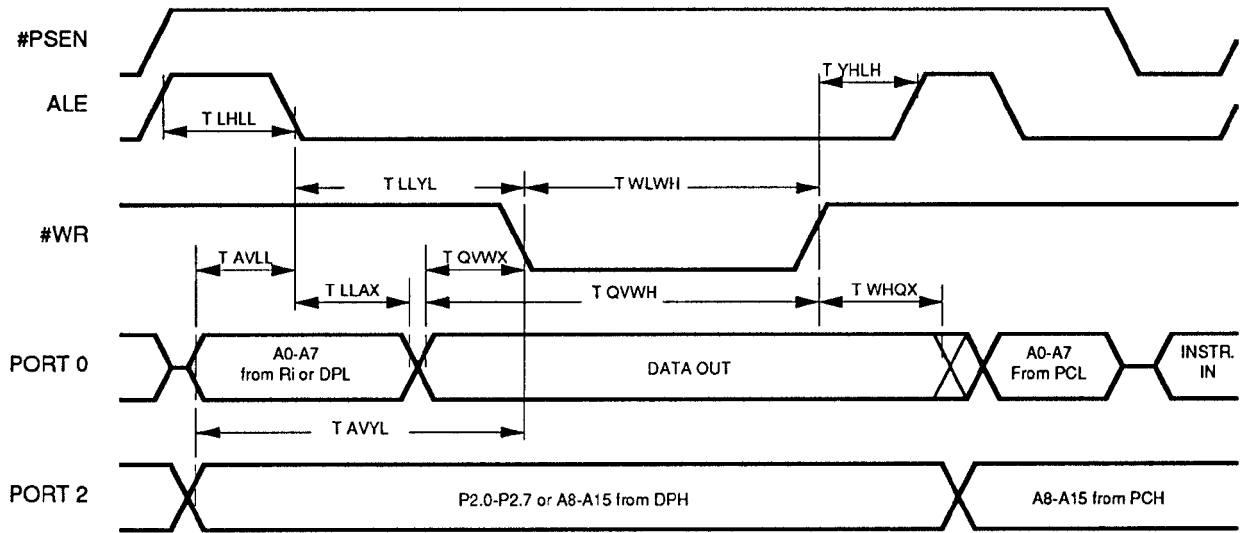

**Application Reference**

Valid for U2964C				
X'tal	3 MHz	6 MHz	9 MHz	12 MHz
C1				
C2				
R	open	open	open	open
X'tal	16 MHz	25 MHz	33 MHz	40 MHz
C1	30 pF	15 pF		5 pF
C2	30 pF	15 pF		5 pF
R	open	62 Kohm		4.7 Kohm

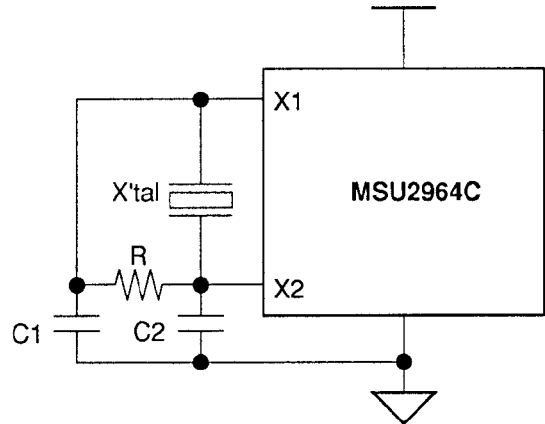

Specifications subject to change without notice, contact your sales representatives for the most recent information.



40L 600mil PDIP Information

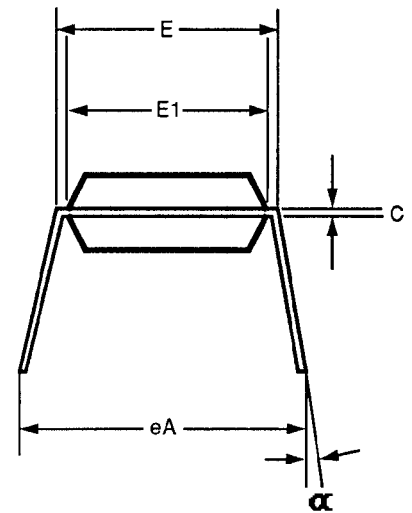
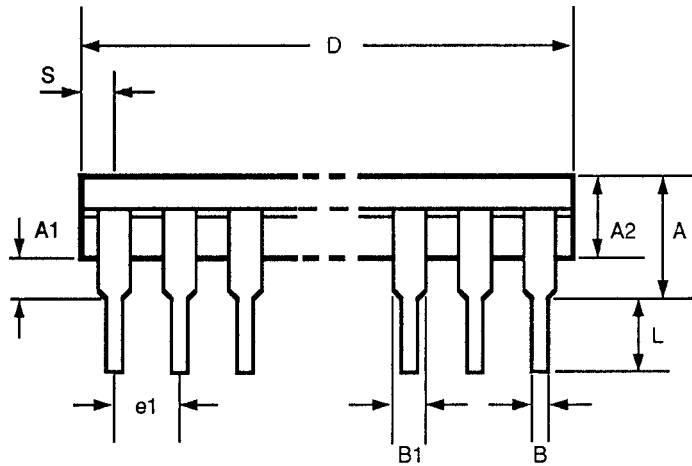

Note:

- 1.Dimension D Max & S include mold flash or tie bar burrs.
- 2.Dimension E1 does not include interlead flash.
- 3.Dimension D & E1 include mold mismatch and are determined at the mold parting line.
- 4.Dimension B1 does not include dambar protrusion/infusion.
- 5.Controlling dimension is inch.
- 6.General appearance spec. should base on final visual inspection spec.

Symbol	Dimension in Inch	Dimension in mm
	minimal/maximal	minimal/maximal
A	- / 0.210	- / 5.33
A1	0.010 / -	0.25 / -
A2	0.150 / 0.160	3.81 / 4.06
B	0.016 / 0.022	0.41 / 0.56
B1	0.048 / 0.054	1.22 / 1.37
C	0.008 / 0.014	0.20 / 0.36
D	- / 2.070	- / 52.58
E	0.590 / 0.610	14.99 / 15.49
E1	0.540 / 0.552	13.72 / 14.02
e1	0.090 / 0.110	2.29 / 2.79
L	0.120 / 0.140	3.05 / 3.56
$\alpha$	0° / 15°	0° / 15°
eA	0.630 / 0.670	16.00 / 17.02
S	- / 0.090	- / 2.29

Specifications subject to change without notice, contact your sales representatives for the most recent information.



44L Plastic Leaded Chip Carrier (PLCC)

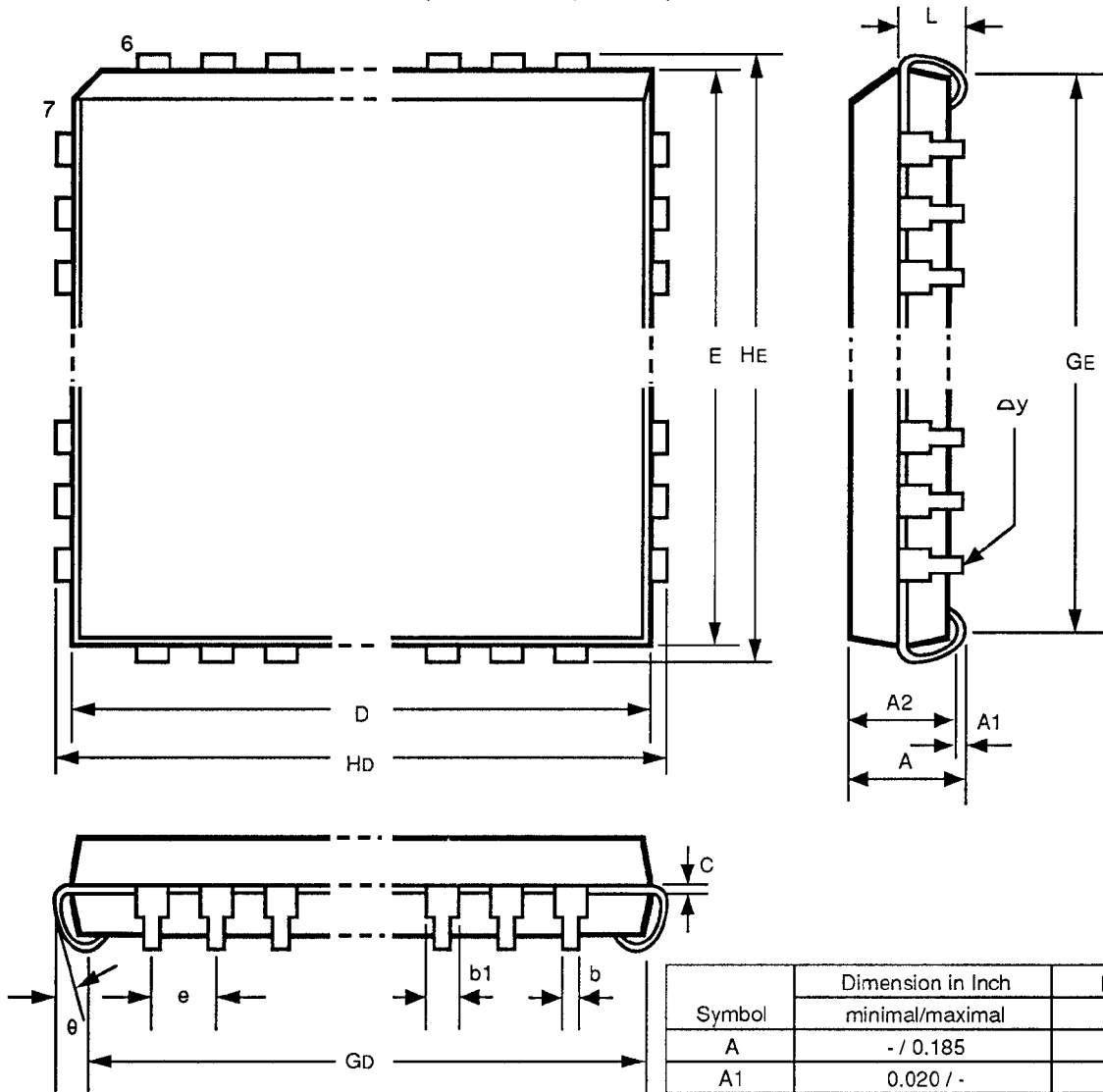

Note:

1. Dimension D & E does not include interlead flash.
2. Dimension b1 does not include dambar protrusion/ intrusion.
3. Controlling dimension: Inch
4. General appearance spec. should base on final visual inspection spec.

Symbol	Dimension in Inch	Dimension in mm
	minimal/maximal	minimal/maximal
A	- / 0.185	- / 4.70
A1	0.020 / -	0.51 / -
A2	0.145 / 0.155	3.68 / 3.94
b1	0.026 / 0.032	0.66 / 0.81
b	0.016 / 0.022	0.41 / 0.56
C	0.008 / 0.014	0.20 / 0.36
D	0.648 / 0.658	16.46 / 16.71
E	0.648 / 0.658	16.46 / 16.71
e	0.050 BSC	1.27BSC
GD	0.590 / 0.630	14.99 / 16.00
GE	0.590 / 0.630	14.99 / 16.00
HD	0.680 / 0.700	17.27 / 17.78
HE	0.680 / 0.700	17.27 / 17.78
L	0.090 / 0.110	2.29 / 2.79
Δy	- / 0.004	- / 0.10
θ	/	/

Specifications subject to change without notice, contact your sales representatives for the most recent information.



Bonding Information

Index	PAD-NAME	X-COORD	Y-COORD
1	P3.6		
2	P3.7		
3	XTAL2		
4	XTAL1		
5	Vss		
6	Vss		
7	Vss		
8	P2.0		
9	P2.1		
10	P2.2		
11	P2.3		
12	P2.4		
13	P2.5		
14	P2.6		
15	P2.7		
16	#FOE		
17	#FCE		
18	#EA		
19	P0.7		
20	P0.6		
21	P0.5		
22	P0.4		

Index	PAD-NAME	X-COORD	Y-COORD
23	P0.3		
24	P0.2		
25	P0.1		
26	P0.0		
27	Vdd		
28	Vdd		
29	Vdd		
30	Vss		
31	P1.0		
32	P1.1		
33	P1.2		
34	P1.3		
35	P1.4		
36	P1.5		
37	P1.6		
38	P1.7		
39	RES		
40	P3.0		
41	P3.1		
42	P3.2		
43	P3.3		
44	P3.4		
45	P3.5		

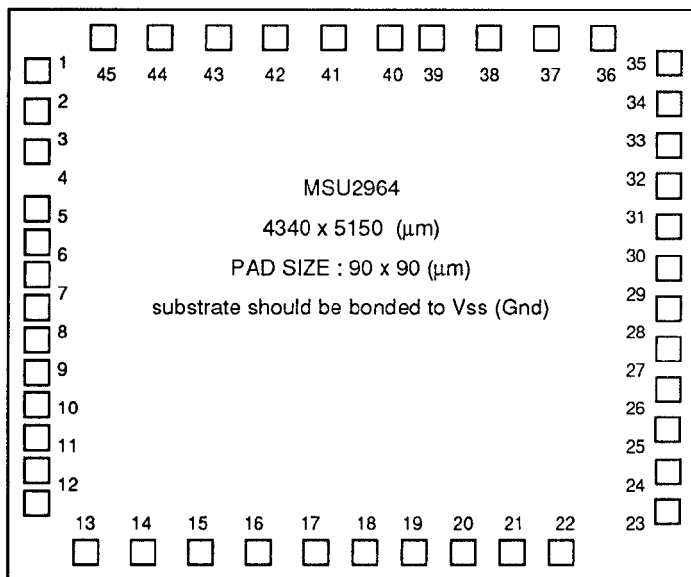

pid 264\* 02/98  
pid 264\*\* 04/98  
pid 264\*\*\* 11/98  
pid 264\*\*\*\* 12/98  
pid 264A 01/99

Taiwan

#1 Creation Road I,  
Science - based Industrial Park,  
Hsinchu, 30077  
Taiwan, ROC  
"leo\_hsieh@mail.mosel.com.tw"  
TEL: 886-3-578-3344  
FAX: 886-3-579-2955  
FAX: 886-3-578-4732

Taipei

7F, #102, Section 3,  
Ming Chuang E. Road,  
Taipei,105  
Taiwan, ROC  
TEL: 886-2-2545-1213  
FAX: 886-2-2545-1214

China

(Vitelc HKG ShenZhen)  
Room #1313, Shenkan Bldg.  
#4 Shangbu road,  
ShenZhen city, 518028,  
P.R.China  
TEL: 86-755-375-5805  
FAX: 86-755-375-5806

Hongkong

#19, Dai Fu Street,  
Taipo Industrial Estate,  
Taipo, N.T.  
Hongkong  
TEL: 852-2665-4883  
FAX: 852-2664-2406  
FAX: 852-2770-8011

U.S.A.

#3910, North First Street,  
San Jose,  
CA. 65134-1501  
U.S.A.  
TEL: 1-408-433-6000  
FAX: 1-408-433-0952

Japan

WBG Marive West 25F  
6, Nakase 2-chome,  
Mihama-ku, Chiba-shi,  
Chiba 261-7125,  
Japan  
TEL: 043-299-6000  
FAX: 043-299-6555

http://www.moselvitelic.com

Specifications subject to change without notice, contact your sales representatives for the most recent information.



To: Mosel Vitelic Inc.  
886-3-578-4732 (fax#)  
Attn: S&M department of Strategic product division

## Logo Top Marking Request & spec.

We hereby request MVI to have our logo printed on top of the device package. Below is the specification of our logo in 20:1 scale base. This logo diagram is clear enough and is able to be shrunk directly to fit into available top marking area described on page.

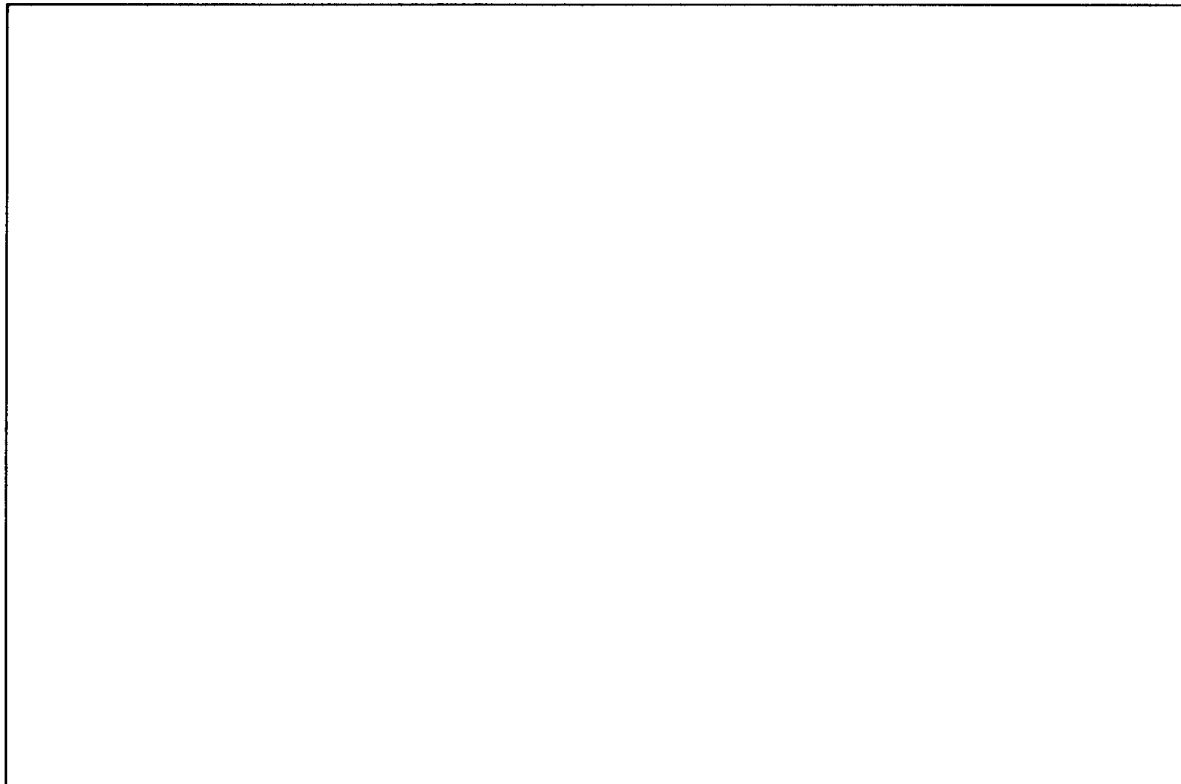

Phone # : \_\_\_\_\_ Fax # : \_\_\_\_\_

Company Name : \_\_\_\_\_

Signature : \_\_\_\_\_

Name (Typed) : \_\_\_\_\_

Position Title : \_\_\_\_\_

Department, Section : \_\_\_\_\_

Signature Date : \_\_\_\_\_

Specifications subject to change without notice, contact your sales representatives for the most recent information.