

Features

- Wide Frequency Range: 50 MHz to 6 GHz, in 3 bands
- Surface Mount SP2T Switch in Compact Outline:
 - 8 mm L x 5 mm W x 2.5 mm H
- Higher Average Power Handling than Plastic Packaged
 - MMIC Switches: 100 W CW
- High RF Peak Power: 500 W
- Low Insertion Loss: 0.30 dB
- High IIP3: 65 dBm
- Operates From Positive Voltage Only: 5 V & -180 V
- RoHS Compliant

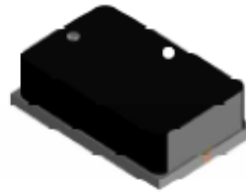

Case Style CS206

Applications

- High Power Transmit/Receive (TR) Switching
- Active Receiver Protection

Description

The MSW2060-206, MSW2061-206, and MSW2062-206 Series of Surface Mount Silicon PIN Diode SP2T Switches is manufactured using Aeroflex/Metelics proven hybrid manufacturing process incorporating High Voltage PIN Diodes and passive devices integrated within a ceramic substrate. This low profile, compact, surface mount component, (8mm L x 5mm W x 2.5 mm H) offers superior low and high signal performance to comparable MMIC devices in QFN packages. The SP2T switches are designed in a symmetrical topology to optimize Insertion Loss and Isolation performance. Using PIN Diodes with lower thermal resistance ($< 10 \text{ }^{\circ}\text{C/W}$), RF C.W. incident power levels of + 50 dBm and RF peak incident power levels of + 57 dBm are very achievable in higher power cold and hot switching applications @ + 85 ° C. The lower PIN Diode series resistance ($< 1.0 \text{ } \Omega$), coupled with the longer minority carrier lifetime, ($> 3 \text{ } \mu\text{S}$), provides better IIP3 distortion values $> + 65 \text{ dBm}$.

These MSW2060-206, MSW2061-206 and MSW2062-206 Series SP2T Switches are designed to be used in higher average and peak power switch applications, operating from 20 MHz to 6000 MHz, requiring high volume, surface mount, solder re-flow manufacturing. These products are durable, reliable, and capable of meeting all military, commercial, and industrial environments. The devices are fully RoHS compliant.

Environmental Capabilities

The MSW2060-206, MSW2061-206, and MSW2062-206 Series SP2T Switches are capable of meeting the environmental requirements of MIL-STD-202 and MIL-STD-750.

ESD and Moisture Sensitivity Level Rating

PIN Diode Switches are susceptible to ESD conditions as with all semiconductors. The ESD rating for this device is Class 1C, HBM. The moisture sensitivity level rating for this device is MSL 2.

Pin Out

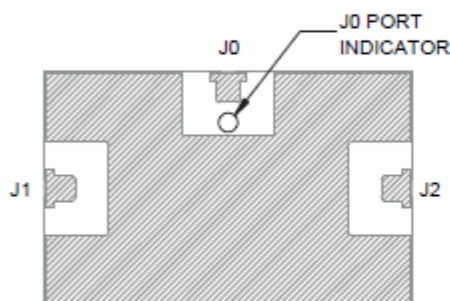

TOP VIEW

Schematic

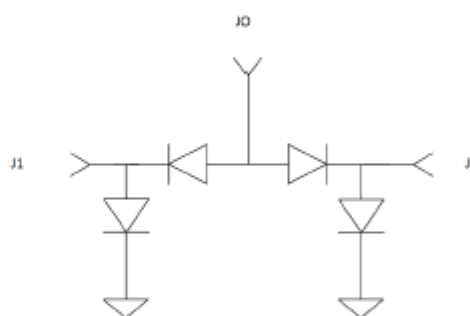

Truth Table for Control of Symmetrical SP2T Switch MSW206x-206 Series

$+V_{CC1} = 5\text{ V}$ and $+V_{CC2} = 28\text{ V}$ (Unless otherwise noted)

Port J0 – J1	Port J0 – J2	Bias:J1	Bias:J2
Low Loss	Isolation	V = -180 V, I = -50 mA	V = 1 V, I = 25 mA
Low Loss	Isolation	V = 1 V, I = 25 mA	V = -180 V, I = -50 mA

MSW2060-206 Electrical Specifications

$Z_0 = 50 \Omega$, $T_A = 25 \text{ }^\circ\text{C}$ (Unless Otherwise Defined)

Parameter	Symbol	Test Conditions	Min. Value	Typ. Value	Max. Value	Units
Frequency	F		20	20-1000	1200	MHz
Insertion Loss	IL	Condition 1: port J0 to J1 Condition 2: port J0 to J2	-	0.25	0.35	dB
Return Loss	RL	Condition 1: port J0 to J1 Condition 2: port J0 to J2	20	23	-	dB
Isolation	Isol	Condition 1: port J0 to J1 Condition 2: port J0 to J2	49	53	-	dB
CW Incident Power (Note 2)	$P_{inc}(CW)$	source & load VSWR = 1.5:1	-	50	-	dBm
Peak Incident Power (Note 2)	$P_{inc}(Pk)$	source & load VSWR = 1.5:1, pulse width = 10 μ s, duty cycle = 1%	-	57	-	dBm
Switching Time (Note 1)	t_{sw}	10% -90% RF voltage, TTL rep rate = 100	-	2	3	μ s
Input 3rd Order Intercept Point	IIP3	$F_1 = 500 \text{ MHz}$, $F_2 = 510 \text{ MHz}$, $P_1 = P_2 = 40 \text{ dBm}$, measured on path biased to low loss state	60	65	-	dBm

MSW2061-206 Electrical Specifications

$Z_0 = 50 \Omega$, $T_A = 25 \text{ }^\circ\text{C}$ (Unless Otherwise Defined)

Parameter	Symbol	Test Conditions	Min. Value	Typ. Value	Max. Value	Units
Frequency	F		200	400-4000	4500	MHz
Insertion Loss	IL	Condition 1: port J0 to J1 Condition 2: port J0 to J2	-	0.5	0.7	dB
Return Loss	RL	Condition 1: port J0 to J1 Condition 2: port J0 to J2	14	16	-	dB
Isolation	Isol	Condition 1: port J0 to J1 Condition 2: port J0 to J2	32	35	-	dB
CW Incident Power (Note 2)	$P_{inc}(CW)$	source & load VSWR = 1.5:1	-	50	-	dBm
Peak Incident Power (Note 2)	$P_{inc}(Pk)$	source & load VSWR = 1.5:1, pulse width = 10 μ s, duty cycle = 1%	-	57	-	dBm
Switching Time (Note 1)	t_{sw}	10% -90% RF voltage, TTL rep rate = 100	-	1	2	μ s
Input 3rd Order Intercept Point	IIP3	$F_1 = 2000 \text{ MHz}$, $F_2 = 2010 \text{ MHz}$, $P_1 = P_2 = 40 \text{ dBm}$, measured on path biased to low loss state	60	65	-	dBm

(continued next page)

MSW2062-206 Electrical Specifications

$Z_0 = 50 \Omega$, $T_A = 25 \text{ }^\circ\text{C}$ (Unless Otherwise Defined)

Parameter	Symbol	Test Conditions	Min. Value	Typ. Value	Max. Value	Units
Frequency	F		1.5	2-6	6.5	GHz
Insertion Loss	IL	Condition 1: port J0 to J1 Condition 2: port J0 to J2	-	0.7	0.9	dB
Return Loss	RL	Condition 1: port J0 to J1 Condition 2: port J0 to J2	11	13	-	dB
Isolation	Isol	Condition 1: port J0 to J1 Condition 2: port J0 to J2	31	34	-	dB
CW Incident Power (Note 2)	$P_{inc}(CW)$	source & load VSWR = 1.5:1	-	50	-	dBm
Peak Incident Power (Note 2)	$P_{inc}(Pk)$	source & load VSWR = 1.5:1, pulse width = 10 μs , duty cycle = 1%	-	57	-	dBm
Switching Time (Note 1)	t_{sw}	10% -90% RF voltage, TTL rep rate = 100	-	1	2	μs
Input 3rd Order Intercept Point	IIP3	$F_1 = 2000 \text{ MHz}$, $F_2 = 2010 \text{ MHz}$, $P_1 = P_2 = 40 \text{ dBm}$, measured on path biased to low loss state	60	65	-	dBm

Conditions:

- | | |
|--|--|
| 1 State 1 (J0 – J1 in low insertion loss state): | 2 State 2 (J0 – J2 in low insertion loss state): |
| a. J1: -50 mA, 180 V (ON) | a. J2: 25 mA, 1 V (OFF) |

Notes:

- Switching time (50% TTL – 10/90% RF Voltage) is a function of the PIN diode driver performance as well as the characteristics of the diode. An RC "current spiking network" is used on the driver output to provide a transient current to rapidly remove stored charge from the PIN diode. Typical component values are: R = 50 to 220 Ω and C = 470 to 1,000 pF. MACOMs MPD2T28125-702 is the recommended PIN diode driver to interface with the MSW2060-206, MSW2061-206, and MSW2062-206 SP2T switches. Its data sheet is available
- PIN diode minimum reverse DC voltage (V_{rev}) to maintain high resistance in the OFF PIN diode is determined by RF frequency, incident power, duty cycle, characteristic impedance and VSWR as well as by the characteristics of the diode. The recommended minimum reverse bias voltage (V_{rev}) values are provided in the Minimum Reverse Bias Voltage table (page 5) of this datasheet.

RF Bias Network Component Values

P/N	F (MHz)	DC Blocking Capacitors	Inductors	RF Bypass Capacitors
MSW2060-206	50 – 1,000	0.1 μ F	4.7 μ H	0.1 μ F
MSW2061-206	400 – 4,000	27 pF	82 nH	270 pF
MSW2062-206	2,000 - 6,000	22 pF	33 nH	33 pF

Minimum Reverse Bias Voltage at TX, RX, DC Ports vs. Signal Frequency

$P_{INC} = 100$ W CW, $Z_0 = 50\Omega$ with 1.5:1 VSWR

Part Number	F = 20 MHz	F = 100 MHz	F = 200 MHz	F = 400 MHz	F = 1 GHz	F = 4 GHz
MSW2060-206	-180 V	-150 V	-110 V	-75 V	-35 V	NA
MSW2061-206	NA	NA	-150 V	-110 V	-55 V	-25 V
MSW2062-206	(F = 1 GHz) -55 V	(F = 2 GHz) -28 V	(F = 3 GHz) -28 V	(F = 4 GHz) -28 V	(F = 5 GHz) -28 V	(F = 6 GHz) -28 V

Note: "NA" denotes the switch is not recommended for use in that frequency band.

Absolute Maximum Ratings

$Z_0 = 50 \Omega$, $T_a = +25 \text{ }^\circ\text{C}$ (Unless Otherwise Defined)

Parameter	Conditions	Absolute Maximum Value
Forward Current - J1 or J2 Port		250 mA
Reverse Voltage - J1 or J2 Port		-300 V
Forward Diode Voltage	$I_f = 250$ mA	1.2 V
Operating Temperature		-65 $^\circ\text{C}$ to 125 $^\circ\text{C}$
Storage Temperature		-65 $^\circ\text{C}$ to 150 $^\circ\text{C}$
Junction Temperature		175 $^\circ\text{C}$
Assembly Temperature	$t = 10$ s	260 $^\circ\text{C}$
CW Incident Power Handling - J0, J1, J2 Port (Note 1+2)	Source & load VSWR = 1.5 :1, $T_{case} = 85 \text{ }^\circ\text{C}$, cold switching	50 dBm
Peak Incident Power Handling - J0, J1, J2 Port (Note 1+2)	Source & load VSWR = 1.5 :1, $T_{case} = 85 \text{ }^\circ\text{C}$, cold switching, pulse width = 10 μ s, duty cycle = 1%	57 dBm
Total Dissipated RF & DC Power (Note 1+2)	$T_{case} = 85 \text{ }^\circ\text{C}$, cold switching	12 W

Notes:

- For Hot Switching, PIN Diode Driver must Transition from Forward Bias to Reverse Bias and Reverse Bias to Forward Bias within 100 ns with a parallel RC spiking network at the Driver Output.
- Backside RF and DC grounding area of device must be completely solder-attached to RF circuit board vias for proper electrical and thermal circuit grounding.

MSW2060-206 Small Signal Typical Performance

$Z_0 = 50 \Omega$, $T_A = +25 \text{ }^\circ\text{C}$ (Unless Otherwise Defined)

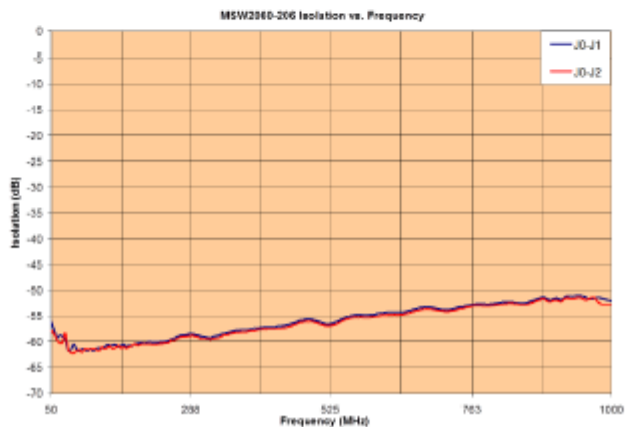
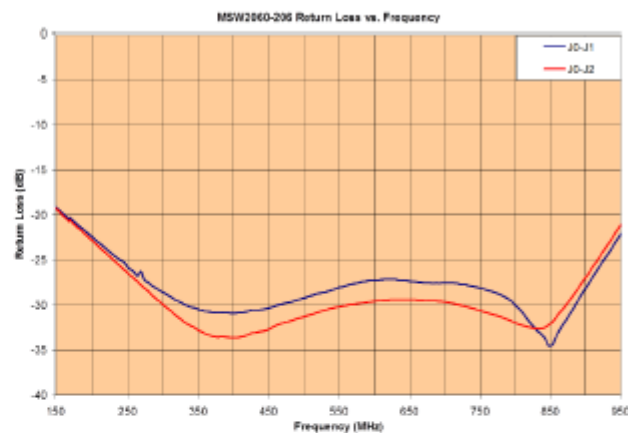
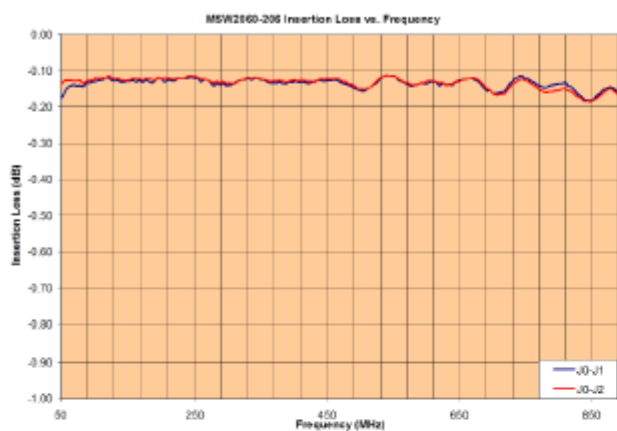

MSW2061-206 Small Signal Typical Performance

$Z_0 = 50 \Omega$, $T_A = +25 \text{ }^\circ\text{C}$ (Unless Otherwise Defined)

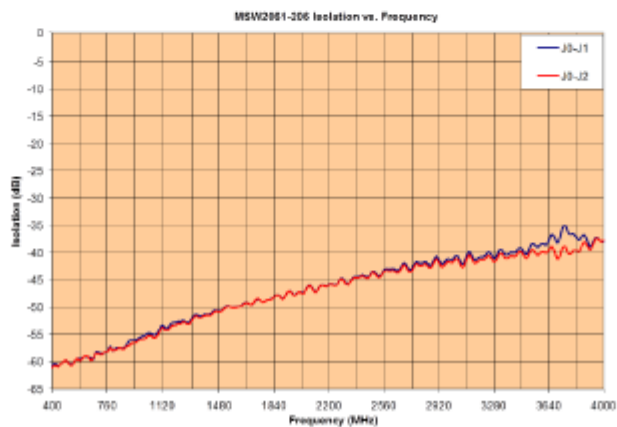
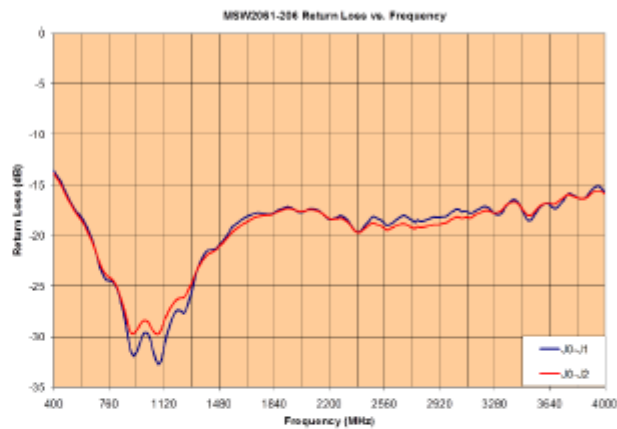
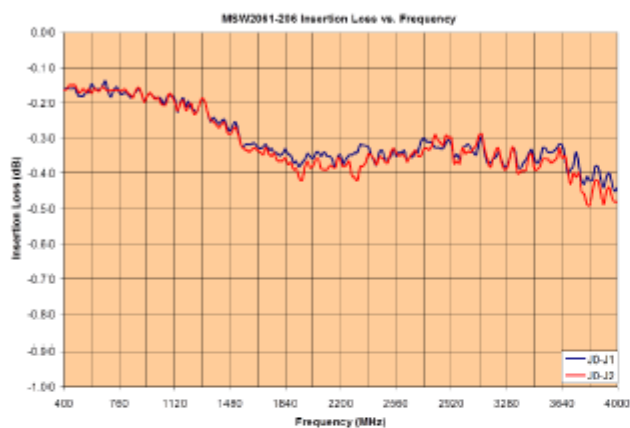

MSW2062-206 Small Signal Typical Performance

$Z_0 = 50 \Omega$, $T_A = +25 \text{ }^\circ\text{C}$ (Unless Otherwise Defined)

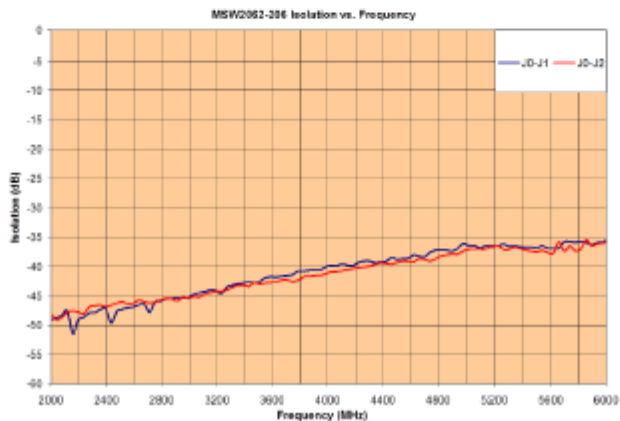
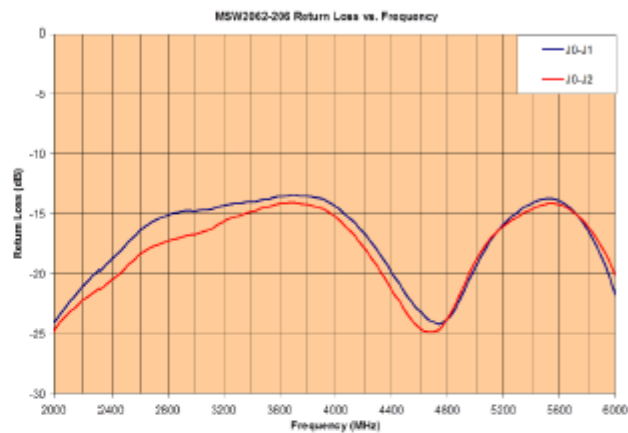
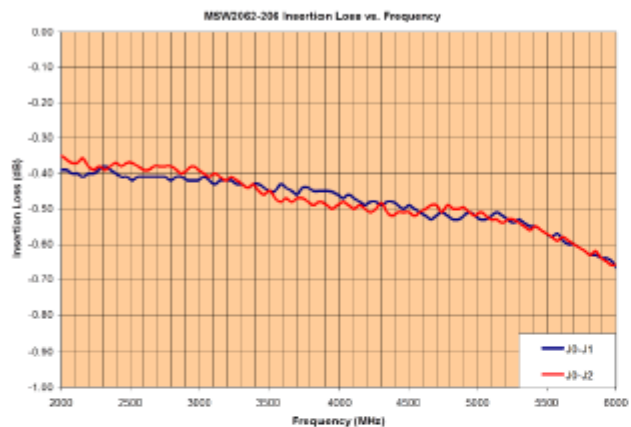

SP2T Switch Evaluation Board Layout

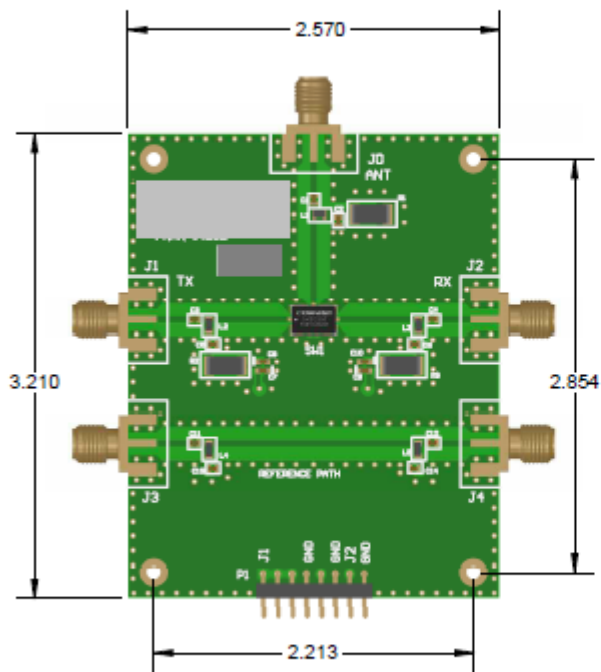

APPLIES TO THE FOLLOWING EVAL BOARDS:
CS206 - BAND 1 / BAND 2

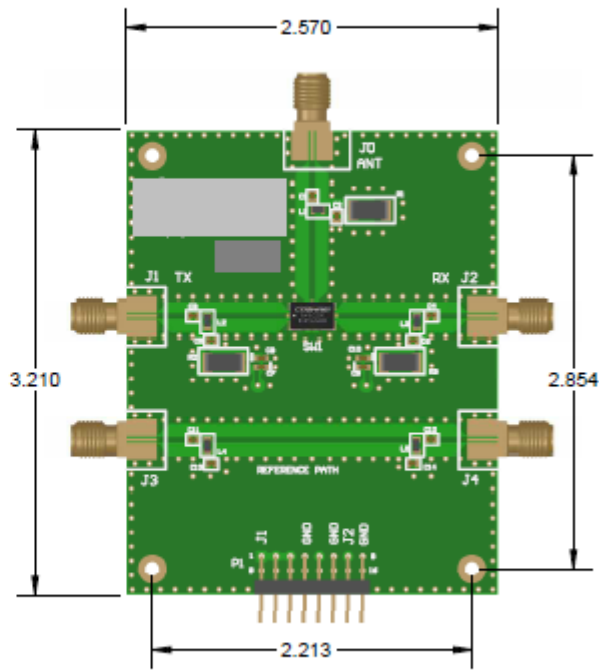

APPLIES TO THE FOLLOWING EVAL BOARDS:
CS206 - BAND 3

MSW2060-206 Band 1 Evaluation Board BOM								
Item	DC Blocking Caps	RF Bypass Caps	Second Bypass Cap (Optional)	Inductor	Resistor	Resistor	Header Pin	SMA Connector
Value	470 pF	470 pF	470 pF	600 Ohm	130Ω	150Ω	8 Pin DC Header	SMA JACK
Location	C1,C3,C4,C11,C12	C2,C5,C6,C13,C14	C7,C8,C9,C10	L1 to L7	R1	R2, R3	P1	J0 - J4
Specs , Mfg	CAP CER,470 pF,50 V , 5% ,NPO ,0603, Johanson Dielectric Inc	CAP CER,470 pF,50 V , 5% ,NPO ,0603, Johanson Dielectric Inc	CAP CER,470 pF,50 V , 5% ,NPO ,0603, Johanson Dielectric Inc	Ferrite Bead, 600 Ohm, 1.0A, 0603, Wirth Electronics Inc	1W, 5%,2512 Thick Film Panasonic	1W, 5%,2512 , Thick Film, Panasonic	8 Pos, Rectangular Head , Male PIN 0.100R/A , 15 AU, FCI	Conn Jack SMA , 50 Ohm Edge Mount , Emerson
Mfg #	500R14N471J V4T	500R14N471 JV4T	500R14N471 JV4T	742792651	ERJ-1TYJ390U	ERJ-1TNF1201U	68016-208HLF	901-10309
Digikey #	709-1150-1-ND	709-1150-1-ND	709-1150-1-ND	732-1593-1-ND	PT39XTR-ND	PT1.20KAFT R-ND	609-3321-ND	ARF1744-ND

MSW2061-206 Band 2 Evaluation Board BOM								
Item	DC Blocking Caps	RF Bypass Caps	Second Bypass Cap (Optional)	Inductor	Resistor	Resistor	Header Pin	SMA Connector
Value	47 pF	220 pF	1000 pF	43 nH	150Ω	130Ω	8 Pin DC Header	SMA JACK
Location	C1,C3,C4, C11 ,C12	C2,C5,C6,C13,C14	C7,C8,C9, C10	L1 to L5	R2, R3	R1	P1	J0 - J4
Specs , Mfg	CAP CER,47 pF,50 V , 5% ,NPO ,0603, Johanson Dielectric Inc	CAP CER,220 pF,50 V , 5% ,NPO ,0603, Johanson Dielectric Inc	CAP CER,470 pF,50 V , 10% ,NPO ,0603, X7R , Murata Electronics	RF Chip Inductor , 5%, 0603, Q min = 38, SRF min = 2 GHz, DCR Max (ohms)= 0.280, Ims(mA)= 600mA, CoilCraft.	1W, 5%,2512 Thick Film Panasonic	1W, 1%,2512 , Thick Film, Panasonic	8 Pos, Rectangular Head , Male PIN 0.100R/A , 15 AU, FCI	Conn Jack SMA , 50 Ohm Edge Mount , Amphenol -RF Division
Mfg #	500R14N470J V4T	500R14N221 JV4T	500R14N102 JV4T	0603CS-43NXJLU	ERJ-1TYJ151U	ERJ-1TNF131U	68016-208HLF	901-10309
Digikey #	709-1145-1-ND	709-1148-1-ND	709-1151-1-ND	N/A	PT150XTR-ND	PT130XTR-ND	609-3321-ND	ARF1744-ND

MSW2062-206 Band 3 Evaluation Board BOM								
Item	DC Blocking Caps	RF Bypass Caps	Second Bypass Cap (Optional)	Inductor	Resistor	Resistor	Header Pin	SMA Connector
Value	10 pF	33 pF	1000 pF	8.2 nH	130Ω	150Ω	16 Pin DC Header	SMA JACK
Location	C1,C3,C4,C11, C12	C2,C5,C6, C13,C14	C7,C8, C9,C10	L1 to L5	R1	R2, R3	P1	J0 - J4
Specs , Mfg	CAP CER,10 pF,50 V , 5% ,NPO ,0603 Johanson Dielectric Inc	CAP CER,33 pF,50 V , 5% ,NPO ,0603 Panasonic	CAP CER,1000 pF,50 V , 10% ,NPO ,0603 Murata Electronics	8.2nH @250MHz, SRF=4.7 GHz,DCR Max = 0.115, Irms (mA)= 700, Coil Craft	1W, 5%,2512 Thick Film Panasonic	1W, 1%,2512 Thick Film, Panasonic	16 Pos, Rectangular Head , Male PIN 0.100R/A , 15 AU, FC	Conn Jack SMA , 50 Ohm Edge Mount , Emerson
Mfg #	500R14N100J V4T	ECJ-1VC1H330J	GRM188R71 H102KA01D	0603CS-8N2XJL	ERJ-1TYJ131U	ERJ-1TY0151U	68021-216HLF	142-0761-871
Digikey #	709-1140-1-ND	PCC330ACVT R-ND	490-1494-2-ND	Not Applicable	PT130XTR-ND	PT150XTR-ND	609-3346-ND	J806-ND

Assembly Instructions

The MSW2060-206, MSW2061-206, and MSW2062-206 Switches are capable of being placed onto circuit boards with pick and place manufacturing equipment from tube or tape-reel dispensing. The devices are attached to the circuit board using conventional solder re-flow or wave soldering procedures with RoHS type or Sn 63 / Pb 37 type solders per Table I and Graph I Time-Temperature recommended profile.

Table 1. Time-Temperature Profile for Sn60/Pb40 or RoHS Type Solders

Profile Feature	SnPb Solder Assembly	Pb-Free Solder Assembly
Average Ramp-Up Rate (T_L to T_p)	3 °C /second maximum	3 °C /second maximum
Preheat:		
- Temperature Min (T_{pre})	100 °C	150 °C
- Temperature Max (T_{pre})	150 °C	200 °C
- Time (min to max)(t_p)	60-120 s	60-180 s
T_{max} to T_L		
- Ramp-Up Rate		3 °C/s maximum
Time Maintained Above:		
- Temperature (T_L) - Time (t_L)	183 °C 60-150 s	217 °C 60-150 s
Peak temperature (T_p)	225 +0/-5 °C	260 +0/-5 °C
Time Within 5 °C of Actual Peak Temperature (t_p)	10 – 30 s	20 – 40 s
Ramp-Down Rate	6 °C /s maximum	6 °C /s maximum
Time 25 °C to Peak Temperature	6 minutes maximum	8 minutes maximum

Figure 1. Solder Re-Flow Time-Temperature Profile

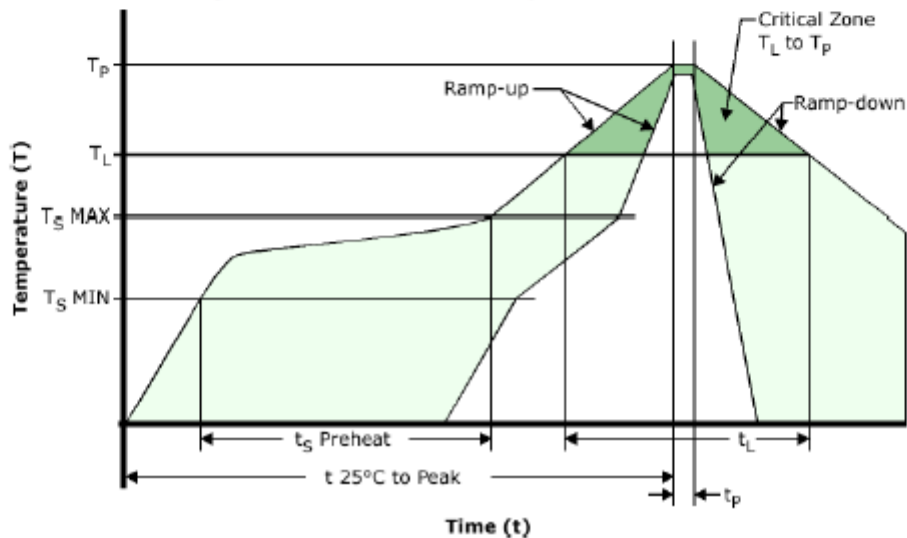

MSW2060-206, MSW2061-206, and MSW2062-206 SP2T Switch Outline (CS206)

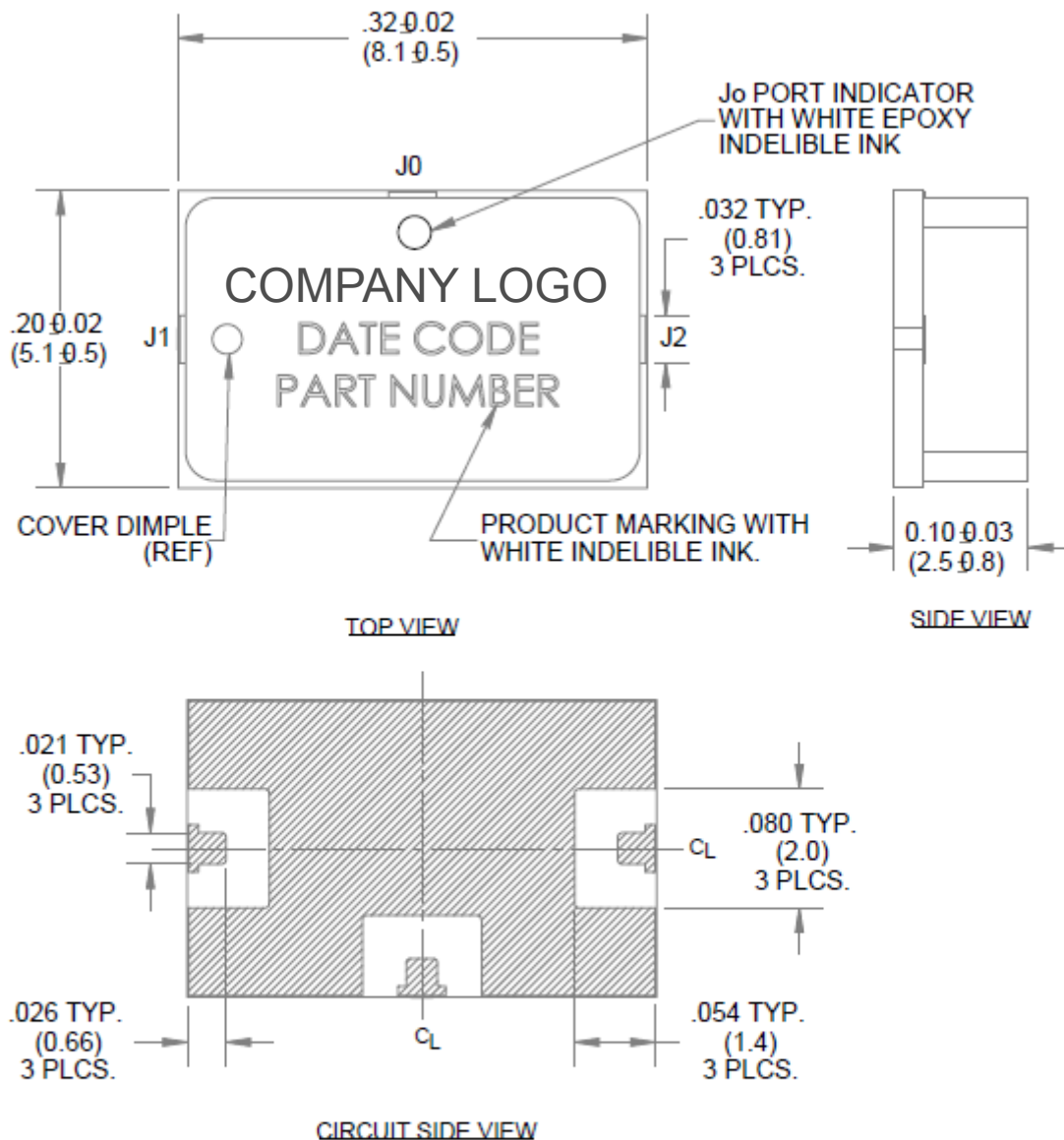

Notes:

1. Hatched metal area on circuit side of device is RF, DC and thermal ground.

RF Circuit Solder Footprint for Case Style 206 (CS206)

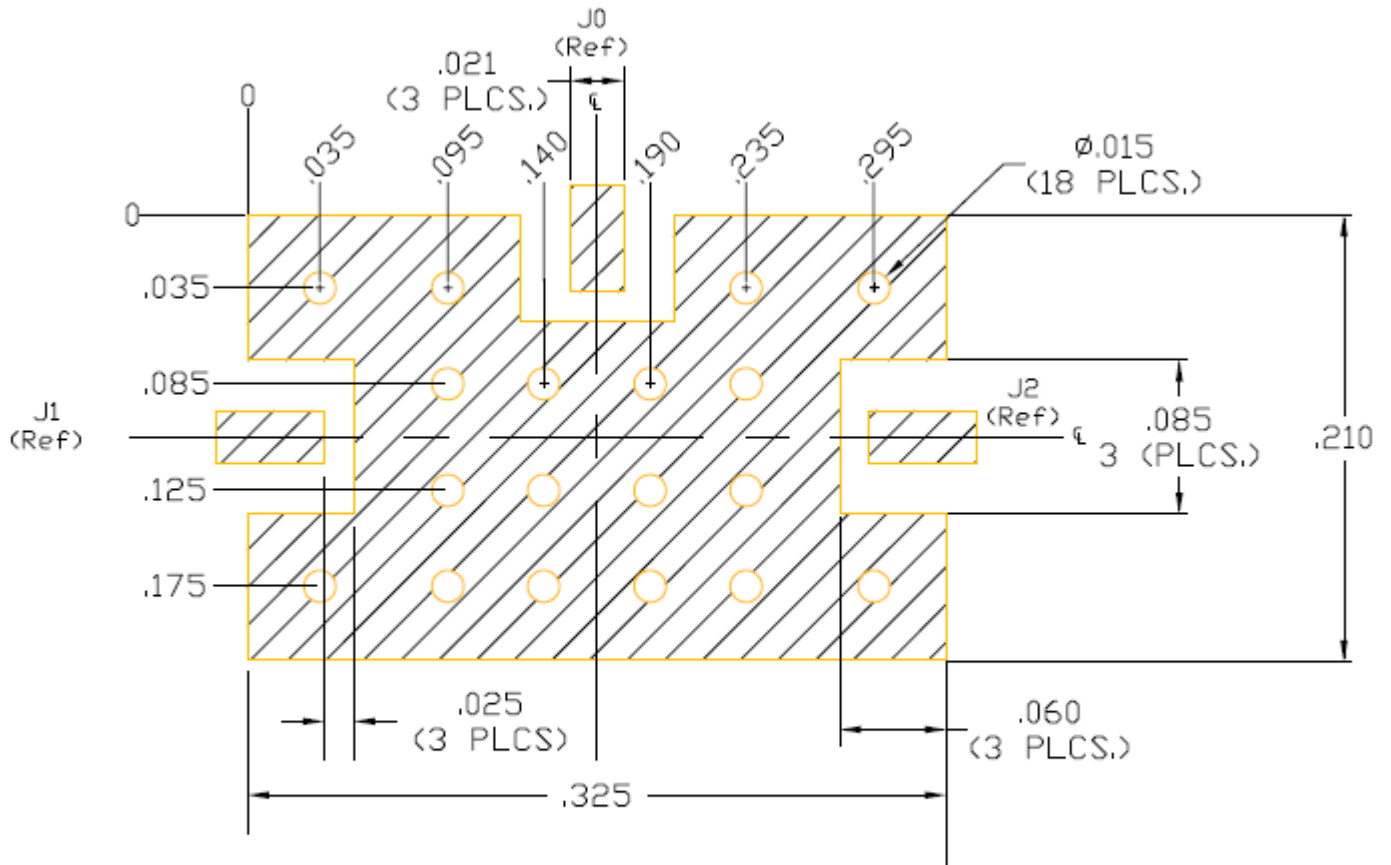

Hatched area is RF, DC, and thermal Ground. Vias should be solid copper fill and gold plated for optimum heat transfer from backside of switch module through Circuit Vias to metal thermal ground.

Part Number Ordering Information

Part Number	Description	Packaging
MSW2060-206-T		Tube
MSW2060-206-R		Tape-Reel (Quantities of 250 or 500)
MSW2060-206-W		Waffle Pack
MSW2061-206-T		Tube
MSW2061-206-R		Tape-Reel (Quantities of 250 or 500)
MSW2061-206-W		Waffle Pack
MSW2062-206-T		Tube
MSW2062-206-R		Tape-Reel (Quantities of 250 or 500)
MSW2062-206-W		Waffle Pack
MSW2060-206-E		RF Evaluation Board
MSW2061-206-E		RF Evaluation Board
MSW2062-206-E		RF Evaluation Board

M/A-COM Technology Solutions Inc. All rights reserved.

Information in this document is provided in connection with M/A-COM Technology Solutions Inc ("MACOM") products. These materials are provided by MACOM as a service to its customers and may be used for informational purposes only. Except as provided in MACOM's Terms and Conditions of Sale for such products or in any separate agreement related to this document, MACOM assumes no liability whatsoever. MACOM assumes no responsibility for errors or omissions in these materials. MACOM may make changes to specifications and product descriptions at any time, without notice. MACOM makes no commitment to update the information and shall have no responsibility whatsoever for conflicts or incompatibilities arising from future changes to its specifications and product descriptions. No license, express or implied, by estoppel or otherwise, to any intellectual property rights is granted by this document.

THESE MATERIALS ARE PROVIDED "AS IS" WITHOUT WARRANTY OF ANY KIND, EITHER EXPRESS OR IMPLIED, RELATING TO SALE AND/OR USE OF MACOM PRODUCTS INCLUDING LIABILITY OR WARRANTIES RELATING TO FITNESS FOR A PARTICULAR PURPOSE, CONSEQUENTIAL OR INCIDENTAL DAMAGES, MERCHANTABILITY, OR INFRINGEMENT OF ANY PATENT, COPYRIGHT OR OTHER INTELLECTUAL PROPERTY RIGHT. MACOM FURTHER DOES NOT WARRANT THE ACCURACY OR COMPLETENESS OF THE INFORMATION, TEXT, GRAPHICS OR OTHER ITEMS CONTAINED WITHIN THESE MATERIALS. MACOM SHALL NOT BE LIABLE FOR ANY SPECIAL, INDIRECT, INCIDENTAL, OR CONSEQUENTIAL DAMAGES, INCLUDING WITHOUT LIMITATION, LOST REVENUES OR LOST PROFITS, WHICH MAY RESULT FROM THE USE OF THESE MATERIALS.

MACOM products are not intended for use in medical, lifesaving or life sustaining applications. MACOM customers using or selling MACOM products for use in such applications do so at their own risk and agree to fully indemnify MACOM for any damages resulting from such improper use or sale.