

1A LDO Linear Voltage Regulator**◆ DESCRIPTION**

The MT1117 is a low dropout three-terminal regulator with 1 A output current capability. In order to obtain lower dropout voltage and fast transient response, which is critical for low voltage applications. The MT1117 has been optimized. The device is available in an adjustable version and fixed output voltage of 1.5V, 1.8V, 2.5V, 3.3V and 5V. Dropout voltage is guaranteed at a maximum of 1.3V at 1A.

Current limit is trimmed to ensure specified output current and controlled short circuit current. On-chip thermal limiting provides protection against any combination of overload that would create excessive junction temperatures.

The MT1117 is characterized under junction temperature from -40°C to 150°C. The MT1117 is available in the three leads SOT-223 and To-252 surface mount packages.

◆ FEATURES

- Adjustable or fixed Output
- Current Limit and Thermal Protection
- Output Current of 1A
- 1.3V Dropout Voltage
- Line Regulation typically at 0.04% Max
- Low Quiescent Current:3 mA (Typ.)
- Halogen Free Process

◆ APPLICATIONS

- Battery Chargers
- Post Regulator for Switching Power Supply
- Low Voltage Logic Suppliers

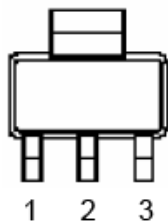
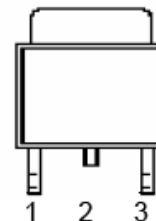
◆ PIN CONFIGURATIONS**SOT-223** (Top View)**MT1117-X.XA** 1:GND/ADJ, 2:OUT, 3:IN**TO-252** (Top View)**MT1117-X.XB** 1:GND/ADJ, 2:OUT, 3:IN

1A LDO Linear Voltage Regulator
◆ ABSOLUTE MAXIMUM RATINGS

Parameter	Symbol	Maximum	Unit
Power Dissipation	P_D	Internally Limited	W
Input voltage	V_{IN}	13	V
Thermal resistance junction to case	θ_{JC}	15	$^{\circ}C/W$
SOT-223		10	$^{\circ}C/W$
Thermal resistance junction to case	θ_{JA}	136	$^{\circ}C/W$
SOT-223		80	$^{\circ}C/W$
TO-252			
Operating junction temperature range	T_J	-40 to 150	$^{\circ}C$
Storage temperature range	T_{STG}	-40 to 150	$^{\circ}C$
Lead temperature (soldering) 10sec	T_{LEAD}	260	$^{\circ}C$

Note:

Exceeding these ratings could cause damage to the device. All voltages are with respect to Ground. Currents are positive into, negative out of the specified terminal.

◆ ORDERING INFORMATION

Device	Package		Vout Volts
MT1117-X.X A	A	SOT-223	X.X_ 1.5 / 1.8 / 2.5 / 2.8 / 3.0 / 3.3 / ADJ
MT1117-X.X B	B	TO-252	X.X_ 1.5 / 1.8 / 2.5 / 2.8 / 3.0 / 3.3 / ADJ

◆ POWER DISSIPATION TABLE

Package	θ_{JA} ($^{\circ}C/W$)	Df(mW/ $^{\circ}C$) $T_A \geq 25^{\circ}C$	$T_A \leq 25^{\circ}C$ Power rating(mW)	$T_A = 70^{\circ}C$ Power rating(mW)	$T_A = 85^{\circ}C$ Power rating (mW)
A	136	7.35	919	588	478
B	80	12.5	1562	1000	812

Note :

- θ_{JA} : Thermal Resistance-Junction to Ambient, D_F : Derating factor, P_o: Power consumption.

Junction Temperature Calculation:

$$T_J = T_A + (P_D \times \theta_{JA}), P_o = D_F \times (T_J - T_A)$$

The θ_{JA} numbers are guidelines for the thermal performance of the device/PC-board system.

All of the above assume no ambient airflow.

- θ_{JT} : Thermal Resistance-Junction to Ambient, T_C: case(Tab) temperature, T_J = T_C + (P_d × θ_{JT})

For A package, $\theta_{JT} = 15.0^{\circ}C/W$.

For B package, $\theta_{JT} = 7.0^{\circ}C/W$.

1A LDO Linear Voltage Regulator
◆ RECOMMENDED OPERATING CONDITIONS

Parameter	Symbol	Operating Conditions			Unit
		Min.	Typ.	Max.	
Input Voltage	V_{IN}	$V_{OUT}+1.4$	-	12	V
Load Current (with adequate heat sinking)	I_O	5	-	-	mA
Input Capacitor (V_{IN} to GND)	C_{IN}	1.0	-	-	μF
Output Capacitor with ESR of 10Ω max., (V_{OUT} to GND)	C_{OUT}	4.7	-	-	μF
Junction temperature	T_J	-	-	150	$^{\circ}C$

◆ ELECTRICAL CHARACTERISTICS

Operating Conditions: $V_{IN} \leq 8V, V_{IN,MIN} - V_{OUT} = 1.5V, I_{OUT} = 10\text{ mA}, T_A = 25^{\circ}C$, unless otherwise specified. ($C_{OUT} = 22\mu F, C_{IN} = 10\mu F$).

Parameter	Symbol	Test Conditions	Min.	Typ.	Max.	Unit
Output Voltage ⁽¹⁾	V_O	$I_O = 10\text{mA}, T_A = 25^{\circ}C,$ MT1117-1.5, $3.0V \leq V_{IN} \leq 5.5V$	1.470	1.50	1.530	V
		MT1117-1.8, $3.0V \leq V_{IN} \leq 5.5V$	1.764	1.80	1.836	V
		MT1117-2.5, $3.5V \leq V_{IN} \leq 5.5V$	2.450	2.50	2.550	V
		MT1117-2.8, $3.8V \leq V_{IN} \leq 5.5V$	2.744	2.80	2.856	V
		MT1117-3.0, $4.0V \leq V_{IN} \leq 5.5V$	2.940	3.00	3.060	V
		MT1117-3.3, $4.3V \leq V_{IN} \leq 5.5V$	3.234	3.30	3.366	V
Reference Voltage	V_{REF}	MT1117-ADJ $V_{IN} = 2.75V, I_{LOAD} = 10\text{mA}$	1.238	1.250	1.262	V
		MT1117-ADJ $V_{IN} = 2.7V \text{ to } 12V, I_{LOAD} = 10\text{mA To } 1A$	1.225	1.250	1.275	V
Line Regulation ⁽¹⁾	V_{SR}	$(V_{OUT} + 1.5V) \leq V_{IN} \leq 8V$ $I_{OUT} = 10\text{mA}$	-	0.3	-	%
Load Regulation ⁽¹⁾	V_{LR}	$(V_{IN} - V_{OUT}) = 1.5V, 10\text{mA} \leq I_{OUT} \leq 1A$	-	0.5	-	%
Dropout Voltage ⁽²⁾	V_D	$V_{IN} = V_{OUT} + 1.5V, I_{OUT} = 1A$	-	1.3	-	V
Current Limit	I_{CL}		-	1.8	-	A
Quiescent Current	I_Q	Fixed Output Version	-	3	-	mA
Minimum Load Current	I_O		-	0.4	-	mA
Ripple Rejection Ratio	PSRR	$f = 120\text{Hz}, I_{OUT} = 0.1A$ $C_{OUT} = 22\mu(\text{Tantalum}), (V_{IN} - V_{OUT}) = 3V,$	-	57	-	dB

NOTES:

(1) Low duty cycle pulse testing with which T_J remain unchanged.

(2) $\Delta V_{OUT}, \Delta V_{REF} = 1\%$

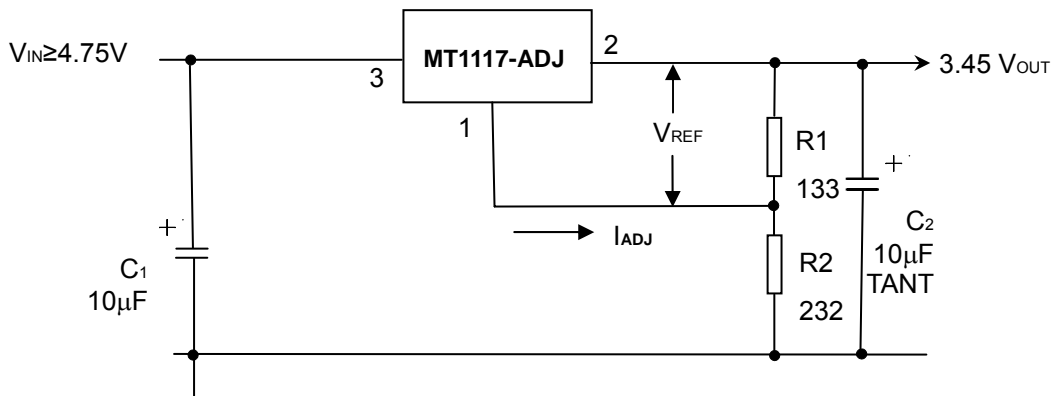
1A LDO Linear Voltage Regulator
◆ TYPICAL APPLICATIONS
Adjustable Voltage Regulator:

Figure1. Adjustable Voltage Regulator

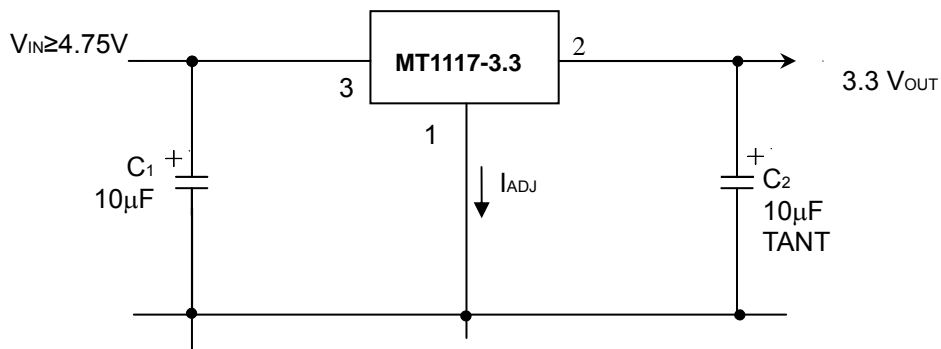
$$V_{OUT} = V_{REF} (1 + R2/R1) + I_{ADJ}R2$$

Fixed Voltage Regulator:

Figure2. Fixed Voltage Regulator

1A LDO Linear Voltage Regulator**◆ APPLICATION NOTE****Maximum Power Dissipation Calculation:**

$$P_D (\text{max}) = [(V_{IN} (\text{max}) - V_O (\text{nom})) \times I_O (\text{nom}) + V_{IN} (\text{max}) \times I_Q]$$

Where: $V_O (\text{nom})$: The nominal output voltage

$I_O (\text{nom})$: The nominal output current, and

I_Q : The quiescent current the regulator consumes at $I_O (\text{max})$

$V_{IN} (\text{max})$: The maximum input voltage

Then $\theta_{JA} = (150^\circ\text{C} - T_A) / P_D$

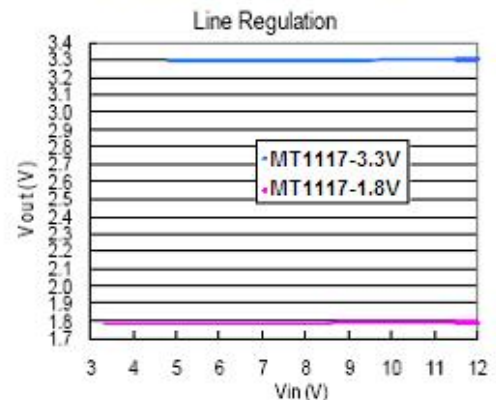
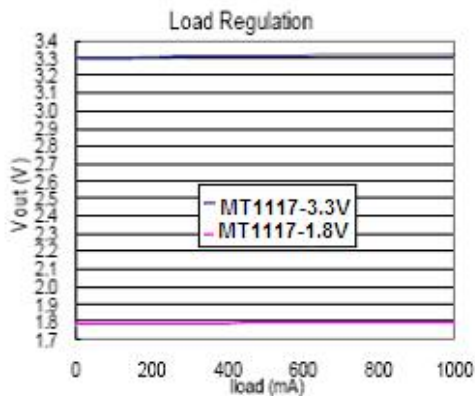
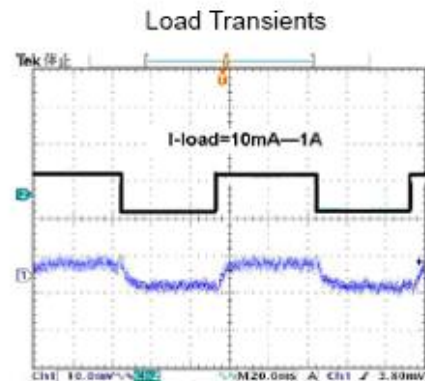
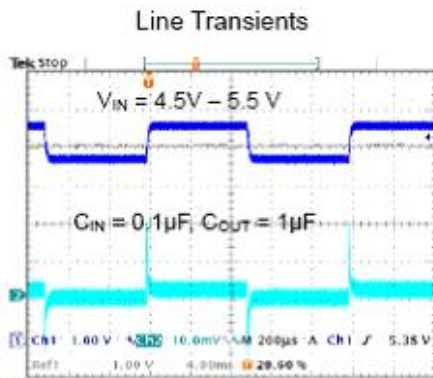
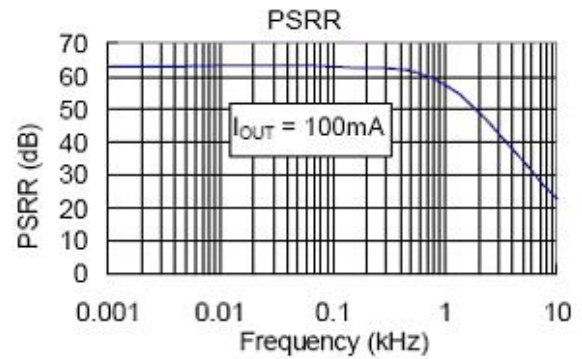
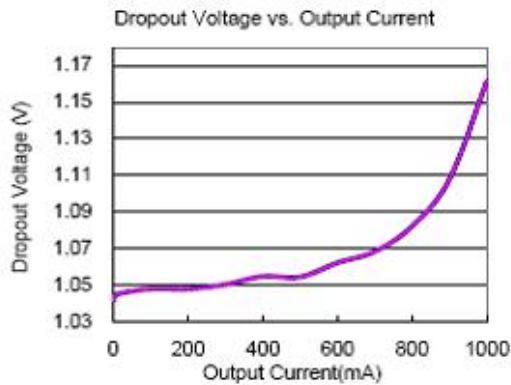
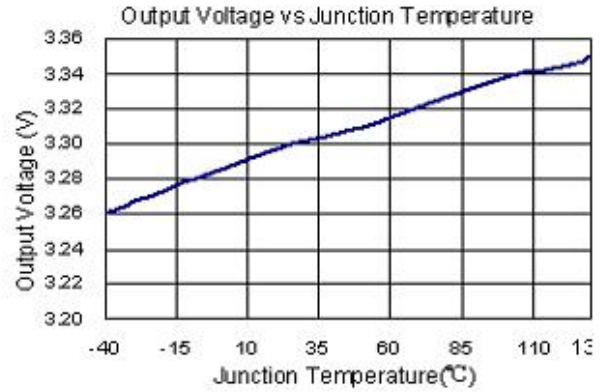
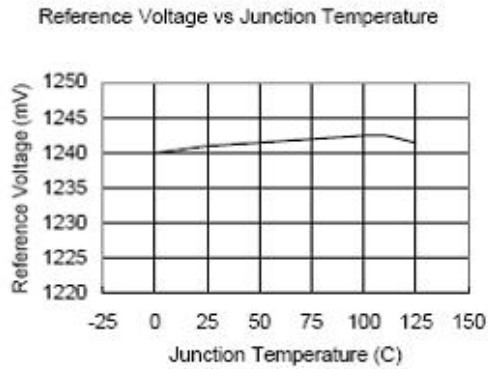
1A LDO Linear Voltage Regulator
◆ TYPICAL PERFORMANCE CHARACTERISTICS

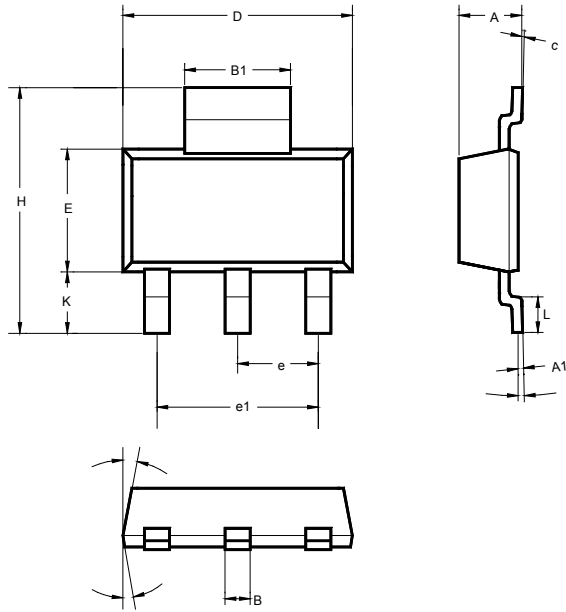
1A LDO Linear Voltage Regulator
◆ PHYSICAL DIMENSIONS
3-Pin Surface Mount SOT-223(A)

	MILLIMETERS		
	MIN	TYP	MAX
A	1.50	1.65	1.80
A1	0.02	0.05	0.08
B	0.60	0.70	0.80
B1	2.90	-	3.15
c	0.28	0.30	0.32
D	6.30	6.50	6.70
E	3.30	3.50	3.70
e	2.3 BSC		
e1	4.6 BSC		
H	6.70	7.00	7.30
L	0.91	1.00	1.10
K	1.50	1.75	2.00
α	0°	5°	10°
β		3°	

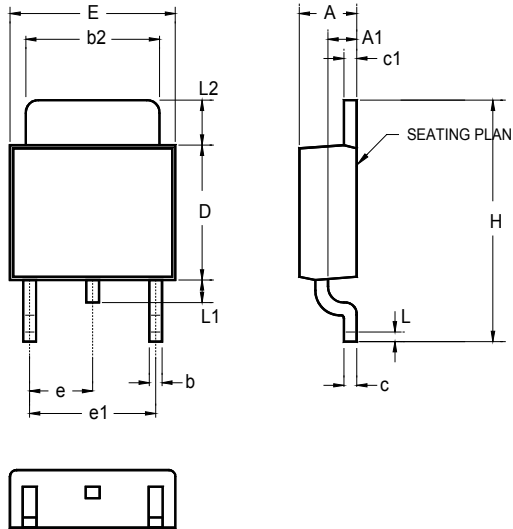
1A LDO Linear Voltage Regulator
◆ PHYSICAL DIMENSIONS
3-Pin Surface Mount TO-252 (B)

	INCHES			MILLIMETERS		
	MIN	TYP	MAX	MIN	TYP	MAX
A	0.086	-	0.094	2.18	-	2.39
A1	0.040	-	0.050	1.02	-	1.27
b	-	0.024	-	-	0.61	-
b2	0.205	-	0.215	5.21	-	5.46
c	0.018	-	0.023	0.46	-	0.58
c1	0.018	-	0.023	0.46	-	0.58
D	0.210	-	0.220	5.33	-	5.59
E	0.250	-	0.265	6.35	-	6.73
e	0.090 BSC			2.29 BSC		
e1	0.180 BSC			4.58 BSC		
H	0.370	-	0.410	9.40	-	10.41
L	0.020	-	-	0.51	-	-
L1	0.025	-	0.040	0.64	-	1.02
L2	0.060	-	0.080	1.52	-	2.03