

INNOLUX DISPLAY CORPORATION

MT170EN01 v.0 LCD MODULE SPECIFICATION

Preliminary

Version 02

Customer Approval: _____

Approved By: _____

Prepare by: _____

Innolux Display Corporation,

No.160 Kesyue Rd., Chu-Nan Site, Hsinchu Science Park,

Chu-Nan 350 , Miao-Li County, Taiwan

Tel: 886-37-586000

Fax: 886-37-586060

InnoLux copyright 2004

All rights reserved,

Copying forbidden.

Record of Revision

Version	Revise Date	Page	Content
01	2004-08-23		First edition to all
02	2004-08-26	11	Revise backlight connector lamp high voltage cable color from white to pink
		11	Revise backlight connector lamp low voltage cable color from black to white
		14	Revises note 9 cross talk graph wording from 32 gray level to 128 gray level
		19	Revise module number and product number

SPEC NO.

PAGE 3/22

Contents:	
A. General Specification	
B. Electrical Specifications	
1. Pin assignment	
2. Absolute maximum ratings	
3. Electrical characteristics	
a. Typical operating conditions	
b. Display color v.s. input data signals	
c. Input signal timing	
d. Display position	
e. Backlight driving conditions	
C. Optical specifications	
D. Reliability test items	
E. Safety	
F. Display quality	
G. Handling precaution	
H. Label	
I. Packing form	
J. Mechanical drawings	
Appendix	

SPEC NO.

PAGE 4/22

A. General specification

NO.	Item	Specification	Remark
1	Display resolution (pixel)	1280(H) X 1024(V), SXGA resolution	
2	Active area (mm)	337.9(H) X 270.3(V)	
3	Screen size (inch)	17 inches diagonal	
4	Pixel pitch (mm)	0.264(H) X 0.264(V)	
5	Color configuration	R, G, B vertical stripe	
6	Overall dimension (mm)	358.5(W)x296.5(H)x17.5(D) Max	
7	Weight (g)	2000 max	
8	Surface treatment	Anti-glare, Haze = 25%, Hard coating (3H)	
9	Display color signal	8 bit LVDS	
10	Color saturation	72% NTSC	
11	Display colors	16.2M colors	
12	Optimum viewing direction	6 o'clock	
13	Backlight	4 CCFL, top & bottom edge side	

SPEC NO.

PAGE 5/22

B. Electrical specifications

1.Pin assignment

Connector JAE FI-X30SSL-HF or equivalent

Pin No	Symbol	Description	
1	RxO0-	LVDS Differential data input Channel 0(-)	Odd Pixel Data
2	RxO0+	LVDS Differential data input Channel 0(+)	
3	RxO1-	LVDS Differential data input Channel 1(-)	
4	RxO1+	LVDS Differential data input Channel 1(+)	
5	RxO2-	LVDS Differential data input Channel 2(-)	
6	RxO2+	LVDS Differential data input Channel 2(+)	
7	GND	Ground	
8	RxOC-	LVDS Differential Clock input (-)	
9	RxOC+	LVDS Differential Clock input (+)	
10	RxO3-	LVDS Differential data input Channel 3(-)	Even Pixel Data
11	RxO3+	LVDS Differential data input Channel 3(+)	
12	RxE0-	LVDS Differential data input Channel 0(-)	
13	RxE0+	LVDS Differential data input Channel 0(+)	
14	GND	Ground	
15	RxE1-	LVDS Differential data input Channel 1(-)	
16	RxE1+	LVDS Differential data input Channel 1(+)	
17	GND	Ground	
18	RxE2-	LVDS Differential data input Channel 2(-)	
19	RxE2+	LVDS Differential data input Channel 2(+)	
20	RxEC-	LVDS Differential Clock input (-)	
21	RxEC+	LVDS Differential Clock input (+)	
22	RxE3-	LVDS Differential data input Channel 3(-)	
23	RxE3+	LVDS Differential data input Channel 3(+)	
24	GND	Ground	
25	GND	Ground	
26	GND	Ground or Open	
27	GND	Ground	
28	VCC	Power supply (+5.0V)	
29	VCC	Power supply (+5.0V)	
30	VCC	Power supply (+5.0V)	

ALL RIGHTS STRICTLY RESERVED. ANY PORTION OF THIS PRPER SHALL NOT BE REPRODUCED, COPIED, OR TRANSFORMED TO ANY OTHER FORMS WITHOUT PERMISSION FROM INNOLUX DISPLAY CORPORATION.

SPEC NO.

PAGE 6/22

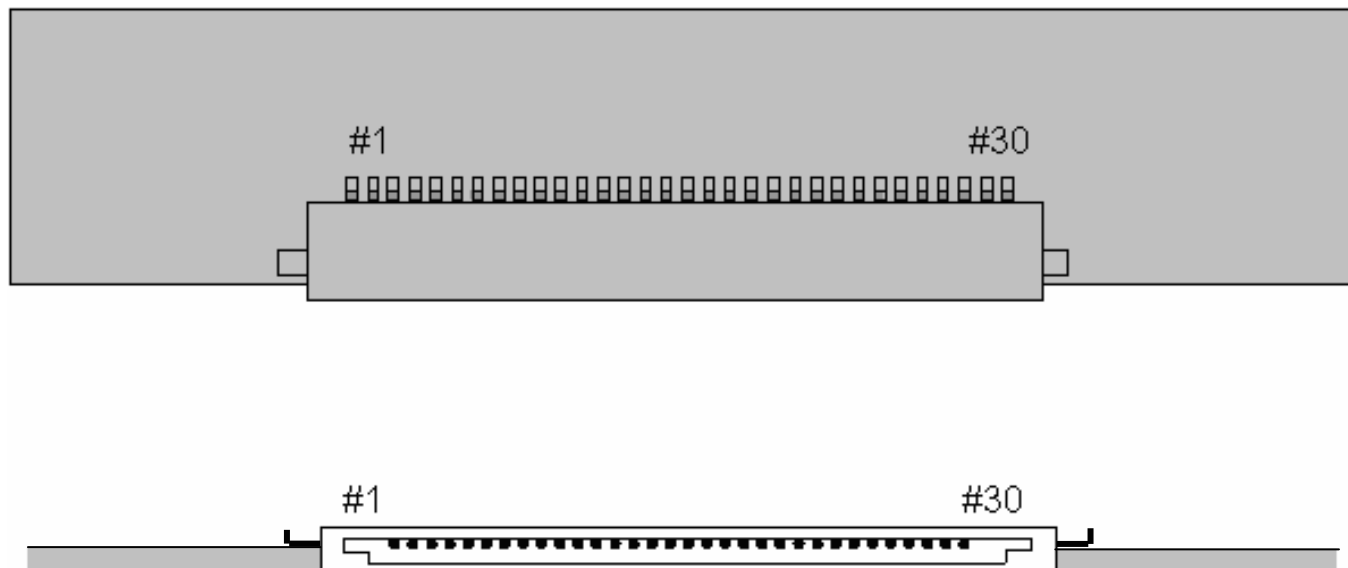

Rear view of LCM

2. Absolute maximum ratings

Parameter	Symbol	Values		Unit	Remark
		Min.	Max.		
Power voltage	V_{DD}	- 0.3	7.0	V	At 25
Input signal voltage	V_{LH}	- 0.3	3.6	V	At 25
Operating temperature	T_{op}	0	50		Note 1
Storage temperature	T_{ST}	- 20	60		Note 2
CCFL Current	ICFL	6.5	8	[mA] rms	
Re-screw			5	Times	
Assured Torque at Side Mount			4	[kgf.cm]	

Note 1: The relative humidity must not exceed 90% non-condensing at temperatures of 40 °C or less. At temperatures greater than 40 °C, the wet bulb temperature must not exceed 39 °C.

Note 2: The unit should not be exposed to corrosive chemicals.

3. Electrical characteristics

ALL RIGHTS STRICTLY RESERVED. ANY PORTION OF THIS PRPER SHALL NOT BE REPRODUCED, COPIED, OR TRANSFORMED TO ANY OTHER FORMS WITHOUT PERMISSION FROM INNOLUX DISPLAY CORPORATION.



SPEC NO.

PAGE 7/22

a. Typical operating conditions

	Symbol	Min.	Typ.	Max.	Unit	Remark
Input voltage	V_{CC}	4.5	5.0	5.5	V	
Permissive Power Input Ripple	V_{RF}	-	-	0.1	V	
Input Current	I_{CC}	-	0.55	0.75	A	
Differential Impedance	Z_m	90	100	110	ohm	
Power Consumption	P_C	-	2.5	3.5	Watts	
Rush Current	I_{Rush}	-	2.0	3.0	A	

b. Display color v.s. input data signals

The brightness of each primary color (red, green and blue) is based on the 8-bit gray scale data input for the color; the higher the binary input, the brighter the color. The table below provides a reference for color versus data input.

Color	Input color data																							
	Red								Green								Blue							
	MSB				LSB				MSB				LSB				MSB				LSB			
	R7	R6	R5	R4	R3	R2	R1	R0	G7	G6	G5	G4	G3	G2	G1	G0	B7	B6	B5	B4	B3	B2	B1	B0
Basic colors	Black	0	0	0	0	0	0	0	0	0	0	0	0	0	0	0	0	0	0	0	0	0	0	0
	Red(255)	1	1	1	1	1	1	1	0	0	0	0	0	0	0	0	0	0	0	0	0	0	0	0
	Green(255)	0	0	0	0	0	0	0	1	1	1	1	1	1	1	1	0	0	0	0	0	0	0	0
	Blue(255)	0	0	0	0	0	0	0	0	0	0	0	0	0	0	0	1	1	1	1	1	1	1	1
	Cyan	0	0	0	0	0	0	0	1	1	1	1	1	1	1	1	1	1	1	1	1	1	1	1
	Magenta	1	1	1	1	1	1	1	0	0	0	0	0	0	0	0	1	1	1	1	1	1	1	1
	Yellow	1	1	1	1	1	1	1	1	1	1	1	1	1	1	1	0	0	0	0	0	0	0	0
	White	1	1	1	1	1	1	1	1	1	1	1	1	1	1	1	1	1	1	1	1	1	1	1
Red	Red(000) dark	0	0	0	0	0	0	0	0	0	0	0	0	0	0	0	0	0	0	0	0	0	0	0
	Red(001)	0	0	0	0	0	0	1	0	0	0	0	0	0	0	0	0	0	0	0	0	0	0	0
	Red(002)	0	0	0	0	0	1	0	0	0	0	0	0	0	0	0	0	0	0	0	0	0	0	0
	:	:	:	:	:	:	:	:	:	:	:	:	:	:	:	:	:	:	:	:	:	:	:	:
	Red(253)	1	1	1	1	1	0	1	0	0	0	0	0	0	0	0	0	0	0	0	0	0	0	0
	Red(254)	1	1	1	1	1	1	0	0	0	0	0	0	0	0	0	0	0	0	0	0	0	0	0
	Red(255) bright	1	1	1	1	1	1	1	0	0	0	0	0	0	0	0	0	0	0	0	0	0	0	0
Green	Green(000)dark	0	0	0	0	0	0	0	0	0	0	0	0	0	0	0	0	0	0	0	0	0	0	0
	Green(001)	0	0	0	0	0	0	0	0	0	0	0	0	0	1	0	0	0	0	0	0	0	0	0
	Green(002)	0	0	0	0	0	0	0	0	0	0	0	0	1	0	0	0	0	0	0	0	0	0	0
	:	:	:	:	:	:	:	:	:	:	:	:	:	:	:	:	:	:	:	:	:	:	:	:
	Green(253)	0	0	0	0	0	0	1	1	1	1	1	1	0	1	0	0	0	0	0	0	0	0	0
	Green(254)	0	0	0	0	0	0	1	1	1	1	1	1	1	0	0	0	0	0	0	0	0	0	0
	Green(255)bright	0	0	0	0	0	0	1	1	1	1	1	1	1	1	0	0	0	0	0	0	0	0	0
Blue	Blue(000) dark	0	0	0	0	0	0	0	0	0	0	0	0	0	0	0	0	0	0	0	0	0	0	0
	Blue(001)	0	0	0	0	0	0	0	0	0	0	0	0	0	0	0	0	0	0	0	0	0	0	1
	Blue(002)	0	0	0	0	0	0	0	0	0	0	0	0	0	0	0	0	0	0	0	0	0	1	0
	:	:	:	:	:	:	:	:	:	:	:	:	:	:	:	:	:	:	:	:	:	:	:	:
	Blue(253)	0	0	0	0	0	0	0	0	0	0	0	0	0	0	1	1	1	1	1	1	1	0	1
	Blue(254)	0	0	0	0	0	0	0	0	0	0	0	0	0	0	1	1	1	1	1	1	1	1	0
	Blue(255) bright	0	0	0	0	0	0	0	0	0	0	0	0	0	0	1	1	1	1	1	1	1	1	1

SPEC NO.

PAGE 9/22

c. Input signal timing

Support Input Timing Table

	Item	Description	Min.	Typ.	Max.	Unit
Clock	Dclk	period	14.71	18.52	22.22	nS
		frequency	45	54	68	MHz
Vertical	T_{V_TOTAL}	V total line number	1044	1066	1600	T_{H_TOTAL}
	T_{V_DATA}	Data duration	—	1024	—	T_{H_TOTAL}
	T_{VB}	V-blank	20	42		T_{H_TOTAL}
	f_V	frequency	50	60	75	Hz
Horizontal	T_{H_TOTAL}	H total pixel number	710	844	1400	Clk
	T_{H_DATA}	Data duration	—	640	—	Clk
	T_{HB}	H-blank	70	204		Clk

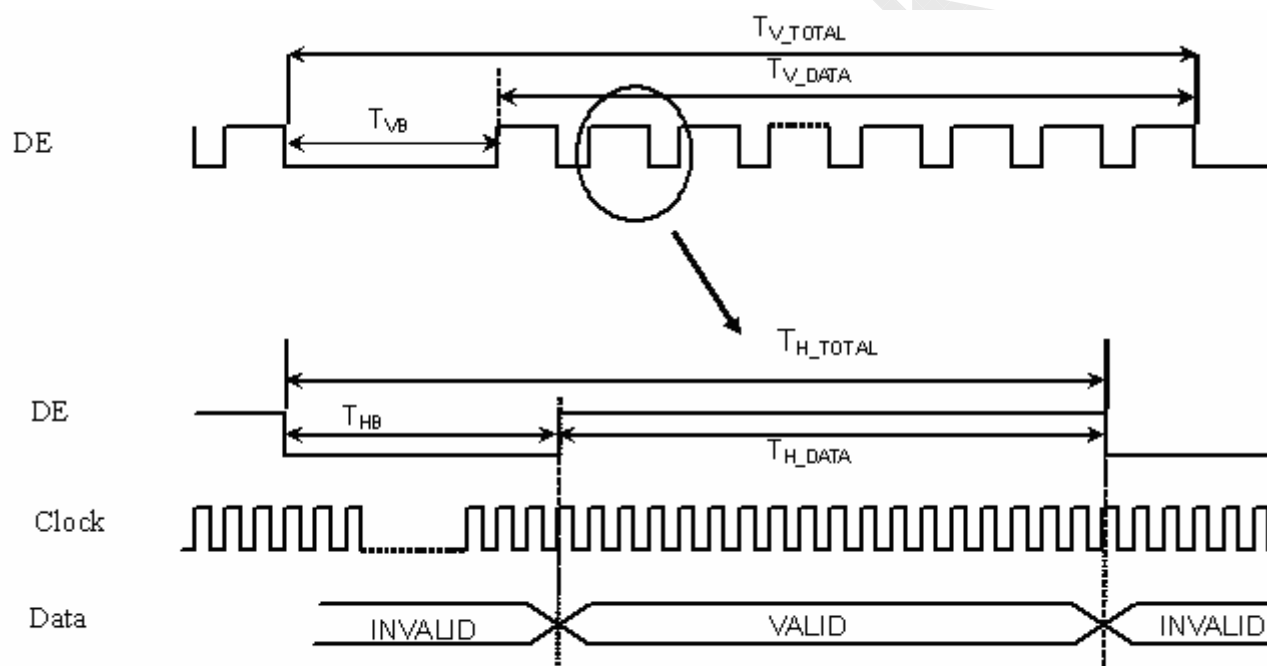

Note : DE is reference signal, DE means the display data valid.

SPEC NO.

PAGE 10/22

d. Display Position

D(1, 1)	D(2, 1)	D(640, 1)	D(1279, 1)	D(1280, 1)
D(1, 2)	D(2, 2)	D(640, 2)	D(1279, 2)	D(1280, 2)
⋮		⋮	⋮	⋮
D(1, 512)	D(2, 512)	D(640, 512)	D(1279, 512)	D(1280, 512)
⋮		⋮	⋮	⋮
D(1, 1023)	D(2, 1023)	D(640, 1023)	D(1279, 1023)	D(1280, 1023)
D(1, 1024)	D(2, 1024)	D(640, 1024)	D(1279, 1024)	D(1280, 1024)

e. Backlight driving conditions

Parameter	Symbol	Min.	Typ.	Max.	Unit	Remark
Lamp voltage	VL		610	700	Vrms	
Lamp current	IL	6.5	7	8	mArms	Note 1
Power consumption	PL		17.08	22.4	W	
Lamp starting voltage	VLstart	(1700)			Vrms	T = 25°C
		(2100)				T = 0°C
Frequency	F	40	50	80	KHZ	Note 2
Lamp life time		30000			Hr	Note 3

Note 1 :

The degrees of unbalance: less than 10%

The ratio of wave height: less than $\sqrt{2} \pm 10\%$

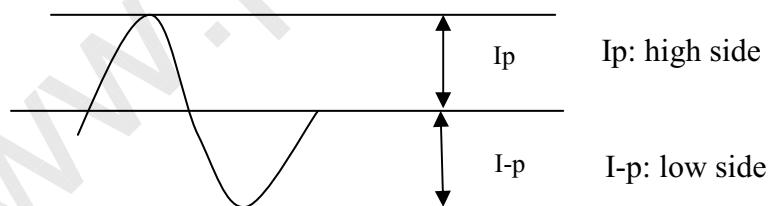

The degrees of unbalance = $|I_p - I-p| / I_{rms} * 100(\%)$

The ratio of wave height = $I_p(\text{or } I-p) / I_{rms}$

Note 2:

Lamp frequency may produce interference with horizontal synchronous frequency and this may cause line flow on the display. Therefore lamp frequency shall be detached from the horizontal synchronous frequency and its harmonics as far as possible in order to avoid interference.



SPEC NO.

PAGE 11/22

Note 3 :

Lamp life definition :

(A) Lamp current $I_L = (7) \text{ mA}$

(B) The brightness of lamp becomes 50% of the initial brightness or not normal lighting.

Backlight connector : JST BHSR - 02VS-1

Pin no.	Symbol	Function	Remark
1	VIH	Lamp high voltage input	Cable color: Pink
2	VIL	Lamp low voltage input	Cable color: White

SPEC NO.

PAGE 12/22

C. Optical specifications

Item	Symbol	Condition	Specification			Unit	Remark
			Min.	Typ.	Max.		
Response time	Tr+Tf	$\theta = 0^\circ$		16		ms	Note 4
Contrast ratio	CR	$\theta = 0^\circ$		(400)			Note 3,5
Viewing angle	Top	$CR \geq 10$		(70)		deg	Note 3,5,7
		$CR \geq 5$		(80)			
	Bottom	$CR \geq 10$		(60)			
		$CR \geq 5$		(80)			
Left	$CR \geq 10$		(70)				
	$CR \geq 5$		(80)				
Right	$CR \geq 10$		(70)				
	$CR \geq 5$		(80)				
Brightness (Center)	Y_L			(300)		nit	Note 3,6
Color chromaticity(CIE)	W_x	$\theta = 0^\circ$		(0.313)			Note 3
	W_y			(0.329)			
	R_x			(0.640)			
	R_y			(0.349)			
	G_x			(0.284)			
	G_y			(0.617)			
	B_x			(0.142)			
	B_y			(0.067)			
White uniformity (13)	δ_w		0.75	0.8			Note 3,8
Cross talk	Ct				2%		Note 9
TCO '03 A.2.3.4 (Luminance uniformity)	δ_{w2}				(1.7)		Note 10
T CO '03 A.2.4.2 (Luminance contrast)	CR_2		(0.8)				Note 11

Note 1: Ambient temperature = 25 .

Note 2: To be measured in dark room after backlight warm up 30 minutes.

Note 3: To be measured with a viewing cone of 2° by Topcon luminance meter BM-5A.

Note 4: Definition of response time:

The output signals of BM-7 are measured when the input signals are changed from “Black” to “White” (falling time) and from “White” to “Black” (rising time), respectively. The response time interval between the 10% and 90% of amplitudes. Refer to figure as below.

SPEC NO.

PAGE 13/22

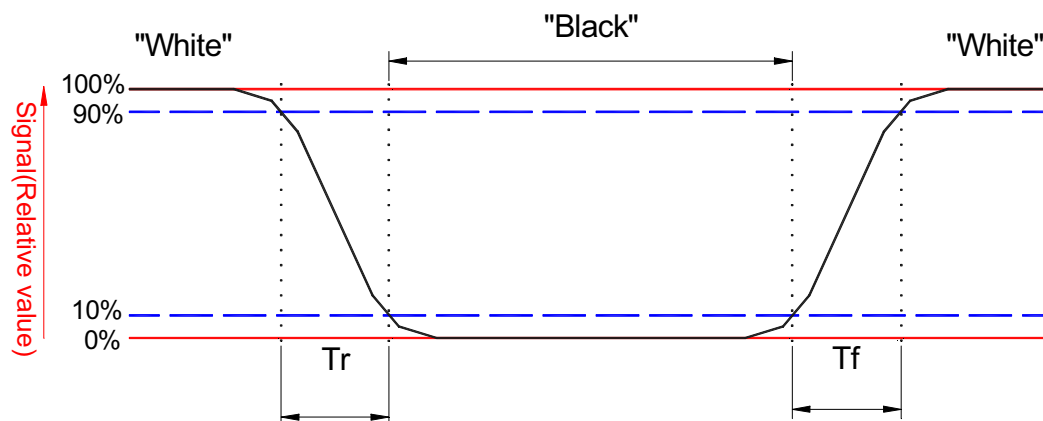

Note 5. Definition of contrast ratio:

Contrast ratio is calculated with the following formula.

$$\text{Contrast ratio (CR)} = \frac{\text{Brightness on the "white" state}}{\text{Brightness on the "black" state}}$$

Note 6: Driving conditions for CCFL: $I_L = 7.0 \text{ mA}$, 50 KHz Frequency.

Note 7: Definition of viewing angle

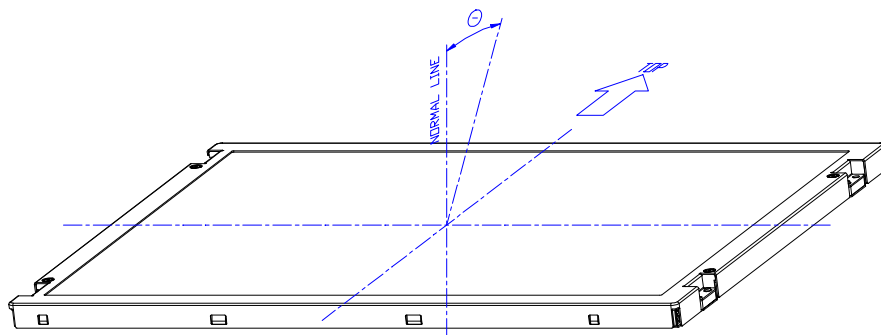

Note 8: Definition white uniformity:

Luminance are measured at the following thirteen points (1~13).

$$\delta_w = \frac{\text{Minimum Brightness of thirteen points}}{\text{Maximum Brightness of thirteen points}}$$

SPEC NO.

PAGE 14/22

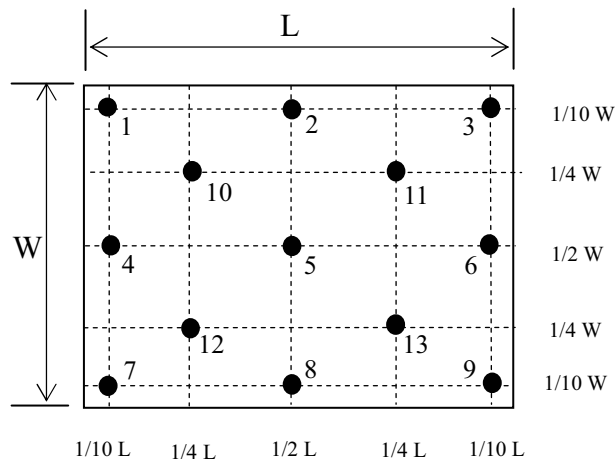

Note 9:

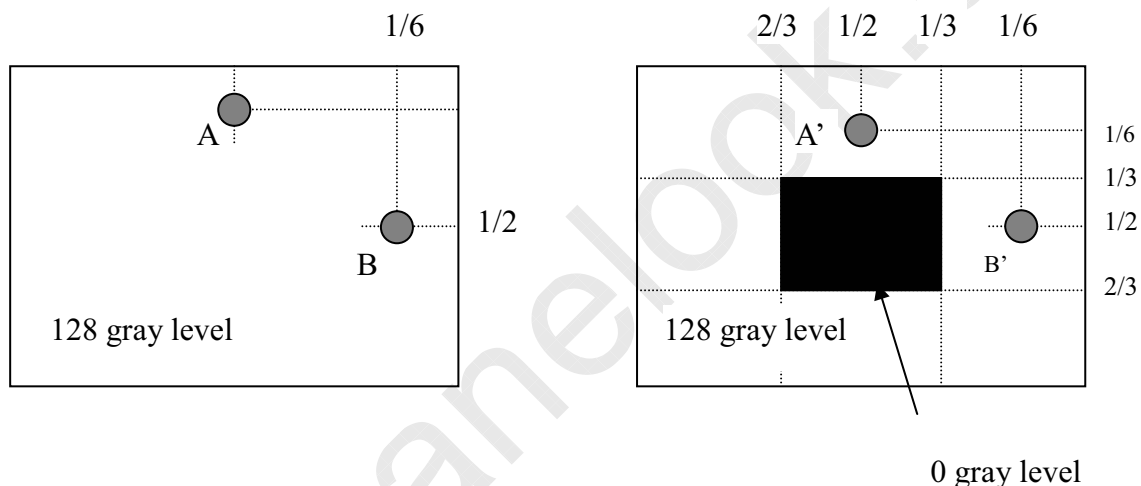

Unit: percentage of dimension of display area

$|L_A - L_{A'}| / L_A \times 100\% = 2\% \text{ max.}$, L_A and $L_{A'}$ are brightness at location A and A'

$|L_B - L_{B'}| / L_B \times 100\% = 2\% \text{ max.}$, L_B and $L_{B'}$ are brightness at location B and B'

Note 10:

TCO'03 A.2.3.4: Luminance uniformity - angular dependence.

1. Refer to Fig.1&2, for FPDs in the horizontal direction, the mean value of the Lmax. to Lmin. ratios at ± 30 degrees shall be 1.7.

$$\text{Formula: } \frac{\left(\frac{L + 30 \text{ max.}}{L + 30 \text{ min.}}\right) + \left(\frac{L - 30 \text{ max.}}{L - 30 \text{ min.}}\right)}{2} \leq 1.7$$

2. Refer to Fig.1&3, for FPDs in the vertical direction, the value of Lmax. to Lmin. ratio at +15 degree shall be 1.7 and the largest value of Lmax. to Lmin. ratio at ± 15 degree shall be

$$\text{Formula: } \frac{L + 15 \text{ max.}}{L + 15 \text{ min.}} \leq 1.7$$

SPEC NO.

PAGE 15/22

$$\text{Formula: } \text{Max.} \left(\frac{L+15 \text{ max.}}{L+15 \text{ min.}}, \frac{L-15 \text{ max.}}{L-15 \text{ min.}} \right) \leq 1.7$$

Note 11:

TCO'03 A.2.4.2: Luminance contrast – angular dependence.

Refer to Fig.1&2, center point(P_c) Luminance of White(L_w) and Black(L_B) is measured at ± 30 degrees.

The luminance contrast values C_{+30}, C_{-30} , shall be calculated using the formula:

$$C = \frac{L_w - L_B}{L_w + L_B}$$

For FPDs, Min.(C_{+30}, C_{-30}) shall be 0.8 and reported as luminance contrast.

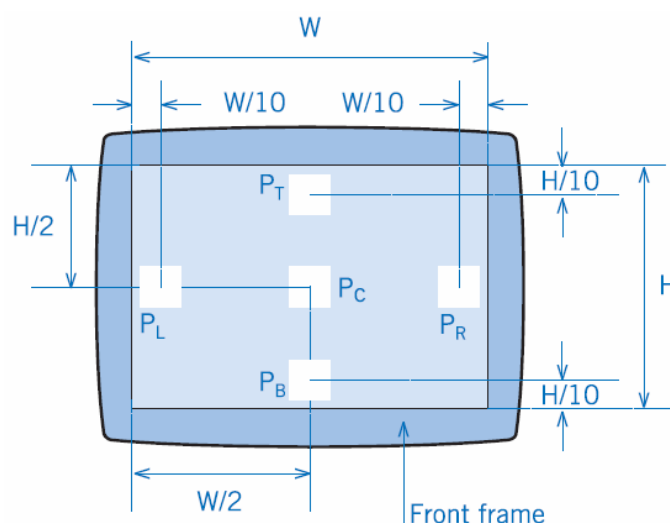

Figure1: Measurement positions for angular dependence luminance uniformity.

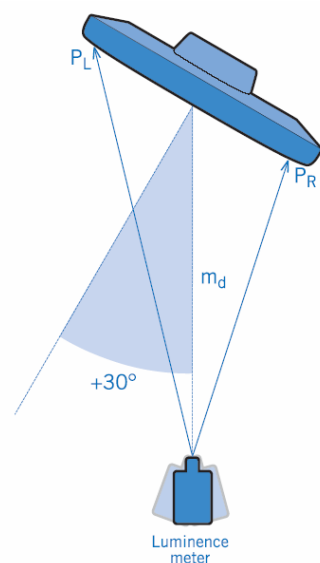

Figure2: Top view of test set-up when the screen is rotated ± 30 degrees. The +rotation is defined

ALL RIGHTS STRICTLY RESERVED. ANY PORTION OF THIS PRPER SHALL NOT BE REPRODUCED, COPIED, OR TRANSFORMED TO ANY OTHER FORMS WITHOUT PERMISSION FROM INNOLUX DISPLAY CORPORATION.



SPEC NO.

PAGE 16/22

clockwise.

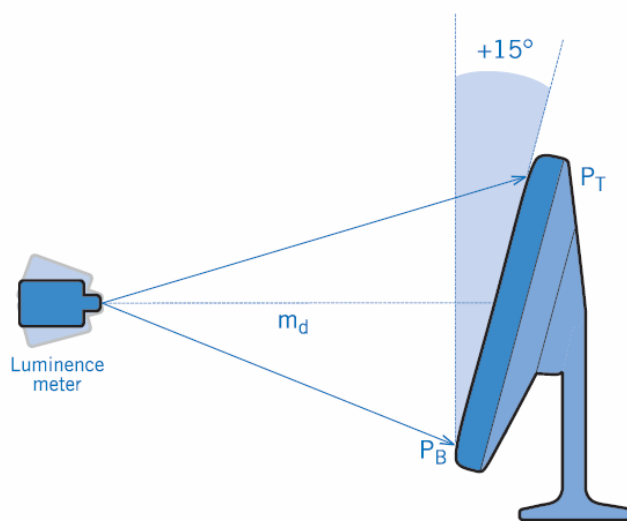

Figure3: Side view of the test set-up when the screen is tilted 15 degrees backwards.

SPEC NO.

PAGE 17/22

D. Reliability test items

Test tem	Test Condition	Judgement	Remark
High temperature storage	60 , 240Hrs	Note 1	Note 2
Low temperature storage	-20 , 240Hrs	Note 1	Note 2
High temperature & high humidity operation	40 , 90%RH, 240Hrs (No condensation)	Note 1	Note 2
High temperature operation	50 , 240Hrs	Note 1	Note 2
Low temperature operation	0 , 240Hrs	Note 1	Note 2
Temperature cycling (non-operation)	-20 ~60 1H, 10mins, 1H, 100cycles	Note 1	Note 2
Electrostatic discharge (non-operation)	150 pF,330Ω,10kV,1 second, 9 position on the panel, 10 times each place	Note 1	
Vibration (Wave) (non-operation)	Sweep:1G, 10Hz ~ 500Hz ~ 10Hz /30min 2 hours for each direction X, Y, Z (6 Hrs in total)	Note 1	Note 2
Vibration (Random) (for package) (non-operation)	0.015G2/Hz from 5~200Hz -6dB/Octave from 200~500Hz X,Y,Z three axis 2 HRS	Note 1	Note 2
Mechanical shock (non-operation)	50G/11ms, 200G/2ms, ±X, ±Y, ±Z once for each direction	Note 1	Note 2

Note 1 :

Pass: Normal display image with no obvious non-uniformity and no line defect.
Partial transformation of the module parts should be ignored.

Fail: No display image, obvious non-uniformity, or line defects.

Note 2 :

Evaluation should be tested after storage at room temperature for one hour.

SPEC NO.

PAGE 18/22

E. Safety

(1) Sharp Edge Requirements

There will be no sharp edges or corners on the display assembly that could cause injury.

(2) Materials

a. Toxicity

There will be no carcinogenic materials used anywhere in the display module. If toxic materials are used, they will be reviewed and approved by the responsible InnoLux Toxicologist.

b. Flammability

All components including electrical components that do not meet the flammability grade UL94-V1 in the module will complete the flammability rating exception approval process. The printed circuit board will be made from material rated 94-V1 or better. The actual UL flammability rating will be printed on the printed circuit board.

C. Capacitors

If any polarized capacitors are used in the display assembly, provisions will be made to keep them from being inserted backwards.

F. Display quality

The display quality of the color TFT-LCD module should be in compliance with the Innolux's Incoming inspection standard.

G. Handling precaution

The Handling of the TFT-LCD should be in compliance with the Innolux's handling principle standard.

SPEC NO.

PAGE 19/22

H. Label

(1) Module Label

83 mm

23 mm

MT170EN01

V. x

保留空間,預放置
安規代號

INNOLUX
DISPLAY

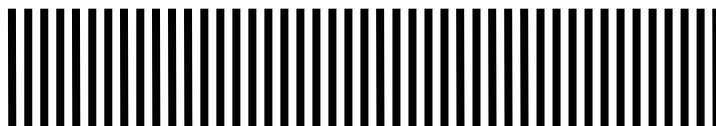

Z₁ Z₂ Z₃ Z₄ -Z₅ Z₆ Z₇ -Z₈ Z₉ Z₁₀ Z₁₁ Z₁₂

MADE IN CHINA

INNOLUX DISPLAY

BOX ID:



100 mm

□ □ □ □ □ □ □ □ □
Y₁ Y₂ Y₃ Y₄ Y₅ Y₆ Y₇ Y₈ Y₉

Model No. MT170EN01 V.0

AM17000500

Quantity : 5 PCS

MFG Date: 20XX/XX/XX

Made in China

120 mm



SPEC NO.

PAGE 20/22

I. Packing form

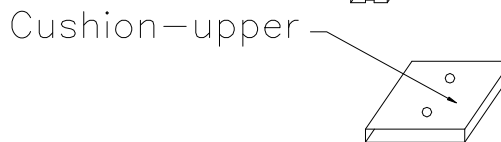

↓ Step A
Put LCM into A/S bag

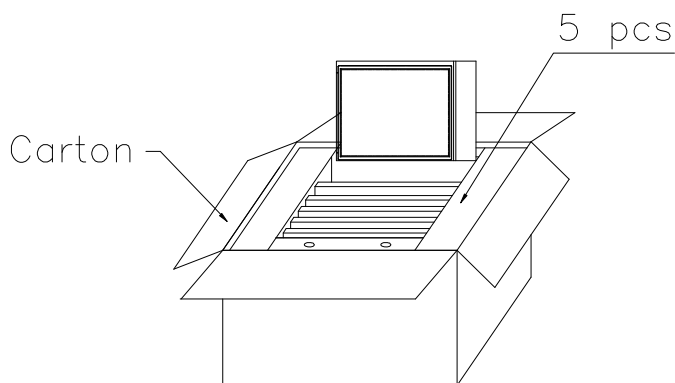
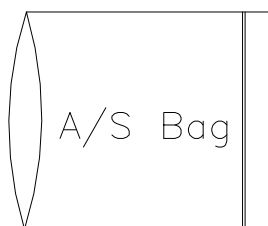

↓ Step B
Turn back A/S bag

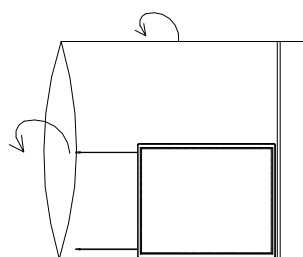

→ Step C

↓ Step F

↓ Step C

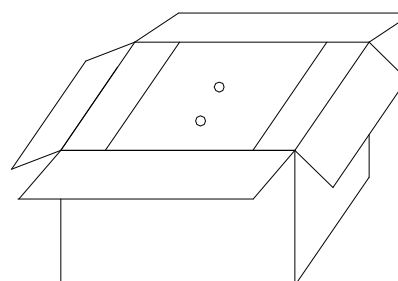

Step D
Put LCM with A/S bag into carton

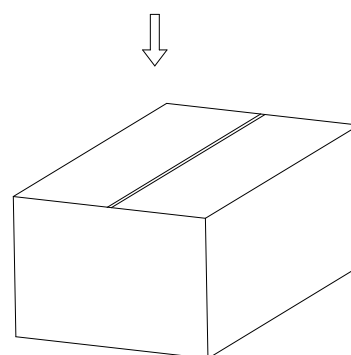

SPEC NO. PAGE 21/22

J. ME Drawing (1) Front view

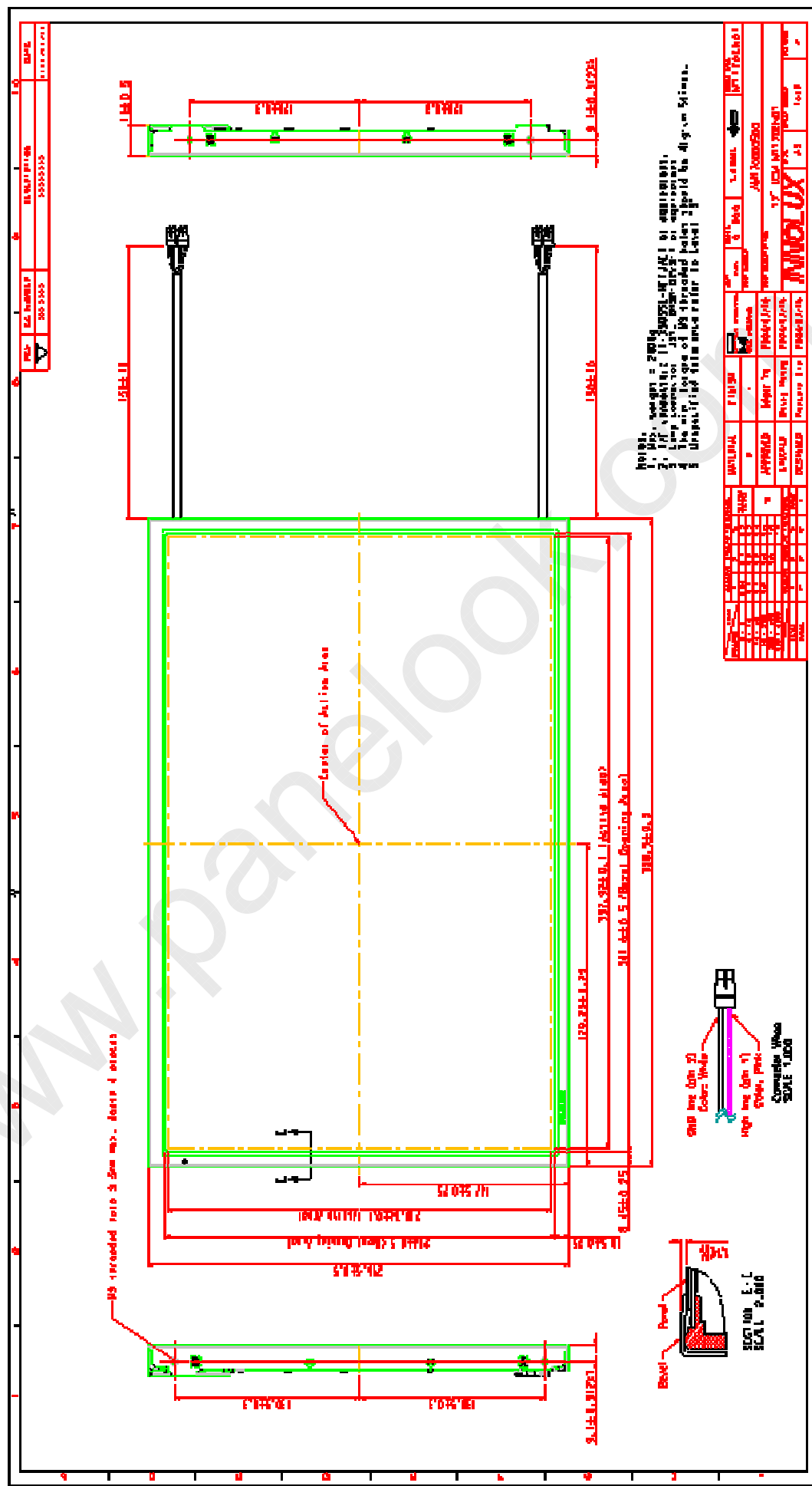

ALL RIGHTS STRICTLY RESERVED. ANY PORTION OF THIS PRPER SHALL NOT BE REPRODUCED, COPIED, OR TRANSFORMED TO ANY OTHER FORMS WITHOUT PERMISSION FROM INNOLUX DISPLAY CORPORATION.

SPEC NO. :

PAGE : 23/23

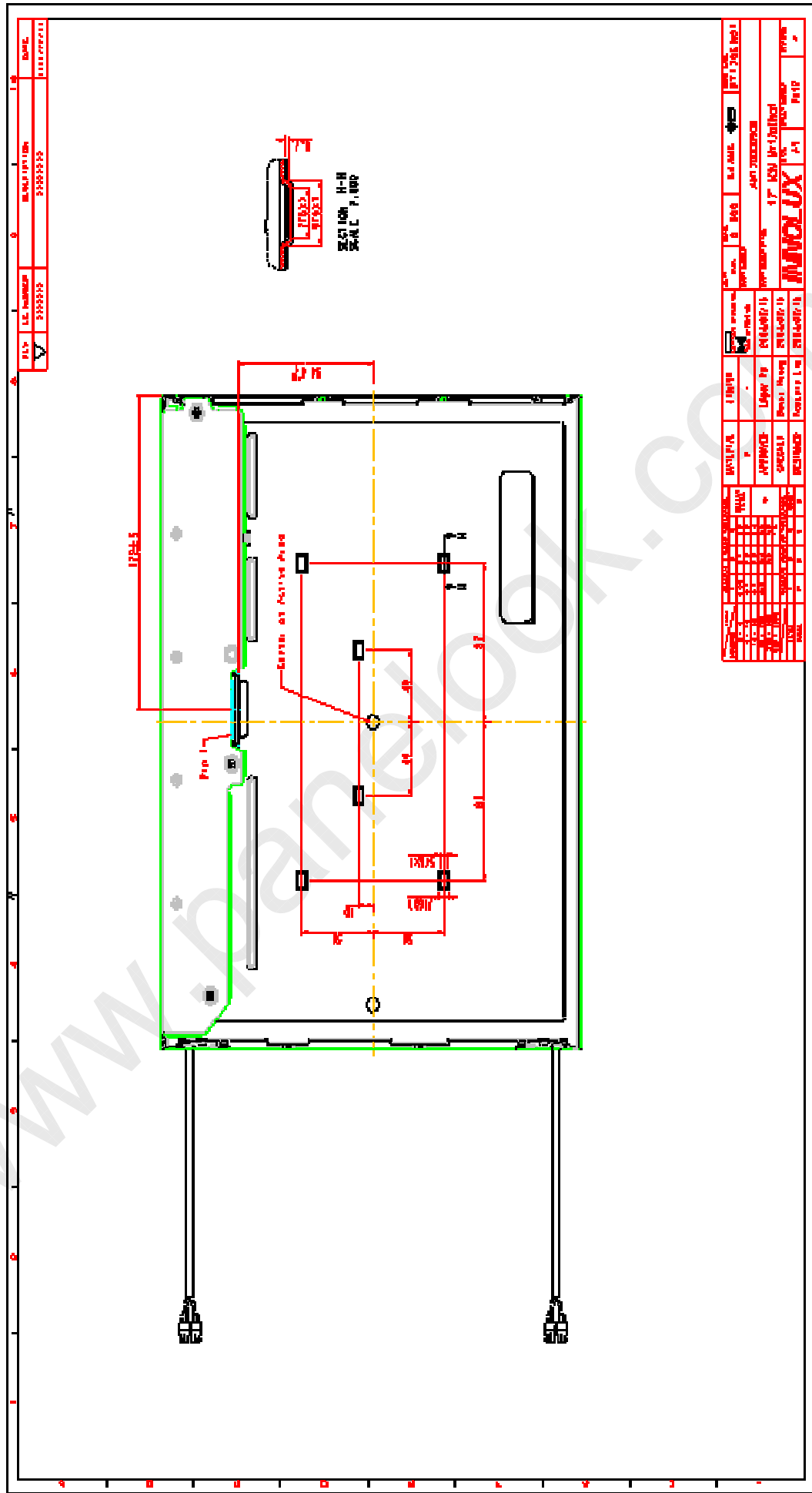
(2) Back view

ALL RIGHTS STRICTLY RESERVED. ANY PORTION OF THIS PRPER SHALL NOT BE REPRODUCED, COPIED, OR TRANSFORMED TO ANY OTHER FORMS WITHOUT PERMISSION FROM INNOLUX DISPLAY CORPORATION.