

INNOLUX DISPLAY CORPORATION

MT190AW02 V.3 LCD MODULE SPECIFICATION

() Preliminary Specification

(●) Final Specification

<i>Approved by</i>	<i>Checked by</i>	<i>Prepared by</i>

Innolux Display Corporation,

No.160 Kesyue Rd., Chu-Nan Site, Hsinchu Science Park,

Chu-Nan 350, Miao-Li County, Taiwan

Tel: 886-37-586000

Fax: 886-37-586060

Document Number: MT190AW02 V.3 -DR4-26



INNOLUX DISPLAY CORPORATION

MT190AW02 V.3 LCD MODULE SPECIFICATION

Department		Prepared by	Checked by
MKT			
PD	EE		
	ME		
TD			
RA			

Innolux Display Corporation

Document Number: MT190AW02 V.3 -DR4-26

SPEC NO. MT190AW02 V.3

PAGE 3/24

Version:2.0

InnoLux copyright
All rights reserved,
Copying forbidden.

Record of Revision

Versi	Revise	Pag	Content
1.0	2009/03/11	All	First edition to all Pre-Spec.
2.0	2009/05/7	5	Update weight from 2200 (typ) to 2200 (max)
			Update Color saturation from TBD to 68% (typ)
	2009/05/8	16	Update Color chromaticity
			From Rx (typ) TBD to 0.6390
			From Ry (typ) TBD to 0.3457
			From Gx (typ) TBD to 0.3233
			From Gy (typ) TBD to 0.6202
			From Bx (typ) TBD to 0.1491
			From By (typ) TBD to 0.0599
		16	Update Brightness from 220(Min.) to 200(Min.)
		16	Update White Uniformity(9) from TBD 0.70(Min.)
		23	Update ME front view
		24	Update ME back view
	2009/06/4	7	FFC Cancellation

SPEC NO. MT190AW02 V.3

PAGE 4/24

Contents:	
A. General Specification	
B. Electrical Specifications	
1. Pin assignment	
2. Absolute maximum ratings	
3. Electrical characteristics	
a. Typical operating conditions	
b. Display color vs. input data signals	
c. Input signal timing	
d. Display position	
e. Backlight Unit	
C. Optical specifications	
D. Reliability test items	
E. Safety	
F. Display quality	
G. Handling precaution	
H. Label	
I. Mechanical drawings	
Appendix	

A. General specification

NO.	Item	Specification	Remark
1	Display resolution (pixel)	1,440(H) X 900(V)	
2	Active area (mm)	408.24(H) X 255.15(V)	
3	Screen size (inch)	19 inches diagonal	
4	Pixel pitch (mm)	0.2835(H) X 0.2835(V)	
5	Color configuration	R, G, B vertical stripe	
6	Overall dimension (mm)	428 (W) X 278 (H) X 16 (D) (Typ.)	
7	Weight (g)	2200 (Max.)	
8	Surface treatment	Anti-Glare, Haze=25%, Hard coating (3H)	Note 1
9	Input color signal	8 bit LVDS	
10	Display colors	16.7M (6 bit with Hi-FRC)	
11	Optimum viewing direction	6 o'clock	
12	Backlight	Side-light bar (White LED)	
13	Color saturation	68% NTSC	
14	RoHS & TCO'03 & HF	RoHS & TCO'03 & HF compliance	Note 2

Note 1: Glare Option available

Note 2: Only Anti-Glare model can meet TCO'03 compliance

B. Electrical specifications

1. Pin assignment

Connector

FOXCONN GS23302-0311S-7F or mechanical interface equivalent connector.

Pin No	Symbol	Description
Frame	VSS	Ground
1	RXinO0-	-LVDS differential data input, Chan 0-Odd
2	RXinO0+	+LVDS differential data input, Chan 0-Odd
3	RXinO1-	-LVDS differential data input, Chan 1-Odd
4	RXinO1+	+LVDS differential data input, Chan 1-Odd
5	RXinO2-	-LVDS differential data input, Chan 2-Odd
6	RXinO2+	+LVDS differential data input, Chan 2-Odd
7	VSS	Ground
8	RXOC-	-LVDS differential Clock input (Odd)
9	RXOC+	+LVDS differential Clock input (Odd)
10	RXinO3-	-LVDS differential data input, Chan 3-Odd
11	RXinO3+	+LVDS differential data input, Chan 3-Odd
12	RXinE0-	-LVDS differential data input, Chan 0-Even
13	RXinE0+	+LVDS differential data input, Chan 0-Even
14	VSS	Ground
15	RXinE1-	-LVDS differential data input, Chan 1-Even
16	RXinE1+	+LVDS differential data input, Chan 1-Even
17	VSS	Ground
18	RXinE2-	-LVDS differential data input, Chan 2-Even
19	RXinE2+	+LVDS differential data input, Chan 2-Even
20	RXEC-	-LVDS differential Clock input (Even)
21	RXEC+	+LVDS differential Clock input (Even)
22	RXinE3-	-LVDS differential data input, Chan 3-Even
23	RXinE3+	+LVDS differential data input, Chan 3-Even
24	VSS	Ground
25	NC	No Connection
26	NC	No Connection
27	NC	No Connection
28	VCC	+5.0V power supply
29	VCC	+5.0V power supply
30	VCC	+5.0V power supply
Frame	VSS	Ground

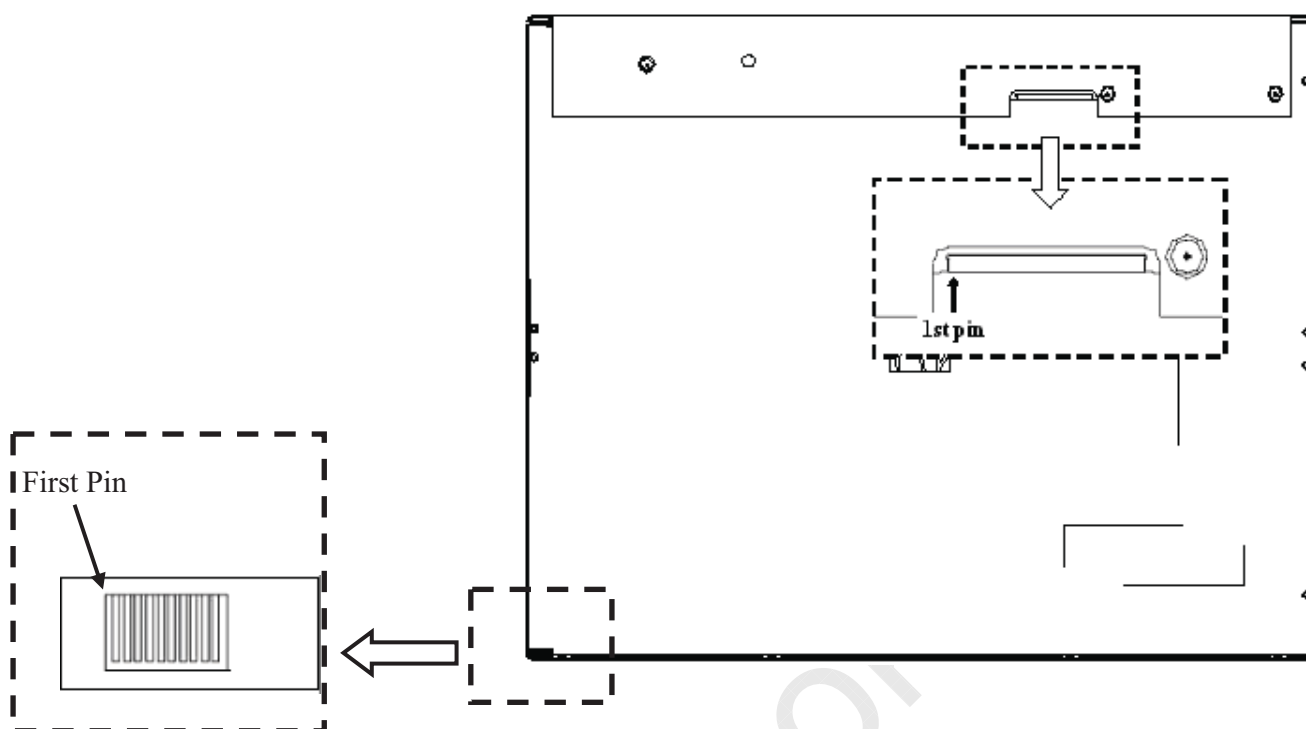

1.2 LED Light Bar

Pin No	Symbol	Description
1	NC	No Connection
2	IRLED3	LED current sense for string3
3	IRLED1	LED current sense for string1
4	VLED	LED power supply
5	VLED	LED power supply
6	VLED	LED power supply
7	VLED	LED power supply
8	IRLED5	LED current sense for string5
9	IRLED4	LED current sense for string4
10	IRLED2	LED current sense for string2

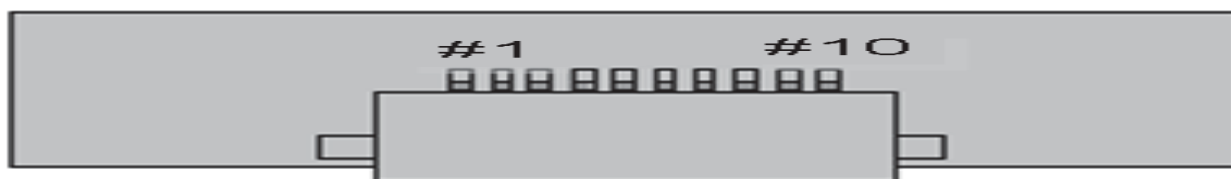

Top view of LED Light Bar connector



Rear view of LED Light Bar LVDS connector

2. Absolute maximum ratings

Parameter	Symbol	Values			Unit	Remark
		Min.	Typ.	Max.		
Power voltage	V _{CC}	-0.3	-	6.0	V	At 25°C
Input signal voltage	V _{LH}	-0.3	-	4.3	V	At 25°C
Operating	Top	0	-	50	°C	Note 1
Storage temperature	T _{ST}	-20	-	60	°C	Note 2

Note 1: The relative humidity must not exceed 90% non-condensing at temperatures of 40°C or less. At temperatures greater than 40°C, the wet bulb temperature must not exceed 39°C.

Note 2: The unit should not be exposed to corrosive chemicals.

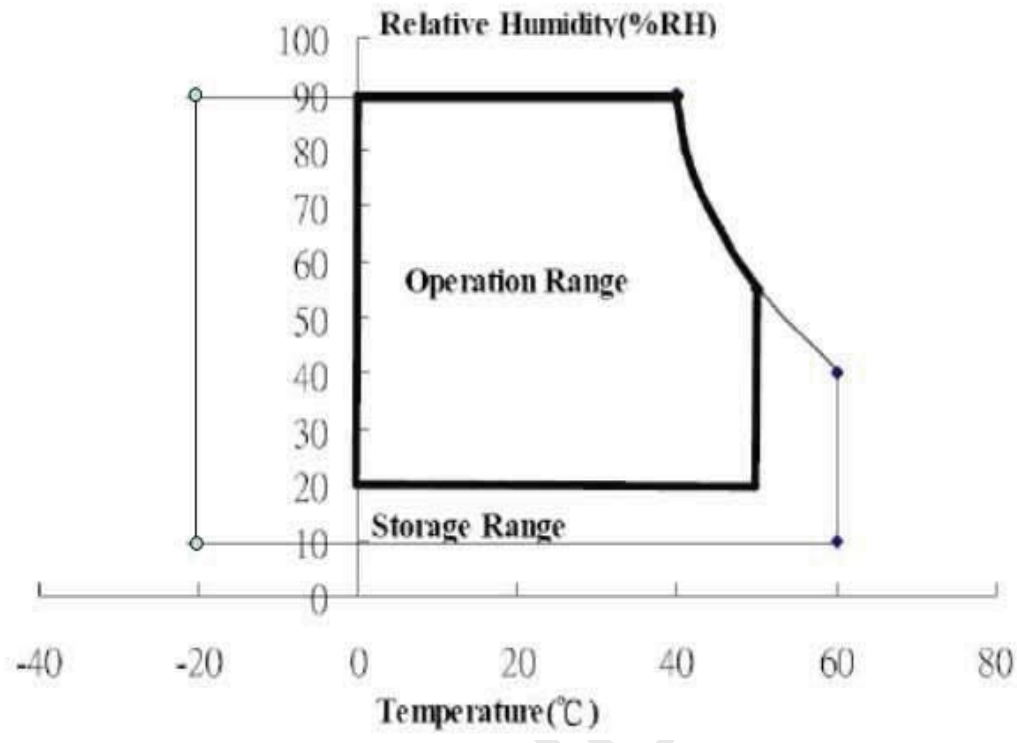

www.panelook.com

3. Electrical characteristics

a. Typical operating conditions

Item		Symbol	Min.	Typ.	Max.	Unit	Remar
Input Voltage		V_{CC}	4.5	5	5.5	V	
Permissive Power Input Ripple		V_{RF}	-	-	0.15	v	
Input Current	Black	I_{CC}	-	700	1000	mA	Note 1
	White	I_{CC}	-	500	700		Note 2
	Mosaic	I_{CC}	-	700	1000		Note 3
Rush Current		I_{Rush}	-	1.6	3	A	Note 4
Logic Input Voltage LVDS: IN+, IN-	Common Mode	VCM	-	1.2	-	V	
	Differential Input	VID	100	-	600	mV	
	Threshold Voltage	VTH	-	-	100	mV	Note 5
	Threshold Voltage	VTL	-100	-	-	mV	Note 5

Note 1 : The specified current is under the $V_{CC} = 5V$, $25^{\circ}C$, $f_v = 60Hz$ (frame frequency) condition whereas black pattern is displayed.

Note 2 : The specified current is under the $V_{CC} = 5V$, $25^{\circ}C$, $f_v = 60Hz$ (frame frequency) condition whereas white pattern is displayed.

Note 3 : The specified current is under the $V_{CC} = 5V$, $25^{\circ}C$, $f_v = 60Hz$ (frame frequency) condition whereas mosaic pattern (black & white [8*6]) is displayed.

White : 255 Gray

Black : 0 Gray

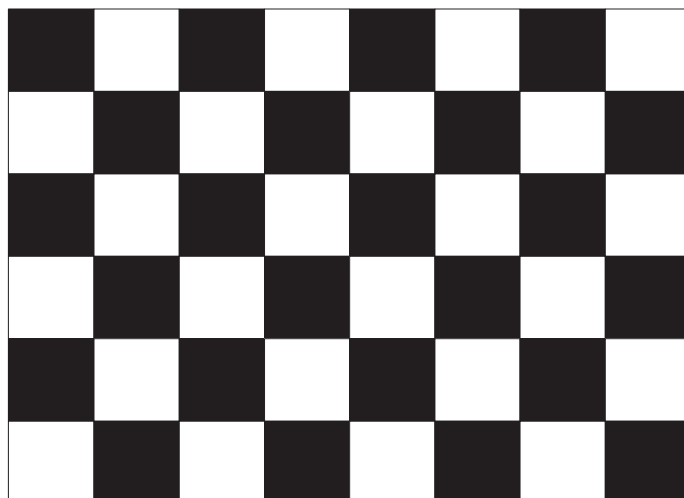

Note 4 : test condition :

- (1) $V_{DD} = 5\text{ V}$, V_{DD} rising time = $470\ \mu\text{s} \pm 10\%$
- (2) Pattern: Mosaic pattern

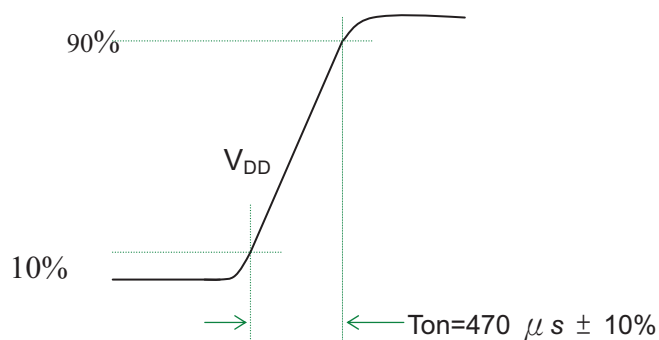

(3) Test circuit

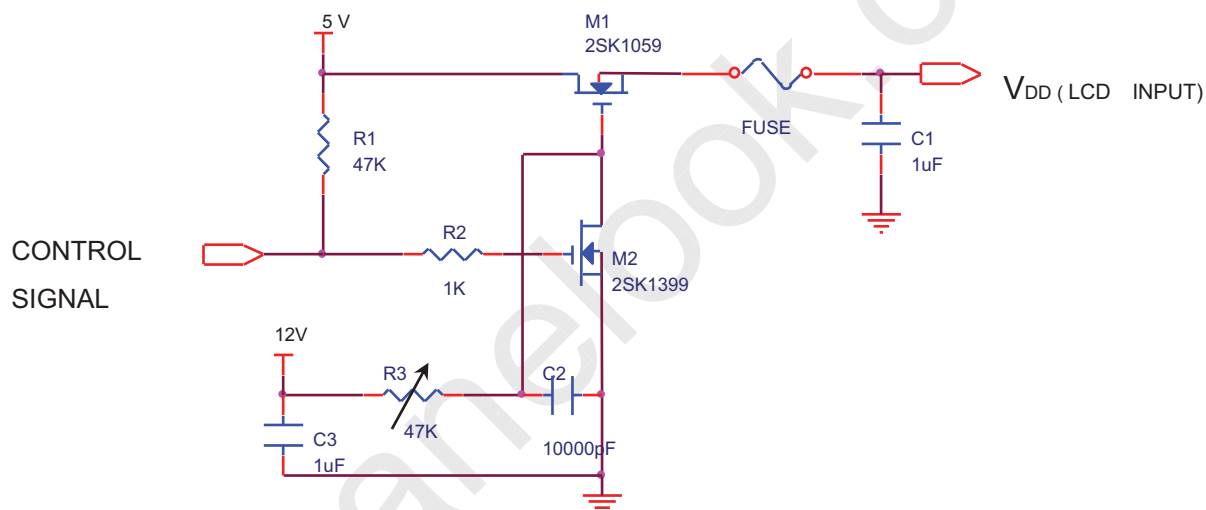

Note 5: LVDS signal definition

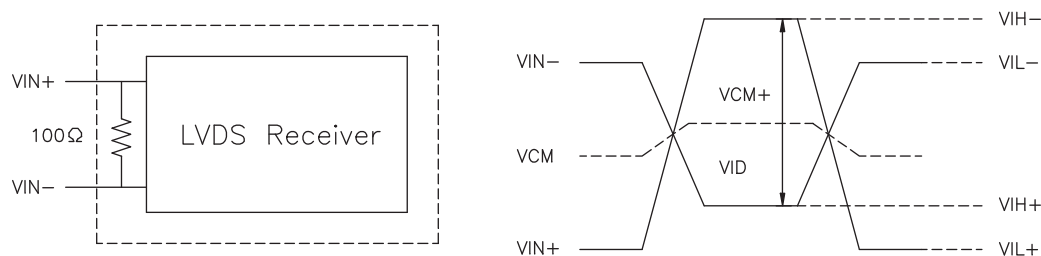

$VIN+$ = Positive differential DATA & CLK Input

$VIN-$ = Negative differential DATA & CLK Input

$$\Delta V_{CM} = |V_{CM+} - V_{CM-}|,$$

$$\Delta V_{ID} = |V_{ID+} - V_{ID-}|,$$

$$V_{ID+} = |V_{IH+} - V_{IH-}|,$$

$$V_{ID-} = |V_{IL+} - V_{IL-}|,$$

$$V_{CM} = (V_{IN+} + V_{IN-})/2,$$

$$V_{CM+} = (V_{IH+} + V_{IH-})/2,$$

$$V_{CM-} = (V_{IL+} + V_{IL-})/2,$$

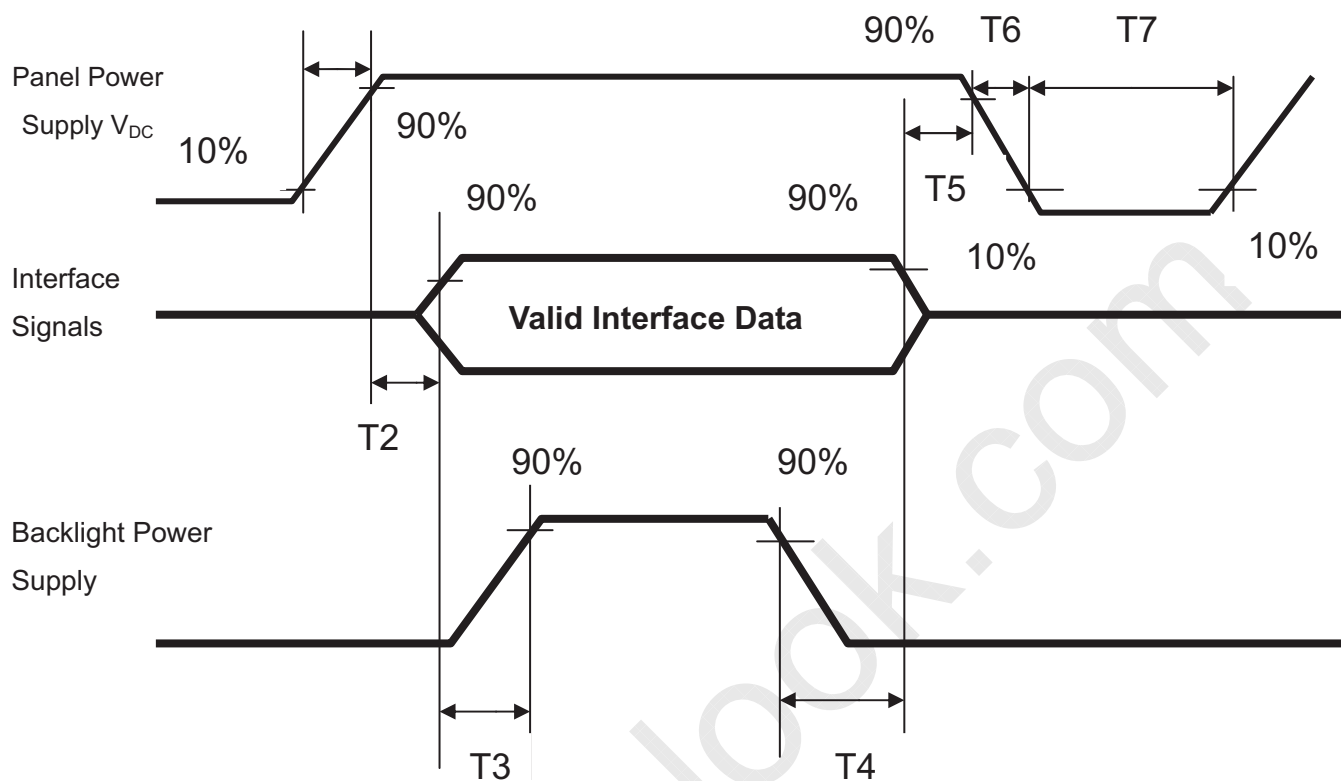
P.S. : Power on sequence for LCD V_{DD} 

Parameter	Value			Unit
	Min	Typ	Max	
T1	0.1	-	10	ms
T2	0	30	50	ms
T3	200	250	-	ms
T4	100	250	-	ms
T5	0	20	50	ms
T6	0.1	-	10	ms
T7	1000	-	-	ms

b. Display color vs. input data signals

The brightness of each primary color (red, green and blue) is based on the 8-bit gray scale data input for the color; the higher the binary input, the brighter the color. The table below provides a reference for color versus data input.

Color	Input color data																							
	Red								Green								Blue							
	MSB				LSB				MSB				LSB				MSB				LSB			
	R7	R6	R5	R4	R3	R2	R1	R0	G7	G6	G5	G4	G3	G2	G1	G0	B7	B6	B5	B4	B3	B2	B1	B0
Basic colors	Black	0	0	0	0	0	0	0	0	0	0	0	0	0	0	0	0	0	0	0	0	0	0	0
	Red(255)	1	1	1	1	1	1	1	0	0	0	0	0	0	0	0	0	0	0	0	0	0	0	0
	Green(255)	0	0	0	0	0	0	0	0	1	1	1	1	1	1	1	0	0	0	0	0	0	0	0
	Blue(255)	0	0	0	0	0	0	0	0	0	0	0	0	0	0	0	1	1	1	1	1	1	1	1
	Cyan	0	0	0	0	0	0	0	0	1	1	1	1	1	1	1	1	1	1	1	1	1	1	1
	Magenta	1	1	1	1	1	1	1	1	0	0	0	0	0	0	0	0	1	1	1	1	1	1	1
	Yellow	1	1	1	1	1	1	1	1	1	1	1	1	1	1	1	0	0	0	0	0	0	0	0
	White	1	1	1	1	1	1	1	1	1	1	1	1	1	1	1	1	1	1	1	1	1	1	1
Red	Red(000) dark	0	0	0	0	0	0	0	0	0	0	0	0	0	0	0	0	0	0	0	0	0	0	
	Red(001)	0	0	0	0	0	0	0	1	0	0	0	0	0	0	0	0	0	0	0	0	0	0	
	Red(002)	0	0	0	0	0	0	1	0	0	0	0	0	0	0	0	0	0	0	0	0	0	0	
	:	:	:	:	:	:	:	:	:	:	:	:	:	:	:	:	:	:	:	:	:	:	:	
	Red(253)	1	1	1	1	1	1	0	1	0	0	0	0	0	0	0	0	0	0	0	0	0	0	
	Red(254)	1	1	1	1	1	1	1	0	0	0	0	0	0	0	0	0	0	0	0	0	0	0	
	Red(255) bright	1	1	1	1	1	1	1	1	0	0	0	0	0	0	0	0	0	0	0	0	0	0	
Green	Green(000)dark	0	0	0	0	0	0	0	0	0	0	0	0	0	0	0	0	0	0	0	0	0	0	
	Green(001)	0	0	0	0	0	0	0	0	0	0	0	0	0	0	1	0	0	0	0	0	0	0	
	Green(002)	0	0	0	0	0	0	0	0	0	0	0	0	0	1	0	0	0	0	0	0	0	0	
	:	:	:	:	:	:	:	:	:	:	:	:	:	:	:	:	:	:	:	:	:	:	:	
	Green(253)	0	0	0	0	0	0	0	0	1	1	1	1	1	1	0	1	0	0	0	0	0	0	
	Green(254)	0	0	0	0	0	0	0	0	1	1	1	1	1	1	0	0	0	0	0	0	0	0	
	Green(255)bright	0	0	0	0	0	0	0	0	1	1	1	1	1	1	1	0	0	0	0	0	0	0	
Blue	Blue(000) dark	0	0	0	0	0	0	0	0	0	0	0	0	0	0	0	0	0	0	0	0	0	0	
	Blue(001)	0	0	0	0	0	0	0	0	0	0	0	0	0	0	0	0	0	0	0	0	0	1	
	Blue(002)	0	0	0	0	0	0	0	0	0	0	0	0	0	0	0	0	0	0	0	0	0	1	
	:	:	:	:	:	:	:	:	:	:	:	:	:	:	:	:	:	:	:	:	:	:	:	
	Blue(253)	0	0	0	0	0	0	0	0	0	0	0	0	0	0	0	1	1	1	1	1	1	0	
	Blue(254)	0	0	0	0	0	0	0	0	0	0	0	0	0	0	0	1	1	1	1	1	1	0	
	Blue(255) bright	0	0	0	0	0	0	0	0	0	0	0	0	0	0	0	1	1	1	1	1	1	1	

c. Input signal timing

Support Input Timing Table

	Item	Description	Min.	Typ.	Max.	Unit
Clock	Dclk	period	17.24	22.5	27	nS
		frequency	37	44.4	58	MHz
Vertical	T_{V_TOTAL}	V total line number	905	926	942	T_{H_TOTAL}
	T_{V_DATA}	Data duration	—	900	—	T_{H_TOTAL}
	T_{VB}	V-blank	5	26	—	T_{H_TOTAL}
	f_V	frequency	50	60	75	Hz
Horizontal	T_{H_TOTAL}	H total pixel number	752	800	968	DCIk
	T_{H_DATA}	Data duration	—	720	—	DCIk
	T_{HB}	H-blank	32	80	—	DCIk

Note: Because this module is operated by DE only mode, Hsync and Vsync input signals should be set to low Logic level or ground. Otherwise, this module would operate abnormally.

INPUT SIGNAL TIMING DIAGRAM

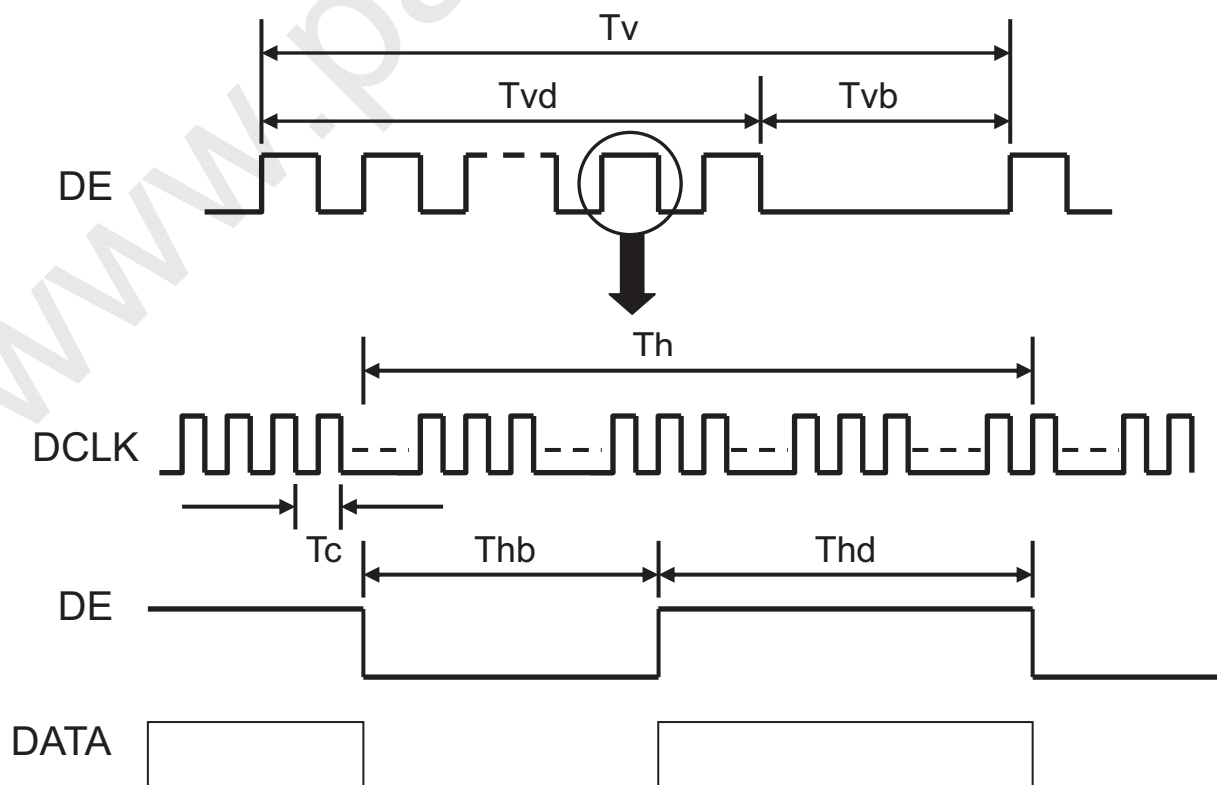

d. Display Position

D(1, 1)	D(2, 1)	D(720, 1)	D(1439, 1)	D(1440, 1)
D(1, 2)	D(2, 2)	D(720, 2)	D(1439, 2)	D(1440, 2)
⋮		⋮	⋮	⋮
D(1, 450)	D(2, 450)	D(720, 450)	D(1439, 450)	D(1440, 450)
⋮		⋮	⋮	⋮
D(1, 899)	D(2, 899)	D(720, 899)	D(1439, 899)	D(1440, 899)
D(1, 900)	D(2, 900)	D(720, 900)	D(1439, 900)	D(1440, 900)

e. Backlight Unit

Parameter	Symbol	Value			Unit	Note
		Min.	Typ.	Max.		
Light Bar Input Voltage	V_{LED}	---	---	42	V_{DC}	(Duty 100%)
Light Bar Input Current	I_{LED}	---	---	200	mA_{DC}	(1),(2),(3)
Power Consumption	P_{LED}	---	---	7.92	W	(4)
LED Life Time	L_{BL}	---	30000	---	Hrs	(5)

Note (1): There are one Light Bar, and the specified current is input LED chip 100% duty current.

Note (2): The sensing current of each string is 40mA.

Note (3): The light bar have five current sensing strings, so that the light bar input current is 200mA.

Note (4): $P_{LED} = I_{LED} \times V_{LED}$.

Note (5): The life time is determined as the time at which luminance of the LED becomes 50% of the initial brightness or not normal lighting at $I_{LED}=200mA$ on condition of continuous operating at $25\pm 2^{\circ}C$.

C. Optical specifications

Item	Symbol	Condition	Specification			Unit	Remark
			Min.	Typ.	Max.		
Response time	Tr	$\theta = 0^\circ$	-	1.5	4	ms	Note 4
	Tf		-	3.5	6		
	Tr+Tf		-	5	10		
Contrast ratio	CR	$\theta = 0^\circ$	700	1000	-		Note 3,5
Viewing angle	Top	$CR \geq 10$	70	80	-	deg.	Note 3,5,6
	Bottom	$CR \geq 10$	70	80	-		
	Left	$CR \geq 10$	75	85	-		
	Right	$CR \geq 10$	75	85	-		
Brightness (Center)	YL		200	250	-	Nits	Note 3
Color chromaticity(CIE)	Wx	$\theta = 0^\circ$	-0.03	0.3130	+0.03		Note 3
	Wy			0.3290			
	Rx			0.6390			
	Ry			0.3457			
	Gx			0.3233			
	Gy			0.6202			
	Bx			0.1491			
	By			0.0599			
White uniformity (9)	δW		0.70	0.75	-		Note
Cross talk	Ct		-	-	2%		Note8

Note 1: Ambient temperature = 25°C.

Note 2: To be measured in dark room after backlight warm up 10 minutes.

Note 3: To be measured with a viewing cone of 2° by Topcon luminance meter BM-5A.

Note 4: Definition of response time:

The output signals of BM-7 are measured when the input signals are changed from "Black" to "White" (falling time) and from "White" to "Black" (rising time), respectively. The response time interval is between the 10% and 90% of amplitudes. Refer to figure as below.

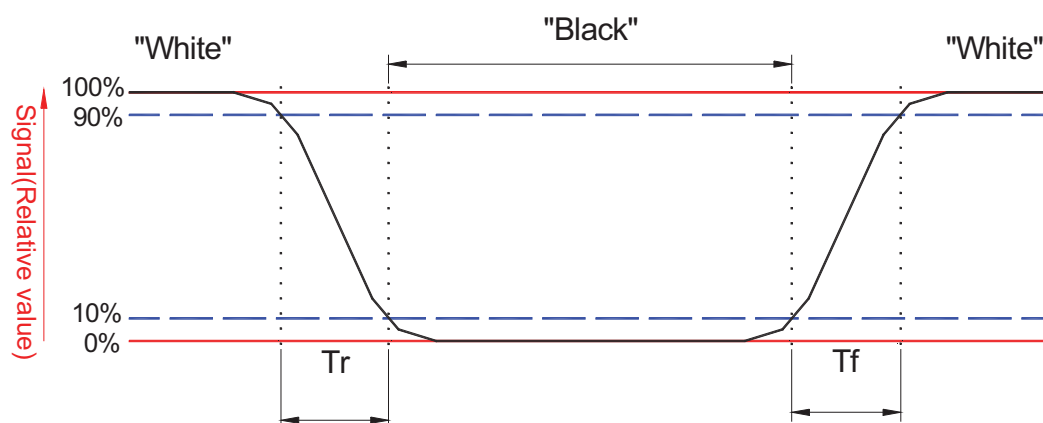

Note 5: Definition of contrast ratio:

Contrast ratio is calculated by the following formula.

$$\text{Contrast ratio (CR)} = \frac{\text{Brightness on the "white" state}}{\text{Brightness on the "black" state}}$$

Note6: Definition of viewing angle

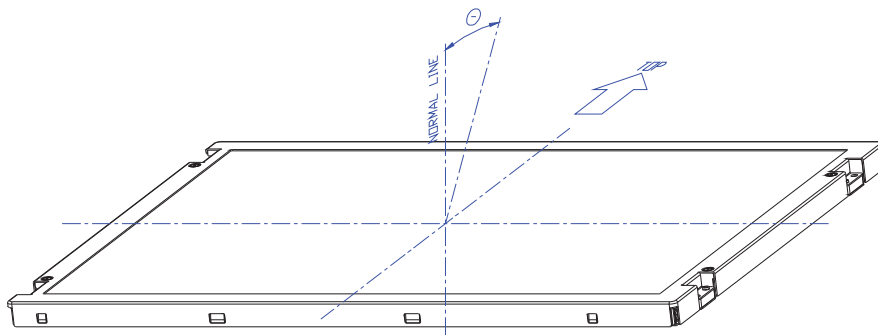

Note7: Definition white uniformity:

Luminance are measured at the following nine points (P1~P9).

$$\delta_w = \frac{\text{Minimum Brightness of nine points (P1~P9)}}{\text{Maximum Brightness of nine points (P1~P9)}}$$

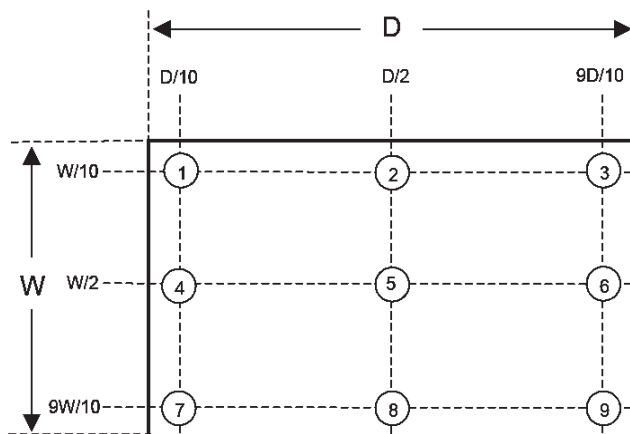

Note8:

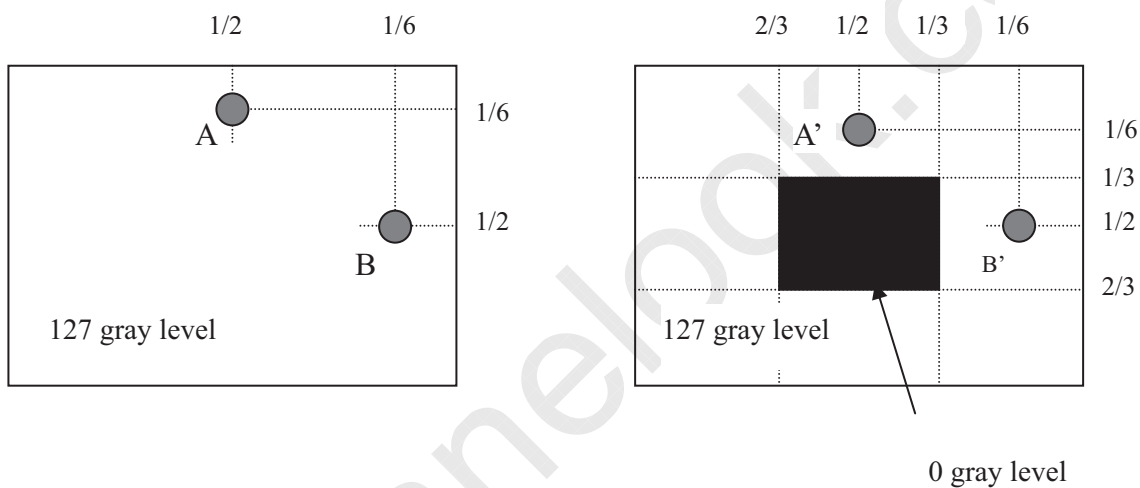

$|LA - LA'| / LA \times 100\% = 2\% \text{ max.}$, LA and LA' are brightness at location A and A'
 $|LB - LB'| / LB \times 100\% = 2\% \text{ max.}$, LB and LB' are brightness at location B and B'
 Note9: Optical characteristic measurement setup.

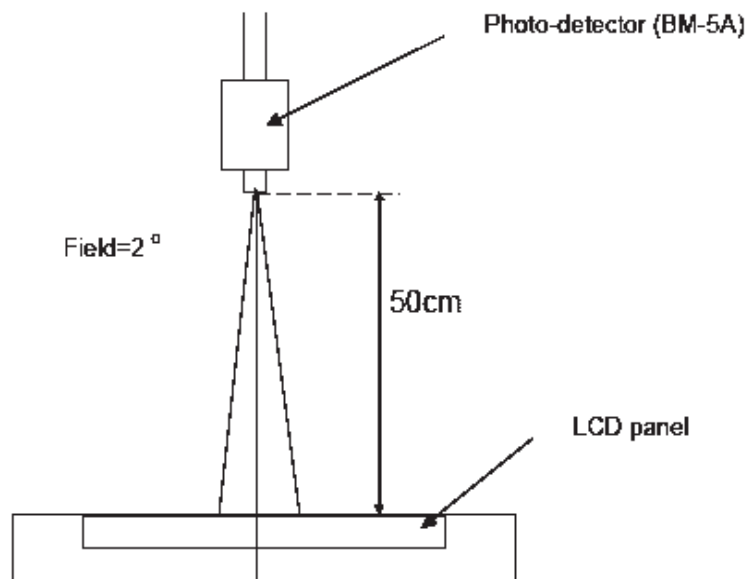

D. Reliability test items

Test Item	Test Condition	Judgment	Remar
High temperature storage	60°C, 240Hrs	Note 1	Note 2
Low temperature storage	-20°C, 240Hrs	Note 1	Note 2
High temperature & high humidity operation	40°C, 90%RH, 240Hrs (No condensation)	Note 1	Note 2
High temperature	50°C, 240Hrs	Note 1	Note 2
Low temperature operation	0°C, 240Hrs	Note 1	Note 2
Thermal Shock (non-operation)	-20°C~60°C 1Hr, 1Hr, 100cycles	Note 1	Note 2
Electrostatic discharge (ESD)	Contact: +/-8kV, 150pF(330ohms), 16points 10 times/1 point, 1 time/1 sec Air discharge: +/-15kV, 150pF(330ohms), 9 points, 10 times/1 point, 1 time/1 sec	Note 1	Note 2
Vibration (non-operation)	Vibration level : 1.5G Bandwidth : 10-300Hz Waveform : sine wave, sweep rate : 10min 30 min for each direction X, Y, Z (1.5 Hrs in total)	Note 1	Note 2
Mechanical Shock (non-operation)	Shock level : 50G, 11ms Waveform : Half sine wave Direction : ±X, ±Y, ±Z One time each direction	Note 1	Note 2
MTBF Demonstration	30,000 hours with confidence level 90%	Note 1	Note 3

Note1: Pass: Normal display image with no obvious non-uniformity and no line defect. Partial transformation of the module parts should be ignored.

Fail: No display image, obvious non-uniformity, or line defects.

Note2: Evaluation should be tested after storage at room temperature for two hours.

Note 3: The MTBF calculation is based on the assumption that the failure rate distribution meets the Exponential Model .

E. Safety

(1) Sharp Edge Requirements

There will be no sharp edges or corners on the display assembly that could cause injury.

(2) Materials

a. Toxicity

There will be no carcinogenic materials used anywhere in the display module. If toxic materials are used, they will be reviewed and approved by the responsible InnoLux Toxicologist.

b. Flammability

All components including electrical components that do not meet the flammability grade UL94-V1 in the module will complete the flammability rating exception approval process. The printed circuit board will be made from material rated 94-V1 or better. The actual UL flammability rating will be printed on the printed circuit board.

c. Capacitors

If any polarized capacitors are used in the display assembly, provisions will be made to keep them from being inserted backwards.

F. Display quality

The display quality of the color TFT-LCD module should be in compliance with the Innolux's Incoming inspection standard.

G. Handling precaution

The Handling of the TFT-LCD should be in compliance with the Innolux's handling principle standard.

H. Label

(1) Module Label

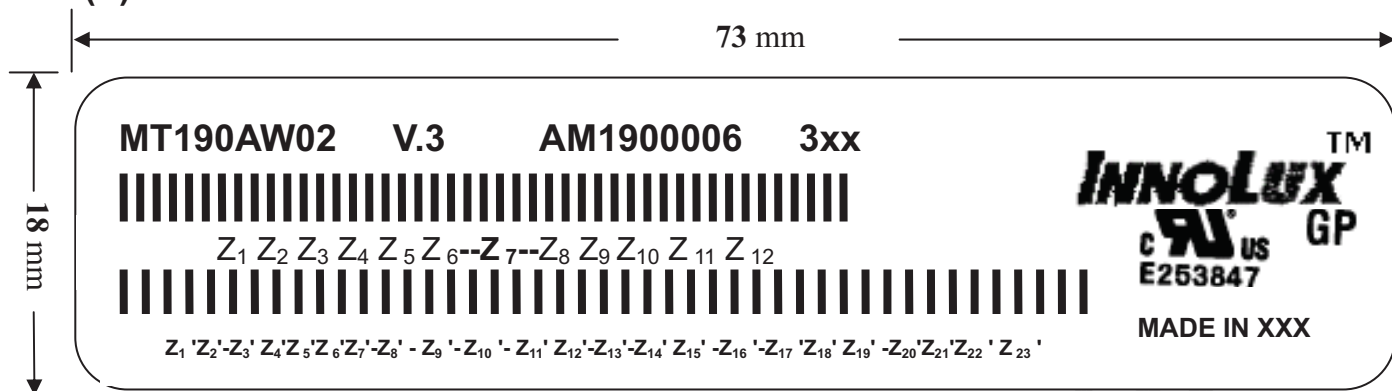

(a) Model Number: MT190AW02

(b) Version: V.3

(c) Serial ID I: Z₁ Z₂ Z₃ Z₄ Z₅ Z₆ Z₇ Z₈ Z₉ Z₁₀ Z₁₁ Z₁₂

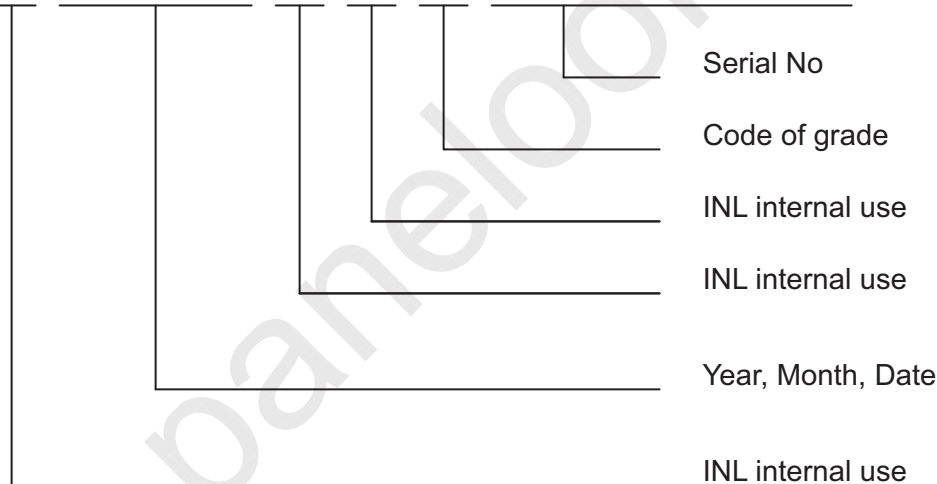

Serial ID includes the information as below:

1. Manufactured Date: Year: 0~9, for 2000~2009
2. Month: 1~9 & A~C for Jan.~Dec.
3. Date: 1~9 & A~Z (exclude I, O, Q, U) for 1st~31th
4. Code of grade: 1, 2, 3, 5, E
5. Serial No: Module manufacture sequence no

(d) Serial ID II (INL internal use)

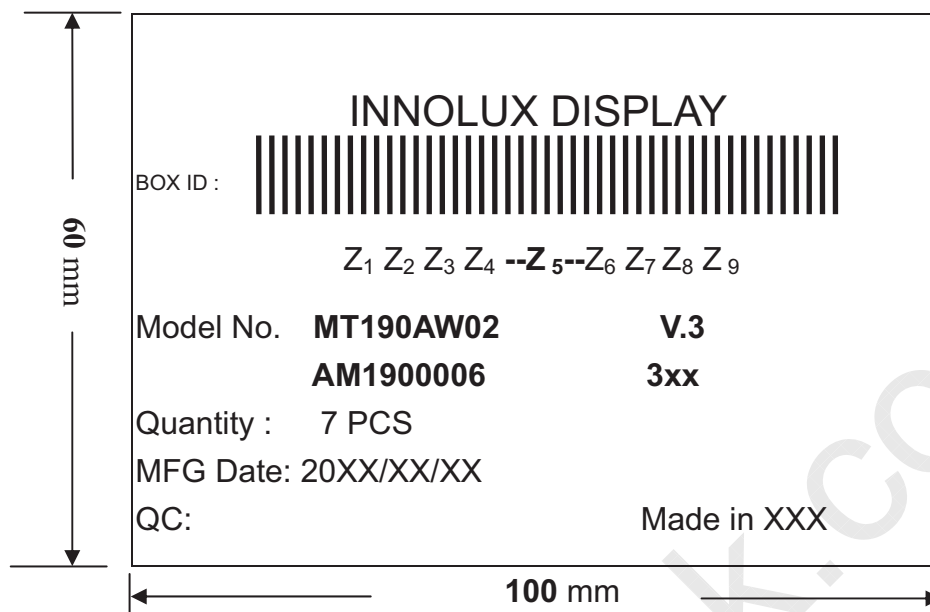
(2) Carton Label

(a) Model Number: MT190AW02

(b) Version: V.3

(c) Packing quantity: 7 pcs

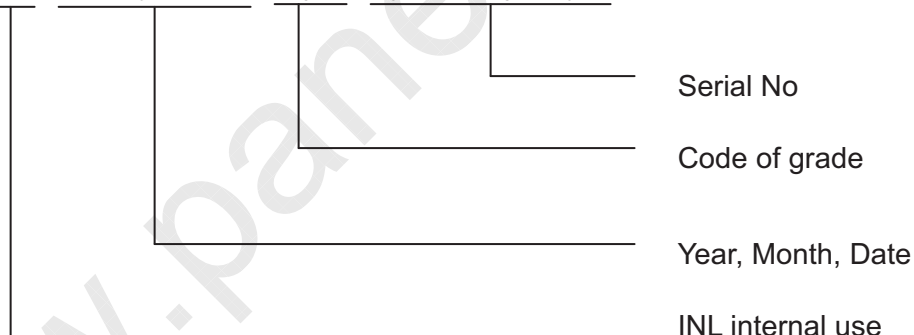
(d) Serial ID: Z₁ Z₂ Z₃ Z₄ Z₅ Z₆ Z₇ Z₈ Z₉

Serial ID includes the information as below:

(a) Manufactured Date: Year: 0~9, for 2000~2009

Month: 1~9 & A~C for Jan.~Dec.

Date: 1~9 & A~Z (exclude I, O, Q, U) for 1st~31th

(b) Code of grade: 1, 2, 3, 5, E

(c) Serial No: Module packing sequence no

I. Mechanical drawing

