

MT200LW02 V.0 LCD MODULE SPECIFICATION

- () Preliminary Specification
- (●) Final Specification

Customer	Approved by

www.jxlcd.com

Approved by	Checked by	Prepared by

Document Number: MT200LW02 V.0-DR4-26

MT200LW02 V.0 LCD MODULE SPECIFICATION

Department		Prepared by	Checked by
MKT			
PD	EE	www.jxlcd.com	
	ME		
TD			
RA			

Innolux Display Corporation

Document Number: MT200LW02 V.0-DR4-26

Contents:	
A. General Specification	5
B. Electrical Specifications	6
1. Pin assignment	6
2. Absolute maximum ratings	8
3. Electrical characteristics	9
a. Typical operating conditions	9
b. Display color vs. input data signals	13
c. Input signal timing	14
d. Display position	16
e. Backlight Unit	16
C. Optical specifications	17
D. Reliability test items	20
E. Safety	21
F. Display quality	21
G. Handling precaution	21
H. Label	22
I. Mechanical drawings	24
Appendix	

A. General specification

NO.	Item	Specification	Remark
1	Display resolution (pixel)	1600(H) x 900(V),HD+ resolution	
2	Active area (mm)	442.8(H)x 249.075(V)	
3	Screen size (inch)	20 inches diagonal	
4	Pixel pitch (mm)	0.2768 (H) x 0.2768 (V)	
5	Color configuration	R, G, B vertical stripe	
6	Overall dimension (mm)	462.8 (H)x272.0(W) x10.5 (D) (Typ)	
7	Weight (g)	1550(Max.)	
8	Surface treatment	Anti-Glare, Hard coating (3H)	Note 1
9	Input color signal	8 bit LVDS	
10	Display colors	16.7M (6 bit with Hi-FRC)	
11	Color saturation	70% NTSC	
11	Optimum viewing direction	6 o'clock	
12	Backlight	Side-light bar (White LED)	
13	Power consumption (W)	12.57	Typical
14	RoHS & Halogen free	RoHS & Halogen free compliance	
15	TC0'5.0	TC0'5.0 Compliance	

Note 1: Glare Option.

B. Electrical specifications

1.Pin assignment

1.1. TFT panel Connector

FOXCONN GS23302-0011R-7F or mechanical interface equivalent connector.

Pin No	Symbol	Description
Frame	VSS	Ground
1	RXinO0-	-LVDS differential data input, Chan 0-Odd
2	RXinO0+	+LVDS differential data input, Chan 0-Odd
3	RXinO1-	-LVDS differential data input, Chan 1-Odd
4	RXinO1+	+LVDS differential data input, Chan 1-Odd
5	RXinO2-	-LVDS differential data input, Chan 2-Odd
6	RXinO2+	+LVDS differential data input, Chan 2-Odd
7	VSS	Ground
8	RXOC-	-LVDS differential Clock input (Odd)
9	RXOC+	+LVDS differential Clock input (Odd)
10	RXinO3-	-LVDS differential data input, Chan 3-Odd
11	RXinO3+	+LVDS differential data input, Chan 3-Odd
12	RXinE0-	-LVDS differential data input, Chan 0-Even
13	RXinE0+	+LVDS differential data input, Chan 0-Even
14	VSS	Ground
15	RXinE1-	-LVDS differential data input, Chan 1-Even
16	RXinE1+	+LVDS differential data input, Chan 1-Even
17	VSS	Ground
18	RXinE2-	-LVDS differential data input, Chan 2-Even
19	RXinE2+	+LVDS differential data input, Chan 2-Even
20	RXEC-	-LVDS differential Clock input (Even)
21	RXEC+	+LVDS differential Clock input (Even)
22	RXinE3-	-LVDS differential data input, Chan 3-Even
23	RXinE3+	+LVDS differential data input, Chan 3-Even
24	VSS	Ground
25	NC	No Connection
26	NC	No Connection
27	NC	No Connection
28	VCC	+5.0V power supply
29	VCC	+5.0V power supply
30	VCC	+5.0V power supply
Frame	VSS	Ground

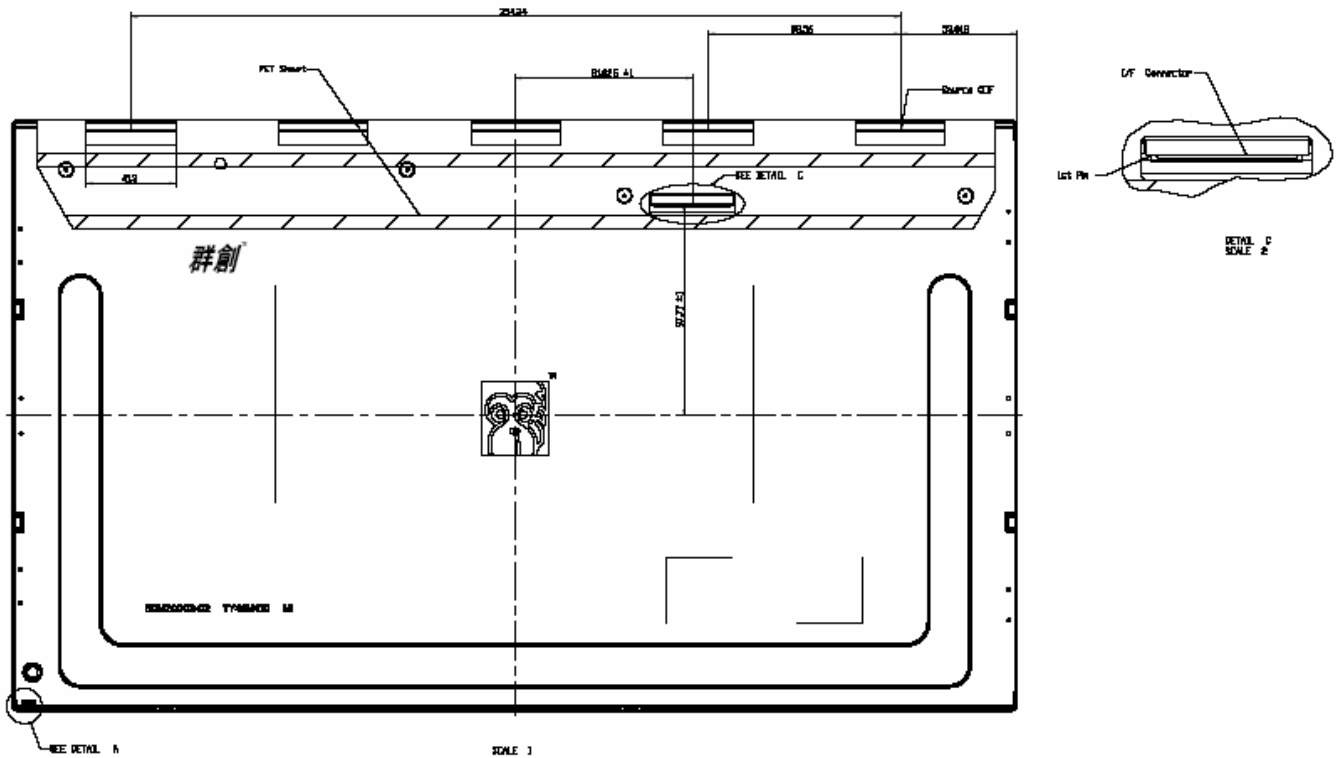

1.2. Recommend Connector for Backlight Unit

This connector is mounted on the monitor system board for LED light-bar FFC mating.

Connector Name/Designation	Match Connector
Manufacturer	Entery or FCN
Mating type part number	7083K-F10N-01L or FF04-404-103A

1.3. Light-bar Connector Pin Assignment

Light-bar Connector Pin Assignment:

Pin No	Symbol	Description
1	IRLED1	LED current sense for string 1
2	IRLED1	LED current sense for string 1
3	IRLED2	LED current sense for string 2
4	VLED	LED power supply
5	VLED	LED power supply
6	VLED	LED power supply
7	VLED	LED power supply
8	IRLED2	LED current sense for string 2
9	IRLED3	LED current sense for string 3
10	IRLED3	LED current sense for string 3

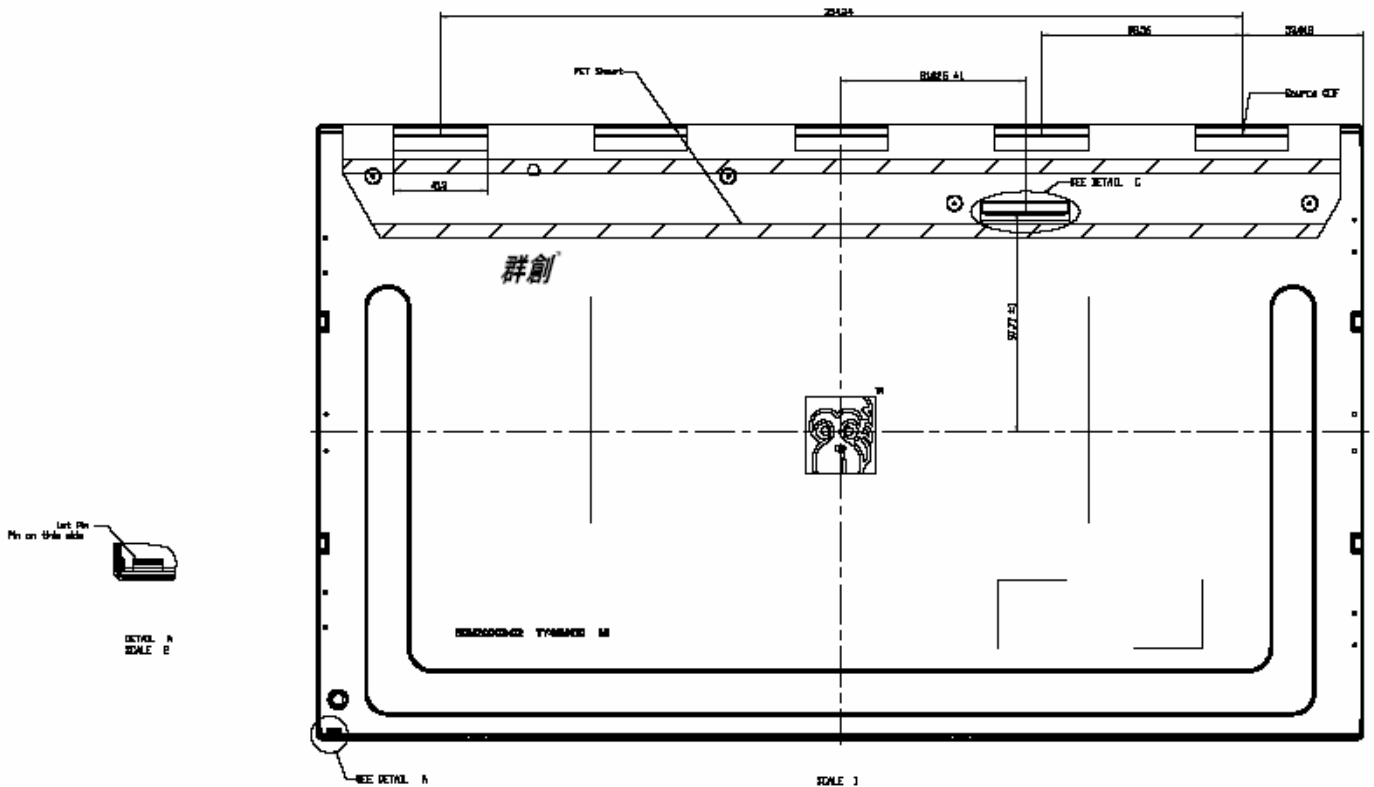

2. Absolute maximum ratings

Parameter	Symbol	Values			Unit	Remark
		Min.	Typ.	Max.		
Power voltage	Vcc	-0.3	-	6.0	V	At 25°C
Input signal voltage	VLH	-0.3	-	4.3	V	At 25°C
Operating temperature	Top	0	-	50	°C	Note 1
Storage temperature	TST	-20	-	60	°C	Note 2

Note 1: The relative humidity must not exceed 90% non-condensing at temperatures of 40°C or less. At temperatures greater than 40°C, the wet bulb temperature must not exceed 39°C.

Note 2: The unit should not be exposed to corrosive chemicals.

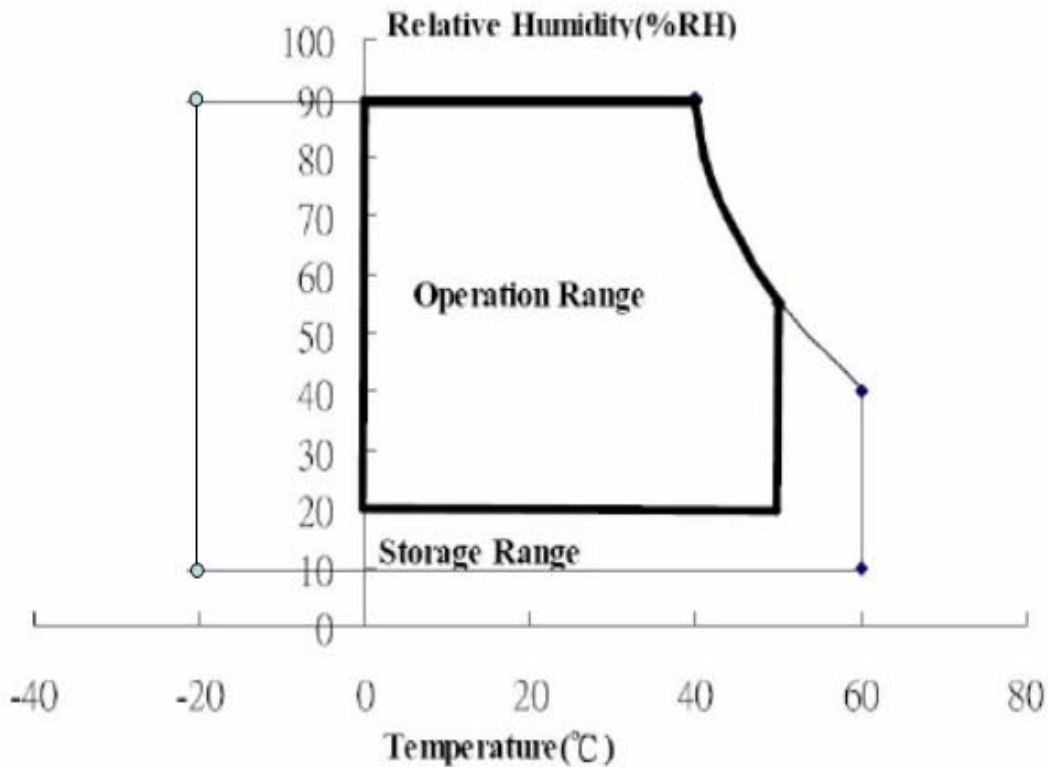

3. Electrical characteristics

a. Typical operating conditions

Item	Symbol	Min.	Typ.	Max.	Unit	Remark	
Input Voltage	V_{CC}	4.5	5	5.5	V		
Permissive Power Input Ripple	V_{RF}	-	-	0.15	V		
Input Current	Black	I_{CC}	-	800	mA	Note 1	
	White	I_{CC}	-	600		Note 2	
	Mosaic	I_{CC}	-	750		Note 3	
Rush Current	I_{Rush}	-	1.8	3	A	Note 4	
Logic Input	Common Mode Voltage	V_{CM}	-	1.2	V		
Voltage LVDS: IN+, IN-	Differential Input Voltage	ΔVID	200	-	600	mV	
	Threshold Voltage (High)	V_{TH}	-	-	100	mV	Note 5
	Threshold Voltage (Low)	V_{TL}	-100	-	-	mV	Note 5

Note 1 : The specified current is under the $V_{CC} = 5V$, $25^{\circ}C$, $f_v = 60Hz$ (frame frequency) condition whereas black pattern is displayed.

Note 2 : The specified current is under the $V_{CC} = 5V$, $25^{\circ}C$, $f_v = 60Hz$ (frame frequency) condition whereas white pattern is displayed.

Note 3 : The specified current is under the $V_{CC} = 5V$, $25^{\circ}C$, $f_v = 60Hz$ (frame frequency) condition whereas mosaic pattern (black & white [8*6]) is displayed.

White : 255 Gray

Black : 0 Gray

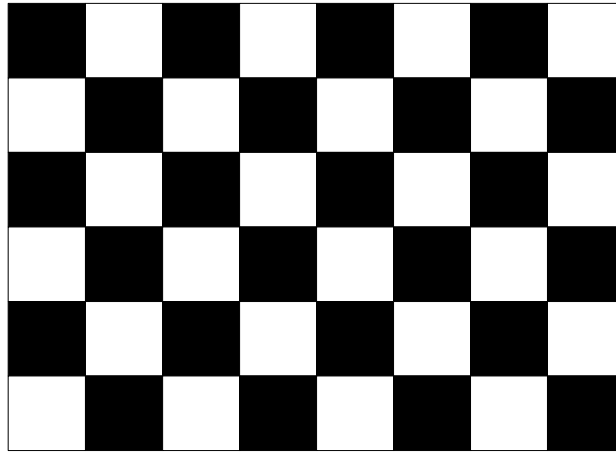

Note 4 : test condition :

(1) $V_{DD} = 5\text{ V}$, V_{DD} rising time = $470\ \mu\text{s} \pm 10\%$

(2) Pattern: Mosaic pattern

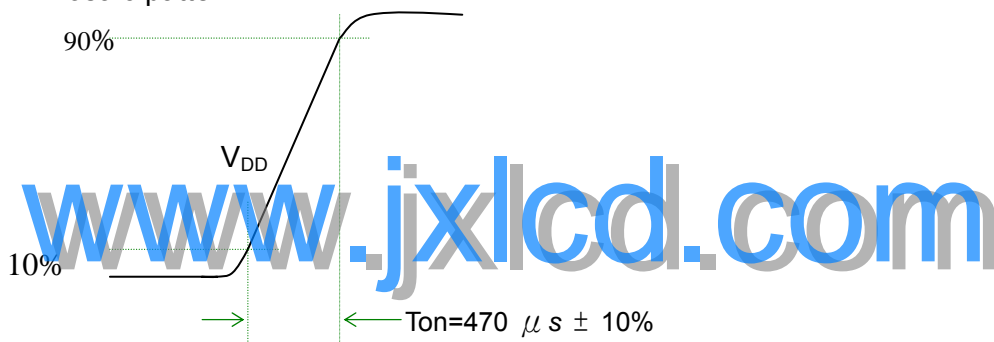

(3) Test circuit

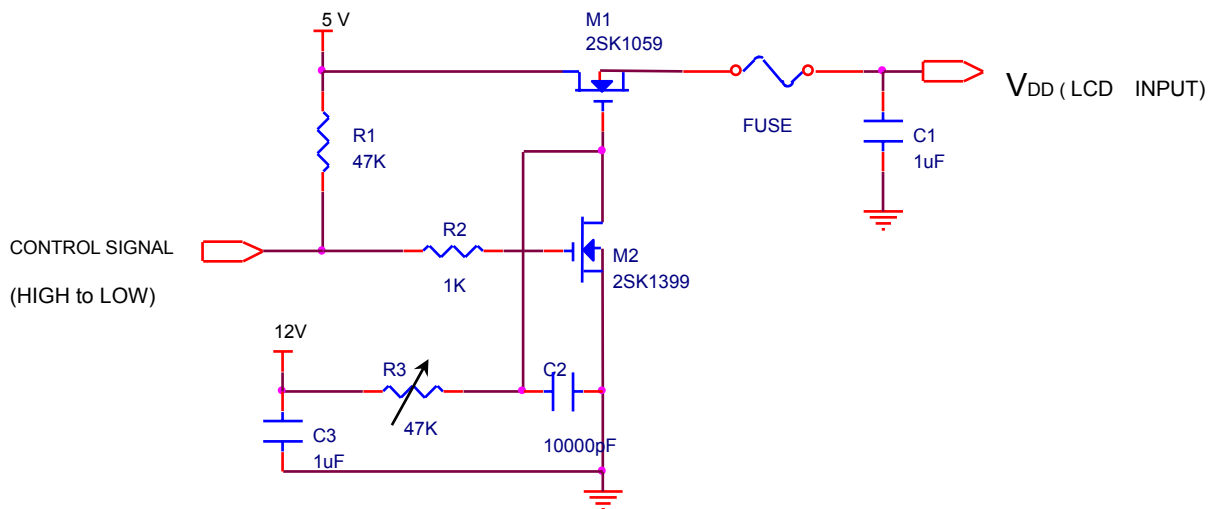

Note 5: LVDS signal definition

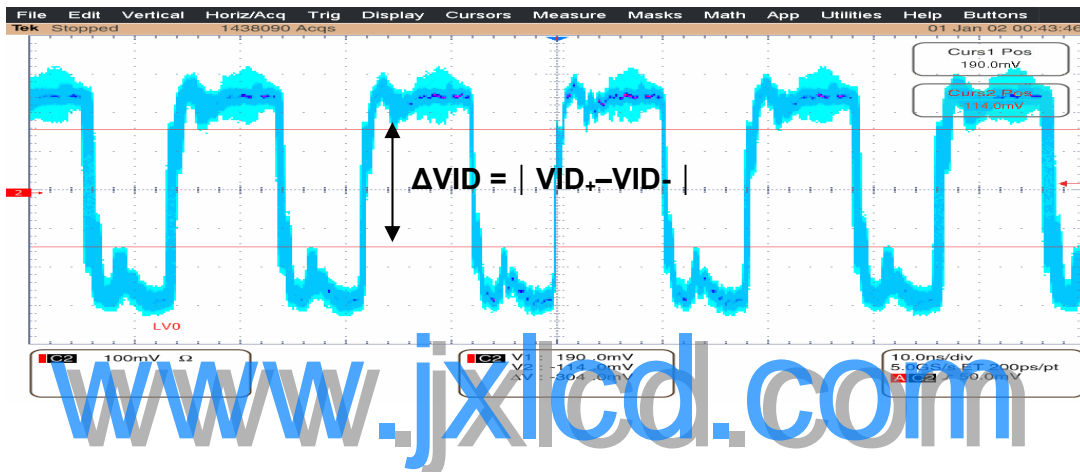
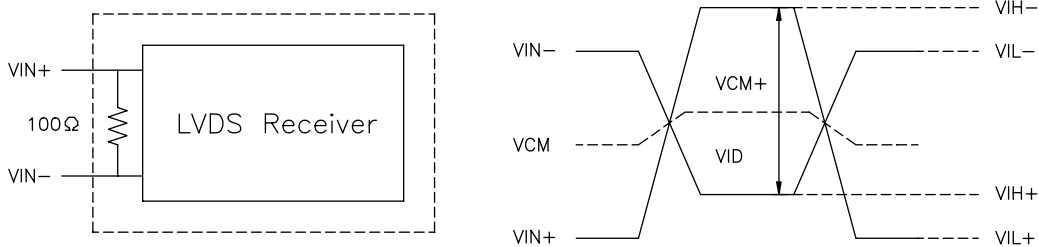

VIN₊ = Positive differential DATA & CLK Input
 VIN₋ = Negative differential DATA & CLK Input

$$\Delta V_{CM} = |V_{CM+} - V_{CM-}|,$$

$$\Delta V_{ID} = |V_{ID+} - V_{ID-}|,$$

$$V_{ID+} = |V_{IH+} - V_{IH-}|,$$

$$V_{ID-} = |V_{IL+} - V_{IL-}|,$$

$$V_{CM} = (V_{IN+} + V_{IN-})/2,$$

$$V_{CM+} = (V_{IH+} + V_{IH-})/2,$$

$$V_{CM-} = (V_{IL+} + V_{IL-})/2,$$

Note 6 : Power on sequence for LCD V_{DD}

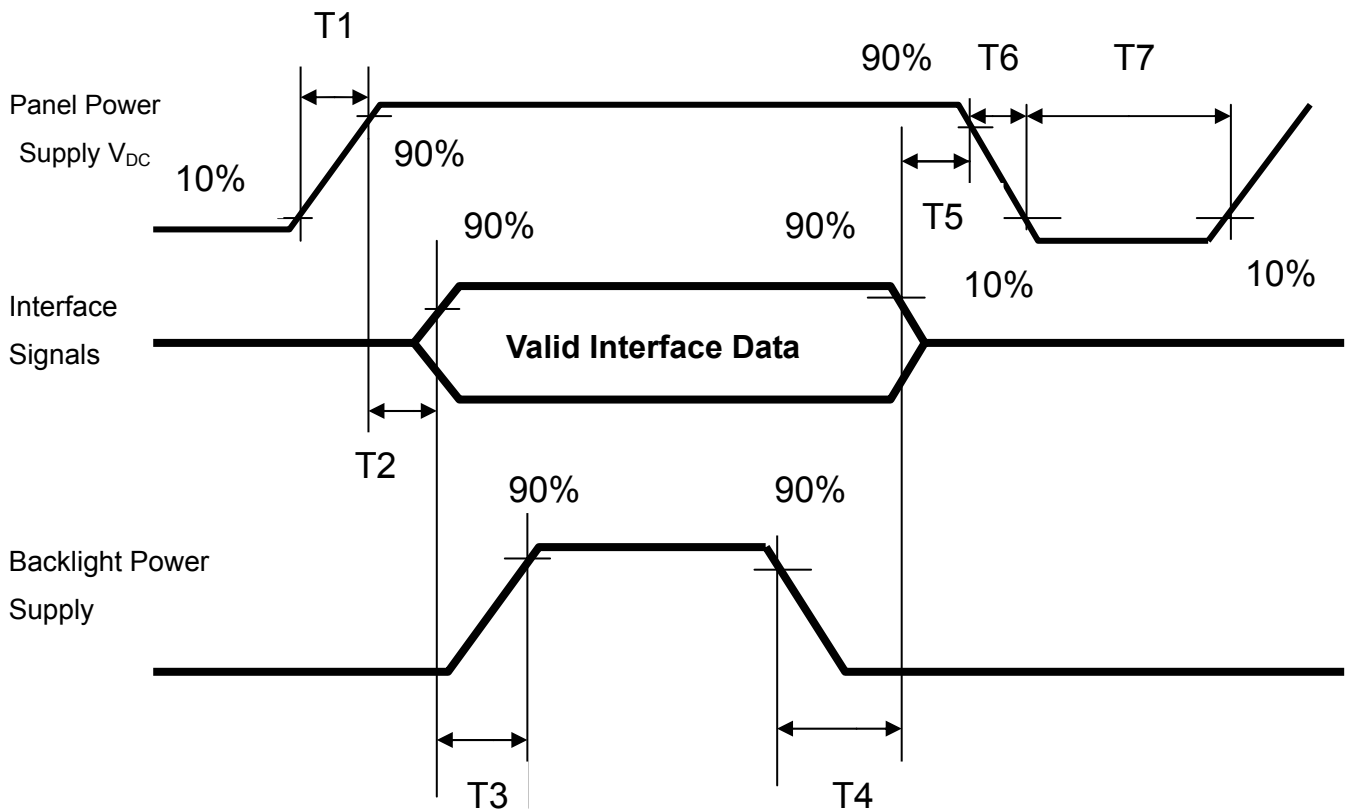

www.jxlcd.com

Parameter	Value			Unit
	Min	Typ	Max	
T1	0.1	-	10	ms
T2	0	30	50	ms
T3	200	250	-	ms
T4	100	250	-	ms
T5	0	20	50	ms
T6	0.1	-	50	ms
T7	1000	-	-	ms

b. Display color vs. input data signals

The brightness of each primary color (red, green and blue) is based on the 8-bit gray scale data input for the color; the higher the binary input, the brighter the color. The table below provides a reference for color versus data input.

Color	Input color data																							
	Red								Green								Blue							
	MSB				LSB				MSB				LSB				MSB				LSB			
	R7	R6	R5	R4	R3	R2	R1	R0	G7	G6	G5	G4	G3	G2	G1	G0	B7	B6	B5	B4	B3	B2	B1	B0
Basic colors	Black	0	0	0	0	0	0	0	0	0	0	0	0	0	0	0	0	0	0	0	0	0	0	0
	Red(255)	1	1	1	1	1	1	1	1	0	0	0	0	0	0	0	0	0	0	0	0	0	0	0
	Green(255)	0	0	0	0	0	0	0	0	1	1	1	1	1	1	1	1	0	0	0	0	0	0	0
	Blue(255)	0	0	0	0	0	0	0	0	0	0	0	0	0	0	0	0	1	1	1	1	1	1	1
	Cyan	0	0	0	0	0	0	0	0	1	1	1	1	1	1	1	1	1	1	1	1	1	1	1
	Magenta	1	1	1	1	1	1	1	1	0	0	0	0	0	0	0	0	1	1	1	1	1	1	1
	Yellow	1	1	1	1	1	1	1	1	1	1	1	1	1	1	1	1	0	0	0	0	0	0	0
	White	1	1	1	1	1	1	1	1	1	1	1	1	1	1	1	1	1	1	1	1	1	1	1
Red	Red(000) dark	0	0	0	0	0	0	0	0	0	0	0	0	0	0	0	0	0	0	0	0	0	0	
	Red(001)	0	0	0	0	0	0	1	0	0	0	0	0	0	0	0	0	0	0	0	0	0	0	
	Red(002)	0	0	0	0	0	1	0	0	0	0	0	0	0	0	0	0	0	0	0	0	0	0	
	:	:	:	:	:	:	:	:	:	:	:	:	:	:	:	:	:	:	:	:	:	:	:	
	Red(253)	1	1	1	1	1	1	0	1	0	0	0	0	0	0	0	0	0	0	0	0	0	0	
	Red(254)	1	1	1	1	1	1	1	0	0	0	0	0	0	0	0	0	0	0	0	0	0	0	
	Red(255) bright	1	1	1	1	1	1	1	1	0	0	0	0	0	0	0	0	0	0	0	0	0	0	
Green	Green(000) dark	0	0	0	0	0	0	0	0	0	0	0	0	0	0	0	0	0	0	0	0	0	0	
	Green(001)	0	0	0	0	0	0	0	0	0	0	0	0	0	0	1	0	0	0	0	0	0	0	
	Green(002)	0	0	0	0	0	0	0	0	0	0	0	0	0	1	0	0	0	0	0	0	0	0	
	:	:	:	:	:	:	:	:	:	:	:	:	:	:	:	:	:	:	:	:	:	:	:	
	Green(253)	0	0	0	0	0	0	0	1	1	1	1	1	1	0	1	0	0	0	0	0	0	0	
	Green(254)	0	0	0	0	0	0	0	1	1	1	1	1	1	1	0	0	0	0	0	0	0	0	
	Green(255) bright	0	0	0	0	0	0	0	1	1	1	1	1	1	1	1	0	0	0	0	0	0	0	
Blue	Blue(000) dark	0	0	0	0	0	0	0	0	0	0	0	0	0	0	0	0	0	0	0	0	0	0	
	Blue(001)	0	0	0	0	0	0	0	0	0	0	0	0	0	0	0	0	0	0	0	0	0	1	
	Blue(002)	0	0	0	0	0	0	0	0	0	0	0	0	0	0	0	0	0	0	0	0	1	0	
	:	:	:	:	:	:	:	:	:	:	:	:	:	:	:	:	:	:	:	:	:	:	:	
	Blue(253)	0	0	0	0	0	0	0	0	0	0	0	0	0	0	0	1	1	1	1	1	1	0	
	Blue(254)	0	0	0	0	0	0	0	0	0	0	0	0	0	0	0	1	1	1	1	1	1	0	
	Blue(255) bright	0	0	0	0	0	0	0	0	0	0	0	0	0	0	0	1	1	1	1	1	1	1	

c. Input signal timing

Support Input Timing Table

	Item	Description	Min.	Typ.	Max.	Unit	Remark
Clock	Dclk	period	13.1	16.8	20.6	nS	
		frequency	48.5	59.5	76.1	MHz	
Spread Spectrum	T_{RCL}	Input Cycle to Cycle Jitter	$-0.02 \cdot T_C$	---	$0.02 \cdot T_C$	ns	Note 1
	T_{LVCCS}	Channel to Channel Skew	$-0.02 \cdot T_C$	---	$0.02 \cdot T_C$	ns	Note 2
	F_{SSMR}	Spread Spectrum Modulation Range	$0.97 \cdot F_C$	---	$1.03 \cdot F_C$	MHz	Note 3
	F_{SSMF}	Spread Spectrum Modulation Frequency	---	---	100	KHz	
Vertical	T_{V_TOTAL}	V total line number	905	926	942	T_{H_TOTAL}	Note 4
	T_{V_DATA}	Data duration	—	900	—	T_{H_TOTAL}	
	T_{VB}	V-blank	5	26	42	T_{H_TOTAL}	
	f_V	frequency	50	60	75	Hz	
Horizontal	T_{H_TOTAL}	H total pixel number	950	1056	1150	Dclk	
	T_{H_DATA}	Data duration	—	800	—	Dclk	
	T_{HB}	H-blank	150	256	350	Dclk	

Note 1: The input Cycle to Cycle Jitter is defined as below figures. $T_{RCL} = |T_1 - T|$

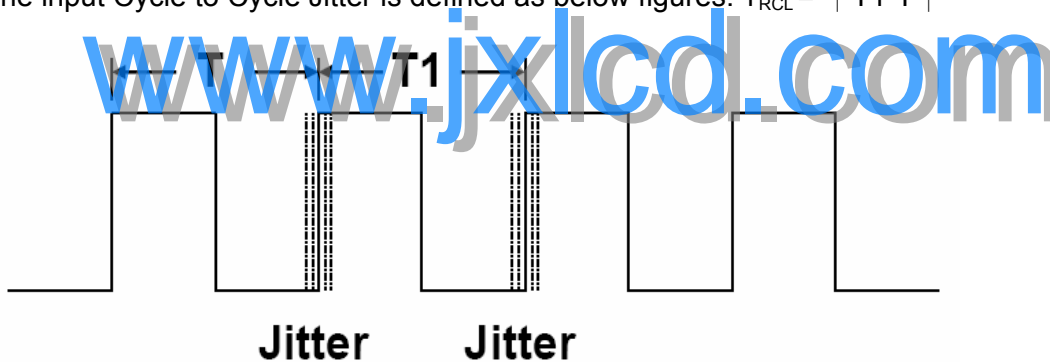

Note 2: The input Channel to Channel skew is defined as below figures.

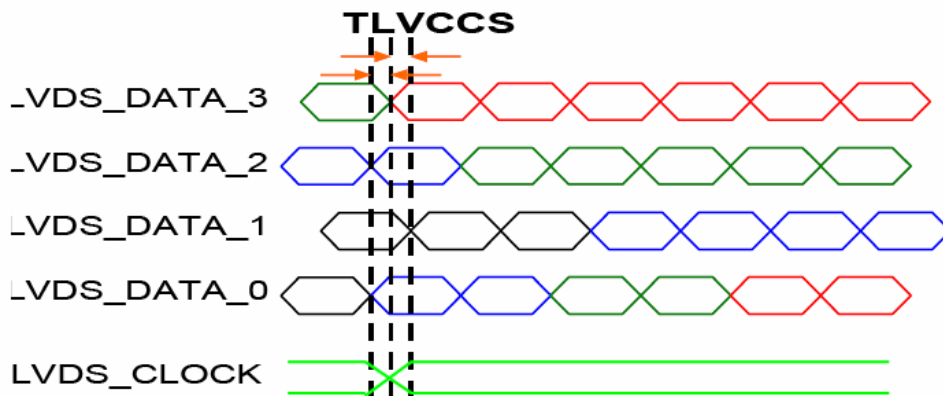

Note 3: The spread spectrum modulation range and frequency is defined as below figures.

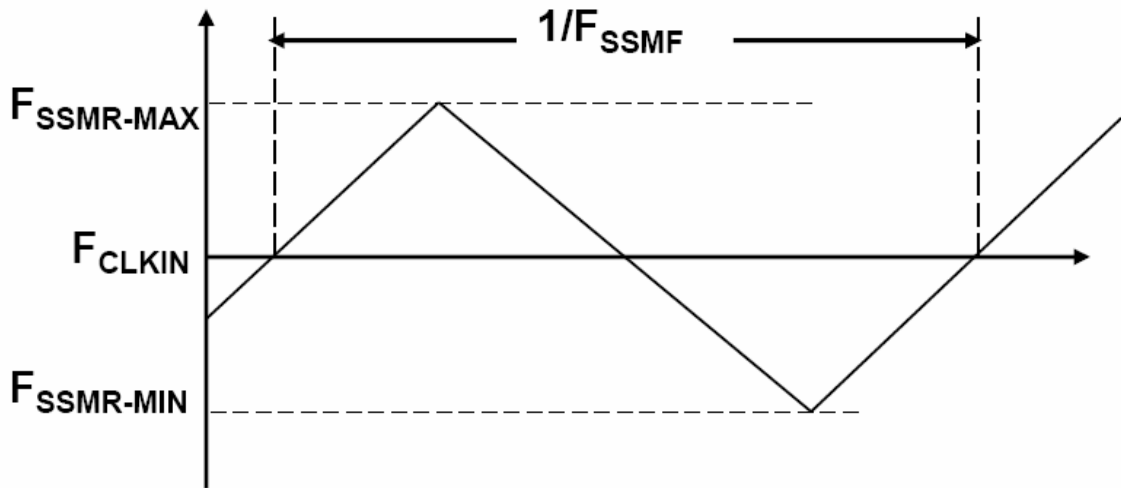

Note 4: Because this module is operated by DE only mode, Hsync and Vsync input signals should be set to low Logic level or ground. Otherwise, this module would operate abnormally.

INPUT SIGNAL TIMING DIAGRAM

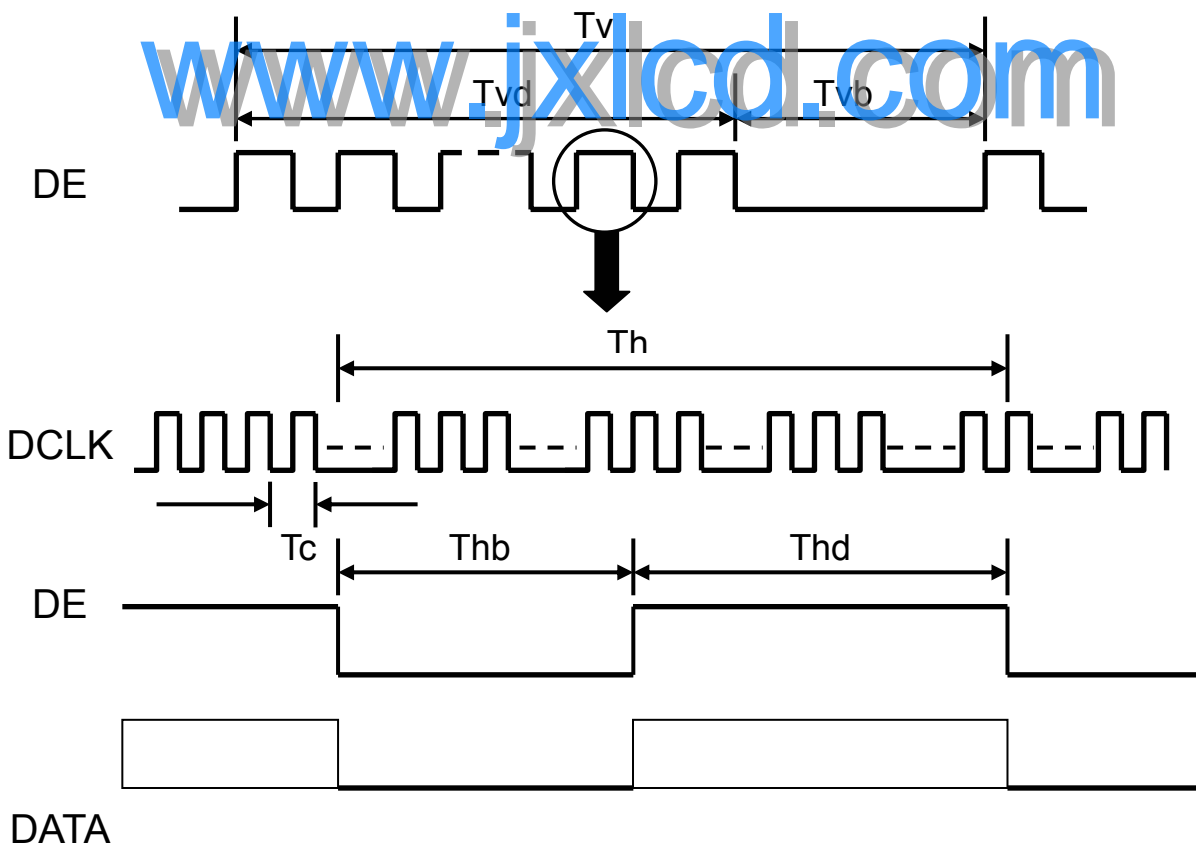

d. Display Position

D(1, 1)	D(2, 1)	D(720, 1)	D(1599, 1)	D(1600, 1)
D(1, 2)	D(2, 2)	D(720, 2)	D(1599, 2)	D(1600, 2)
⋮		⋮	⋮	⋮
D(1, 450)	D(2, 450)	D(720, 450)	D(1599, 450)	D(1600, 450)
⋮		⋮	⋮	⋮
D(1, 899)	D(2, 899)	D(720, 899)	D(1599, 899)	D(1600, 899)
D(1, 900)	D(2, 900)	D(720, 900)	D(1599, 900)	D(1600, 900)

e. Backlight driving conditions

Parameter	Symbol	Value			Unit	Note
		Min.	Typ.	Max.		
Light Bar Input Voltage	VLED	---	38.1	41.7	VDC	(Duty 100%)
Light Bar Input Current	ILED	---	225	247.5	mADC	(1),(2),(3)
Power Consumption	PLED	---	8.57	10.3	W	(4)
LED Life Time	LBL	30000	----	----	Hrs	(5)

Note (1): There is one Light Bar, and the specified current is input LED chip 100% duty current.

Note (2): The sensing current of each string is 75mA.

Note (3): The light bar have three current sensing strings, so that the light bar input current is 225mA.

Note (4): $PLED = ILED \times VLED$.

Note (5): The life time is determined as the time at which luminance of the LED becomes 50% of the initial brightness or not normal lighting at ILED=225mA on condition of continuous operating at 25±2°C.

C. Optical specifications

Item	Symbol	Condition	Specification			Unit	Remark
			Min.	Typ.	Max.		
Response time	Tr	$\theta = 0^\circ$	-	1.5	4	ms	Note 4
	Tf		-	3.5	6		
	Tr+Tf		-	5	10		
Contrast ratio	CR	$\theta = 0^\circ$	700	1000	-		Note 3,5
Viewing angle	Top	$CR \geq 10$	70	80	-	deg.	Note 3,5,6
	Bottom	$CR \geq 10$	70	80	-		
	Left	$CR \geq 10$	75	85	-		
	Right	$CR \geq 10$	75	85	-		
Brightness (Center)	YL		200	250		nit	Note 3
Color chromaticity(CIE)	Wx	$\theta = 0^\circ$	-0.03	0.3130	+0.03		Note 3
	Wy			0.3290			
	Rx			0.636			
	Ry			0.351			
	Gx			0.326			
	Gy			0.623			
	Bx			0.149			
	By			0.059			
White uniformity (9)	δW		0.70	0.75	-		Note 3,7
Cross talk	Ct		-	-	2%		Note8

Note 1: Ambient temperature = 25°C.

Note 2: To be measured in dark room after backlight warm up 10 minutes.

Note 3: To be measured with a viewing cone of 2° by Topcon luminance meter BM-5A.

Note 4: Definition of response time:

The output signals of BM-7 are measured when the input signals are changed from “Black” to “White” (falling time) and from “White” to “Black” (rising time), respectively. The response time interval is between the 10% and 90% of amplitudes. Refer to figure as below.

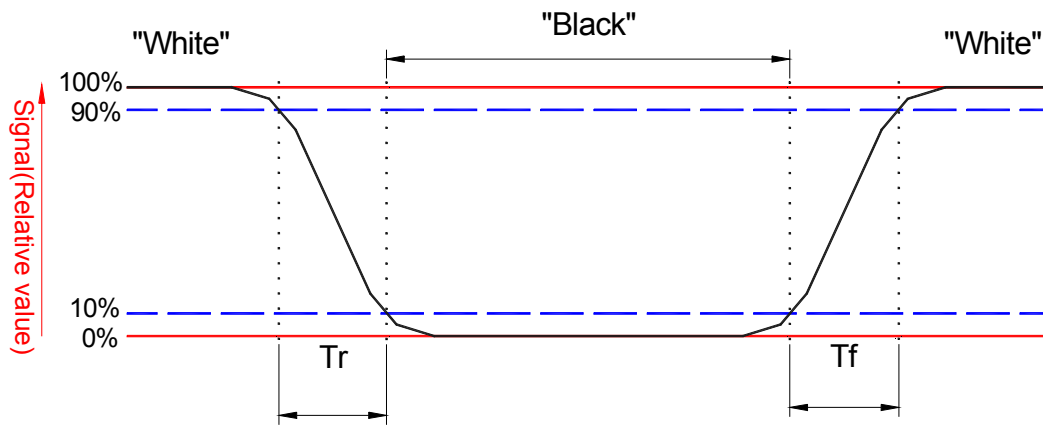

Note 5: Definition of contrast ratio:

Contrast ratio is calculated by the following formula.

$$\text{Contrast ratio (CR)} = \frac{\text{Brightness on the "white" state}}{\text{Brightness on the "black" state}}$$

Note 6: Definition of viewing angle

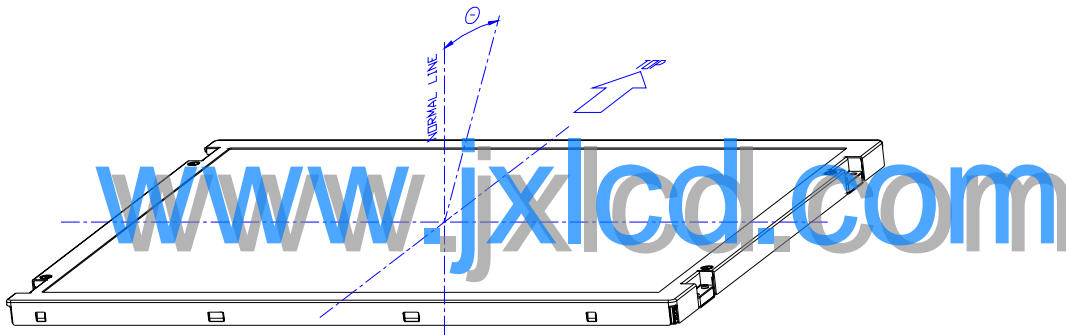

Note 7: Definition white uniformity:

Luminance are measured at the following nine points (P1~P9).

$$\delta_w = \frac{\text{Minimum Brightness of nine points (P1~P9).}}{\text{Maximum Brightness of nine points (P1~P9).}}$$

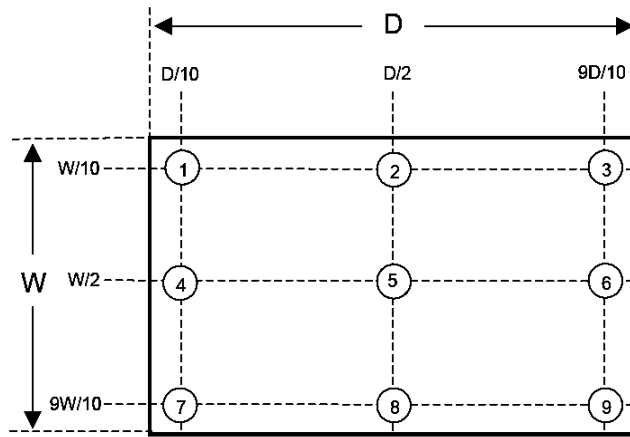

Note 8:

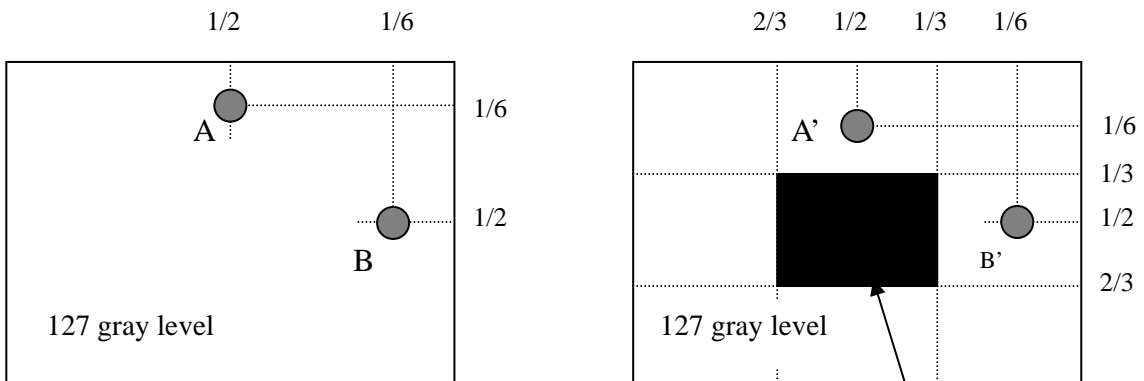

www.jxlcd.com

$|L_A - L_{A'}| / L_A \times 100\% = 2\% \text{ max.}$, L_A and $L_{A'}$ are brightness at location A and A'
 $|L_B - L_{B'}| / L_B \times 100\% = 2\% \text{ max.}$, L_B and $L_{B'}$ are brightness at location B and B'

Note 10: Optical characteristic measurement setup.

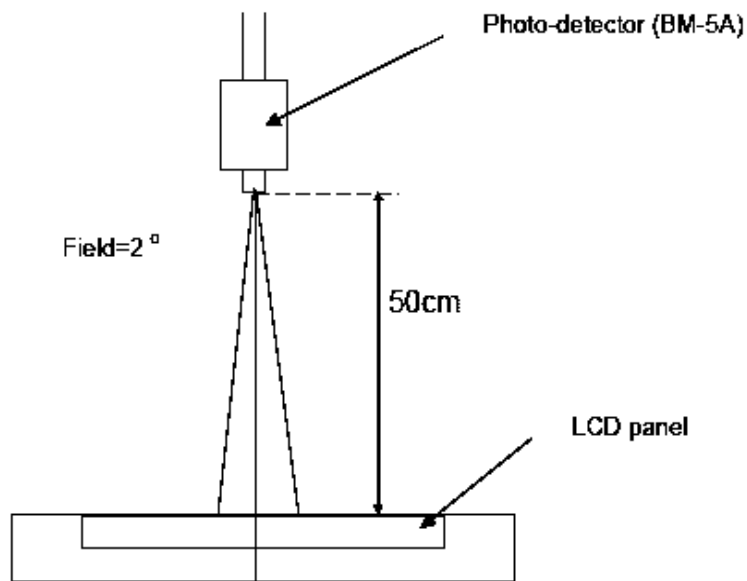

D. Reliability test items

Test Item	Test Condition	Judgment	Remark
High temperature & high humidity operation	40°C, 90%RH, 240Hrs (No condensation)	Note 1	Note 2
High temperature operation	50°C, 240Hrs	Note 1	Note 2
Low temperature operation	0°C, 240Hrs	Note 1	Note 2
Thermal Shock (non-operation)	-20°C~60°C 1Hr, 1Hr, 100cycles	Note 1	Note 2
Electrostatic discharge (ESD)	Contact: +/-8kV, 150pF(330ohms), 16 points, 10 times/1 point, 1 time/1 sec Air discharge: +/-15kV, 150pF(330ohms), 9points, 10 times/1 point, 1 time/1 sec	Note 1	Note 2
Vibration (non-operation)	Vibration level : 1.5G Bandwidth : 10-300Hz Waveform : sine wave, sweep rate : 10min 30 min for each direction X, Y, Z (1.5 Hrs in total)	Note 1	Note 2
Mechanical Shock (non-operation)	Shock level : 50G, 11ms Waveform : Half sine wave Direction : ±X, ±Y, ±Z One time each direction	Note 1	Note 2
MTBF Demonstration	30,000 hours with confidence level 90%	Note 1	Note 3

Note1: Pass: Normal display image with no obvious non-uniformity and no line defect.

Partial transformation of the module parts should be ignored.

Fail: No display image, obvious non-uniformity, or line defects.

Note2: Evaluation should be tested after storage at room temperature for one hour.

Note 3: The MTBF calculation is based on the assumption that the failure rate distribution meets the Exponential Model.

E. Safety

(1) Sharp Edge Requirements

There will be no sharp edges or corners on the display assembly that could cause injury.

(2) Materials

a. Toxicity

There will be no carcinogenic materials used anywhere in the display module. If toxic materials are used, they will be reviewed and approved by the responsible InnoLux Toxicologist.

b. Flammability

All components including electrical components that do not meet the flammability grade UL94-V1 in the module will complete the flammability rating exception approval process. The printed circuit board will be made from material rated 94-V1 or better.

c. Capacitors

If any polarized capacitors are used in the display assembly, provisions will be made to keep them from being inserted backwards.

F. Display quality

The display quality of the color TFT-LCD module should be in compliance with the Innolux's Incoming inspection standard.

G. Handling precaution

The Handling of the TFT-LCD should be in compliance with the Innolux's handling principle standard.

www.jxlcd.com

H. Label

(1) Module Label

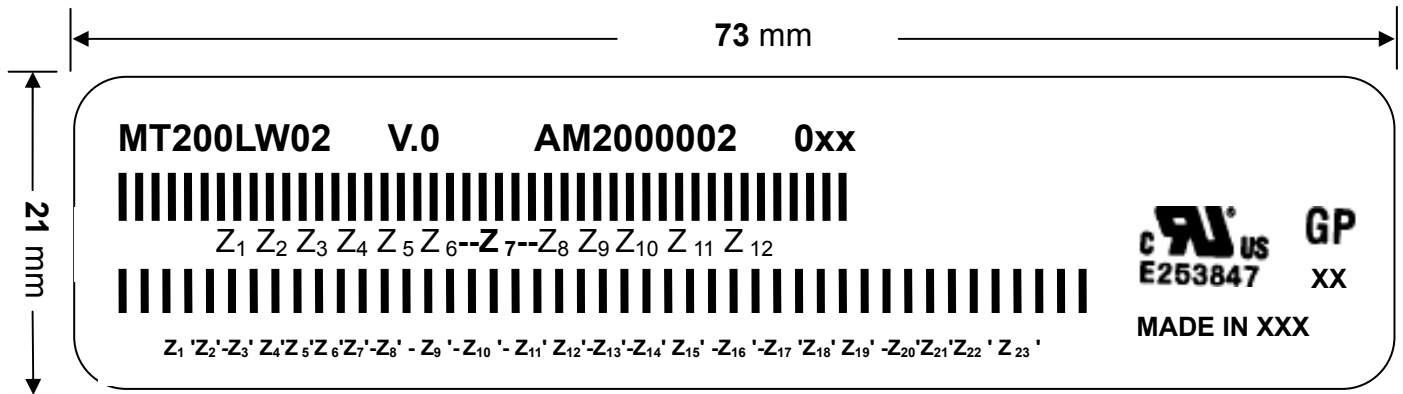

(a) Model Number: MT200LW02

(b) Version: V.0

(c) Serial ID I: Z₁ Z₂ Z₃ Z₄ Z₅ Z₆ Z₇ Z₈ Z₉ Z₁₀ Z₁₁ Z₁₂

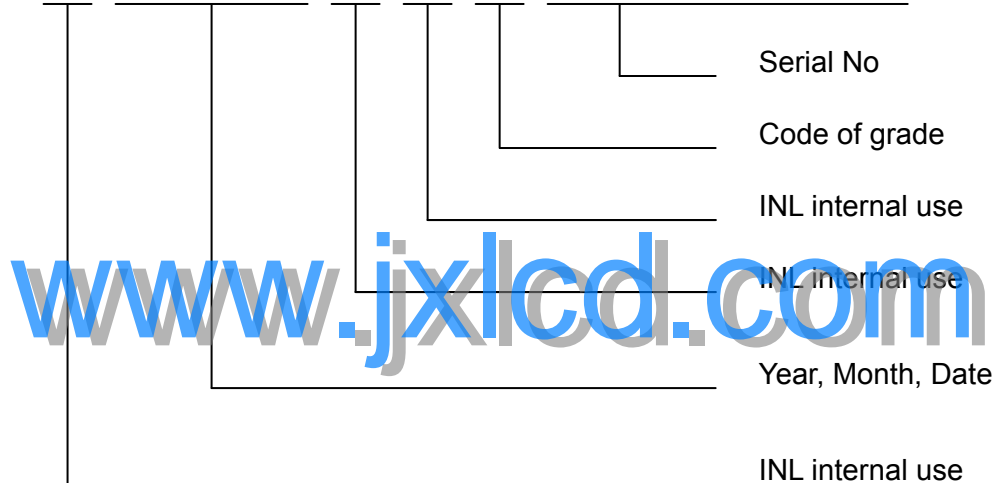

Serial ID includes the information as below:

1. Manufactured Date: Year: 0~9, for 2000~2009
2. Month: 1~9 & A~C for Jan.~Dec.
3. Date: 1~9 & A~Z (exclude I, O, Q, U) for 1st~31th
4. Code of grade: 1, 2, 3, 5, E
5. Serial No: Module manufacture sequence no

(d) Factory ID: E: 01; H: 00

(e) Serial ID II (INL internal use)

(2) Carton Label

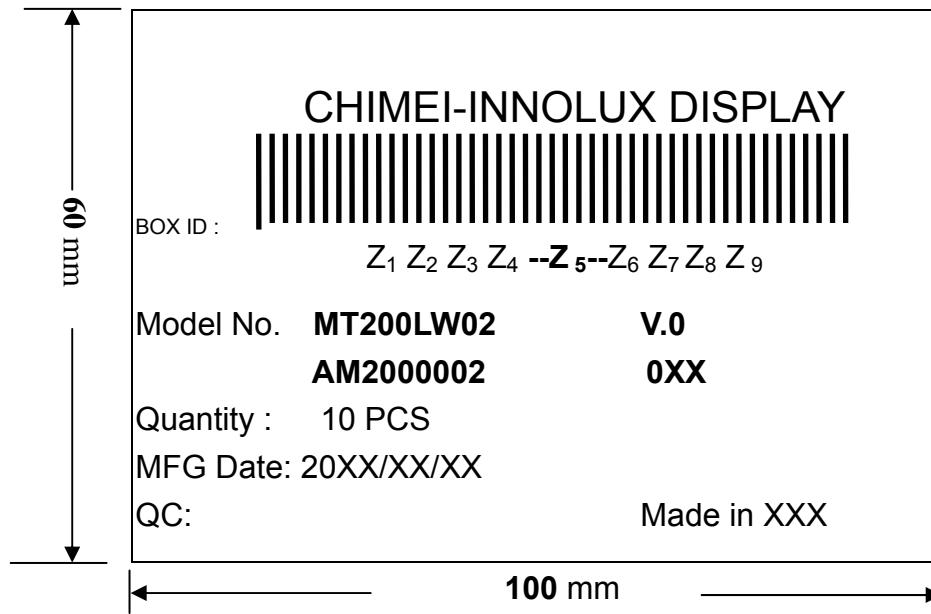

- (a) Model Number: MT200LW02
- (b) Version: V.0
- (c) Packing quantity: 10 pcs
- (d) Serial ID: Z₁ Z₂ Z₃ Z₄ Z₅ Z₆ Z₇ Z₈ Z₉

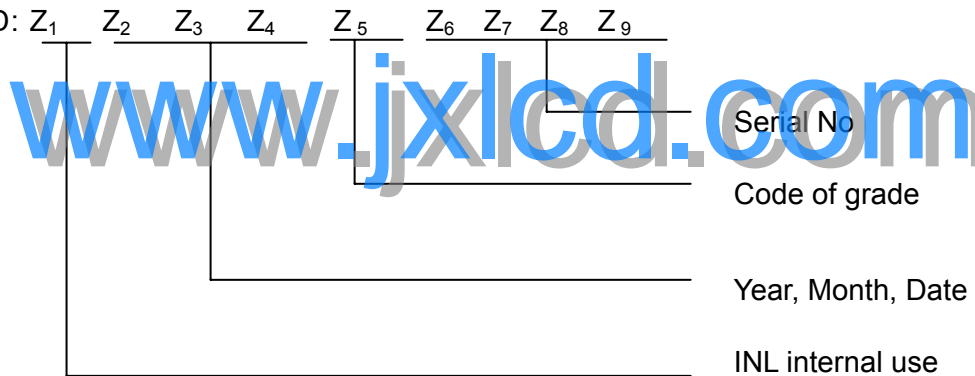

Serial ID includes the information as below:

- (a) Manufactured Date: Year: 0~9, for 2010~2019
 Month: 1~9 & A~C for Jan.~Dec.
 Date: 1~9 & A~Z (exclude I, O, Q, U) for 1st~31th
- (b) Code of grade: 1, 2, 3, 5, E
- (c) Serial No: Module packing sequence no

H. Mechanical drawing



SCALE 1

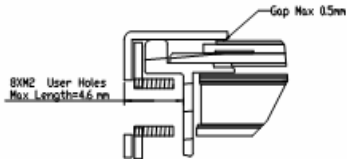

SECTION A-A
 SCALE 5

- NOTES:
1. Backlight has 1 LED PKG ASS'Y
 2. I/F Connector Spec: FDACDN, GS23302-001R-7F
 3. Side Mount Holes Rotational Torque Max 8kgf-cm (10times)
 4. Unspecified Tolerance to be ±0.5mm

REV	DATE	BY	CHK	APP	FILE NAME
1					MT200LW02_V0

